



647502 EN (19/12/2022)

ME 315 48V S3

ME 316 48V S3

ME 318 48V S3

ME 320 48V S3

ME 315 48V S3 FOB

ME 316 48V S3 FOB

ME 318 48V S3 FOB

ME 320 48V S3 FOB

OPERATOR'S MANUAL

(ORIGINAL MANUAL)

IMPORTANT

Carefully read and understand this instruction manual before using this machine.

It contains all information relating to operation, handling and equipment, as well as important recommendations to be followed.

This document also contains precautions for use, as well as information on the service and routine maintenance required to ensure the machine's continued reliability and safety of use.

WHENEVER YOU SEE THIS SYMBOL, IT MEANS:



PLEASE NOTE! BE CAREFUL! YOUR SAFETY, THAT OF OTHERS, OR THE SAFETY OF THE MACHINE IS AT RISK.

- This manual has been produced based on the equipment list and technical characteristics given at the time of its design.
- The machine's equipment level depends on the options chosen and the country of sale.
- Depending on the machine's options and the date of sale, certain equipment or functions described in this manual may not be present on this machine.
- Descriptions and figures are non-binding.
- MANITOU reserves the right to change its models and their equipment without being required to update this manual.
- The MANITOU network, consisting exclusively of qualified professionals, is available to answer all your questions.
- This manual is an integral part of the machine.
- It is to be kept in its storage location at all times for ease of reference.
- Give this manual to the new owner if the machine is resold.

1st EDITION

A-01/09/2016

UPDATED

10/05/2017 2-10 ; 2-12 ; 2-18 ; 2-28 ; 3-6
10/05/2021 2-18 ; 2-22 – 2-24
19/12/2022 0-1 – 0-5
2-3 – 2-30
3-6 ; 3-22
4-6

The brochure and all its contents, including diagrams, are the proprietary and confidential intellectual property of Manitou BF and / or its subsidiaries ("Manitou Group"). Any reproduction, publication or dissemination of any part of the brochure without the express written authorization of Manitou Group is strictly prohibited. Any violation of this provision will subject the offending party to prosecution by Manitou Group to the fullest extent of the law. The logos and the company's visual identity are the property of Manitou Group and may not be used without the express written authorization of Manitou Group.

All trademarks, registered and unregistered, is and shall remain the property of Manitou BF or its respective owner.

Any reproduction, source code access, decompilation, modification, copy (other than backup copies), correction of errors, transmission or distribution of any software built into Manitou Group machines is strictly prohibited.

In the event that the measures above nevertheless prove essential to enable use of the software, in accordance with its destination, or to obtain the information required for interoperability with other software created independently, the user should contact Manitou Group in advance and Manitou may, at its sole discretion, take the necessary measures or give access to only the information strictly necessary for interoperability.

Any breach of these requirements is likely to constitute a counterfeiting offense subject to legal action by Manitou Group.

Connected Manitou Group machines are equipped with boxes that collect technical data on the machines (such as geo-tracking data or data on component operation). This data, which is organized, processed and enhanced by algorithms and expertise proprietary to Manitou Group, constitutes, in combination with other elements, independent or not, a protected database according to laws & regulations on IP purposes.

It is strictly forbidden to have access to all or part of this database and to use the data (including in the event of accidental access) without explicit prior authorization from Manitou Group. In the event that Manitou Group authorizes a Manitou Group machine user to access all or part of this database, Manitou Group, as producer of this database, cedes to the user only a right to personal, non-exclusive, non transferable use of the database, and only by access to an information technology platform hosted by a server owned or controlled by Manitou Group.

In any case, the following are strictly prohibited:

- any extraction, reproduction, representation, reuse through provision to the public, distribution, transfer, permanent or temporary, on any medium, by any means, and in any form whatsoever, of all or of a qualitatively or quantitatively substantial part of the contents of this database,*
- any extraction, reproduction, representation, reuse through provision to the public, distribution, transfer, repeated or systematic of qualitatively or quantitatively insubstantial parts of the content of the database during operations manifestly exceeding normal use of the database by the user of the machine for his own needs,*
- any use of means to bypass technical protection measures for databases or software source code embedded in the boxes, in keeping according to laws & regulations on IP purposes.*

The latest updated version in force and binding of this document is the version available on demand.

Only the electronic version is maintained.

MANITOU BF S.A. Public limited company with a board of directors.

Head office: 430 rue de l'Aubinière - 44150 Ancenis - France

Share capital: €39,548,949

Entered in the Nantes Trade and Companies Register under number 857 802 508.

Tel.: +33 (0) 2 40 09 10 11

www.manitou.com

1 - OPERATING AND SAFETY INSTRUCTIONS

2 - DESCRIPTION

3 - MAINTENANCE

4 - ATTACHMENTS



1 - OPERATING AND SAFETY INSTRUCTIONS

TABLE OF CONTENTS

1 - OPERATING AND SAFETY INSTRUCTIONS

<i>INSTRUCTIONS TO THE COMPANY MANAGER</i>	4
THE SITE	4
THE OPERATOR	4
THE LIFT TRUCK	4
A - THE TRUCK'S SUITABILITY FOR THE JOB	4
B - ADAPTATION OF THE LIFT TRUCK TO STANDARD ENVIRONMENTAL CONDITIONS	4
C - MODIFICATION OF THE LIFT TRUCK	5
INSTRUCTIONS	5
MAINTENANCE	5
<i>INSTRUCTIONS FOR THE OPERATOR</i>	6
FOREWORD	6
GENERAL INSTRUCTIONS	6
A - OPERATOR'S MANUAL	6
B - AUTHORISATION FOR USE IN FRANCE	6
C - MAINTENANCE	6
D - MODIFICATION OF THE LIFT TRUCK	6
E - LIFTING PEOPLE	6
OPERATING INSTRUCTIONS UNLADEN AND LADEN	7
A - BEFORE STARTING THE LIFT TRUCK	7
B - DRIVER'S OPERATING INSTRUCTIONS	7
C - ENVIRONMENT	7
D - VISIBILITY	8
E - STARTING THE LIFT TRUCK	8
F - DRIVING THE LIFT TRUCK	9
G - STOPPING THE LIFT TRUCK	10
H - DRIVING THE LIFT TRUCK ON THE PUBLIC HIGHWAY	10
INSTRUCTIONS FOR HANDLING A LOAD	11
A - CHOICE OF ATTACHMENTS	11
B - WEIGHT OF LOAD AND CENTER OF GRAVITY	11
C - TRANSVERSE ATTITUDE OF THE LIFT TRUCK	11
D - PICKING UP A LOAD ON THE GROUND	12
PICKING UP AND LAYING DOWN A HIGH LOAD ON TIRES	12
<i>LIFT TRUCK MAINTENANCE INSTRUCTIONS</i>	14
GENERAL INSTRUCTIONS	14
MAINTENANCE	14
LUBRICANT LEVELS	14
ELECTRICITY	14
HYDRAULICS	15
WELDING	15
WASHING THE LIFT TRUCK	15
TRANSPORTING THE LIFT TRUCK	15

IF THE LIFT TRUCK IS NOT TO BE USED FOR A LONG TIME **16**

INTRODUCTION **16**

PREPARING THE LIFT TRUCK **16**

PROTECTING THE LIFT TRUCK **16**

BRINGING THE LIFT TRUCK BACK INTO SERVICE **16**

LIFT TRUCK DISPOSAL **17**

RECYCLING OF MATERIALS **17**

METALS..... 17

PLASTICS..... 17

RUBBER..... 17

GLASS..... 17

ENVIRONMENTAL PROTECTION **17**

WORN OR DAMAGED PARTS 17

USED OIL..... 17

USED BATTERIES..... 17

INSTRUCTIONS TO THE COMPANY MANAGER

THE SITE

- Proper management of lift truck's area of travel will reduce the risk of accidents:
 - Ground not unnecessarily uneven or obstructed,
 - No excessive slopes,
 - Pedestrian traffic controlled, etc.

THE OPERATOR

- Only qualified, authorized personnel can use the lift truck. This authorization is given in writing by the appropriate person in the establishment with respect to the use of lift trucks and must be carried permanently by the operator.

⚠ IMPORTANT ⚠

On the basis of experience, there are a number of possible situations in which operating the lift truck is contra-indicated. Such foreseeable abnormal uses, the main ones being listed below, are strictly forbidden.

- *The foreseeable abnormal behavior resulting from ordinary neglect, but does not result from any wish to put the machinery to any improper use.*
- *The reflex reactions of a person in the event of a malfunction, incident, fault, etc. during operation of the lift truck.*
- *Behavior resulting from application of the "principle of least action" when performing a task.*

- For certain machines, the foreseeable behavior of such persons as: apprentices, teenagers, handicapped persons, trainees tempted to drive a lift truck, operator tempted to operate a truck to win a bet, in competition or for their own personal experience.

The person in charge of the equipment must take these criteria into account when assessing whether or not a person will make a suitable driver.

THE LIFT TRUCK

A - THE TRUCK'S SUITABILITY FOR THE JOB

- MANITOU has ensured that this lift truck is suitable for use under the standard operating conditions defined in this operator's manual, with a **STATIC TEST COEFFICIENT 1.33** and a **DYNAMIC TEST COEFFICIENT OF 1**, as specified in harmonized norm **EN 1726-1** for mast trucks.
- Before commissioning, the company manager must make sure that the lift truck is appropriate for the work to be done, and perform certain tests (in accordance with current legislation).

B - ADAPTATION OF THE LIFT TRUCK TO STANDARD ENVIRONMENTAL CONDITIONS

- In addition to series equipment mounted on your lift truck, many options are available, such as: road lighting, stop lights, revolving light, reverse lights, reverse buzzer alarm, front light, rear light, etc.
- The operator must take into account the operating conditions to define the lift truck's signaling and lighting equipment. Contact your dealer.
- Take into account climatic and atmospheric conditions of the site of use.
 - Protection against frost (see: 3 - MAINTENANCE: LUBRICANTS AND FUEL).
 - Adaptation of lubricants (ask your dealer for information).
 - Do not work in refrigerated warehouses (battery life would then be 30 minutes).

⚠ IMPORTANT ⚠

For operation under average climatic conditions, i.e.: between -15 °C and +35 °C and a relative humidity less than 90%, correct levels of lubricants in all the circuits are checked in production.

For operation under more severe climatic conditions, before starting up, drain all circuits, then fill using suitable lubricants for the ambient temperatures.

- A lift truck operating in an area without fire extinguishing equipment must be equipped with an individual extinguisher. There are solutions, consult your dealer.

⚠ IMPORTANT ⚠

Your lift truck is designed for outdoor use under normal atmospheric conditions and indoor use in suitably aerated and ventilated premises.

It is forbidden to use the lift truck in areas where there is a risk of fire or potential explosion (e.g. Refineries, fuel or gas depots, stores of flammable products, etc.). Special equipment is available for use in such areas (ask your dealer for information).

- Our trucks comply with Directive 2004/108/EC concerning electromagnetic compatibility (EMC), and with the corresponding harmonized standard EN 12895. Their proper operation is no longer guaranteed if they are used within areas in which the electromagnetic fields exceed the limit specified by that standard (10 V/m).
- Directive 2002/44/EC requires company managers to not expose their employees to excessive vibration doses. There is no recognized code of measurement for comparing the machines of different manufacturers. The actual doses received cannot therefore be measured under actual operating conditions at the user's premises.

- The following are some tips for minimizing these vibration doses:
 - Select the most suitable lift truck and attachment for the intended use.
 - Adapt the seat adjustment to the operator's weight (according to lift truck model) and maintain it in good condition, as well as the cab suspension. Inflate the tires in accordance with recommendations.
 - Ensure that the operators adapt their operating speed to suit the conditions on site.
 - As far as possible, arrange the site in such a way as to provide a flat running surface and remove obstacles and harmful potholes.

C - MODIFICATION OF THE LIFT TRUCK

- For your own safety and that of others, you must not change the structure and settings of the various components used in your lift truck by yourself (hydraulic pressure, limiter calibration, engine speed, addition of extra equipment, addition of counterweights, unapproved attachments, alarm systems, etc.). In this event, the manufacturer cannot be held liable.

INSTRUCTIONS

- The operator's manual must always be in good condition and kept in the place provided on the lift truck and in the language used by the operator.
- The operator's manual and any plates or stickers which are no longer legible or are damaged, must be replaced immediately.

MAINTENANCE

- Maintenance or repairs other than those detailed in part: 3 - MAINTENANCE: SERVICING SCHEDULE must be carried out by qualified personnel (consult your dealer) and under the necessary safety conditions to maintain the health of the operator and any third party.

⚠ IMPORTANT ⚠

*Your lift truck must be inspected periodically to ensure that it remains in conformity.
The frequency of this inspection is defined by current legislation in the country in which the lift truck is used.*

INSTRUCTIONS FOR THE OPERATOR

FOREWORD

⚠ IMPORTANT ⚠

The risk of accident whilst using, servicing or repairing your lift truck can be reduced if you follow the safety instructions and safety measures detailed in these instructions.

Failure to respect the safety and operating instructions, or instructions for repairing or servicing your lift truck, may lead to serious, even fatal accident.

In order to reduce or avoid any danger with a MANITOU-approved attachment, follow the instructions of paragraph: 4 - ADAPTABLE ATTACHMENTS IN OPTION ON THE RANGE: INTRODUCTION.

- Only the operations and maneuvers described in this operator's manual must be performed. The manufacturer cannot predict all possible risky situations. Consequently, the safety instructions given in the operator's manual and on the lift truck itself are not exhaustive.
- At any time, as an operator, you must envisage, within reason, the possible risk to yourself, to others or to the lift truck itself when you use it.

GENERAL INSTRUCTIONS

A - OPERATOR'S MANUAL

- Read the operator's manual carefully.
- The operator's manual must always be in good condition and in the place provided for it on the lift truck.
- You must report any plates and stickers which are no longer legible or which are damaged.

B - AUTHORISATION FOR USE IN FRANCE

(or see current legislation in other countries)

- Only qualified, authorized personnel can use the lift truck. This authorization is given in writing by the appropriate person in the establishment with respect to the use of lift trucks and must be carried permanently by the operator.
- The operator is not competent to authorize the driving of the lift truck by another person.

C - MAINTENANCE

- The operator must immediately advise his superior if his lift truck is not in good working order or does not comply with the safety notice.
- The operator is prohibited from carrying out any repairs or adjustments himself, unless he has been trained for this purpose. He must keep the lift truck properly cleaned if this is among his responsibilities.
- The operator is responsible for carrying out daily maintenance operations (see: 3 - MAINTENANCE: SERVICING SCHEDULE).
- The operator must ensure tires are adapted to the nature of the ground (see area of the contact surface of the tires in the chapter: 2 - DESCRIPTION: TIRES). There are optional solutions, consult your dealer.

⚠ IMPORTANT ⚠

Do not use the lift truck if the tires are damaged or excessively worn, as this could put your own safety or that of others at risk, or cause damage to the lift truck itself.

D - MODIFICATION OF THE LIFT TRUCK

- For your own safety and that of others, you must not change the structure and settings of the various components used in your lift truck by yourself (hydraulic pressure, limiter calibration, engine speed, addition of extra equipment, addition of counterweights, unapproved attachments, alarm systems, etc.). In this event, the manufacturer cannot be held liable.

E - LIFTING PEOPLE

- The use of working equipment and load lifting attachments to lift people is:
 - Either forbidden
 - Or authorized exceptionally and under certain conditions (see current regulations in the country in which the lift truck is used).

A - BEFORE STARTING THE LIFT TRUCK

- Carry out daily maintenance (see: 3 - MAINTENANCE: MAINTENANCE SCHEDULE).
- Make sure that the driver's cab is clean, particularly the floor and floor mat. Check that no movable object may hinder the operation of the lift truck.
- Make sure the lights, indicators and windscreen wipers are working properly.
- Make sure the rear view mirrors are in good condition, clean and properly adjusted.
- Make sure the horn works.

B - DRIVER'S OPERATING INSTRUCTIONS

- Whatever his experience, the operator is advised to familiarize himself with the position and operation of all the controls and instruments before operating the lift truck.
- Wear clothes suited for driving the lift truck, avoid loose clothes.
- Make sure you have the appropriate protective equipment for the task to be performed.
- Prolonged exposure to high noise levels may cause hearing problems. It is recommended to wear ear muffs to protect against excessive noise.
- Always face the lift truck when getting into and leaving the driving seat and use the handle(s) provided for this purpose. Do not jump from the lift truck to get down.
- Always pay attention when using the lift truck. Do not listen to the radio or music using headphones or earphones.
- Never operate the lift truck when hands or feet are wet or soiled with greasy substances.
- For increased comfort, adjust the seat to your requirements and adopt the correct position in the driver's cab.



Under no circumstances must the seat be adjusted while the lift truck is moving.

- The operator must always be in his normal position in the driver's cab. It is prohibited to have arms or legs, or generally any part of the body, protruding from the driver's cab of the lift truck.
- The safety belt must be worn and adjusted to the operator's size.
- The control units must never in any event be used for any other than their intended purposes (e.g. climbing onto or down from the lift truck, portmanteau, etc.).
- If the control components are fitted with a forced operation (lever lock) device, it is forbidden to leave the cab without first putting these controls in neutral.
- It is prohibited to carry passengers either on the lift truck or in the cab.

C - ENVIRONMENT

- Comply with site safety regulations.
- If you have to use the lift truck in a dark area or at night, make sure it is equipped with working lights.
- During handling operations, make sure that no one is in the way of the lift truck and its load.
- Do not allow anybody to come near the working area of the lift truck or pass beneath an elevated load.
- When using the lift trucks on a transverse slope, before lifting the mast, follow the instructions given in the paragraph: INSTRUCTIONS FOR HANDLING A LOAD: C - TRANSVERSE ATTITUDE OF THE LIFT TRUCK.
- Travelling on a longitudinal slope:
 - Drive and brake gently.



- Moving without load: Forks or attachment facing downhill.

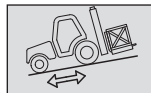

- Moving with load: Forks or attachment facing uphill.

- Take into account the lift truck's dimensions and its load before trying to negotiate a narrow or low passageway.
- Never move onto a loading platform without having first checked:
 - That it is suitably positioned and made fast.
 - That the unit to which it is connected (wagon, lorry, etc.) will not shift.
 - That this platform is prescribed for the total weight of the lift truck to be loaded.
 - That this platform is prescribed for the size of the lift truck.
- Never move onto a foot bridge, floor or freight lift, without being certain that they are prescribed for the weight and size of the lift truck to be loaded and without having checked that they are in sound working order.
- Be careful in the area of loading bays, trenches, scaffolding, soft ground and manholes.
- Make sure the ground is stable and firm under the wheels before lifting the load.
- Make sure that the scaffolding, loading platform, pilings or ground is capable of bearing the load.

- Never stack loads on uneven ground, they may tip over.
- The load or the attachment must not be left just above a structure for long periods at a time because of the descending mast. In such a case, a constant watch must be kept and the height of the forks or the attachment readjusted if necessary.
- When working near aerial lines, ensure that the safety distance is sufficient between the working area of the lift truck and the aerial line.

⚠ IMPORTANT ⚠

You must consult your local electrical agency.

You could be electrocuted or seriously injured if you operate or park the lift truck too close to power cables.

In the event of high winds, do not carry out handling work that jeopardizes the stability of the lift truck and its load, particularly if the load catches the wind badly.

D - VISIBILITY

- The safety of people within the lift truck's working area, as well as that of the lift truck itself and the operator are depend on good operator visibility of the lift truck's immediate vicinity in all situations and at all times.
- This lift truck has been designed to allow good operator visibility (direct or indirect by means of rear-view mirrors) of the immediate vicinity of the lift truck while traveling with no load and with the mast in the transport position.
- Special precautions must be taken if the size of the load restricts visibility towards the front:
 - Moving in reverse,
 - Site layout,
 - Assisted by a person directing the maneuver (while standing outside the truck's area of travel), making sure to keep this person clearly in view at all times,
 - In any event, avoid reversing over long distances.
- If visibility of your road is inadequate, ask someone to assist by directing the maneuver (while standing outside the truck's area of travel), making sure to keep this person clearly in view at all times.
- Keep all components affecting visibility in a clean, properly adjusted state and in good working order (e.g. windscreens, windows, windscreen wipers, windscreen washers, driving and work lights, rear-view mirrors).

E - STARTING THE LIFT TRUCK

SAFETY INSTRUCTIONS

⚠ IMPORTANT ⚠

The lift truck must only be started up or maneuvered when the operator is sitting in the driver's cab, with his seat belt adjusted and fastened.

- If necessary to tow the lift truck, the transmission must be placed in the neutral position (see: 3 - MAINTENANCE: SERVICING SCHEDULE).

INSTRUCTIONS

- Check the closing and locking of the hood(s).
- Ensure that the forward/reverse selector is set to neutral.
- Turn the ignition key to the position I to switch on the ignition.
- Check all control instruments at regular intervals during use, so as to quickly detect any faults and to be able to correct them without any delay.
- If an instrument does not show the correct display, switch off the ignition and immediately carry out the necessary operations.

F - DRIVING THE LIFT TRUCK

SAFETY INSTRUCTIONS

⚠ IMPORTANT ⚠

Operators' attention is drawn to the risks involved in using the lift truck, in particular:

- Risk of losing control.

- Risk of losing lateral and frontal stability of the lift truck.

The operator must remain in control of the lift truck.

In the event of the lift truck overturning, do not try to leave the cabin during the incident.

YOUR BEST PROTECTION IS TO STAY STRAPPED INSIDE THE CAB.

- Observe the company's traffic regulations or, by default, the public highway code.
- Do not carry out operations which exceed the capacities of your lift truck or attachments.
- Always drive the lift truck with the forks or attachment to the transport position, i.e. at 300 mm from the ground and the carriage sloping backwards.
- Only carry loads which are balanced and properly anchored to avoid any risk of a load falling off.
- Ensure that pallets, crates, etc, are in good condition and suitable for the load to be lifted.
- Familiarize yourself with the lift truck in the environment in which it will be used.
- Ensure that the service brakes are working properly.
- When laden, the lift truck must not travel at speeds in excess of 12 km/h.
- Drive smoothly at an appropriate speed for the operating conditions (land configuration, load on the lift truck).
- Do not use the hydraulic mast controls when the lift truck is moving.
- Do not maneuver the lift truck with the mast in the raised position unless under exceptional circumstances and then with extreme caution, at very low speed and using gentle braking. Ensure that visibility is adequate.
- Take bends slowly.
- In all circumstances make sure you are in control of your speed.
- On damp, slippery or uneven terrain, drive slowly.
- Brake gently, never abruptly.
- Only use the lift truck's forward/reverse selector from a stationary position and never do so abruptly.
- Do not drive with your foot on the brake pedal.
- Always remember that hydrostatic type steering is extremely sensitive to movement of the steering wheel, so turn it gently and not jerkily.
- Do not leave the ignition switched on too long when not needed.
- Do not leave the cab when the lift truck has a raised load.
- Look where you are going and always make sure you have good visibility along the route.
- Use the rear-view mirrors frequently.
- Drive round obstacles.
- Never drive on the edge of a ditch or steep slope.
- It is dangerous to use two lift trucks simultaneously to handle heavy or voluminous loads, since this operation requires particular precautions to be taken. It must only be used exceptionally and after risk analysis.
- The ignition switch has an emergency stop mechanism in case of an operating anomaly occurring in the case of lift trucks not fitted with a punch-operated cut-out.

INSTRUCTIONS

- Always drive the lift truck with the forks or attachment to the transport position, i.e. at 300 mm from the ground and the carriage sloping backwards.
- Release the hand brake.
- Shift the forward/reverse selector to the selected direction of travel and accelerate gradually until the lift truck moves off.

G - STOPPING THE LIFT TRUCK

SAFETY INSTRUCTIONS

- Never leave the ignition key in the lift truck during the operator's absence.
- When the lift truck is stationary, or if the operator has to leave his cab (even for a moment), place the forks or attachment on the ground, apply the parking brake and place the forward/reverse selector in neutral.
- Make sure that the lift truck is not stopped in any position that will interfere with the traffic flow and at less than one meter from the track of a railway.
- In the event of prolonged parking on a site, protect the lift truck from bad weather, disconnect and fully recharge the battery, close and lock all means of access to the lift truck (doors, windows, covers, etc.). If parked for a period of several months in an area at around 20°C allow for charging the battery at least once every month.

INSTRUCTIONS

- Park the lift truck on level ground or on an incline less than 15%.
- Set the forward/reverse selector to neutral.
- Apply the parking brake.
- Lower the forks or attachment to rest on the ground.
- When using an attachment with a grab or jaws, or a bucket with hydraulic opening, close the attachment fully.
- Switch off the ignition with the ignition key.
- Remove the ignition key.
- Disconnect the battery plug.
- Recharge the battery if necessary.
- Lock all the accesses to the lift truck (doors, windows, cowls...).

H - DRIVING THE LIFT TRUCK ON THE PUBLIC HIGHWAY

SAFETY INSTRUCTIONS

- Operators driving on the public highway must comply with current highway code legislation.
- The lift truck must comply with current road legislation. If necessary, there are optional solutions. Contact your dealer.

INSTRUCTIONS

- Make sure the revolving light is in place, switch it on and verify its operation.
- Make sure the lights, indicators and windscreen wipers are working properly.
- Switch off the working headlights if the lift truck is fitted with them.
- Place the attachment 300 mm from the ground.

DRIVING THE LIFT TRUCK WITH A FRONT-MOUNTED ATTACHMENT

- You must comply with current regulations in your country, covering the possibility of driving on the public highway with a front-mounted attachment on your lift truck.
- If road legislation in your country authorizes circulation with a front-mounted attachment, you must at least:
 - Protect and report any sharp and/or dangerous edges on the attachment (see: 4 - ADAPTABLE ATTACHMENTS IN OPTION ON THE RANGE: ATTACHMENT SHIELDS).
 - The attachment must not be loaded.
 - Make sure that the attachment does not mask the lighting range of the forward lights.
 - Make sure that current legislation in your country does not require other obligations.

For lift trucks equipped with a towing system

OPERATING THE LIFT TRUCK WITH A TRAILER

- For using a trailer, observe the regulations in force in your country (maximum travel speed, braking, maximum weight of trailer, etc.).
- Do not forget to connect the trailer's electrical equipment to that of the lift truck.
- The trailer's braking system must comply with current legislation.
- If pulling a trailer with assisted braking, the tractor lift truck must be equipped with a trailer braking mechanism. In this case, do not forget to connect the trailer braking equipment to the lift truck.
- The vertical force on the towing hook must not exceed the maximum authorized by the manufacturer (consult the manufacturer's plate on your lift truck).
- The authorized gross vehicle weight must not exceed the maximum weight authorized by the manufacturer (consult the manufacturer's plate on your lift truck).

IF NECESSARY, CONSULT YOUR DEALER.

INSTRUCTIONS FOR HANDLING A LOAD

A - CHOICE OF ATTACHMENTS

- Only attachments approved by MANITOU can be used on its lift trucks.
- Make sure the attachment is appropriate for the work to be done (see: 4 - ADAPTABLE ATTACHMENTS IN OPTION ON THE RANGE).
- Make sure the attachment is correctly installed and locked onto the lift truck carriage.
- Make sure that your lift truck attachments work properly.
- Comply with the load chart limits for the lift truck for the attachment used.
- Do not exceed the rated capacity of the attachment.
- Never lift a load in a sling without the attachment provided for the purpose. There are optional solutions; contact your dealer.

B - WEIGHT OF LOAD AND CENTER OF GRAVITY

- Before taking up a load, you must know its weight and its center of gravity.
- The load chart for your lift truck is valid for a load in which the longitudinal position of the center of gravity is 500 mm or 600 mm from the base of the forks (according to the model of lift truck) (Fig. B1). For a higher center of gravity, contact your dealer.
- For irregular loads, determine the transverse center of gravity before any movement (fig. B2) and set it in the longitudinal axis of the lift truck.

⚠ IMPORTANT ⚠

It is forbidden to move a load heavier than the effective capacity defined on the lift truck load chart.

For loads with a moving center of gravity (e.g. liquids), take account of the variations in the center of gravity in order to determine the load to be handled and be extra vigilant and careful to limit these variations as far as possible.

C - TRANSVERSE ATTITUDE OF THE LIFT TRUCK

The transverse attitude is the transverse slope of the chassis with respect to the horizontal.

Raising the mast reduces the lift truck's lateral stability. The transverse attitude must be horizontal with the mast in the down position.

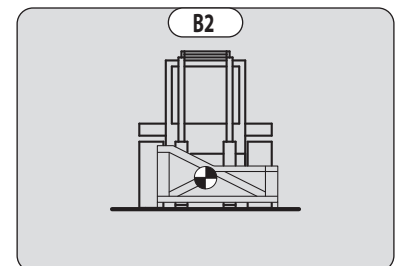
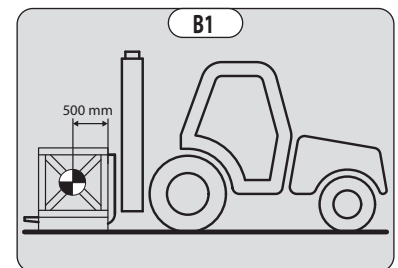

D - PICKING UP A LOAD ON THE GROUND

- Approach the lift truck perpendicular to the load, with the forks in a horizontal position (fig. D1).
- Adjust the spread and centering of the forks relative to the load to ensure its stability (fig. D2) (optional solutions exist, consult your dealer).
- Never lift a load with a single fork.

⚠ IMPORTANT ⚠

Beware of the risks of trapping or crushing limbs when manually adjusting the forks.

- Move the lift truck forward slowly (1) and bring the forks tight up against the front of the load (fig. D3), if necessary, slightly lift the mast (2) while taking up the load.
- Bring the load into the transport position.
- Tilt the load far enough backwards to ensure stability (loss of load on braking or going downhill).

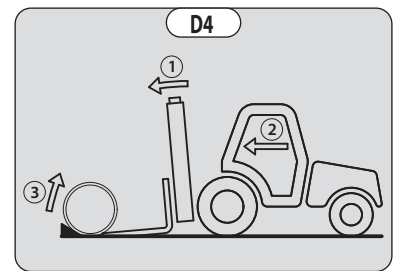
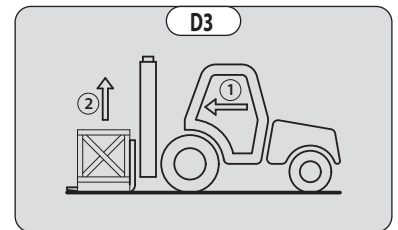
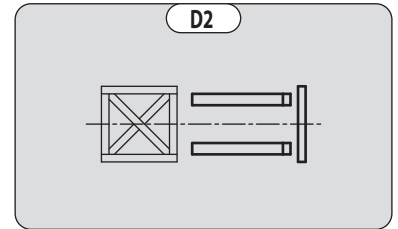
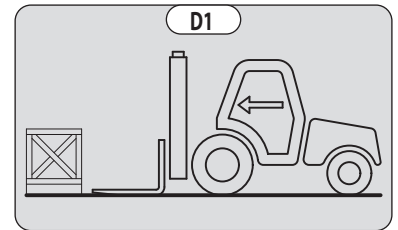

FOR A NON-PALLETIZED LOAD

- Tilt the carriage (1) forwards and move the lift truck slowly forwards (2), to insert the fork under the load (fig. D4) (block the load if necessary).
- Continue to move the lift truck forwards (2) tilting the carriage (3) (fig. D4) backwards to position the load on the forks.
- Check the load's longitudinal and lateral stability.

PICKING UP AND LAYING DOWN A HIGH LOAD ON TIRES

⚠ IMPORTANT ⚠

You must not, under any circumstances, raise the mast if you have not checked the transverse attitude of the lift truck (see: INSTRUCTIONS FOR HANDLING A LOAD: C - TRANSVERSE ATTITUDE OF THE LIFT TRUCK).

REMINDER: Make sure that the following operations can be performed with good visibility (see: OPERATIONS INSTRUCTIONS UNLADEN AND LADEN: D - VISIBILITY).

PICKING UP A HIGH LOAD ON TIRES

- Ensure that the forks will easily pass under the load.
- Keeping the mast vertical (1), advance the lift truck and raise the forks to level with the load (2) (fig. E1).
- Maneuver carefully and gently to bring the forks tight up against the front of the load (fig. E2).
- Apply the parking brake and place the forward/reverse selector in neutral.

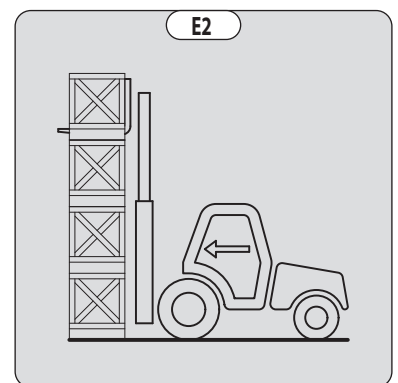
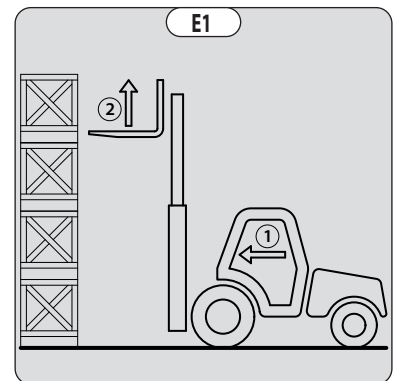

- Slightly lift the load (1) (fig. E3).
- Incline the carriage (2) backwards to stabilize the load (fig. E3).

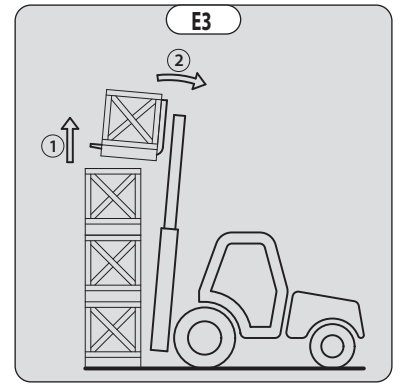

- Reverse the lift truck (1) very carefully and gently to free the load.
- Lower the mast (2) to bring the load into the transport position (fig. E4).

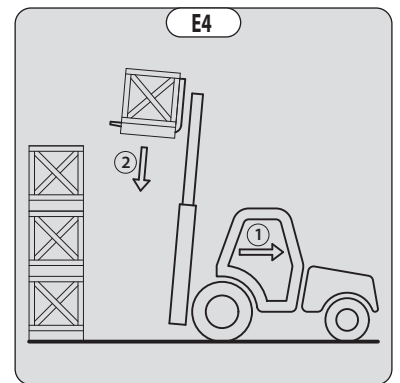

LAYING A HIGH LOAD ON TYRES

- Approach the load in the transport position in front of the pile (fig. E5).
- Raise the mast (1) until the load is higher than the pile and move the lift truck forward (2) (fig. E6) very carefully and gently, until the load is over the pile.
- Apply the parking brake and place the forward/reverse selector in neutral.
- Place the load in a horizontal position by tilting the mast forwards (1) and lay it down on the pile (2) while checking the correct positioning of the load (fig. E7).
- Reverse the lift truck (1) very slowly and carefully to free the forks (fig. E8).
- Set the forks in the transport position.

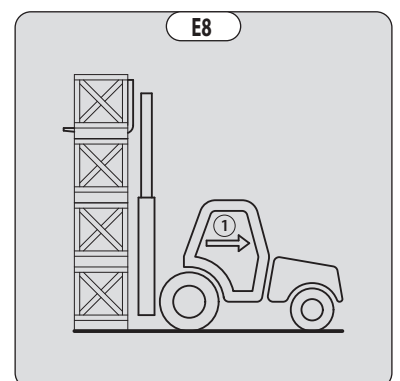
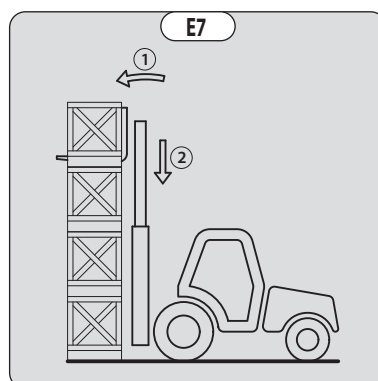
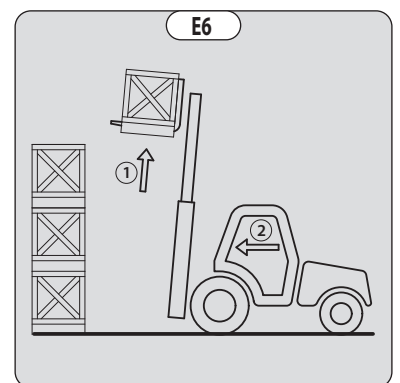
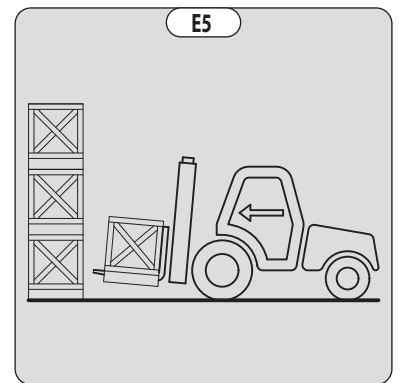

LIFT TRUCK MAINTENANCE INSTRUCTIONS

GENERAL INSTRUCTIONS

NOTE: For any operations other than regular maintenance (see: 3 - MAINTENANCE: SERVICING SCHEDULE), consult your dealer.

- Wear clothes suitable for the maintenance of the lift truck, avoid wearing jewelry and loose clothes. Tie and protect your hair, if necessary.
- Switch off the ignition with the ignition switch and remove the ignition key before working on the lift truck.
- Read the operator's manual carefully.
- Carry out all repairs immediately, even if the repairs concerned are minor.
- Repair all leaks immediately, even if the leak concerned is minor.
- Make sure that the disposal of process materials and of spare parts is carried out in total safety and in an ecological way.
- Be careful of the risk of burning and splashing of battery acid.

MAINTENANCE

- Perform the periodic service (see: 3 - MAINTENANCE: SERVICING SCHEDULE) to keep your lift truck in good working conditions. Failure to perform the periodic service may annul the contractual guarantee.

MAINTENANCE LOGBOOK

- The maintenance operations carried out in accordance with the recommendations given in part: 3 - MAINTENANCE: SERVICING SCHEDULE and the other inspection, servicing or repair operations or modifications performed on the lift truck or its attachments shall be recorded in a maintenance logbook. The entry for each operation shall include details of the date of the works, the names of the individuals or companies having performed them, the type of operation and its frequency, if applicable. The part numbers of any lift truck items replaced shall also be indicated.

LUBRICANT LEVELS

- Use the recommended lubricants (never use contaminated lubricants).

ELECTRICITY

NOTE: It is forbidden to carry out any work on the electrical circuit other than the operations described in part: 3 - MAINTENANCE: SERVICING SCHEDULE.

⚠ IMPORTANT ⚠

Never add acid to the battery.

The polarity of the battery must not be reversed under any circumstances.

Handling and servicing a battery can be dangerous, take the following precautions:

- *Wear protective goggles, gloves, an apron and acid-resistant clothing.*
 - *Remove rings, watches, bracelets and any clothing incorporating metal.*
 - *Keep the battery horizontal.*
 - *Never smoke or work near a naked flame.*
 - *Work in a well-ventilated area.*
 - *Wash your hands each time you work on the battery, as acid is corrosive.*
 - *In the event of electrolyte being spilled onto the skin or splashed in the eyes, rinse thoroughly with cold water for 15 minutes and call a doctor.*
- Only use electrically insulated tools.
 - Do not smoke or approach the lift truck with a flame while charging the battery (because of hydrogen emissions).
 - Do not place metal items on the battery.
 - Disconnect the battery before working on the electrical circuit.
 - Keep the battery horizontal at all times.
 - When changing the battery, use only batteries that are suitable for the weight, size and capacity of the lift truck (see: 2 - DESCRIPTION: SPECIFICATIONS).
 - Top up the electrolyte level only with distilled or demineralized water.

HYDRAULICS

NOTE: It is forbidden to carry out any work on the hydraulic circuit other than the operations described in part: 3 - MAINTENANCE: SERVICING SCHEDULE.

⚠ IMPORTANT ⚠

It is dangerous to change the setting and remove the BALANCING VALVES or SAFETY VALVES which may be fitted to your lift truck cylinders.

*The HYDRAULIC ACCUMULATORS that may be fitted on your lift truck are pressurized units.
Removing these accumulators and their pipework is dangerous.*

Such operations must only be performed by approved personnel (consult your dealer).

- Do not attempt to loosen unions, hoses or any hydraulic components when the circuit is under pressure.

WELDING

⚠ IMPORTANT ⚠

It is forbidden to carry out electric welding on the lift truck as this risks damaging the electrical components, in particular the speed controller (consult your dealer).

WASHING THE LIFT TRUCK

NOTE: It is forbidden to carry out any washing operation other than those described in part: 3 - MAINTENANCE: SERVICING SCHEDULE, consult your dealer.

⚠ IMPORTANT ⚠

Disconnect and protect the battery plug before carrying out any washing operation.

Do not wet electrical components

Do not use a steam or pressurized water jet cleaner.

- The battery must be kept clean and dry at all times to avoid self-discharge and leakage currents (see 3 - MAINTENANCE: SERVICING SCHEDULE).
- Do not cover the battery with a plastic sheet, as this would cause a build-up of static electricity and could cause an explosion.
- Clean the lift truck or at least the area concerned before any intervention.
- During washing, avoid the articulations and electrical components and connections.
- If necessary, protect against penetration of water, steam or cleaning agents, components susceptible to damage, particularly electrical components and connections.
- Clean the lift truck of any oil or grease stains.

TRANSPORTING THE LIFT TRUCK

⚠ IMPORTANT ⚠

Transporting the lift truck involves real risks for the operator and others involved.

- Towing, slinging or transporting the lift truck (see 3 - MAINTENANCE: SERVICING SCHEDULE).

IF THE LIFT TRUCK IS NOT TO BE USED FOR A LONG TIME

INTRODUCTION

The following recommendations are intended to prevent the lift truck from being damaged when it is withdrawn from service for an extended period.

⚠ IMPORTANT ⚠

Procedures to follow if the lift truck is not to be used for a long time and for starting it up again afterwards must be performed by your dealership. This long-term storage period must not exceed 12 months.

PREPARING THE LIFT TRUCK

- Clean the lift truck thoroughly.
- Check and repair any oil or acid leaks.
- Replace or repair any worn or damaged parts.
- Wash the painted surfaces of the lift truck in clear and cold water and wipe them.
- Touch up the paintwork if necessary.
- Shut down the lift truck (see: OPERATING INSTRUCTIONS UNLADEN AND LADEN).
- Make sure the mast cylinder rods are all in the retracted position.
- Release the pressure in the hydraulic circuits.

PROTECTING THE LIFT TRUCK

- Disconnect the battery and store it in a safe place away from the cold, after charging it to a maximum (see: 3 - MAINTENANCE: SERVICING SCHEDULE).
- Set the lift truck on axle stands so that the tires are not in contact with the ground and release the handbrake.
- Protect cylinder rods which will not be retracted, from corrosion.
- Wrap the tires.

NOTE: If the lift truck is to be stored outdoors, cover it with a waterproof tarpaulin.

BRINGING THE LIFT TRUCK BACK INTO SERVICE

- Refit and reconnect the battery (see: 3 - MAINTENANCE: MAINTENANCE SCHEDULE).
- Remove the protection from the cylinder rods.
- Carry out daily maintenance (see: 3 - MAINTENANCE: MAINTENANCE SCHEDULE).
- Put the handbrake on and remove the axle stands.
- Lubricate the lift truck completely (see: 3 - MAINTENANCE: SERVICING SCHEDULE).
- Start up the lift truck, following the safety instructions and regulations (see: OPERATING INSTRUCTIONS UNLADEN AND LADEN).
- Run all the mast's hydraulic movements, concentrating on the ends of travel for each cylinder.

LIFT TRUCK DISPOSAL

MANITOU complies with the regulations deriving from Directive 2000/53/EC relating to lift truck end-of-life. This lift truck contains no substances or materials forbidden by Directive 2000/53/EC.

NOTE: Make sure that the disposal of process materials and of spare parts is carried out in total safety and in an ecological way.

Consult your dealer before disposing of the lift truck.

RECYCLING OF MATERIALS

METALS

- Metals are 100 % recoverable and recyclable.

PLASTICS

- Plastic parts are identified with a marking in accordance with current regulations.
- A limited range of materials is used to simplify the recycling process.
- The majority of plastic components are made of "thermoplastic" plastics, that are easily recycled by melting, granulating or grinding.

RUBBER

- Tires and seals can be ground for use in cement manufacture or to obtain reusable granules.

GLASS

- Glass items can be removed and collected for processing by glaziers.

ENVIRONMENTAL PROTECTION

By entrusting the maintenance of your lift truck to the MANITOU network, the risk of pollution is limited and the contribution to environmental protection contribution is made.

WORN OR DAMAGED PARTS

- Do not dump them in the countryside.
- MANITOU and its network have signed-up to a scheme of environmental protection through recycling.

USED OIL

- The MANITOU network organizes the collection and processing of used oil products.
- By handing over your waste oil to MANITOU, the risk of pollution is limited.

USED BATTERIES

- Do not throw away batteries, as they contain metals that are harmful for the environment.
- Return them to the MANITOU network or any other approved collection point.

NOTE: MANITOU seeks to manufacture lift trucks that provide the best performance and limit polluting emissions.

2 - DESCRIPTION

TABLE OF CONTENTS

2 - DESCRIPTION

<i>EC DECLARATION OF CONFORMITY (ME 315 48V S3 / ME 316 48V S3 / ME 318 48V S3 / ME 320 48V S3)</i>	4
<i>UKCA DECLARATION OF CONFORMITY (ME 315 48V S3 / ME 316 48V S3 / ME 318 48V S3 / ME 320 48V S3)</i>	6
<i>SAFETY PLATES AND STICKERS</i>	8
<i>IDENTIFICATION OF THE LIFT TRUCK</i>	10
<i>CHARACTERISTICS</i>	12
<i>MAST CHARACTERISTICS AND LOAD CHARTS</i>	14
<i>BATTERY CHARACTERISTICS</i>	16
<i>FRONT AND REAR TIRES</i>	17
<i>INSTRUMENTS AND CONTROLS</i>	18

EC DECLARATION OF CONFORMITY (ME 315 48V S3 / ME 316 48V S3 / ME 318 48V S3 / ME 320 48V S3)

This document is a specimen of the EC declaration of conformity mirroring the content of the original declaration provided with the machine.

This specimen and the original document may contain data fields which does not apply to the machine. These fields are left blank if not relevant.

See the original certificates for all relevant values for your machine.

1) **DÉCLARATION «CE» DE CONFORMITÉ (originale)** **«EC» DECLARATION OF CONFORMITY (original)**

2) Constructeur, *Manufacturer* : **MANITOU BF**

3) Adresse, *Address* : **430, RUE DE L'AUBINIÈRE - B.P 10249
44158 - ANCENIS - CEDEX - FRANCE**

4) Titulaire du dossier technique, *Holder of the technical file* : **MANITOU BF**

3) Adresse, *Address* : **430, RUE DE L'AUBINIÈRE - B.P 10249
44158 - ANCENIS - CEDEX - FRANCE**

5) Le constructeur déclare que la machine décrite ci-après, *The manufacturer declares that the machine described below* :

ME 315 48V S3

ME 316 48V S3

ME 318 48V S3

ME 320 48V S3

6) Est conforme aux directives suivantes et à leurs transpositions en droit national (si applicables),
Complies with the following directives and their transpositions into national law (if applicable) :

2006/42/CE

7) Pour les machines annexe IV, *For annex IV machines* : Non applicable

8) Numéro d'attestation, *Certificate number* : Non applicable

9) Organisme notifié, *Notified body* : Non applicable

2000/14/CE + 2005/88/CE

10) Procédure appliquée, *Applied procedure* :

9) Organisme notifié, *Notified body* :

11) Niveau de puissance acoustique, *Sound power level* :

12) Mesuré, *Measured* : dB (A)

13) Garanti, *Guaranteed* : dB (A)

2014/30/UE

14) Normes harmonisées utilisées, *Harmonised standards used* :

EN 12895

15) Normes ou dispositions techniques utilisées, *Standards or technical provisions used* :

-

16) Fait à, *Done at* :

17) Date, *Date* :

18) Nom du signataire, *Name of signatory* :

19) Fonction, *Function* :

20) Société, *Company* :

21) Signature, *Signature* :

- bg :** 1) удостоверение за « CE » съответствие (оригинална), 2) Фирмата, 3) Адрес, 4) Техническо досие, 5) Фабрикант на описаната по-долу машина, 6) Обявява, че тази машина, 7) Отговаря на следните директиви и на тяхното съответствие национално право, 8) За машините към допълнение IV, 9) Номер на удостоверението, 10) Наименувана фирма, 15) хармонизирани стандарти използвани, 16) стандарти или технически правила, използвани, 17) Изработено в, 18) Дата, 19) Име на разписалия се, 20) Функция, 21) Функция.
- cs :** 1) **ES prohlášení o shodě (původní)**, 2) Název společnosti, 3) Adresa, 4) Technická dokumentace, 5) Výrobce níže uvedeného stroje, 6) Prohlašuje, že tento stroj, 7) Je v souladu s následujícími směrnicemi a směrnicemi transponovanými do vnitrostátního práva, 8) Pro stroje v příloze IV, 9) Číslo certifikátu, 10) Notifikační orgán, 15) harmonizované normy použity, 16) Norem a technických pravidel používaných, 17) Místo vydání, 18) Datum vydání, 19) Jméno podepsaného, 20) Funkce, 21) Podpis.
- da :** 1) **EF Overensstemmelseserklæring (original)**, 2) Firmaet, 3) Adresse, 4) tekniske dossier, 5) Konstruktor af nedenfor beskrevne maskine, 6) Erklærer, at denne maskine, 7) Overholder nedennævnte direktiver og disses gennemførelse til national ret, 8) For maskiner under bilag IV, 9) Certificat nummer, 10) Bemyndigede organ, 15) harmoniserede standarder, der anvendes, 16) standarder eller tekniske regler, 17) Udfærdiget i, 18) Dato, 19) Underskrivers navn, 20) Funktion, 21) Underskrift.
- de :** 1) **EG-Konformitätserklärung (original)**, 2) Die Firma, 3) Adresse, 4) Technischen Unterlagen, 5) Hersteller der nachfolgend beschriebenen Maschine, 6) Erklärt, dass diese Maschine, 7) den folgenden Richtlinien und deren Umsetzung in die nationale Gesetzgebung entspricht, 8) Für die Maschinen laut Anhang IV, 9) Bescheinigungsnummer, 10) Benannte Stelle, 15) angewandten harmonisierten Normen, 16) angewandten sonstigen technischen Normen und Spezifikationen, 17) Ausgestellt in, 18) Datum, 19) Name des Unterzeichners, 20) Funktion, 21) Unterschrift.
- el :** 1) **Δήλωση συμμόρφωσης CE (πρωτότυπο)**, 2) Η εταιρεία, 3) Διεύθυνση, 4) τεχνικό φάκελο, 5) Κατασκευάστρια του εξής περιγραφόμενου μηχανήματος, 6) Δηλώνει ότι αυτό το μηχάνημα, 7) Είναι σύμφωνο με τις εξής οδηγίες και τις προσαρμογές τους στο εθνικό δίκαιο, 8) Για τα μηχανήματα παραρτήματος IV, 9) Αριθμός δήλωσης, 10) Κοινοποιημένος φορέας, 15) εναρμονισμένα πρότυπα που χρησιμοποιούνται, 16) Πρότυπα ή τεχνικούς κανόνες που χρησιμοποιούνται, 16) Είναι σύμφωνο με τα εξής πρότυπα και τεχνικές διατάξεις, 17) Εν, 18) Ημερομηνία, 19) Όνομα του υπογράφοντος, 20) Θέση, 21) Υπογραφή.
- es :** 1) **Declaración DE de conformidad (original)**, 2) La sociedad, 3) Dirección, 4) expediente técnico, 5) Constructor de la máquina descrita a continuación, 6) Declara que esta máquina, 7) Está conforme a las siguientes directivas y a sus transposiciones en derecho nacional, 8) Para las máquinas anexo IV, 9) Número de certificación, 10) Organismo notificado, 15) normas armonizadas utilizadas, 16) Otras normas o especificaciones técnicas utilizadas, 17) Hecho en, 18) Fecha, 19) Nombre del signatario, 20) Función, 21) Firma.
- et :** 1) **EÜ vastavusdeklaratsioon (algupärane)**, 2) Äriühing, 3) Aadress, 4) Tehniline dokumentatsioon, 5) Seadme tootja, 6) Kinnitab, et see toode, 7) On vastavuses järgmiste direktiivide ja nende riigisisese õigussesse ülevõtmiseks vastuvõetud õigusaktidega, 8) IV lisas loetletud seadmete puhul, 9) Tunnistuse number, 10) Sertifitseerimisasutus, 15) kasutatud ühtlustatud standardite, 16) Muud standardites või spetsifikatsioonides kasutatakse, 17) Väljaandmise koht, 18) Väljaandmise aeg, 19) Allkirjastaja nimi, 20) Amet, 21) Allkiri.
- fi :** 1) **EY-vaatimustenmukaisuusvakuutus (alkuperäiset)**, 2) Yritys, 3) Osoite, 4) teknisen eritelmän, 5) Jäljessä kuvaton koneen valmistaja, 6) Vakuuttaa, että tämä kone, 7) Täyttää seuraavien direktiivien sekä niitä vastaavien kansallisten säännösten vaatimukset, 8) Liitteen IV koneiden osalta, 9) Todistuksen numero, 10) Ilmoitettu laitos, 15) yhdenmukaistettuja standardeja käytetään, 16) muita standardeja tai eritelmät, 17) Paikka, 18) Aika, 19) Allekirjoittajan nimi, 20) Toimi, 21) Allekirjoitus.
- ga :** 1) **« CE » dearbhú comhréireachta (bunaidh)**, 2) An comhlacht, 3) Seoladh, 4) comhad teicniúil, 5) Déantóir an innill a thuariscítear thíos, 6) Dearbhaíonn sé go bhfuil an t-inneall, 7) Go gclóinn sé le na teoracha seo a leanas agus a trasuimh isteach i ndlí náisiúnta, 8) Le haghaidh innill an agusín IV, 9) Uimhir teastais, 10) Comhlacht a chuireadh i bhfíois, 15) caighdeáin comhchuíbhithe a úsáidtear, 16) caighdeáin eile nó sonraíochtaí teicniúla a úsáidtear, 17) Déanta ag, 18) Dáta, 19) Ainm an tsínitheora, 20) Feidhm, 21) Síniú.
- hu :** 1) **CE megfelelő ségi nyilatkozat (eredeti)**, 2) A vállalat, 3) Cím, 4) műszaki dokumentáció, 5) Az alábbi gép gyártója, 6) Kijelenti, hogy a gép, 7) Megfelel az alábbi irányelveknek valamint azok honosított előírásainak, 8) A IV. melléklet gépeihez, 9) Bizonylati szám, 10) Értesített szervezet, 15) felhasznált harmonizált szabványok, 16) egyéb felhasznált műszaki szabványok és előírások hivatkozásai, 17) Kelt (hely), 18) Dátum, 19) Aláíró neve, 20) Funkció, 21) Aláírás.
- is :** 1) **Samræmisvottorð ESB (upprunalega)**, 2) Fyrirtækið, 3) Aðsetur, 4) Tæknilegar skrá, 5) Smíður tækisins sem lýst er hér á eftir, 6) Staðfestir að tækið, 7) Samræmist eftirfarandi stöðlum og staðfærslu þeirra með hljóðn af þjóðarrétti, 8) Fyrir tækin í aukakafla IV, 9) Staðfestingarnúmer, 10) Tilkynnt til, 15) samhæfða staðla sem notaðir, 16) önnur staðlar eða forskriftir notað, 17) Staður, 18) Dagsetning, 19) Nafn undirritaðs, 20) Staða, 21) Undirskrift.
- it :** 1) **Dichiarazione CE di conformità (originale)**, 2) La società, 3) Indirizzo, 4) fascicolo tecnico, 5) Costruttore della macchina descritta di seguito, 6) Dichiaro che questa macchina, 7) È conforme alle direttive seguenti e alle relative trasposizioni nel diritto nazionale, 8) Per le macchine Allegato IV, 9) Numero di Attestazione, 10) Organismo notificato, 15) norme armonizzate applicate, 16) altre norme e specifiche tecniche applicate, 17) Stabilità a, 18) Data, 19) Nome del firmatario, 20) Funzione, 21) Firma.
- lt :** 1) **CE atitikties deklaracija (originalas)**, 2) Bendrovė, 3) Adresas, 4) Techninė byla, 5) Žemiau nurodytas įrenginio gamintojas, 6) Pareiškia, kad šis įrenginys, 7) Atitinka toliau nurodytas direktyvas ir į nacionalinius teisės aktus perkeltas jų nuostatas, 8) IV priedas dėl mašinu, 9) Sertifiko Nr, 10) Paskelbtoji įstaiga, 15) suderintus standartus naudojamus, 16) Kiti standartai ir techninės specifikacijos, 17) Pasirašyta, 18) Data, 19) Pasirašiusio asmens vardas ir pavardė, 20) Pareigos, 21) Parašas.
- lv :** 1) **EK atbilstības deklarācija (oriģināls)**, 2) Uzņēmums, 3) Adrese, 4) tehniskās lietas, 5) Tālāk aprakstītās iekārtas ražotājs, 6) Apliecinā, ka šī iekārta, 7) Ir atbilstoša tālāk norādītajām direktīvām un to transpozīcijai nacionālajā likumdošanā, 8) Iekārtām IV pielikumā, 9) Apliecināš numurs, 10) Reģistrētā organizācija, 15) lietotajiem saskaņotajiem standartiem, 16) lietotajiem tehniskajiem standartiem un specifikācijām, 17) Sastādīts, 18) Datums, 19) Parakstītāja vārds, 20) Amats, 21) Paraksts.
- mt :** 1) **Dikjarazzjoni ta' Konformità KE (originali)**, 2) Il-kumpanija, 3) Indirizz, 4) fajl tekniku, 5) Manifattriċi tal-magna deskritta hawn isfel, 6) Tididkjarja li din il-magna, 7) Hija konformi hija konformi mad-Direttivi segwenti u l-ligijiet li jimplementawhom fil-ligi nazzjonali, 8) Ghall-magni fl-Anness IV, 9) Numru taċ-certifikat, 10) Entità nnotifikata, 15) l-istandards armonizzati użati, 16) standards tekniċi u specifikazzjonijiet oħra użati, 17) Magħmul f, 18) Data, 19) lsem il-firmatarju, 20) Kariga, 21) Firma.
- nl :** 1) **EG-verklaring van overeenstemming (oorspronkelijke)**, 2) Het bedrijf, 3) Adres, 4) technisch dossier, 5) Constructeur van de hierna genoemde machine, 6) Verklaart dat deze machine, 7) In overeenstemming is met de volgende richtlijnen en hun omzettingen in het nationale recht, 8) Voor machines van bijlage IV, 9) Goedkeuringsnummer, 10) Aangezegde instelling, 15) gehanteerde geharmoniseerde normen, 16) andere gehanteerde technische normen en specificaties, 17) Opgemaakt te, 18) Datum, 19) Naam van ondergetekende, 20) Functie, 21) Handtekening.
- no :** 1) **CE-samsvarserklæring (original)**, 2) Selskapet, 3) Adresse, 4) tekniske arkiv, 5) Fabrikant av følgende maskin, 6) Erklærer at denne maskinen, 7) Oppfyller kravene i følgende direktiver, med nasjonale gjennomføringsbestemmelser, 8) For maskinene i tillegg IV, 9) Attestnummer, 10) Notifisert organ, 15) harmoniserte standarder som brukes, 16) Andre standarder og spesifikasjoner brukt, 17) Utstedt i, 18) Dato, 19) Underskriverens navn, 20) Stilling, 21) Underskrift.
- pl :** 1) **Deklaracja zgodności CE (oryginalne)**, 2) Spółka, 3) Adres, 4) dokumentacji technicznej, 5) Wykonawca maszyny opisanej poniżej, 6) Oświadca, że ta maszyna, 7) Jest zgodna z następującymi dyrektywami i odpowiadającymi przepisami prawa krajowego, 8) Dla maszyn załącznik IV, 9) Numer certyfikatu, 10) Jednostka certyfikująca, 15) zastosowanych norm zharmonizowanych, 16) innych zastosowanych norm technicznych i specyfikacji, 17) Sporządzono w, 18) Data, 19) Nazwisko podpisującego, 20) Stanowisko, 21) Podpis.
- pt :** 1) **Declaração de conformidade CE (original)**, 2) A empresa, 3) Morada, 4) processo técnico, 5) Fabricante da máquina descrita abaixo, 6) Declara que esta máquina, 7) Está em conformidade às directivas seguintes e às suas transposições para o direito nacional, 8) Para as máquinas no anexo IV, 9) Número de certificado, 10) Entidade notificada, 15) normas harmonizadas utilizadas, 16) outras normas e especificações técnicas utilizadas, 17) Elaborado em, 18) Data, 19) Nome do signatário, 20) Cargo, 21) Assinatura.
- ro :** 1) **Declarație de conformitate CE (originală)**, 2) Societatea, 3) Adresa, 4) cârtii tehnice, 5) Constructor al mașinii descrise mai jos, 6) Declară că prezenta mașină, 7) Este conformă cu directivele următoare și cu transpunerea lor în dreptul național, 8) Pentru mașinile din anexa IV, 9) Număr de atestare, 10) Organism notificat, 15) standardele armonizate utilizate, 16) alte standarde și specificații tehnice utilizate, 17) Întocmit la, 18) Data, 19) Numele persoanei care semnează, 20) Funcția, 21) Semnătura.
- sk :** 1) **ES vyhlásenie o zhode (pôvodný)**, 2) Názov spoločnosti, 3) Adresa, 4) technické dokumentácie, 5) Výrobca nižšie opísaného stroja, 6) Vyhlasuje, že tento stroj, 7) Je v súlade s nasledujúcimi smernicami a smernicami transponovanými do vnútroštátneho práva, 8) Pre stroje v prílohe IV, 9) Číslo certifikátu, 10) Notifikačný orgán, 15) použité harmonizované normy, 16) použité iné technické normy a predpisy, 17) Miesto vydania, 18) Dátum vydania, 19) Meno podpisujúceho, 20) Funkcia, 21) Podpis.
- sl :** 1) **ES Izjava o ustreznosti (izvirna)**, 2) Družba, 3) Naslov, 4) tehnične dokumentacije, 5) Proizvajalac tukaj opisanega stroja, 6) Izjavlja, da je ta stroj, 7) Ustreza naslednjim direktivam in njihovim transpozicij v državno pravo, 8) Za stroje priloga IV, 9) Številka potrdila, 10) Obvestilo organu, 15) uporabljene harmonizirane standarde, 16) druge uporabljene tehnične standarde in zahteve, 17) V, 18) Datum, 19) Ime podpisnika, 20) Funkcija, 21) Podpis.
- sv :** 1) **CE-försäkran om överensstämmelse (original)**, 2) Företaget, 3) Adress, 4) tekniska dokumentationen, 5) Konstruktor av nedan beskrivna maskin, 6) Försäkrar att denna maskin, 7) Överensstämmer med nedanstående direktiv och införlivandet av dem i nationell rätt, 8) För maskinerna i bilaga IV, 9) Nummer för godkännande, 10) Organism som underrättats, 15) Harmoniserade standarder som använts, 16) andra tekniska standarder och specifikationer som använts, 17) Upprättat i, 18) Datum, 19) Namn på den som undertecknat, 20) Befattning, 21) Namnteckning.

UKCA DECLARATION OF CONFORMITY (ME 315 48V S3 / ME 316 48V S3 / ME 318 48V S3 / ME 320 48V S3)

This document is a specimen of the UKCA declaration of conformity mirroring the content of the original declaration provided with the machine.

This specimen and the original document may contain data fields which does not apply to the machine. These fields are left blank if not relevant.

See the original certificates for all relevant values for your machine.

UKCA DECLARATION OF CONFORMITY

Manufacturer: **MANITOU BF**
Address: **430, RUE DE L'AUBINIÈRE - BP 10249
44158 ANCENIS CEDEX - FRANCE**
Authorized representative: **MANITOU UK
Ebbleke Industrial Estate - Dorset BH 31 6BB
Verwood - United Kingdom**

The manufacturer declares that the below described machinery:

**ME 315 48V S3
ME 316 48V S3
ME 318 48V S3
ME 320 48V S3**

Complies with the following legislation:

The supply of Machinery (Safety) Regulations 2008, as amended

The machine is designed for the lifting of persons:

Applied procedure: Non applicable
Certificate number: Non applicable
Dated:
Approved body: Non applicable

**Noise Emission in the Environment by Equipment
for use Outdoors Regulations 2001, as amended**

Applied procedure:
Approved body:

Sound power level:

Measured: dB (A)
Guaranteed: dB (A)

Electromagnetic Compatibility Regulations 2016, as amended

The following designated standards have been addressed:

EN 12895

The following standards or technical guidance have been addressed:

-

At: _____ Date: _____
Name of signatory:
Position:
Company:
Signature:

SAFETY PLATES AND STICKERS

⚠ IMPORTANT ⚠

*Clean all of the stickers and safety plates to make them legible.
It is essential to replace stickers and safety plates which are illegible or damaged.
Check the presence of stickers and safety plates after replacing any spare parts.*

PLATES AND STICKERS

REF	PART NO.	DESCRIPTION
1		- Ignition switch
2	52548660	- Parking brake
3	52548603	- Fuse instruction
4		- Fuses
5	52759172	- Warning risk of misuse (for UK only)
6	828054	- Trapping safety instruction
7	52521861	- Mast safety instruction
8	Consult your dealer	- Manufacturer's plate
9	828044	- Fork safety instruction
10	52521805	- Slings instruction
11	24653	- Slings point
12	52531617	- Driver safety instruction
13	52548638	- Emergency stop button
14	Consult your dealer	- Load chart (according to model) *
15	52521860	- Hydraulic oil
16	289101	- Tie-down point

* The load chart referred to in the notice is a standard or blank chart. Each lift truck which can be used with an attachment has a specific chart. To obtain this, consult your dealer.

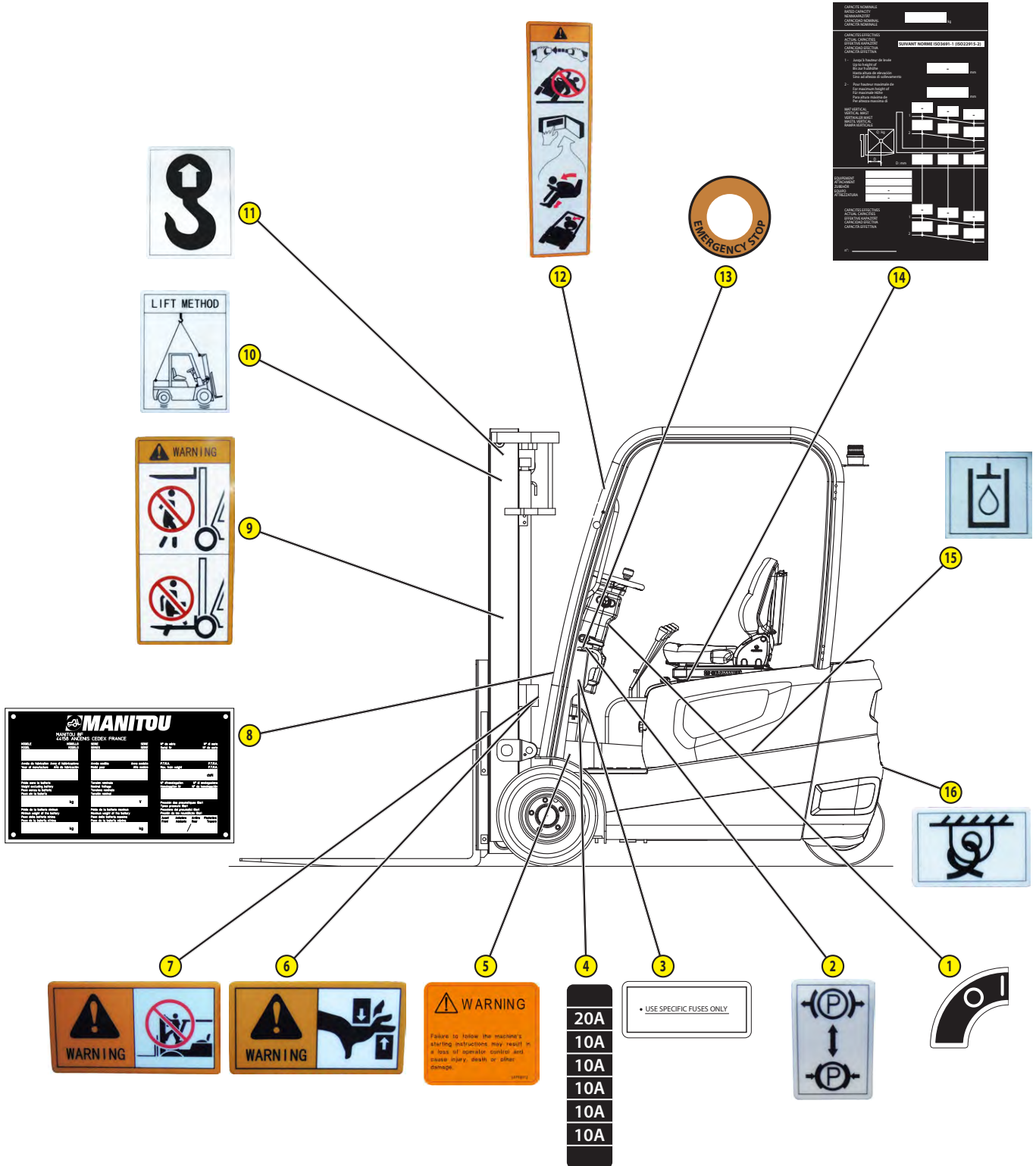

IDENTIFICATION OF THE LIFT TRUCK

As our policy is to promote a constant improvement of our products, our range of telescopic lift trucks may undergo certain modifications, without obligation for us to advise our customers.

When you order parts, or when you require any technical information, always specify:

NOTE: For the owner's convenience, it is recommended that a note of these numbers is made in the spaces provided, at the time of the delivery of the lift truck.

LIFT TRUCK MANUFACTURER'S PLATE

- A - MODEL
- B - SERIES
- C - Serial No.
- D - Year of manufacture
- E - Model year
- F - Authorized gross vehicle weight
- G - Weight without battery
- H - Rated voltage
- I - Homologation No.
- J - Min. battery weight
- K - Max. battery weight
- L - Tire pressures

For any further technical information regarding your lift truck refer to chapter: 2 - DESCRIPTION: CHARACTERISTICS.

HYDRAULIC PUMP MOTOR

- Type
- Model
- Part number
- Power
- Serial No.

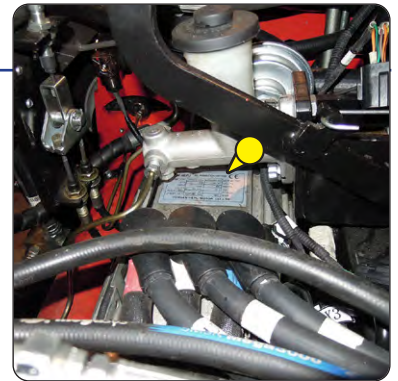

REAR WHEEL TRANSMISSION MOTORS

- Type
- Serial No.
- Part number
- Model
- Power



REAR WHEEL TRANSMISSION

- Type
- Serial No.
- Part number



MAST

- Mast identification No.



FRAME

- Frame No.



ATTACHMENT MANUFACTURER'S PLATE

- A - Model
- B - Serial No.
- C - Year of manufacture
- D - Unladen weight
- E - Centre of gravity
- F - Rated capacity
- G - Working pressure

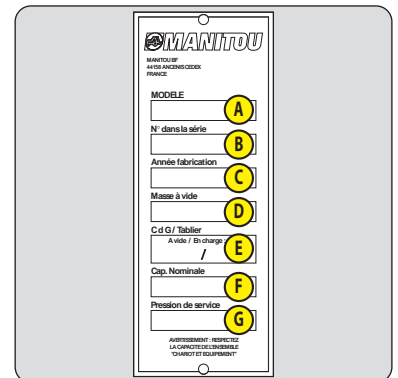

CHARACTERISTICS

DESIGNATION	1.1	MANUFACTURER	MANITOU					
	1.2	MODEL TYPE	ME315 ME315 FOB	ME316 ME316 FOB	ME318 ME318 FOB	ME320 ME320 FOB		
1.3	Propulsion: battery, diesel, petrol, LPG, mains		Battery					
1.4	Type of operation: manual, pedestrian, standing, seated		Seated					
1.5	Rated capacity/load on forks (basic capacity)	Q (t)	1.5	1.6	1.8	2		
1.6	Center of gravity of load	c (mm)	500					
1.8	Distance from the load bearing surface to the centre of the front axle	x (mm)	360					
1.9	Wheelbase	y (mm)	1250	1358	1358	1465		
WEIGHT	2.1	Weight of truck in working order	kg	2860	3120	3240	3470	
	2.2	Front axle load laden	kg	3600	4100	4350	4750	
	2.2.1	Rear axle load laden	kg	560	620	690	720	
	2.3	Front axle load unladen	kg	1350	1440	1440	1530	
	2.3.1	Rear axle load unladen	kg	1510	1680	1800	1940	
RUNNING CARRIAGE	3.1	Tire equipment: bandage (V), super-elastic (SE), pneumatic (L)		SE				
	3.2	Size of front wheels	" or mm	18 x 7 - 8	18 x 7 - 8	18 x 7 - 8	200/50-10	
	3.3	Size of rear wheels	" or mm	15 x 4.5 / 8	15 x 4.5 / 8	15 x 4.5 / 8	15 x 4.5 / 8	
	3.5	Number of front wheels (x = drive wheel)		2x				
	3.5.1	Number of rear wheels (x = drive wheel)		2 twinned				
	3.6	Front wheel gage (middle of wheels)	b10 (mm)	910				
	3.7	Rear wheel gage (middle of wheels)	b11 (mm)	175				
DIMENSIONS	4.1	Tilt of mast forward	α (°)	5.5				
	4.1.1	Tilt of mast backward	β (°)	6.5				
	4.2	Height of mast lowered	h1 (mm)	1995				
	4.3	Free lift	h2 (mm)	145				
	4.4	Lift height	h3 (mm)	3000				
	4.5	Overall height with mast extended (with/without load back rest)	h4 (mm)	3945 / 3565				
	4.7	Height of driver protection (cab)	h6 (mm)	2040				
	4.8	Height of seat	h7 (mm)	1000				
	4.12	Height of towing coupling	h10 (mm)	500				
	4.19	Total length	l1 (mm)	2860	2968	2968	3076	
	4.20	Length of forks at heel	l2 (mm)	1790	1898	1898	2006	
	4.21	Overall width	b1 (mm)	1086	1086	1086	1120	
	4.22	Section of fork arms	e / s (mm)	100 / 35	100 / 35	100 / 35	122 / 40	
	4.22.2	Length of fork arms	l (mm)	1070				
	4.23	Fork carriage to DIN 15173 A/B		FEM 2A				
	4.24	Width of fork carriage	b3 (mm)	1000				
	4.31	Ground clearance of mast	m1 (mm)	100				
	4.32	Ground clearance at centre of wheel-base	m2 (mm)	110				
	PERFORMANCES	5.1	Speed of travel laden	km/h	16	16	16	15
		5.1.1	Speed of travel unladen	km/h	16	16	16	15
5.2		Rate of lift (laden)	m/s	0.4	0.4	0.4	0.4	
5.2.1		Rate of lift (unladen)	m/s	0.47	0.47	0.45	0.45	
5.3		Speed of lowering laden	m/s	0.46	0.46	0.46	0.47	
5.3.1		Speed of lowering unladen	m/s	0.45	0.44	0.42	0.42	
5.5		Nominal towing power laden	N	7000	7500	8000	9000	
5.5.1		Nominal towing power unladen	N	7250	7720	8300	9300	
5.7		Slope laden	%	16	16	15	13	
5.7.1		Slope unladen	%	18	18	17	15	
5.9	Acceleration time laden	s	4.5	4.7	4.8	4.9		
5.9.1	Acceleration time unladen	s	4.1	4.3	4.4	4.5		
5.10	Service brake		Multidisc oil-immersed brake					

ENGINE SPECIFICATION	6.1	Drive motor power rating	kW		2 x 4,75			
	6.2	Lift motor power	kW		8.6			
	6.3	Size of battery tray as per DIN 43 531/35/36 A,B,C, no			DIN 43531 A			
	6.4	Battery voltage/capacity	V / Ah	48 / 575	48 / 575	48 / 575	48 / 690	
	6.6	Energy consumption according to VDI cycle	kWh / h	4.3	4.3	4.3	4.7	
	MISCELLANEOUS	8.1	Speed control			Electronic		
8.2		Working hydraulic pressure for attachments	Bar	155	180	180	180	
8.3		Oil flow rate for attachments	L / min	35				
8.4		Sound level, at driver's ears according to EN 12053	dB (A)	70				
8.5		Traction controller			Kollmorgen AC			
8.6		Hydraulic movement controller			Kollmorgen AC			
8.7		Average weighted acceleration on driver's body (according to standard NF EN 13059)		0.5	0.5	0.5	0.8	

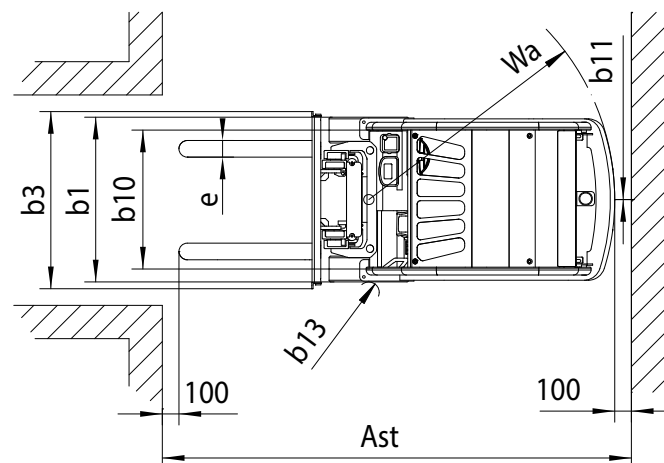
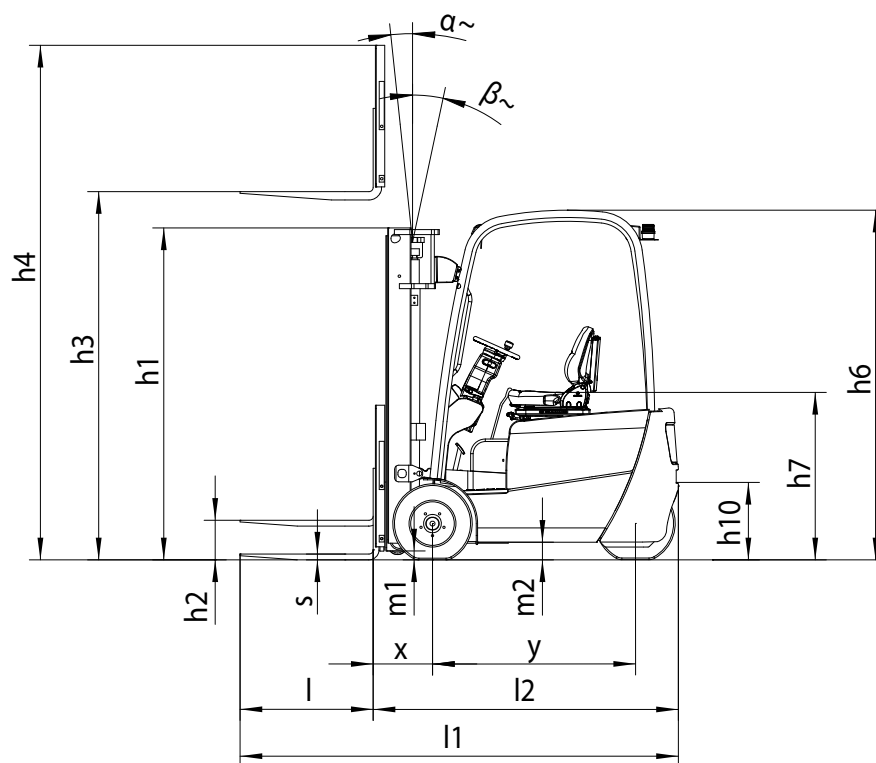

MAST CHARACTERISTICS AND LOAD CHARTS

NOTE: The specifications given are not binding on the manufacturer and can be modified without prior notification.

LIFTING MAST	FREE LIFT		HEIGHT OF MAST			TILTING		VALUES ON FORKS				VALUES WITH INTEGRATED TDL								
	h2 with back rest (mm)	h2 without back rest (mm)	h1 lowered (mm)	h4 extended with back rest (mm)	h4 extended without back rest (mm)	α FRONT (°)	β REAR (°)	Height at max. capacity (mm)		Capacity at max. height CoG at 500mm (kg)		Height at max. capacity (mm)		Capacity at max. height CoG at 500mm (kg)						
								1,5t	1,6t	1,8t	2t	1,5t	1,6t	1,8t	2t	1,5t	1,6t	1,8t	2t	
ME 315	145	1845	3265	5.5°	6°	2700	2700	2700	2700	2700	2700	2700	2700	2700	2700	2700	2700	2700	2700	2000
ME 315 FOB	145	1995	3565	5.5°	6°	3000	3000	3000	3000	3000	3000	3000	3000	3000	3000	3000	3000	3000	3000	2000
ME 316	145	2145	3865	5.5°	6°	3300	3300	3300	3300	3300	3300	3300	3300	3300	3300	3300	3300	3300	3300	2000
ME 316 FOB	145	2295	4165	5.5°	6°	3600	3600	3600	3600	3600	3600	3600	3600	3600	3600	3600	3600	3600	3600	2000
ME 318	145	2545	4565	3.5°	5°	4000	4000	4000	4000	4000	4000	4000	4000	4000	4000	4000	4000	4000	4000	2000
ME 318 FOB	145	2710	4865	3.5°	5°	1500 to 4000	1500 to 4000	1800 to 4000	2000 to 4000	1800 to 4000	1700	1950	1800 to 4000	4300	1800 to 4000	2000 to 4000	1450	1600	1700	1950
ME 320	145	2820	5065	3.5°	5°	1500 to 4000	1500 to 4000	1800 to 4000	2000 to 4000	1800 to 4000	1700	1900	1800 to 4000	4500	1800 to 4000	2000 to 4000	1400	1500	1700	1900
ME 320 FOB	145	2840	5245	3.5°	5°	1500 to 4000	1500 to 4000	1800 to 4000	2000 to 4000	1800 to 4000	1700	1800	1800 to 4000	4700	1800 to 4000	2000 to 4000	1350	1500	1600	1800
DUPLIX TOTAL VISIBILITY	900	1260	1845	3.5°	5°	2700	2700	2700	2700	2700	2700	2700	2700	2700	2700	2700	2700	2700	2700	2000
	1050	1410	1995	3.5°	5°	3000	3000	3000	3000	3000	3000	3000	3000	3000	3000	3000	3000	3000	3000	2000
	1200	1560	2145	3.5°	5°	3300	3300	3300	3300	3300	3300	3300	3300	3300	3300	3300	3300	3300	3300	2000
	1350	1710	2295	3.5°	5°	3600	3600	3600	3600	3600	3600	3600	3600	3600	3600	3600	3600	3600	3600	2000
	1600	1960	2545	3.5°	5°	4000	4000	4000	4000	4000	4000	4000	4000	4000	4000	4000	4000	4000	4000	2000
DUPLIX FREE LIFT	965	1325	1910	3.5°	5°	4000	4000	4000	4000	4000	4000	4000	4000	4000	4000	4000	4000	4000	4000	1950
	1065	1425	2010	3.5°	5°	1400 to 4000	1600 to 4000	1700 to 4000	1950 to 4000	1400 to 4000	1650 to 4000	1950 to 4000	1600 to 4000	1600 to 4000	1650 to 4000	1950 to 4000	1350	1550	1600	1900
	1130	1490	2075	3.5°	5°	1400 to 4000	1600 to 4000	1700 to 4000	1900 to 4000	1400 to 4000	1600 to 4000	1900 to 4000	1400 to 4000	1600 to 4000	1650 to 4000	1900 to 4000	1350	1500	1600	1800
	1230	1590	2175	3.5°	5°	1400 to 4000	1600 to 4000	1700 to 4000	1900 to 4000	1400 to 4000	1600 to 4000	1900 to 4000	1400 to 4000	1600 to 4000	1650 to 4000	1900 to 4000	1300	1450	1600	1700
	1295	1655	2240	3.5°	5°	1400 to 4000	1600 to 4000	1650 to 4000	1900 to 4000	1400 to 4000	1500	1600	1650 to 4000	1600 to 4000	1650 to 4000	1900 to 4000	1250	1400	1500	1600
TRIPLEX FREE LIFT	1465	1825	2410	3.5°	5°	1400 to 4000	1600 to 4000	1650 to 4000	1900 to 4000	1400 to 4000	1500	1400	1650 to 4000	1600 to 4000	1650 to 4000	1900 to 4000	1150	1250	1300	1400
	1680	2010	2625	3.5°	5°	1400 to 4000	1600 to 4000	1600 to 4000	1900 to 4000	1400 to 4000	1100	1200	1600 to 4000	1600 to 4000	1600 to 4000	1900 to 4000	1000	1100	1200	1300
	1895	2010	2840	3.5°	5°	1400 to 4000	1500 to 4000	1550 to 4000	1800 to 4000	800	900	1000	1500 to 4000	1550 to 4000	1800 to 4000	800	900	1000	1100	

BATTERY CHARACTERISTICS

	COMPARTMENT DIMENSIONS (MM)					BATTERY TYPE	BATTERY CAPACITY	WEIGHT OF BATTERY + COMPARTMENT	
	A	B	C	H1	H2				
ME 315 ME 315 FOB	830	522	165	612	627	EXIDE FULMEN	STANDARD	48V-160A-460Ah	710 kg
							HIGH CAPACITY	48V-160A-500Ah	716 kg
						HOPPECKE	STANDARD	48V-160A-460Ah	728 kg
							HIGH CAPACITY	48V-160A-500Ah	747 kg
						HAWKER	STANDARD	48V-160A-460Ah	717 kg
							HIGH CAPACITY	48V-160A-500Ah	717 kg
ME 316 ME 316 FOB ME 318 ME 318 FOB	830	630	202	612	627	EXIDE FULMEN	STANDARD	48V-160A-575Ah	844 kg
							HIGH CAPACITY	48V-160A-625Ah	873 kg
						HOPPECKE	STANDARD	48V-160A-575Ah	879 kg
							HIGH CAPACITY	48V-160A-625Ah	908 kg
						HAWKER	STANDARD	48V-160A-575Ah	854 kg
							HIGH CAPACITY	48V-160A-625Ah	873 kg
ME 320 ME 320 FOB	830	738	238	612	627	EXIDE FULMEN	STANDARD	48V-160A-690Ah	1000 kg
							HIGH CAPACITY	48V-160A-750Ah	1031 kg
						HOPPECKE	STANDARD	48V-160A-690Ah	1037 kg
							HIGH CAPACITY	48V-160A-750Ah	1068 kg
						HAWKER	STANDARD	48V-160A-690Ah	980 kg
							HIGH CAPACITY	48V-160A-750Ah	1040 kg



FRONT AND REAR TIRES

FRONT		PRESSURE (bar) LOAD PER TIRE (kg)	ME 315 ME 315 FOB	ME 316 ME 316 FOB	ME 318 ME 318 FOB	ME 320 ME 320 FOB
ADVANCE	18 X 7 - 8	PRESSURE	SOLID	SOLID	SOLID	
		unladen	700	700	700	
		laden	1800	2050	2200	
	200/50 - 10	PRESSURE				SOLID
		unladen				750
		laden				2400
CONTINENTAL	18 X 7 - 8 Non marking	PRESSURE	SOLID	SOLID	SOLID	
		unladen	700	700	700	
		laden	1800	2050	2200	
	200/50 - 10 Non marking	PRESSURE				SOLID
		unladen				750
		laden				2400

REAR		PRESSURE (bar) LOAD PER TIRE (kg)	ME 315 ME 315 FOB	ME 316 ME 316 FOB	ME 318 ME 318 FOB	ME 320 ME 320 FOB
ADVANCE	15 X 4 ^{1/2} - 8	PRESSURE	SOLID	SOLID	SOLID	SOLID
		unladen	750	850	900	950
		laden	300	300	350	350
CONTINENTAL	15 X 4 ^{1/2} - 8 Non marking	PRESSURE	SOLID	SOLID	SOLID	SOLID
		unladen	750	850	900	950
		laden	300	300	350	350

		PRESSURE (bar)	LOAD (kg)	GROUND CONTACT PRESSURE (kg/cm ²)		GROUND CONTACT AREA (cm ²)		
				HARD GROUND	SOFT GROUND	HARD GROUND	SOFT GROUND	
ADVANCE	18 X 7 - 8	SOLID	700					
			1800					
			2050					
			2200					
	200/50 - 10	SOLID	750					
			2400					
	15 X 4 ^{1/2} - 8	SOLID	300					
			350					
			750					
			850					
			900					
			950					
	CONTINENTAL	18 X 7 - 8 Non marking	SOLID	700				
				1800				
				2050				
2200								
200/50 - 10 Non marking		SOLID	750					
			2400					
15 X 4 ^{1/2} - 8 Non marking		SOLID	300					
			350					
			750					
			850					
			900					
			950					

INSTRUMENTS AND CONTROLS

DESCRIPTION

- 1 - DRIVER'S SEAT
- 2 - SEAT BELT
- 3 - STEERING WHEEL TILTING KNOB
- 4 - DRIVING SEAT ACCESS HANDLE
- 5 - REAR-VIEW MIRROR
- 6 - SWITCHES
- 7 - HORN
- 8 - DASHBOARD
- 9 - LIGHT AND INDICATOR SWITCH
- 10 - IGNITION SWITCH
- 11 - FORWARD/REVERSE SHUTTLE
- 12 - ACCELERATOR PEDAL
- 13 - SERVICE BRAKE PEDAL
- 14 - PARKING BRAKE
- 15 - HYDRAULIC CONTROLS
- 16 - EMERGENCY STOP BUTTON
- 17 - LOAD CHART
- 18 - DOCUMENT CLIP
- 19 - DOCUMENT HOLDER
- 20 - LIFT BATTERY COVER
- 21 - POWER FUSES (NOT ILLUSTRATED)
- 22 - FUSES (NOT ILLUSTRATED)
- 23 - BATTERY PLUG
- 24 - LOCKING THE BATTERY TRAY
- 25 - BRAKE OIL TANK (NOT ILLUSTRATED)
- 26 - FRONT SIDELIGHTS AND WORKING LIGHTS
- 27 - FRONT INDICATOR LIGHTS
- 28 - REAR LIGHTS
- 29 - FLASHING LIGHT
- 30 - WORKING TAIL LIGHT
- 31 - MINI LEVERS HYDRAULIC CONTROLS (OPTION) (NOT ILLUSTRATED)

NOTE: All the terms such as: RIGHT, LEFT, FRONT, REAR are as seen by an observer seated on driver's seat and looking straight ahead.

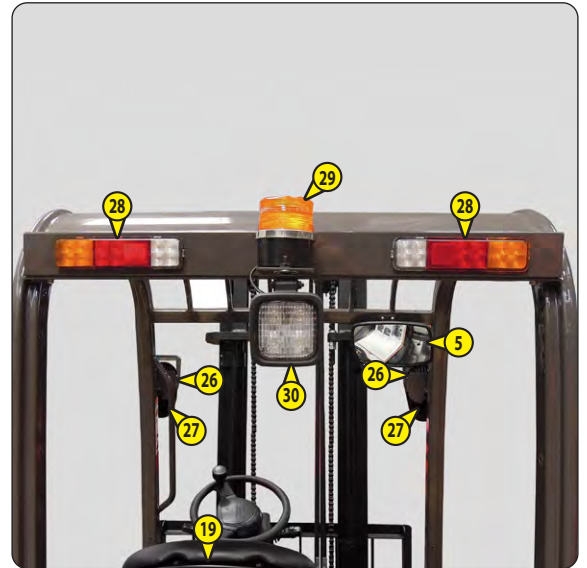
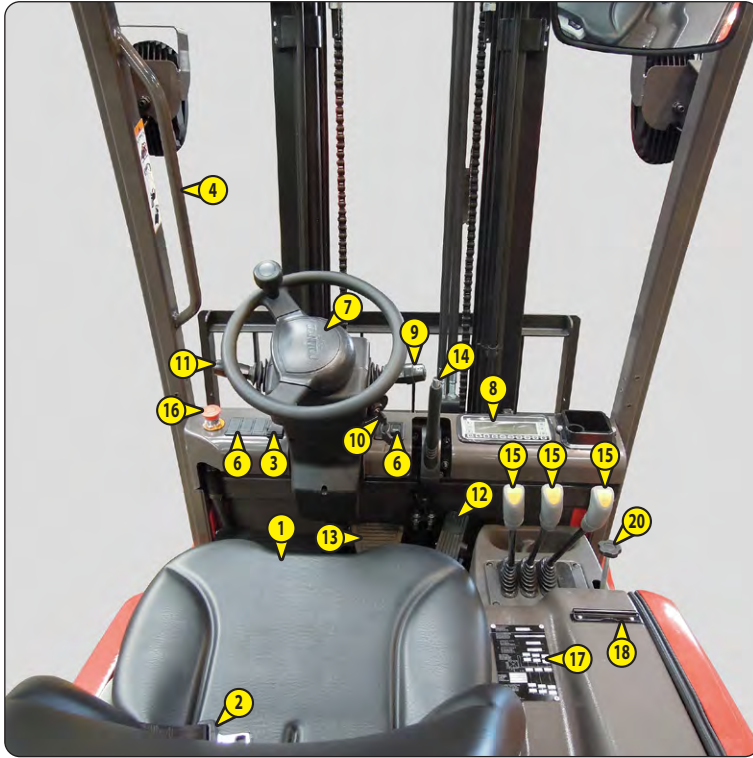

1 - DRIVER'S SEAT

DESIGNED FOR MAXIMUM COMFORT, THIS SEAT CAN BE ADJUSTED AS FOLLOWS.

WEIGHT ADJUSTMENT (FIG. A)

Adjust the weight when the driver is sitting on the seat.

- Pull the weight adjustment lever 1 fully out.
- Move the weight adjustment lever 1 up to increase the weight or down to reduce it.
- There are ten possible positions between the min and max weights. Before each run, return the lever to the central position. The max. or min. position is indicated by a freely traveling lever.
- The driver's weight is correctly adjusted when the arrow is in the center of indicator 2.
- After completing weight adjustment, fully lower the lever 1.

NOTE: To avoid any health problems, it is recommended to check and adjust the weight setting before starting the lift truck.

LONGITUDINAL ADJUSTMENT (FIG. B)

- Adjust the locking lever until you reach the position required. This then locks and the seat will not shift into another position.



Only operate the lever by its recessed section and do not grasp from below, at the risk of crushing the hand.

LUMBAR ADJUSTMENT (FIG. C) ME 315 / ME 316 / ME 318 / ME 320

This increases the comfort of the seat and the driver's freedom of movement.

- Turn knob to 1 to adjust the height and depth of the lumbar support of the upper part of the back-rest.
- Turn knob to 2 to adjust the height and depth of the lumbar support of the lower part of the back-rest.

ANGLE ADJUSTMENT OF THE BACK-REST (FIG. D) ME 315 / ME 316 / ME 318 / ME 320

- Support the back-rest, pull the lever and position the back-rest to find the desired position.



If you do not support the back rest when making adjustments, it will swing forwards.

MAINTENANCE

Dirt may adversely affect the correct functioning of the seat. For this reason, make sure your seat is always clean.

- The cushions do not require to be removed from the seat frame for cleaning.



A moving backrest increases the risk of an accident!

First check the resistance of the fabric on a small concealed area before using any fabric and plastic cleaner.

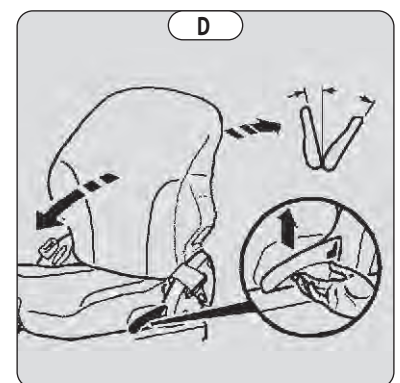
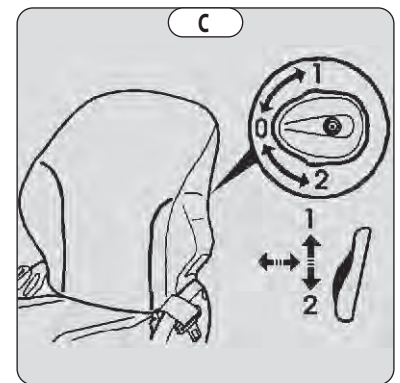
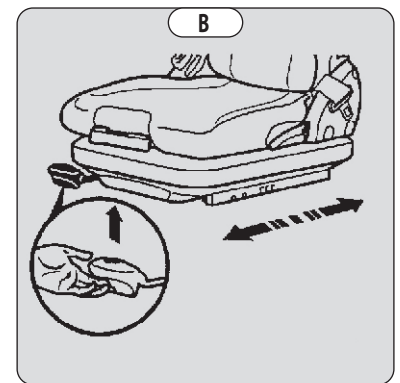
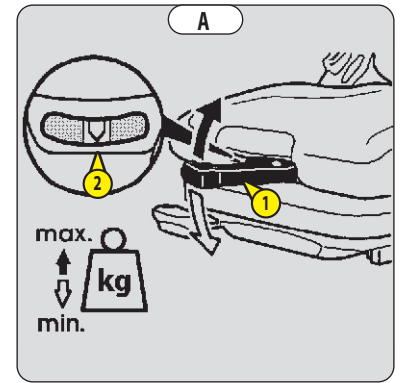

2 - SEAT BELT

⚠ IMPORTANT ⚠

*In no event should the lift truck be used if the seat belt is defective (fixing, locking, cuts, tears, etc.).
Repair or replace the seat belt immediately.*

- Sit correctly on the seat.
- Check that seat belt is not twisted.
- Place the seat belt at hip level.
- Attach the seat belt and check that it locks.
- Adjust the seat belt to your body shape without compressing your pelvis and without excessive slack.

3 - STEERING WHEEL TILTING KNOB

This handle enables the angle of the steering wheel to be adjusted.

- Turn the handle 1 towards A to loosen and adjust steering wheel.
- Turn the handle 1 towards B to lock steering wheel in the required position.



4 - DRIVING SEAT ACCESS HANDLE

5 - REAR-VIEW MIRROR

6 - SWITCHES

NOTE: The location of the switches may vary depending on the options or the display version.

- A - OPTION
- B - OPTION
- C - OPTION
- D - FLASHING LIGHT
- E - OPTION
- F - REAR WORKING LIGHT



7 - HORN

- Press the center of the steering wheel to operate the horn.



8 - DASHBOARD

DISPLAY 1st VERSION

When the lift truck is switched on the control screen displays MANITOU.



The main menu will then appear.

The operator can only access keys 1, 2 and 3.

NOTE: All the other keys of the control panel are reserved for the dealer.



BATTERY STATE OF CHARGE

0.0 Km/h

TRAVEL SPEED



DRIVING SPEED LIMITER

Press this button  to select fast or slow speed mode. Lamp D will light when slow speed mode is selected.



DRIVING POWER LIMITER

Press the button  to select high or low power mode. Lamp E will light when the low power mode is selected.



PARKING BRAKE

This indicator lamp comes on when the parking brake is applied.

To access the detailed menu:

Press the button  to access the detailed menu. The display of the different parameters will appear on the screen:

Travel speed (Km/h).

DRIVE SPEED 0.0Km/h

Total running time (h).

TOTAL TIME 0 h

Total travel running time (h).

T.ACS TIME 0 h

Total handling running time (h).

P.ACS TIME 0 h



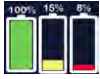

BATTERY CAPACITY INDICATOR (A)

Shows the remaining battery capacity :

- Green colour if remaining battery capacity is above 20%.
- Yellow colour if remaining battery capacity is comprised between 11% and 20%.
- Red colour if remaining battery capacity is less than or equal to 10%, and an audio warning is set off. When the battery capacity drops to 10%, the lift truck functions will be limited : very low travel speed and no hydraulic movements.



FORWARD / BACKWARD INDICATOR (B)

Travelling forward, the symbol shows an upward arrow.
Travelling backward, the symbol shows a down arrow.



TRAVEL SPEED INDICATOR (C)

Drive speed is shown when the lift truck is running.



WORKING MODE INDICATOR (D)

There are 3 modes. The selected mode appears in green.

- S** : Safe mode, travel speed is limited when steering.
- P** : Power mode, no speed limitation when steering.
- E** : Eco mode, travel speed is limited at 50% and when steering.



WHEEL ANGLE INDICATOR (E)

Shows the steering position.



TOTAL TIME INDICATOR (F)

Shows accumulated working hours, up to 9999.



HYDRAULIC MOVEMENTS CUT-OFF INDICATOR (G)

When the hydraulic movement cut-off button (4) is pressed, the indicator lights up and the hydraulic movements are cut, except for the steering.



NEUTRAL POSITION INDICATOR (H)

This indicator is visible when the neutral position is applied.



LOW BATTERY INDICATOR (I)

This indicator is visible when remaining battery capacity is less or equal to 20%.



LIFTING SPEED LIMITATION INDICATOR (J)

This indicator is visible and lifting speed is cut-off by 50% when remaining battery level is less than or equal to 10%.



OPERATOR PRESENCE INDICATOR (K)

When the operator leaves his seat over 2 seconds, this indicator is visible, the machine stops and an audio warning is set on.

ME 315 48V S3, ME 316 48V S3, ME 318 48V S3, ME 320 48V S3 from 2023-04-15 :

When the operator has unfastened his seatbelt and leaves his seat, the machine stops and an audio warning is set on.



PARKING BRAKE INDICATOR (L)

This indicator is visible when the parking brake is applied.

ME 315 48V S3, ME 316 48V S3, ME 318 48V S3, ME 320 48V S3 from 2023-04-15 :



TÉMOIN CEINTURE DE SÉCURITÉ (M)

This indicator is visible when the seatbelt is not fastened, and if the parking brake is released then an audio warning is set on.

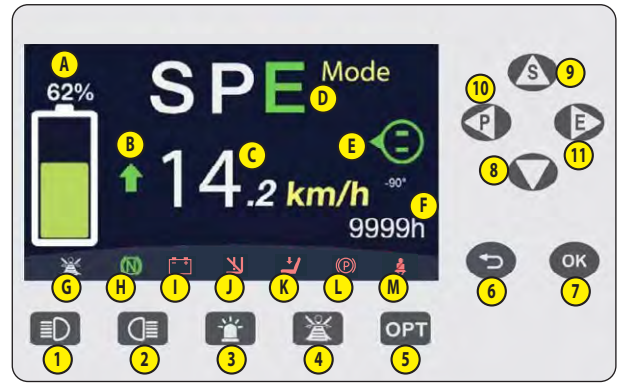

CONTROL BUTTONS

FRONT ADDITIONAL LIGHTS BUTTON (1)

Press this button to turn on/off the front additional lights. This function is disabled if the display requires a password.

WORKING TAIL LIGHT BUTTON (2)

Press this button to turn on/off the working tail light. This function is disabled if the display requires a password.

FLASHING LIGHT BUTTON (3)

Press this button to turn on/off the flashing light. This function is disabled if the display requires a password.

HYDRAULIC MOVEMENT CUT-OFF BUTTON (4)

Press this button to cut-off/on mast movements and hydraulic movements, except for the steering.

NOTE : Only for mini lever. This function don't cut mechanical hydraulic controls.

OPT OPT RESERVED BUTTON (5)

Press this button to cut-off/on option. This function is disabled if the display requires a password.

CANCEL OR BACK BUTTON (6)

Functions depend of the interface:

- Back.
- Delete.
- Cancel.

OK CONFIRM BUTTON (7)

Functions depend of the menu:

- Enter the submenu.
- Confirm modification.

DOWN BUTTON (8)

Functions depend of the menu:

- Move cursor down.
- Decrease number by one.

UP/“S MODE” BUTTON (9)

Functions depend of the menu:

- Change the mode to S.
- Move cursor up.
- Increase number by one.

LEFT/“P MODE” BUTTON (10)

Functions depend of the menu:

- Change the mode to P.
- Move cursor left.

RIGHT/“E MODE” BUTTON (11)

Functions depend of the menu:

- Change the mode to E.
- Move cursor right.

DISPLAY INFORMATION

Press the up and down arrows simultaneously from the home screen.
To exit this menu, press again up and down arrows simultaneously.

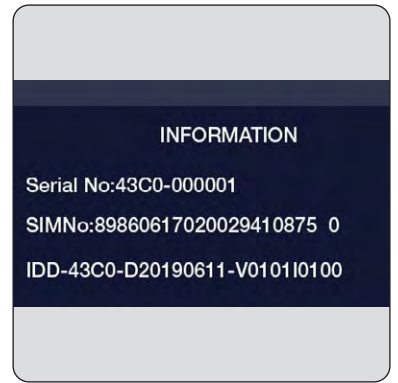

SECRET CODE

The secret code allows for a different level of access to machine data.

From the home screen, press to enter the code, then press again.

In case of an invalid entry, press .

Operator code by default : .

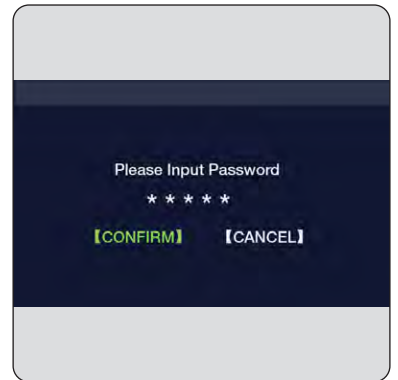

OPERATOR MENU

The operator menu allows access to the machine settings (read-only).

To navigate in the menu use the arrows buttons as a directional pad. Press to access a sub-menu or validate a value.

Press to return to the previous screen.



MENU SW MONITOR

- SeatSW:** Operator presence indicator state.
- ForwardSW:** Forward/reverse shuttle state (forward).
- ReverseSW:** Forward/reverse shuttle state (reverse).
- PedalBrakeSW:** Brake light state.
- AccPedalSW:** Acceleration/deceleration state.
- ParkingSW:** Parking brake state.
- P.ModeSW:** Power working mode state.
- S.ModeSW:** Safe working mode state.
- TiltSW:** Mast tilt lever position state.
- SideSW:** Tipping lever position state.
- LiftSW:** Fork lift lever position state.
- SpareSW:** Standby state.
- AttachementSW:** Carriage position lateral shift state.



MENU OPERATOR MONITOR

KeyOnHour: Operating time in hours.

T.EnableHour: Transmission operating time in hours.

P.EnableHour: Hydraulic pump operating time in hours.

SteerPotVal: Steering angle sensor value.

AccelPotVal: Accelerator pedal sensor value.

LiftPotVal: Lift pump analog sampling value.

T.M.Speed: Traction motor speed in rpm.

P.M.Speed: Hydraulic pump speed.

L.M.Speed: Left motor speed.

T.RmsCur: Effective value of the traction motor current in rms.

P.RmsCur: Effective value of the pump motor current in rms.

LeftRmsCur: Effective value of the left drive wheel current in rms.

OPERATE MONITOR			
KeyOnHour	5	T.M.Speed	0
T.EnableHour	5	P.M.Speed	0
P.EnableHour	0	L.M.Speed	0
SteerPotVal	90	T.RmsCur	5
AccelPotVal	217	P.RmsCur	0
LiftPotVal	763	LeftRmsCur	0

MENU TEMP MONITOR

T.M.Temp: Right motor temperature in °C.

T.ACS.Temp: Transmission controller temperature in °C.

P.M.Temp: Hydraulic pump motor temperature in °C.

P.ACS.Temp: Hydraulic pump controller temperature in °C.

LeftM.Temp: Left motor transmission temperature in °C.

LeftACS.Temp: Controller left motor temperature in °C.

TEMP MONITOR	
T.M.Temp	27
T.ACS.Temp	20
P.M.Temp	25
P.ACS.Temp	19
LeftM.Temp	0
LeftACS.Temp	0

MENU SET

LanguageSet: Choose language.

BrightnessAdjust: Brightness adjustment.

Versions:

- IDD = Dashboard software version.
- T.C = Motor transmission controller software version.
- P.C = Motor pump controller software version.
- L.C = Motor transmission controller software version.
- V.C Version = Minilevers software version .

SpeedUnits: Speed units selection.

SET	
LanguageSet	
BrightnessAdjust	
Version	
SpeedUnits	

DEFAULT CODE

If this message appears, please contact your dealer.

FAULT CODE: 161 Communication fault
--

9 - LIGHT AND INDICATOR SWITCH

The switch controls the visual signals.

- A - The lights are off.
- B - The sidelights and the rear lights are on.
- C - The front working lights and rear lights are on.
- D - The right hand indicator light flash.
- E - The left hand indicator light flash.

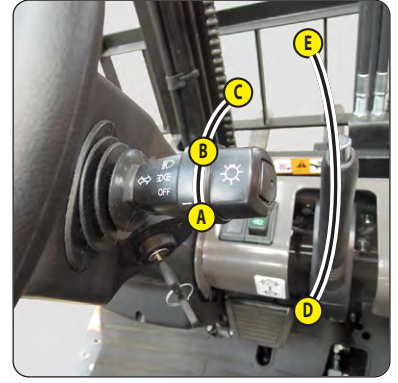

10 - IGNITION SWITCH

This switch has 2 positions:

- A - Ignition off.
- B - Ignition on.

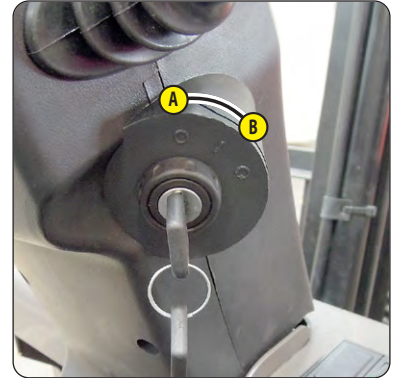

11 - FORWARD/REVERSE SHUTTLE

When changing the direction of travel, the lift truck should be traveling at slow speed and not accelerating.

- FORWARD: Push the lever forwards into position A.
- REVERSE: Pull the lever backwards into position B.
- NEUTRAL: To start the lift truck, the lever must be in the neutral position C.

NOTE: Reverse lights and a reversing sound alarm indicate that the lift truck is traveling in reverse.

SAFETY FOR MOVING THE LIFT TRUCK

The operator must observe the following sequence to move the truck forwards or backwards:

- 1 - sit down correctly in the driver's seat and fasten the seatbelt,
- 2 - switch on the ignition,
- 3 - release the parking brake,
- 4 - engage forward or reverse movement.

To stop the forklift truck, the following sequence must be observed:

- 1 - set the forward/reverse selector to neutral,
- 2 - engage the parking brake,
- 3 - switch off the ignition,
- 4 - unfasten the seatbelt and get out of the lift truck.

If these sequences are not followed you must then return the reversing gear to the neutral position and repeat the sequence.

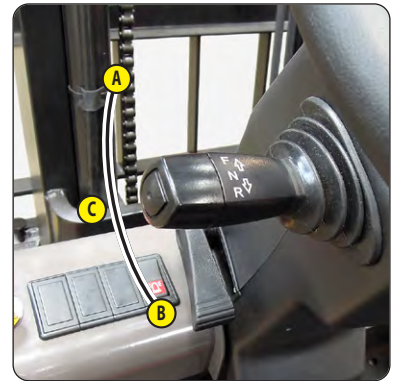

12 - ACCELERATOR PEDAL

13 - SERVICE BRAKE PEDAL

14 - PARKING BRAKE

To apply the parking brake, depress the service brake pedal and pull the lever backwards into position A.

To release the parking brake, press button 1 and push the lever forwards to position B.

NOTE: If the parking brake is released when the driver is not present an intermittent audible signal is sounded.

ME 315 48V S3, ME 316 48V S3, ME 318 48V S3, ME 320 48V S3 from 2023-04-15 :

If the parking brake is released when the operator unfasten the seatbelt, the machine stops and an audio warning is set on.

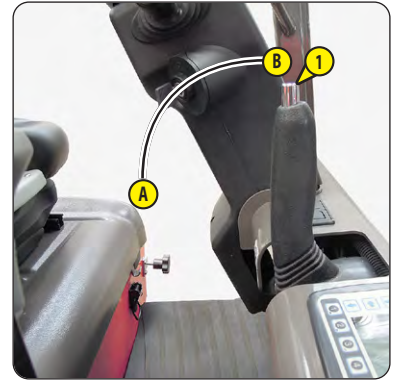

15 - HYDRAULIC CONTROLS

⚠ IMPORTANT ⚠

*Do not attempt to alter the hydraulic system pressure. In the event of suspected malfunction, contact your dealer.
ANY ALTERATION MAY RENDER THE WARRANTY NULL AND VOID.*

Use the hydraulic controls carefully without jerking, to avoid accidents caused by shaking the lift truck.

Using the hydraulic controls is only possible if the driver is present and correctly sat on his seat.

LIFTING THE LOAD

- The lever A backwards for lifting.
- The lever A forwards for lowering.

TILTING THE MAST

- The lever B backward for backward tilting.
- The lever B forwards for forward tilting.

CARRIAGE SIDE-SHIFT

- The lever C backwards for moving sideways to the right.
- The lever C forwards for moving sideways to the left.



16 - EMERGENCY STOP BUTTON

⚠ IMPORTANT ⚠

Be ready for hydraulic movements suddenly stopping when you press this button.

In case of danger, switches off the electrical power supply circuit.

- Pull the button to disable it before restarting the lift truck.



17 - LOAD CHART

Comply with the load chart limits for the lift truck for the attachment used.

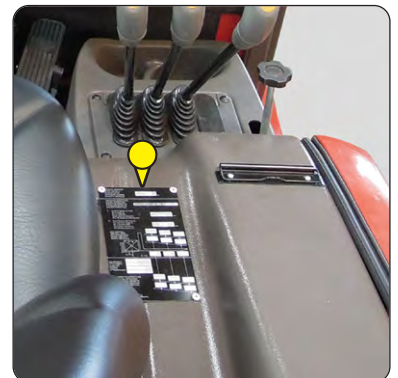

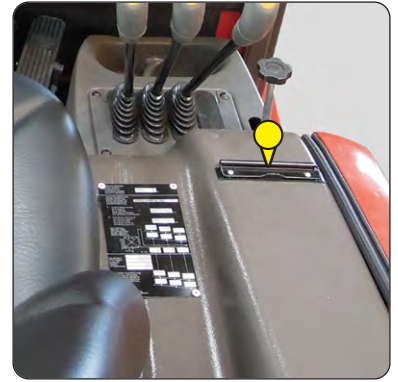

19 - DOCUMENT HOLDER

Make sure that the operator's manual is in the right place, i.e. in the waterproof document holder.



20 - LIFT BATTERY COVER

⚠ IMPORTANT ⚠

For your safety, set down the forks or the attachment on the ground to avoid any incident due to inadvertent operation of the hydraulic controls, and press the emergency stop button.

Beware of the risks of pinching or crushing during this operation. Always lift or hold the battery cover with the handle 2. Check that nothing and nobody interferes with the lowering of the battery cover.

LIFTING THE BATTERY COVER

NOTE: If necessary, tilt the steering wheel forward and the seat backward to lift the battery cover.

- Pull lever upwards and push back 1 to return the hydraulic controls in place.
- Release the latch 2.
- Place one hand under the driver's seat and gently lift the battery cover.
- Check that the stay 3 is blocked.

LOWERING THE BATTERY COVER

- Place one hand under the driver's seat and hold the battery cover.
- Release the stay 3 and gently lower the battery cover back down.
- Lock the battery cover with the latch 2.
- Pull the lever 1 upwards and push back to return the hydraulic controls to place.

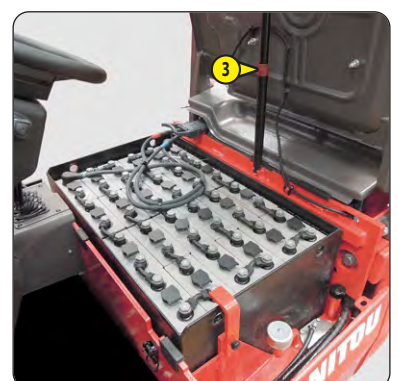
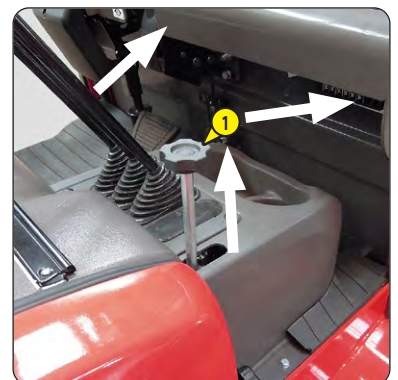

21 - POWER FUSES

- FP1 - Front left-hand wheel motor (250 A).
- FP2 - Front right-hand wheel motor (250 A).
- FP3 - Hydraulic control motor (300A).

NOTE: Replace a used fuse with a new fuse of the same quality and capacity. Never reuse a repaired fuse.

⚠ IMPORTANT ⚠

In case of technical faults, consult your dealer.



22 - FUSES

- Remove the casing 1 to access the fuses.
- F1 - Control circuit (10 A).
- F2 - Main circuit (10 A).
- F3 - Lighting (10 A).
- F4 - Option (10 A).
- F5 - Option (10 A).
- F6 - Option (20 A).

NOTE: Replace a used fuse with a new fuse of the same quality and capacity. Never reuse a repaired fuse.

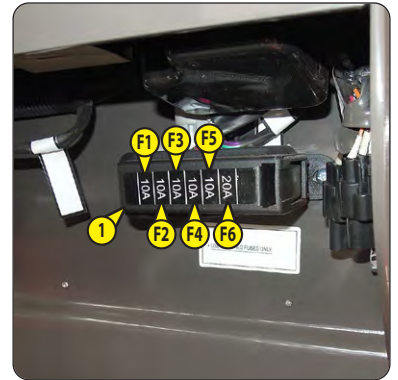

23 - BATTERY PLUG

Disconnects or connects the electrical circuit power supply.

- Raise the battery cover (see: 2 - DESCRIPTION: INSTRUMENTS AND CONTROLS).

⚠ IMPORTANT ⚠

*The lift truck's ignition must be switched off before connecting or disconnecting battery plug 1.
Disconnect the battery in the event of a fault or when working on the lift truck.*

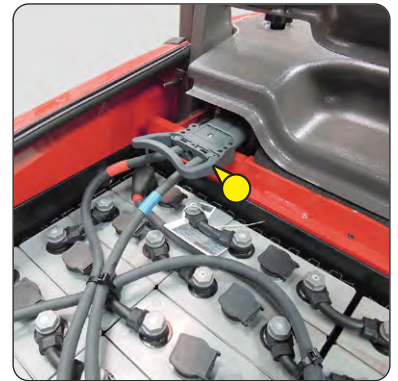

24 - LOCKING THE BATTERY TRAY

See: 3 - MAINTENANCE: F - OCCASIONAL MAINTENANCE.



25 - BRAKE OIL TANK

See: 3 - MAINTENANCE: B - EVERY 50 HOURS OF SERVICE.



26 - FRONT SIDELIGHTS AND WORKING LIGHTS

- A - Front left sidelight.
- Front left working light.
- B - Front right sidelight.
- Front right working light.



27 - FRONT INDICATOR LIGHTS

- C - Front left indicator light.
- D - Front right indicator light.

28 - REAR LIGHTS

- A - Rear left headlight.
Rear left brake light.
- B - Rear left indicator light.
- C - Rear left reverse light.
- D - Rear right headlight.
Rear right brake light.
- E - Rear right indicator light.
- F - Rear right reverse light.

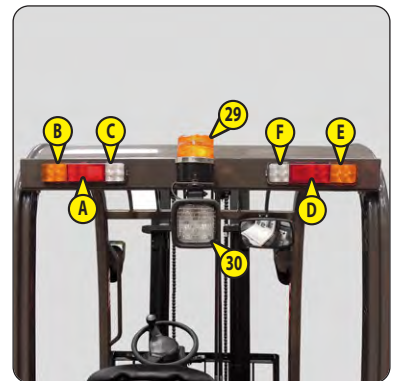

29 - FLASHING LIGHT.

30 - WORKING TAIL LIGHT

31 - MINI LEVERS HYDRAULIC CONTROLS (OPTION)

⚠ IMPORTANT ⚠

Do not attempt to alter the hydraulic system pressure by interfering with the pressure regulating valve. In the event of suspected malfunction, contact your dealer. ANY ALTERATION MAY RENDER THE WARRANTY NULL AND VOID.

Use the hydraulic controls carefully without jerking, to avoid accidents caused by shaking the lift truck.

Using the hydraulic controls is only possible if the driver is present and correctly sat on his seat.

LIFTING THE LOAD

- The mini-lever A backwards when lifting.
- The mini-lever A forwards when lowering.

TILTING THE MAST

- The mini-lever B backward for backward tilting.
- The mini-lever B forwards for forward tilting.

CARRIAGE SIDE-SHIFT

- The mini-lever C backwards to move sideways to the right.
- The mini-lever C forwards to move sideways to the left.

ATTACHMENT (OPTION)

- The mini-lever C forwards or backwards.

FORWARD/NEUTRAL/REVERSE GEAR SELECTION

When operating this control, the lift truck should be travelling at slow speed and not accelerating.

- FORWARD: Push the knob forward E1.
- REVERSE: Pull the knob backwards E2.
- NEUTRAL: The knob must be in the intermediate position to start the lift truck E3.

NOTE: The reversing lights and the acoustic reversing alarm indicate that the lift truck is running in reverse.

SAFETY FOR MOVING THE LIFT TRUCK

The operator must observe the following sequence to move the truck forwards or backwards:

- 1 - sit down correctly in the driver's seat and fasten the seatbelt,
- 2 - switch on the ignition,
- 3 - release the parking brake,
- 4 - engage forward or reverse movement.

To stop the forklift truck, the following sequence must be observed:

- 1 - set the forward/reverse selector to neutral,
- 2 - engage the parking brake,
- 3 - switch off the ignition,
- 4 - unfasten the seatbelt and get out of the lift truck.

If these sequences are not followed you must then return the reversing gear to the neutral position and repeat the sequence.

EMERGENCY STOP BUTTON

⚠ IMPORTANT ⚠

Be ready for hydraulic movements suddenly stopping when you press this button.

In case of danger, switches off the electrical power supply circuit.

- Pull the button F to disable it before restarting the lift truck.

HORN

- Press the red button G to operate the horn.

ADJUSTING THE ARMREST

The armrest is adjustable in height and length.

- Press the button H to adjust in height.
- Press the button I to adjust in length.

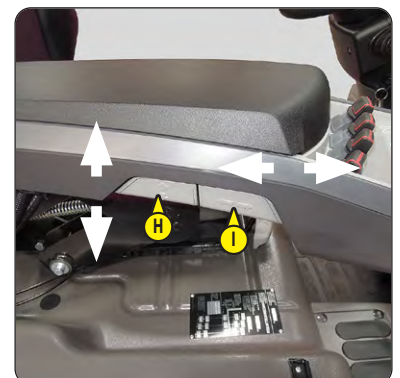
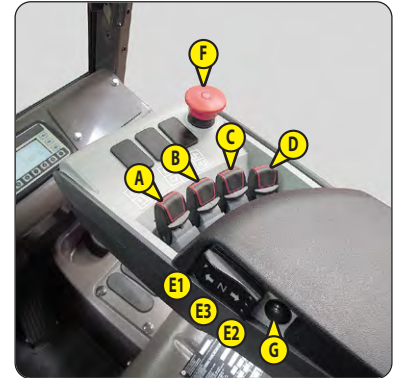

3 - MAINTENANCE

TABLE OF CONTENTS

3 - MAINTENANCE

<i>ORIGINAL MANITOU SPARE PARTS AND EQUIPMENT</i>	4
<i>FILTERS AND CARTRIDGES</i>	5
<i>LUBRICANTS</i>	6
<i>SERVICING SCHEDULE</i>	8
<i>A - DAILY OR EVERY 10 HOURS OF SERVICE</i>	10
<i>B - EVERY 50 HOURS OF SERVICE</i>	12
<i>C - EVERY 250 HOURS OF SERVICE</i>	16
<i>D - EVERY 500 HOURS OF SERVICE</i>	18
<i>E - EVERY 1000 HOURS OF SERVICE</i>	20
<i>F - OCCASIONAL MAINTENANCE</i>	22

ORIGINAL MANITOU SPARE PARTS AND EQUIPMENT

OUR LIFT TRUCKS MUST BE SERVICED USING ORIGINAL MANITOU PARTS.

BY ALLOWING THE USE OF NON ORIGINAL MANITOU PARTS, YOU RISK:

⚠ IMPORTANT ⚠

THE USE OF COUNTERFEIT PARTS OR COMPONENTS NOT APPROVED BY THE MANUFACTURER, WILL CAUSE YOU TO LOSE THE BENEFIT OF THE CONTRACTUAL GUARANTEE.

- Legally - to be held responsible in the event of an accident.
- Technically - to cause operating malfunctions or shorten the life of the lift truck

BY USING ORIGINAL MANITOU PARTS FOR MAINTENANCE OPERATIONS, YOU BENEFIT FROM OUR KNOW-HOW

Through its network, MANITOU provides the user with,

- Know-how and competence.
- The guarantee of high-quality work.
- Original replacement parts.
- Help with preventive maintenance.
- Efficient help with diagnosis.
- Improvements due to experience feedback.
- Operator training.
- Only the MANITOU network has detailed knowledge of the design of the lift truck and therefore the best technical ability to provide maintenance.

⚠ IMPORTANT ⚠

ORIGINAL REPLACEMENT PARTS ARE DISTRIBUTED ONLY BY MANITOU AND THE DEALER NETWORK.

The list of dealers is available on the MANITOU website www.manitou.com

FILTERS AND CARTRIDGES

HYDRAULIC SYSTEM

HYDRAULIC RETURN OIL FILTER CARTRIDGE

- Part no.: 824074
- Change: 1000 H

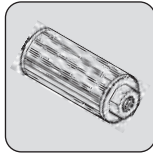

SUCTION STRAINER FOR HYDRAULIC OIL TANK

- Part no.: 824459
- Clean: 1000 H



BREATHER FOR THE HYDRAULIC OIL TANK

- Part number: 897045
- Change: 1000 H

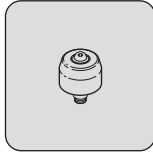

LUBRICANTS

⚠ IMPORTANT ⚠

USE THE RECOMMENDED LUBRICANTS:

- For topping up, oils may not be miscible.

- For oil changes, MANITOU oils are perfectly appropriate.

DIAGNOSTIC ANALYSIS OF OILS

If a service or maintenance contract has been organized with the dealer, a diagnostic analysis of engine, transmission and axle oils may be requested depending on the rate of use.

RECOMMENDED LUBRICANT

TRANSMISSION		RECOMMENDED LUBRICANT									
PARTS TO BE LUBRICATED	CAPACITY	-40°C	-30	-20	-10	0	+10	+20	+30	+40	+50°C
		FRONT WHEEL REDUCING GEAR	0.35 Liter								

MAST		RECOMMENDED LUBRICANT									
PARTS TO BE LUBRICATED	CAPACITY	-40°C	-30	-20	-10	0	+10	+20	+30	+40	+50°C
		MAST LIFTING CHAINS									
GREASING OF THE MAST											MANITOU BLACK MULTI-PURPOSE LUBRICANT

HYDRAULIC SYSTEM		RECOMMENDED LUBRICANT									
PARTS TO BE LUBRICATED	CAPACITY	-40°C	-30	-20	-10	0	+10	+20	+30	+40	+50°C
		HYDRAULIC OIL TANK ME 315 48V S3 / ME 315 48V S3 FOB / ME 316 48V S3 / ME 316 48V S3 FOB ME 318 48V S3 / ME 318 48V S3 FOB / ME 320 48V S3 / ME 320 48V S3 FOB	25 Liters 30 Liters							ISO VG 100	
								ISO VG 68			
								ISO VG 46			
								ISO VG 37			
								MANITOU ISO VG 32 HYDRAULIC OIL			

BRAKING SYSTEM		RECOMMENDED LUBRICANT									
PARTS TO BE LUBRICATED	CAPACITY										
BRAKE CIRCUIT	1.5 Liters	MANITOU DOT 4 BRAKE FLUID									

PACKAGING

OIL	PRODUCT	PACKAGING / PART NO.					
		1 LITER	2 LITERS	5 LITERS	20 LITERS	55 LITERS	209 LITERS
	- MANITOU TRACTELF SF3 MECHANICAL TRANSMISSION OIL			545976	582391	947918	894257
	- MANITOU ISO VG 32 HYDRAULIC OIL			744638	744637		744636
	- MANITOU DOT 4 BRAKE FLUID	786653					

GREASE	PRODUCT	PACKAGING / PART NO.					
		400 ML	400 GR	1 KG	5 KG	20 KG	50 KG
	- MANITOU BLACK MULTI-PURPOSE LUBRICANT		947766	161590			499235
	- MANITOU SPECIAL CHAIN LUBRICATION (aerosol)	554271					

SERVICING SCHEDULE

⚠ IMPORTANT ⚠

(1): **COMPULSORY 500 HOUR OR 6 MONTH SERVICE.** This service must be carried out after approximately the first 500 hours of operation or within the 6 months following the start-up of the machine (whichever occurs first).

(2): Consult your dealer.

A = ADJUST, C = CHECK, D = RECHARGE, G = GREASE, N = CLEAN, P = BLEED, R = REPLACE, V = DRAIN	PAGE	(1)	DAILY OR EVERY 10 HOURS OF SERVICE	EVERY 50 HOURS OF SERVICE	EVERY 250 HOURS OF SERVICE	EVERY 500 HOURS OF SERVICE OR EVERY YEAR	EVERY 1000 HOURS OF SERVICE OR EVERY TWO YEARS	EVERY 2000 HOURS OF SERVICE OR EVERY TWO YEARS	EVERY 4000 HOURS OF SERVICE	OCCASIONAL
ELECTRICITY										
- Battery	3-10	D	D							
- Battery electrolyte level	3-10	C	C							
- Cleaning the battery	3-11	C	C							
- Electrolyte level of all battery cells	3-12	C		C						
- Battery electrolyte specific gravity.	3-12	C		C		C(2)				
- Condition of control panels	3-16	C			C		C(2)			
- Battery insulation resistance	3-18	C				C		C(2)		
- Condition of wiring harness and cables							C(2)			
- Warning indicators								C(2)		
- Lights and signals								C(2)		
- Steering potentiometer								C(2)		
- Remove the battery tray	3-22									XXX
FRONT WHEEL REDUCERS										
- Front wheels reducers oil level	3-16	C			C					
- Front wheel reducer oil	3-20	V					V			
REAR AXLE										
- Wheel bearings							G(2)			
- Rear axle							C(2)			
TIRES										
- Wheel nut tightening	3-13	C		C						
- Condition of wheels and tires							C(2)			
MAST										
- Tension and alignment of the mast lifting chains	3-13	C/A		C/A						
- Mast	3-13	G		G						
- Mast lifting chains	3-18	N/C/G				N/C/G		C(2)		
- Condition of mast unit								C(2)		
- Chain rollers								C(2)		
- Mast guide rollers								C(2)		
- Mast bearing rollers								C(2)		
- Thickness of the mast wearing plates								C(2)		
HYDRAULIC SYSTEM										
- Hydraulic oil level	3-14	C		C						
- Hydraulic oil	3-20						V			
- Breather for the hydraulic oil tank	3-20						R			
- Suction strainer for hydraulic oil tank	3-20						N			
- Hydraulic return oil filter	3-20						R			
- Condition of cylinders (leakage, rods)							C(2)			
- Speeds of hydraulic movements							C(2)			
- Condition of hoses and flexible pipes							C(2)			
- Hydraulic oil tank								N(2)		
- Hydraulic circuit pressures								C(2)		
- Hydraulic circuit outputs								C(2)		
BRAKING										
- Brake oil level	3-14	C		C						
- Parking brake	3-17	C/A			C/A					
- Brake		C(2)				C(2)				
- Brake oil							V(2)			
- Brake system							P(2)			

A = ADJUST, C = CHECK, D = RECHARGE, G = GREASE, N = CLEAN, P = BLEED, R = REPLACE, V = DRAIN	PAGE	(1)	DAILY OR EVERY 10 HOURS OF SERVICE	EVERY 50 HOURS OF SERVICE	EVERY 250 HOURS OF SERVICE	EVERY 500 HOURS OF SERVICE OR EVERY YEAR	EVERY 1000 HOURS OF SERVICE OR EVERY TWO YEARS	EVERY 2000 HOURS OF SERVICE OR EVERY TWO YEARS	EVERY 4000 HOURS OF SERVICE	OCCASIONAL
OVERHEAD GUARD										
- Seat belt	3-21						C			
- Condition of the rear view mirrors							C(2)			
- Structure							C(2)			
FRAME										
- Structure							C(2)			
- Bearings and articulation rings								C(2)		
ATTACHMENTS										
- Fork wear		C(2)				C(2)				
- Attachment carriage							C(2)			
- Condition of attachments							C(2)			
LIFT TRUCK										
- Towing the lift truck	3-22									XXX
- Sling the lift truck	3-22									XXX
- Transport the lift truck on a platform	3-23									XXX

A - DAILY OR EVERY 10 HOURS OF SERVICE

A1 - BATTERY

RECHARGE

⚠ IMPORTANT ⚠

Do not discharge a battery beyond 80% of its capacity and recharge in one operation in a well ventilated space.

The charger must be adjusted to suit the battery. Refer to the charger instruction manual for details of this operation.

NOTE: The battery is charged with the caps closed and the battery cover open.

- Raise the battery cover (see: 2 - DESCRIPTION: INSTRUMENTS AND CONTROLS).
- Disconnect the battery plug 1.
- Connect the battery plug 1 to the charger socket 2.
- Perform a normal, top-up or equalizing charge (see detail below).
- Disconnect the battery plug 1 from the charger socket 2.
- Reconnect the battery plug 1.
- Close the battery cover.

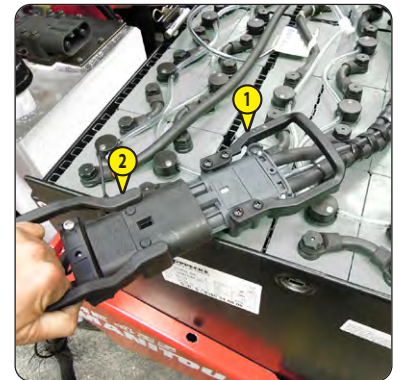

NORMAL CHARGE

If the residual battery capacity after a working cycle is greater than 60 %, it does not need recharging.

- Set the charger to normal and equalization charge mode and switch on.
- The charger will automatically switch off when charging is complete.

TOP-UP CHARGE

When the normal charge is not sufficient to last for an entire working day, and to avoid discharging the battery beyond 80 % of its capacity, a further charge can be added during a meal or rest break.

- Set the charger to normal charge mode only and switch on.
- Once the charge has been topped-up, switch off the charger.

EQUALIZATION CHARGE

Even if the battery has not needed charging for more than one week, the charge must still be equalized once every week.

- Set the charger to charge equalization mode only and switch on.
- The charger will switch off automatically once equalization is completed.

A2 - BATTERY ELECTROLYTE LEVELS

CHECK

⚠ IMPORTANT ⚠

Filling must be carried out after the charging phase.

WITHOUT CENTRAL FILLING

Check the electrolyte level of two or three cells (choose different cells each day).

- Raise the battery cover (see: 2 - DESCRIPTION: INSTRUMENTS AND CONTROLS).
- Disconnect the battery plug 1.
- Open the caps 2 of the selected cells of the battery.
- The electrolyte level must be 15-20 mm above the top of the plates in the battery.
- If necessary, top up with clean distilled or demineralised water that has been stored in a glass container (in case of spillage of water onto the battery see: 3 - MAINTENANCE: A3 - CLEANING THE BATTERY).
- Reclose the caps 2.
- Check the terminal connections and lightly smear with petroleum jelly to prevent the formation of verdigris.
- Reconnect the battery plug 1.
- Close the battery cover.

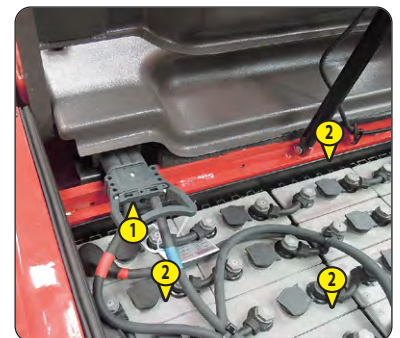

WITH CENTRAL FILLING

- Raise the battery cover (see: 2 - DESCRIPTION: INSTRUMENTS AND CONTROLS).
- Disconnect the battery plug 1.
- The level indicators 3 must be in the up position.
- If necessary, top up with clean distilled or demineralized water.
- Connect the pipe 4 to the pipe of the pump 5.

NOTE: The pump must be situated at a higher level than the battery.

- When the correct level is reached, the vanes 6 automatically stop turning.
- Disconnect the hose 4.
- Check the terminal connections and lightly smear with petroleum jelly to prevent the formation of verdigris.
- Reconnect the battery plug 1.
- Close the battery cover.

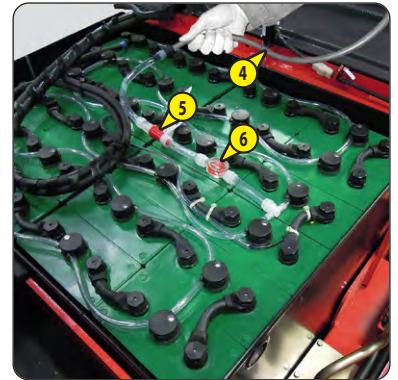
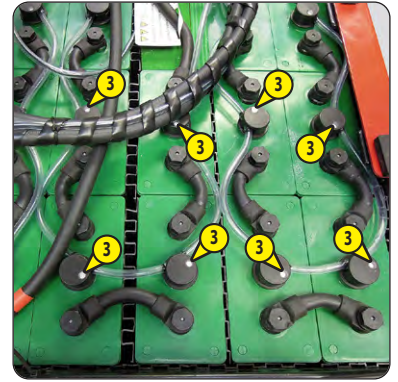

⚠ IMPORTANT ⚠

Handling and servicing a battery can be dangerous, take the following precautions:

- *Wear protective goggles, gloves, an apron and acid-resistant clothing.*
- *Remove rings, watches, bracelets and any clothing incorporating metal.*
 - *Keep the battery horizontal.*
 - *Never smoke or work near a naked flame.*
 - *Work in a well-ventilated area.*
- *Wash your hands each time you work on the battery, as acid is corrosive.*
- *In the event of electrolyte being spilled onto the skin or splashed in the eyes, rinse thoroughly with cold water for 15 minutes and call a doctor.*

A3 – CLEANING THE BATTERY

CHECK

⚠ IMPORTANT ⚠

Disconnect the battery plug and protect before washing.

The battery must be kept clean and dry at all times to avoid self-discharge and leakage currents.

- Raise the battery cover (see: 2 - DESCRIPTION: INSTRUMENTS AND CONTROLS).

WASHING

- Check that the caps are firmly closed.
- Clean the water with soft, non-pressurized water.
- Allow to dry in the open air and wipe the top of the battery with a clean cloth.

NOTE: After washing with water, part of the washing water will have entered the battery tray and must therefore be drained.

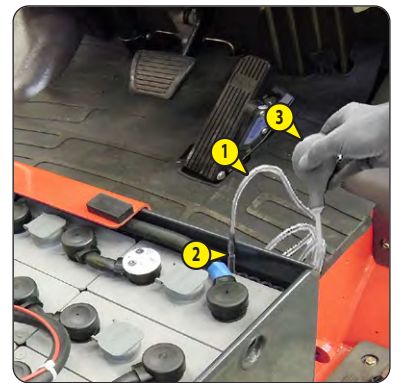

DRAINING THE BATTERY TRAY

- Connect the pipe 1 to the tube 2.
- Fill the bulb 3 and connect it to the other end of the pipe 1.
- Place a container near to the battery. This container must be placed below the bottom of the tray.
- Once the pipe 1 is filled, remove the bulb 3 and place the end of pipe 1 over the container.

⚠ IMPORTANT ⚠

Handling and servicing a battery can be dangerous, take the following precautions:

- *Wear protective goggles, gloves, an apron and acid-resistant clothing.*
- *Remove rings, watches, bracelets and any clothing incorporating metal.*
 - *Keep the battery horizontal.*
 - *Never smoke or work near a naked flame.*
 - *Work in a well-ventilated area.*
- *Wash your hands each time you work on the battery, as acid is corrosive.*
- *In the event of electrolyte being spilled onto the skin or splashed in the eyes, rinse thoroughly with cold water for 15 minutes and call a doctor.*

B - EVERY 50 HOURS OF SERVICE

Carry out the operations described previously as well as the following operations.

B1 – ELECTROLYTE LEVEL IN ALL BATTERY CELLS

CHECK

Perform the same operation as that carried out daily (see: 3 - MAINTENANCE: A2 - battery electrolyte level), but checking all of the cells of the battery.

B2 – BATTERY ELECTROLYTE DENSITY

CHECK

- Raise the battery cover (see: 2 - DESCRIPTION: INSTRUMENTS AND CONTROLS).
- Disconnect the battery plug.
- Measure the temperature of the electrolyte.

NOTE: The electrolyte density varies according to its temperature. It must therefore be measured and converted in accordance with the following rule:

- If $T^{\circ}\text{C} > 30^{\circ}\text{C}$ the correction will be + 0.0007 per $^{\circ}\text{C}$ above this temperature.
- If $T^{\circ}\text{C} < 30^{\circ}\text{C}$ the correction will be - 0.0007 per $^{\circ}\text{C}$ below this temperature.

Example: Density reading 1,285 at 36°C

$$1,285 + (0.0007 \times 6) = 1,289 \text{ kg/dm}^3 \text{ at } 30^{\circ}\text{C}$$

- Measure the electrolyte density in each battery cell using a hydrometer 1.
- Compare the electrolyte reading against the table opposite.
- Do not carry out this check immediately after topping up with distilled water. Recharge the battery for at least one hour before checking the battery electrolyte density.
- Clean and dry the caps (see: 3 - MAINTENANCE: A4 - CLEANING THE BATTERY).
- Check the terminal connections and lightly smear with petroleum jelly to prevent the formation of verdigris.
- Close the battery cover.

⚠ IMPORTANT ⚠

Handling and servicing a battery can be dangerous, take the following precautions:

- Wear protective goggles, gloves, an apron and acid-resistant clothing.
- Remove rings, watches, bracelets and any clothing incorporating metal.
 - Keep the battery horizontal.
 - Never smoke or work near a naked flame.
 - Work in a well-ventilated area.
- Wash your hands each time you work on the battery, as acid is corrosive.

In the event of electrolyte being spilled onto the skin or splashed in the eyes, rinse thoroughly with cold water for 15 minutes and call a doctor.

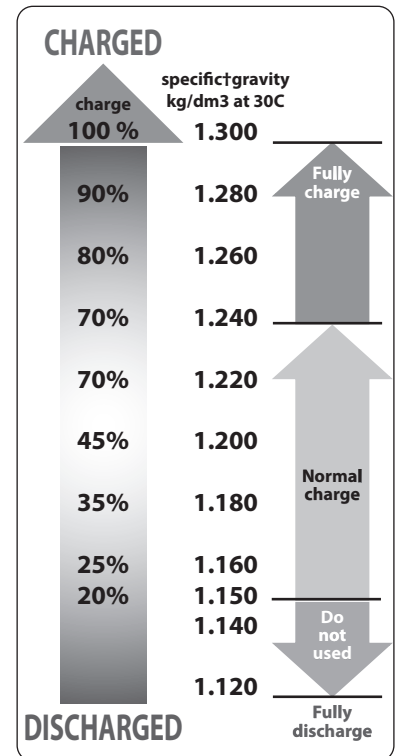
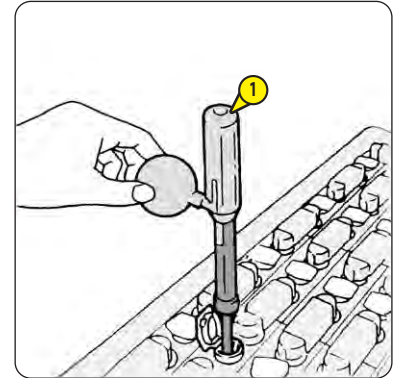

B3 – WHEEL NUT TIGHTENING

CHECK

- Check the condition of the tires, to detect cuts, blisters, wear, etc.
- Check the wheel nut tightening torques. Failure to comply with this instruction may lead to damage and failure of the wheel studs and distortion to the wheels.

Tightening torque of wheel nuts: Front wheels 157 to 176 N.m
Rear wheels 157 to 176 N.m

NOTE: There is an OPTIONAL wheel toolkit.

B4 – TENSION AND ALIGNMENT OF THE MAST LIFTING CHAINS

CHECK - ADJUST

⚠ IMPORTANT ⚠

These checks are important for the good working operation of the mast. In case of technical faults, consult your dealer

Place the lift truck on level ground with the mast in a vertical position and the forks lifted at approximately 200 mm.

- Check the alignment of the mast lifting chains between the carriage chain fasteners and the chain rollers.
- Using your hand verify the chain tension and, if necessary, adjust as follows while ensuring that the carriage is perpendicular to the mast.
- Loosen nut 1.
- Loosen the chain tensioner lock nut 2.
- Adjust the tension by tightening or loosening the nut 3 while checking the alignment of the lifting chains.
- Then tighten lock nut 2 and nut 3.
- Re-tighten the nut 1.



B5 – MAST

GREASE

⚠ IMPORTANT ⚠

In the event of prolonged use in an extremely dusty or oxidizing atmosphere, reduce this interval to 10 working hours or every day.

To be carried out weekly, if the lift truck has been operated for less than 50 hours during the week.

- Remove the carpet and the floor 1.
- Clean and lubricate the following points with grease (see: 3 - MAINTENANCE: LUBRICANTS) and remove the surplus of grease.
 - 2 - Lubricators of the tilt cylinder head axles (2 lubricators).
 - 3 - Lubricators of the tilt cylinder head axles (4 lubricators).
 - 4 - Lubricators of the side-shift carriage (5 lubricators).

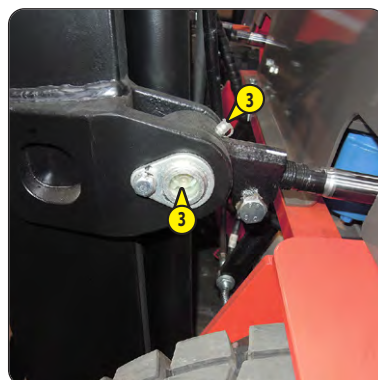
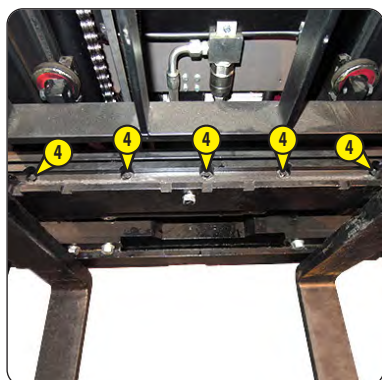
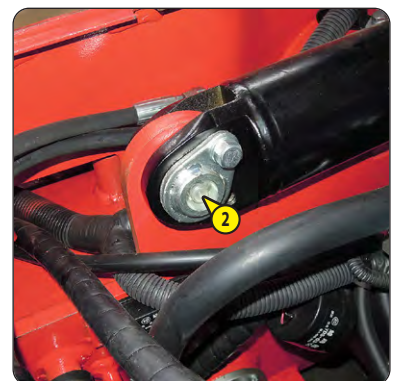

B6 – HYDRAULIC OIL LEVEL

CHECK

⚠ IMPORTANT ⚠

Use a clean funnel and clean the underside of the oil drum before filling.

Place the lift truck on level ground with the mast tilted backward and lowered as far as possible.

- Unscrew the thumb screw 1 and remove the left-hand casing 2.
- Pull out dipstick 3.
- Wipe the dipstick and check the correct level between the MIN and MAX marks.
- If necessary, add oil (see: 3 - MAINTENANCE: LUBRICANTS AND FUEL) via the filler port 4.
- Put back the dipstick 3.
- Visually check that there is no leakage in the tank and pipes.

Always maintain the oil level at maximum as cooling depends on the oil flowing through the tank.



B7 – BRAKE OIL LEVEL

CHECK

⚠ IMPORTANT ⚠

If the brake oil level is abnormal consult your dealer.

Place the lift truck on level ground.

- Remove the carpet and the floor 1.
- Check the oil level in the tank 2. The oil level should be between the min and max marks on the dipstick.
- If necessary, add oil (see: 3 - MAINTENANCE: LUBRICANTS AND FUEL) via the filler port 3.
- Visually check that there is no leakage in the tank and pipes.

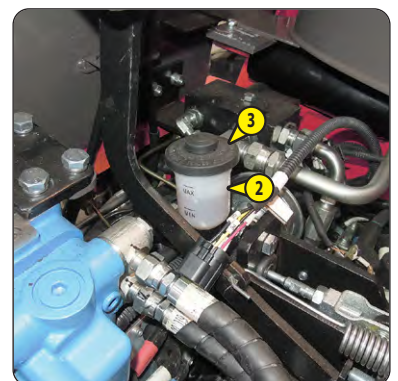

C - EVERY 250 HOURS OF SERVICE

Carry out the operations described previously as well as the following operations.

C1 - CONDITION OF CONTROL PANELS

CHECK

⚠ IMPORTANT ⚠

In case of technical faults, consult your dealer.

- Remove the access panel 1.
- Check the connections and the general condition of the control panels 2 (oxidation, bared wires, etc.).

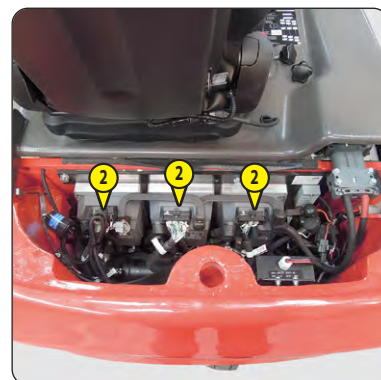

C2 - FRONT WHEELS REDUCERS OIL LEVEL

CHECK

Place the lift truck on level ground.

- Check the level on each front wheel reducer.
- Remove the level plug 1, the oil should be flush with the edge of the hole.
- If necessary, add oil (see: 3 - MAINTENANCE: LUBRICANTS AND FUEL) via the filler port 2.
- Refit and tighten the level plug 1 (tightening torque 22 N.m).
- Visually check for leaks.



C3 – PARKING BRAKE

CHECK - ADJUST

Place the lift truck on a slope of at least 15 % with the rated load in the transport position.

- Check the tightening adjustment by locking the parking brake in position A.
- The adjustment is correct when the lift truck remains stationary on the slope.
- Adjust if necessary.
- Leave the parking brake in position B.
- Progressively tighten the nut 1 and recheck the braking.
- Repeat the operation until the correct braking adjustment is obtained.

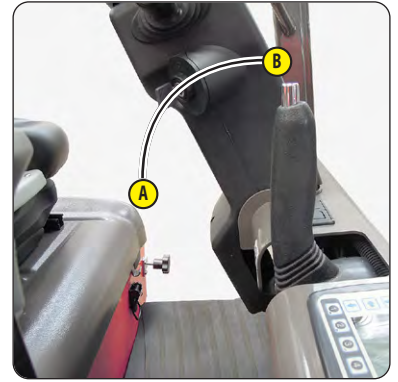

D - EVERY 500 HOURS OF SERVICE

Carry out the operations described previously as well as the following operations.

D1 - BATTERY INSULATION RESISTANCE

CHECK

⚠ IMPORTANT ⚠

In case of technical faults, consult your dealer.

- Raise the battery cover (see: 2 - DESCRIPTION: INSTRUMENTS AND CONTROLS).
- Set the mutimeter 1 to the ohmmeter position.
- Place the multimeter between a terminal of the battery 2 and the battery tray 3, the insulation resistance reading must be at least 1 ohm.

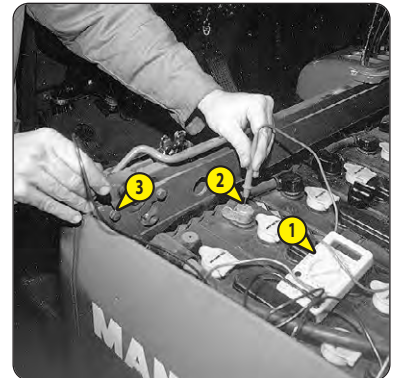

D2 - MAST LIFTING CHAINS

CLEAN - CHECK - GREASE

⚠ IMPORTANT ⚠

In case of technical faults, consult your dealer.

- Wipe the mast lifting chains 1 with a clean, lint-free cloth, then examine them closely so as to detect any signs of wear.
- Vigorously brush the chains to get rid of any foreign matter, with a hard nylon brush and clean diesel fuel.
- Rinse the chains by means of a paint brush impregnated with clean diesel fuel and dry them with a compressed air jet.
- Slightly lubricate the chains (see: 3- MAINTENANCE: LUBRICANTS).

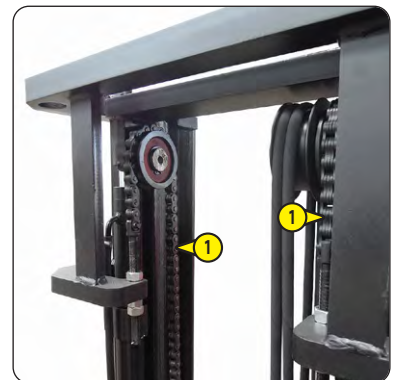

E - EVERY 1000 HOURS OF SERVICE

Carry out the operations described previously as well as the following operations.

E1 - FRONT WHEEL REDUCER OIL

DRAIN

⚠ IMPORTANT ⚠

Dispose of the drain oil in an ecological manner.

Place the lift truck on level ground.

- Place a container under drain plug 1 and unscrew the plug.
- Remove the filling plug 2 to ensure that the oil is drained properly.
- Refit and tighten the drain plug 1 (tightening torque 22 N.m).
- Fill up with oil (see: 3 - MAINTENANCE: LUBRICANTS) through the filler port 2.
- Remove the level plug 3. The level is correct when the oil level is flush with the edge of the port.
- Check for any possible leaks at the drain plug.
- Refit and tighten the filling plug 2 and the level plug 3 (tightening torque 22 N.m).



E2 - HYDRAULIC OIL

DRAIN

E3 - BREATHER FOR THE HYDRAULIC OIL TANK

REPLACE

E4 - SUCTION STRAINER FOR HYDRAULIC OIL TANK

CLEAN

E5 - HYDRAULIC RETURN OIL FILTER

REPLACE

⚠ IMPORTANT ⚠

Before carrying out any work, thoroughly clean the area around the drain plug and the access cover on the hydraulic tank.

Dispose of the drain oil in an ecological manner.

Place the lift truck on level ground with the mast tilted backward and lowered as far as possible.

DRAINING THE OIL

- Unscrew the thumb screw 1 and remove the left-hand casing 2.
- Place a container under drain plug 3 and unscrew the plug.
- Remove the filling plug 4 to ensure that the oil is drained properly.



REPLACING THE BREATHER

- Unscrew the breather 7 and replace it with a new one (see: 3 - MAINTENANCE: FILTERS, CARTRIDGES AND BELTS).

CLEANING THE STRAINER

- Remove and clean the suction strainer 5 using a compressed air jet, check its condition and replace if necessary (see: 3 - MAINTENANCE: FILTERS AND CARTRIDGES).
- Refit the suction strainer 5.

REPLACEMENT OF THE RETURN FILTER

- Unscrew the locking screws of the access panel (8).
- Unscrew the hydraulic return oil filter 9 and replace with a new one (see: 3 - MAINTENANCE: FILTERS AND CARTRIDGES).
- Refit the access cover 8.

FILLING WITH OIL

- Clean and refit the drain plug 3.
- Fill up with oil (see: 3 - MAINTENANCE: LUBRICANTS) via the filler port 6.

⚠ IMPORTANT ⚠

Use a clean container and funnel and clean the underside of the oil drum before filling.

- Wipe the dipstick 4 and check the correct level between the MIN and MAX marks.
- Check for any possible leaks at the drain plug.
- Refit the filler plug 4.

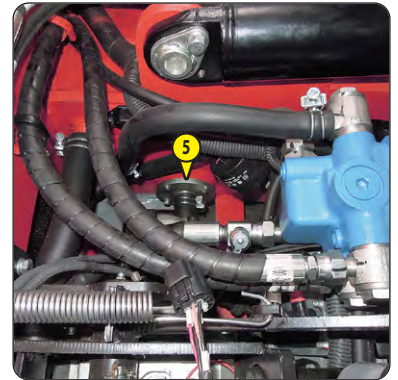
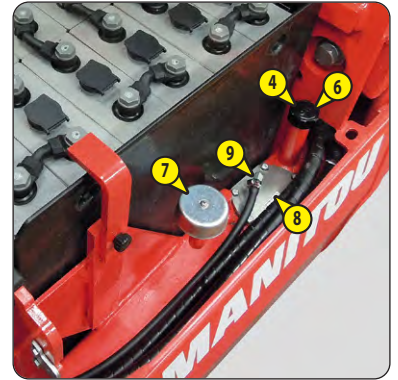

E6 – SEAT BELT

CHECK

⚠ IMPORTANT ⚠

*In no event should the lift truck be used if the seat belt is defective (fixing, locking, cuts, tears, etc.).
Repair or replace the seat belt immediately.*

- Check the following points:
 - Fixing of the anchoring points on the seat.
 - Cleanness of the strap and the locking mechanism.
 - Triggering of the locking mechanism.
 - Condition of the strap (cuts, curled edges).
 - Correct winding of the belt.
 - Condition of the reel guards.
 - Roller locking mechanism by giving the strap a sharp tug.

NOTE: After an accident, replace the seat belt.

F - OCCASIONAL MAINTENANCE

F1 – BATTERY TRAY

REMOVE

Place the lift truck on level ground.

- Raise the battery cover (see: 2 - DESCRIPTION: INSTRUMENTS AND CONTROLS).
- Disconnect the battery plug 1.
- Remove the right- and left-hand side casings.
- Place the hooks in the fastening points 2 provided for this purpose.
- Remove the battery tray locking mechanism 3.
- Carefully lift the battery 4 and remove it via the right-hand side 5.
- Carefully set down the battery.

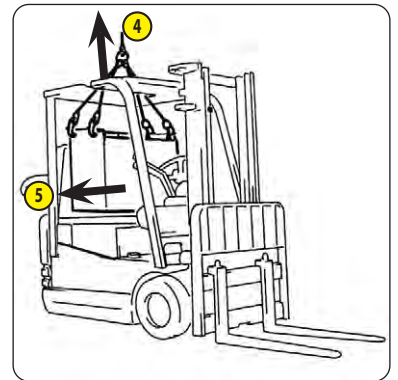
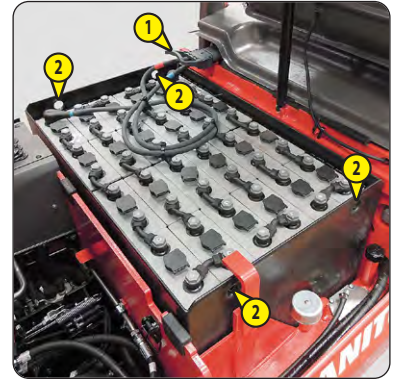

F2 – LIFT TRUCK

TOWING

⚠ IMPORTANT ⚠

The lift truck must be towed very slowly (less than 5 km/h) and for as short a distance as possible (less than 100 m).

- Set the forward/reverse lever to neutral.
- Release the hand brake.
- Since there will be no steering or braking assistance, operate the steering and pedal slowly avoiding sudden or jerky movements.
- Switch off the ignition to avoid damaging the electrical boards.

F3 – LIFT TRUCK

SLINGING

- Take into account the position of the lift truck center of gravity 1 for lifting.

A = 660 mm	B = 590 mm	ME 315 / ME 315 FOB
A = 731 mm	B = 627 mm	ME 316 / ME 316 FOB
A = 754 mm	B = 604 mm	ME 318 / ME 318 FOB
A = 819 mm	B = 646 mm	ME 320 / ME 320 FOB
- Place the hooks in the fastening points 2 provided.

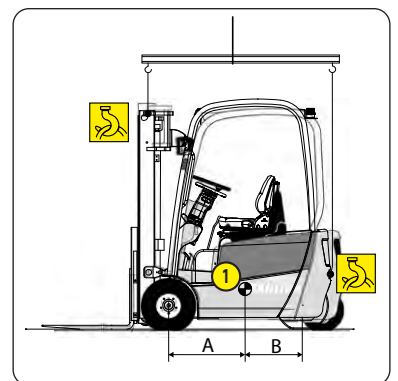

⚠ IMPORTANT ⚠

Ensure that the safety instructions associated with the platform are complied with before loading the lift truck and that the driver of the carrier vehicle is informed of the dimensions and the weight of the lift truck (see 2 - DESCRIPTION: CHARACTERISTICS).

Ensure that the platform is of sufficient size and load capacity for transporting the lift truck. Check also the allowable ground contact pressure of the platform relative to the lift truck.

LOADING THE LIFT TRUCK

- Block the wheels of the platform 1.
- Attach the loading ramps to the platform in such a way as to give the shallowest possible ramp angle for the lift truck.
- Load the lift truck parallel to the platform.
- Shut down the lift truck (see: 1 - OPERATING AND SAFETY INSTRUCTIONS: DRIVING INSTRUCTIONS UNLADEN AND LADEN).

STOWING THE LIFT TRUCK

- Fix the chocks 2 to the platform at the front and at the rear of each tire.
- Also fix the chocks 3 to the platform on the inside of each tire.
- Lash the lift truck onto the semi-trailer with sufficiently resistant ropes. In the front by passing above the articulation fittings 4 of the mast and at the rear onto the towing pin 5.
- Tighten the ropes 6.

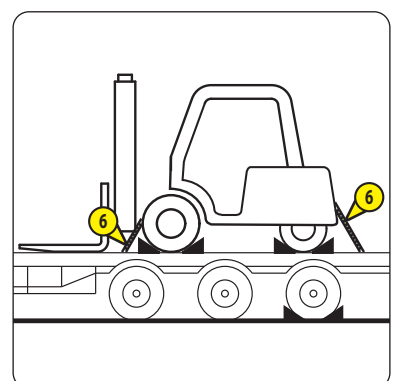
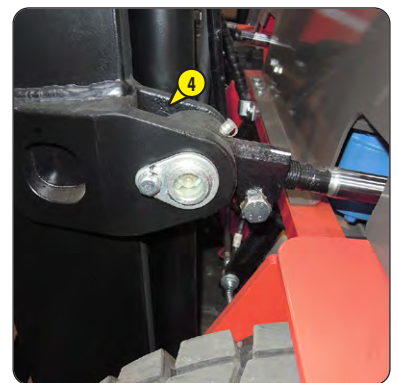
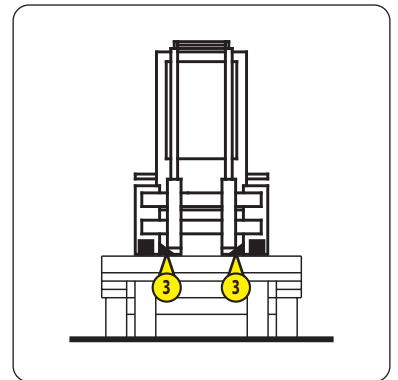
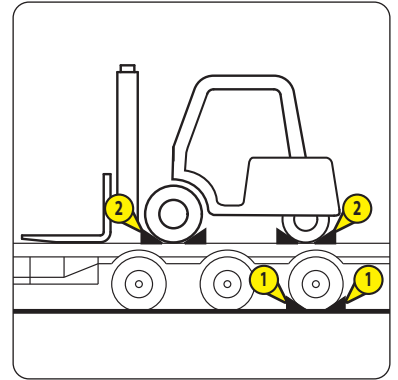

***4 - OPTIONAL
ADAPTABLE
ATTACHMENTS
FOR THE
RANGE***

TABLE OF CONTENTS

4 - OPTIONAL ADAPTABLE ATTACHMENTS FOR THE RANGE

<i>INTRODUCTION</i>	5
<i>TECHNICAL CHARACTERISTICS OF ATTACHMENTS</i>	6
<i>ATTACHMENT SHIELDS</i>	8

INTRODUCTION

Your lift truck must be used with interchangeable equipment. These items are called: ATTACHMENTS.

A wide range of attachments is available, guaranteed by MANITOU and designed to fit your lift truck perfectly.

⚠ IMPORTANT ⚠

*Only attachments approved by MANITOU are to be used on our lift trucks
(see: 4 - ADAPTABLE ATTACHMENTS IN OPTION ON THE RANGE: TECHNICAL SPECIFICATIONS OF ATTACHMENTS).
The manufacturer shall not be liable for any modification or adaptation of an attachment made without its knowledge.*

The attachments are delivered with a load chart concerning your lift truck. The operator's manual and the load chart should be kept in the places provided in the lift truck. For standard attachments, their use is governed by the instructions contained on this notice.

⚠ IMPORTANT ⚠

*Maximum loads are defined by the capacity of a lift truck taking account of the attachment's mass and center of gravity.
In the event of the attachment having less capacity than the lift truck, never exceed this limit.*

All attachments with a suspended load (winch, crane jib, crane jib with winch, hook, etc.) MUST be used with a lift truck equipped with a hydraulic movement cut-out device. In this case, the movement cut-out must be switched on and the transverse attitude perfectly horizontal.

Some particular uses require the adaptation of the attachment which is not provided in the price-listed options. Optional solutions exist, consult your dealer.

TECHNICAL CHARACTERISTICS OF ATTACHMENTS

- *: Double mast with all-round vision (DVT)
- ***: Double mast with free-acting lift (DLL)
- ***: Triple mast with free-acting lift (TLL)

FORK POSITIONER

PART NO.	(*)	(**) (***)
Rated capacity	257627 kg	313446 kg
Spacing	- mm	- mm
Width	mm	mm
Ground	kg	kg



STANDARDIZED FORK

ME 315 48V S3 / ME 316 48V S3 / ME 318 48V S3 / ME 315 48V S3 FOB / ME 316 48V S3 FOB / ME 318 48V S3 FOB

PART NO.	306169	315873	315874
Section	100 x 35 x 1070 mm	100 x 35 x 1150 mm	100 x 35 x 1220 mm
Ground	kg	kg	kg

PART NO.	52502484
Section	100 x 35 x 1520 mm
Ground	kg

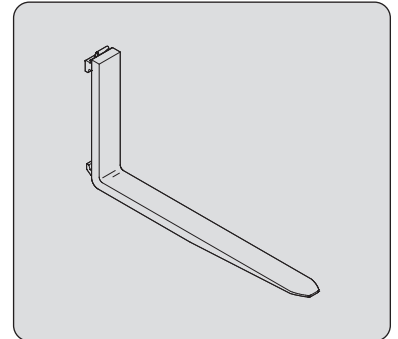

STANDARDIZED FORK

ME 320 48V S3 / ME 320 48V S3 FOB

PART NO.	52514626	306170	315877
Section	122 x 40 x 1070 mm	122 x 40 x 1150 mm	122 x 40 x 1220 mm
Ground	kg	kg	kg

PART NO.	52502488
Section	122 x 40 x 1520 mm
Ground	kg

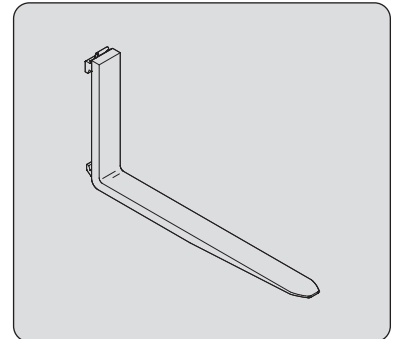

LOAD BACK REST

PART NO.

52532046

Width

1200 mm

Ground

kg



ATTACHMENT SHIELDS

FORK PROTECTOR

PART NO.

227801

