



649470EN-USMG(C-04/2024)  
(WORLDWIDE)

OPERATORS MANUAL  
(NOTICE ORIGINALE)

MRT 3060 360 175Y ST5 S1  
MRT-X 3060 360 175Y ST3A S1  
MRT 2570 360 175Y ST5 S1  
MRT-X 2570 360 175Y ST3A S1



*This manual applies to vehicles equipped with software version 1.2.25 or later.*

## LEGAL NOTICE

This brochure is provided for information only. Any reproduction, copy, representation, recording, transfer, distribution, etc., in whole or in part, in any format whatsoever, is prohibited. The diagrams, drawings, images, comments and indications found in this documentation, and the organization of the document itself, are intellectual property of MANITOU BF. Any violation of the above is subject to civil and criminal penalties. The logos and visual identity of the company are property of MANITOU BF and may not be used without express formal authorization. All rights reserved.

Any reproduction, source code access, decompilation, modification, copy (other than backup copies), correction of errors, transmission or distribution of any software built into Manitou machines is strictly prohibited.

In the event that the measures above nevertheless prove essential to enable use of the software, in accordance with its destination, or to obtain the information required for interoperability with other software created independently, the user should contact Manitou in advance and may, at its sole discretion, take the necessary measures or give access to only the information strictly necessary for interoperability.

Any breach of these requirements is likely to constitute a counterfeiting offense subject to legal action by Manitou.

Connected Manitou machines are equipped with boxes that collect technical data on the machines (such as geo-tracking data or data on component operation). This data, which is organized, processed and enhanced by algorithms and expertise proprietary to Manitou, constitutes a protected database under Article L.341-1 of the Intellectual Property Code.

It is strictly forbidden to have access to all or part of this database and to use the data (including in the event of accidental access) without explicit prior authorization from Manitou. In the event that Manitou authorizes a Manitou machine user to access all or part of this database, Manitou, as producer of this database, cedes to the user only a right to personal, non-exclusive, nontransferable use of the database, and only by access to an information technology platform hosted by a server owned or controlled by Manitou.

In any case, the following are strictly prohibited:

- any extraction, reproduction, representation, reuse through provision to the public, distribution, transfer, permanent or temporary, on any medium, by any means, and in any form whatsoever, of all or of a qualitatively or quantitatively substantial part of the contents of this database,
- any extraction, reproduction, representation, reuse through provision to the public, distribution, transfer, repeated or systematic of qualitatively or quantitatively insubstantial parts of the content of the database during operations manifestly exceeding normal use of the database by the user of the machine for his own needs,
- any use of means to bypass technical protection measures for databases or software source code embedded in the boxes, in keeping with Article L.331-5 of the Intellectual Property Code.

MANITOU BF S.A. Public limited company with a board of directors.

Head Office: 430 rue de l'Aubinière - 44150 Ancenis - France

Share capital: €39,548,949

Entered in the Nantes Trade and Companies Register under No. 857 802 508.

Tel.: +33 (0)2 40 09 10 11

[www.manitou.com](http://www.manitou.com)

|   |           |
|---|-----------|
| <b>1. SAFETY</b>  | <b>12</b> |
| <b>1.1. ORIGINAL SPARE PARTS AND EQUIPMENT</b>                                | <b>12</b> |
| <b>1.2. RECOMMENDATIONS FOR USE FOR THE DRIVER</b>                            | <b>12</b> |
| <b>1.3. GENERAL INSTRUCTIONS</b>  | <b>14</b> |
| 1.3.1 Instruction Manual  | 14        |
| 1.3.2 Driving authorization   | 14        |
| 1.3.3 Routine maintenance   | 14        |
| 1.3.4 Environmental conditions of use   | 14        |
| <b>1.4. DRIVING INSTRUCTIONS</b>  | <b>15</b> |
| 1.4.1 Driver seat provisions  | 15        |
| 1.4.2 Before starting the forklift  | 15        |
| 1.4.3 Starting the forklift   | 15        |
| 1.4.4 Telehandler guide   | 16        |
| 1.4.5 Stopping the telehandler  | 16        |
| 1.4.6 Driving the telehandler on the road                                     | 17        |
| <b>1.5. HANDLING INSTRUCTIONS</b>   | <b>17</b> |
| 1.5.1 Handling instructions   | 17        |
| <b>1.6. HANDLING OF A LOAD</b>  | <b>19</b> |
| 1.6.1 Load weight and center of gravity                                       | 19        |
| 1.6.2 Picking up a load from the ground                                       | 20        |
| 1.6.3 Pick up a load up on tires  | 21        |
| 1.6.4 Picking up a load without a pallet                                      | 22        |
| 1.6.5 Load status indicator device  | 22        |
| <b>1.7. INSTRUCTIONS FOR USING THE RADIO CONTROL</b>                          | <b>23</b> |
| 1.7.1 Recommendations for using the remote control                            | 23        |
| <b>1.8. TRANSLATION OF THE VEHICLE BY RADIO CONTROL</b>                       | <b>26</b> |
| 1.8.1 Translation of the telehandler by remote control or platform (optional) | 26        |
| 1.8.2 Safety requirements for translation by remote control                   | 26        |
| 1.8.3 Platform transfer safety requirements (basket)                          | 26        |
| <b>1.9. TELEHANDLER MAINTENANCE INSTRUCTIONS</b>                              | <b>27</b> |
| 1.9.1 Recommendations for maintenance   | 27        |
| <b>2. TECHNICAL DATA AND DESCRIPTION</b>                                      | <b>29</b> |

|  |           |
|--|-----------|
| <b>2.1. MACHINE IDENTIFICATION .....</b>   | <b>29</b> |
| 2.1.1 IDENTIFICATION OF THE ROTATING TELESCOPIC HANDLER .....  | 29        |
| 2.1.2 IDENTIFICATION OF THE ROTATING TELESCOPIC HANDLER .....  | 29        |
| 2.1.3 HEAT ENGINE PLATE .....  | 29        |
| 2.1.4 HYDROSTATIC PUMP PLATE.....  | 30        |
| 2.1.5 HYDROSTATIC MOTOR PLATE.....   | 30        |
| 2.1.6 GEARBOX PLATE .....  | 31        |
| 2.1.7 FRONT AXLE PLATE.....  | 31        |
| 2.1.8 REAR AXLE PLATE.....   | 32        |
| 2.1.9 CABIN PLATE .....  | 32        |
| 2.1.10 CHASSIS PLATE.....  | 32        |
| 2.1.11 ACCESSORY MANUFACTURER'S PLATE .....  | 33        |
| <b>2.2. TECHNICAL SPECIFICATIONS .....</b>   | <b>33</b> |
| 2.2.3 FEATURES MRT 2570 and 3060 .....   | 39        |
| 2.2.4 FEATURES MRT-X 2570 and 3060 .....   | 42        |
| 2.2.7 CAPACITY AND LOAD CHARTS .....   | 50        |
| 2.2.8 "CE" DECLARATION OF CONFORMITY.....  | 59        |
| <b>2.3. ENVIRONMENT .....</b>  | <b>61</b> |
| 2.3.1 EXHAUST GAS AFTER-TREATMENT SYSTEM (DPF + SCR + EGR) AND POLLUTANT GAS<br>EMISSIONS CONTROL..... | 61        |
| <b>2.4. COMPONENTS .....</b>   | <b>64</b> |
| 2.4.1 CONTROLS .....   | 64        |
| 2.4.2 Pedals and diagnosis sockets .....   | 65        |
| 2.4.3 ADJUSTABLE STEERING COLUMN LEVER .....   | 65        |
| 2.4.4 CONTROL LEVER FOR LIGHTS, HORN, INDICATOR LIGHTS AND WIPERS.....                                 | 66        |
| 2.4.5 SIDE REAR VIEW MIRRORS and USB PORT.....   | 67        |
| 2.4.6 SUNSHADE .....   | 67        |
| 2.4.7 DISPLAY HEIGHT ADJUSTMENT KNOB .....   | 68        |
| 2.4.8 Cabin accessories .....  | 68        |
| 2.4.9 Ceiling light and rear window opening lever.....   | 68        |
| 2.4.10 Opening the door and door window .....  | 68        |
| 2.4.11 DOOR WINDOW RELEASE LEVER FROM INSIDE CABIN .....   | 69        |
| 2.4.12 DOOR WINDOW RELEASE LEVER FROM OUTSIDE CABIN .....  | 69        |
| 2.4.13 Air diffusers .....   | 69        |
| 2.4.14 Registration plate .....  | 70        |

|  |            |
|--|------------|
| 2.4.15 HEADLIGHTS .....  | 70         |
| 2.4.16 Beacon and signal headlights .....  | 71         |
| 2.4.17 BATTERY DISCONNECT SWITCH.....  | 71         |
| 2.4.18 BOOM SAFETY WEDGE .....   | 71         |
| <b>2.5. OPERATOR AREA.....</b>   | <b>72</b>  |
| 2.5.1 GETTING IN AND OUT OF THE VEHICLE.....   | 72         |
| 2.5.2 A - DRIVER'S SEAT (standard).....  | 72         |
| 2.5.3 B - PNEUMATIC SEAT FOR DRIVER ( <b>optional</b> ).....                         | 73         |
| 2.5.4 C - HEATED / AIR-CONDITIONED DRIVER'S SEAT (optional) .....                    | 74         |
| 2.5.5 SEAT BELT .....  | 75         |
| 2.5.6 IGNITION SWITCH.....   | 75         |
| 2.5.7 "Easy MANAGER" ANTI-START SYSTEM (optional).....                               | 75         |
| <b>2.6. DISPLAY.....</b>   | <b>76</b>  |
| 2.6.1 DISPLAY CONTROL.....   | 76         |
| 2.6.2 DISPLAY ICONS .....  | 77         |
| 2.6.3 DISPLAY PAGES.....   | 79         |
| 2.6.4 BUTTON BAR .....   | 81         |
| 2.6.5 MENU PAGES.....  | 83         |
| 2.6.6 "DRIVE" PAGE .....   | 84         |
| 2.6.7 "WORKING" PAGE .....   | 84         |
| 2.6.8 "STABILITY" PAGE .....   | 86         |
| 2.6.9 "ADJUSTMENTS" PAGE.....  | 87         |
| 2.6.10 "DIAGNOSTICS" PAGE.....   | 88         |
| 2.6.11 "SETTINGS" PAGE .....   | 89         |
| 2.6.12 "RESOURCES" PAGE .....  | 90         |
| 2.6.13 "INFORMATION" PAGE .....  | 91         |
| <b>2.7. CHECK INDICATORS.....</b>  | <b>92</b>  |
| 2.7.1 JOYSTICK .....   | 92         |
| 2.7.2 BUTTONS AND CONTROLS .....   | 93         |
| 2.7.3 SAFETY SYSTEM EXCLUSION KEY .....  | 98         |
| 2.7.4 STANDARD RADIO CONTROL FOR ATTACHMENT HANDLING.....                            | 98         |
| <b>2.8. OPTIONAL.....</b>  | <b>102</b> |
| 2.8.1 AIR CONDITIONING.....  | 102        |
| 2.8.2 BOOM SUSPENSION.....   | 102        |
| 2.8.3 HYDRAULIC BLOCK OF THE ATTACHMENT .....  | 103        |
| 2.8.4 FRONT AND SIDE CAMERA SYSTEM .....   | 104        |
| 2.8.5 RADIO CONTROL FOR ATTACHMENT MOVEMENT AND TELESCOPIC HANDLER<br>MOVEMENT ..... | 105        |

|  |            |
|--|------------|
| 2.8.6 PREPARING BI-ENERGY UNIT .....                                       | 108        |
| <b>3. USE OF THE MACHINE</b> .....   | <b>109</b> |
| <b>3.1. BEFORE USING THE MACHINE</b> .....                                 | <b>109</b> |
| 3.1.1 PRE-USE INSPECTION CHECKLIST .....                                   | 109        |
| 3.1.2 AREA AROUND THE TELEHANDLER.....                                     | 110        |
| 3.1.3 FILLING THE FUEL TANK.....   | 110        |
| 3.1.4 FILLING THE "DEF" TANK .....   | 110        |
| 3.1.5 WORK AREA INSPECTION .....   | 111        |
| <b>3.2. ENTER THE CABIN</b> .....  | <b>112</b> |
| 3.2.1 GETTING IN AND OUT OF THE VEHICLE .....                              | 112        |
| <b>3.3. TURNING THE MACHINE ON AND OFF</b> .....                           | <b>113</b> |
| 3.3.1 STARTING THE MACHINE .....   | 113        |
| 3.3.2 TURNING OFF THE MACHINE .....  | 113        |
| <b>3.4. USE OF ATTACHMENTS</b> .....                                       | <b>114</b> |
| 3.4.1 SAFETY RECOMMENDATIONS FOR ATTACHMENTS .....                         | 114        |
| 3.4.2 COUPLING MANEUVER FOR ATTACHMENTS .....                              | 115        |
| 3.4.3 AUTOMATIC RECOGNITION OF THE "E-RECO" ATTACHMENT.....                | 117        |
| 3.4.4 FLOW LIMITER OF THE ATTACHMENT CIRCUIT .....                         | 118        |
| <b>3.5. DRIVING THE MACHINE</b> .....                                      | <b>118</b> |
| 3.5.1 USING STEERING MODES .....   | 118        |
| 3.5.2 USING THE SEMI-AUTOMATIC WHEEL ALIGNMENT .....                       | 119        |
| 3.5.3 USING THE PARKING BRAKE.....   | 120        |
| 3.5.4 DRIVING MODES.....   | 120        |
| 3.5.5 USING THE FORWARD / NEUTRAL / REVERSE DIRECTION SELECTOR (FNR) ..... | 121        |
| 3.5.6 TRAVEL SAFETY SYSTEM RESET BUTTON .....                              | 121        |
| <b>3.6. STABILITY OF THE MACHINE</b> .....                                 | <b>122</b> |
| 3.6.1 LEVELING PROCEDURE (ON TIRES) .....                                  | 122        |
| 3.6.2 BLOCKING REAR AXLE SWING.....  | 123        |
| 3.6.3 STABILIZER MOVEMENTS .....   | 123        |
| 3.6.4 MANUAL STABILIZATION PROCEDURE.....                                  | 123        |
| 3.6.5 AUTOMATIC STABILIZATION PROCEDURE.....                               | 124        |
| 3.6.6 STABILIZERS AUTOMATIC LEVELING PROCEDURE .....                       | 125        |
| <b>3.7. EMERGENCY PROCEDURES</b> .....                                     | <b>125</b> |

|  |            |
|--|------------|
| 3.7.1 EMERGENCY PROCEDURE .....  | 125        |
| <b>3.8. USE OF TOWING DEVICES.....</b>   | <b>126</b> |
| 3.8.1 PIN AND TOWING HOOK .....  | 126        |
| 3.8.2 COUPLING FORK.....   | 126        |
| <b>3.9. TRANSPORT OF THE MACHINE .....</b>                                       | <b>127</b> |
| 3.9.1 TRANSPORTING THE TELESCOPIC HANDLER ON A TRAILER .....                     | 127        |
| 3.9.2 PUTTING THE TELEHANDLER IN A SLING AND LIFTING IT .....                    | 129        |
| 3.9.3 TOWING OR HOOKING THE TELEHANDLER.....                                     | 130        |
| 3.9.4 TOWING OR HOOKING THE TELEHANDLER.....                                     | 131        |
| <b>4. MAINTENANCE .....</b>  | <b>133</b> |
| <b>4.1. MAINTENANCE INTERVALS.....</b>   | <b>133</b> |
| 4.1.1 DAILY AND WEEKLY MAINTENANCE .....   | 133        |
| 4.1.2 1st MANDATORY SERVICE WITHIN THE FIRST 500 HOURS OR WITHIN 6 MONTHS .....  | 133        |
| 4.1.3 PERIODIC MAINTENANCE .....   | 133        |
| 4.1.4 MAINTENANCE AND OCCASIONAL OPERATIONS .....                                | 133        |
| <b>4.2. SCHEDULED MAINTENANCE .....</b>  | <b>133</b> |
| 4.2.1 1st MANDATORY SERVICE WITHIN THE FIRST 500 HOURS OR WITHIN 6 MONTHS.....   | 133        |
| 4.2.2 DAILY AND WEEKLY MAINTENANCE .....   | 134        |
| 4.2.3 PERIODIC MAINTENANCE .....   | 135        |
| 4.2.4 OCCASIONAL MAINTENANCE.....  | 138        |
| <b>4.3. EVERY 10 HOURS OF OPERATION .....</b>                                    | <b>139</b> |
| 4.3.1 CHECKING THE OIL LEVEL IN THE ENGINE.....                                  | 139        |
| 4.3.2 CHECKING THE COOLANT LEVEL .....   | 139        |
| 4.3.3 CHECKING THE TELESCOPIC BOOM SLIDING SHOES.....                            | 140        |
| 4.3.4 CHECKING THE "MSS" SAFETY SYSTEM.....                                      | 141        |
| 4.3.5 CHECKING THE FUEL LEVEL.....   | 141        |
| 4.3.6 CHECKING DEF LIQUID LEVEL .....  | 142        |
| 4.3.7 FUEL PRE-FILTER CHECK .....  | 143        |
| 4.3.8 CABIN GLASS INTEGRITY CHECK .....  | 143        |
| 4.3.9 CABIN UPPER ANTI-BREAKAGE GLASS INTEGRITY CHECK (OPTIONAL) .....           | 145        |
| <b>4.4. EVERY 50 HOURS OF OPERATION .....</b>                                    | <b>146</b> |
| 4.4.1 HYDRAULIC OIL LEVEL CHECK .....  | 146        |
| 4.4.2 TIRE PRESSURE AND WHEEL NUT TIGHTENING CHECK.....                          | 147        |
| 4.4.3 CLEANING THE RADIATOR GRILLE, HYDRAULIC OIL, COOLANT AND INTERCOOLER ..... | 147        |

|   |            |
|---|------------|
| 4.4.4 WINDSCREEN WASHER FLUID LEVEL CHECK .....                                   | 148        |
| 4.4.5 CHECKING AND CLEANING THE CONDENSER GRILLE (OPTIONAL AIR CONDITIONER) ..... | 148        |
| 4.4.6 GENERAL LUBRICATION.....  | 148        |
| <b>4.5. EVERY 250 HOURS OF OPERATION .....</b>                                    | <b>152</b> |
| 4.5.1 FRONT AND REAR AXLE DIFFERENTIAL OIL LEVEL CHECK.....                       | 152        |
| 4.5.2 FRONT AND REAR WHEEL REDUCER OIL LEVEL CHECK .....                          | 152        |
| 4.5.3 GEARBOX OIL LEVEL CHECK .....   | 153        |
| 4.5.4 GEARBOX OIL LEVEL CHECK .....   | 153        |
| 4.5.5 BATTERY CHECK.....  | 154        |
| 4.5.6 ROTATION REDUCER FIXING SCREW TIGHTENING CHECK .....                        | 155        |
| 4.5.7 EXTERNAL BOOM CHAINS CHECK.....   | 155        |
| <b>4.6. EVERY 500 HOURS OF OPERATION OR EVERY 6 MONTHS .....</b>                  | <b>160</b> |
| 4.6.1 HYDRAULIC OIL CONTAMINATION CHECK .....                                     | 160        |
| 4.6.2 REPLACING THE HYDROSTATIC PUMP OIL FILTER (TRANSMISSION) .....              | 161        |
| 4.6.3 REPLACING THE HYDRAULIC OIL FILTER CARTRIDGE (DRAIN).....                   | 161        |
| 4.6.4 REPLACING THE HYDRAULIC OIL BREATHER.....                                   | 162        |
| 4.6.5 FIFTH WHEEL AND TURRET FIXING BOLTS CHECK .....                             | 162        |
| 4.6.6 CABIN VENTILATION FILTERS CHECK .....                                       | 163        |
| 4.6.7 FORKS WEAR CHECK.....   | 163        |
| <b>4.7. EVERY 1000 HOURS OF OPERATION OR EVERY YEAR .....</b>                     | <b>164</b> |
| 4.7.1 FILTER AND THREE-PHASE MOTOR OIL CHANGE .....                               | 164        |
| 4.7.2 FRONT AND REAR AXLE DIFFERENTIAL OIL CHANGE .....                           | 165        |
| 4.7.3 CHANGE FRONT AND REAR AXLE FINAL REDUCER OIL .....                          | 166        |
| 4.7.4 GEARBOX OIL CHANGE.....   | 166        |
| 4.7.5 GEARBOX OIL CHANGE AND SPEED SENSOR CLEANING .....                          | 167        |
| 4.7.6 DRY AIR FILTER CARTRIDGE REPLACEMENT .....                                  | 168        |
| 4.7.7 CLEANING THE FUEL TANK .....  | 169        |
| 4.7.8 FUEL PRE-FILTER REPLACEMENT .....   | 169        |
| 4.7.9 FUEL FILTER REPLACEMENT .....   | 170        |
| 4.7.10 FUEL PUMP FILTER REPLACEMENT .....   | 171        |
| 4.7.11 COOLANT REPLACEMENT .....  | 171        |
| 4.7.12 CABIN VENTILATION FILTERS REPLACEMENT .....                                | 172        |
| 4.7.13 WEAR OF THE EXTERNAL TELESCOPIC BOOM CHAINS CHECK.....                     | 173        |
| 4.7.14 WEAR OF THE EXTERNAL TELESCOPIC BOOM CHAINS CHECK.....                     | 175        |
| 4.7.15 CHECK FOR WEAR AND INCREASE IN CLEARANCE OF THE FIFTH WHEEL BEARINGS ..... | 176        |
| 4.7.16 REPLACE FILTER OF THE "DEF" BOOST PUMP .....                               | 177        |
| 4.7.17 REPLACE THE "DEF" TANK BREATHER.....                                       | 177        |
| 4.7.18 SAFETY BELT CHECK .....  | 178        |

|   |            |
|---|------------|
| <b>4.8. EVERY 2000 HOURS OF OPERATION OR EVERY 2 YEARS .....</b>  | <b>179</b> |
| 4.8.1 TIRE PRESSURE AND WHEEL NUT TIGHTENING CHECK.....   | 179        |
| 4.8.2 HYDRAULIC OIL REPLACEMENT AND HYDRAULICS INTAKE FILTER CARTRIDGE<br>CLEANING .....                                      | 179        |
| <b>4.9. EVERY 3000 HOURS OF OPERATION OR EVERY 3 YEARS .....</b>  | <b>181</b> |
| 4.9.1 AIR FILTER SAFETY CARTRIDGE REPLACEMENT .....   | 181        |
| 4.9.2 REPLACEMENT OF THE THREE-PHASE MOTOR SERVICE BELT.....  | 181        |
| <b>4.10. EVERY 4500 HOURS OF OPERATION OR EVERY 9 YEARS .....</b>   | <b>182</b> |
| <b>4.11. EVERY 6000 HOURS OF OPERATION OR EVERY 12 YEARS .....</b>  | <b>183</b> |
| 4.11.1 DIESEL PARTICULATE FILTER (DPF) OF THE THREE-PHASE MOTOR CHECK.....  | 183        |
| <b>4.12. EVERY 9000 HOURS OF OPERATION OR EVERY 18 YEARS .....</b>  | <b>183</b> |
| <b>4.13. OCCASIONAL MAINTENANCE .....</b>   | <b>183</b> |
| 4.13.1 INSERTING THE SAFETY WEDGE OF THE TELESCOPIC BOOM .....  | 183        |
| 4.13.2 WHEEL REPLACEMENT .....  | 184        |
| 4.13.3 HEADLIGHTS ADJUSTMENT .....  | 184        |
| 4.13.4 REPLACING THE FUSES AND RELAYS .....   | 185        |
| 4.13.5 CHECK AND CLEANING OF THE TRANSMITTER RINGS OF THE ROTATING ELECTRIC<br>COLLECTOR (AFTER 3 MONTHS OF INACTIVITY) ..... | 197        |
| 4.13.6 REMOTE CONTROL CHECK.....  | 197        |
| 4.13.7 CHECKING AND CLEANING THE FUEL TANK FILLER FILTER .....  | 200        |
| 4.13.8 CHECKING AND CLEANING THE DEF TANK FILLER FILTER.....  | 201        |
| 4.13.9 STATIONARY REGENERATION OF DPF FILTER "HANDLER STOPPED".....   | 201        |
| <b>5. REFERENCES, OPTIONS AND ACCESSORIES .....</b>   | <b>202</b> |
| <b>5.1. REFERENCES .....</b>  | <b>202</b> |
| 5.1.1 LUBRICANTS AND FUEL .....   | 202        |
| 5.1.2 FILTER ELEMENTS AND BELTS .....   | 205        |
| <b>5.2. ATTACHMENTS.....</b>  | <b>207</b> |
| 5.2.1 Interchangeable equipment and machine compatibility .....   | 207        |

## 00. EXPLANATION OF SYMBOLS

### **DANGER**

Indicates an imminent hazardous situation which, if not avoided will result in death or serious injury.

### **WARNING**

Indicates a potentially hazardous situation which, if not avoided, may result in death or serious injury.

### **CAUTION**

Indicates a potentially hazardous situation which, if not avoided, may result in minor injury or damage to property. It is also used to warn users of unsafe practices.

### **NOTICE**

Indicates a practice not related to a physical injury which, if not avoided, may damage the machine.



*Indicates a message to draw attention to important information regarding environmental protection.*



*Indicates special tools for performing a task.*



*Indicates the value of tightening torque to be applied.*



*Indicates the weight of an item.*

e.g. it helps to anticipate an action linked to a person's health or the choice of lifting equipment.

# 1. SAFETY

## 1.1. ORIGINAL SPARE PARTS AND EQUIPMENT

### ⚠ WARNING

Our forklifts must imperatively be maintained with original parts.

By authorizing the use of non-original parts, you risk:

- Legally involving your liability in the event of an accident.
- Technically causing malfunctions to the longevity of the telehandler.

### ⚠ WARNING

The use - by the user - of counterfeit parts or non-approved components can put an end to the contractual warranty conditions and lead the manufacturer to withdraw the Certificate of Conformity.

By using the original parts during maintenance operations, you are legally protected:

- The user who supplies elsewhere does so at his own risk.
- The user who modifies, or has the telehandler modified by third parties, must be aware that a new material is put on the market, which involves his liability.
- The user who copies or has copies made of the original parts exposes himself to legal risks.
- The Certificate of Conformity implies the liability of the manufacturer only for the parts chosen or processed under his control.
- Practical maintenance conditions are set by the manufacturer. If the user does not respect them, the liability of the manufacturer is not involved.

The manufacturer provides the user with:

- Savoir faire and its expertise.
- The guarantee of the quality of the works carried out.
- The original spare parts.
- Preventive maintenance assistance.
- Effective diagnosis assistance.
- The improvements due to an exchange of expertise.
- The training of the staff in charge.

- Only the manufacturer knows in detail the design of the forklift and therefore the best technological capabilities to ensure its maintenance.

### NOTICE

Original spare parts are distributed exclusively by MANITOU and the dealer network.

## 1.2. RECOMMENDATIONS FOR USE FOR THE DRIVER

### ⚠ WARNING

Most of the accidents related to the use, maintenance and repair of the telehandler are due to the non-application and non-observance of the most basic safety rules.

By identifying the risks to which you expose yourself and taking all necessary precautions, you can avoid these accidents.

### ⚠ WARNING

All operations or maneuvers not described in the instruction manual must be avoided, and in any case anyone who uses another method must first ensure that his own safety, that of others and the good condition of the telehandler are guaranteed.

Therefore, not being able to foresee all the dangerous situations, the recommendations and safety standards relating to the telehandler, given by the manufacturer and reported in this manual, are not to be considered exhaustive.

### ⚠ WARNING

Failure to comply with the safety regulations or the recommendations for use, maintenance or repair of the telehandler can cause serious injury, even death.

### ⚠ WARNING

We draw the attention of users to the risks they face, going at an excessive speed compared to the conditions of circulation, in particular:

Risk of losing control on a rough road.

Increased braking distance.

**⚠ WARNING**

The user must always be able to control the telehandler and therefore must:

Adapt the speed to any situation to preserve your own safety, that of others and that of your machine

Continuously evaluate the braking distance.

**⚠ WARNING**

Experience teaches us that there may be some contraindications to the use of the telehandler.

These foreseeable anomalous uses, the main ones of which are listed below, are formally prohibited.

1. The predictable abnormal behavior, which results from ordinary negligence, but which does not result from the will to misuse the machine.
2. The reflex behavior of a person in case of malfunction, accident, anomaly, etc. while using the telehandler.
3. The behavior resulting from the application of the "law of least effort" when performing a task.
4. For some machines, the predictable behavior of certain categories of people, such as:
  - 4.1. apprentices,
  - 4.2. handicapped,
  - 4.3. staff in training.
5. Drivers tempted to use the telehandler for betting, competitions or from personal experience

**⚠ WARNING**

The plant or site manager must take these criteria into account when assessing a person's ability to drive.

Familiarize yourself with the telehandler on the ground where it will be used.

Transport the load in the low position and with the telescopic boom retracted to the maximum (transport condition).

Position the forks perpendicular to the load to be lifted.

Drive the telehandler at a speed appropriate to the conditions and condition of the ground.

Never go too fast or brake hard with a load.

When picking up a load, make sure the ground is as even as possible.

Do not attempt to perform operations that exceed the capabilities of the telehandler.

Do not lift a load greater than the capacity of the telehandler and do not increase the size of the counterweight.

Go around the obstacles.

Pay attention to electric cables, ditches, recently excavated or brought back land.

Never leave the engine running in the absence of the driver.

Use the parking brake when placing a difficult load or on sloping ground.

Never leave the telehandler parked with a raised load.

Do not allow anyone to approach or pass under a load.

Always think about safety and only carry well-balanced loads.

Never lift a load using only one fork.

Drive carefully and alert.

When the telehandler is not in use, lower the forks to the ground and apply the parking brake.

Never leave the ignition key on the telehandler when the driver is absent.

Do not leave the telehandler loaded on a slope greater than 15% even with the parking brake applied.

When lifting a load, make sure that nothing or no one hinders the movement and avoid making false maneuvers.

Observe the data indicated on the load diagrams.

Never carry another person on the telehandler.

**⚠ WARNING**

Whenever a tool is changed, to avoid damaging the hydraulic fittings it is necessary to:

stop the three-phase motor and wait about 1 minute to release the pressure from the circuit.

Wait about 1 minute to release the pressure from the circuit.

## 1.3. GENERAL INSTRUCTIONS

### 1.3.1 INSTRUCTION MANUAL

1. Read carefully and understand the instruction manual.
2. The instruction manual must always be in its place in the telehandler and be in the language spoken by the operator
3. Observe the safety rules and recommendations described for the telehandler.
4. It is imperative to replace all plates or stickers that have become illegible or damaged.

### 1.3.2 DRIVING AUTHORIZATION

**i** *Observe the legislation in force in the country of use*

Only qualified and specially trained personnel can use the telehandler. Its use is compulsorily subject to the driving authorization issued by the manager of the plant where the machine is used.

- The user is advised to always have driving authorization with him during service.
- The user is advised to always have driving authorization with him during service.
- The use must also comply with the rules of the profession.

### 1.3.3 ROUTINE MAINTENANCE

The user who finds that his telehandler is not working well or does not comply with safety regulations must immediately inform the person in charge.

#### **⚠ DANGER**

The driver is prohibited from making any repairs or adjustments unless he has been trained for such a task.

You will need to keep your telehandler in perfect condition if you have been instructed to do so.

Carry out daily maintenance.

Check that the tires are suitable for the type of terrain.

#### **⚠ DANGER**

Do not use worn or deteriorated tires.

#### **⚠ DANGER**

Fitting tires inflated with polyurethane foam is prohibited and is not guaranteed by the manufacturer, unless authorized.

#### **⚠ DANGER**

Do not modify the structure or the adjustment of the various components of the telehandler (hydraulic pressure, setting of the limiters, engine speed, installation of additional attachments, etc.).

The same applies to the deactivation or modification of the safety systems. In these cases, the manufacturer will be released from any liability.

To keep the telehandler in a "state of conformity", it is mandatory to carry out periodic checks. The frequency of checks is defined by the legislation in force in the country of use of the telehandler. Maintenance operations or repairs must be carried out by qualified personnel and respecting the safety conditions to ensure your safety and that of others.

### 1.3.4 ENVIRONMENTAL CONDITIONS OF USE

Equip the telehandler with a fire extinguisher if the machine is used in a place without extinguishing equipment. There are optional solutions. For more information, contact your agent or dealer.

Always take into account the climatic and atmospheric conditions of the place of use.

The filling of lubricants has already been carried out in the factory using lubricants for average climatic conditions of use, i.e. from -15° C to + 35° C. For use in extreme conditions it is necessary, before starting, to empty and refill, using lubricants suitable for such temperatures. The same applies to the coolant (-21° C).

#### **⚠ CAUTION**

**Use of the telehandler in adverse weather conditions (very cold temperatures) is only allowed with suitable fuels and/or with antifreeze.**

Failure to do so could cause your telehandler to malfunction.

**⚠ CAUTION**

The use of the telehandler is prohibited in protected spaces (e.g. : Refineries, explosive atmosphere).

For use in these spaces, specific optional attachments exists. Contact your agent or dealer.

**1.4. DRIVING INSTRUCTIONS****1.4.1 DRIVER SEAT PROVISIONS**

1. Wear clothing suitable for driving the telehandler, avoiding those that are too loose. Never ride with wet or greasy hands or shoes.
2. For better comfort, adjust the driver's seat and adopt a good driving position.
3. The driver must always maintain the normal driving position.
4. Always fasten and adjust the seat belt.
5. The control components must never be used for purposes other than those for which they are designed (e.g. : Getting on or off the telehandler, hanging clothes, etc.).

**⚠ DANGER**

Never allow passengers to get on the telehandler or in the driver's seat.

**⚠ DANGER**

It is forbidden to protrude arms and legs and, in general, any part of the body, outside the driving position of the telehandler.

**1.4.2 BEFORE STARTING THE FORKLIFT**

1. Check the condition and pressure of the tires.
2. Before starting, check the fluid levels:
  - 2.1. Thermal engine oil.
  - 2.2. Hydraulic tank oil.
  - 2.3. Transmission oil.
  - 2.4. Coolant.
3. Check for oil, fuel or liquid leaks on the telehandler.
4. Make sure that the engine cover is closed and locked correctly.

**⚠ DANGER**

The user, whatever his level of experience as a handler, must familiarize himself with the location and use of all the control and command instruments before putting the telehandler into service.

**1.4.3 STARTING THE FORKLIFT****⚠ DANGER**

The telehandler can only be started or maneuvered when the driver is in the driver's seat, with the seat belt fastened and adjusted.

**⚠ CAUTION**

Do not tow or push the forklift to start it.

This maneuver could cause serious damage to the transmission. If it is necessary to tow the telehandler, put the gearbox in neutral position.

1. Verify that the reverse gear lever is in idleoff.
2. Turn the ignition key to position I to allow electrical contact.
3. Check the fuel level on the gage.
4. Turn the ignition key to position II to allow preheating and wait 15 seconds. (If environmental conditions so require)

**⚠ DANGER**

Do not activate the starter for more than 15 seconds, and allow it to preheat for 10 seconds between all attempts.

5. Turn the ignition key fully.
6. Release the ignition key and let the engine run at low speed.
7. Look at all control instruments immediately after starting, with the engine warm, and at regular intervals during use, in order to quickly identify and resolve any faults. If any of the instruments indicates a fault, stop the engine and carry out the necessary operations right away.

**⚠ DANGER**

Before operating in very cold climatic environments, wait for the three-phase motor and hydraulic systems to warm up correctly.

**1.4.4 TELEHANDLER GUIDE****⚠ DANGER**

The use of the seat belt is mandatory and must be adjusted to the height of the operator.

While driving the telehandler, the door must be closed.

- Always fasten and adjust the seat belt.
- Close the door.
- Practice driving the forklift on the ground where it will operate.
- Check the efficiency of the service brakes and the horn.
- Drive appropriately by choosing the appropriate speed for the conditions and the type of terrain.
- Slow down before making a turn.
- Be in control of the forklift and its speed under all circumstances.
- On wet, slippery or uneven ground, drive slowly.
- Brake progressively, avoid sudden braking.
- Act on the reverser of the telehandler only when the machine is stationary, avoiding sudden maneuvers.
- Always remember that the hydraulic steering is very sensitive to the movements of the steering wheel, therefore it is necessary to steer progressively and not jerky.
- Never leave the engine running without the driver.
- Always look in the direction of travel and maintain good visibility of the route. Use the side mirrors frequently, and check their condition, cleanliness and adjustment.
- Do not use the forklift in dark or poorly lit environments.
- At night, check that the telehandler is equipped with work lights.
- Get around the obstacles.
- Do not enter a loading bridge without having checked:
  - That it is correctly positioned and anchored.
  - That the vehicle to which it is connected (wagon, truck, etc.) cannot be moved.

- That this bridge can bear the total weight of the telehandler and its load.
- That the width of the bridge is adequate for that of the forklift.
- That the width of the bridge is adequate for that of the forklift.
- Never enter a gangway, a platform or a freight elevator without being sure that they are designed for the weight and dimensions of the telehandler and its load, and without having checked that they are in good condition.

**⚠ CAUTION**

The travel speed of the loaded telehandler must never exceed 5 km/h (3.1 mph).

**⚠ DANGER**

Move the telehandler into transport position, i.e. boom retracted and 300 mm (11.8 in) from the ground.

1. Check the transmission oil level.
2. Place the forks or attachment in the transport position, i.e. boom retracted and 300 mm (11.8 in) above the ground.
3. Place the reverse lever in the desired position.
4. Release the parking brake and accelerate gently to allow the telehandler to move.

**1.4.5 STOPPING THE TELEHANDLER**

- Before stopping the telehandler after intense work, let the three-phase motor idle for a few moments to allow the coolant and oil to lower the engine and transmission temperatures.
- Never leave the ignition key on the telehandler without the driver.
- When the telehandler is stationary, place the forks or attachment on the ground, place the shift lever in neutral, apply the parking brake and place the marine gear lever in neutral.
- If the driver has to leave the driver's seat, even temporarily, apply the parking brake and put the gearbox lever in neutral.
- Make sure the telehandler is parked in such a way as not to impede traffic and at least one meter away from the railroad tracks.
- In case of prolonged parking, protect the telehandler from bad weather, particularly in the

event of frost (check the antifreeze level), close the rear window, lock the cabin door and the engine cover.

## **⚠ DANGER**

Before leaving the driver's seat, make sure you have carried out all the stopping operations of the telehandler correctly.

1. Park the telehandler on level ground or with a slope of less than 15%.
2. Place the reverse gear lever in idlesoff.
3. Apply the parking brake.
4. Fully retract the boom.
5. Place the forks or the attachment on the ground.
6. Switch off the three-phase motor.
7. Remove the ignition key.
8. Check that the door is locked and that the rear window and engine cover are also closed.

### **1.4.6 DRIVING THE TELEHANDLER ON THE ROAD**

- Drivers of forklifts traveling on the road must comply with the general regulations relating to road traffic.
- The telehandler must comply with the traffic regulations of your country.

## **⚠ DANGER**

The transport of loads by road is prohibited and the attachments mounted on the telehandler must be equipped with the required equipment or be disassembled.

## **⚠ DANGER**

The vehicle can travel on public roads only empty, i.e. unladen.

Transportation of people is prohibited.

1. Verify that the flashing lights are installed and functioning.
2. Always fasten and adjust the seat belt.
3. Close the door.
4. Dipped beam headlights also on during the hours and in the streets where the use of visual signaling and lighting devices is not required.
5. Check the correct operation and cleanliness of the headlights, indicator lights and windscreen wipers.

6. Check the position of the rear view mirrors.
7. Check wheel alignment and push the steering selector to the drive position with front steering wheels only.
8. Make sure there is enough fuel.
9. Fit all the attachments required for road traffic (according to model and country).
10. Put the boom in the transport position, i.e. boom retracted and 300 mm (11.8 in) above the ground.
11. Level the machine with the chassis parallel to the ground using the tilt corrector.
12. Raise and retract the stabilizers as far as possible.
13. The vehicle can travel on public roads only empty, i.e. unladen.

## **1.5. HANDLING INSTRUCTIONS**

### **1.5.1 HANDLING INSTRUCTIONS**

- Check the conformity of the attachments with the calibration of the safety system of the machine.
- Check the proper functioning of the telehandler attachments.
- Do not perform operations that exceed the capabilities of the telehandler or attachment.
- It is forbidden to increase the counterweight value whatever the artifice used.
- It is strictly forbidden to transport or lift people with the telehandler, unless it is equipped for this purpose and provided with the certificate of conformity relating to lifting people.
- Avoid making long journeys in reverse.
- Carry out slow and progressive maneuvers to raise and lower the telescopic boom (even without load).

## **NOTICE**

The machine with rotated turret, telescopic boom extended and raised over 3 m does not translate.

- Check that the attachment is correctly installed and locked on its holder.
- Verify that you have set the safety system in the cabin in accordance with the attachment fitted.
- Respect the limits of the attachment load chart.
- Check that the pallets, crates, etc. are in good condition and suitable for the load to be lifted.
- Position the forks perpendicular to the load to be lifted, taking into account the position of the center of gravity of the load.

- Never lift a load with only one fork.
- Never lift a sling load with a single fork or with a forks carriage.
- If not used, place the attachment horizontally on the ground (prop up unstable attachments correctly).
- Check that the hydraulic quick couplings of the attachment circuit are clean and protected.

## ⚠ WARNING

Before each change of hydraulic attachment, in order to avoid deterioration of the hydraulic quick couplings it is necessary to:

Before each change of hydraulic attachment, in order to avoid deterioration of the hydraulic quick couplings it is necessary to:

Wait about 1 minute to release the pressure in the hydraulic circuit.

- Verify that there is adequate lighting.
- When lifting a load, be careful that nothing or nobody hinders the correct execution of the operation and avoid any false maneuvers.
- In the case of work carried out near overhead power lines, make sure that the safety distance between the working area of the telehandler and the power line is sufficient.

## ⚠ DANGER

You risk being electrocuted or seriously injured if you work or park the telehandler too close to electrical cables.

We strongly advise you to make sure that the safety rules applied on the site comply with local regulations in force regarding all types of work carried out in the vicinity of power lines.

- Forbid anyone to approach the maneuvering area of the telehandler or to pass under a load.

## ⚠ DANGER

For use on sloping ground, before raising the boom, check that the ground is level.

Telehandlers equipped with level corrector and/or stabilizers can operate on transverse slopes, provided that this inclination is corrected.

- Check that the scaffolding, the loading surface or the stack can support the load.
- Make sure of the stability and compactness of the ground before placing the load.

- Movements on longitudinal slopes:
  - Advance and brake smoothly.
  - Unladen movement: The forks or attachment facing downstream.

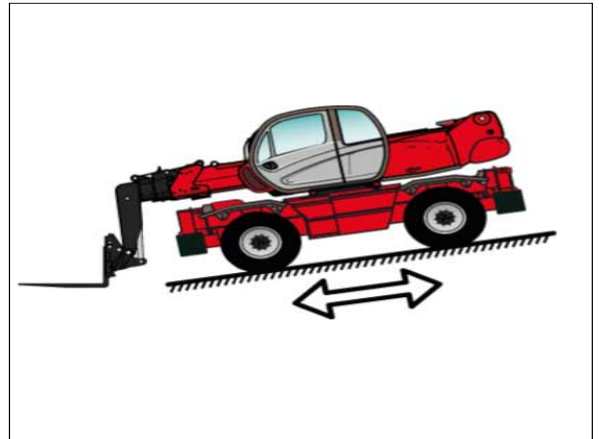

Figure 1:

- Laden movement: The forks or attachment facing upstream.

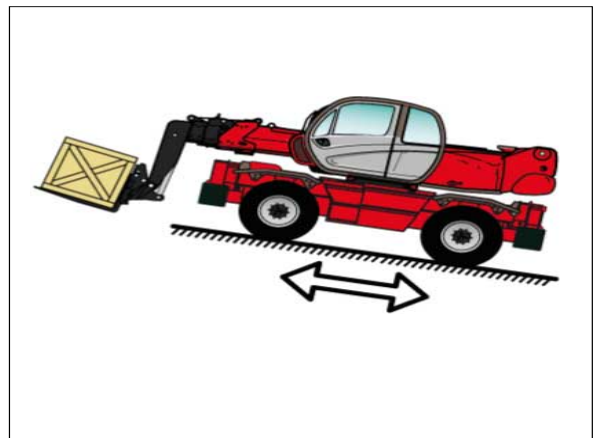

Figure 2:

## ⚠ DANGER

Always observe the safety rules, always carry loads balanced and correctly arranged to avoid any risk of overturning.

1. Fully insert the forks under the load and move it to transport position (forks 300 mm from the ground, boom fully retracted and forks tilted back).
2. For obvious reasons of telehandler stability and good visibility, move the telehandler only when the boom is in the transport position.
3. Only operate the telehandler with the boom raised in exceptional cases; then operate with extreme caution, at very low speed and braking very gently.

4. Make sure you always have sufficient visibility, possibly be guided by another person.
5. Keep the load stable when the telehandler is in motion.
6. Never advance too fast or brake sharply with a load.
7. During handling operations, drive at reduced speed.
8. Monitor the load, especially when cornering, especially if it is bulky.
9. Sling unstable loads.
10. Handle loads carefully, at low speed and without jerks, especially when you take them to great heights and with considerable overhang.
11. In case of strong wind or storm, do not carry out movements that are potentially dangerous for the stability of the telehandler and the load, do not change direction abruptly and at high speed.
12. Use the parking brake to place or lift a difficult load or on sloping ground.
13. Never leave the forklift stationary with a lifted load.
14. Do not leave the telehandler, laden or empty, with the parking brake applied on a slope greater than 15%.
15. Always have good visibility of the route, both in direct vision and in indirect vision, i.e. with panoramic rear view mirrors, to check for the possible presence of people, animals, holes, obstacles, slope variations, etc.
16. Visibility may be reduced on the right side when the boom is raised; therefore make sure that the route is well visible before raising the boom and before maneuvering.
17. If forward visibility is insufficient due to the bulk of the load, drive in reverse. This maneuver has an exceptional character and can only be carried out for short distances.
18. Make sure you have good visibility (clean windows, sufficient lighting, adjusted rear view mirror, etc.).
19. The signaling systems and lights of the telehandler must be suitable for the conditions of use. The standard illumination of the machine is not sufficient for use in low-light environments or for use at night.

## ⚠ DANGER

If the telehandler overturns, do not attempt to get out of the cabin during the accident.

Always drive with seat belts fastened. Being seated in the cabin is your best protection.

## 1.6. HANDLING OF A LOAD

### 1.6.1 LOAD WEIGHT AND CENTER OF GRAVITY

#### ⚠ WARNING

It is forbidden to lift and transport a load greater than the rated capacity of the telehandler or attachment.

- Before lifting a load, you need to know its weight and center of gravity.
- The load chart for your telehandler is valid for a load whose center of gravity is 500 mm from the heel of the forks.

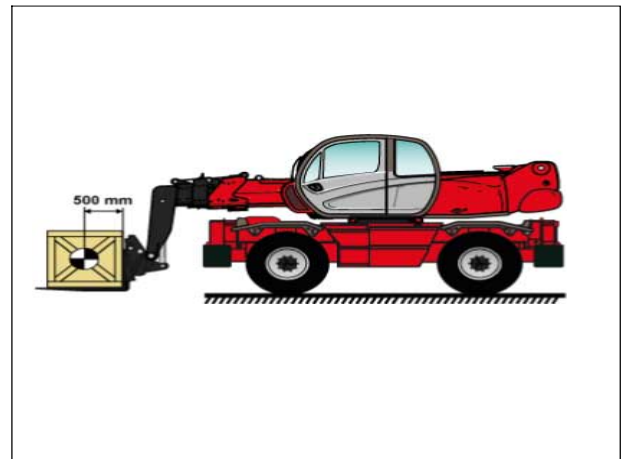

Figure 3:

- For uneven loads, determine the center of gravity in the transverse direction before each movement.

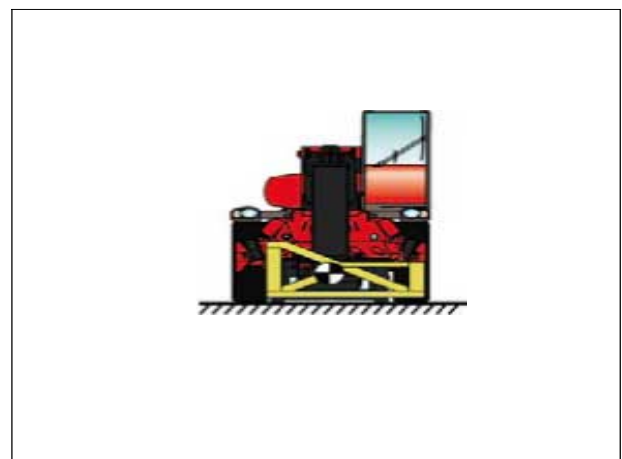

Figure 4:

## ⚠ WARNING

For loads with a mobile center of gravity (for example: liquids), it is necessary to take into account the variations in the center of gravity to determine the load to be handled and to pay particular attention and prudence in order to limit these variations to the maximum.

### 1.6.2 PICKING UP A LOAD FROM THE GROUND

1. Move the telehandler perpendicular to the load, with the boom retracted and the forks horizontal.

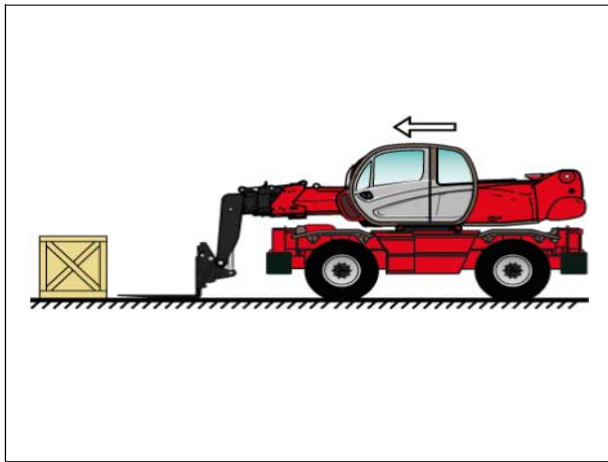

Figure 5:

- 2.

## ⚠ WARNING

Beware of the risk of pinching or crushing of limbs during manual adjustments of the forks.

Always maintain an equal distance between the forks and the central axis of the forks carriage to ensure perfect stability of the load.

Adjust the offset and centering of the forks with respect to the load.

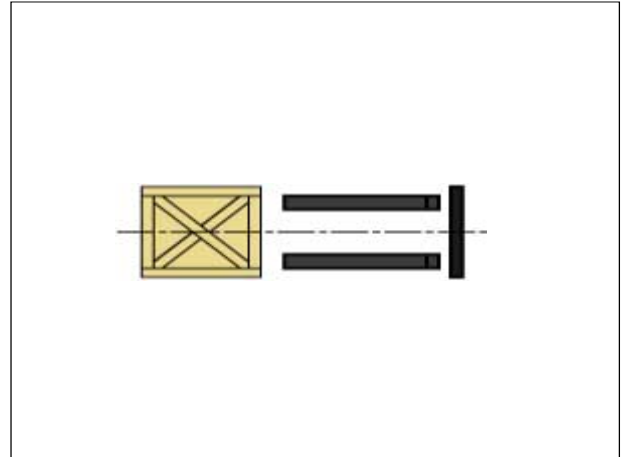

Figure 6:

3. - Slowly advance the telescopic handler (1), and move the forks against the load, if you need to raise the boom (2) slightly when picking up the load.

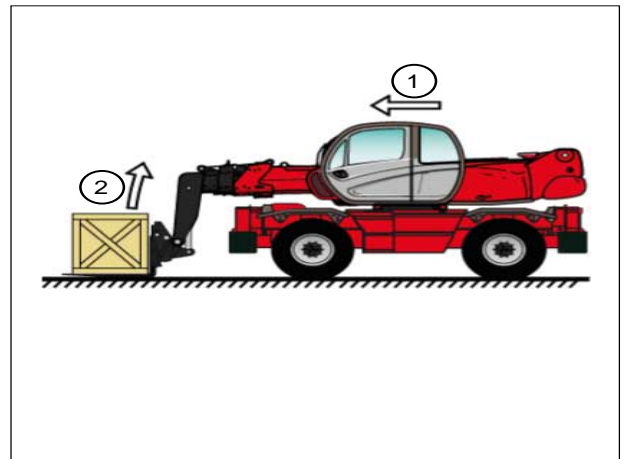

Figure 7:

4. Apply the parking brake and place the reverse lever in idleoff.

- Slightly raise the load (1), tilt the forks carriage (2) back into transport position.

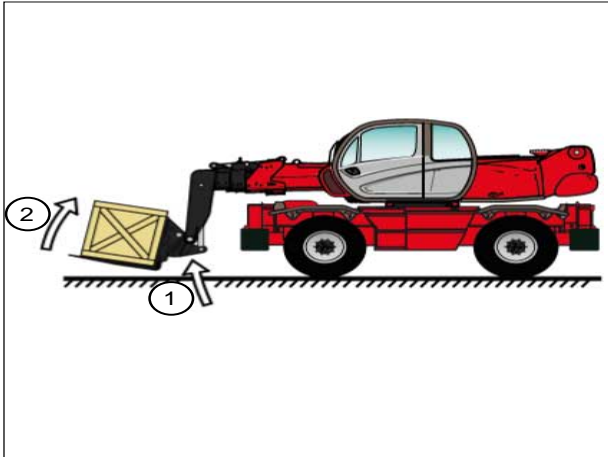

Figure 8:

### ⚠ WARNING

Tilt the load sufficiently backwards to ensure stability (loss of load during braking), but be careful not to change its balance.

### 1.6.3 PICK UP A LOAD UP ON TIRES

### ⚠ WARNING

It is strictly forbidden to pick up a load if the telehandler is not level

- Check that the forks pass easily under the load.
- Move the telehandler perpendicular to the load with the horizontal forks, maneuvering gently and carefully.

### ⚠ WARNING

Remembering to always keep the distance necessary to insert the forks under the load, between the stack and the telehandler, using the minimum possible length of the boom.

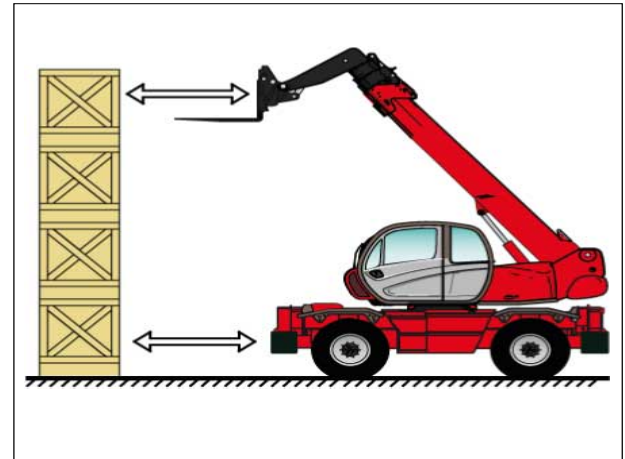

Figure 9:

- Bring the forks against the load. Apply the parking brake and place the reverse lever in idleoff.

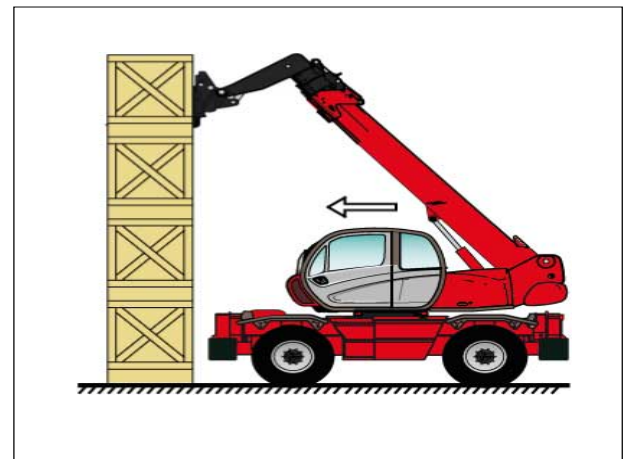

Figure 10:

- Slightly lift the load (1) and tilt the forks carriage (2) back to stabilize the load

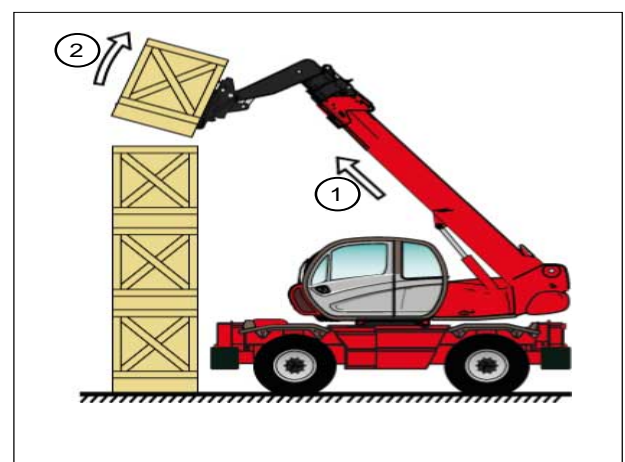

Figure 11:

-

## ⚠ WARNING

Tilt the load sufficiently backwards to ensure stability (loss of load during braking), but be careful not to change its balance.

If possible, lower the load without moving the telehandler.

- 5.1. Raise the boom (1) to remove the load,
- 5.2. retract (2) and lower the boom (3) to bring the load into transport position.

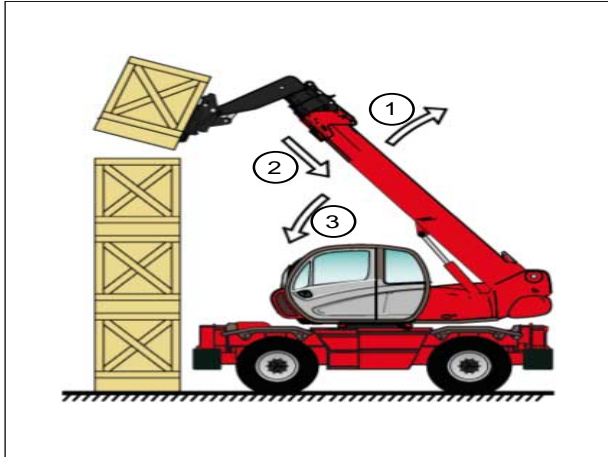

Figure 12:

6. If this is not possible, move the telehandler back.
  - 6.1. Maneuvering very gently and with extreme caution, move the telehandler (1) back to remove the load,
  - 6.2. retract (2) and lower the boom (3) to bring the load into transport position.

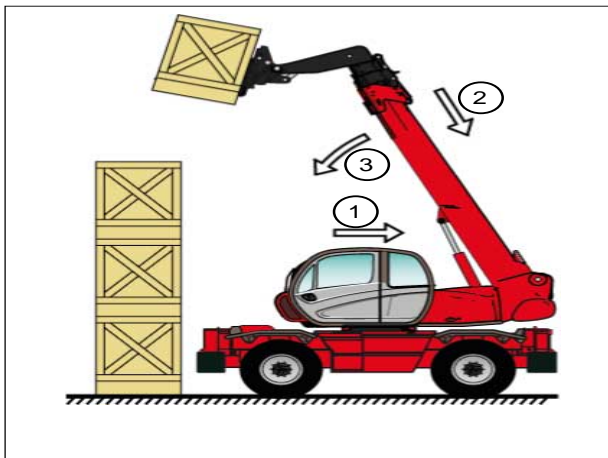

Figure 13:

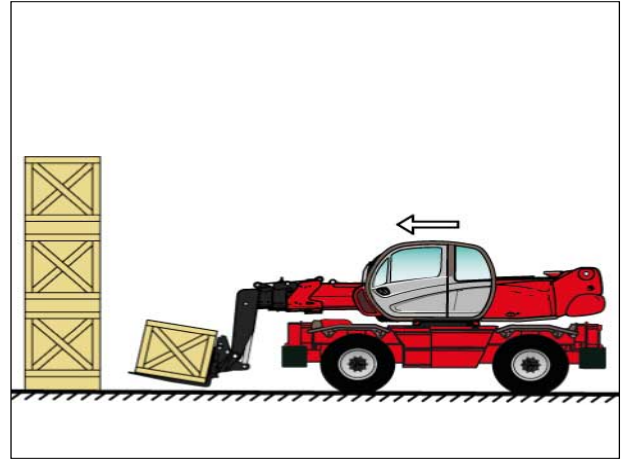

Figure 14: Load in transport position

### 1.6.4 PICKING UP A LOAD WITHOUT A PALLET

1. Tilt the forks (1) forward and extend the boom (2) while at the same time tilting the forks (3) back to insert the forks under the load. If necessary, stop the load with a wedge.

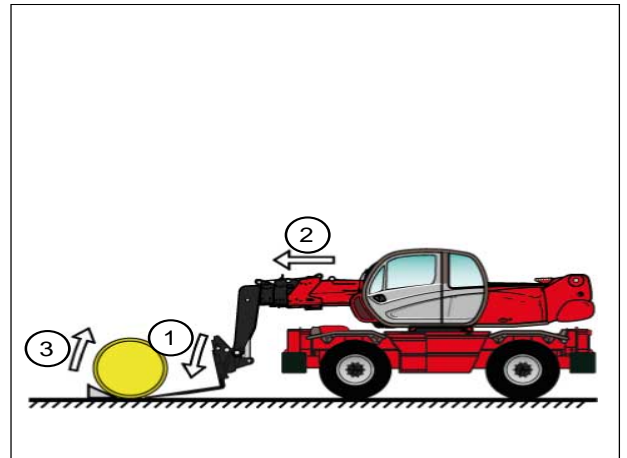

Figure 15:

### 1.6.5 LOAD STATUS INDICATOR DEVICE

1. Always observe the load status indicator during handling.

## 1.7. INSTRUCTIONS FOR USING THE RADIO CONTROL

### 1.7.1 RECOMMENDATIONS FOR USING THE REMOTE CONTROL

#### Compliance

Each remote control complies with Directive 1999/5 / EC (RTTE) and its essential requirements. Each remote control also complies with the harmonized standards reported in the EC declaration of conformity.

#### Radioelectric connection

The two units communicate with each other continuously via a radio link. This is a necessary requirement to ensure the safety of the remote controlled machine. The units encode messages using an address stored in the S-KEY and in the code key present in the connector of the receiving unit. This address is unique, univocal (specific for each remote control) and not reproducible. Each unit can only decode messages from the unit that has the same address. This excludes that a message from another radio device activates any system function.

The units send each other the coded messages:

- those sent by the transmitting unit contain the operating commands that will be implemented by the machine;
- those sent by the receiving unit contain useful information for the automatic management of the working frequency and information regarding the measurements carried out on the machine (Data Feedback function).

#### Frequencies

The radio connection between the remote control units takes place at one of the frequencies permitted by the regulations in force at the time of placing on the market.

#### Safety functions

The remote controls are equipped with some functions that provide a high level of safety in order to preserve the safety of people and things.

#### Stopping function

The stop function brings the machine to a safe state whenever it needs to be stopped due to a potentially dangerous situation. Depending on the case, this function is activated voluntarily by the operator (active stop) or intervenes automatically and autonomously (passive stop).

#### Active stopping

Active stopping is a function activated by the STOP button. The transmitting unit sends a command to the receiving unit to stop the machine immediately. Stopping the machine using the STOP button takes place in a shorter time than that obtained through the passive stop.

#### Passive stopping

Passive stopping is a function that intervenes as a consequence of an anomalous situation that occurs during operation. When the radio connection is incorrect or interrupted, the receiving unit decides autonomously to stop the radio control. Protection from unwanted movements from the UMFS rest position. This safety function protects the "machine + remote control" system from unwanted movements, understood as machine movements not activated voluntarily by the operator, but caused by any electrical and mechanical failures of the radio control. This protection controls the neutral (rest) position of the actuators that control the movements in the machine. Whenever one of these actuators is operated, the transmitting unit sends both the motion command and the command.

#### SAFETY

Depending on the application, the outputs relating to these commands are wired in series or the outputs of the SAFETY command pilot the safety device provided on the machine.

## ⚠ WARNING

In addition to all the indications imposed by the manufacturer of the machine, by the installer of the remote control and by the person in charge of safety in the work area, an operator must always respect the following warnings:

The transmitter unit must be used in an easy and comfortable way, preventing it from falling accidentally. The strap supplied with the remote control serves this purpose.

Put yourself in a position that allows direct control of the remote controlled machine and of the movements of the load, as well as in a position that guarantees its safety conditions with respect to other operations and/or activities and/or processes that take place in the workplace .

Never start up or use the transmitter unit in work situations in which you may lose your balance or trip.

Always check the correct mechanical functioning of the STOP button. If it is impossible or difficult to operate this button, do not use the remote control.

Never start the transmitter unit except to start working: improper use could cause dangerous situations.

Never start or operate the transmitter unit in closed places, out of sight or out of the range of action typical of the radio control: even in these cases it is possible to create a radio connection with the risk of making the remote controlled machine execute unwanted commands.

During normal operation, follow all the movements of the machine and of the load by direct visual control while remaining within the operating range of the remote control.

Pay attention to visual and acoustic warnings and signals and take all precautions and actions necessary to prevent the movement of the remote controlled machine from creating dangerous situations for people and/or things.

Pay attention to the entire work area and intervene immediately by pressing the STOP button when a dangerous situation arises.

Avoid touching the metal part of the receiving unit as it could reach high and potentially dangerous temperatures.

In case of malfunction, shut down the "machine + remote control" system until the problem is completely eliminated.

After using the remote control, turn off the transmitter unit when suspending or temporarily interrupting work, avoiding leaving the load suspended (even when replacing the discharged battery).

Never leave the transmitter unit unattended with the S-KEY inserted.

Always store the S-KEY in a safe place whenever it is removed from the transmitter unit.

If this key is lost, it is impossible to operate the remote control as the transmitting unit needs the address stored in the key to work with the relative receiving unit.

## ⚠ WARNING

### Remote control life cycle

To ensure safe and long-lasting use of the remote control, it is necessary to carefully follow the instructions relating to each phase of the product's life:

- transport: a remote control must be transported and kept in its original packaging until it is installed on the machine.
- installation: the installation and testing of the remote control must be carried out exclusively by qualified personnel, possessing the necessary technical knowledge to carry out these operations and qualified according to the provisions of the country in which the assembly is carried out.

Only a correct installation can ensure a safe use of the remote control.

Usage:

a radio remote control must be used by qualified and adequately trained personnel.

Radio remote control maintenance:

the following instructions provide information to safely carry out routine and extraordinary maintenance operations on the remote control:

- routine maintenance is the operation or set of operations necessary to maintain the normal conditions of use of the remote control through set-up, verification, scheduled replacement of the parts, which are made necessary by normal use of the remote control.
- Extraordinary maintenance is the operation or set of repair operations necessary for breakdowns, breakages or malfunctions of the remote control, which have the purpose of restoring the original conditions of use and operation.

Before calling in the service technicians of the machine manufacturer, it is advisable:

- to have read and understood this manual in all its parts, checking that all the instructions contained therein have been correctly carried out
- to have followed the instructions to search for possible malfunctions and their causes.

Any faults can only be repaired by authorized personnel, contact the MANITOU assistance service.

To make a faster and more effective intervention possible, the data for a correct and complete identification of the remote control must be communicated:

1. serial number (S/N) of the remote control and the TU ID (identification number of the transmitter unit)
2. date of purchase (shown on the certificate of warranty)
3. anomaly found
4. address and telephone number of the place where it is used

All remote control set-up and maintenance interventions must be checked and recorded by the machine maintenance manager.

In case of breakdown, emergency, or damaged parts, the "machine + remote control" system must be put out of service until the problem is completely eliminated.

Before any maintenance operation, remove the transmitter unit battery and the receiver unit power supply.

After each maintenance operation, always check that the commands sent by the transmitting unit only activate the planned maneuvers.

#### **Scrapping of the remote control.**

For scrapping, entrust the remote control to the differentiated scrap recovery service existing in the area.

In particular, be careful when recycling batteries by applying local regulations.

Do not dispose of them with household waste.

#### **General operating instructions**

##### **Starting the remote control.**

The start-up of the remote control consists in establishing the radio connection between the transmitter and receiver units. To achieve this, it is necessary:

- to power the receiving unit respecting the voltage limits indicated in the technical data. The POWER LED lights up,
- insert a fully charged battery in the transmitter unit,
- insert the S-KEY in the transmitter unit
- press the START button on the transmitter unit until the POWER LED on the receiver unit and the green LED on the transmitter unit start flashing slowly.

##### **Activation of commands**

With the remote control started, it is possible to operate the joysticks, buttons and selectors relating to the command to be carried out.

To know the correspondence between the actuators and the operations of the machine, the operator must be adequately trained regarding the symbols present on the panel of the transmitting unit.

##### **Data Feedback function**

The Data Feedback function makes the information and/or signals regarding the machine he is controlling available to the operator.

During normal operation of the remote control, pay attention to the indications displayed and signaled by the display or by the LEDs: they are an aid in assessing the operating situation in which the machine is located.

When operating and controlling the machine, consider that the remote control does not intervene autonomously in the potential danger situations displayed and signaled.

##### **Operation with display**

If there is a display in the transmitting unit, the signaling icons, the values of the measurements carried out in the machine and their descriptions can be displayed.

##### **Operation with LEDs.**

If there are LEDs in the transmitter unit, when they turn on, it indicates particular conditions of the machine.

Interruption of the radio connection.

When the radio connection is incorrect or interrupted for a certain time, the passive stopping function intervenes.

The green LED of the transmitter unit changes from slow to fast flashing.

The POWER LED of the receiving unit changes from flashing to steady on.

To start the remote control, press the START button.

Automatic switching off of the transmitter unit.

The automatic switching off of the transmitting unit occurs when:

- the battery is flat, the remote control is not used for a set time,
- the transmitting unit remains powered for eight hours without ever being turned off.
- The green LED of the transmitter unit goes out.
- The POWER LED of the receiving unit changes from flashing to steady on.
- To start the remote control, press the START button.

##### **Low battery**

The transmitter unit signals if the battery is not sufficiently charged (the red LED flashes accompanied by an acoustic signal). After 3.5 minutes from the start of the signal, the transmitting unit switches off automatically. You need to replace the battery with a charged one.

##### **Non-use of the transmitter unit**

If the transmitting unit remains on for a time equal to the "auto-off time" without the commands being activated, it switches off automatically.

##### **Continuous use**

The transmitter unit signals if it has never been switched off after eight hours (the red LED flashes accompanied by an acoustic signal). After 3.5 minutes from the start of the signal, the transmitting unit switches off automatically.

##### **Switching off of the transmitter unit**

The transmitter unit must be switched off every time work is suspended: remove the S-KEY and always put it in a safe place.

#### Switching off the receiver unit

The receiver unit must be switched off every time the remote control is not used to control the machine. To turn off the unit, it is necessary to disconnect the power supply.

## 1.8. TRANSLATION OF THE VEHICLE BY RADIO CONTROL

### 1.8.1 TRANSLATION OF THE TELEHANDLER BY REMOTE CONTROL OR PLATFORM (OPTIONAL)

The telehandler can be equipped with a remote control or wire control (radio control positioned on the platform) which allows the translation (movement) of the vehicle remotely or from the platform (basket).

The remote control is equipped with an additional joystick to control the translation of the vehicle in both directions of travel and the steering of the wheels. In addition, on the remote control there are commands that allow the choice of the type of steering (road circulation, lateral movement or reduced turning radius) and the commands to activate the stabilizers.

The movement of the vehicle controlled by remote control must be used ONLY to position the telehandler in a new work area adjacent to the previous one.

Each translation movement must be confirmed by the operator using the "Driving function consent button" located on the left side of the remote control.

### **⚠ DANGER**

During remote controlled travel, the vehicle speed is reduced to 3 km/h and the hydraulic movements are deactivated.

### 1.8.2 SAFETY REQUIREMENTS FOR TRANSLATION BY REMOTE CONTROL

When moving the vehicle controlled by remote control, in addition to the safety requirements already described for driving the telehandler, the safety requirements listed below must be respected.

- The operator must:
  - make sure that the remote control is working and the battery is charged,
  - make sure that the stabilizers are raised and fully retracted,

- make sure that the turret is centered or rotated by a maximum of 3°,
- make sure that there are no people in the working area of the machine,
- make sure there are no people in the cabin,
- ensure that within a radius of 15 m (49.2 ft) from the vehicle there are no obstacles, dips, descents or climbs that affect the stability of the vehicle,
- always have good visibility of the course to check for the possible presence of people, animals, holes, obstacles, slope variations, etc.,
- follow the vehicle during translation, walking at a safe distance sufficient not to interfere with the range of action of the machine,
- never position himself in the direction of travel of the vehicle,
- make every movement very carefully, avoiding sudden slowdowns.
- Translation is allowed:
  - for short distances in transport position, i.e. boom retracted and 300 mm (11.8 in) above the ground,
  - to position the vehicle in a new work area adjacent to the previous one.
- During the translation it is forbidden to:
  - rotate the turret,
  - lower the stabilizers,
  - raise or extend the telescopic boom,
  - tilt the attachment,
  - operate the attachment hydraulically,
  - lose eye contact with the vehicle,
  - move away from the vehicle beyond 10 m (33 ft),
  - move away from the vehicle until it is completely stationary,
  - go up or down slopes with a gradient of more than 3°,
  - drive up or down slopes with a transversal slope greater than 3°,
  - make turns in narrow and sloping spaces,
  - run along public or private roads if they are not closed to traffic or the public or are not part of the construction site.

### 1.8.3 PLATFORM TRANSFER SAFETY REQUIREMENTS (BASKET)

When moving the vehicle controlled by wire control (remote control positioned on the platform), in addition to the safety requirements already described for driving

the telehandler, the safety requirements listed below must be respected.

- The operator must:
  - wear the fall arrest harness,
  - make sure the safety rope or restraint devices are firmly anchored to the platform,
  - make sure that the control station is functional,
  - make sure that the stabilizers are raised and fully retracted,
  - make sure that the turret is centered or rotated by a maximum of 3°,
  - make sure that the platform is perpendicular to the boom (i.e. not rotated),
  - make sure that there are no people in the working area of the machine,
  - make sure there are no people in the cabin,
  - ensure that within a radius of 15 m (49.2 ft) from the vehicle there are no obstacles, dips, descents or climbs that affect the stability of the vehicle,
  - always have good visibility of the course to check for the possible presence of people, animals, holes, obstacles, slope variations, etc.,
  - make every movement very carefully, avoiding sudden slowdowns.
- Translation is allowed:
  - for short stretches, with the number of permitted operators indicated for the platform in use,
  - in transport position, i.e. with boom retracted and at 300 mm (11.8 in) from the ground,
  - to position the vehicle in a new work area adjacent to the previous one.
- During the translation it is forbidden to:
  - rotate the turret,
  - lower the stabilizers,
  - raise or extend the telescopic boom,
  - tilt the platform,
  - rotate the basket,
  - go up or down slopes with a gradient of more than 3°,
  - drive up or down slopes with a transversal slope greater than 3°,
  - make turns in narrow and sloping spaces,
  - reverse stretches without the help of ground staff to assist with the maneuver,
  - run along public or private roads if they are not closed to traffic or the public or are not part of the construction site,

- step off the platform until the vehicle is completely stopped.

## ⚠ DANGER

During the translation from the platform, pay attention to the dimensions of the platform which could be even greater than that of the vehicle.

## 1.9. TELEHANDLER MAINTENANCE INSTRUCTIONS

### 1.9.1 RECOMMENDATIONS FOR MAINTENANCE

Before carrying out any routine or extraordinary maintenance on the telehandler, follow the instructions below.

## ⚠ WARNING

The vehicle is equipped with three ladders (front, rear and right side) that allow access to the walkable surface above the vehicle's undercarriage. The latter must only be used during maintenance operations and only to access the walkable surface.

It is not allowed to use the front, rear or right side ladder to access the vehicle cabin.

1. Read carefully and understand the instruction manual.
2. Switch off the three-phase motor before any intervention on the telehandler.
3. Wear appropriate clothing for the maintenance operations of the telehandler, avoiding jewelry and clothing that is too loose. If necessary, tie and protect the hair.
4. Make sure that the room is sufficiently ventilated before starting the telehandler.
5. Make any necessary repairs, even minor ones, immediately.

## NOTICE

Pay particular attention to the disposal of consumables and used parts, making sure that it is carried out in maximum safety and in an eco-friendly way.

6. Repair any leaks, even the smallest ones, immediately.

7. Do not try to loosen fittings, hoses or a hydraulic component with the circuit under pressure.

**⚠ WARNING**

The modification of the adjustment and the disassembly of the counterbalance valves or of the safety valves which, at times, equip the jacks of the telehandler can be dangerous.

A counterbalance valve can only be removed with the concerned jack at rest and with the hydraulic circuit without pressure. This operation can only be carried out by authorized personnel.

---

8. Do not smoke or approach the telehandler with open flames when the fuel tank is open or filling.
9. Pay attention to the risk of burns (fume treatment system, hood, radiator, three-phase motor, etc.).
10. Disconnect the negative pole (-) from the battery before working on the electrical system.
11. Do not place metal pieces on the battery.
12. To carry out an electric welding on the telehandler, place the clamp of the negative cable of the welding machine directly on the piece to be welded in order to prevent very strong current from flowing through the alternator.

## 2. TECHNICAL DATA AND DESCRIPTION

### 2.1. MACHINE IDENTIFICATION

#### 2.1.1 IDENTIFICATION OF THE ROTATING TELESCOPIC HANDLER

In order to make constant improvements to our products, some changes can be made to our range of telescopic handlers, without any obligation to inform our customers on our part.

For each spare part order or for each request for technical information, it is necessary to specify the following information.



In order to communicate all the numbers more easily, it is recommended to write them in the appropriate spaces upon delivery of the rotating telehandler

#### 2.1.2 IDENTIFICATION OF THE ROTATING TELESCOPIC HANDLER

#### MANUFACTURER'S PLATE

Figure 16: Manufacturer's Plate of the Rotary Telehandler

Table 1. Manufacturer's Plate of the Rotary Telehandler

| Ref. | Description                                |  |
|------|--|--|
| 1    | Model                                      |  |
| 2    | Series                                     |  |
| 3    | Year of manufacture                        |  |
| 4    | Year model                                 |  |
| 5    | Serial No.                                 |  |
| 6    | Unladen mass                               |  |
| 7    | Power ISO / TR 14396                       |  |
| 8    | Total Permitted Working Weight             |  |
| 9    | Nominal capacity                           |  |
| 10   | Maximum lift capacity (on the towing hook) |  |
| 11   | Drawbar pull                               |  |

#### 2.1.3 HEAT ENGINE PLATE

Figure 17: Heat engine plate

Table 2. Heat engine plate

|   |               |  |
|---|---------------|--|
| 1 | Model         |  |
| 2 | Displacement  |  |
| 3 | Engine number |  |

## 2.1.4 HYDROSTATIC PUMP PLATE

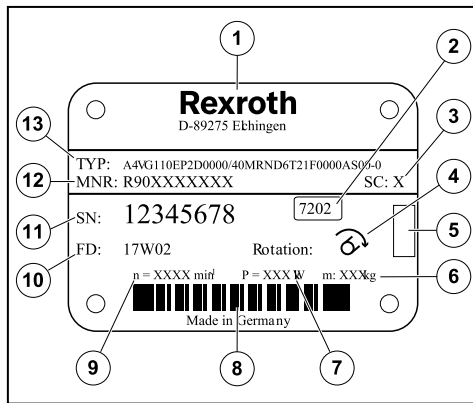

Figure 18: Hydrostatic pump plate

Table 3. Hydrostatic pump plate

|    |   |  |
|----|---|--|
| 1  | Manufacturer  |  |
| 2  | Indoor plant designation  |  |
| 3  | Category (optional)   |  |
| 4  | Direction of rotation (seen on the motor shaft) - here: clockwise |  |
| 5  | Specific area for inspection marking                              |  |
| 6  | Weight (optional)   |  |
| 7  | Power   |  |
| 8  | Bar code  |  |
| 9  | Rotation speed  |  |
| 10 | Manufacturing date  |  |
| 11 | Serial number   |  |
| 12 | Material code of the axial piston unit                            |  |
| 13 | Ordering code   |  |

## 2.1.5 HYDROSTATIC MOTOR PLATE

## HYDROSTATIC MOTOR PLATE 1

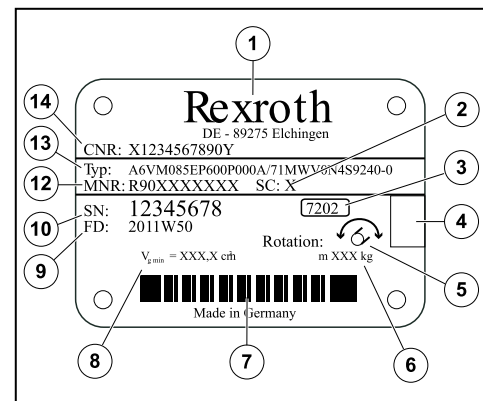

Figure 19: Hydrostatic motor plate 1

Table 4. Hydrostatic motor plate 1

|    |   |  |
|----|---|--|
| 1  | Manufacturer  |  |
| 2  | Indoor plant designation  |  |
| 3  | Category (optional)   |  |
| 4  | Direction of rotation (seen on the motor shaft) - here: clockwise |  |
| 5  | Specific area for inspection marking                              |  |
| 6  | Weight (optional)   |  |
| 7  | Power   |  |
| 8  | Bar code  |  |
| 9  | Rotation speed  |  |
| 10 | Manufacturing date  |  |
| 11 | Serial number   |  |
| 12 | Material code of the axial piston unit                            |  |
| 13 | Ordering code   |  |
| 14 | Customer material number  |  |

## HYDROSTATIC MOTOR PLATE 2

(depending on machine model)

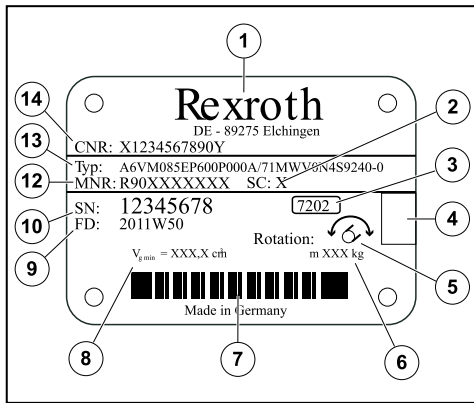

Figure 20: Hydrostatic motor plate 2

Table 5. Hydrostatic motor plate 2

|    |   |  |
|----|---|--|
| 1  | Manufacturer  |  |
| 2  | Indoor plant designation  |  |
| 3  | Category (optional)   |  |
| 4  | Direction of rotation (seen on the motor shaft) - here: clockwise |  |
| 5  | Specific area for inspection marking                              |  |
| 6  | Weight (optional)   |  |
| 7  | Power   |  |
| 8  | Bar code  |  |
| 9  | Rotation speed  |  |
| 10 | Manufacturing date  |  |
| 11 | Serial number   |  |
| 12 | Material code of the axial piston unit                            |  |
| 13 | Ordering code   |  |
| 14 | Customer material number  |  |

### 2.1.6 GEARBOX PLATE

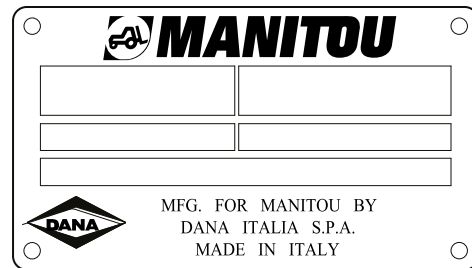

Figure 21: Gearbox plate

Table 6. Gearbox plate

|   |                      |  |
|---|----------------------|--|
| 1 | Group type and model |  |
| 2 | Serial No.           |  |
| 3 | MANITOU Reference    |  |
| 4 | Index of alteration  |  |
| 5 | Lubricant            |  |

### 2.1.7 FRONT AXLE PLATE

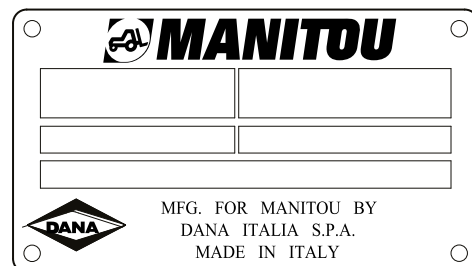

Figure 22: Front axle plate

Table 7. Front axle plate

|   |                      |  |
|---|----------------------|--|
| 1 | Group type and model |  |
| 2 | Serial No.           |  |
| 3 | MANITOU Reference    |  |
| 4 | Index of alteration  |  |
| 5 | Lubricant            |  |

### 2.1.8 REAR AXLE PLATE



Figure 23: Rear axle plate

Table 8. Rear axle plate

|   |                      |  |
|---|----------------------|--|
| 1 | Group type and model |  |
| 2 | Serial No.           |  |
| 3 | MANITOU Reference    |  |
| 4 | Index of alteration  |  |
| 5 | Lubricant            |  |

### 2.1.10 CHASSIS PLATE



Figure 25: Chassis plate

Table 10. Chassis plate

|                                   |  |
|-----------------------------------|--|
| Serial number / Product ID number |  |
|-----------------------------------|--|

### 2.1.9 CABIN PLATE

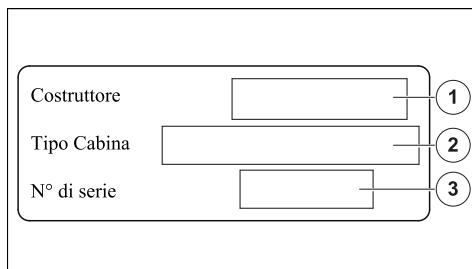

Figure 24: Cabin plate

Table 9. Cabin plate

|   |              |  |
|---|--------------|--|
| 1 | Manufacturer |  |
| 2 | Cabin type   |  |
| 3 | Serial No.   |  |

### 2.1.11 ACCESSORY MANUFACTURER'S PLATE



Figure 26: Accessory manufacturer's plate

Table 11. Accessory manufacturer's plate

|   |                     |  |
|---|---------------------|--|
| 1 | Model               |  |
| 2 | Serial number       |  |
| 3 | Year of manufacture |  |
| 4 | Unladen mass        |  |
| 5 | Center of gravity   |  |
| 6 | Nominal capacity    |  |
| 7 | Service pressure    |  |

## 2.2. TECHNICAL SPECIFICATIONS

### 2.2.3 FEATURES MRT 2570 AND 3060



The specifications provided are not binding on the manufacturer and may be subject to change without prior notice.

Table 32. Capacity (on stabilizers)

| Description  | Unit    | MRT 2570 |       | MRT 3060 |       |
|--|---------|----------|-------|----------|-------|
|  |         | kg       | lb    | kg       | lb    |
| Maximum rated capacity with standard fork carriers and forks | kg - lb | 7000     | 15400 | 6000     | 13200 |
| Standard lifting height                                      | m - ft  | 24.8     | 81.4  | 29.9     | 98    |
| Forward reach with fork-carrier and standard forks           | m - ft  | 20.5     | 67    | 25.7     | 84.3  |

Table 33. Weight and measurements

| Description   | Unit    | Ref. | MRT 2570        |                     | MRT 3060        |                     |
|---|---------|------|-----------------|---------------------|-----------------|---------------------|
|   |         |      |                 |                     |                 |                     |
| Total length (with forks)                                 | m - ft  | l1   | 8.87            | 29.1                | 9.14            | 29.99               |
| Length to the face of the forks                           | m - ft  | l2   | 7.67            | 25.16               | 7.94            | 26.05               |
| Chassis length  | m - ft  | l14  | 5.92            | 19.42               | 5.92            | 19.42               |
| Length from center of rotation to ballast                 | m - ft  | a7   | 3.45            | 11.32               | 3.45            | 11.32               |
| Total length to the stabilizers                           | m - ft  | l12  | 5.62            | 18.44               | 5.62            | 18.44               |
| External turning radius (above the tires)                 | m - ft  | Wa1  | 4.37            | 14.34               | 4.37            | 14.34               |
| Total width with extended stabilizers                     | m - ft  | b7   | 6.06            | 20.28               | 6.06            | 19.88               |
| Ground clearance under the front tires on the stabilizers | m - ft  | m5   | 0.45            | 1.48                | 0.45            | 1.48                |
| Overall width   | m - ft  | b1   | 2.50            | 8.20                | 2.50            | 8.20                |
| Overall height  | m - ft  | h17  | 3.10            | 10.17               | 3.10            | 10.17               |
| Overall cabin width                                       | m - ft  | b4   | 0.96            | 3.15                | 0.96            | 3.15                |
| Ground clearance  | m - ft  | m4   | 0.36            | 1.18                | 0.36            | 1.18                |
| Wheelbase   | m - ft  | y    | 3.25            | 11.06               | 3.25            | 11.06               |
| Tilt-up angle   | °       | a4   | 12              |                     | 12              |                     |
| Tilt-down angle   | °       | a5   | 112             |                     | 112             |                     |
| Chassis leveling correction +/-                           | °       | a9   | 7               |                     | 7               |                     |
| Overall weight  | kg - lb |      | 21300           | 46958.41            | 21800           | 48061.12            |
| Fork section (length / width / section)                   | mm - in |      | 1200 x 125 x 60 | 47.24 x 4.92 x 2.36 | 1200 x 100 x 60 | 47.24 x 3.94 x 2.36 |

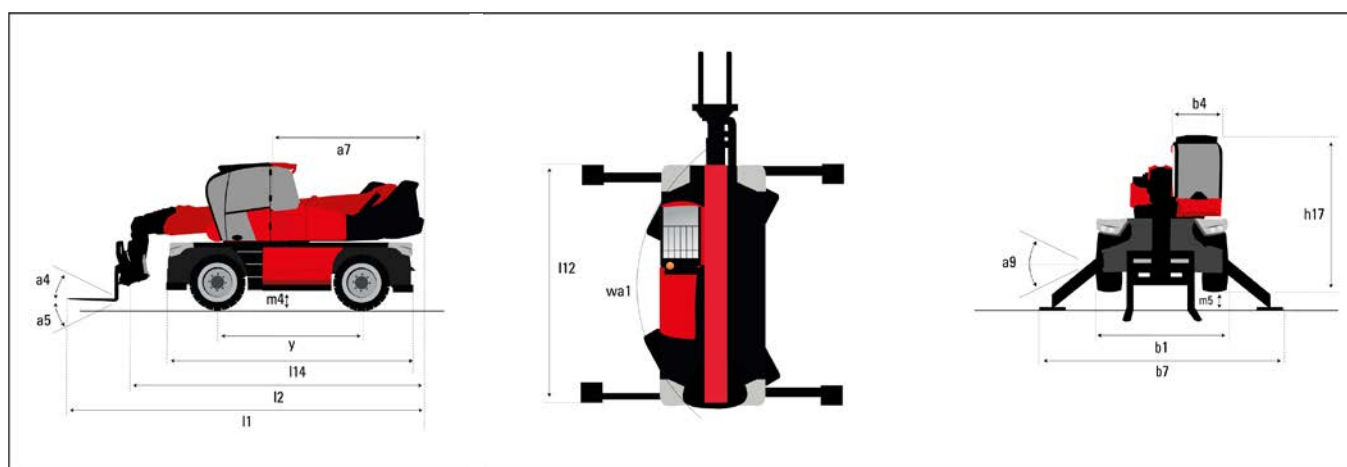

Figure 29: Measurements (side, front and top view)

Table 34. Tires (standard)

| Description                   | MRT 2570  | MRT 3060  |
|-------------------------------|---|---|
| Measurement                   | 445/65 R22.5  | 445/65 R22.5  |
| Driving wheels (front / rear) | 2 / 2   | 2 / 2   |
| Driving modes                 | 2-wheel steer, 4-wheel concentric steer, 4-wheel "crab" steer | 2-wheel steer, 4-wheel concentric steer, 4-wheel "crab" steer |

Table 35. Stabilizers

| Description         | MRT 2570                                       | MRT 3060                                       |
|---------------------|--|--|
| Type of stabilizers | Double telescopic                              | Double telescopic                              |
| Controls            | Individual or simultaneous stabilizer controls | Individual or simultaneous stabilizer controls |

Table 36. Engine

| Description                        | Unit              | MRT 2570                         | MRT 3060                         |
|------------------------------------|-------------------|----------------------------------|----------------------------------|
| Engine brand                       |                   | Yanmar                           | Yanmar                           |
| Engine type (standard)             | Stage / Tier      | EU Stage V / US EPA Tier 4       | EU Stage V / US EPA Tier 4       |
| Engine model                       |                   | 4TN107FTT-6SMU1                  | 4TN107FTT-6SMU1                  |
| Rated power (ISO / TR 14396)       | HP / kW @ rpm     | 173/127 @ 2200                   | 173/127 @ 2200                   |
| Maximum torque                     | Nm @ rpm          | 805 Nm @ 1500                    | 805 Nm @ 1500                    |
| Number of cylinders - Displacement | - cm <sup>3</sup> | 4 - 4567                         | 4 - 4567                         |
| Engine cooling system              |                   | Water cooled                     | Water cooled                     |
| Battery capacity / batteries       |                   | (24V) 2x12V - 120AH - 850 A (EN) | (24V) 2x12V - 120AH - 850 A (EN) |

Table 37. Transmission

| Description                         | Unit      | MRT 2570   | MRT 3060   |
|-------------------------------------|-----------|--|--|
| Type of transmission                |           | Hydrostatic  | Hydrostatic  |
| Number of gears (forward / reverse) |           | Speedshift (2/2)   | Speedshift (2/2)   |
| Maximum travel speed (unladen)      | km / h    | 40   | 40   |
| Drawbar pull (laden)                | daN       | -  | -  |
| Parking brake                       |           | Automatic with negative action                                     | Automatic with negative action                                     |
| Service brake                       | Hydraulic | Multi-disc type in oil bath integrated in the front and rear axles | Multi-disc type in oil bath integrated in the front and rear axles |

Table 38. Hydraulic circuit

| Description            | Unit      | MRT 2570  |         | MRT 3060  |         |
|------------------------|-----------|-----------|---------|-----------|---------|
| Type of hydraulic pump |           | LS pump   |         | LS pump   |         |
| Hydraulic flow         | l / min   | 185 l / m |         | 185 l / m |         |
| Hydraulic pressure     | bar - PSI | 350       | 5076.32 | 350       | 5076.32 |

Table 39. Liquid capacity

| Description                         | Unit       | MRT 2570 |      | MRT 3060 |      |
|-------------------------------------|------------|----------|------|----------|------|
| Motor oil                           | L - US gal | 13       | 2.85 | 13       | 2.85 |
| Hydraulic oil tank and transmission | L - US gal | 300      | 66   | 300      | 66   |
| Fuel tank                           | L - US gal | 320      | 70.4 | 320      | 70.4 |
| DEF (Diesel Emission Fluid) Tank    | L - US gal | 24       |      | 6.34     |      |

Table 40. Noise and vibrations

| Description   | Unit               | MRT 2570 | MRT 3060 |
|---|--------------------|----------|----------|
| Acoustic pressure in the driver's cabin LpA<br>(according to NF EN 12053)   | dB (A)             | -        | -        |
| Guaranteed noise level in the environment LwA<br>(according to Directive 2000/14 / EC modified by Directive 2005/88 / EC) | dB (A)             | -        | -        |
| The weighted average acceleration transmitted to the boom system/ driver's hand<br>(according to ISO 5349-2)              | m / s <sup>2</sup> | -        | -        |

Table 41. Miscellaneous

| Description                            | MRT 2570              | MRT 3060              |
|--|-----------------------|-----------------------|
| Driving wheels (front / rear)          | 2 / 2                 | 2 / 2                 |
| Controls                               | 2 Joysticks           | 2 Joysticks           |
| Safety cabin approval                  | ROPS / FOPS (Level 2) | ROPS / FOPS (Level 2) |
| Attachment recognition system (E-Reco) | E-Reco                | E-Reco                |

## 2.2.4 FEATURES MRT-X 2570 AND 3060



The specifications provided are not binding on the manufacturer and may be subject to change without prior notice.

Table 42. Capacity (on stabilizers)

| Description  | Unit    | MRT-X 2570 |       | MRT-X 3060 |       |
|--|---------|------------|-------|------------|-------|
| Maximum rated capacity with standard fork carriers and forks | kg - lb | 7000       | 15400 | 6000       | 13200 |
| Standard lifting height                                      | m - ft  | 24.8       | 81.4  | 29.9       | 98    |
| Forward reach with fork-carrier and standard forks           | m - ft  | 20.5       | 67    | 25.7       | 84.3  |

Table 43. Weight and measurements

| Description                               | Unit   | Ref. | MRT-X 2570 |       | MRT-X 3060 |       |
|---|--------|------|------------|-------|------------|-------|
| Total length (with forks)                 | m - ft | l1   | 8.87       | 29.1  | 9.14       | 29.99 |
| Length to the face of the forks           | m - ft | l2   | 7.67       | 25.16 | 7.94       | 26.05 |
| Chassis length                            | m - ft | l14  | 5.92       | 19.42 | 5.92       | 19.42 |
| Length from center of rotation to ballast | m - ft | a7   | 3.45       | 11.32 | 3.45       | 11.32 |
| Total length to the stabilizers           | m - ft | l12  | 5.62       | 18.44 | 5.62       | 18.44 |

| Description   | Unit    | Ref. | MRT-X 2570      |                     | MRT-X 3060      |                     |
|---|---------|------|-----------------|---------------------|-----------------|---------------------|
| External turning radius (above the tires)                 | m - ft  | Wa1  | 4.37            | 14.34               | 4.37            | 14.34               |
| Total width with extended stabilizers                     | m - ft  | b7   | 6.06            | 20.28               | 6.06            | 19.88               |
| Ground clearance under the front tires on the stabilizers | m - ft  | m5   | 0.45            | 1.48                | 0.45            | 1.48                |
| Overall width   | m - ft  | b1   | 2.50            | 8.20                | 2.50            | 8.20                |
| Overall height  | m - ft  | h17  | 3.10            | 10.17               | 3.10            | 10.17               |
| Overall cabin width                                       | m - ft  | b4   | 0.96            | 3.15                | 0.96            | 3.15                |
| Ground clearance  | m - ft  | m4   | 0.36            | 1.18                | 0.36            | 1.18                |
| Wheelbase   | m - ft  | y    | 3.25            | 11.06               | 3.25            | 11.06               |
| Tilt-up angle   | °       | a4   | 12              |                     | 12              |                     |
| Tilt-down angle   | °       | a5   | 112             |                     | 112             |                     |
| Chassis leveling correction +/-                           | °       | a9   | 7               |                     | 7               |                     |
| Overall weight  | kg - lb |      | 21300           | 46958.41            | 21800           | 48061.12            |
| Fork section (length / width / section)                   | mm - in |      | 1200 x 125 x 60 | 47.24 x 4.92 x 2.36 | 1200 x 100 x 60 | 47.24 x 3.94 x 2.36 |

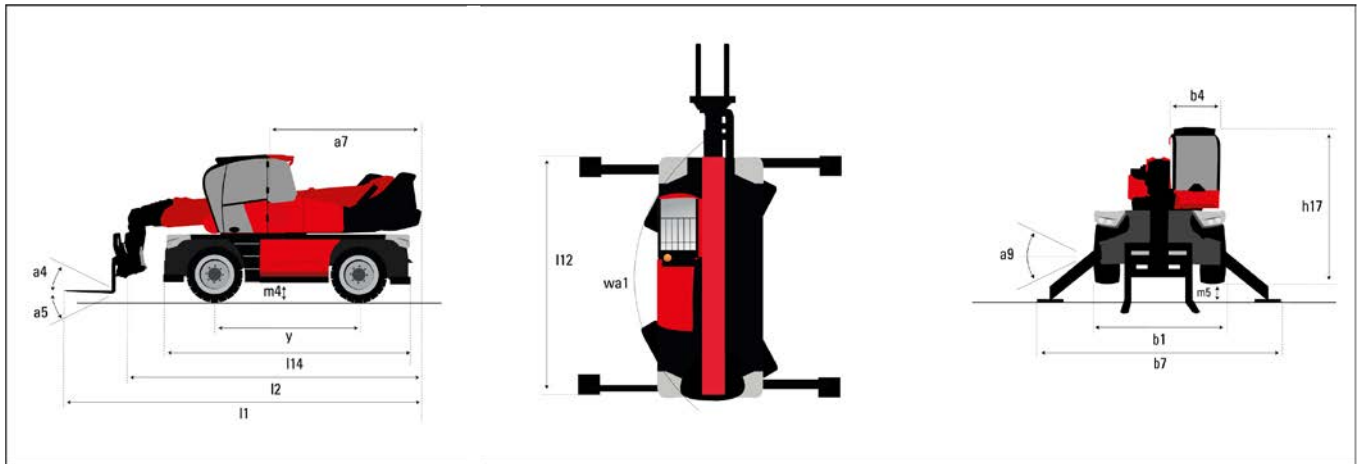

Figure 30: Measurements (side, front and top view)

Table 44. Tires (standard)

| Description                   | MRT-X 2570  | MRT-X 3060  |
|-------------------------------|---|---|
| Measurement                   | 445/65 R22.5  | 445/65 R22.5  |
| Driving wheels (front / rear) | 2 / 2   | 2 / 2   |
| Driving modes                 | 2-wheel steer, 4-wheel concentric steer, 4-wheel "crab" steer | 2-wheel steer, 4-wheel concentric steer, 4-wheel "crab" steer |

Table 45. Stabilizers

| Description         | MRT-X2570                                      | MRT-X 3060                                     |
|---------------------|--|--|
| Type of stabilizers | Double telescopic                              | Double telescopic                              |
| Controls            | Individual or simultaneous stabilizer controls | Individual or simultaneous stabilizer controls |

Table 46. Engine

| Description                        | Unit              | MRT-X 2570                       | MRT-X 3060                       |
|------------------------------------|-------------------|----------------------------------|----------------------------------|
| Engine brand                       |                   | Yanmar                           | Yanmar                           |
| Engine type (standard)             | Stage / Tier      | Stage 3A                         | Stage 3A                         |
| Engine model                       |                   | 4TN107TT-6SMU1                   | 4TN107TT-6SMU1                   |
| Rated power (ISO / TR 14396)       | HP / kW @ rpm     | 173/127 @ 2200                   | 173/127 @ 2200                   |
| Maximum torque                     | Nm @ rpm          | 805 Nm @ 1500                    | 805 Nm @ 1500                    |
| Number of cylinders - Displacement | - cm <sup>3</sup> | 4 - 4567                         | 4 - 4567                         |
| Engine cooling system              |                   | Water cooled                     | Water cooled                     |
| Battery capacity / batteries       |                   | (24V) 2x12V - 120AH - 850 A (EN) | (24V) 2x12V - 120AH - 850 A (EN) |

Table 47. Transmission

| Description                         | Unit      | MRT-X 2570   | MRT-X 3060   |
|-------------------------------------|-----------|--|--|
| Type of transmission                |           | Hydrostatic  | Hydrostatic  |
| Number of gears (forward / reverse) |           | Speedshift (2/2)   | Speedshift (2/2)   |
| Maximum travel speed (unladen)      | km / h    | 40   | 40   |
| Drawbar pull (laden)                | daN       | -  | -  |
| Parking brake                       |           | Automatic with negative action                                     | Automatic with negative action                                     |
| Service brake                       | Hydraulic | Multi-disc type in oil bath integrated in the front and rear axles | Multi-disc type in oil bath integrated in the front and rear axles |

Table 48. Hydraulic circuit

| Description            | Unit      | MRT-X 2570 |         | MRT-X 3060 |         |
|------------------------|-----------|------------|---------|------------|---------|
| Type of hydraulic pump |           | LS pump    |         | LS pump    |         |
| Hydraulic flow         | l / min   | 185 l / m  |         | 185 l / m  |         |
| Hydraulic pressure     | bar - PSI | 350        | 5076.32 | 350        | 5076.32 |

Table 49. Liquid capacity

| Description                         | Unit       | MRT-X 2570 |      | MRT-X 3060 |      |
|-------------------------------------|------------|------------|------|------------|------|
| Motor oil                           | L - US gal | 13         | 2.85 | 13         | 2.85 |
| Hydraulic oil tank and transmission | L - US gal | 300        | 66   | 300        | 66   |
| Fuel tank                           | L - US gal | 320        | 70.4 | 320        | 70.4 |

Table 50. Noise and vibrations

| <b>Description</b>  | <b>Unit</b>        | <b>MRT-X 2570</b> | <b>MRT-X 3060</b> |
|---|--------------------|-------------------|-------------------|
| <b>Acoustic pressure in the driver's cabin LpA<br/>(according to NF EN 12053)</b>   | dB (A)             | -                 | -                 |
| <b>Guaranteed noise level in the environment LwA<br/>(according to Directive 2000/14 / EC modified by Directive<br/>2005/88 / EC)</b> | dB (A)             | -                 | -                 |
| <b>The weighted average acceleration transmitted to the<br/>boom system/ driver's hand<br/>(according to ISO 5349-2)</b>              | m / s <sup>2</sup> | -                 | -                 |

Table 51. Miscellaneous

| <b>Description</b>                            | <b>MRT-X 2570</b>     | <b>MRT-X 3060</b>     |
|---|-----------------------|-----------------------|
| <b>Driving wheels (front / rear)</b>          | 2 / 2                 | 2 / 2                 |
| <b>Controls</b>                               | 2 Joysticks           | 2 Joysticks           |
| <b>Safety cabin approval</b>                  | ROPS / FOPS (Level 2) | ROPS / FOPS (Level 2) |
| <b>Attachment recognition system (E-Reco)</b> | E-Reco                | E-Reco                |

### 2.2.7 CAPACITY AND LOAD CHARTS

The following pages show the load charts of each machine model with the standard attachment CAF 1030 (fork carrier).

#### MRT 2570 360 175Y ST5 S1 / MRT-X 2570 360 175Y ST3A S1 + CAF 1030/7T F 125x60x1200B

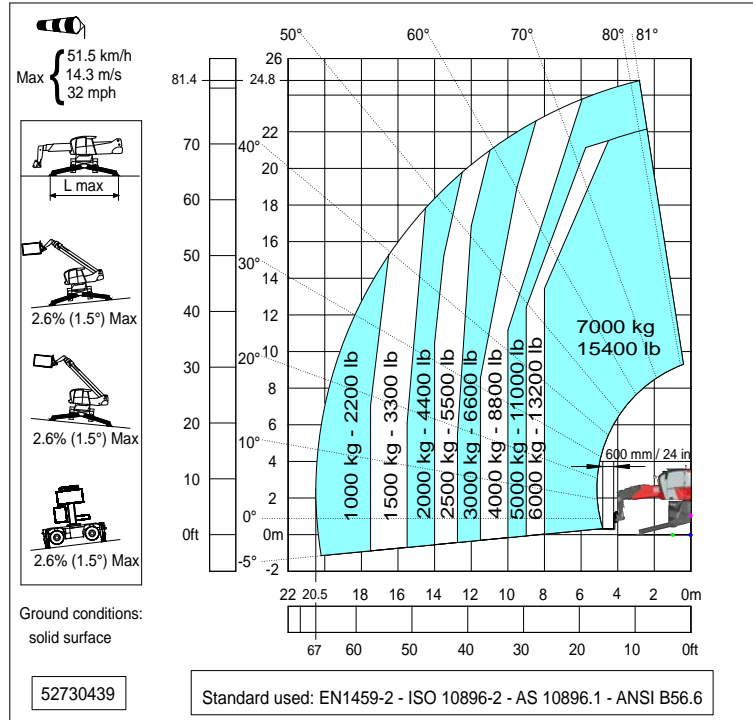

Figure 39:

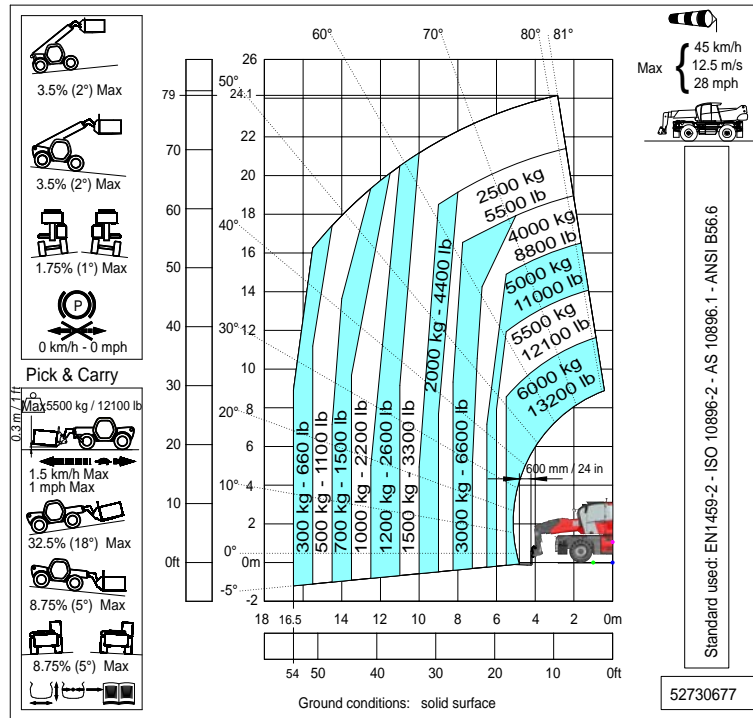

Figure 40:

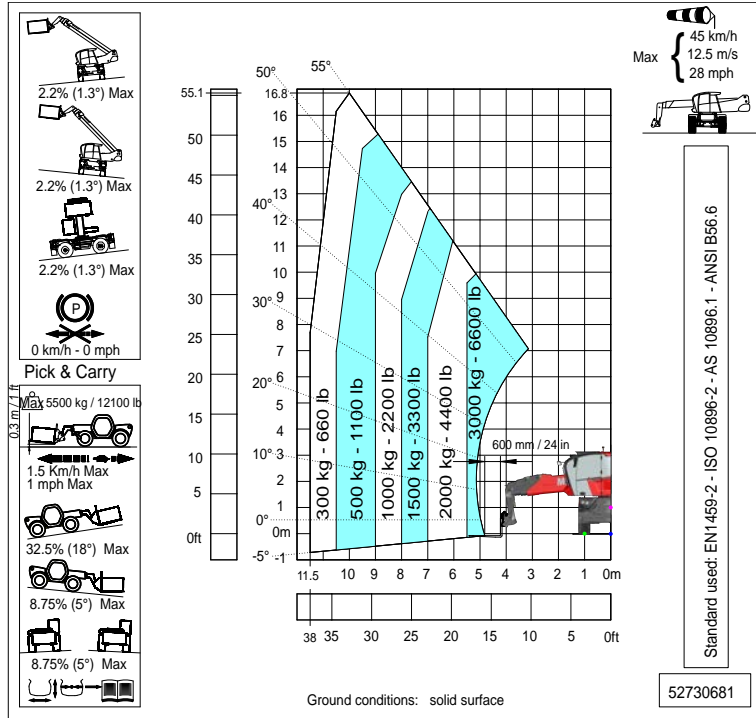

Figure 41:

**MRT 3060 360 175Y ST5 S1 / MRT-X 3060  
360 175Y ST3A S1 + CAF 1030/6T F  
100x60x1200B**

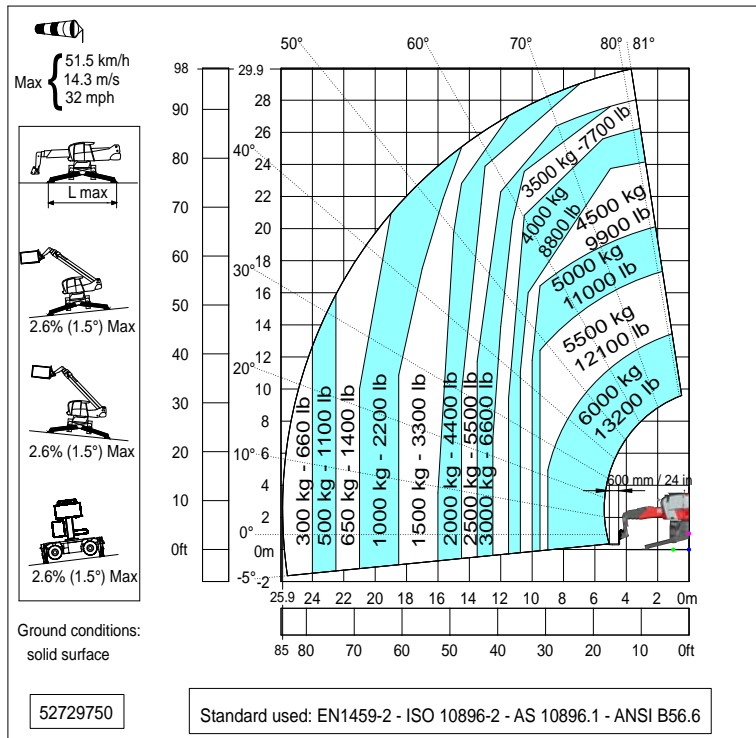

Figure 42:

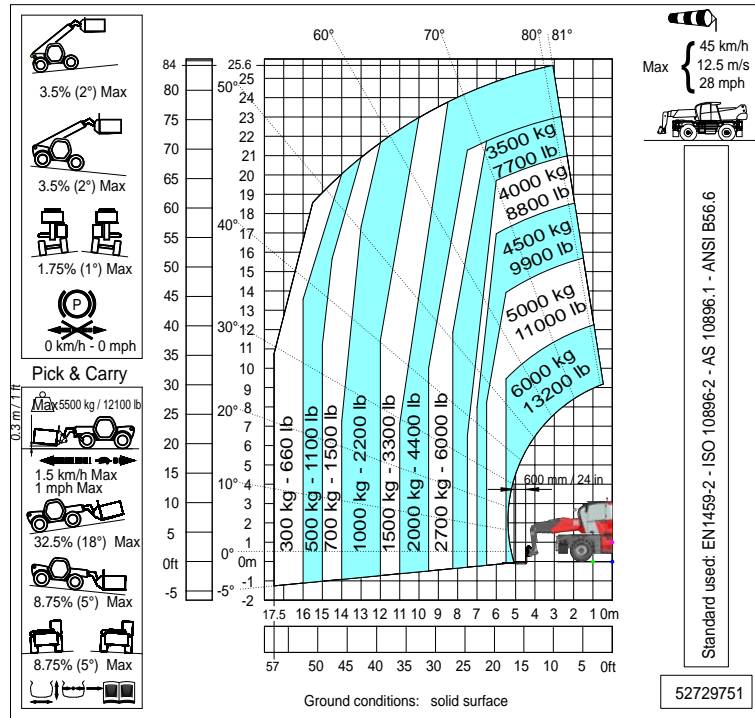

Figure 43:

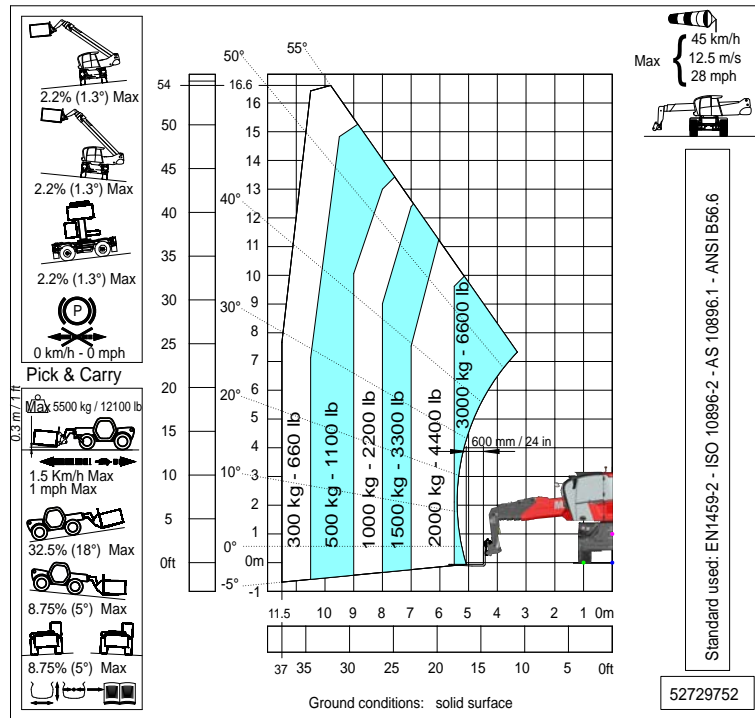

Figure 44:



2.2.8 "CE" DECLARATION OF CONFORMITY

1) **DECLARATION "CE" DE CONFORMITE (originale)**  
**"EC" DECLARATION OF CONFORMITY (original)**

2) La société, *The company* : **MANITOU ITALIA S.r.l.**  
 3) Adresse, *Address* : **Via Cristoforo Colombo 2, 41013 Cavazzona in Castelfranco Emilia - ITALIA**  
 4) Dossier technique, *Technical file* : **MANITOU ITALIA S.r.l. Via Cristoforo Colombo 2, 41013 Cavazzona in Castelfranco Emilia - ITALIA**

5) Constructeur de la machine décrite ci-après, *Manufacturer of the machine described below* :  
**CHARIOT TELESCOPIQUE ROTATIF, Slewing variable-reach truck**  
**MRT 2660 360 160Y ST5 S1**  
**N°>MAN00000K01057441<**

6) Déclare que cette machine, *Declares that this machine* :

7)- Est conforme aux directives suivantes et à leurs transpositions en droit national, *Complies with the following directives and their transpositions into national law* :

**2006/42/CE**

8) - Pour les machines annexe IV, *For annex IV machines* :

9) - Numéro d'attestation, *Certificate number* :

10) - Organisme notifié, *Notified body* :

**2000/14/CE + 2005/88/CE**

11) - Procédure appliquée, *Applied procedure* : **Annexe VI - 2000 / 14 / CE proc.I**

10) - Organisme notifié, *Notified body* : **ECO Certificazioni S.p.A., Via Mengolina, 33 48018 Faenza**

(RA) ITALIA - *Notified Body n. 0714*

12) - Niveau de puissance acoustique, *Sound power level* :

13) Mesuré, *Measured* : **107 dB (A)**

14) Garanti, *Guaranteed* : **108 dB (A)**

**2014/30/UE**

15)-Normes harmonisées utilisées, *Harmonised standards used* : **EN ISO 13766-1:2018 , EN 1459-2:2015+A1:2018**

16)-Normes ou dispositions techniques utilisées, *Standards or technical provisions used* : /

17) - Fait à, *Done at* : **CASTELFRANCO EMILIA**    18) - Date, *Date* : **22/07/2021**

19) - Nom du signataire, *Name of signatory* : **IOTTI MARCO**

20) - Fonction, *Function* : **DIRECTEUR GENERAL**

21) - Signature, *Signature* :

**MANITOU ITALIA Srl**  
 A Socio Unico - Sede Legale e Amm.va - Via C. Colombo, 2  
 Località Cavazzona, 41013 CASTELFRANCO E. (MO)  
 Tel. 059 959811 - Fax 059 / 959850  
 Cap. Sociale 2.000.000 I.V.  
 Reg. Imp. Di Modena e C.F. 0173970369  
 P.IVA IT 02591050360 - N. Mecc. MO 033322 R.E.A. 148776

Figure 48: First page of declaration of conformity

**bg :** 1) удостоверение за «CE» съответствие (оригинална), 2) Фирмата, 3) Адрес, 4) Техническо досие, 5) Фабрикант на описаната по-долу машина, 6) Обявява, че тази машина, 7) Отговаря на следните директиви и на тяхното съответствие национално право, 8) За машините към допълнение IV, 9) Номер на удостоверението, 10) Наименувана фирма, 15) хармонизирани стандарти използвани, 16) стандарти или технически правила, използвани, 17) Изработено в, 18) Дата, 19) Име на разписалия се, 20) Функция, 21) Функция.

**cs :** 1) ES prohlášení o shodě (původní), 2) Název společnosti, 3) Adresa, 4) Technická dokumentace, 5) Výrobce níže uvedeného stroje, 6) Prohlašuje, že tento stroj, 7) Je v souladu s následujícími směrnicemi a směrnicemi transponovanými do vnitrostátního práva, 8) Pro stroje v příloze IV, 9) Číslo certifikátu, 10) Notifikační orgán, 15) harmonizované normy použity, 16) Norem a technických pravidel používaných, 17) Místo vydání, 18) Datum vydání, 19) Jméno podepsaného, 20) Funkce, 21) Podpis.

**da :** 1) EF Overensstemmelseserklæring (original), 2) Firmaet, 3) Adresse, 4) tekniske dossier, 5) Konstruktor af nedenfor beskrevne maskine, 6) Erklærer, at denne maskine, 7) Overholder nedennævnte direktiver og disses gennemførelse til national ret, 8) For maskiner under bilag IV, 9) Certifikat nummer, 10) Bemyndigede organ, 15) harmoniserede standarder, der anvendes, 16) standarder eller tekniske regler, 17) Udfærdiget i, 18) Dato, 19) Underskrivers navn, 20) Funktion, 21) Underskrift.

**de :** 1) EG-Konformitätserklärung (original), 2) Die Firma, 3) Adresse, 4) Technischen Unterlagen, 5) Hersteller der nachfolgend beschriebenen Maschine, 6) Erklärt, dass diese Maschine, 7) den folgenden Richtlinien und deren Umsetzung in die nationale Gesetzgebung entspricht, 8) Für die Maschinen laut Anhang IV, 9) Bescheinigungsnummer, 10) Benannte Stelle, 15) angewandten harmonisierten Normen, 16) angewandten sonstigen technischen Normen und Spezifikationen, 17) Ausgestellt in, 18) Datum, 19) Name des Unterzeichners, 20) Funktion, 21) Unterschrift.

**el :** 1) Δήλωση συμμόρφωσης CE (πρωτότυπο), 2) Η εταιρεία, 3) Διεύθυνση, 4) τεχνικό φάκελο, 5) Κατασκευάστρια του εξής περιγραφόμενου μηχανήματος, 6) Δηλώνει ότι αυτό το μηχάνημα, 7) Είναι σύμφωνο με τις εξής οδηγίες και τις προσαρμογές τους στο εθνικό δίκαιο, 8) Για τα μηχανήματα παραρτήματος IV, 9) Αριθμός δήλωσης, 10) Κοινοποιημένος φορέας, 15) εναρμονισμένα πρότυπα που χρησιμοποιούνται, 16) Πρότυπα ή τεχνικούς κανόνες που χρησιμοποιούνται, 16) Είναι σύμφωνο με τα εξής πρότυπα και τεχνικές διατάξεις, 17) Έν, 18) Ημερομηνία, 19) Ονομα του υπογράφοντος, 20) Θέση, 21) Υπογραφή.

**es :** 1) Declaración DE de conformidad (original), 2) La sociedad, 3) Dirección, 4) expediente técnico, 5) Constructor de la máquina descrita a continuación, 6) Declara que esta máquina, 7) Está conforme a las siguientes directivas y a sus transposiciones en derecho nacional, 8) Para las máquinas anexo IV, 9) Número de certificación, 10) Organismo notificado, 15) normas armonizadas utilizadas, 16) Otras normas o especificaciones técnicas utilizadas, 17) Hecho en, 18) Fecha, 19) Nombre del signatario, 20) Función, 21) Firma.

**et :** 1) EÜ vastavusdeklaratsioon (algupärane), 2) Äriühing, 3) Aadress, 4) Tehniline dokumentatsioon, 5) Seadme tootja, 6) Kinnitab, et see toode, 7) On vastavuses järgmistele direktiividele ja nende riigisisesele õigussesse ülevõtmiseks vastavõetud õigusaktidega, 8) IV lisas loetletud seadmete puhul, 9) Tunnistuse number, 10) Sertifitseerimisasutus, 15) kasutatud ühtlustatud standardite, 16) Muud standardites või spetsifikatsioonides kasutatakse, 17) Valjaandmise koht, 18) Valjaandmise aeg, 19) Allkirjastaja nimi, 20) Amet, 21) Allkiri.

**fi :** 1) EY-vaatimustenmukaisuusvakuutus (alkuperäiset), 2) Yritys, 3) Osoite, 4) teknisen eritelmän, 5) Jäljessä kuvattujen CE-merkintäalustajien valmistaja, 6) Vakuuttaa, että tämä kone, 7) Täyttää seuraavien direktiivien sekä niitä vastaavien kansallisten säännösten vaatimukset, 8) Liitteen IV mukaisesti, 9) Todistuksen numero, 10) Ilmoitettu laitos, 15) yhdenmukaistettuja standardeja käytetään, 16) muita standardeja tai, 17) Paikka, 18) Aika, 19) Allekirjoittajan nimi, 20) Ammatti, 21) Allekirjoitus.

**ga :** 1) «CE» dearbhú comhréireachta (bunaidh), 2) An comhlacht, 3) Seoladh, 4) comhad teicniúil, 5) An tóir, 6) Ainm an t-úchraí, 7) Go gcloíonn sé le na teoracha seo a leanas agus a trasúimh isteach i ndlí náisiúnta, 8) Le haghaidh na n-ábhaicéad, 9) An t-úchraí, 10) Comhlacht a chuireadh in bhfios, 15) caighdeán comhchuibhithe a úsáidtear, 16) caighdeán eile nó sonraíochtaí teicniúla a úsáidtear, 17) Dáta, 18) Ainm, 19) Ainm an tsintheora, 20) Feidhm, 21) Síniú.

**hu :** 1) CE megfeleléségi nyilatkozat (eredeti), 2) A vállalat, 3) Cím, 4) műszaki dokumentáció, 5) A gépjármű gyártója, 6) Kijelenti, hogy a gép, 7) Megfelel az alábbi irányelveknek valamint azok honosított előírásainak, 8) A IV. mellékletben felsorolt, 9) azonosított szervezet, 10) Ertesített szervezet, 15) felhasznált harmonizált szabványok, 16) egyéb felhasznált műszaki szabványok és előírások hivatkozásai, 17) Helyszín, 18) Dátum, 19) Aláírás, 20) Funkció, 21) Aláírás.

**is :** 1) Samræmisvottorð ESB (upprunalega), 2) Fyrirtækið, 3) Aðsetningu og tegundarkrá, 4) Sniður tækisins sem lýst er hér á eftir, 6) Staðfestir að tækioð, 7) Samræmist eftirfarandi stöðlum og staðfærslu þeirra með hljóðum, 8) Fyrirfarandi, 9) Staðfestingarnúmer, 10) Tilkynt til, 15) samhæfða staðla sem notaðir, 16) önnur staðlar eða forskrifir notað, 17) Staður, 18) Dátum, 19) Nafn undirritaðs, 20) Staða, 21) Undirskrift.

**it :** 1) Dichiarazione CE di conformità (originale), 2) Società, 3) Indirizzo, 4) fascicolo tecnico, 5) Costruttore della macchina descritta di seguito, 6) Dichiaro che questa macchina, 7) È conforme alle direttive seguenti e alle relative disposizioni in diritto nazionale, 8) Per le macchine Allegato IV, 9) Numero di Attestazione, 10) Organismo notificato, 15) norme armonizzate applicate, 16) altre norme e specifiche tecniche applicate, 17) Luogo, 18) Data, 19) Nome del firmatario, 20) Funzione, 21) Firma.

**lt :** 1) CE atitikties deklaracija (originalas), 2) Uždavinys, 3) Adresas, 4) Techninė byla, 5) Žemiau nurodytas įrenginio gamintojas, 6) Pareiškia, kad šis įrenginys, 7) Atitinka toliau nurodytas direktyvas ir į nacionalinius teisės aktus, 8) IV priedas del mašinų, 9) Sertifikato Nr., 10) Paskelbtąjį įstaigą, 15) suderintus standartus naudojamus, 16) Kiti standartai ir techninės specifikacijos, 17) Vietovė, 18) Data, 19) Pasirašiusio asmens vardas ir pavardė, 20) Pareigos, 21) Parašas.

**lv :** 1) EK atbilstības deklarācija (oriģināls), 2) Uzņēmums, 3) Adrese, 4) tehniskās lietas, 5) Tālāk aprakstīts iekārtas ražotājs, 6) Apliecinā, ka šī iekārta, 7) Ir atbilstoša tālāk norādītajām direktīvām un to transpozīcijai nacionālajā likumdošanā, 8) Iekārtām IV pielikumā, 9) Apliecināšanas numurs, 10) Reģistrētā organizācija, 15) lietotajiem saskaņotajiem standartiem, 16) lietotajiem tehniskajiem standartiem un specifikācijām, 17) Sastādīts, 18) Datums, 19) Parakstītāja vārds, 20) Amats, 21) Paraksts.

**mt :** 1) Dikjarazzjoni ta' Konformità KE (originali), 2) Il-kumpanija, 3) Indirizz, 4) fajl tekniku, 5) Manifattriċi tal-magna deskritta hawn isfel, 6) Tiddikjara li din il-magna, 7) Hija konformi hija konformi mad-Direttivi segwenti u l-ligijiet li jimplimentawhom fl-ilgi nazzjonali, 8) Ghall-magni fl-Anness IV, 9) Numru taċ-certifikat, 10) Entità notifikata, 15) l-istandards armonizzati użati, 16) standards tekniċi u specifikazzjonijiet oħra użati, 17) Magħmulf, 18) Data, 19) l-sem il-firmatarju, 20) Kariga, 21) Firma.

**nl :** 1) EG-verklaring van overeenstemming (oorspronkelijke), 2) Het bedrijf, 3) Adres, 4) technisch dossier, 5) Constructeur van de hierna genoemde machine, 6) Verklaart dat deze machine, 7) In overeenstemming is met de volgende richtlijnen en hun omzettingen in het nationale recht, 8) Voor machines van bijlage IV, 9) Goedkeuringsnummer, 10) Aangezegde instelling, 15) gehanteerde geharmoniseerde normen, 16) andere gehanteerde technische normen en specificaties, 17) Opgemaakt te, 18) Datum, 19) Naam van ondergetekende, 20) Functie, 21) Handtekening.

**no :** 1) CE-samsvarserklæring (original), 2) Selskapet, 3) Adresse, 4) tekniske arkiv, 5) Fabrikant av følgende maskin, 6) Erklærer at denne maskinen, 7) Oppfyller kravene i følgende direktiver, med nasjonale gjennomføringsbestemmelser, 8) For maskinene i tillegg IV, 9) Attestnummer, 10) Notifisert organ, 15) harmoniserte standarder som brukes, 16) Andre standarder og spesifikasjoner brukt, 17) Utstedt i, 18) Dato, 19) Underskriverens navn, 20) Stilling, 21) Underskrift.

**pl :** 1) Deklaracja zgodności CE (oryginalne), 2) Spółka, 3) Adres, 4) dokumentacji technicznej, 5) Wykonawca maszyny opisanej poniżej, 6) Oświadczam, że ta maszyna, 7) Jest zgodna z następującymi dyrektywami i odpowiadającymi przepisami prawa krajowego, 8) Dla maszyn załącznik IV, 9) Numer certyfikatu, 10) Jednostka certyfikująca, 15) zastosowanych norm zharmonizowanych, 16) innych zastosowanych norm technicznych i specyfikacji, 17) Sporządzono w, 18) Data, 19) Nazwisko podpisującego, 20) Stanowisko, 21) Podpis.

**pt :** 1) Declaração de conformidade CE (original), 2) A empresa, 3) Morada, 4) processo técnico, 5) Fabricante da máquina descrita abaixo, 6) Declara que esta máquina, 7) Está em conformidade às directivas seguintes e às suas transposições para o direito nacional, 8) Para as máquinas no anexo IV, 9) Número de certificado, 10) Entidade notificada, 15) normas harmonizadas utilizadas, 16) outras normas e especificações técnicas utilizadas, 17) Elaborado em, 18) Data, 19) Nome do signatário, 20) Cargo, 21) Assinatura.

**ro :** 1) Declarație de conformitate CE (originală), 2) Societatea, 3) Adresa, 4) cartii tehnic, 5) Constructor al mașinii descrise mai jos, 6) Declară că prezenta mașină, 7) Este conformă cu directivele următoare și cu transpunerea lor în dreptul național, 8) Pentru mașinile din anexa IV, 9) Număr de atestare, 10) Organism notificat, 15) standardele armonizate utilizate, 16) alte standarde și specificații tehnice utilizate, 17) Întocmit la, 18) Data, 19) Numele persoanei care semnează, 20) Funcția, 21) Semnătura.

**sk :** 1) ES vyhlásenie o zhode (pôvodný), 2) Názov spoločnosti, 3) Adresa, 4) technickej dokumentácie, 5) Výrobca nižšie opísaného stroja, 6) Vyhlasuje, že tento stroj, 7) Je v súlade s nasledujúcimi smernicami a smernicami transponovanými do vnútroštátneho práva, 8) Pre stroje v prílohe IV, 9) Číslo certifikačného orgánu, 15) použité harmonizované normy, 16) použité iné technické normy a predpisy, 17) Miesto vydania, 18) Dátum vydania, 19) Meno podpisujúceho, 20) Funkcia, 21) Podpis.

**sl :** 1) ES Izjava o ustreznosti (izvirna), 2) Družba, 3) Naslov, 4) tehnične dokumentacije, 5) Proizvajalac tukaj opisanega stroja, 6) Izjavlja, da je ta stroj, 7) Ustreza naslednjim direktivam in njihovi transpoziciji v državno pravo, 8) Za stroje priloga IV, 9) Številka potrdila, 10) Obvestilo organu, 15) uporabljene harmonizirane standarde, 16) druge uporabljene tehnične standarde in zahteve, 17) V, 18) Datum, 19) Ime podpisnika, 20) Funkcija, 21) Podpis.

**sv :** 1) CE-försäkran om överensstämmelse (original), 2) Företaget, 3) Adress, 4) tekniska dokumentationen, 5) Konstruktor av nedan beskrivna maskin, 6) Försäkrar att denna maskin, 7) Överensstämmer med nedanstående direktiv och införlivande av dem i nationell rätt, 8) För maskinerna i bilaga IV, 9) Nummer för godkännande, 10) Organism som underrättats, 15) Harmoniserade standarder som använts, 16) andra tekniska standarder och specifikationer som använts, 17) Upprättat i, 18) Datum, 19) Namn på den som undertecknat, 20) Befattning, 21) Namnteckning.

Figure 49: Second page of the declaration of conformity

## 2.3. ENVIRONMENT

### 2.3.1 EXHAUST GAS AFTER-TREATMENT SYSTEM (DPF + SCR + EGR) AND POLLUTANT GAS EMISSIONS CONTROL

(Excluding MRT-X model machines)

#### Main components of the after-treatment system

- Diesel Particulate Filter (DPF).
- Catalytic converter (SCR).
- Valve (EGR).
- DEF tank.

#### Operation of the exhaust gas after-treatment system

This system controls and reduces the harmful emissions of the exhaust gas produced by the engine.

In order to comply with the regulations set by the European Union (EU) and by the Environmental Protection Agency (EPA / ARB), a polluting gas emission control system has been designed that is activated when there are emissions-related warnings.

The following events trigger a warning light:

- Low DEF level.
- Faulty after-treatment system (SCR + EGR + DPF).

If a fault occurs in the after-treatment system or if the fault is not resolved, the system intervenes by automatically and gradually reducing engine performance.

The system is equipped with an emergency command ("override" feature) in order to temporarily disable power reductions caused by the emission control system. The feature is available for a limited time (30 min.) and is designed to allow the operator to move the telehandler to a safe location.

The SCR system is monitored to verify the possible formation and accumulation of DEF crystals (crystallization) inside it or in the circuit. As soon as crystallization is detected, a parked regeneration request (telehandler stopped) is sent, indicated by a flashing regeneration light.







After the warning, parked regeneration must be started by the operator as soon as possible.

If the parked regeneration (telehandler stopped) is not carried out, the polluting gas emission control system activates the specific engine protection features.

The number of regenerations is therefore monitored.

On the display in the cabin, the display and monitoring of the after-treatment system is carried out by means of light indicators.

Table 72. Overview of the indicator lights

|   |   |
|---|---|
|    | <p>Engine power reduction strategies and control for low level DEF tank.<br/>Indicator behavior:</p> <ul style="list-style-type: none"> <li>• Steady bright = attention step (Level &lt;10%).</li> <li>• Flashing 1Hz = Phase 1* (Level 0%). Strategy: engine weakening</li> <li>• Flashing 1Hz = Phase 2* (Level 0% and DEF pump pressure 0%). Strategy: engine weakening and limited speed.</li> </ul>  |
|    | <p>Emission-related malfunction of the exhaust gas after-treatment system (SCR / EGR / DPF) or DEF supply.</p> <ul style="list-style-type: none"> <li>• Steady bright = filter replacement required.</li> <li>• Flashing 1hz = filter replacement required.</li> <li>• Flashing 1hz = filter replacement required Phase 1*. Strategy: engine weakening.</li> <li>• Flashing 1hz = filter replacement required, system reaction active.</li> </ul> |
|    | Steady bright: DPF filter regeneration required.  |
|    | Steady bright: DPF regeneration approved and activated.   |
|   | Steady bright: DPF regeneration disabled by the operator.   |
|  | Steady bright: regeneration enabled and high temperature of the exhaust gas.  |



\*: **Contact your agent or dealer immediately.**

### Parked regeneration of DPF filter (telehandler stopped)



**DPF regeneration is an automated procedure, which is initiated by the operator when the following warning lights are flashing: o + after 50 hours of operation with an engine speed reduction of 25%.**

Park the telehandler in a safe and sufficiently ventilated place.

Check the following points:

- Neutral gear selector.
- Parking brake applied.
- No action on the manipulator of the hydraulic controls.
- Boom in transport position.
- Accelerator pedal released.
- Manual accelerator not used.

Check that the fuel level is sufficient.

Start the telehandler and run the heat engine for a few minutes to bring it to operating temperature (60° C - 140° F).

Press the button for more than two seconds to start the DPF regeneration procedure.

The steady lighting of the button (blue or yellow) validates the activation of the procedure.

Follow the steps indicated on the information display.



The DPF regeneration procedure should only be interrupted if necessary.

The procedure stops automatically if the operator:

- Operates the joysticks of the hydraulic movements.
- Operates the forward or reverse direction selector.
- Turns off the heat engine.
- Presses the button.

### Alert strategies and engine reduction levels (EU - EPA / ARB)

Different control steps of the exhaust gas after-treatment system and polluting emissions can be identified, which follow one another:

- Normal phase.
- Attention phase.

Once the attention threshold has been exceeded, the polluting gas emissions control system intervenes, in

two stages, reducing engine performance and up to shutdown:

1. Reduction phase 1 = Low level alert.
2. Reduction phase 2 = Severe - final alert.

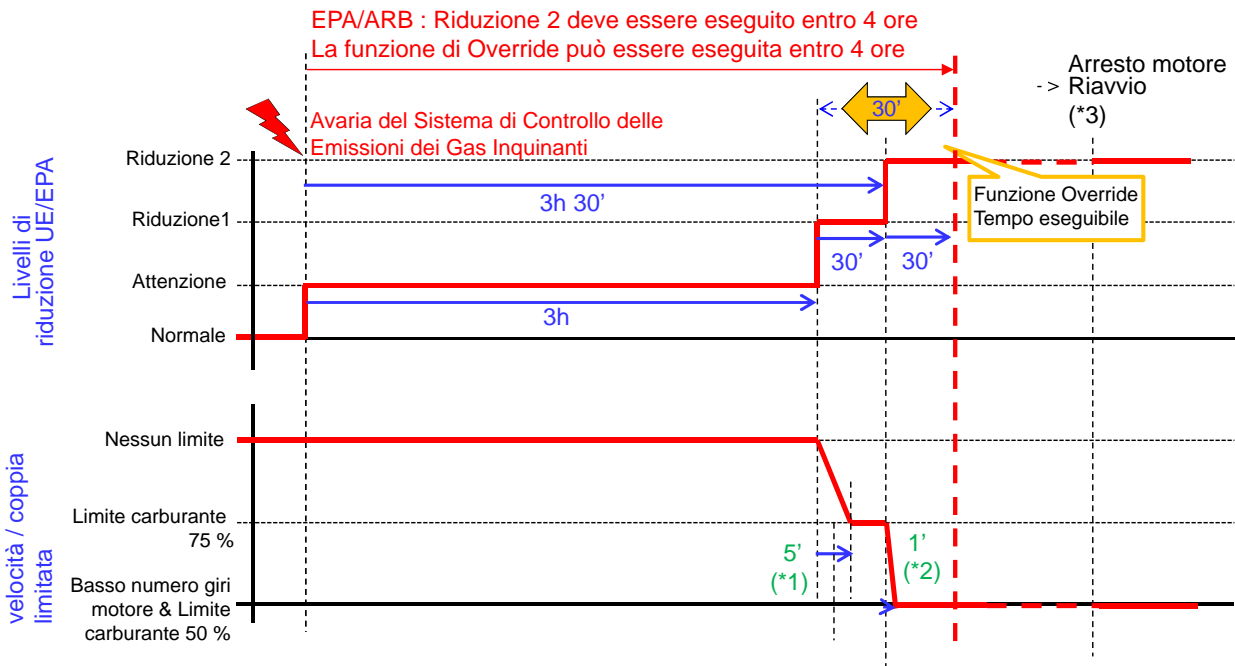

- \*1. Quando la strategia di Riduzione 1 deve esser eseguita, la coppia del motore diminuisce gradualmente e
- \*2. Quando la strategia di Riduzione 2 deve esser eseguita, la coppia del motore diminuisce gradualmente e
- \*3. Dopo il riavvio del motore, il livello di riduzione viene riportato dal livello precedente.

Figure 50: SCR control system chart and EU / EPA strategies

## 2.4. COMPONENTS

### 2.4.1 CONTROLS

#### Driver's cab



Figure 51: Driver's cab

#### Overview

1. Operator's seat.
2. Seat left armrest.

3. Left armrest button console.
4. Left joystick.

5. Service brake pedal and inching control.
6. Adjustable steering column lever.
7. Safety buttons and switches.
8. Control lever for lights, horn, indicator lights and wipers.
9. Steering wheel.
10. Ignition lock.
11. "HMI" display (man-machine interface).
12. Forward / neutral / reverse direction selector.
13. Accelerator pedal.
14. "Emergency stop" button.
15. Right joystick.
16. "HMI" information screen navigator (man-machine interface).
17. Right armrest button console.
18. Seat right armrest.

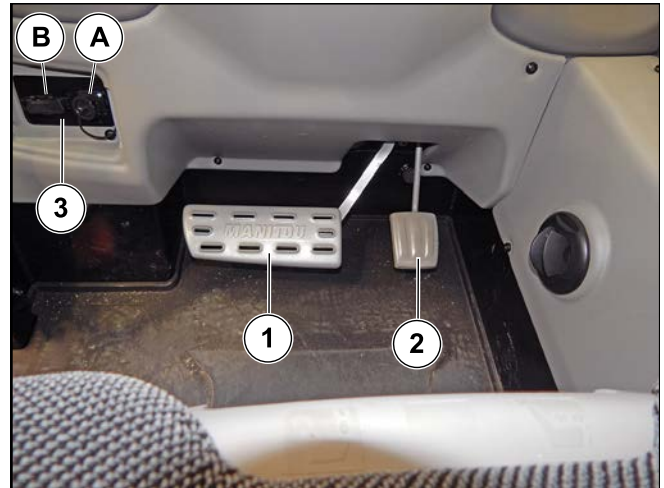

Figure 52: Pedals and diagnosis sockets

## 2.4.2 PEDALS AND DIAGNOSIS SOCKETS

### SERVICE BRAKE PEDAL

The pedal (1) acts on the front and rear wheels and allows you to slow down and block the telescopic handler.

The brake pedal (1) in the first 20 mm of travel works as an Inching pedal allowing for precise and slow movements, in the remaining stroke it produces the braking effect.

### ACCELERATOR PEDAL

Pedal (2) that allows you to vary the speed of the telescopic handler by acting on the number of revolutions made by the heat engine.

### DIAGNOSIS SOCKETS

Remove the cover (3) to access the diagnostics sockets (A) and (B):

1. Machine electronics
2. Machine and engine electronics

## 2.4.3 ADJUSTABLE STEERING COLUMN LEVER

### Adjusting the steering wheel

The lever (1) allows you to adjust the steering wheel to suit the operator.

Push down the lever (1) to loosen the grip of the steering wheel lock:

- Adjust the height.
- Adjust the telescopic adjustment.

Pull the lever (1) up to lock the steering wheel.



Figure 53: Adjusting the steering wheel

### 2.4.4 CONTROL LEVER FOR LIGHTS, HORN, INDICATOR LIGHTS AND WIPERS

The switch controls:

- Turning on the lights.
- Indicators.
- The acoustic signal.
- Wipers.

To control the features move or press (horn) the lever or rotate the 3 selectors.

When some features are enabled, warning lights on the display light up.

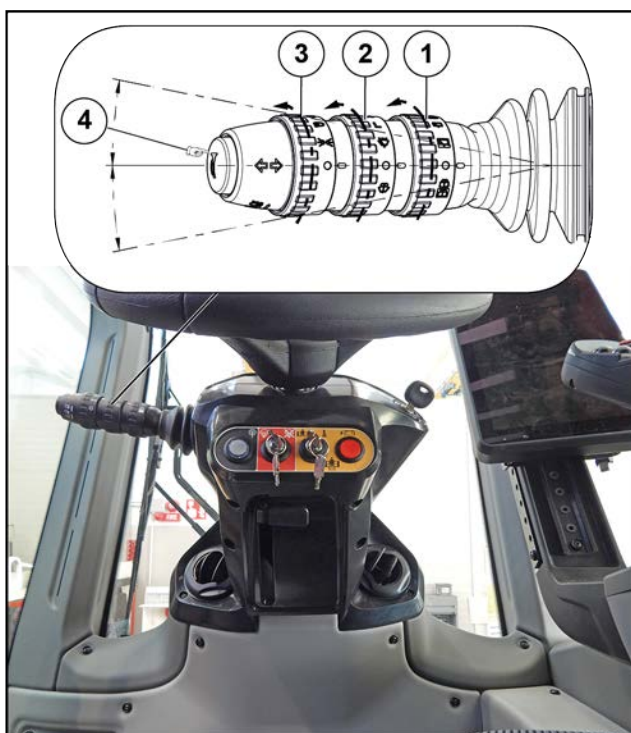

Figure 54: Control lever for lights, horn, indicator lights and wipers

#### Symbols overview

Table 73.

| 1 - REAR AND UPPER WIPER CONTROL RING SELECTOR |  |
|--|--|
|  | Top and rear control (side if present) |
|  | Rear control                           |
|  | Top control                            |

| 1 - REAR AND UPPER WIPER CONTROL RING SELECTOR |  |
|--|--|
|  | Off control  |
|  | Upper and rear window washer control (side if present) |

Table 74. Front wiper control dial selector



| 2 - FRONT WIPER CONTROL RING SELECTOR |                       |
|---------------------------------------|-----------------------|
|                                       | Second speed          |
|                                       | First speed           |
|                                       | Intermittent speed    |
|                                       | Off control           |
|                                       | Window washer control |

Table 75. Front wiper control dial selector

| 3 - LIGHTS CONTROL RING SELECTOR |               |
|----------------------------------|---------------|
|                                  | Rear fog lamp |
|                                  | Dipped beam   |
|                                  | Sidelights    |
|                                  | Off control   |

Table 76. Front wiper control dial selector

| 4 - LEVER CONTROLS |  |
|--------------------|--|
|                    | Horn (press)   |
|                    | Indicator lights <ul style="list-style-type: none"> <li>• Lever up: Turn right</li> <li>• Lever down: Turn left</li> </ul> |

| 4 - LEVER CONTROLS  |                                    |
|---|------------------------------------|
|  | High beams on<br>• Lever forward   |
|  | High beam flashing<br>• Lever back |

### 2.4.5 SIDE REAR VIEW MIRRORS AND USB PORT

#### EXTERNAL SIDE REAR VIEW MIRRORS CONTROLS

Move the control (1) to adjust the visibility from the left (1A) (cabin side) or right (1B) (engine side) rear view mirror.

Turn the knob (1) clockwise (A) to select the left rear view mirror (1A).

Turn the knob (1) counterclockwise (B) to select the right rear view mirror (1B).

#### USB PORT

The USB port (2) allows the power supply of compatible electronic devices and communication with the vehicle stereo.

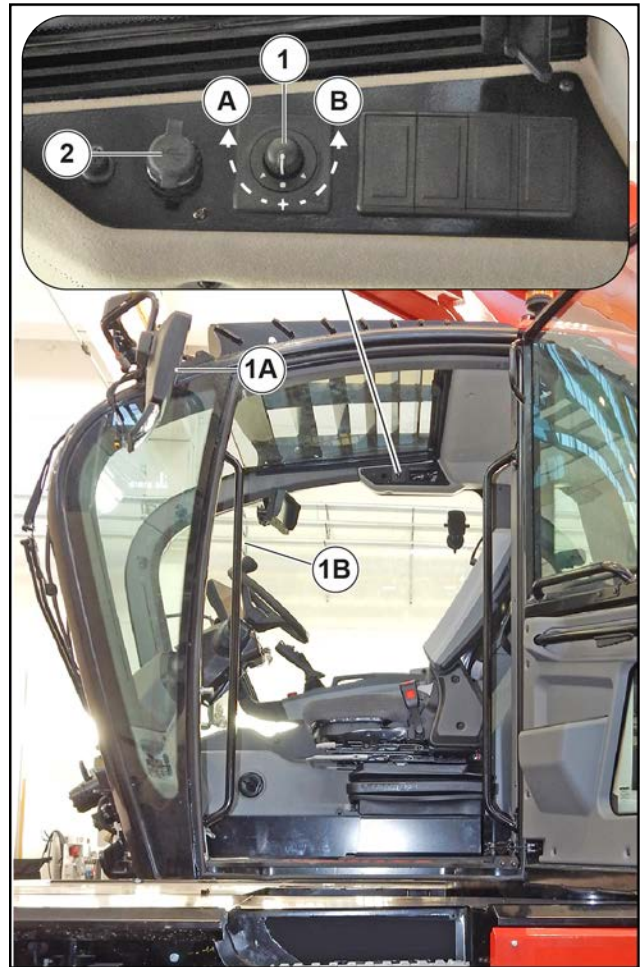

Figure 55: External side rear view mirrors control and USB port

### 2.4.6 SUNSHADE

The sunshade (1) can completely obscure the top of the cabin window (2) and drop onto a part of the front window (3).

Move the sunshade (1) at the top of the window (2) forwards or backwards and release it in the desired position.

Move the sunshade (1) as far as possible from the top of the window (2) until it slides to obscure the front windshield (3) and fasten it to the fasteners (4) positioned on cabin uprights.

**⚠ DANGER**

#### Risk of injury to the operator

When returning to its position, the sunshade could suddenly snap backwards with the risk of breaking or hitting the operator.

When unhooking the sunshade (1) from the front window (3), do not release it, but hold onto it until it is completely retracted.

### 2.4.7 DISPLAY HEIGHT ADJUSTMENT KNOB

To move the Display to the desired height, pull and hold the knob (1) located on the side of the Display (2).

To lock the position of the Display, release the knob (1).



Figure 56: Display height adjustment knob

### 2.4.8 CABIN ACCESSORIES

The following standard accessories are available in the cabin of all machine models:

- 12V SOCKET (1)
- BEVERAGE HOLDER (2)
- MOBILE PHONE HOLDER (3)



Figure 57: Cabin accessories

### 2.4.9 CEILING LIGHT AND REAR WINDOW OPENING LEVER

#### CEILING LAMP

The switch (1) is incorporated in the ceiling light (2).

The switch (1) has two positions:

- Continuous lighting.
- Shutdown.

#### REAR WINDOW OPENING LEVER

To open the rear window (3), turn the lever (4) clockwise and push the window (3).

#### Emergency exit

If it is impossible to get out of the cabin door or the front windshield opening, use the rear window (3) as an emergency exit.

Remove the split pin (4A) to fully open the rear window (3).



Figure 58: Ceiling light and rear window opening lever

### 2.4.10 OPENING THE DOOR AND DOOR WINDOW

#### DOOR WINDOW RELEASE LEVER

To open the door window, grasp the bar (2) and push the lever (1) back.

#### DOOR OPENING HANDLE

To open the door, grasp the bar (3) and press the handle (3A).



Figure 59: Opening the door and door window

### 2.4.11 DOOR WINDOW RELEASE LEVER FROM INSIDE CABIN

To unlock the door window, operate the lever (1).

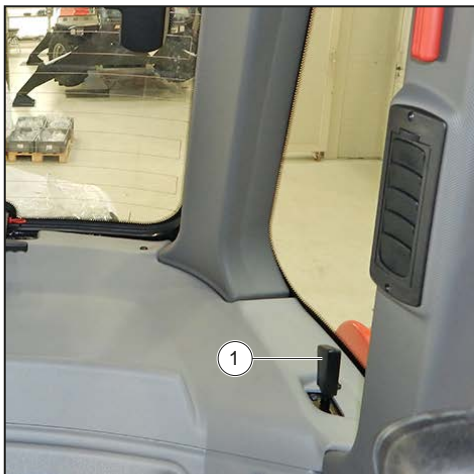

Figure 60: Door window release lever from inside cabin

### 2.4.12 DOOR WINDOW RELEASE LEVER FROM OUTSIDE CABIN

The lever (1) is located under the cabin. To unlock the door window, grasp the lever (1) and push it back.



Figure 61: Door window release lever from outside cabin

## 2.4.13 AIR DIFFUSERS

### AIR DIFFUSERS FOR DEMISTING SIDE AND FRONT WINDOWS

For optimum efficiency, before turning on the air diffusers (1) for demisting the windows, close the heating air vents (2).

### HEATING AIR VENTS

The heating vents (2) allow for distributing ventilated air inside the cabin, on the upper (2A), rear (2B) and lower (2C) parts.



Figure 62: Demisting diffusers and heating air vents

### 2.4.14 REGISTRATION PLATE

The vehicle is designed for the posting of the registration plate (1) for road traffic and its lighting (2).

The registration plate must comply with mandatory regulations in the country where the vehicle is registered.

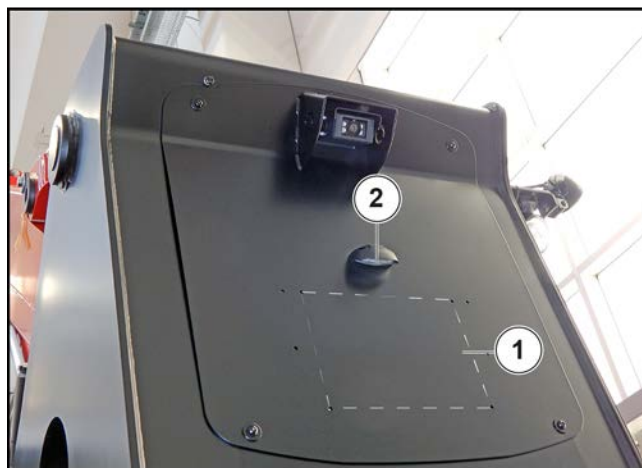

Figure 63: License plate and plate lighting

### 2.4.15 HEADLIGHTS

1. Front left turn signal light (amber).
2. Front left low beam light (white).
3. Front left high beam light (white).
4. Front left parking light (white) with daylight feature.
5. Front right turn signal light (white).
6. Front right low beam light (white).
7. Front right high beam light (white).
8. Front right parking light (white) with daylight feature.

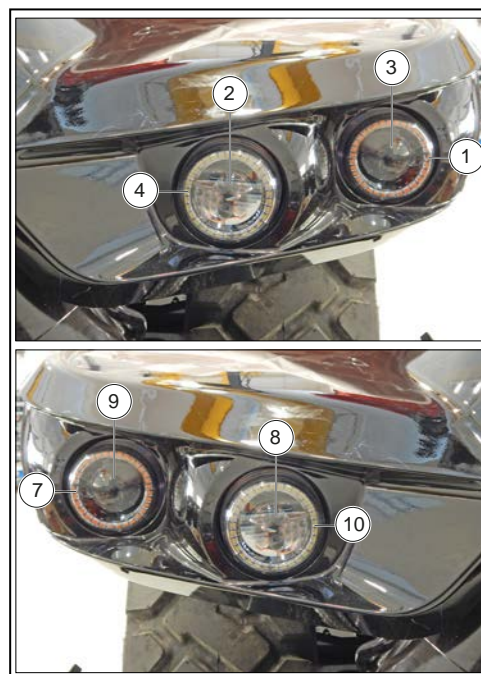

Figure 64: Headlights

### 2.4.16 BEACON AND SIGNAL HEADLIGHTS

#### AMBER LED BEACON

The beacon (1) must be turned on every time the vehicle is used to indicate that it is in operation.

The beacon (1) is turned on from the cabin by pressing the button on the "HMI" navigator.

#### RED LED HEADLIGHT



#### Risk of vehicle overturning

When disabling the vehicle's Manitou Safety System (MSS) there is a risk of the vehicle turning over.

The headlight (2) turns on steadily together with an acoustic signal to indicate that the vehicle's Manitou Safety System (MSS) has been temporarily disabled by the operator, and flashes if the machine reaches 100% load status.

#### FLASHING WHITE LED HEADLIGHT

The headlight (3) on (slow double white flash) warns and indicates that the remote control feature is enabled and that the telescopic handler is being remotely controlled.

The headlight (3) off, indicates that the remote control feature is not active.

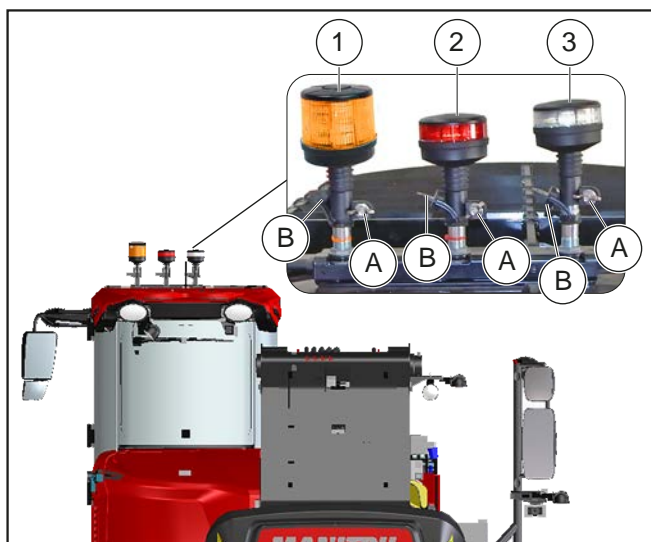

Figure 65: Headlights and beacon

The beacon (1) and the headlights (2) and (3) can be tilted to reduce, when necessary, the overall space taken up by the telescopic handler.

The beacon (1) and the headlights (2) and (3) can also be disassembled to prevent theft:

- Unscrew the nut (A) and remove the beacon or the headlights.
- Protect the base with the cover (B).

### 2.4.17 BATTERY DISCONNECT SWITCH

It allows for quickly isolating the battery, for example in case of intervention on the electric circuit or in case of welding.

1. Switch off the telehandler.
2. Wait at least 30 seconds.
3. Operate the switch (1).
4. Wait for the warning light (1a) to go out, from 30 seconds to 5 min., before disconnecting the battery (1).



*Wait for the warning light (1a) to go out before disconnecting the battery (1). This waiting time is required for the diesel emission fluid (DEF) system.*



Figure 66: Battery disconnect switch

### 2.4.18 BOOM SAFETY WEDGE



*Only use the safety wedge (1) supplied with the telehandler.*

**⚠ DANGER****Risk of crushing**

The safety wedge must be installed by accessing the walkable surface of the undercarriage from the right side staircase.

During installation of the safety wedge, do not stand under the telescopic boom.

The telescopic handler is equipped with a safety wedge (1) which prevents accidental descent of the telescopic boom during maintenance operations of the same or in the areas below it. The boom safety wedge must be installed on the rod of the handler cylinder.

When not in use, the safety wedge (1) is positioned on the telehandler turret through its fixings (1a).



Figure 67: Boom safety wedge

**2.5. OPERATOR AREA****2.5.1 GETTING IN AND OUT OF THE VEHICLE****⚠ WARNING**

The vehicle is equipped with three ladders (front, rear and right side) that allow access to the walkable surface above the vehicle's undercarriage. The ladders must only be used during maintenance operations and only to access the walkable surface.

It is not allowed to use the front, rear or right side ladder to get inside the vehicle cabin.

**⚠ WARNING**

To get in and out of the vehicle, use the access ladder located on the right side of the vehicle (fuel tank area).

The telehandler is equipped with access steps (1) and two handles (2) which are located inside the cabin to facilitate the operator's entry and exit from it.



Figure 68: Getting in and out of the vehicle

**2.5.2 A - DRIVER'S SEAT (STANDARD)**

Designed for maximum comfort, this seat can be adjusted as follows.

Sit in the seat properly.

1. Forward-backward adjustment of the seat, in relation to the control joysticks.  
Pull the lever (1) up.  
Move the seat forward or backward to the desired position, depending on the armrests.  
Release the lever and make sure it returns to the blocked position.

2. Forward-backward adjustment of the seat.  
Pull the handle (2) upwards.  
Move the seat forwards or backwards to the desired position.  
Release the lever and make sure it returns to the blocked position.

3. Tilting seat backrest.  
Pull the lever up (3) and tilt the seat to the desired position.  
Release the lever and make sure it returns to the blocked position.

 *If the backrest is not supported during adjustment, it will tilt all the way forward.*

4. Weight-dependent seat suspension adjustment.  
Depending on the weight of the operator, the excursion of the seat suspension can be varied.  
To do this, use the crank (4) to set the desired value.  
The weight value is displayed in the indicator alongside (4a) the crank (4).  
Release the crank and make sure it returns to the blocked position.

5. Adjusting the seat cushion depth.  
Pull the handle (5) upwards.  
Move the seat to the desired position.  
Release the lever and make sure it returns to the blocked position

6. Adjusting seat cushion forward tilt.  
Pull the handle (6) upwards.  
Move the seat to the desired position.  
Release the lever and make sure it returns to the blocked position

7. Lumbar adjustment of the seat backrest.  
Turn the knob (7) to adjust the lumbar area of the backrest.



Figure 69: Driver's seat (standard)

### 2.5.3 B - PNEUMATIC SEAT FOR DRIVER (OPTIONAL)

Designed for maximum comfort, this seat can be adjusted as follows.

Sit in the seat properly.

Switch on the electrical contact of the telehandler.

1. Forward-backward adjustment of the seat, in relation to the control joysticks.  
Pull the lever (1) upwards.  
Move the seat forward or backwards to the desired position, depending on the armrests.  
Release the lever and make sure it returns to the blocked position.

2. Forward-backward adjustment of the seat.  
Pull the handle (2) upwards.  
Move the seat forwards or backwards to the desired position.  
Release the lever and make sure it returns to the blocked position.

3. Seat backrest tilting adjustment.  
Supporting the backrest, pull the lever upwards (3) and tilt the seat to the desired position.  
Release the lever and make sure it returns to the blocked position.

 *If the backrest is not supported during adjustment, it will tilt all the way forward.*

4. Height and weight adjustment:

- Seat suspension adjustment according to the operator's weight.  
Pull the lever (4) once to self-adjust the seat suspension according to the weight of the operator.  
Release the lever (4).
- Seat height adjustment.  
Keep the lever (4) pulled up or down to vary the seat height.  
Release the lever (4) at the desired height.

5. Blocking lever (5) for suspension adjustment.

6. Seat cushion depth adjustment.  
Pull the handle (6) upwards.  
Move the seat to the desired position.  
Release the lever and make sure it returns to the blocked position

7. Adjusting seat cushion forward tilt.  
Pull the handle (7) upwards.  
Move the seat to the desired position.  
Release the lever and make sure it returns to the blocked position.

8. Lumbar adjustment of the backrest.  
Press the switch (8) to adjust the lumbar support.  
Release the switch (8) in the desired position.

9. Blocking lever (9) for seat forward-backward adjustment.

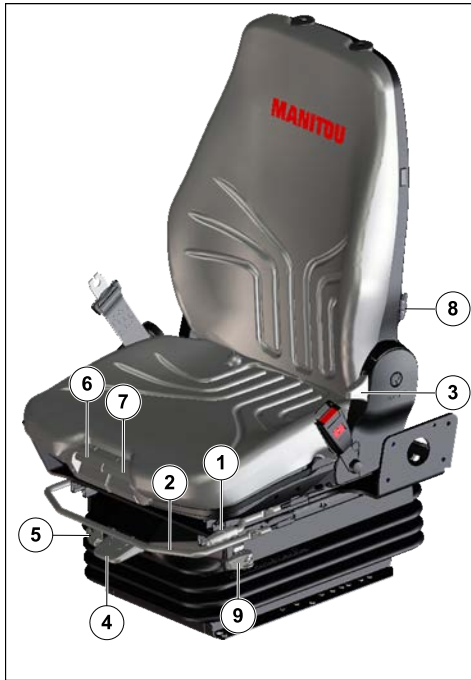

Figure 70: Pneumatic seat for driver (optional)

### 2.5.4 C - HEATED / AIR-CONDITIONED DRIVER'S SEAT (OPTIONAL)

Designed for maximum comfort, this seat can be adjusted as follows.

Sit in the seat properly.

Switch on the electrical contact of the telehandler.

1. Forward-backward adjustment of the seat, in relation to the control joysticks.  
Pull the lever (1) upwards.  
Move the seat forward or backward to the desired position, depending on the armrests.  
Release the lever and make sure it returns to the blocked position.
2. Forward-backward adjustment of the seat.  
Pull the handle (2) upwards.  
Move the seat forwards or backwards to the desired position.  
Release the lever and make sure it returns to the blocked position.
3. Seat backrest tilting adjustment.  
Supporting the backrest, pull the lever upwards (3) and tilt the seat to the desired position.  
Release the lever and make sure it returns to the blocked position.



*If the backrest is not supported during adjustment, it will tilt all the way forward.*

4. Height and weight adjustment:
  - Seat suspension adjustment according to the operator's weight.

Pull the lever (4) once to self-adjust the seat suspension according to the weight of the operator.

Release the lever (4).

- Seat height adjustment.  
Keep the lever (4) pulled up or down to vary the seat height.  
Release the lever (4) at the desired height.
5. Blocking lever (5) for suspension adjustment.
  6. Seat cushion depth adjustment.  
Pull the handle (6) upwards.  
Move the seat to the desired position.  
Release the lever and make sure it returns to the blocked position
  7. Tilting seat cushion forward.  
Pull the handle (7) upwards.  
Move the seat to the desired position.  
Release the lever and make sure it returns to the blocked position.
  8. Lumbar adjustment of the backrest.  
Press the switch (8) to adjust the lumbar support.  
Release the switch (8) in the desired position.
  9. Blocking lever (9) for seat forward-backward adjustment.
  10. Seat heating and air conditioning.  
Press the switch (10) to activate the heating and ventilation of the seat cushion and backrest.
  11. Headrest extension.  
The height of the headrest (11) can be adjusted by pulling it upwards (the grooves will snap into the joints) as far as the stop.  
The headrest (11) can be removed by applying enough pressure to free it from the stop.

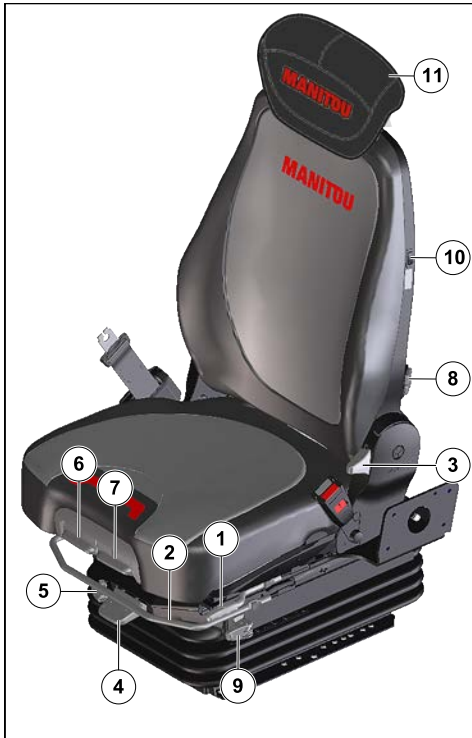

Figure 71: Heated / air conditioned driver's seat (optional)



Figure 72: Seat belt

### 2.5.5 SEAT BELT

Sit in the seat properly.

- Make sure that the belt (1) is not twisted.
- Wear the belt at the level of the pelvis.
- Fasten the seat belt (1) and check that it is securely locked (2).
- Adjust the belt according to your body size, avoiding compressing the pelvis and without excessive play.



*Never use the telehandler with a defective seat belt (fastening, locking, stitching, tearing, etc.). Repair or replace the seat belt immediately.*

### 2.5.6 IGNITION SWITCH

The switch (1) has 4 positions and its features are:

- **0** : STOP heat engine.
- **I** : General electrical contact "+" (also activates the preheating device if installed).
- **II** : Not used.
- **III** : STARTING the heat engine and returning to position "I" after releasing the key (also deactivates the preheating device if installed).



Figure 73: Ignition switch

### 2.5.7 "EASY MANAGER" ANTI-START SYSTEM (OPTIONAL)

"Easy MANAGER" identification keypad

It requires the creation of identification for the operator from the "EasyMANAGER" portal. For more information contact the dealer.

#### OPERATION

##### BY MEANS OF IDENTIFICATION CODE

- Insert the electrical contact on the forklift truck, the LED (1) lights up.
- Enter the identification code and confirm it by pressing the (V) key.
- The LED (2) lights up green to confirm operator identification.
- Switch on the forklift truck immediately, after this period, the identification is canceled and the LED (2) turns red.



*In the event of a typing error, the LED (2) lights up red, press the (X) key and wait 10 seconds before entering the correct identification code.*

##### BY MEANS OF IDENTIFICATION CARD

- Insert the electrical contact on the forklift truck, the LED (1) lights up.
- Show the identification card, a beep confirms the reading of the card.
- The LED (2) lights up green to confirm operator identification.
- Switch on the forklift truck immediately, after this period, the identification is canceled and the LED (2) turns red.

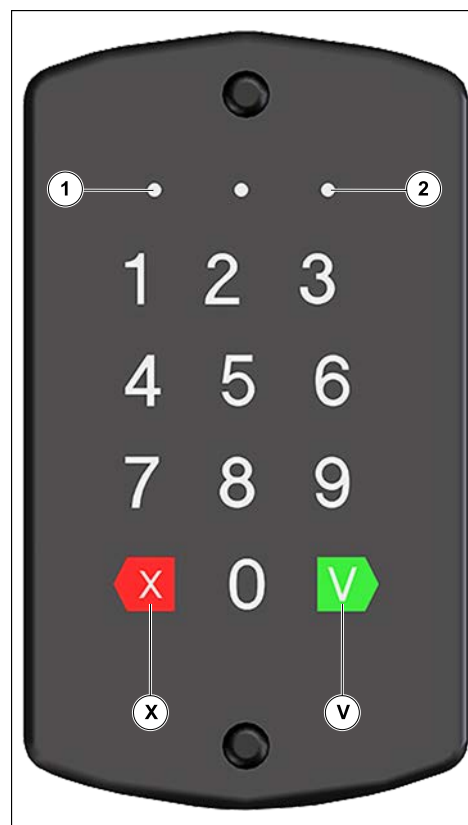

Figure 74: "Easy MANAGER" anti-start system

## 2.6. DISPLAY

### 2.6.1 DISPLAY CONTROL

#### INFORMATION SCREEN OF HMI NAVIGATOR

(human machine interface)



*The contents of the "SETTINGS" and "DIAGNOSTICS" menus vary according to the equipment of the telehandler.*

##### 1. ROTARY KNOB WITH CONFIRMATION BUTTON.

The knob rotates clockwise and counterclockwise.

Turn the knob to scroll the buttons on the pages and navigate within them (if possible), press the knob to confirm your preferences.

Turning the knob (1) activates the highlighting and moves it to elements on the page.

On each page, activation starts from the MENU button (bottom bar, left side).

By turning the knob (1) clockwise, the highlight will move to the shortcuts and then to the screen above.

By turning the knob (1) counterclockwise, the highlight will move to the top area and then to the bottom screen.

Once activated, section highlighting will start from the first element at the top / left of the selected area.

2. SETTINGS PAGE

Briefly press the button (2) to display the "SETTINGS" page.

Turn the knob (1) to navigate on the page and the sub-menus.

Press the knob (1) to confirm your preference.

3. DIAGNOSTICS PAGE

Briefly press the button (3) to display the "DIAGNOSTICS" page.

Turn the knob (1) to navigate the menu and sub-menus.

Press the knob (1) to confirm your preference.

4. BACK BUTTON

Briefly press the button (4) to return to the previous screen.



Figure 75: Display control

















2.6.2 DISPLAY ICONS

















Overview of symbols and features:

Table 77. Indicators

| INDICATORS |                        |
|------------|------------------------|
|            | Sidelights             |
|            | Dipped beam headlights |
|            | Main beam headlights   |

| INDICATORS |  |
|------------|--|
|            | Rear fog lamp  |
|            | Indicator lights   |
|            | Telescopic handler door open   |
|            | Seat belt not fastened   |
|            | Engine coolant temperature   |
|            | Fuel Reserve (Fuel level less than 10% of tank capacity)   |
|            | Hydraulic oil temperature (Blue indicator on, the temperature is low: below 20°)   |
|            | Turret position aligned with the undercarriage (depending on machine model)  |
|            | Turret aligned with the forklift truck and turret rotation pin inserted. Turret rotation blocked. (Depending on Machine Model) |
|            | Turret in front position (Depending on machine model)  |
|            | Turret in rear position: Reverse steering (Depending on machine model)   |
|            | Front wheel alignment  |
|            | Rear wheel alignment   |
|            | Front wheel drive (Driving on road)  |
|            | Opposite direction forward and backward wheel steer (Small turning radius)   |
|            | Front and rear wheel drive in the same direction (lateral movement)  |

| INDICATORS  |   |
|---|---|
|    | Rear axle block   |
|    | Low gear engaged (Depending on machine model)   |
|    | High gear engaged (Depending on machine model)  |
|    | Automatic gear (Depending on machine model)   |
|    | Diesel exhaust fluid (DEF) tank level   |
|    | Emission-related malfunction of the exhaust after-treatment system or of the DEF supply |
|    | Approval of regeneration of the DPF filter  |
|   | DPF filter regeneration required  |
|  | DPF filter regeneration disabled by the operator  |
|  | Active regeneration and high temperature of the exhaust gas                             |
|  | Active suspension (Depending on machine model)  |
|  | Mid suspension (Depending on machine model)   |
|  | Suspension fully lowered (Depending on machine model)                                   |
|  | Fully raised suspension (Depending on machine model)                                    |
|  | Platform movement in operation  |
|  | Platform movement in operation  |

| INDICATORS  |  |
|---|--|
|    | Maximum moving speed adjustment                            |
|    | Heat engine RPM adjustment                                 |
|    | Continuous optional (Oil flow % setting)                   |
|    | Radio control (Optional)                                   |
|    | 2nd optional in operation (Optional)                       |
|    | 3rd optional in operation (Optional)                       |
|    | Maintenance interval                                       |
|   | 4 braking power levels of the magnetic retarder (Optional) |
|  |  |
|  |  |
|  |  |
|  | Bi-energy system status (Optional)                         |
|  |  |
|  |  |
|  |  |
|  |  |
|  |  |

| INDICATORS |  |
|------------|--|
|            |  |

Table 78. Warning lights

| WARNING LIGHTS |  |
|----------------|--|
|                | Serious heat engine failure                              |
|                | Heat engine malfunction                                  |
|                | Alternator excitation                                    |
|                | Heat engine oil pressure                                 |
|                | Engine air intake filter                                 |
|                | Transmission oil filter                                  |
|                | Hydraulic oil filter                                     |
|                | Parking brake on   |
|                | Low brake oil pressure                                   |
|                | Red warning light for disabling the load limiter         |
|                | DANGER! Red warning light for disabling the load limiter |

Table 79. Icons

| ICONS |   |
|-------|---|
|       | Eco fuel mode (Lit blue or yellow in operation)               |
|       | Drive & Handling shift mode (Lit blue or yellow in operation) |
|       | Eco mode Stop heat engine (Lit blue or yellow in operation)   |

| ICONS |   |
|-------|---|
|       | Eco fuel mode (Lit blue or yellow in operation)               |
|       | Drive & Handling shift mode (Lit blue or yellow in operation) |

### 2.6.3 DISPLAY PAGES

The color screen display (1) shows and informs the operator about all the work phases of the telehandler.

Different control modes stored in the display memory (1) can be selected on touchscreen or via the “HMI” navigator (2) on the right armrest (3) in the cabin.



Figure 76: Display control mode

Upon startup, the HMI shows the Manitou startup animation for 10 seconds while waiting for the application to be ready.

The Manitou logo appears 1 second after the dashboard is activated.



Figure 77: HMI start

The fixed features of the HMI areas are:

- The information bar (1).
- The warning lights and indicators (2a), the load status bar (2b).
- Audio playback in progress (3).
- The button bar (4).
- The top (5) and bottom (6) may be different in relation to the activity shown.

Overview:

- Information bar area (1):  
it contains the outdoor temperature, configuration and time.
- Warning lights and indicators area (2a), the load status bar (2b):  
it contains the warning lights or indicators, the errors activated, the load status bar, the status of the selector that disables the anti-tipping system and the type of attachment connected.

- Load status bar (2b) indicates the percentage of load lifted with respect to the maximum load that can be lifted in those working conditions:
  - Green part: Safety Zone.
  - Yellow part: Alarm zone. Lifted load greater than 90% of the permissible load (external acoustic signal enabled).
  - Red part: Blocking zone. Lifted load greater than 100% of the permissible load (external horn active).
- Top (5):  
contains the main view and the bars of the selected page.
- Bottom (6):  
contains touch integration which causes changes at the top.
- Repetition area (3):  
multimedia or radio information.
- Button bar area (4):  
it contains the main menus of the HMI, man-machine interface.



Figure 78: HMI area

### 2.6.4 BUTTON BAR

- MENU (Main Functions) (A)
- HEATING and AIR CONDITIONING (optional) (B)
- MULTIFUNCTION (C)
- FM RADIO / DAB / USB & PHONE MANAGEMENT (D)
- REAR CHAMBER (E)

Briefly press the button to access the content.

Select a button (B, C, D, E) of the bar (4), the button is highlighted and the content is opened at the bottom of the screen.

Select button (A) to open the drop-down menu on the left side of the screen (see MENU PAGE).

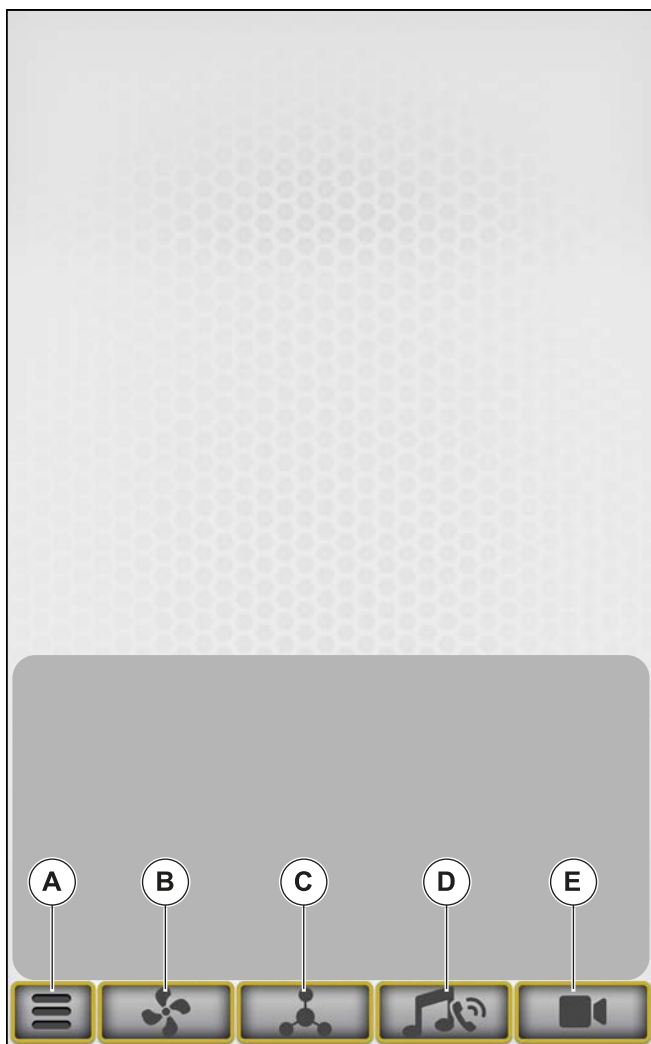

Figure 79: Button bar

#### B - OPTIONAL HEATING AND AIR CONDITIONING BUTTON

Briefly press the button to access the cabin ventilation panel.

The panel can contain two configurations:

- Heating.
- Air conditioning (optional).

Briefly press the touch buttons to enable or disable the features.

Table 80. Overview buttons icons

| Icon | Description  |
|------|--|
|      | Ventilation direction: <ul style="list-style-type: none"> <li>• - Air vents</li> <li>• - Glass demisting diffusers.</li> </ul> |
|      | Air recirculation  |
|      | Max windshield defrost<br>(Only with Air Conditioning)   |
|      | Air conditioning ON / OFF<br>(Only with Air Conditioning)  |
|      | Automatic control<br>(Only with Air Conditioning)  |
|      | Ventilation panel ON / OFF   |
|      | Rear window heater   |
|      | Exterior rear view mirror heater   |
|      | Foot mat heater  |
|      | Temperature regulation:<br>+ = Increase speed<br>- = Decrease speed  |
|      | Fan speed adjustment:<br>(10 speeds available)<br>+ = Increase speed<br>- = Decrease speed                                     |

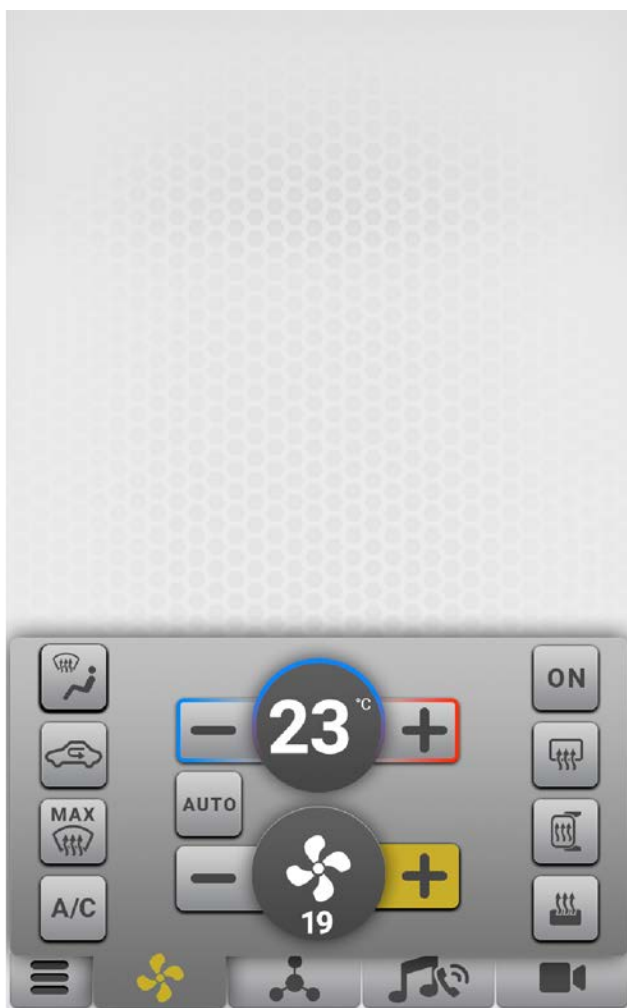

Figure 80: Heating and Air Conditioning button (Optional)

## C - MULTI-FEATURE BUTTON

Press the button briefly to access some features of the rotating telehandler.

Briefly press the controls to enable or disable the features.

Table 81. Icons overview

| Icon | Description  |
|------|--|
|      | Work lights at the top of the telescopic boom (optional) |
|      | Front cabin work lights (optional)                       |
|      | Corner light (optional)                                  |
|      | Rear, roof and side wipers, intermittent activation      |

| Icon | Description   |
|------|---|
|      | Rear cabin work light   |
|      | Request intermediate suspension height position (keep the button pressed) |
|      | Suspension activation request (briefly press the button)                  |

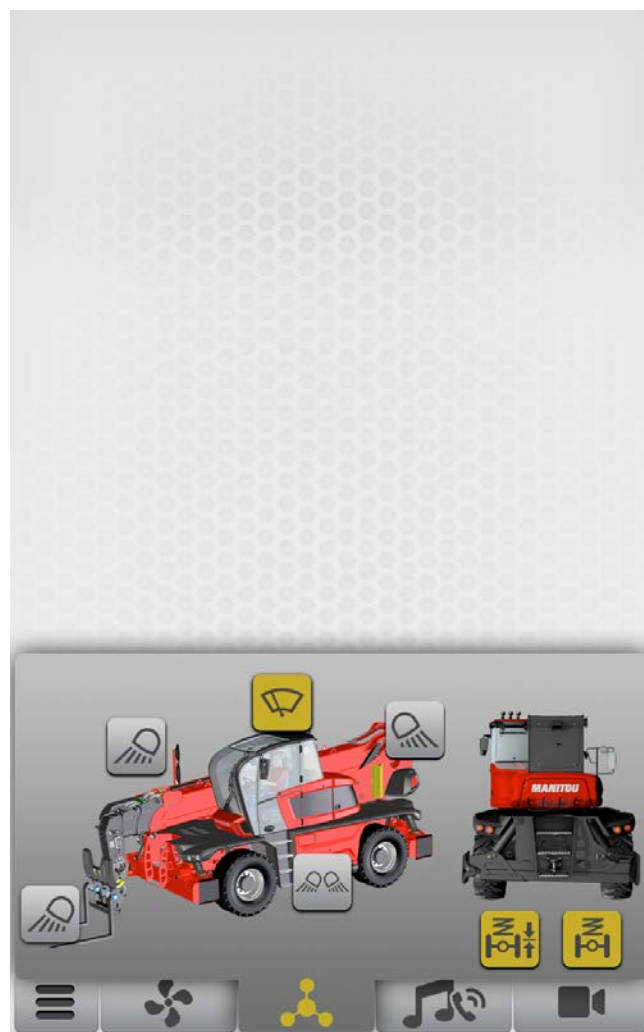

Figure 81: Multi-feature button

## D - FM RADIO / DAB / USB & PHONE MANAGEMENT

Briefly press the button to access the management screen of RADIO, USB, BLUETOOTH, TELEPHONE features. The button is highlighted.

Press the buttons briefly to enable the features. Selected buttons or enabled features are highlighted.

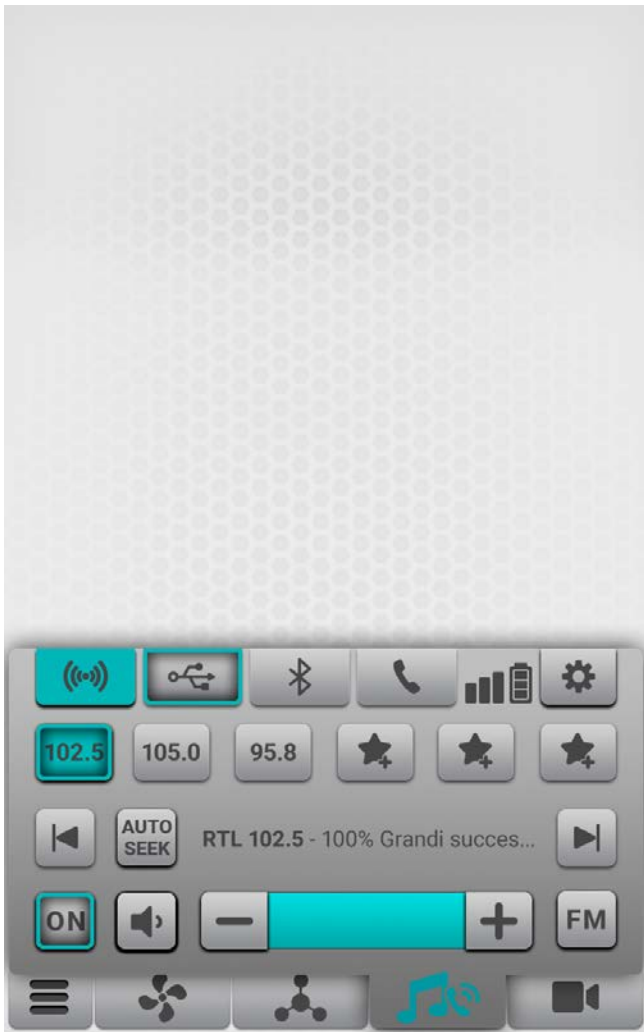

Figure 82: Radio management button

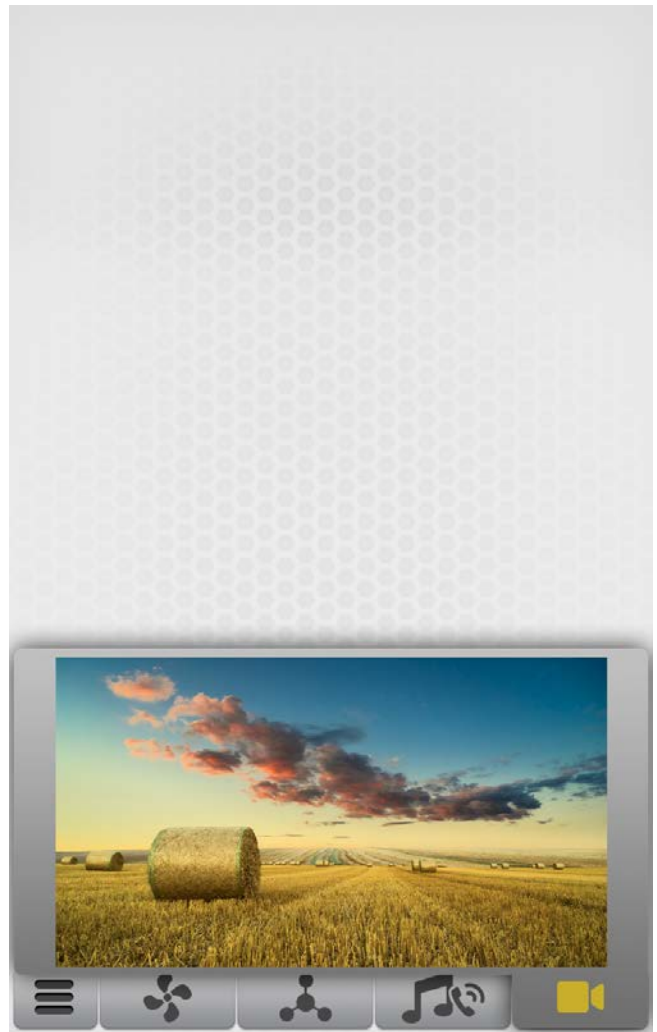

Figure 83: Rear camera

**E - REAR CAMERA**

Briefly press the touch screen button to access the screen. The button is highlighted.

The camera shortcut can be shown at the operator's request or during reverse gear activation.

The camera shows the rear of the rotating telehandler.

**2.6.5 MENU PAGES**

Overview:

1. "DRIVE" PAGE
2. "WORKING" PAGE
3. "STABILITY" PAGE
4. "ADJUSTMENTS" PAGE
5. "DIAGNOSTICS" PAGE
6. "SETTINGS" PAGE
7. "RESOURCES" PAGE
8. "INFORMATION" PAGE

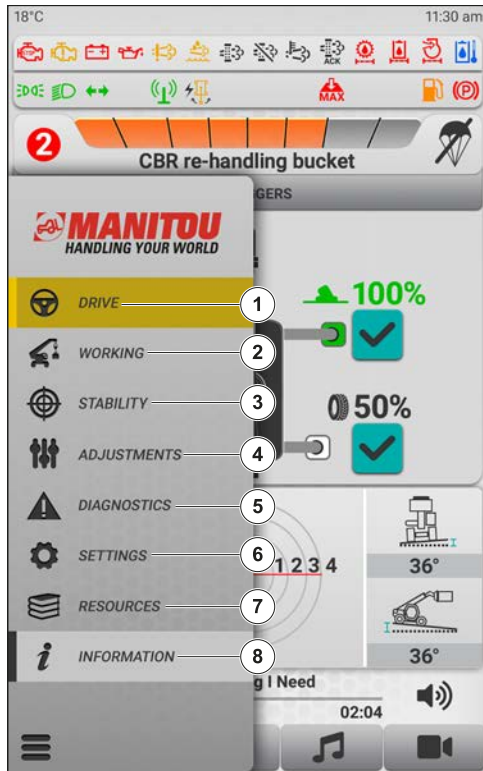

Figure 84: Menu Pages

### 2.6.6 "DRIVE" PAGE

The "DRIVE" page displays the main information related to driving.

The main information in the upper area relates to levels and actual values:

1. Tachometer (x100 rpm) (1).
2. Speedometer (km / h or mph) (2).
3. Engine coolant temperature gauge (3).
4. Diesel exhaust fluid (DEF) level gauge that provides information on the amount of DEF in the tank (4).
5. Fuel level gauge (5).
6. Hydraulic oil temperature gauge (6).
7. Forward - reverse direction indicator (7).
8. Total hours meter (8).
9. Partial hour meters (9).
10. Consumption (10).

The main information in the lower area relates to engine and transmission settings:

11. Setting the maximum speed of the rotating telehandler (11).
12. Engine revs setting (rpm) (12).
13. Continuous adjustment of the oil flow of the attachment line (13).

14. ECO STOP button (14) Enabling this feature allows the engine to stop after a certain time interval. Briefly press the button to enable or disable the feature. Once the button is pressed, it is highlighted.
15. "HANDLING" driving mode (15) This feature allows you to select the "HANDLING" driving mode: for handling loads in the work area. Briefly press the button to enable or disable the feature. Once the button is pressed, it is highlighted to indicate that the feature is active.
16. ECO MODE (16) Enabling this feature allows you to reduce fuel consumption if the driving speed is kept constant. Briefly press the button to enable or disable the feature. Once the button is pressed, it is highlighted.
17. Regeneration request button (17) Keep the button pressed to enable the feature. Once the button is pressed, it is highlighted.
18. Regeneration inhibition button (18) Press the button briefly to enable the feature. Once the button is pressed, it is highlighted.
19. Engine override feature button (19) Press the button briefly to enable the feature. Once the button is pressed, it is highlighted.

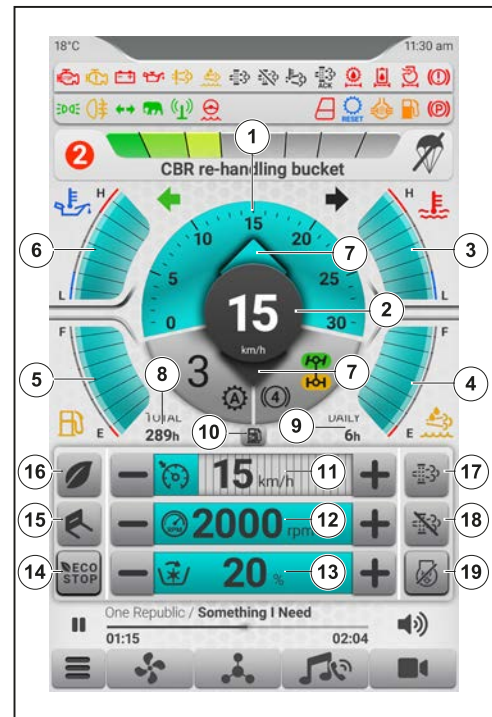

Figure 85: "DRIVE" page

### 2.6.7 "WORKING" PAGE

The "WORKING" page displays the main information of the telehandler and the reading of the main working data.

Furthermore, on the "WORKING" page, you have the possibility to select three tabs, one at a time, from the tab bar (4), at the top of the screen.

Always displayed in the central area of the screen is the load chart inherent to the attachment connected to the telescopic handler which changes automatically according to the working condition of the machine, stabilized or on tires.

Tab overview:

- **GEOMETRICAL:** Displays the chart and geometric values of the vehicle.
- **DIAGRAM INFO (LOAD CHART):** displays the complete chart without geometric values.
- **SIMULATOR:** displays and allows a simulation of maximum load.

"GEOMETRICAL" tab:

- Maximum permissible load.
- Weight of the lifted load.
- Length of the telescopic boom.
- Ground clearance.
- Telescopic boom angle.
- Working range.
- Turret angle.
- Coupling angle.
- Vehicle tilt angle.
- Position of the stabilizers.

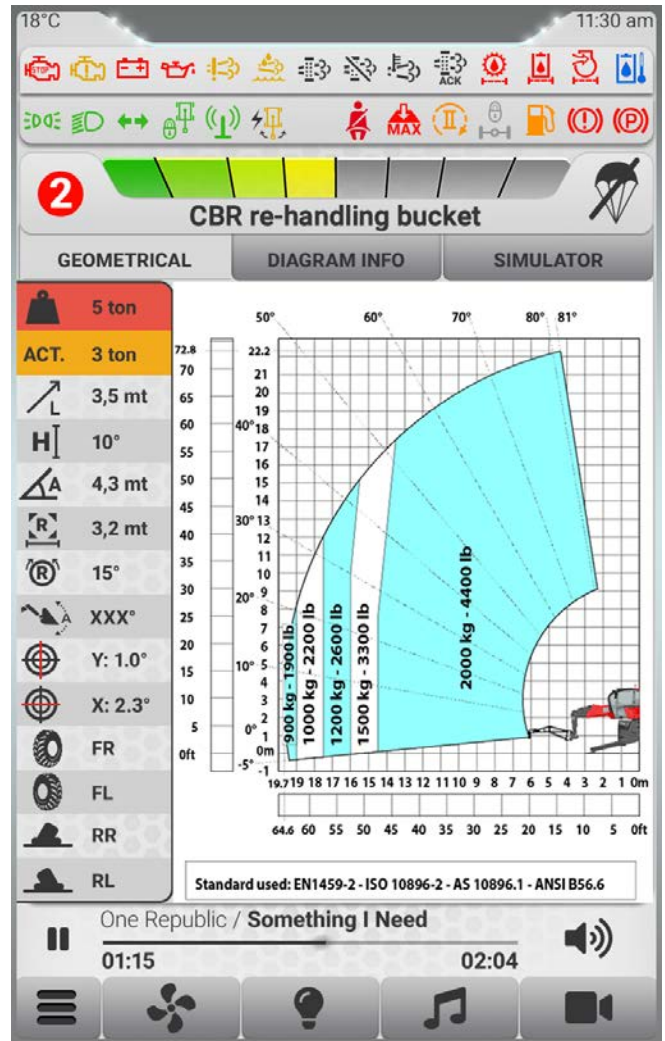

Figure 86: "GEOMETRICAL" tab

"DIAGRAM INFO" tab

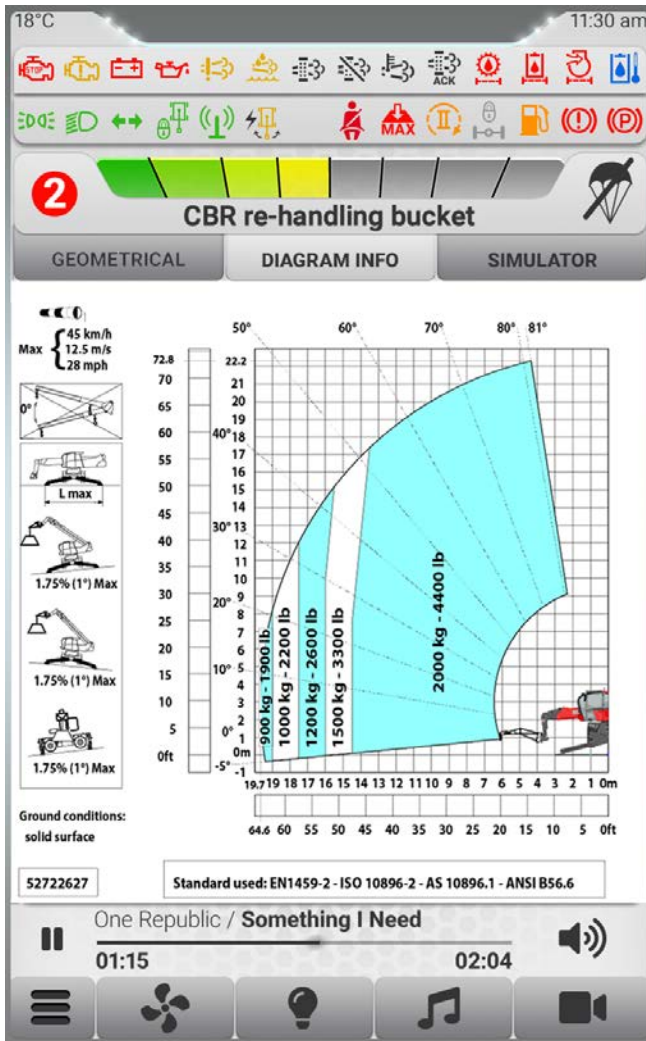

Figure 87: "DIAGRAM INFO" tab

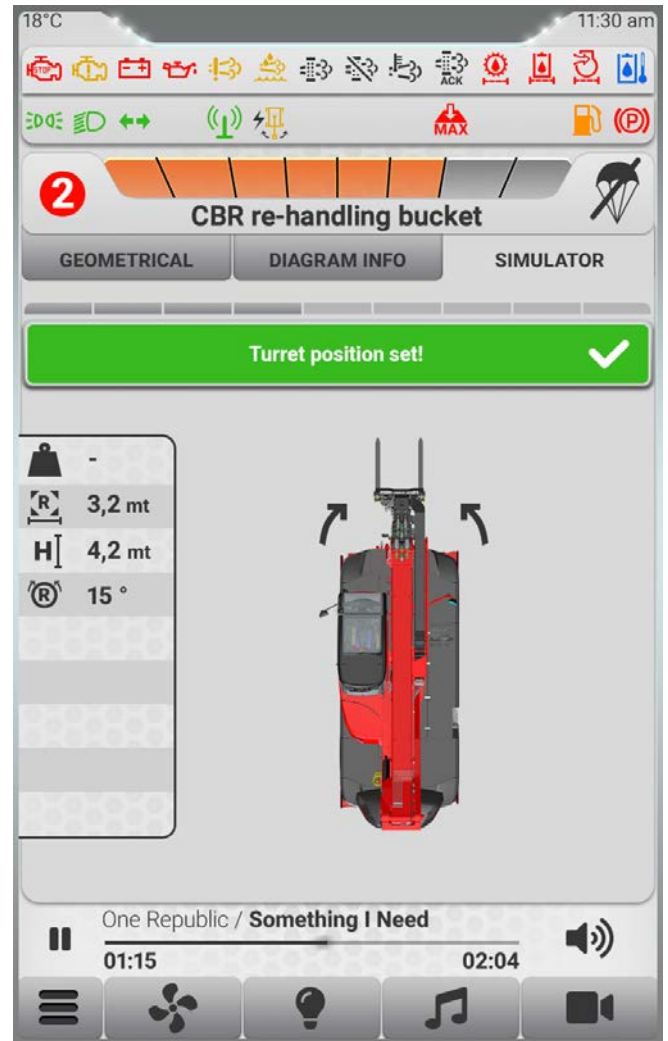

Figure 88: "SIMULATOR" tab

"SIMULATOR" tab

## 2.6.8 "STABILITY" PAGE

The "STABILITY" page displays the main information of the telehandler and the reading of the main working data regarding the stabilizers and the chassis.

On the page it is possible to manage the selection of stabilizers and automatic leveling.

The upper area displays the main information relating to the selection of the stabilizers, one by one or all or none, their position and their status.

This operation is linked to the control buttons on the right armrest of the driver's seat.

The position and status of each stabilizer are shown by the percentage of extension (%) and by the status (on tire or on the ground).

Displayed at the bottom is the main information relating to the chassis.

The information displayed relates to the tilt of the chassis and the request for the self-leveling control.

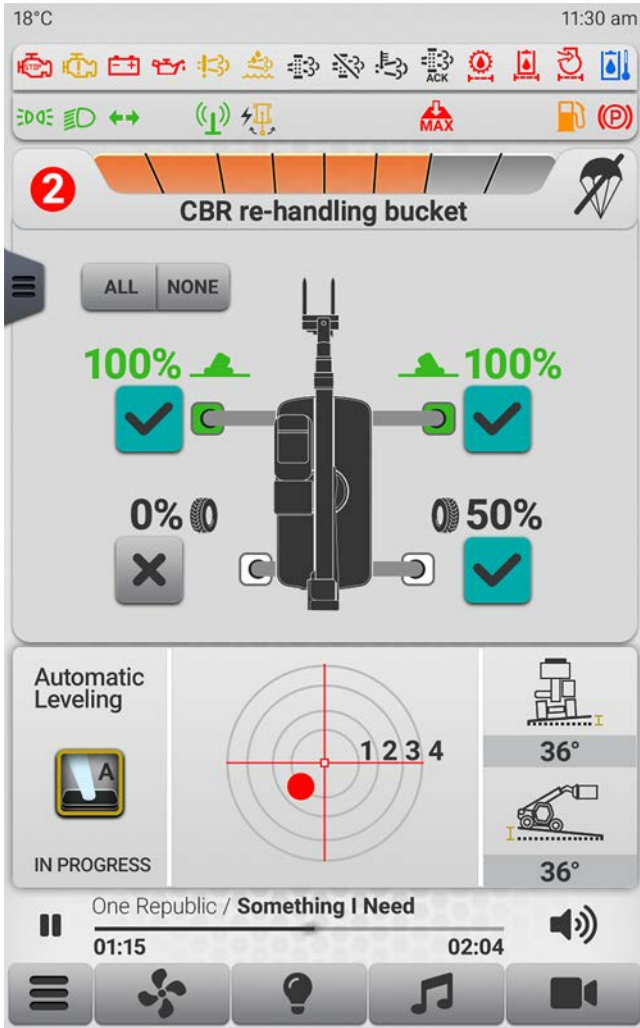

Figure 89: "STABILITY" page

### 2.6.9 "ADJUSTMENTS" PAGE

The "ADJUSTMENTS" page displays the main information regarding the geometric limits and the slowed speed of the hydraulic movements and for this it is necessary to select two tabs, one at a time, from the tab bar at the top of the screen.

Tab overview:

- **LIMIT (LIMITS):** displays and allows for setting geometric limits parameters. This feature allows you to set an operational limit in a work area.
- **SLOWING DOWN:** displays and allows you to set the maximum speed parameters of the hydraulic movements.

"LIMIT" tab:

- "Corridor" workspace.
- "Wall" workspace.
- "Roof" workspace.

The top displays the geometric limit set.

The bottom allows you to modify and enable / disable the feature.

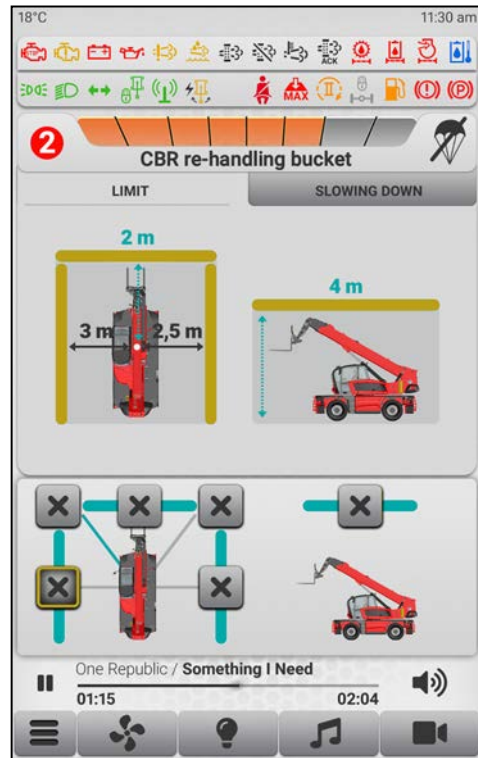

Figure 90: "LIMIT" tab

"SLOWING DOWN" tab:

- Maximum speed of ascent of the telescopic boom.
- Maximum speed of descent of the telescopic boom.
- Maximum extension speed of the telescopic boom.
- Maximum retraction speed of the telescopic boom.
- Maximum tilt-up speed of loads.
- Maximum tilt-down speed of loads.
- Maximum hourly rotation speed of rotating turret.
- Maximum counterclockwise rotation speed of the rotating turret.
- Maximum speed of control of the movements of the attachment: up, clockwise rotation, to the right, tilt up (depending on the attachment installed).
- Maximum speed of control of the movements of the attachment: descent, anticlockwise rotation, to the left, tilt down (depending on the attachment installed).

The maximum control speed of the hydraulic movements is expressed as a percentage: from 100% to 0%.

It is possible to set and save two working systems. Furthermore, it is possible to set the maximum control speed of the hydraulic movements by briefly pressing the "MAX" button.



Figure 91: "SLOWING DOWN" tab

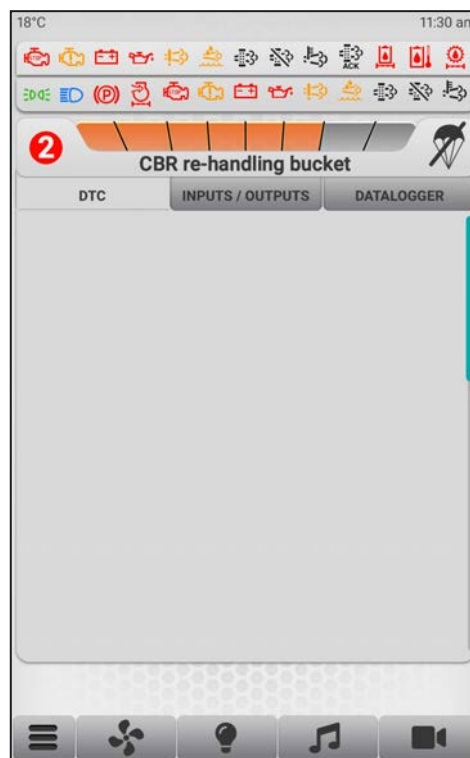

Figure 92: DTC tab

### 2.6.10 "DIAGNOSTICS" PAGE

The "DIAGNOSTICS" page displays the main information relating to the active errors of the telehandler, with control unit, DTC code and occurrences.

You need to select three tabs, one at a time, from the tab bar at the top of the screen.

You can press on the error line to view its description, a pop-up window will open.

Tab overview:

- DTC (information about engine errors).
- INPUT / OUTPUTS.
- DATALOGGER (information about the CODE, date and transition).

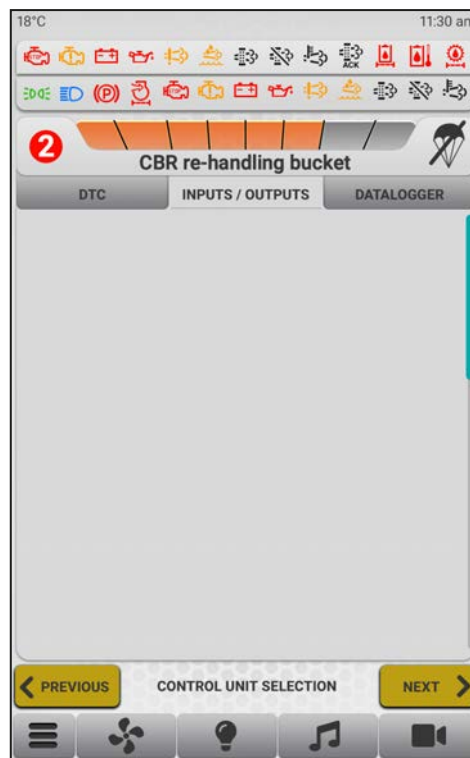

Figure 93: INPUT / OUTPUTS tab



Figure 94: DATALOGGER tab

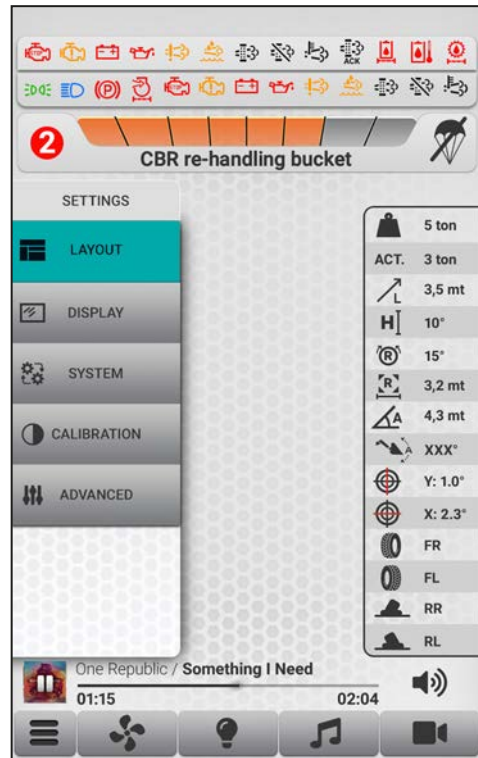

Figure 95: "SETTINGS" page

### 2.6.11 "SETTINGS" PAGE

The "SETTINGS" page displays the main information set by the factory or by the operator relating to the "HMI" display.

The "SETTINGS" menu information is visible on the left side of the screen and is highlighted when selected.

The operator can display and change three settings.

Table 82. "SETTINGS" menu overview

| Menu    | 1st submenu         | 2nd submenu          |
|---------|---------------------|----------------------|
| LAYOUT  | Graphics            | Day / Night / Auto   |
|         | Color               | Blue / Yellow        |
|         | Unit of measure     | Metric / Imperial    |
|         | Temperature         | Celsius / Fahrenheit |
| DISPLAY | Brightness          | 0-100%               |
| SYSTEM  | Language            | IT, EN, FR, etc.     |
|         | Clock               | Top right value      |
|         | Partial hours reset |                      |
|         | Attachments list    |                      |

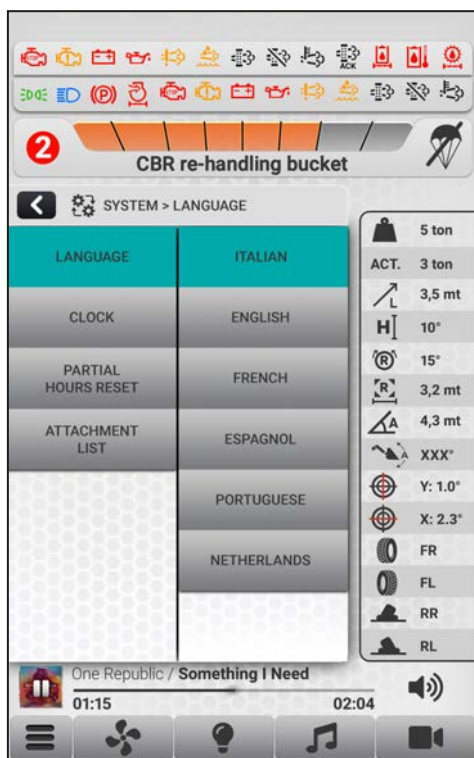

Figure 96: Example of "SYSTEM" submenu



Figure 97: Example of "Night" graphic screen



Figure 98: Example of "Yellow" color screen

## 2.6.12 "RESOURCES" PAGE

The "RESOURCES" page (ADDITIONAL RESOURCES) displays the main information relating to the documentation useful to the operator.

RESOURCES menu overview:

- DOCUMENTS
- VIDEOS
- TUTORIAL DISPLAY
- USER MANUAL

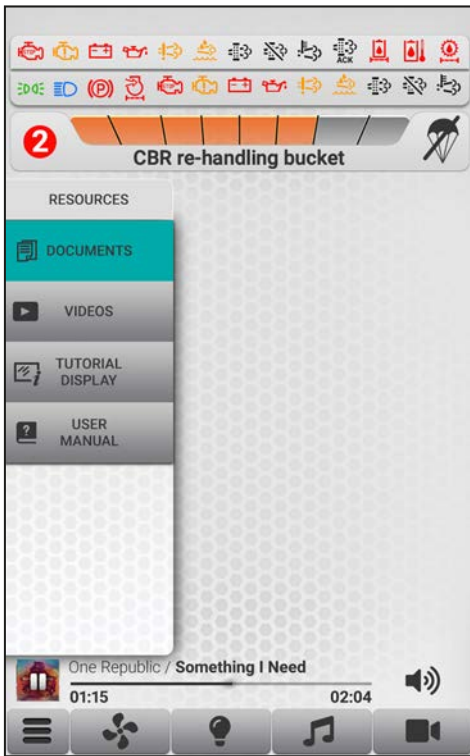

Figure 99: "RESOURCES" page

### 2.6.13 "INFORMATION" PAGE

The "INFORMATION" page displays the main information regarding the software version, the version of the load charts and the attachments list.

you need to select two tabs, one at a time, from the tab bar at the top of the screen.

INFORMATION tabs overview:

- VEHICLE INFO
- ATTACHMENTS (ATTACHMENT INFORMATION)

"VEHICLE INFO" tab, displays information about the software version:

- Load charts.
- LMI version.
- Main version.
- HMI version.
- Aux version.
- Aux 2 version.

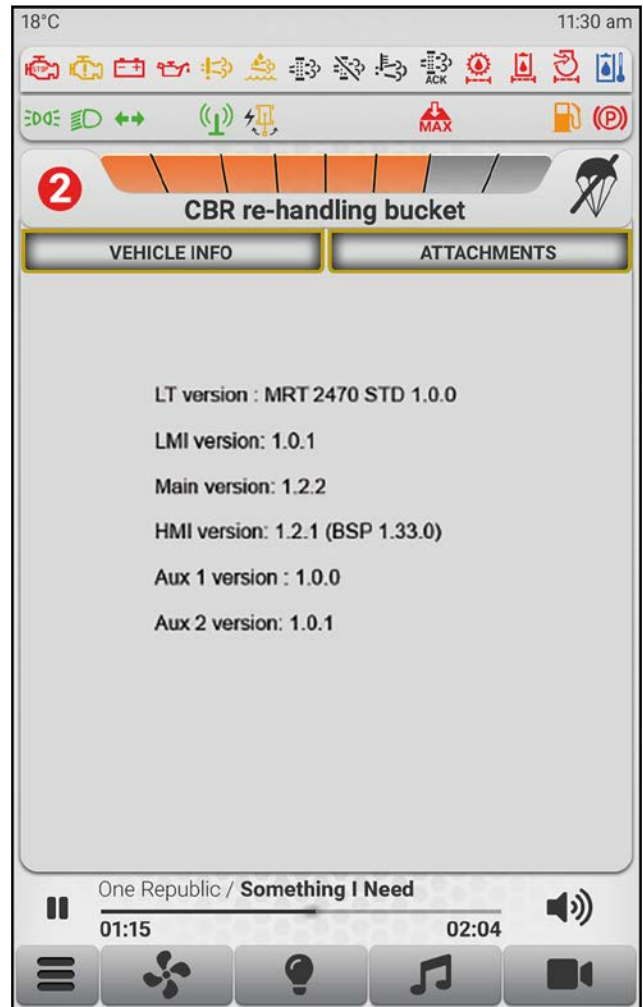

Figure 100: "VEHICLE INFO" tab

"ATTACHMENTS" tab, displays the information relating to the list of attachments available in the flashing load table:

- Index
- Attachment name
- Acronym



Figure 101: "ATTACHMENTS" tab

## 2.7. CHECK INDICATORS

### 2.7.1 JOYSTICK

The telehandler is equipped with two proportional electro-hydraulic capacitive joysticks, one to the right (1) of the operator and one to the left (2) both on the seat armrests to ensure better control and comfort.

 *The joysticks only work when grasped and with the cabin door closed or the cabin door open and the seat belt fastened.*

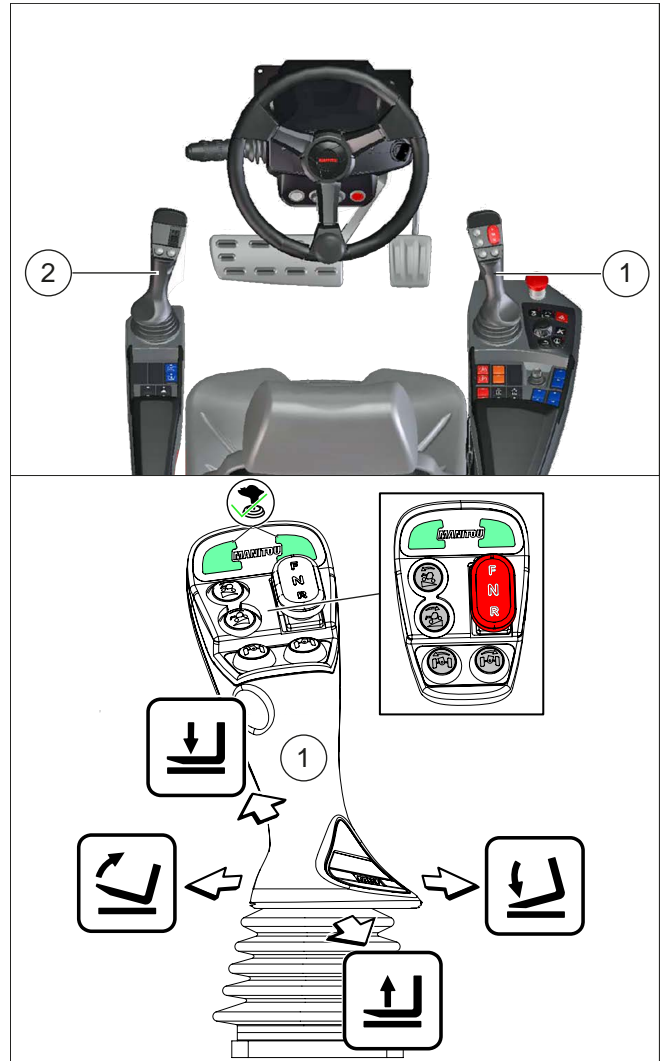

Figure 102: Right joystick

#### Joystick (1)

It can simultaneously carry out two double effect movements: lifting the load and tilting the forks.

To enable and perform the movements, hold the joystick.



To lift the load, pull the lever back.



To lower the load, push the lever forward.

To tilt the fork down, push the lever to the right.

To tilt the fork up, push the lever to the left.

Table 83. Selector overview

|   |   |
|---|---|
|   | Vertical buttons: Machine leveling forward and backward (depending on machine model). |
|    | Horizontal buttons: Lateral machine leveling to the left and right.                   |

|   |  |
|---|--|
|  |  |
|  | Green LEDs lit on joystick, hydraulic movements enabled. |
|  | Direction selector: Forward / Neutral / Reverse.         |

**Joystick (2)**

It can carry out three double effect movements simultaneously:

- Extension of the telescopic boom.
- Rotation of the turret.
- Control of the attachment.

To enable and perform the movements, grab the joystick.

To extend the telescopic boom, push the lever forward.

To retract the boom, pull the lever back.

To rotate the turret clockwise, push the lever to the right.

To rotate the turret counterclockwise, push the lever to the left.

To control the movements of the attachment, rotate the roller on the lever (2).

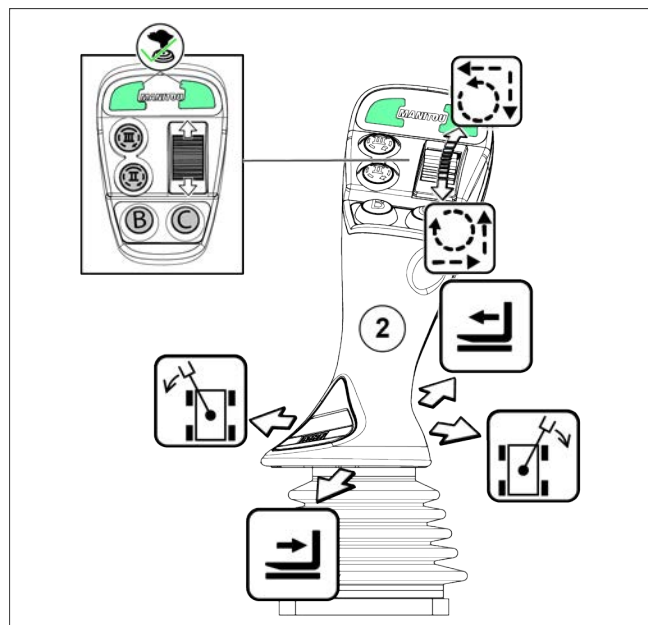







Figure 103: Left joystick

Table 84. Selector overview

|   |  |
|---|--|
|  | Vertical buttons: 2nd and 3rd hydraulic output at the boom head to select several movements of an attachment (optional). |
|  |  |
|  | Horizontal buttons: these select multiple movements of a platform (if available).  |
|  |  |
|  | Green LEDs lit on joystick, hydraulic movements enabled.   |

**2.7.2 BUTTONS AND CONTROLS**



**BUTTON FEATURES**

- Red button: safety.
- Orange button: Transmission / engine.
- Blue button: hydraulic system.
- Black button: other.





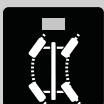

**BUTTON DIAGNOSTICS**



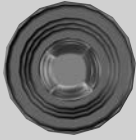
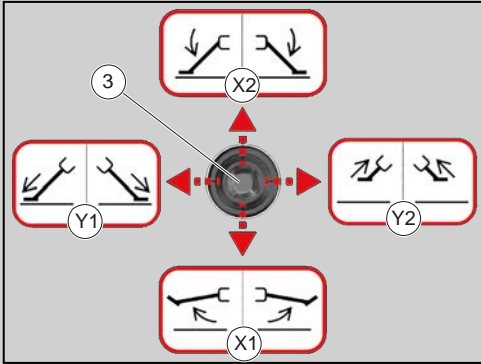





- If all buttons are off, there is a power supply problem, contact your dealer.
- If all buttons are flashing simultaneously, there is a connection problem, contact your dealer.

Table 85. BUTTONS OVERVIEW

| <b>Right armrest</b>  |  |
|---|--|
|    | Navigation and confirmation knob                                     |
|    | Preferences menu   |
|    | Information menu   |
|    | Back   |
|    | Exclusion of hydraulic movements                                     |
|  | Beacon   |
|  | Hazard warning lights  |
|  | Automatic parking brake "manual mode"                                |
|  | Automatic parking brake  |
|  | Travel safety system reset   |
|  | Emergency pump (only with platform)                                  |
|  | Opposite direction front and rear wheel drive (small turning radius) |

| <b>Right armrest</b>  |   |
|---|---|
|    | Front wheel drive (driving on road)                                       |
|    | Front wheel drive and rear wheel drive angle block                        |
|    | Front and rear wheel drive in the same direction (lateral movement)       |
|    | Left front and rear stabilizer selectors                                  |
|    | Right front and rear stabilizer selectors                                 |
|   | Automatic vehicle stabilization selector                                  |
|  | "Emergency stop" button   |
|  | Magnetic retarder to increase vehicle speed deceleration force (optional) |
|  | Magnetic retarder to decrease vehicle speed deceleration force (optional) |
|  | Low / high gear selector  |
|  | Automatic gear change   |

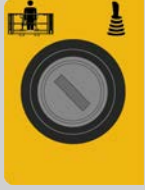
| <b>Right armrest</b>  |  |
|---|--|
|    | Stabilizer control joystick                    |
| <p style="text-align: center;"><b>The movement of the stabilizers is possible through the small joystick (3) located on the right armrest. Move the Joystick:</b></p> <ul style="list-style-type: none"> <li>• back to raise the stabilizers (X1)</li> <li>• forward to lower the stabilizers (X2)</li> <li>• to the left to extend the stabilizers (Y1)</li> <li>• to the right to retract the stabilizers (Y2)</li> </ul> |  |
|    |  |
| <b>Left armrest</b>   |  |
|    | Boom suspension (optional)                     |
|    | Forced boom suspension (optional)              |
|    | Upward suspension (depending on machine model) |
|    | Upward suspension (depending on machine model) |
|    | Disabling the forks tilt control               |
|    | Disabling the attachment control               |

| <b>Left armrest</b>   |  |
|---|--|
|    | Hydraulic block of the attachment  |
|    | Flow limiter of the attachment circuit for continuous hydraulic movement of the attachment |
|    | Seat tilt forward (optional)   |
|    | Seat tilt back (optional)  |
| <b>Steering column</b>  |  |
|   | Button for enabling radio control  |
|  | Safety system exclusion key  |
|  | Control selector from cabin or from platform   |
|  | Red button for recovering the cab controls from the platform in the event of a stop        |
| <b>Canopy (right side)</b>  |  |
|  | Electric adjustment of the right door mirror (telescopic boom side)                        |

### 2.7.3 SAFETY SYSTEM EXCLUSION KEY

The telehandler is equipped with an electronic safety system (MSS) which controls machine overload during work.

The system intervenes automatically by blocking the movements of the telescopic boom.

**⚠ DANGER**

#### Risk of vehicle overturning

With the MSS safety system off, the operator and telehandler are exposed to overload and / or tipping over of the vehicle.

Manually switch off the MSS only in exceptional cases and for safety reasons.

#### Key selector

To disable the MSS safety system, the operator must turn a key switch (1) in the cabin.

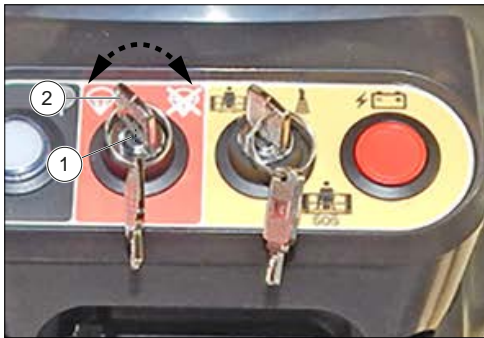



Figure 104: Key selector

The key (2) is stored inside a safety box (3) located behind the driver's cabin.



Figure 105: Safety box

The key selector (1) has two positions:

- Security system enabled 
- Security system disabled 

When in service, the key selector (1) (2) is turned to

position : MSS safety system enabled.

### 2.7.4 STANDARD RADIO CONTROL FOR ATTACHMENT HANDLING

The radio control consists of:

1. Transmitter (push button panel) (1).
2. Receiver (2).



Figure 106: Radio control

3. Battery charger (3) and battery (3a).
4. Transmitter unit support (4) positioned in the cabin, behind the operator's seat.
  - Release the safety block (4b) to raise the boom (4a) that holds the transmitter unit (1) on the support (4).

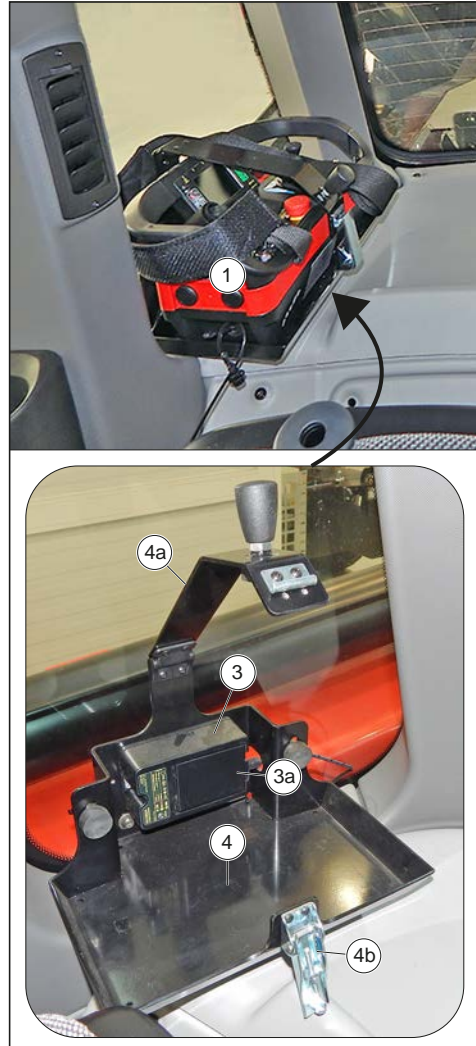

Figure 107: Transmitter unit and support

### Radio control identification

The serial number (SN) is the only reference that must be used to uniquely identify the radio control both in case of maintenance interventions and in case of declarations to concerned bodies.

The serial number (SN) and other information relating to the radio control are found on some plates both in the transmitter and in the receiver.

These plates must not be:

- Removed from their position (removal entails the immediate forfeiture of the warranty).
- Altered or damaged (contact MANITOU for replacement).

### Transmitter unit plates

There are three plates in the transmitter unit:

1. Identification plate of the radio control.  
Information contained: the serial number of the radio control (SN), a QR code and the year of manufacture.
2. Transmitter unit identification plate.

Information contained: the year of manufacture, a QR code and the identification number of the transmitter unit (TU ID).

### 3. Technical data plate.

Information contained: The Model, the Type and the main technical data of the transmitter unit, the marking and any trademarks of the radio control.

## Receiver unit plates

There are two plates on the receiver unit:

### 1. Receiver unit identification plate.

Information contained: The serial number (SN) of the radio control, a QR code and the year of manufacture.

### 2. Technical data plate.

Information contained: The Model, the Type and the main technical data of the receiver unit, the marking and any trademarks of the radio control.

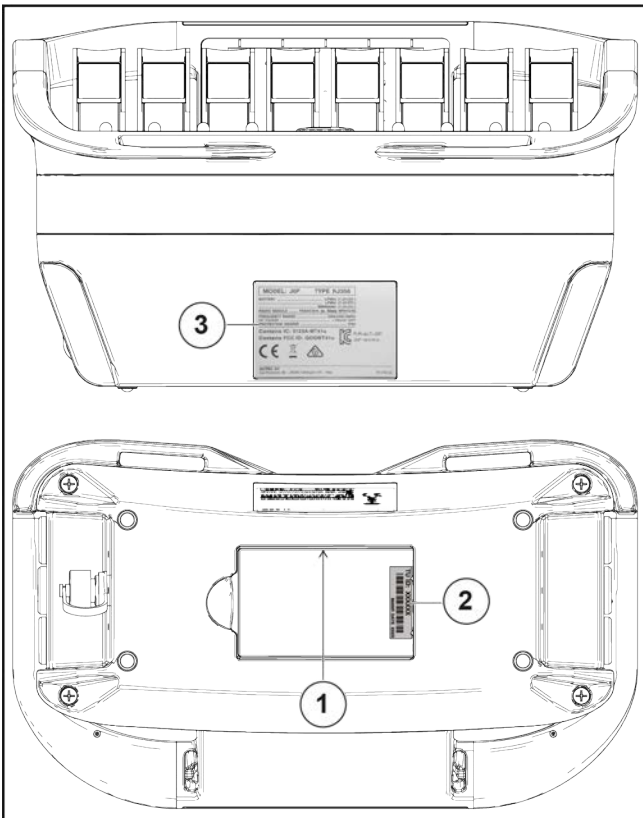

Figure 108: Transmitter unit plates

## Receiver unit plates

There are two plates on the receiver unit:

### 1. Receiver unit identification plate.

Information contained: The serial number (SN) of the radio control, a QR code and the year of manufacture.

### 2. Technical data plate.

Information contained: The Model, the Type and the main technical data of the receiver unit, the marking and any trademarks of the radio control.

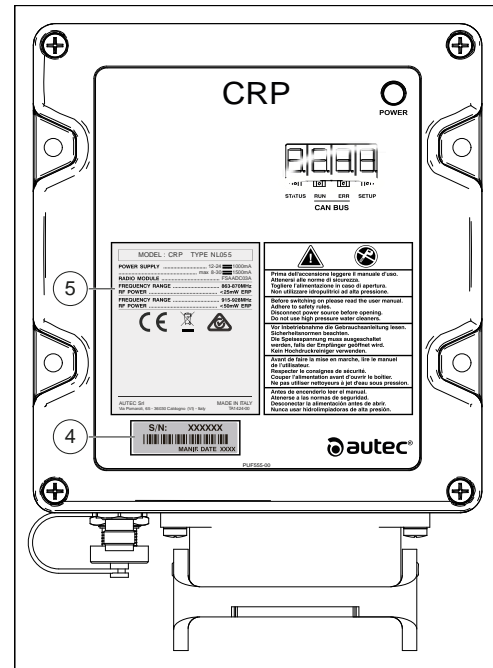

Figure 109: Receiver unit plates

## Transmitter unit push-button panel

1. Button to confirm the recognition of the attachment on the display.
2. Engine and horn start consent.  
Sound the horn when the radio control is started.
3. M-KEY: The M-Key allows for powering the transmitter unit.  
Push the M-Key all the way into its housing.
4. Emergency electric pump button for platform rescue:
  - To retract the telescopic boom: keep the button pressed to activate the rescue pump.
  - Perform only the maneuvers strictly necessary to return to the ground.
5. Engine start button:
  - Before switching on, the red EMERGENCY STOP button must be turned off.
  - Press the button (2) then press the button (5) to start the engine.
6. Wired control connector.  
Maneuvering consent from the platform.
7. Scroll display pages.
8. Display illumination.
9. Not used.
10. Telescopic boom lights switch.
11. Attachment display and scroll page.
12. 2.8" color display that displays machine work and stability information, engine warnings, attachment in use.

13. Right joystick:

- Boom lifting / lowering.
- Forward / backward tilting of the load (selected TILT).
- AUX attachment control (selected AUX).

14. Left joystick:

- Telescopic boom extension / retraction.
- Turret rotation.

15. Attachment motion selector.

16. Attachment motion selector - 12V in the boom head.

17. Attachment motion selector.

18. Load tilt or platform leveling consent.

19. "EMERGENCY STOP" red button.

If pressed, it allows you to stop the heat engine. In case of danger, it allows the user to stop hydraulic movements.

To resume hydraulic movements, turn the red button clockwise.

20. Engine speed management switch (RPM).

21. Speed selector for hydraulic movements.

22. AUX (attachment) or TILT (load / basket tilt) movement selector switch.

23. Multiple movements of the attachment: "I / II" and "Hydraulic attachment blocking".



Figure 110: Transmitter unit push-button panel

## 2.8. OPTIONAL

### 2.8.1 AIR CONDITIONING



The air conditioning works only when the telehandler motor is running. When the air conditioner is on, always work with the cabin closed. During the winter: ensure correct operation and the effectiveness of the air conditioning system. Activate the compressor once a week, even if for a short time, to ensure the lubrication of the internal seals. In cold climates: warm up the engine before starting the compressor to allow the liquid refrigerant, accumulated in the lower part of the compressor circuit, to turn into gas thanks to the action of the heat emitted by the engine. Liquid refrigerant can damage the compressor. Do not try to repair any faults. If the air conditioner is not working properly, contact an authorized dealer.

The specific controls of the Air Conditioning system are available on the HEATING and AIR CONDITIONING page together with the ventilation and heating controls.

To access the HEATING and AIR CONDITIONING

page, briefly press the touch button  on the button bar, at the bottom of the HMI Display.

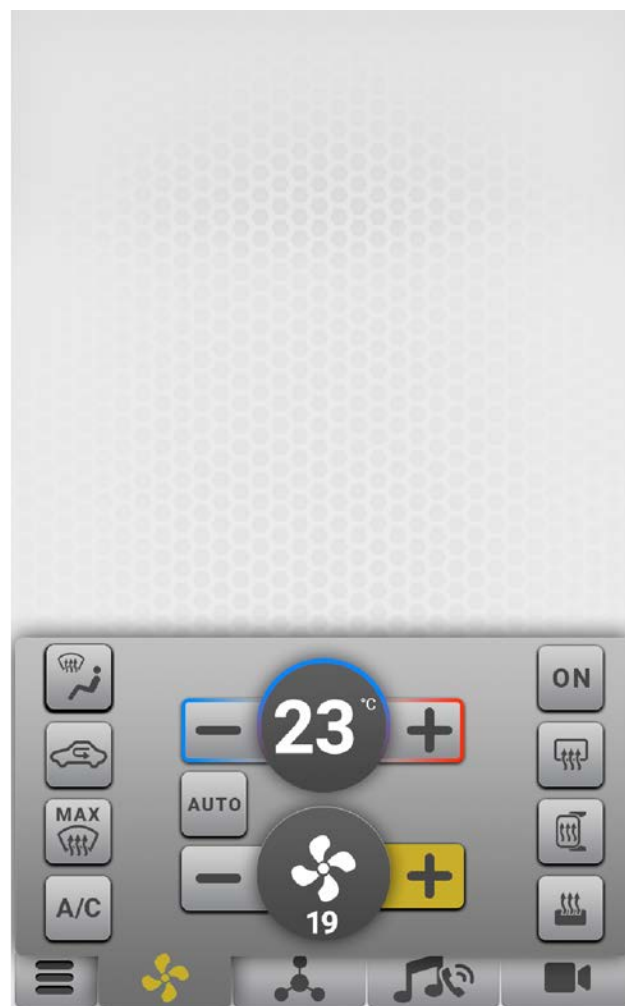





Figure 111: Air conditioning

Table 86. AC specific commands overview:

|   |  |
|---|--|
|  | Max windshield defrost (33° C - 91.4° F and steady speed). |
|  | Air conditioning ON / OFF.                                 |
|  | Automatic control.   |

On the HEATING and AIR CONDITIONING control panel, briefly press the touch buttons to enable or disable all features.

### 2.8.2 BOOM SUSPENSION

The boom suspension allows for absorbing the shocks of the forklift truck on uneven terrain (example: moving straw in a field).

#### Activation

There are two types of activation:

1. AUTO key (1), activation above 5 km / h / 3.1 mph.

2. FORCED key (2), standard activation requested by the operator.

On keys (1) and (2) a LED lights up (1a) and (2a) to indicate that the feature is enabled.

**Operation**

- Rest the forks or attachment on the ground and raise the front wheels just a few centimeters.
- Press key (1) or (2), the LED (1a) or (2a) lights up to indicate that the boom suspension is enabled.
- Press key (1) or (2) again, so that the LED (1a) or (2a) switches off to indicate that the boom suspension is disabled.

 Boom suspension is enabled up to a lifting height of 3 m / 9.8 ft from the pivot axis of the plate to the ground with boom retracted.

Boom suspension is disabled:

- Operating over 3 m / 9.8 ft in height or carrying out another hydraulic movement (tilt, extension, descent, attachment),
- Operating with an articulated platform.

If the boom suspension is temporarily disabled, the LED (1a) or (2a) of the key goes out.

When the heat engine is off, the boom suspension is automatically disabled.

The device operates two pins (X, Y) which move horizontally on the quick coupling, outwards (blocking the attachment) and inwards (unblocking the attachment).

 *To block the attachment, the two blocking pins must protrude completely from the quick coupling holes.*

**Description of controls**

To select the “hydraulic attachment block” device, the operator must keep pressing on the button on the control console (1).

On the button (1) the LED lights up (2) to indicate that the feature is active.

The operator can operate the two pins (X, Y) by holding down the button (1) and pressing the optional control rocker button (4) on the left joystick (3):

- downwards, the two pins come out and block the attachment;
- upwards, the two pins retract and release the attachment.

Releasing the button (1), the operator deactivates the hydraulic attachment blocking device and restores the standard controls of the option.



Figure 112: Boom suspension

**2.8.3 HYDRAULIC BLOCK OF THE ATTACHMENT**

Precautions to be taken if the machine is supplied with “hydraulic block of the attachment” device.

This electrically controlled hydraulic movement device allows you to block or unblock an attachment from the operator's seat.

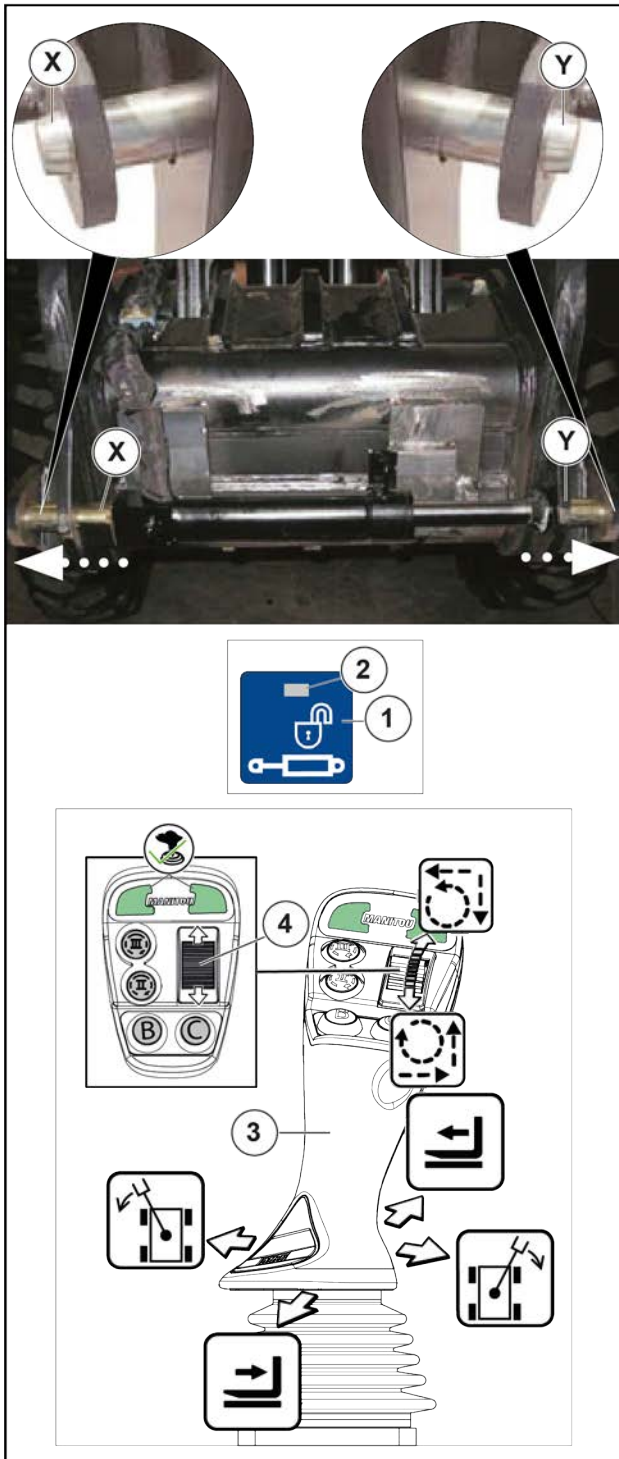

Figure 113: Hydraulic block and description of attachment controls

### 2.8.4 FRONT AND SIDE CAMERA SYSTEM

The machine is equipped with an optional video system which consists of two video cameras (1A-2A) and a 7" LCD monitor (3) inside the cabin.

The two cameras are installed on the machine on the sides:

1. Front (boom head) (1A).

2. Side (engine part, near the rear-view mirrors) (2A).



Figure 114: Front and side camera system

### 2.8.5 RADIO CONTROL FOR ATTACHMENT MOVEMENT AND TELESCOPIC HANDLER MOVEMENT

The Radio Control object is composed of:

1. Transmitter (push button panel).
2. Receiver.



Figure 115: Radio control

3. Battery charger (3) and battery (3a).
4. Transmitter unit support (4) positioned in the cabin, behind the operator's seat.
  - Release the safety block (4b) to raise the boom (4a) that holds the transmitter unit (1) on the support (4).

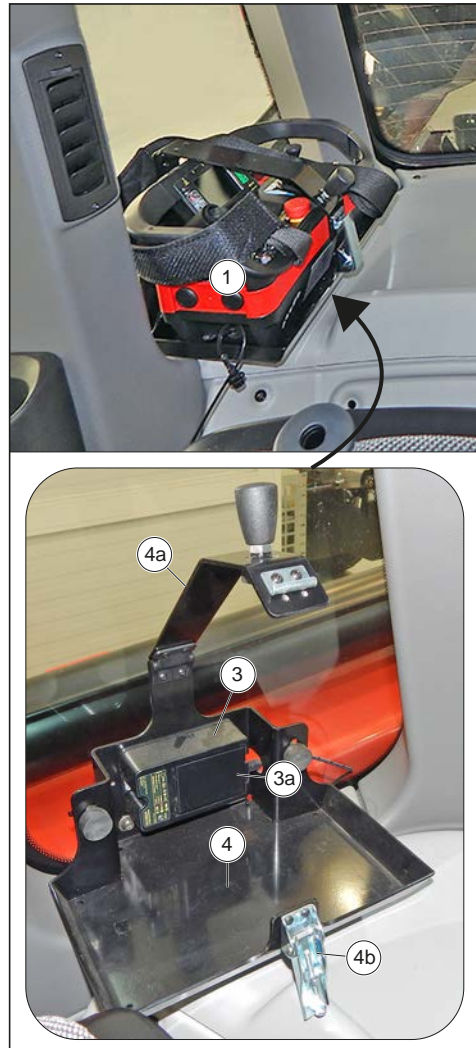

Figure 116: Transmitter unit and support

#### Radio control identification

The serial number (SN) is the only reference that must be used to uniquely identify the radio control both in case of maintenance interventions and in case of declarations to concerned bodies.

The serial number (SN) and other information relating to the radio control are found on some plates both in the transmitter and in the receiver.

These plates must not be:

- Removed from their position (removal entails the immediate forfeiture of the warranty).
- Altered or damaged (contact MANITOU for replacement).

#### Transmitter unit plates

There are three plates in the transmitter unit:

1. Identification plate of the radio control.  
Information contained: the serial number of the radio control (SN), a QR code and the year of manufacture.
2. Transmitter unit identification plate.

Information contained: the year of manufacture, a QR code and the identification number of the transmitter unit (TU ID).

### 3. Technical data plate.

Information contained: The Model, the Type and the main technical data of the transmitter unit, the marking and any trademarks of the radio control.

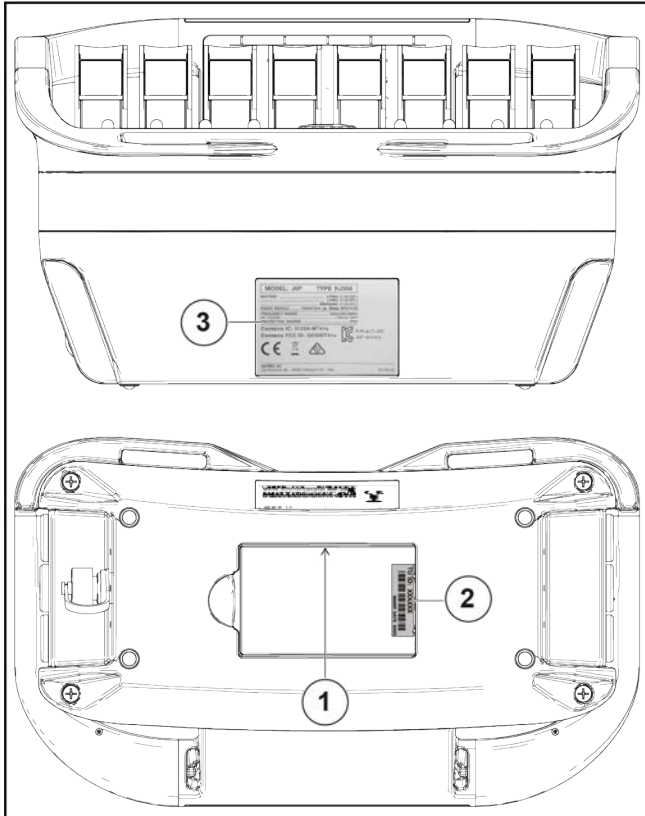

Figure 117: Transmitter unit plates

### Receiver unit plates

There are two plates on the receiver unit:

1. Receiver unit identification plate.  
Information contained: The serial number (SN) of the radio control, a QR code and the year of manufacture.
2. Technical data plate.  
Information contained: The Model, the Type and the main technical data of the receiver unit, the marking and any trademarks of the radio control.

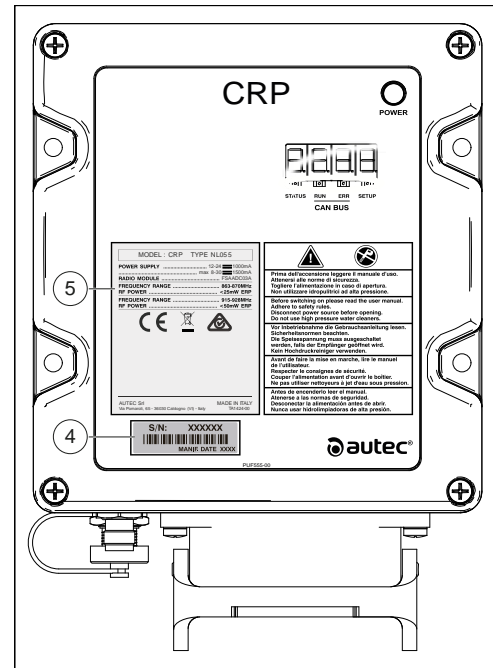

Figure 118: Receiver unit plates

### Transmitter unit push-button panel

1. Button to confirm the recognition of the attachment on the display.
2. Engine and horn start consent.  
Sound the horn when the radio control is started.
3. M-KEY: The M-Key allows for powering the transmitter unit.  
Push the M-Key all the way into its housing.
4. Emergency electric pump button for platform rescue:
  - To retract the telescopic boom: keep the button pressed to activate the rescue pump.
  - Perform only the maneuvers strictly necessary to return to the ground.
5. Engine start button:
  - Before switching on, the red EMERGENCY STOP button must be turned off.
  - Press the button (2) then press the button (5) to start the engine.
6. Wired control connector.  
Maneuvering consent from the platform.
7. Scroll display pages.
8. Display illumination.
9. Not used.
10. Telescopic boom lights switch.
11. Attachment display and scroll page.
12. 4.3 "color display that displays machine work and stability information, engine warnings, attachment in use.

13. Right joystick:

- Boom lifting / lowering.
- Forward / backward tilting of the load (selected TILT).
- AUX attachment control (selected AUX).

14. Left joystick (basket or machine features):

- telescopic boom extension / retraction.
- turret rotation.

15. Stabilizer movements activation switch.

16. Stabilizer movements switch.

17. Steering mode selection switch.

18. Load tilt or platform leveling consent.

19. "EMERGENCY STOP" red button. If pressed, it allows you to stop the heat engine. In case of danger, it allows the user to stop hydraulic

movements. To resume hydraulic movements, turn the red button clockwise.

20. Engine speed management switch (RPM).

21. Speed selector for hydraulic movements.

22. AUX (attachment) or TILT (load / basket tilt) movement selector switch.

23. Multiple movements of the attachment: "I / II" and "Hydraulic attachment blocking".

24. Central joystick (driving features):

- travel forward / reverse direction
- steering left / right

25. Stabilizer selector.

26. Driving function consent button.

27. Automatic leveling button for stabilizers.

28. Programming connector (not used).



Figure 119: Transmitter unit push-button panel

### 2.8.6 PREPARING BI-ENERGY UNIT

Hydraulic couplings (1) and electrical sockets (2) prepared for the installation of the "BI-ENERGY" Electrohydraulic Unit.

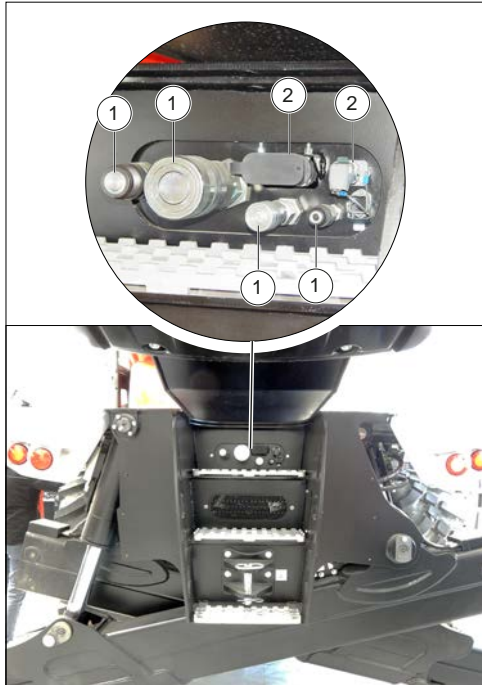

Figure 120: Preparing Bi-Energy unit

## 3. USE OF THE MACHINE

### 3.1. BEFORE USING THE MACHINE

#### 3.1.1 PRE-USE INSPECTION CHECKLIST

#### BEFORE STARTING THE TELESCOPIC HANDLER

- Carry out daily maintenance.
- Make sure the driver's cab is clean, especially the floor and mat.
- Check that no moving objects disturb the control of the telehandler.
- Check whether the lights, headlights and windshield wipers are working properly and their condition.
- Check if the rear view mirrors are in good condition and adjusted properly.
- Check the effectiveness of the acoustic signal.

#### CORRECT POSITION IN THE DRIVER'S SEAT

- No matter how much experience he has, the driver should familiarize himself with the position and use of all control and command tools before putting the telehandler into service.
- Wear clothes suitable for driving the telehandler, avoid fluttering clothes.
- Take protective equipment suitable for the work to be done.
- Prolonged exposure to a loud noise can cause hearing loss. To protect yourself from annoying noises, the use of hearing protection is recommended.
- Always get in and out of the vehicle with access to the driver's cab in front of you and use the handles provided. Do not jump off the telehandler to get off.
- Always be careful when using the telehandler, do not listen to the radio or music with earphones or headphones.
- Never drive with wet or greasy hands or shoes.
- For optimal comfort, adjust the seat to your liking and get in the right position in the driver's cab.

- The driver must always remain in his normal position in the driver's cab: he is forbidden to stretch his arms, legs and in general any part of his body outside the driver's cab of the telehandler.
- Use of the seat belt is mandatory and it must be adjusted to the height of the driver.
- The control elements must never be used improperly (example: as a support to get on or off the telescopic handler, as a clothes hanger, etc.).
- If the control elements are equipped with a forced march device (lever block), it is forbidden to leave the driver's cab without positioning the controls on "neutral".
- It is forbidden to carry passengers in the telehandler or in the driver's cab.

#### VISIBILITY

- The safety of the people in the maneuvering area of the forklift truck, of the forklift truck itself and of the operator, depend on the operator's ability to see the working area of the forklift truck in any circumstance and constantly.
- This forklift truck has been designed to allow the operator to always have good visibility (direct or indirect via rear-view mirrors) of the work area when traveling with the truck unladen and the boom in the transport position.
- If the volume of the load restricts visibility in front, special precautions must be taken:
  - Reverse to destination.
  - Tidy up the site.
  - Help from a someone (positioned outside the forklift truck's range of operation) to direct the maneuver, ensuring that you can always clearly see this person.
- In any case, avoid reversing for too long.
- With some special attachments, it may be necessary to keep the boom in the raised position to move the forklift truck. In this case, the visibility from the right side is limited and special precautions must be taken:
  - Tidy up the site.
  - Help from a someone (positioned outside the forklift truck's range of action) to direct the maneuver.
- Replacement of a hanging load with a pallet load.
- In all cases where the visibility of the route is insufficient, get help from someone (positioned outside the forklift truck's range of operation) to

**⚠ DANGER**

**Under no circumstances should seat adjustments be made while the telehandler is in motion.**

direct the maneuver, making sure that you can always clearly see this person.  
Keep all elements to improve visibility in perfect working order, correctly adjusted and clean: windshields and windows, windshield wipers and washers, headlights and work lights, rear-view mirrors.

### 3.1.2 AREA AROUND THE TELEHANDLER

Carry out a general inspection around the telehandler:

- Leak or stain of liquid on the ground.
- Presence of foreign objects on the telehandler and in the cabin.
- Fixing and locking of the attachment.
- Fixing and adjusting the rear view mirrors.
- Tire condition to identify cuts, bumps, wear, etc.



Observe the instructions for the operator.

#### Forklift Cleaning

- Cleaning of the headlights and rear view mirrors.
- Excess dirt or accumulation of material (e.g. straw, flour, sawdust, organic waste, etc.).
- Every day and according to the conditions of use and the environment, the operator must ensure that the forklift is clean.
- The accumulation of flammable materials (e.g. straw, flour, sawdust, organic waste, etc.) and fuel or lubricant leaks must require special attention, as they greatly increase the risk of fire.
- A regular inspection of the entire telehandler, especially the engine compartment and the central part of the chassis, is necessary to establish the frequency of cleaning, in order to avoid potential accumulation or loss of material.

### 3.1.3 FILLING THE FUEL TANK

- Keep the fuel tank as full as possible to minimize condensation due to atmospheric conditions.

**⚠ DANGER**

**Danger of fire.**

**Never fill up with the engine running.**

Do not smoke or approach with an open flame during filling operations or when the tank is open.

- If necessary, add diesel fuel.

- Remove the cap (1).
- Fill the tank with clean and filtered diesel fuel through the filling orifice.
- Put the cap back on.
- Look to make sure that there are no leaks on the tank or pipes.



A lockable tank cap is available as an option



Figure 121: Filling the fuel tank

### 3.1.4 FILLING THE "DEF" TANK

(diesel exhaust fluid (adblue)).

**⚠ WARNING**

#### Danger of corrosive substances

The diesel exhaust fluid (adblue) is a corrosive product.

Protect the bodywork and wear personal protective equipment (gloves and goggles). The level of the diesel exhaust fluid (adblue) is important, an operation with the tank empty or with little fluid can compromise the performance of the three-phase motor.

If necessary, add diesel exhaust fluid (adblue).

- Remove the cap (1).
- Slowly fill the tank to the bottom of the fill chute.
- Always maintain a good level to limit the alteration of the product.
- Put the cap back on.



Figure 122: Filling the "DEF" tank



A lockable tank cap is available as an option

**"DEF" (diesel exhaust fluid (adblue)) quality**

The quality of the diesel exhaust fluid (adblue) can be measured with the aid of a refractometer; the diesel exhaust fluid (adblue) must comply with ISO 22241-1 with 32.5% urea solution. Refractometer (MANITOU reference: 959709)

**"DEF" (diesel exhaust fluid (adblue)) storage**

Up to 4 months of non-use of the forklift: check the quality of the diesel exhaust fluid (adblue) with the aid of a refractometer.  
Beyond 4 months: change the diesel exhaust fluid (adblue). Empty and rinse the tank.

**3.1.5 WORK AREA INSPECTION**

- Follow the site's safety rules.
- During handling operations, make sure that nothing or no one obstructs the maneuvering of the carriage and the load.
- Do not authorize anyone to approach the maneuvering area of the telehandler or to pass under the load.

Driving on a longitudinal slope:

- Advance and brake smoothly.
- Movement when unladen: forks or attachment facing downhill.

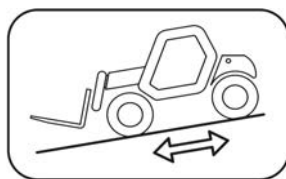

- Movement with load: forks or attachment facing uphill.

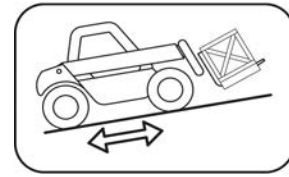

Consider the dimensions of the forklift and the load before engaging a narrow or low passage.

Never engage a loading gangway without having checked:

- That it is correctly positioned and locked.
- That the element to which it is connected (wagon, truck, etc.) cannot move.
- That it is foreseen for the total weight of the laden forklift truck.
- That the gangway is designed for the overall dimensions of the forklift.
- Never use a gangway, a platform or a freight elevator without being sure that they are correctly foreseen for the weight and dimensions of the laden forklift, and without having checked that they are in good condition.
- Pay the utmost attention to: loading docks, excavations, scaffolding, unstable ground, wells.
- Check the stability and hardness of the ground under the wheels and/or stabilizers before lifting the load or extending the boom with the load. If necessary, add a suitable wedge under the stabilizers.
- Verify that the scaffolding, loading platform, stack or ground can support the load.
- Never stack loads on uneven ground as they may tip over.



**Resting hazard**

There is a risk of support if the load or the attachment remains on a structure for a long time due to the descent of the boom when the oil in the jacks cools.

Regularly check the distance between the load or attachment and the structure, readjust if necessary.

If possible, use the forklift with an oil temperature as close as possible to ambient temperature.

When working near overhead power lines, check that the safety distance between the forklift's working area and the power line is sufficient.

**⚠ DANGER****Electrocution hazard**

There is a risk of electrocution or serious accident when working or parking the forklift too close to electrical wiring.

You need to inquire with your local electricity supply company.

In case of strong wind, do not proceed with handling: risk of compromising the stability of the forklift and the load, especially if this is exposed to strong wind.

Prevent the risk of fire associated with use in a dusty and flammable atmosphere (e.g. straw, flour, sawdust, organic waste, etc.).

**3.2. ENTER THE CABIN****3.2.1 GETTING IN AND OUT OF THE VEHICLE****⚠ WARNING**

The vehicle is equipped with three ladders (front, rear and right side) that allow access to the walkable surface above the vehicle's undercarriage. The ladders must only be used during maintenance operations and only to access the walkable surface.

It is not allowed to use the front, rear or right side ladder to get inside the vehicle cabin.

**⚠ WARNING**

To get in and out of the vehicle, use the access ladder located on the right side of the vehicle (fuel tank area).

The telehandler is equipped with access steps (1) and two handles (2) which are located inside the cabin to facilitate the operator's entry and exit from it.

Always get on and off with your face facing the telehandler.

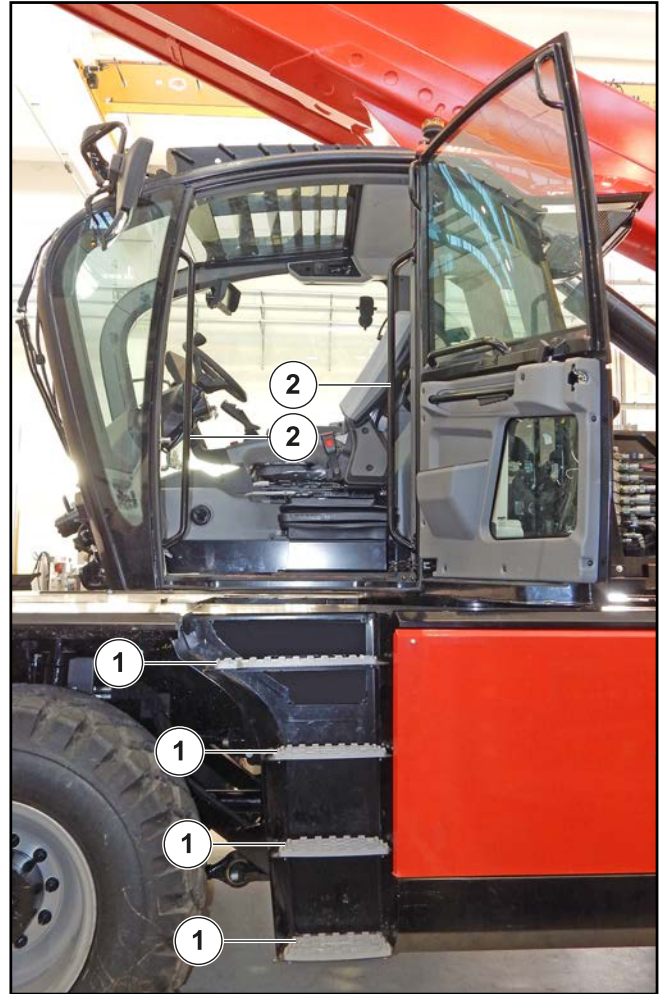

Figure 123: Getting in and out of the vehicle

**⚠ WARNING**

To climb up it is necessary to use the steps and the specially installed handles.

A bad grip, a badly positioned foot, could involve the risk of falling, therefore: do not cling to the steering wheel or other controls.

## 3.3. TURNING THE MACHINE ON AND OFF

### 3.3.1 STARTING THE MACHINE

#### Starting the forklift truck

##### Safety rules

The forklift truck can only be started or maneuvered when the driver is in the driver's cab, with the seat belt fastened and adjusted.

- Do not tow or push the forklift truck to start it.

**⚠ DANGER**

##### Risk of serious transmission damage

This maneuver could cause serious damage to the transmission.

Put the gear in neutral position if you need to tow the forklift truck.

##### Recommendations

- Make sure that the gear lever is in neutral.
- Turn the ignition key to position I to allow electrical contact.
- Check the fuel level on the gauge.
- Turn the ignition key to position II to allow preheating and wait 15 seconds. (If required by environmental conditions).
- Do not activate the starter for more than 15 seconds, and allow it to preheat for 10 seconds between all attempts.
- Press the accelerator and turn the ignition key fully, the engine should start. Release the ignition key and let the engine run at low speed.
- Before operating in very cold climatic conditions, wait for the heat engine and hydraulic systems to warm up properly.
- Look at all control instruments immediately after starting, with the engine warm, and at regular

intervals during use, in order to quickly identify and resolve any faults.

- If any of the instruments indicates a fault, stop the engine and carry out the necessary operations right away.

### 3.3.2 TURNING OFF THE MACHINE

#### Stopping the forklift truck

##### Safety rules

- Before stopping the forklift truck after intensive work, let the heat engine idle for a few moments to allow the coolant and oil to lower the engine and transmission temperatures.

This precaution must be strictly observed in the case of frequent stops of the heat engine; otherwise the temperature of some parts would increase considerably.

- Never leave the ignition key in the forklift truck without the driver.
- When the forklift truck has stopped, rest the forks or attachment on the ground, place the shift lever in neutral, apply the parking brake and place the gear lever in neutral.
- If the driver has to leave the driver's cab, even temporarily, apply the parking brake and put the gear lever in neutral.
- Make sure the forklift truck is parked in such a way as not to hinder traffic and at least one meter away from railroad tracks.
- In case of prolonged parking, protect the forklift truck from the weather, particularly in the event of frost (Check the antifreeze level), close the rear window, lock the cabin door and the engine hood.

##### Recommendations for stopping

- Park the forklift truck on level ground or with a gradient of less than 15%.
- Place the gear lever in neutral.
- Apply the parking brake.
- Fully retract the boom.
- Rest the forks or attachment flat on the ground.
- Switch off the three-phase motor.
- Remove the ignition key.
- Check that the door is locked and that the rear window and engine cover are also closed.

Before leaving the driver's cab, make sure you have carried out all the forklift truck stopping operations correctly, to ensure your safety and the safety of others.

## 3.4. USE OF ATTACHMENTS

### 3.4.1 SAFETY RECOMMENDATIONS FOR ATTACHMENTS

#### INTRODUCTION

The manufacturer offers you a wide range of attachments (with warranty) for your telehandler that are perfectly adapted to it.

The attachments are delivered with a load chart for your telehandler. The recommendations booklet and the load chart must remain inside the telehandler. The use of attachments is described in the recommendations contained in this manual.

Some specific uses require the adaptation of an attachment not included in the options on the price list.

There are other solutions. For more information, contact your agent or dealer.



*Only approved attachments and "CE" certified attachments by the manufacturer can be used on our telehandlers. The manufacturer shall not be held liable in the event of alteration or use of attachments without his knowledge.*



*MANITOU has ensured that this forklift truck can be used under normal conditions of use as specified in the instruction manual, with a static test coefficient of 1.33 and a dynamic test coefficient of 1, provided for in the harmonized standards EN 1459 for forklift trucks with variable capacity and EN 1726-1 for masted forklift trucks.*

The use of interchangeable attachments not originally provided on the machine is prohibited. In the event of subsequent requests for implementation of machine features with other attachments, before commissioning, the user is obliged to ask an authorized MANITOU technician to perform a suitability check, who will verify the correct functioning and update the documentation necessary for use of the new attachment. Only after this check will a new "CE" certificate of conformity of the machine be issued, showing only the new attachments installed.

#### GENERAL ADVICE REGARDING USE OF THE FORKLIFT TRUCK

#### **⚠ DANGER**

Observe the data indicated on the load charts. In no case should you try to lift loads heavier than those allowed on the load charts attached to the machine.

#### **⚠ DANGER**

Carry the load in a low position and with the telescopic boom fully retracted.

#### **⚠ DANGER**

Drive the truck at a speed appropriate to the conditions of the terrain.

#### **⚠ DANGER**

When the forklift truck is unladen, travel with the telescopic boom lowered and fully retracted.

#### **⚠ DANGER**

Never go too fast or brake suddenly with a load.

#### **⚠ DANGER**

When the load is lifted, make sure that no one can interfere with operation and do not perform incorrect maneuvers.

#### **⚠ DANGER**

Do not attempt to perform operations that exceed the capabilities of the telehandler.

#### **⚠ DANGER**

Pay attention to electrical cables.

**⚠ DANGER**

Never leave the truck parked with a raised load.

**⚠ DANGER**

Do not authorize anyone to approach or pass under the load.

**⚠ DANGER**

Always think about safety and only carry well-balanced loads.

**⚠ DANGER**

Do not leave the truck loaded on an incline greater than 15% with the parking brake applied.

**⚠ DANGER**

The following attachments are not intended for systems for lifting or moving people.

**⚠ DANGER**

Remember to request a check-up every year from the USL in your area (only for Italy).

**⚠ DANGER**

It is forbidden to lift suspended loads with the fork attachment or other support not provided for this feature. Contact an authorized dealer, see crane attachments list.

**⚠ DANGER**

Non-conforming calibration of the safety system can be very dangerous. If in any doubt, contact an authorized dealer immediately.

**⚠ DANGER****Risk of damage to the vehicle**

Some attachments, taking into account their size, and with the boom lowered and retracted, risk interfering with the front tires and causing them to deteriorate if the equipment is tilted down.

To eliminate this risk, extend the telescopic boom long enough for the telescopic handler and attachment so that no interference occurs.

**⚠ DANGER**

The maximum loads are defined by the capacity of the telehandler, taking into account the weight and the center of gravity of the attachment. If the attachment has a lower capacity than the telehandler, never exceed this limit.

Before putting any type of attachment on the telehandler into service, make sure that the machine is compatible and that the safety system is calibrated for the attachment used.

**3.4.2 COUPLING MANEUVER FOR ATTACHMENTS****Fitting attachment**

- Make sure the attachment is in a position that makes it easy to hook the quick coupler. In case it is pointing in the wrong direction, take the necessary precautions to move it in extremely safe conditions.
- Check that the blocking pin is inserted into the holder on the chassis.
- Position the telehandler with the boom lowered, facing front and parallel to the attachment and tilt the quick coupler forward (1).
- Bring the quick coupler under the connecting pipe of the attachment, raise the boom slightly and tilt the coupler backwards to position the attachment (2).
- Take the attachment off the ground to facilitate blocking (3).

**If the attachment is equipped with a hydraulic circuit**

*Carefully clean the quick couplings and protect unused orifices with the plugs provided for this purpose.*

- After blocking the attachment (see Manual block or Hydraulic block of the attachment) it is necessary to:
  - Switch off the heat engine and maintain electrical contact on the telehandler.

- Relieve the pressure of the attachment's hydraulic circuit by pressing the optional control button on the joystick 4 or 5 times.
- Connect the quick couplings, respecting the logic of the hydraulic movements of the attachment.

### REFIT OF THE ATTACHMENT WITH MANUAL BLOCK

#### Manual blocking

Take the blocking pin (4) on the support and insert it into the hole in the quick coupling (4a) to block the attachment (3).

Do not forget to put in the split pin (5).

#### Manual release

Proceed in the reverse order to that of MANUAL BLOCKING and make sure you put the blocking pin back into the support on the chassis.

#### Removal (and installation) of the attachment

Proceed in the reverse order to that of FITTING ATTACHMENT, making sure you place it in a safe position on compact and flat ground. If the attachment is equipped with a hydraulic system, connect the quick couplings or, vice versa, disconnect them in case of attachment disassembly after decompressing the circuit.



*Keep the quick couplings clean and protect unused orifices with the caps provided.*

### REFIT OF THE ATTACHMENT WITH HYDRAULIC BLOCK (optional)

#### Fitting attachment

- Make sure the attachment is in a position that makes it easy to hook the quick coupler. In case it is pointing in the wrong direction, take the necessary precautions to move it in extremely safe conditions.
- Check that the blocking pin is inserted into the holder on the chassis.
- Position the telehandler with the boom lowered, facing front and parallel to the attachment and tilt the quick coupler forward (1).
- Bring the quick coupler under the connecting pipe of the attachment, raise the boom slightly and tilt the coupler backwards to position the attachment (2).
- Take the attachment off the ground to facilitate blocking (3).
- Activate the optional control to block the attachment (see next chapter).

#### Hydraulic blocking and unblocking (optional)

The blocking and unblocking of any attachment takes place by means of two pins which protrude from the holes of the quick coupling (4).

#### Removal (and installation) of the attachment

Proceed in the reverse order to that of FITTING ATTACHMENT, making sure you place it in a safe position on compact and flat ground.

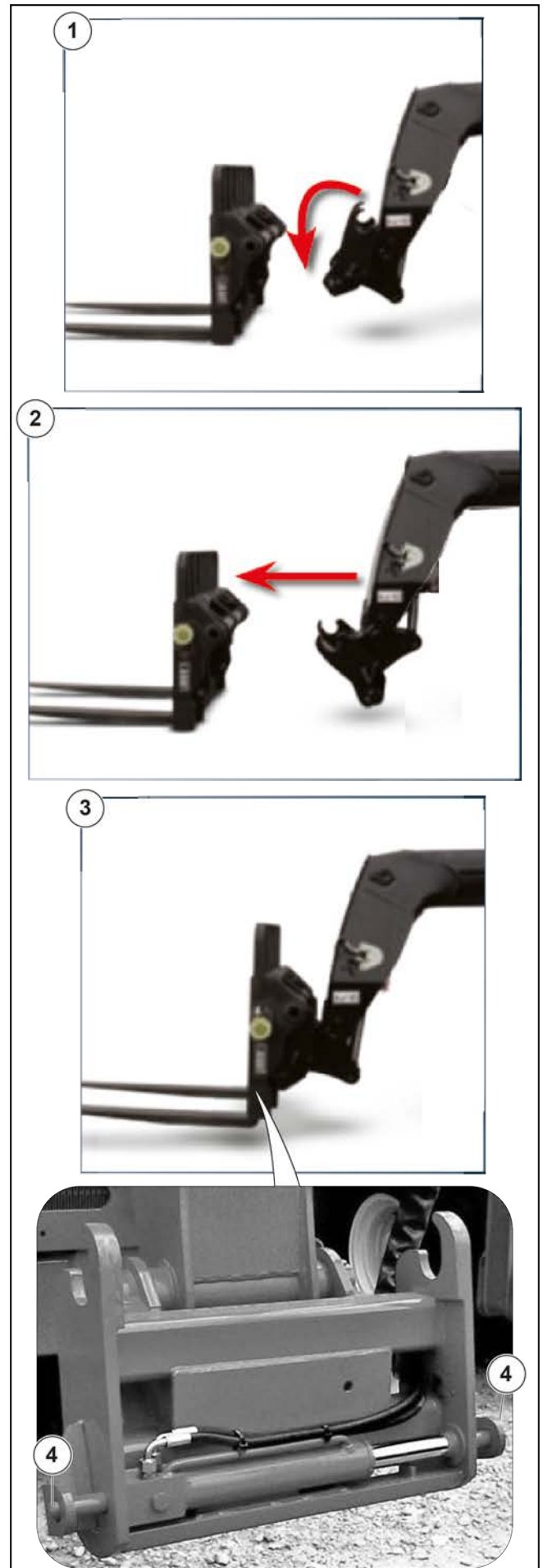

Figure 124: Refit of the attachment with hydraulic block (optional)

### 3.4.3 AUTOMATIC RECOGNITION OF THE "E-RECO" ATTACHMENT

The machine is equipped with an electronic recognition system that identifies the type of attachment installed at the time of coupling.

This system facilitates and speeds up attachment changing operations.

The system features two devices: one located on the telescopic boom and one on the attachment.

**Automatic mode:** after identification of the type of attachment and the operator's confirmation, the recognition system sets the machine to operate with the connected attachment.

**Manual mode:** the machine can operate with an attachment without an identification device and in this case it is the operator's responsibility to identify and confirm the type of attachment connected.

- Asks the Operator to confirm that the recognized attachment is the one actually connected to the machine.
- To confirm the type of attachment, press the knob selector (2).

#### Manual mode

Straight after connecting an attachment without the identification device, the recognition system:

- Does not recognize the connected attachment.
- The operator must select the type of attachment connected to the machine.

The operator must manually select the type of attachment installed, as follows:

- Press the key (3) to exit the "empty" mode (1) (no attachment connected).
- Turn the knob (2) to select the attachment that is connected.
- To confirm the type of attachment, press the knob selector (2).



*In "empty" mode the machine can move the boom but with maximum lifting capacity set at 500 kg (1102 lb).*



Figure 125: Selection and confirmation of attachment

#### Automatic mode

Straight after connecting an attachment, the recognition system:

- Identifies the type of attachment (1).

## ⚠ WARNING

#### Risk of injury to people or damage to the forklift truck

Not following recommendations could cause malfunctions of your forklift truck and property damage and injuries to anyone close to the working area of the machine.

In both modes: it is the operator's responsibility to make sure that the attachment connected and shown on the display is the one identified by the recognition system or selected manually.

*Rispettare le procedure sopra descritte.*



Figure 126: "E-RECO" attachment recognition

### 3.4.4 FLOW LIMITER OF THE ATTACHMENT CIRCUIT

#### **⚠ DANGER**

This option must be used only with an attachment requiring continuous hydraulic movement such as: sweeper, distribution bucket, mixer, sprayer, etc. Therefore it is strictly forbidden during handling and in all other cases (winch, boom, winch boom, hook, etc.).

#### Continuous hydraulic movement of the attachment

On the display, on the "DRIVE page", check that the oil flow percentage bar is on 0%.

Move the button (1) that controls the attachment backward and forward (according to the type of attachment), press the key (2) and release the button (1). The flashing light (1a) indicates its use.

On the display, "DRIVE page", at the bottom, the bar that regulates the oil flow (3) is activated by means of the "+ / -" keys as needed from 0% to 100%.

Stopping the continuous hydraulic movement of the attachment depends on:

- Adjusting the bar that adjusts the oil flow to 0%.
- Moving the button (1) that controls the attachment backward or forward.
- Press the key (2). The warning light (1a) is off.
- Or setting the potentiometer bar to 0%.
- Operator not seated.
- Exclusion of attachment movement control button (1) from key / navigator.
- Enabling and disabling control of 2nd hydraulic line on boom.
- Hydraulic block of the active attachment.
- Telescopic handler in alarm.

Before starting the telehandler check that the potentiometer bar is at 0%.



*If the operator moves away from the driver's cab, continuous hydraulic movement is automatically stopped and must be restarted.*



Figure 127: Continuous hydraulic movement of the attachment

## 3.5. DRIVING THE MACHINE

### 3.5.1 USING STEERING MODES

The vehicle is equipped with the following steering modes:

- Front wheel drive (driving on road) (1).
- Front and rear wheel drive in the same direction (lateral movement) (2).
- Opposite direction front and rear wheel drive (small turning radius) (3).
- Front wheel drive and rear wheel drive angle block (4).



*When the steering mode is enabled, the warning light (5) is steady and the selected driving indicator is shown on the display.*



*Changing the steering mode is no longer possible when the speed exceeds 11 km / h.*



Figure 128: Steering mode

## CHANGING STEERING MODE

**⚠ DANGER**

Check the front and rear wheel alignment each time the telehandler is started.

The wheels must be aligned and the forklift truck must be in front-wheel driving mode during use on public roads.

1. Align the front and rear wheels.
2. Press the key (1, 2, 3, 4) to select the desired direction mode, the flashing warning light (5) confirms the request.



Figure 129: Steering mode

When the steering mode is enabled, the warning light (5) is steady and the selected driving indicator is shown on the display.

### 3.5.2 USING THE SEMI-AUTOMATIC WHEEL ALIGNMENT

#### FRONT AND REAR WHEEL ALIGNMENT INDICATOR



Green indicator on: indicates the alignment of the front wheels with respect to the axis of the telehandler.

Yellow indicator on: indicates the alignment of the rear wheels with respect to the axis of the telehandler.

Front and rear wheel alignment procedure

1. Select the steering mode "opposite direction front and rear wheel drive (small turning radius)".
2. Turn the steering wheel so that the yellow rear wheels alignment light comes on.
3. Select the steering mode "Front-wheel drive (driving on road)".
4. Turn the steering wheel so that the green front wheels alignment light comes on.

Once the front and rear wheels are aligned, one of the steering modes can be selected.

With use, the wheels may become uncoordinated, at least every 20 hours of operation the realignment of the wheels must be carried out.

### 3.5.3 USING THE PARKING BRAKE

The telehandler has the option of having automatic or manual application of the parking brake, which can be selected from keys in the cabin.

The parking brake acts on the front and rear axles.

- To activate the manual parking brake, press the key (1). A red warning light is lit on the display.
- To activate the automatic parking brake, press the button (2). A red warning light is lit on the display.

When the parking brake is applied, the brake lights come on for 2 minutes.

To release the parking brake, press key (1) or (2). The red light on the display will go out.

When starting the telehandler, the parking brake is engaged.

For the safety of the machine and the driver, the parking brake is applied automatically under certain conditions.

With the direction selector in the "neutral" position, the parking brake remains applied despite the pressure on the accelerator pedal.

With direction selected and by accelerating, the brake will be released and the vehicle will move.

The conditions for applying the safety brake are:

- The gearbox remains in the neutral position for several seconds.
- The traveling speed of the telehandler is less than 3.6 km / h (2.23 mph) or the machine has stopped.

The automatic emergency brake is disabled when the direction selector is enabled and the engine speed is increased by pressing the accelerator pedal.



Figure 130: Using the parking brake

### 3.5.4 DRIVING MODES

The telehandler equipped with electronically controlled transmission allows the operator to choose from three different driving modes:

1. Drive (for road use).
2. Handling (for work use).
3. Eco (to reduce consumption).

The operator selects the mode based on the driving feeling he wants to achieve with the telehandler and according to the different operating needs.

When the telehandler is switched on, the "Drive" mode is active by default.

#### 1. "Drive" mode:

It allows the operator a dynamic and rapid drive; it is ideal for all uses where speed is crucial. In fact, you have the maximum driving speed: - in low gear: 0 - 14 km / h (0 - 8.6 mph) - in high gear: 0 - 40 km / h (0 - 24.8 mph). Mode can be activated in low and high gear.

#### 2. "Handling" mode:

It allows the operator to have maximum progressivity and torque performance for all heavy handling and loading tasks.

When the operator makes the telehandler go forward or reverses it and moves the joysticks to control the hydraulic movements, the engine revolutions automatically increase up to maximum speed (if necessary), but the traveling speed does not change and always requires pedal action on the accelerator. While with the telehandler parked "on tires" or on "stabilizers" the operator can increase (+) or decrease (-) the engine revolutions (rpm) on the display (2A). The set value will be the minimum number of engine revolutions below which it is not possible to go. The number of engine revolutions will only increase during hydraulic movements.

The maximum traveling speed of the telehandler is limited:

- In low gear: 0 - 14 km / h (0 - 8.6 mph).
- In high gear: 0 - 25 km / h (0 - 15.5 mph).

Mode can be activated in low and high gear.

#### 3. ECO mode:

This feature adjusts the transmission to maintain the maximum traveling speed of the telehandler at a lower engine RPM, thus saving fuel.

- In low gear: 0 - 14 km / h (0 - 8.6 mph).
- In high gear: 0 - 40 km / h (0 - 24.8 mph).

When the speed is reached (with the accelerator pedal), if maintained for a short period of time, the ECO feature is activated.

Mode can be activated in low and high gear.



Figure 131: Driving modes

### 3.5.5 USING THE FORWARD / NEUTRAL / REVERSE DIRECTION SELECTOR (FNR)

To move the telehandler forward or to reverse, press the “FNR” selector located on the right joystick of the operator's seat.

FORWARD GEAR (F): push the selector (1) forward

REVERSE (R): push the selector (1) back.

- The rear video camera will be activated automatically and the pre-defined screen with video recording on the display in the cabin turn on.

IN NEUTRAL (N): to start the telehandler, the selector (1) must be in the neutral position (N). The selected direction is shown on the display on the “DRIVE” page.

Getting the telehandler to go in the opposite direction must be done at low speed and without accelerating.

#### Getting the telehandler to go forward or to reverse

To allow and enable movement of the machine, the operator must:

- Close the cabin door.
- Fasten the seat belt (in this condition it is possible to move even with the door open).
- Be seated in the driver's cab.
- Select low or high gear.
- Release the parking brake.
- Check that the machine is positioned on tires:
  - With front turret (no more than +/- 5° of rotation).
  - With turret rotated over +/- 5° and the telescopic boom raised to less than 3 m. An alarm sounds and control panel lights in the cabin turn on to warn you that the turret is not in the front position and the boom is too high.
- Check that the stabilizer beams are:

- Lifted off the ground.
- Completely closed.
- Not fully closed (even just one beam more than 1% open) with an alert for the operator: an alarm sounds and a warning (beams not closed) on the control panel in the cab comes on.
- The stabilizers can be lowered while the machine is in motion. If even one stabilizer is resting on the ground, the movement of the telehandler is disabled. If the stabilizing beams are not fully closed, a warning that beams are not closed sounds and lights up on the control panel in the cabin.



Figure 132: Using the FNR selector

### 3.5.6 TRAVEL SAFETY SYSTEM RESET BUTTON

The telehandler does not travel in some conditions:

- With forward or reverse selector engaged (F / R) and stabilizers resting on the ground (even just 1).
- With turret rotated more than +/- 5° and the telescopic boom raised to a height of more than 3 m / 9.8 ft off the ground.
- With turret rotated more than +/- 5° and the telescopic boom not fully retracted.

Only in exceptional cases and for safety reasons it is possible to move by pressing the travel safety system reset button (1).

- To allow the movement, the operator must briefly press the key (1), a LED (2) on key and a red icon on the display light up to indicate that the feature is enabled.

- To reset the travel safety system, press the button (1) again so that the LED (2) on the key and the icon on the display go out.

## ⚠ DANGER

### Risk of injury to the operator or damage to the telehandler

In order not to compromise the stability of the telehandler, move slowly for short distances on flat and level ground.



Figure 133: Travel safety system reset button

To obtain a precise horizontal position of the telescopic handler, refer to the spirit level (2) on the display on the "STABILITY" page:

- Red bubble machine level (2b).
- Red bubble machine not level (2a).

### How to use this device

Level the telehandler before lifting and extending the boom referring to the appropriate spirit level shown in the lower display area on the "STABILITY" page.

If you notice that the telehandler is not level, lower the telescopic boom and repeat the leveling operation.

### Conditions for operation

The leveling operation is possible if the operator:

- Grabs the lever of the right joystick to enable movement consent (green LEDs on the joystick).
- Is seated in the driver's cab.
- Fastens his seat belt and closes or opens the cabin door.
- Raises the telescopic boom no more than 30° or less than or between 3m / 9.8ft off the ground.
- Maintains a turret rotation angle of less than or between +/- 15°.
- Does not stabilize and rests the stabilizing feet on the ground.

In these conditions, press the buttons (X or Y) to level the telehandler.

## 3.6. STABILITY OF THE MACHINE

### 3.6.1 LEVELING PROCEDURE (ON TIRES)

The telescopic handler is equipped with a device for leveling the chassis with respect to the ground to be able to level the machine and therefore raise the telescopic boom to the maximum height in complete safety and stability.

Depending on the telehandler model, the machine can be tilted sideways (X) or lengthwise (Y).

To control the leveling, keep the buttons (X or / and Y) on the right joystick (1) in the cabin pressed as required:

- Tilting to the left (X1).
- Tilting to the right (X2).
- Tilting forward (Y1).
- Tilting backward (Y2).



*It is possible to level the machine and move the telescopic boom simultaneously.*

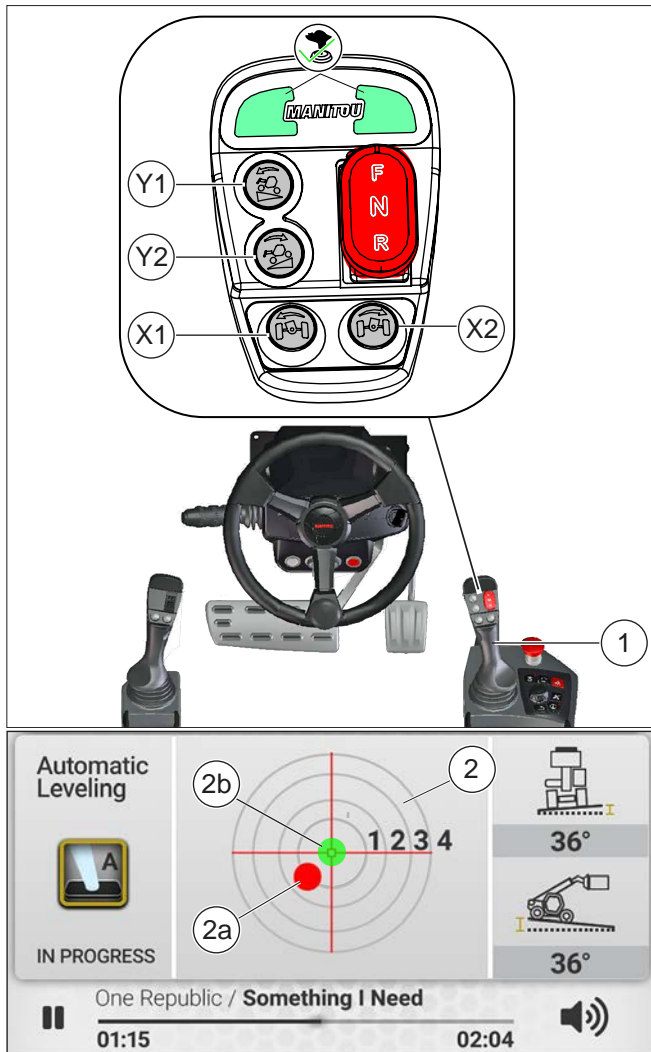

Figure 134: Leveling procedure (on tires)

### 3.6.2 BLOCKING REAR AXLE SWING

The telehandler is equipped with an automatic rear axle swing block device, on wheels, to work with maximum safety and maintain optimal capacity.

Depending on the model of the telescopic handler, the operation of the rear axle is connected to the logic of the rear suspension rams or without suspensions, it is connected to two additional solenoid valves that manage the blocking / unblocking of the rear axle.

To activate the unblocking of the rear axle you must be in the following conditions:

- Turret rotated with an angle of no more than +/- 15°.
- Telescopic boom raised to no more than 55°.
- Red emergency mushroom button not pressed.
- Telescopic handler with less than 4 stabilizing feet resting on the ground.

When the rear deck swing block feature is enabled, an

amber indicator  will light up in the upper display area.

### 3.6.3 STABILIZER MOVEMENTS

- Manual stabilization.
- Automatic stabilization.
- Self-leveling of stabilizers.

### 3.6.4 MANUAL STABILIZATION PROCEDURE

Once the telescopic handler has been positioned in the work area and the stabilizers have been selected with the keys (1, 2, 3, 4) on the right armrest or by touch on the display on the "STABILITY" page, move the small joystick (J) that controls the extension, the retraction and the lowering, the raising of the same. Next, stabilize or destabilize the telehandler according to the operation needed.

To stabilize the telehandler:

- Extend the stabilizer beams.
- Fully lower the beams with the 4 stabilizing feet so that they rest on the ground and stabilize the machine.

The stabilizers are controlled electronically and the extension / retraction and raising / lowering speed can be adjusted proportionally and via the display.

To move the stabilizers, the operator must check that different conditions exist.

#### Conditions for stabilizers extension block:

- Red emergency mushroom button pressed.
- Operator not seated.
- Seat belt not fastened and door open.
- With the suspension, road mode active. (depending on machine model)
- Telescopic boom completely closed,
- Telescopic boom raised to a height over 3m / 9.8ft.

#### Conditions for stabilizer retraction block:

- Red emergency mushroom button pressed.

- Operator not seated.
- Seat belt not fastened and door open.
- With the suspension, road mode active. *(depending on machine model)*
- Telescopic boom completely closed.
- Telescopic boom raised to a height over 3m / 9.8ft.
- Boom angle over 55° degrees.
- Telescopic boom over 3 m / 9.8 ft if the turret is not centered on the undercarriage over +/- 5° degrees.
- Telescopic boom not closed.
- With attachment for lifting people, if the telescopic boom is at a height over 3 m / 9.8 ft.
- With the attachment for lifting people, if the telescopic boom is not closed.

#### Conditions for stabilizers descent block

- Red emergency mushroom button pressed.
- Operator not seated.
- Seat belt not fastened and door open.
- With the suspension, road mode active. *(depending on machine model)*
- Telescopic boom completely closed.

#### Conditions for stabilizer ascent block

- Red emergency mushroom button pressed.
- Operator not seated.
- Seat belt not fastened and door open.
- With the suspension, road mode active. *(depending on machine model)*
- Telescopic boom completely closed.
- Telescopic boom raised to a height over 3m / 9.8ft.
- Boom angle over 55° degrees.
- Telescopic boom over 3 m / 9.8 ft if the turret is not centered on the undercarriage over +/- 5° degrees.
- Telescopic boom not closed.
- With attachment for lifting people, if the telescopic boom is at a height over 3 m / 9.8 ft.
- With the attachment for lifting people, if the telescopic boom is not closed.

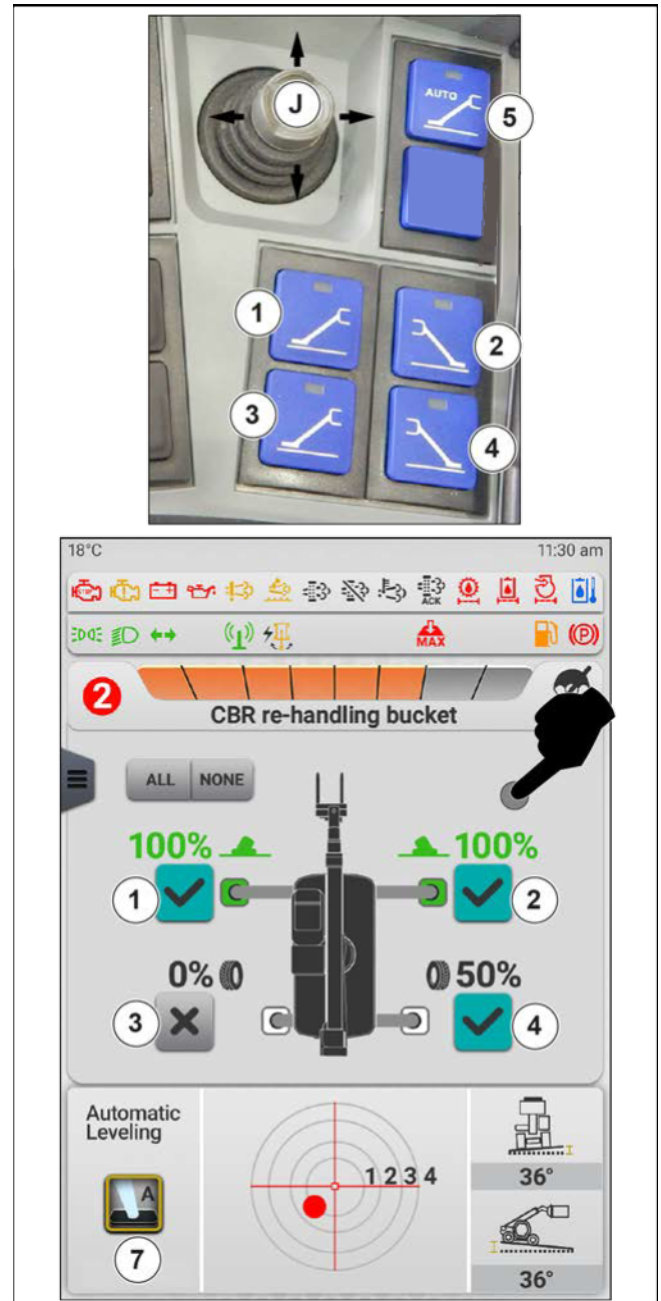

Figure 135: Manual stabilization procedure

### 3.6.5 AUTOMATIC STABILIZATION PROCEDURE



The function is present from software version 1.2.25 or later.

The sequence of the self-stabilization or self-destabilization feature will follow the same logic as the manual one and can be activated by the operator to improve and maximize his work.

To operate these stabilization / destabilization automatism, even if managed electronically, certain block conditions must not exist, the same as described for the manual procedure.

### 3.6.6 STABILIZERS AUTOMATIC LEVELING PROCEDURE

The machine is equipped with a device for leveling the stabilizers, with respect to the ground in order to level the machine and then raise the boom to the maximum height in complete safety and stability.

#### Device operation

Before leveling the machine it is necessary to select the four stabilizers, keys (1, 2, 3, 4).

Select the "STABILITY" page on the display and at the bottom keep the button (7) pressed until the machine is leveled and stabilized.

On the display, check the machine level and stabilized indicators.

To enable automatic leveling of stabilizers, the operator must:

- Close the cabin door.
  - Place the gear lever on neutral.
  - Extend the stabilizer beams more than 40%.
  - Fully retract the telescopic boom.
- Check that you are positioned:
- With front turret (no more than +/- 5° of rotation) and telescopic boom tilt of less than 55°.
  - With turret rotated (more than +/- 5° of rotation) and telescopic boom raised to a height of less than 3 m / 9.8 ft.

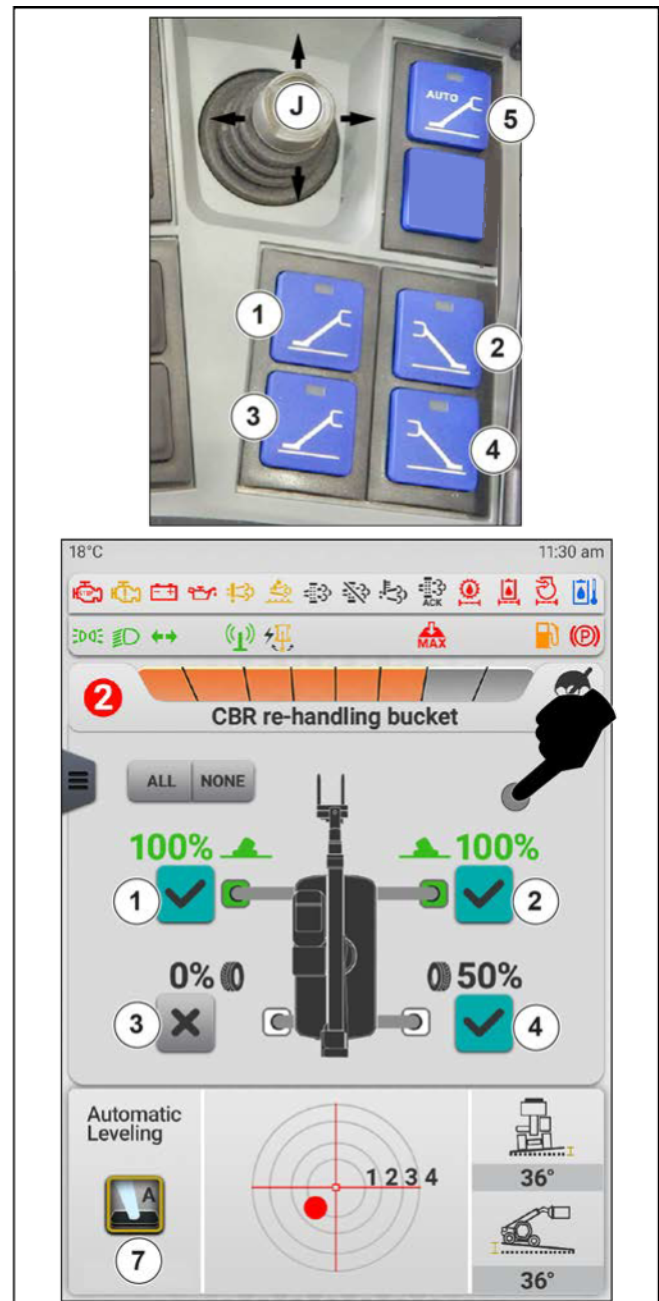

Figure 136: Automatic stabilization procedure

## 3.7. EMERGENCY PROCEDURES

### 3.7.1 EMERGENCY PROCEDURE

In case of emergency, if the safety system needs to be disabled, the operator must:

- Take the hammer (1) on the safety box (2).
- Break the protective glass (3) of the safety box (2).
- Take the key (4) and insert it in the key selector (5).
- Turn the key selector (5) to the " " position to disable the safety system.

Press and keep the key selector (5) turned (4) to “ “ position to proceed and continue to operate with the emergency maneuvers, making movements opposite to those that can generate instability and / or overload of the vehicle.



*When the safety system is disabled, an acoustic alarm and a visible indicator (steady red light above the cabin) are automatically activated to warn the driver and any personnel outside the vehicle of a possible dangerous situation.*



*Once the emergency procedure is completed, put the key (5) back inside the safety box (2) and replace the protective glass (3).*



Figure 137: Emergency procedure

## 3.8. USE OF TOWING DEVICES

### 3.8.1 PIN AND TOWING HOOK

Located at the back of the telehandler, this device allows you to hook up a trailer.

For each telehandler, the capacity is limited by the total permitted working weight, the tractive force and the maximum lift capacity on the coupling point.

To use a trailer, consult the regulations in force in your country (maximum travel speed, braking, maximum weight of the trailer, etc.). Check the condition of the trailer before using it (tire condition and pressure, electrical socket, hose).

## ⚠ DANGER

### Risk of damage to the handler's steering and braking devices

Using a trailer that is in poor condition could damage the steering and braking devices of the telehandler, and therefore compromise the safety of the machine.

Do not tow a trailer or attachment that is not in perfect working order.

## ⚠ DANGER

If the trailer coupling or uncoupling operations are carried out by someone else, that person must always be visible to the driver.

Before working on the trailer, wait for the telehandler to stop, the service brake to be applied and the combustion engine to be turned off.



*A rear view mirror allows for a more precise approach of the telehandler towards the trailer ring.*

### 3.8.2 COUPLING FORK

#### Trailer coupling and uncoupling

- To hitch, move the telehandler as close as possible to the trailer ring.
- Apply the parking brake and switch off the heat engine.
- Remove the split pin 1, raise the tow pin 2, and position or remove the trailer ring.

## ⚠ DANGER

### Risk of pinching or crushing

There is the risk of pinching or crushing during the maneuver.

Don't forget to put the split pin 1 back. When uncoupling, make sure the trailer is standing on its own.



Figure 138: Coupling fork

## 3.9. TRANSPORT OF THE MACHINE

### 3.9.1 TRANSPORTING THE TELESCOPIC HANDLER ON A TRAILER

Check that the safety recommendations relating to the transport platform have been followed before loading the telehandler, and verify that the driver of the means of transport is informed of the dimensional characteristics and weight of the telehandler.

Before loading the telehandler, check on the display that the turret aligned and centered indicator is on.

Afterwards, it is necessary to block the rotation of the turret using the safety pin supplied with the telescopic handler.

### **⚠ DANGER**

#### **Risk of overturning**

Make sure the platform is large enough and has the load capacity to transport the telehandler. Also check the allowed ground contact pressure for the platform with respect to the telehandler.

#### **Blocking the rotation of the telehandler turret**

1. Park the vehicle in a flat, unobstructed area.
2. Align and center the turret.
3. Stop the vehicle.

4. Open the hood behind the cabin to take out the safety pin (1) supplied with the machine.
5. Unscrew the screw (2) that fixes the pin in its seat. Remove the pin and screw.
- 6.

### **⚠ DANGER**

#### **Risk of crushing**

To position the safety pin, access the walkable surface above the vehicle's undercarriage via the right side ladder.

During the safety pin positioning procedure, do not stand under the telescopic boom.

Insert the pin (1) in the seat on the turret (3) and slide it down as far as it will go.

7. Secure the pin with its fixing screw (2).



*After unloading the telehandler from the transport platform, extract the safety pin for blocking the turret rotation and put it back in its resting seat (4).*

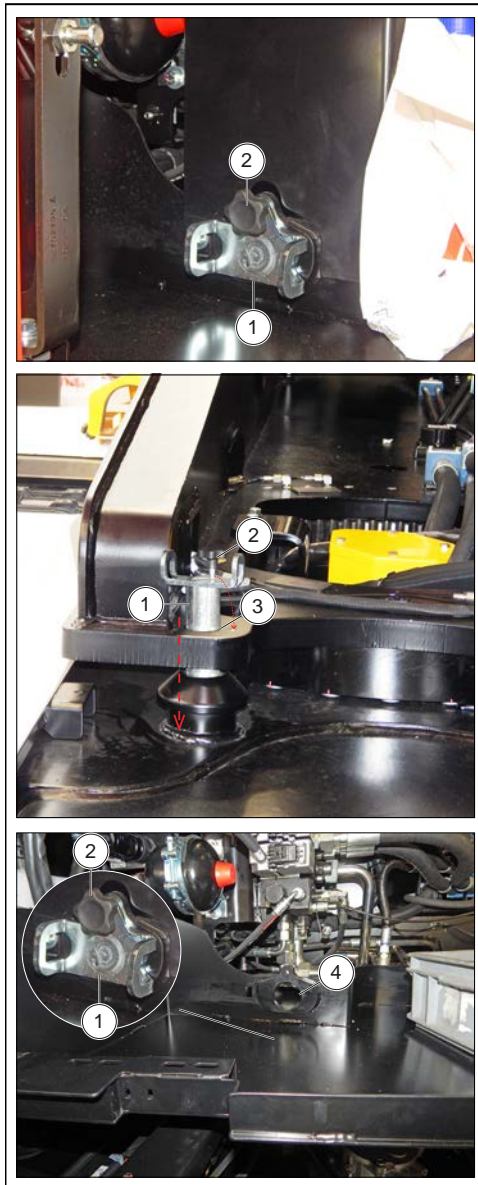

Figure 139: Blocking turret rotation

### Load the telehandler

1. Block the wheels of the transport platform.
2. Fasten the loading ramps to the platform so that the smallest possible angle for lifting the telehandler is achieved.
3. Load the telehandler parallel to the platform.
4. Switch off the telehandler.

**⚠ DANGER**

### Danger of overturning

In case of loading of the telescopic handler on the transport platform by radio remote controlled driving, the operator must:

- maintain a safety distance of at least 3 m from the vehicle itself and which allows a good view of the loading operations, but which allows escape in the event of accidental overturning or rolling of the vehicle from the platform;
- make sure there is nobody in the loading area;
- make sure there is nobody in the cabin.

### Putting the telehandler in a harness

1. Secure wedges in front of and behind each tire.
2. Block the telehandler to the platform with sufficiently strong ropes or chains on the front and rear of the telehandler at the anchorage points (1).
3. Tighten the ropes or chains.

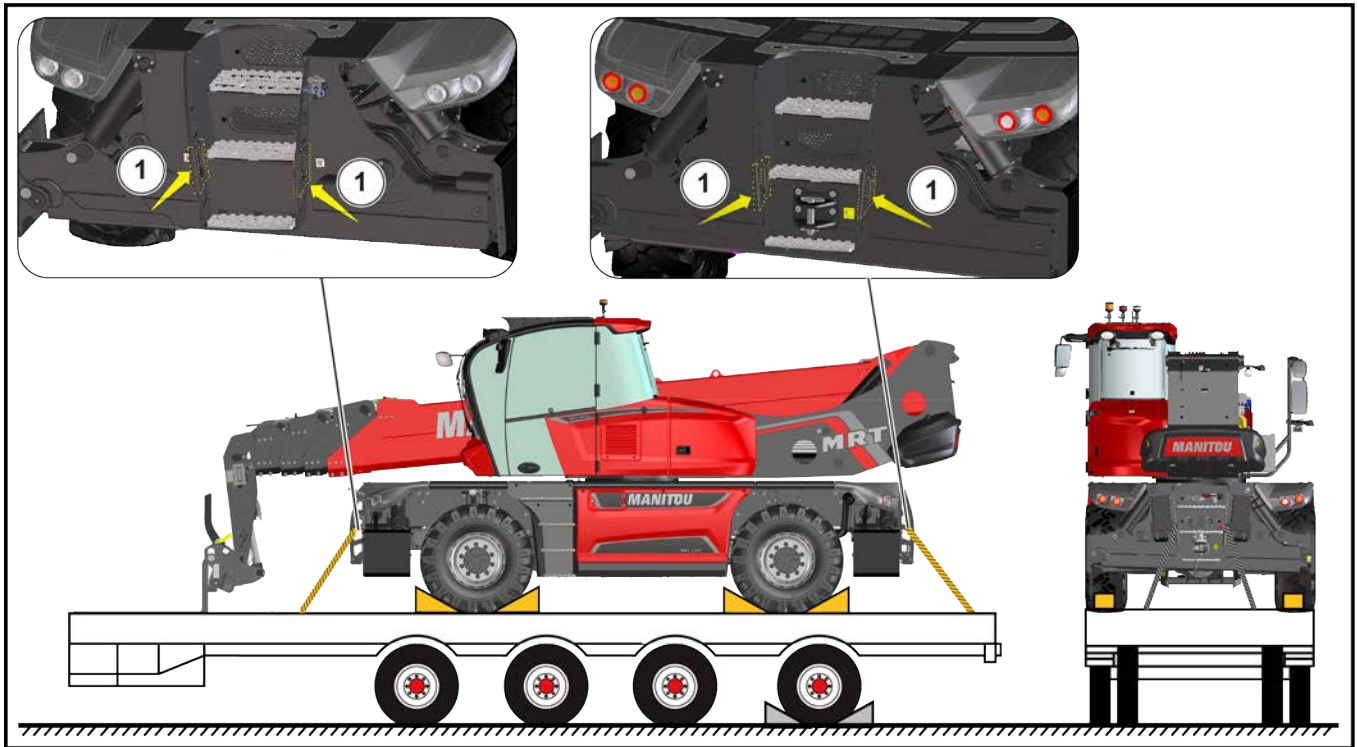

Figure 140: Putting the telehandler in a sling

### 3.9.2 PUTTING THE TELEHANDLER IN A SLING AND LIFTING IT

Take into account the position of the center of gravity of the telehandler for lifting.

Position the bands in the anchoring seats provided: the ends of the front (1) and rear (2) stabilizing beams.

Extend the beams until they protrude from the shape of the machine so that the operator does not find obstacles during the insertion of the bands and during the lifting phase.

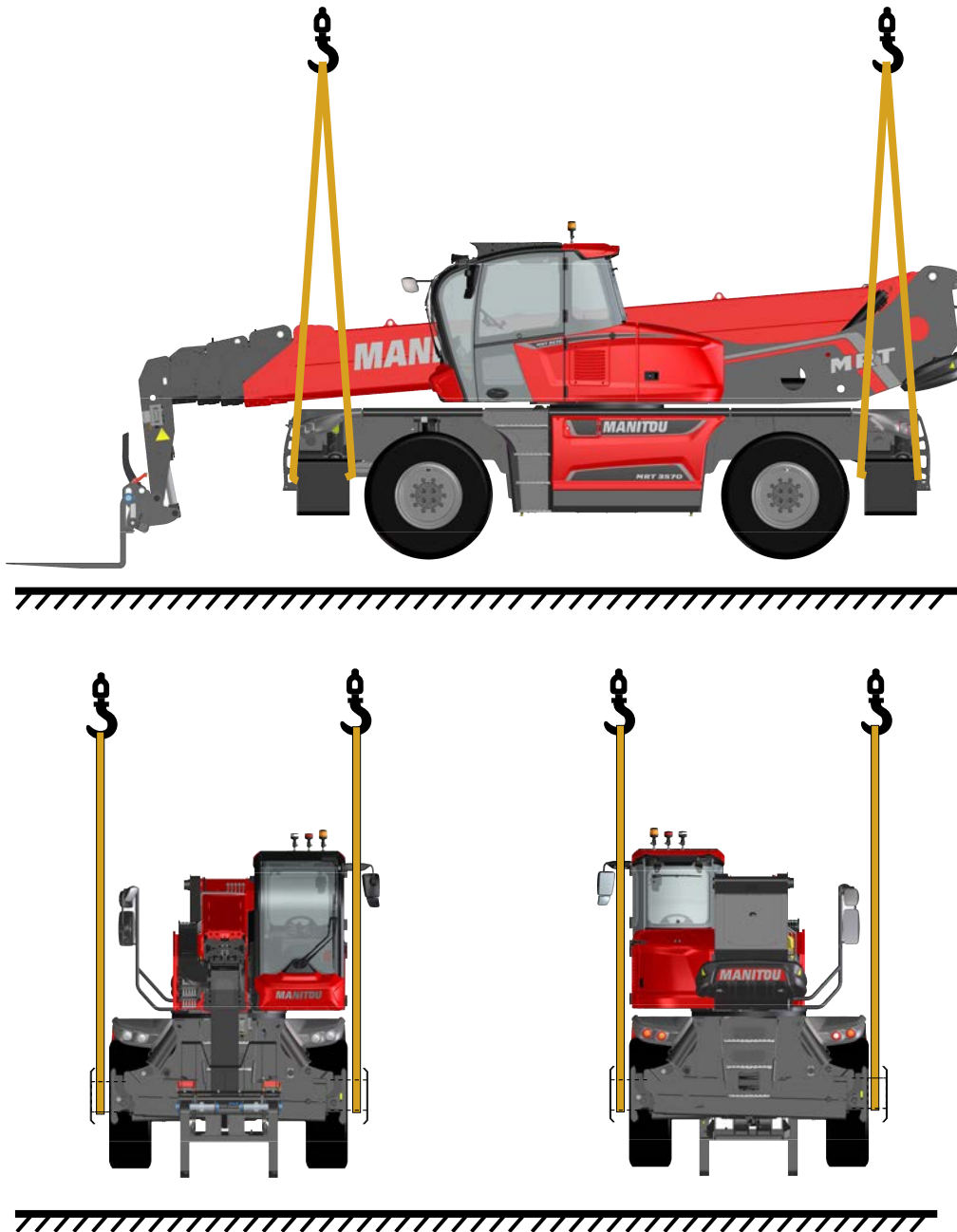

Figure 141: Putting the telehandler in a sling and lifting it

### 3.9.3 TOWING OR HOOKING THE TELEHANDLER

**MRT2260, MRT2660, MRT2570, MRT3050, MRT-X2260, MRT-X2660, MRT-X2570, MRT-X3050**



*Towing can be done at very low speed and for short distances.*

#### How to operate

Press the forward-reverse direction selector in neutral "N".

Release the parking brake.

Turn on the hazard warning lights.

Shift the gear into neutral on the gearbox:

1. Disconnect and plug the hydraulic hoses (1) from the jack of the low / high gearbox.
2. Leverage the stem (2) of the gearbox to make it come out and bring it to the neutral position (intermediate position between the two "next clicks").
3. Unblock the negative brake:  
With locknut, tighten the negative brake release screws (3), positioned on the two sides of the front axle housing until they rest with the piston. At this point, make a rotation of one turn.

In the absence of hydraulic steering and power brake assistance, act slowly and vigorously on these two controls.

Avoid sudden movements and jerks.

**!** *It is crucial that opposite screws are tightened the same amount.*

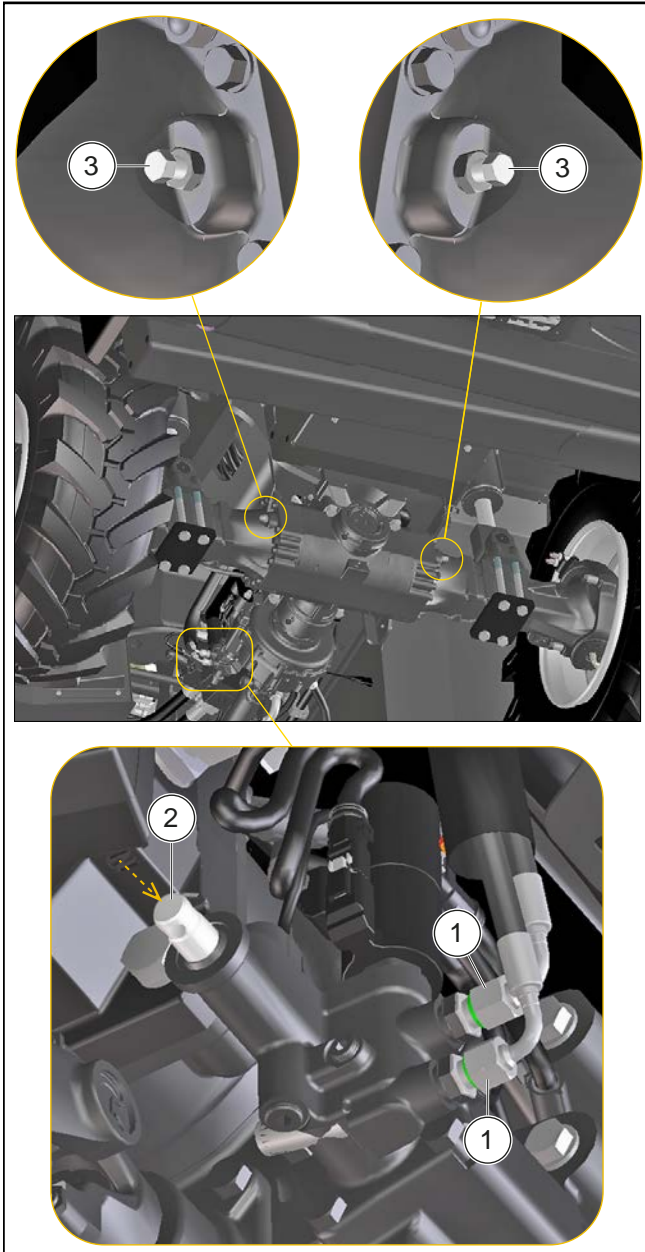

Figure 142: Towing or hooking the telehandler

### 3.9.4 TOWING OR HOOKING THE TELEHANDLER

**MRT3570, MRT3570 ES, MRT-X3570, MRT-X3570 ES**

**!** *Towing can be done at very low speed and for short distances.*

#### How to operate

Press the forward-reverse direction selector in neutral "N".

Release the parking brake.

Turn on the hazard warning lights.

Activate the bypass feature on the hydrostatic pump to allow the hydraulic oil to flow freely.

**To activate the bypass feature:**

1. Turn off the engine.
2. Use an Allen key (WAF 8) to turn the diverter valve (1) counterclockwise until it stops (2). The bypass feature is now active.

**! DANGER**

Immediately after towing, deactivate the bypass feature.

**To deactivate the bypass feature:**

1. Use an Allen key (WAF 8) to turn the diverter valve (1) clockwise until it stops and tighten it with a tightening torque of 50 Nm. The bypass feature is no longer active.

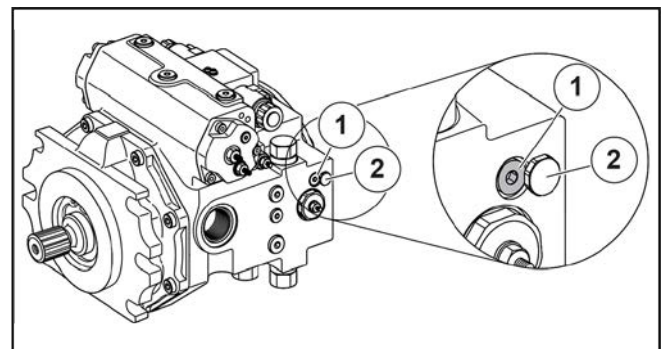
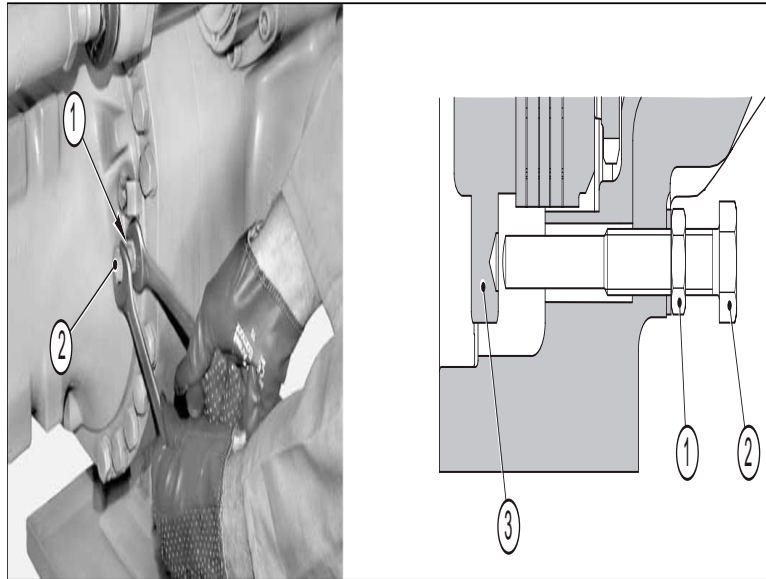

Figure 143: Hydrostatic pump bypass

**Mechanical release of the negative brake on front and rear axles**

- Loosen the locknuts (1) of the screws (2) of the manual mechanical release. Back off the nuts by  $\pm 8$  mm.
- Screw the screws (1) until they are fully seated on the pressure plate (3).



#### Adjustments after each manual release

- Remove the screws (2) complete with nuts (1) and gaskets (4).
- Replace the gaskets (4), lubricate the screws (2) with silicone grease and reassemble the complete screws (1-2-4).

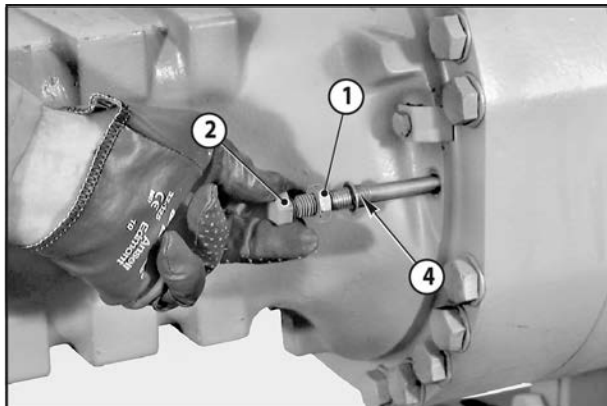

- Block the position of the screws (2) with the locknuts (1).

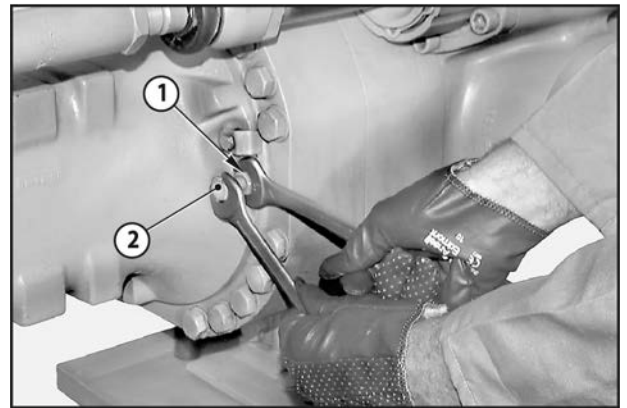

*Double check the protrusions of the screws carefully.*

- Adjust the projection of the screw heads with respect to the bridge boom to a value of 34 mm.

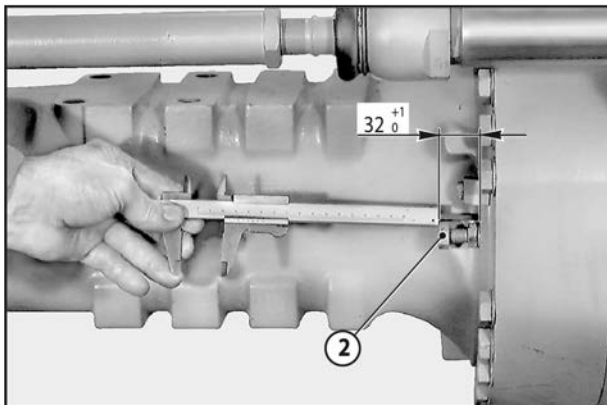

## 4. MAINTENANCE

### 4.1. MAINTENANCE INTERVALS

If the telehandler has not reached 500 hours of operation within the first 6 months, perform the 1st mandatory service at the dealership.

#### 4.1.1 DAILY AND WEEKLY MAINTENANCE



*The operator is authorized to perform this maintenance.*

These maintenance interventions allow the operator to keep the telehandler in a clean and safe condition.

#### 4.1.2 1ST MANDATORY SERVICE WITHIN THE FIRST 500 HOURS OR WITHIN 6 MONTHS



*This service must be carried out within the first 500 hours of operation or within 6 months from the commissioning of the telescopic handler (within the first deadline reached).*

#### 4.1.3 PERIODIC MAINTENANCE



Periodic maintenance should be performed by an authorized Manitou network professional.

#### Maintenance intervals calendar

This calendar allows the operator to keep up to date the periodic maintenance work carried out on the telehandler by notifying the total number of hours carried out and the date of the overhaul carried out by the authorized professional of the MANITOU network.

#### 4.1.4 MAINTENANCE AND OCCASIONAL OPERATIONS

The following work and operations must be carried out according to the safety and maintenance requirements of the telehandler.

### 4.2. SCHEDULED MAINTENANCE

#### 4.2.1 1ST MANDATORY SERVICE WITHIN THE FIRST 500 HOURS OR WITHIN 6 MONTHS

##### **First 500 hours before the initial 6 months.**

If the telehandler has reached 500 hours prior to 6 months of service, perform the 1st mandatory service and the 500-hour periodic maintenance.

##### **First 6 months before the initial 500 hours.**

## 1st mandatory service

Table 87. 1st mandatory service

| <b>Operation</b> | <b>Description</b>                         | <b>Notes</b> |
|------------------|--|--------------|
| Check            | Oil level in the gearbox                   |              |
| Check            | Tire pressure                              |              |
| Check            | Tightening the wheel nuts                  |              |
| Check            | Differential seal of the front axle        |              |
| Check            | Differential seal of the rear axle         |              |
| Check            | Seal of the front wheel reducers           |              |
| Check            | Seal of the rear wheel reducers            |              |
| Check            | Tightening the telescopic boom shoes       |              |
| Check            | Hydraulic and transmission oil level       |              |
| Check            | Windscreen washer fluid level              |              |
| Check            | Cabin ventilation filters                  |              |
| Clean            | Radiator grille                            |              |
| Clean            | Condenser grille (Air conditioning OPTION) |              |
| Lubricate        | General lubrication                        |              |
| Check            | Wear of the forks                          |              |
| Check            | Safety belt                                |              |
| Check            | Silent Block of the three-phase motor      |              |
| Check / Adjust   | Suction system of the three-phase motor    |              |
| Check            | Hoses and harness of the three-phase motor |              |
| Check            | Brake circuit pressure                     |              |
| Check            | Wear of the boom shoes                     |              |
| Check            | Condition of harness and cables            |              |
| Check            | Lighting and signaling                     |              |
| Check            | Signalers                                  |              |
| Check            | Condition of rear view mirrors             |              |
| Check            | Cabin structure integrity                  |              |
| Check            | Chassis structure integrity                |              |
| Check            | Quick coupling of attachments              |              |
| Check            | Condition of attachments                   |              |

### 4.2.2 DAILY AND WEEKLY MAINTENANCE

#### 10h - Daily maintenance or every 10 hours of operation

Table 88. 10h - Daily maintenance or every 10 hours of operation

| <b>Operation</b> | <b>Description</b>            | <b>Notes</b> |
|------------------|-------------------------------|--------------|
| Check            | Engine oil level              |              |
| Check            | Coolant level                 |              |
| Check            | Telescopic boom sliding shoes |              |
| Verify           | "MSS" safety system           |              |
| Check            | Fuel level                    |              |
| Check            | DEF liquid level              |              |

| <b>Operation</b> | <b>Description</b>     | <b>Notes</b> |
|------------------|------------------------|--------------|
| Check            | Fuel prefilter         |              |
| Check            | Cabin glass for damage |              |

### 50h - Weekly maintenance or every 50 hours of operation

Table 89. 50h - Weekly maintenance or every 50 hours of operation

| <b>Operation</b>    | <b>Description</b>                           | <b>Notes</b> |
|---------------------|--|--------------|
| Check               | Hydraulic oil level                          |              |
| Check               | Tire pressure and wheel nut tightening       |              |
| Clean               | Water oil cooler grille of intercooler       |              |
| Clean and lubricate | Telescopic boom wear shoes                   |              |
| Lubricate           | Front and rear side crosses and cardan shaft |              |
| Lubricate           | Front / rear pins of stabilizer feet         |              |
| Clean and lubricate | Turret rotation ring                         |              |
| Check               | Windshield washer fluid level                |              |
| Check and Clean     | Condenser grille (Optional Air Conditioning) |              |
| Lubricate           | Pins of front and rear wheel reducers        |              |

### 250h - Every 250 hours of operation

Table 90. 250h - Every 250 hours of operation

| <b>Operation</b>           | <b>Description</b>                         | <b>Notes</b> |
|----------------------------|--|--------------|
| Check                      | Front and rear axle differential oil level |              |
| Check                      | Front and rear wheel reducers oil level    |              |
| Check                      | Gearbox oil level                          |              |
| Check                      | Battery                                    |              |
| Check                      | Turret rotation reducer oil level          |              |
| Check, clean and lubricate | External boom chains                       |              |
| Check                      | Rotation reducer fixing screws             |              |
| Clean and lubricate        | Cabin door hinges                          |              |

## 4.2.3 PERIODIC MAINTENANCE

### 500h - Periodic maintenance - every 500 hours of operation or 6 months

Table 91. 500h - Periodic maintenance - every 500 hours of operation or 6 months

| <b>Operation</b> | <b>Description</b>                         | <b>Notes</b> |
|------------------|--|--------------|
| Check            | Contamination of hydraulic oil             |              |
| Replace          | Hydrostatic pump (transmission) oil filter |              |
| Replace          | Hydraulic oil filter cartridge (drain)     |              |
| Replace          | Hydraulic oil breather                     |              |
| Check            | Fifth wheel and turret fixing bolts        |              |

| <b>Operation</b> | <b>Description</b>        | <b>Notes</b>        |
|------------------|---------------------------|---------------------|
| Check            | Wear of the forks         | Contact your dealer |
| Check            | Cabin ventilation filters |                     |

### 1000h - Periodic maintenance - every 1000 hours of operation or 1 year



Also carry out periodic maintenance of the 500 hours of operation.

Table 92. 1000h - Periodic maintenance - every 1000 hours of operation or 1 year

| <b>Operation</b>    | <b>Description</b>                                       | <b>Notes</b>  |
|---------------------|--|---|
| Replace             | Engine oil and filter                                    |   |
| Replace             | Front and rear axle differential oil                     |   |
| Replace             | Front and rear wheel reducer oil                         |   |
| Replace             | Gearbox oil  |   |
| Replace / Clean     | Gearbox oil and speed sensor                             | Just for: MRT 3570 ES, MRT-X 3570 ES                        |
| Replace             | Dry air filter cartridge                                 |   |
| Clean               | Fuel tank  |   |
| Replace             | Fuel pre-filter  |   |
| Check / Clean       | Fuel pump filter   |   |
| Replace             | Fuel filter  |   |
| Replace             | Coolant  |   |
| Replace             | Cabin ventilation filters                                |   |
| Check               | Wear of the external chains of the telescopic boom       |   |
| Replace / Lubricate | Turret rotation reducer oil / rotation reducer bearings  |   |
| Verify              | Wear and increased clearance of the fifth wheel bearings |   |
| Replace             | "DEF" boost pump filter                                  |   |
| Replace             | "DEF" tank breather                                      |   |
| Check               | Safety belt  |   |
| Check               | Silent Block of the three-phase motor                    | Contact your dealer   |
| Check / Adjust      | Three-phase motor air intake system                      | Contact your dealer   |
| Check               | Three-phase motor hoses and pipes                        | Contact your dealer   |
| Check               | Brake circuit pressure                                   | Contact your dealer   |
| Check               | Wear of the telescopic boom shoes                        | Contact your dealer   |
| Check               | Condition of harnesses and cables                        | Contact your dealer   |
| Check               | Lighting and signaling                                   | Contact your dealer   |
| Check               | Signalers  | Contact your dealer   |
| Check               | Condition of rear view mirrors                           | Contact your dealer   |
| Check               | Cabin structure integrity                                | Contact your dealer   |
| Check               | Chassis structure integrity                              | Contact your dealer   |
| Check               | Integrity of arms and suspension linkages                | Just for: MRT 3570 ES, MRT-X 3570 ES<br>Contact your dealer |
| Check               | Quick coupling of attachments                            | Contact your dealer   |
| Check               | Condition of attachments                                 | Contact your dealer   |
| Check               | Service and parking brake                                | Contact your dealer   |

### 2000h - Periodic maintenance - every 2000 hours of operation or 2 years

 Also carry out periodic maintenance of the 500 hours and 1000 hours of operation.

Table 93. 2000h - Periodic maintenance - every 2000 hours of operation or 2 years

| Operation      | Description                               | Notes               |
|----------------|---|---------------------|
| Check          | Tire pressure and wheel nut tightening    |                     |
| Replace        | Hydraulic oil                             |                     |
| Clean          | Hydraulic system intake filter cartridges |                     |
| Check          | Radiator                                  | Contact your dealer |
| Check          | Transmission pressures                    | Contact your dealer |
| Check          | Steering                                  | Contact your dealer |
| Check          | Condition of the boom assembly            | Contact your dealer |
| Check          | Bearings and articulation rings           | Contact your dealer |
| Check          | Conditions of hoses and pipes             | Contact your dealer |
| Check          | Condition of jacks (leak, rods)           | Contact your dealer |
| Check          | Pressures of hydraulic circuits           | Contact your dealer |
| Check          | Bearings and articulation rings           | Contact your dealer |
| Clean / Check  | Air conditioning (OPTIONAL)               | Contact your dealer |
| Check / Adjust | Engine valve clearance                    | Contact your dealer |

### 3000h - Periodic maintenance - every 3000 hours of operation or 3 years

 Also carry out periodic maintenance of the 500 hours and 1000 hours of operation.

Table 94. 3000h - Periodic maintenance - every 3000 hours of operation or 3 years

| Operation | Description                    | Notes |
|-----------|--------------------------------|-------|
| Replace   | Air filter safety cartridge    |       |
| Replace   | Three-phase motor service belt |       |

### 4500h - Periodic maintenance - every 4500 hours of operation or 9 years

 Also carry out periodic maintenance of the 500 hours of operation.

Table 95. 4500h - Periodic maintenance - every 4500 hours of operation or 9 years

| Operation     | Description   | Notes               |
|---------------|---|---------------------|
| Check         | Three-phase motor crankcase breather  |                     |
| Replace       | Motor breather crankcase filter   |                     |
| Check         | Control unit (ECU), sensors and actuators associated with the three-phase motor | Contact your dealer |
| Check         | Three-phase motor turbocharger  | Contact your dealer |
| Check / Clean | Valve of the exhaust gas recirculation (EGR) system of the three-phase motor    | Contact your dealer |

| <b>Operation</b> | <b>Description</b>   | <b>Notes</b>        |
|------------------|--|---------------------|
| Check            | Selective Catalytic Reducer (SCR) / Diesel Oxidation Catalyst (DOC) of the three-phase motor | Contact your dealer |
| Check / Clean    | Three-phase motor injector   | Contact your dealer |

### 6000h - Periodic maintenance - every 6000 hours of operation or 12 years



Also carry out periodic maintenance of the 500 hours, 1000 hours, 2000 hours or 3000 hours of operation.

Table 96. 6000h - Periodic maintenance - every 6000 hours of operation or 12 years

| <b>Operation</b> | <b>Description</b>                                       | <b>Notes</b>        |
|------------------|--|---------------------|
| Check            | Diesel Particulate Filter (DPF) of the three-phase motor | Contact your dealer |

### 9000h - Periodic maintenance - every 9000 hours of operation or 18 years



Also carry out periodic maintenance of the 500 hours, 1000 hours, 3000 hours or 4500 hours of operation.

Table 97. 9000h - Periodic maintenance - every 9000 hours of operation or 18 years

| <b>Operation</b> | <b>Description</b>   | <b>Notes</b>        |
|------------------|--|---------------------|
| Replace          | Diesel Particulate Filter (DPF) of the three-phase motor   | Contact your dealer |
| Replace          | Selective Catalytic Reducer (SCR) of the three-phase motor | Contact your dealer |

## 4.2.4 OCCASIONAL MAINTENANCE

Table 98. Occasional maintenance

| <b>Operation</b> | <b>Description</b>   | <b>Notes</b> |
|------------------|--|--------------|
| Install          | Telescopic boom safety wedge   |              |
| Replace          | Wheel  |              |
| Regular          | Headlights   |              |
| Replace          | Fuses and relays   |              |
| Check / clean    | Rotating electric collector transmitter rings (after 3 months of inactivity) |              |
| Verify           | Radio control  |              |
| Check / Clean    | Fuel tank filler filter  |              |
| Check / Clean    | DEF tank filler filter   |              |
| Clean            | Stationary regeneration of DPF filter "Handler stopped"                      |              |

## 4.3. EVERY 10 HOURS OF OPERATION

### 4.3.1 CHECKING THE OIL LEVEL IN THE ENGINE

**⚠ DANGER**

**Risk of damage to the engine or exhaust after-treatment unit**

Do not add too much oil. Adding too much oil can cause damage to the engine or the exhaust after-treatment unit.

Drain or suck up excess oil.

Place the telehandler on a level surface with the heat engine off, and let the oil settle in the crankcase.

- Open the hood.
- Remove the dipstick (1).
- Clean the dipstick and check that the level is between the two marks.
- If necessary, remove the cap (2) on the cylinder head and add new oil through the filler port (3).
- Look to make sure that there are no leaks or sweating.

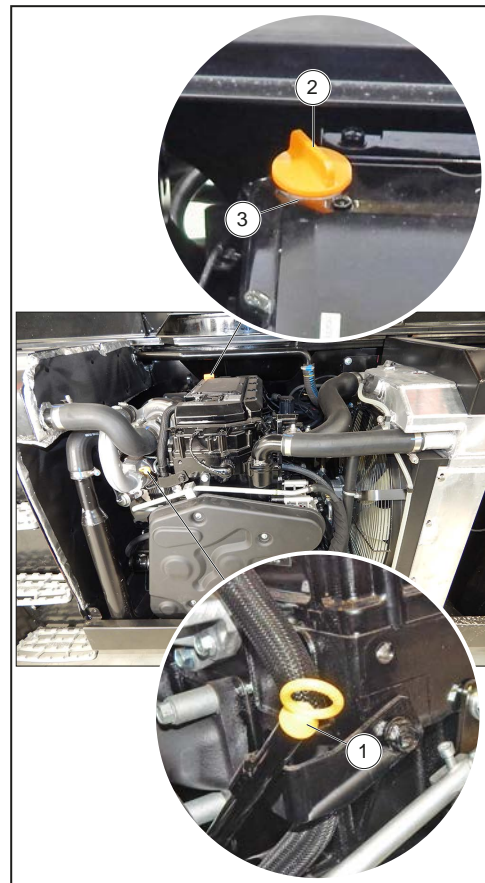

Figure 144: Engine oil level

### 4.3.2 CHECKING THE COOLANT LEVEL

**⚠ WARNING**

**Risk of getting a burn**

Pressurized system: Hot coolant can cause severe burns.

When opening the filler cap, stop the engine and wait for the cooling system components to cool. Loosen the pressure cap slowly to relieve pressure. Never add cold coolant when the engine is hot. In an emergency, it is possible to use water as a coolant, and then proceed, as quickly as possible, to change the fluid in the cooling circuit.

**⚠ DANGER**

**Risk of introducing an air lock into the cooling system**

When performing any maintenance or repair of the engine cooling system, the procedure must be performed with the engine at ground level.

This allows you to accurately check the coolant level and avoid the risk of introducing an air lock into the cooling system.

- Open the hood.
- Check the correct level in relation to the center of the indicator (1).
- If necessary, add coolant.
- Slowly pull the radiator cap (2) up to the safety stop.
- Let the pressure and steam escape.
- Press the cap and remove it by turning.
- Add coolant through the fill orifice (3) up to the center of the indicator (1).
- Slightly lubricate the fill orifice to make it easier to replace and remove the radiator cap.
- Look to make sure that there are no leaks on the radiator or pipes.

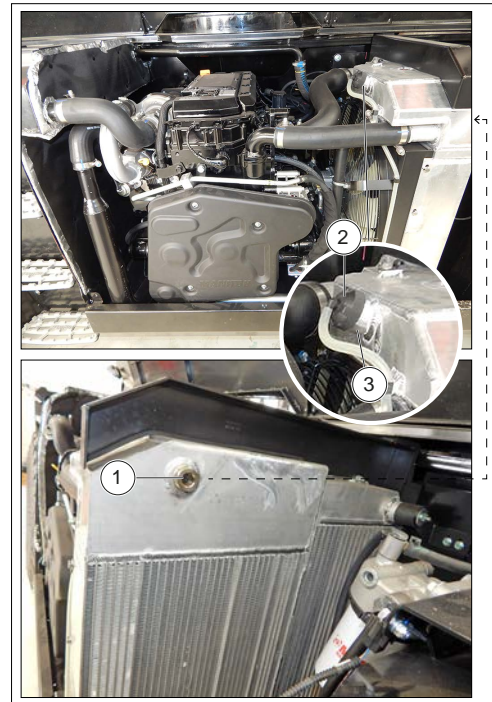

Figure 145: Coolant level

### 4.3.3 CHECKING THE TELESCOPIC BOOM SLIDING SHOES

To maintain optimum operation, keep the sliding shoes and telescopic boom extensions lubricated.

## NOTICE

LUBRICATION OF THE TELESCOPIC BOOM  
REQUIRED AFTER:

Cleaning the boom, especially with high pressure lances.  
Long period of non-use of the telescopic handler.

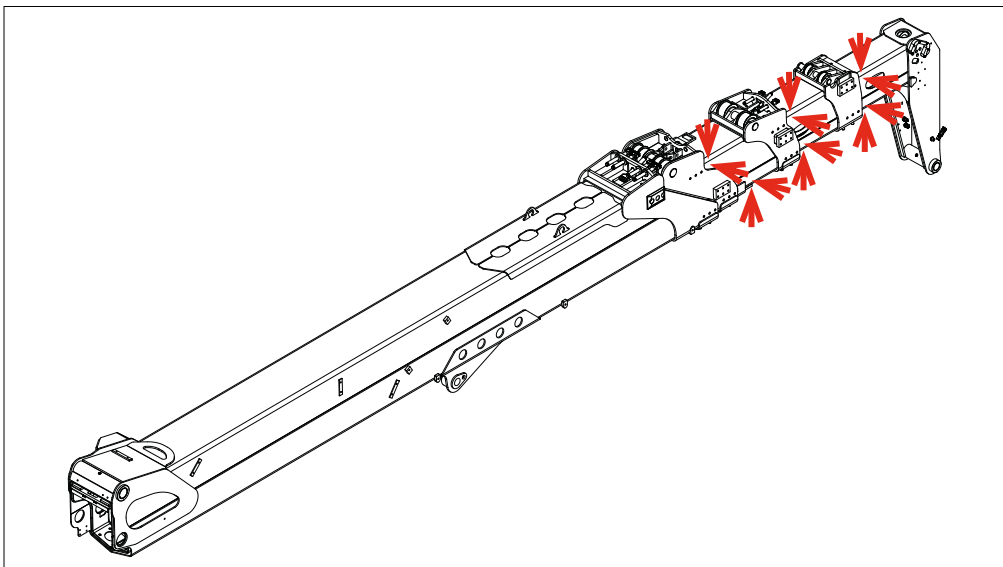



Figure 146: Telescopic boom sliding shoes

1. Fully extend the telescopic boom extensions.
2. Check the condition of the surface of the telescopic extensions: clean surface, without signs of corrosion.
  - 2.1. clean surface, without signs of corrosion.
3. If necessary, lubricate the telescopic boom extensions with specific grease to maintain the correct sliding of the sliding shoes:
  - 3.1. Extend and retract the boom several times to spread the grease evenly.
4. Remove excess grease.

 *In case of use in an abrasive atmosphere (dust, sand, coal) use a sliding paint (reference MANITOU: 483536). Get advise from your dealer.*

### 4.3.4 CHECKING THE "MSS" SAFETY SYSTEM

1. With the help of a metric cord and a spirit level check the indications of boom length (L) and angle (A).
2. Then check the operation of the safety system by lifting a known weight, with forks, with the boom closed, and checking that the reading of the load on the display (1) is correct (WORKING page, "Geometrical" selection).
3. Extend the load (keeping it about 0.5 m / 1.6 ft from the ground) and check that it reaches the limit set by the load chart and that the telescopic handler blocks aggravating movements when the "MSS" safety system is activated



Figure 147: "MSS" safety system

### 4.3.5 CHECKING THE FUEL LEVEL

Keep the fuel tank as full as possible to minimize condensation due to atmospheric conditions.

** DANGER**

#### Risk of fire and explosion

Do not smoke or come close with an open flame during filling operations or when the tank is open.

Never fill up while the engine is running.

- Check the indicator on the display (DRIVE page).
- If necessary, add diesel fuel.
- Open the flap (1) using the ignition key to see the fuel filler neck (3).
- Remove the cap (2).
- Fill the tank with clean and filtered diesel fuel through the filler neck (3).
- Put the cap (2) back on.
- Look to make sure that there are no leaks on the tank or pipes.



Figure 148: Fuel level

### 4.3.6 CHECKING DEF LIQUID LEVEL

#### ⚠ WARNING

##### Risk of contact with irritants

If the "DEF" tank cap is opened in high temperatures, ammonia vapors may escape. Ammonia vapors have a pungent odor and are particularly irritating to the skin, mucous membranes and eyes. The presence of the vapors can cause a burning sensation in the eyes, nose and oral cavities as well as coughing and watery eyes.

Do not inhale ammonia vapors.

#### ⚠ WARNING

##### Risk of contact with irritants

If "DEF" comes into contact with eyes or skin, rinse immediately and thoroughly with clean water. If "DEF" is swallowed, rinse your mouth immediately with plenty of clean water and drink plenty of water. Change clothing soiled with "DEF" immediately. In case of allergic reactions, go to a doctor immediately for advice.

Keep "DEF" out of the reach of children. "DEF" must not come into contact with the skin, eyes or clothing.

#### ⚠ WARNING

##### Risk of getting a burn

During operation and after the engine has stopped, "DEF" pipes and all connected components remain under pressure and can be very hot. When opening the system, there is the risk of being burnt by high temperature "DEF" sprays.

Start work on the exhaust gas after treatment system no sooner than at least 5 minutes after the engine has been stopped. Slowly open the piping connections and blocking elements of the system components. When opening, cover the sectioning point with a piece of cloth. Wear protective gloves, clothing and goggles.

#### ⚠ DANGER

##### Risk of damage to thermostats and temperature sensors

The penetration of "DEF" into the coolant circuit (even a tiny amount) damages the thermostats and temperature sensors.

It is highly recommended to keep "DEF" separated from other consumables. Do not use the same containers and collection trays for "DEF" and other consumables. Do not use consumables containing traces of "DEF".

#### ⚠ DANGER

##### Risk of damage to components

The individual components of the DEF system react greatly even in the presence of the slightest trace of impurities in "DEF".

Use only clean containers and collection trays, suitable for containing "DEF". Do not use "DEF" containing traces of impurities.

#### ⚠ WARNING

##### Risk of poisoning

Fire-fighting measures: "DEF" is not flammable. In case of fire, NH<sub>3</sub> (ammonia) can be released. In this case there is the danger of poisoning. Fire-fighting measures must be suitable for the environmental conditions.

#### ⚠ DANGER

##### Environmental protection warning Disposal of "DEF":

A small amount of "DEF" accidentally spilled is not a problem. The product is easily biodegradable and can be dispersed without problems in the sewer system using a lot of water. For the disposal of larger quantities of "DEF", always comply with the requirements of the law on environmental protection and recycling / disposal of waste. Packages containing residues of "DEF" must be treated the same way as "DEF". Completely empty the contents of the packages; this way after cleaning the packages can be reused.

- Check the indicator on the display (DRIVE page).
- If necessary, add "DEF" fluid.
- Open the flap (1) by using the ignition key to see the "DEF" filler neck.
- Remove the cap (2).
- Fill the tank with fresh, uncontaminated "DEF" fluid, through the filler neck (3).
- Replace the cap (2).
- Look to make sure that there are no leaks on the tank or pipes.



Figure 149: Checking DEF liquid level

### 4.3.7 FUEL PRE-FILTER CHECK

**⚠ DANGER**

**Fire risk**

Smoking or approaching with an open flame is prohibited. The diesel engine must be turned off. Consult maintenance personnel if in doubt about the state of the water separator.

- Open the engine cover and locate the fuel pre-filter (1).
- Check that there is no water in the tank (2) and empty it if necessary.
- Place a container under the water separator to collect water and contaminants.
- Turn the fuel valve (3) to the CLOSED position (4).
- To drain the water, manually loosen the discharge valve (6) located in the lower part of the water separator bowl. If no water comes out, at the top of the filter holder turn the air vent screw (5) counterclockwise 2 to 3 turns to loosen it.
- If water still does not come out, open the fuel tap.
- After draining the water separator bowl, hand tighten the discharge valve (6).
- If the air vent screw (5) has been loosened, be sure to tighten it.
- Open the fuel valve (3) and prime the fuel following the "Priming the Fuel System" procedure. Check for fuel leaks.

- Close the engine cover.

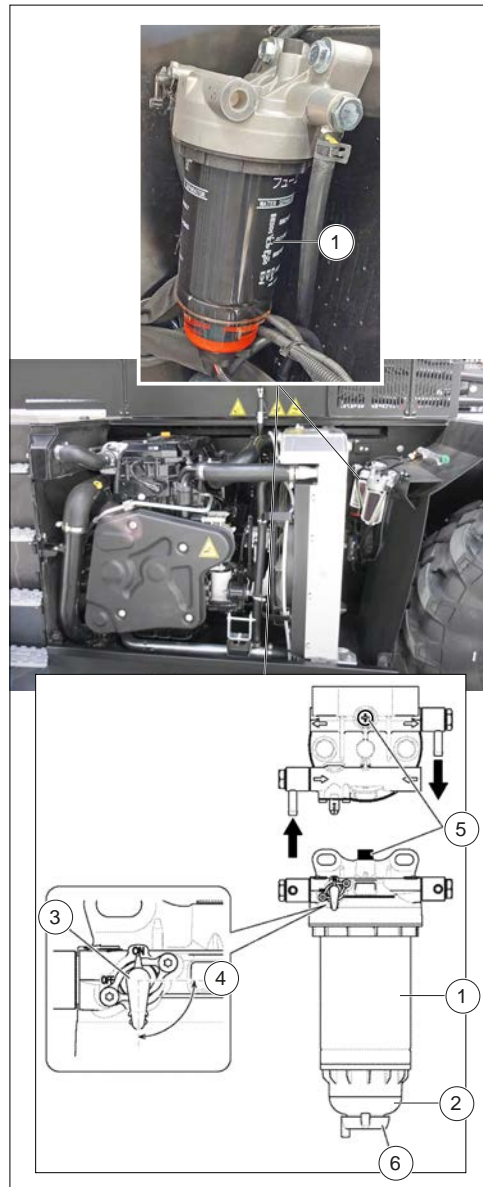

Figure 150: Fuel pre-filter check

### 4.3.8 CABIN GLASS INTEGRITY CHECK

**⚠ DANGER**

**Structural and/or superficial damage risk**

The use of cleaning materials incompatible with the cabin windows can cause structural and/or surface damage.

Do not use abrasive or highly alkaline cleaners on the cabin windows. Do not use aromatic or halogenated solvents such as toluene, benzene, gasoline, acetone or carbon tetrachloride on the cabin windows. If in doubt about the cleaning material, contact your agent or dealer.

## ⚠ DANGER

### Risk of surface degradation and cracking

Contact with aggressive solvents such as methyl ethyl ketone (MEK) or hydrochloric acid can cause surface degradation and possible cracking of the cabin windows.

Do not scrub with brushes, steel wool or other abrasive materials. Do not use spatulas, razor blades or other sharp tools to remove deposits or stains. Do not clean the cabin windows in direct sunlight or high temperatures as this may cause stains.

Cleaning and periodic inspection of the cabin windows, using correct procedures, is recommended for the safety of the operator and to prolong their service life.

- Thoroughly clean all windows in the cabin (windshield, rear window, upper window, side windows).
- Check the integrity of the windows on each side of the cabin.
- Check that there are no scratches, abrasions, cracks etc. In this case it is necessary to replace the glass.

**Contact your agent or dealer immediately.**

Here is how to clean the cabin windows in the best way and to keep them in good condition.

### CLEANING PROCEDURE WITH CLEANING EQUIPMENT

- Clean the surface using a high pressure cleaner (max. 100 bar or 1,450 psi) and/or a steam cleaner. We suggest testing a small area before cleaning the entire glass.
- Avoid the use of water and/or steam additives.

### MANUAL CLEANING PROCEDURE

- Gently wash the cloth with a mild soap and warm water solution, using a soft, non-abrasive cloth or sponge to remove dirt or grime.
  - Splashes of grease and soiled glass compounds can be removed easily before drying by wiping lightly with a soft cloth using petroleum ether (BP65), hexane or heptane.
  - Minor scratches and abrasions can be minimized by using a mild car polish cleaner. We suggest testing a small area of the glass with the selected cleaner (follow the instructions provided by the cleaner manufacturer).
- Contact your agent or dealer immediately.**
- Finally, rinse thoroughly with clean water to remove any detergent residue and dry the surface with a soft cloth to avoid water stains.

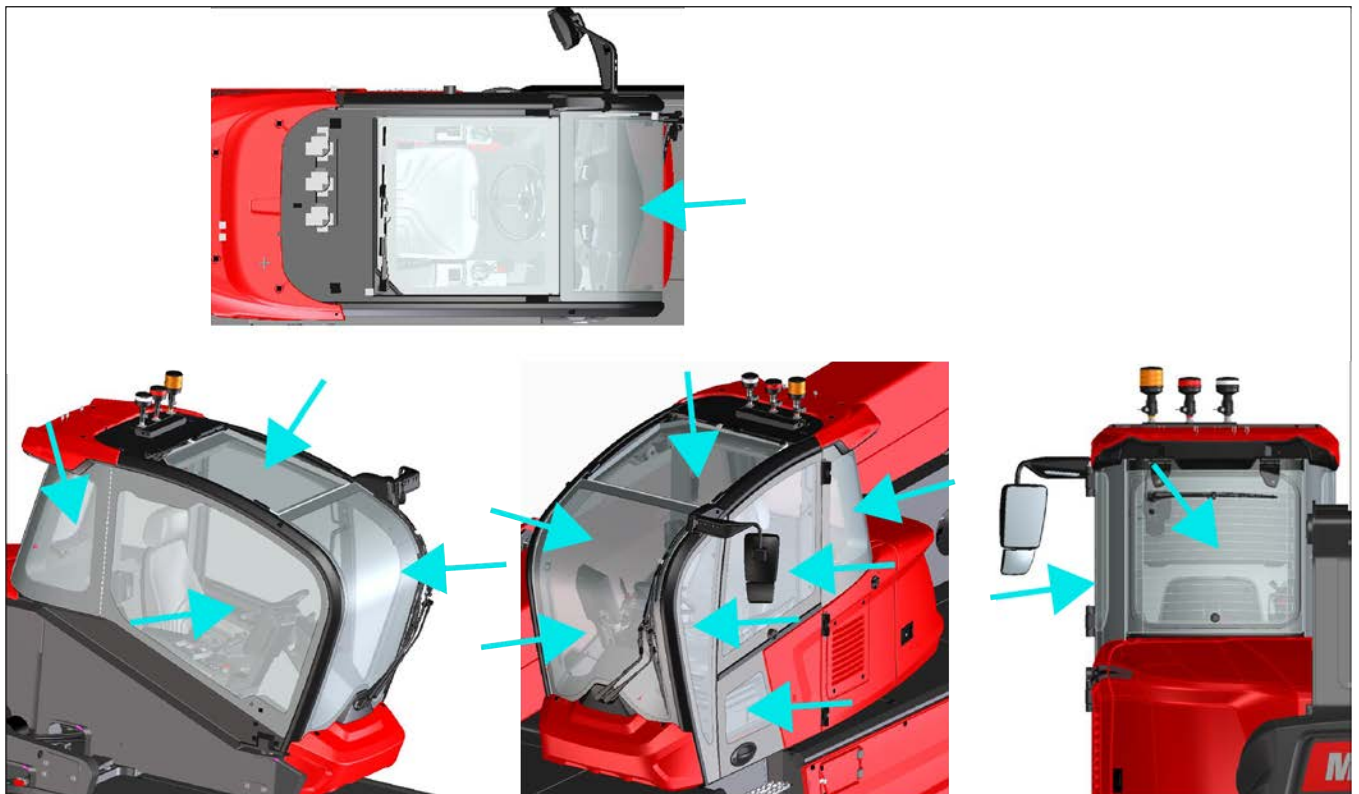

Figure 151: Cabin glass integrity check

### 4.3.9 CABIN UPPER ANTI-BREAKAGE GLASS INTEGRITY CHECK (OPTIONAL)

**⚠ DANGER**

If the cabin is equipped with the "upper anti-breakage glass (optional) (1)", periodic maintenance is essential to keep the glass anti-breakage qualities and high impact resistance performance effective, thus providing the operator with greater safety and protection against any intrusion.

**⚠ DANGER**

#### Structural and/or superficial damage risk

The use of cleaning materials incompatible with the cabin windows can cause structural and/or surface damage.

Do not use abrasive or highly alkaline cleaners on the cabin windows. Do not use aromatic or halogenated solvents such as toluene, benzene, gasoline, acetone or carbon tetrachloride on the cabin windows. If in doubt about the cleaning material, contact your agent or dealer.

**⚠ DANGER**

#### Surface degradation and glass cracking risk

Contact with aggressive solvents such as methyl ethyl ketone (MEK) or hydrochloric acid can cause surface degradation and possible cracking of the cabin windows.

Do not scrub with brushes, steel wool or other abrasive materials. Do not use spatulas, razor blades or other sharp tools to remove deposits or stains. Do not clean the cabin windows in direct sunlight or high temperatures as this may cause stains.

**⚠ DANGER**

Replace the glass (1) every 10 years.

Cleaning and periodic inspection of the cabin windows, using correct procedures, is recommended for the safety of the operator and to prolong their service life.

- Thoroughly clean all windows in the cabin (windshield, rear window, upper window, side windows).
- Check the integrity of the windows on each side of the cabin.
- Check that there are no scratches, abrasions, cracks etc. In this case it is necessary to replace the glass. **Contact your agent or dealer immediately.**

Here is how to clean the cabin windows in the best way and to keep them in good condition.

#### CLEANING PROCEDURE WITH CLEANING EQUIPMENT

- Clean the surface using a high pressure cleaner (max. 100 bar or 1,450 psi) and/or a steam cleaner. We suggest testing a small area before cleaning the entire glass.
- Avoid the use of water and/or steam additives.

#### MANUAL CLEANING PROCEDURE

- Gently wash the cloth with a mild soap and warm water solution, using a soft, non-abrasive cloth or sponge to remove dirt or grime.
- Splashes of grease and soiled glass compounds can be removed easily before drying by wiping lightly with a soft cloth using petroleum ether (BP65), hexane or heptane.
- Minor scratches and abrasions can be minimized by using a mild car polish cleaner. We suggest testing a small area of the glass with the selected cleaner (follow the instructions provided by the cleaner manufacturer). **Contact your agent or dealer immediately.**
- Finally, rinse thoroughly with clean water to remove any detergent residue and dry the surface with a soft cloth to avoid water stains.

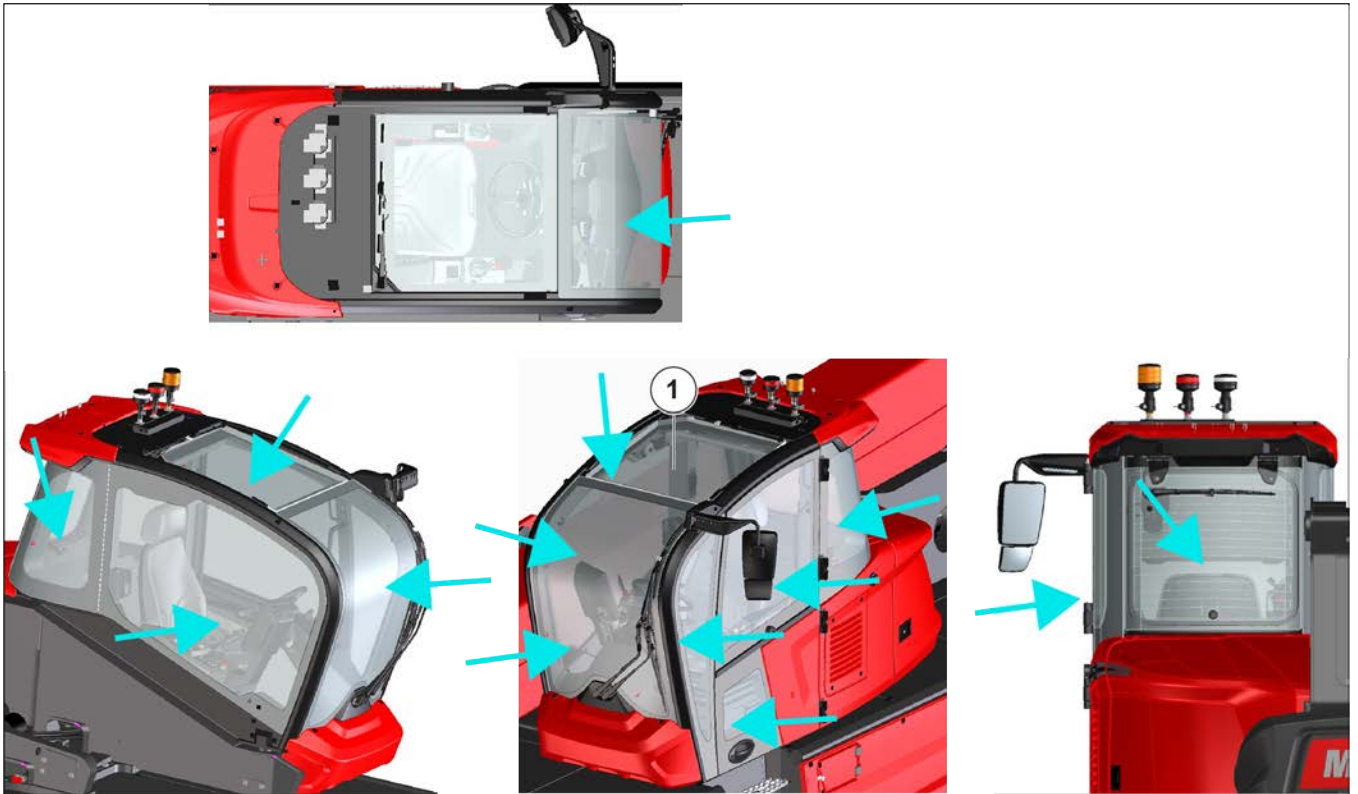

Figure 152: Cabin upper anti-breakage glass integrity check (optional)

## 4.4. EVERY 50 HOURS OF OPERATION

### 4.4.1 HYDRAULIC OIL LEVEL CHECK

Place the telehandler on a level surface with the engine off and the telescopic boom retracted and lowered as far as possible.

#### **⚠ DANGER**

Use a very clean funnel and clean the top of the oil can before filling.

- Remove the tank protection panel (1).
- By means of a visual check, make sure that there are no leaks or sweating.
- Refer to the optical indicator (2) on the tank to check the level which is correct when it is between the upper and lower marks.
- If necessary, add new oil from the filler neck (4). Remove the cap (3) from the filler neck (4) and top up with oil.

You must always keep the oil level at maximum.

- Refit the cap (3).

- Refit the tank protection panel (1).

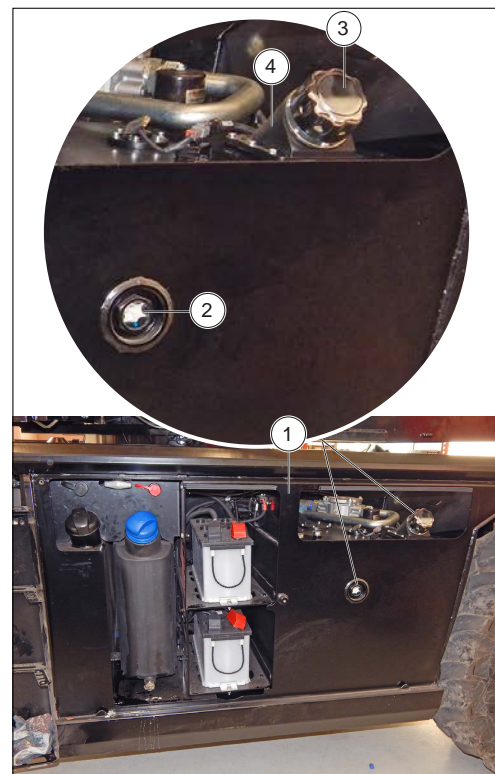

Figure 153: Hydraulic oil level check

### 4.4.2 TIRE PRESSURE AND WHEEL NUT TIGHTENING CHECK

**⚠ DANGER**

Check that the air tube is properly connected to the tire valve before starting the inflation and keep anyone away during the operations. Follow the recommended inflation pressures.

- Check the condition of the tires for cuts, bumps, wear, etc.
- Check the tightness of the wheel bolts. Failure to observe this warning could cause deterioration and breakage of the wheel pins, as well as deformation of the wheels themselves.
  - Front wheels: 680 Nm ± 15%.
  - Rear wheels: 680 Nm ± 15%
- Check and, if necessary, adjust the tire pressure (depending on the tire model equipped).

### 4.4.3 CLEANING THE RADIATOR GRILLE, HYDRAULIC OIL, COOLANT AND INTERCOOLER

**⚠ DANGER**

Adjust the frequency of cleaning according to the operating environment.

To access the coolant and air intercooler radiator, open the engine cover.

To access the hydraulic oil cooling radiator, remove the panel on the front frame (1).

Inspect these radiator elements: damaged fins, corrosion, dirt, grease, insects, leaves, oil and other debris.

Clean the radiator if necessary.

Compressed air is the best method for removing debris.

Direct the air jet in the direction opposite the fan air flow (1). Hold the nozzle approximately 6 mm (0.25 in) from the radiator fins.

Slowly move the air nozzle parallel to the radiator pipes. Pressurized air removes debris from between the pipes.

**⚠ WARNING**

#### Risk of injury

Air pressure can cause personal injury. Failure to comply with safety measures can cause personal injury.

When using compressed air, wear a face shield and protective clothing. The maximum pressure at the compressed air nozzle for cleaning must be less than 21 bar (30psi).

Pressurized water can also be used for cleaning. The maximum water pressure for cleaning must be less than 2.8 bar (40 psi).

Use pressurized water to soften the mud. Clean the core on both sides.

To remove oil and grease, use a degreaser and steam. Clean both sides of the core.

Wash the core with detergent and boiling water. Rinse thoroughly with clean water.

Once the radiator is cleaned, start the engine. Warm up the engine at idle speed with no load for 3-5 minutes. Bring the engine to maximum speed. Running at full throttle helps remove debris and dry the core. Reduce the engine speed to idle and then stop the engine. Use a lamp behind the core to see if it is clean. Repeat cleaning if necessary.

Check if the fins are damaged.

The folded fins can be opened with a “comb”.

Inspect these items to verify they are in good condition: welds, mounting brackets, air lines, connections, clamps and seals.

Make repairs if necessary.

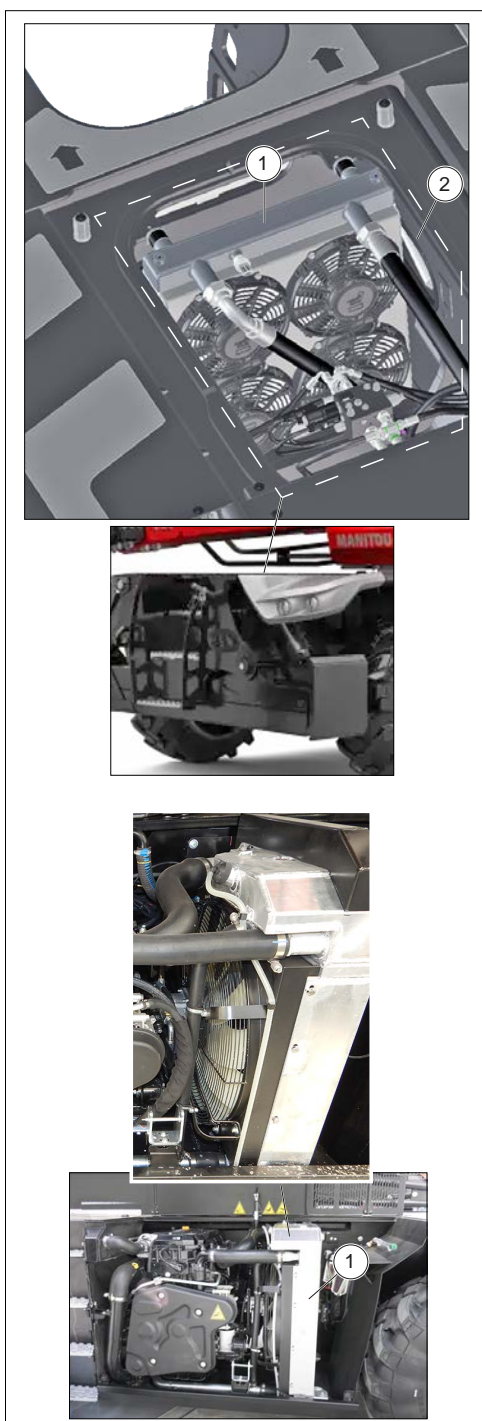

Figure 154: Cleaning the radiator grille, hydraulic oil, coolant and intercooler

#### 4.4.4 WINDSCREEN WASHER FLUID LEVEL CHECK

Open the cover (1) behind the cabin to access the windscreen washer fluid tank (2)

Visually check the tank level.

If necessary, add washer fluid from the filler neck (3).

To access the filler (3), remove the grille (5) on part of the hood behind the cabin.

Remove the filler cap (4).

Add windscreen washer fluid through the filler neck (3).

Replace the filler cap (4).

Refit the grille (5) and close the cover behind the cabin (1).

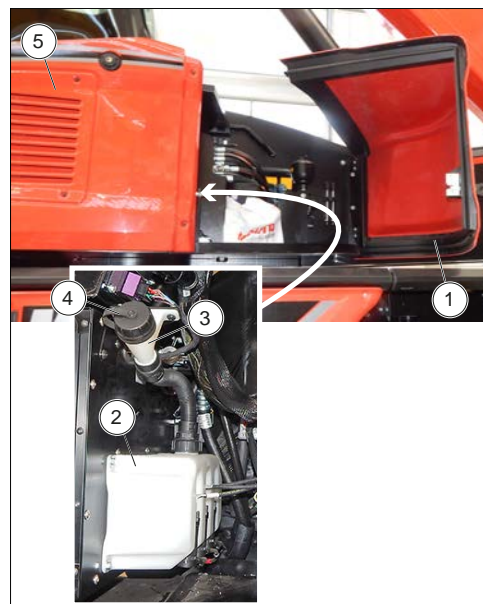

Figure 155:

#### 4.4.5 CHECKING AND CLEANING THE CONDENSER GRILLE (OPTIONAL AIR CONDITIONER)

### ⚠ DANGER

#### Risk of damage to the condenser fins

Do not use a jet of water or high pressure steam, this could damage the condenser fins.

In a polluting atmosphere, clean the radiator grille daily.

- Visually check whether the condenser (1) is clean. Clean if necessary.
- Clean the condenser with a jet of compressed air, directing it in the same direction as the air flow.

To optimize cleaning, carry out this operation with the fans on.

#### 4.4.6 GENERAL LUBRICATION

To be carried out every week if the telehandler has not reached 50 hours of weekly running.

**⚠ DANGER**

Raise the boom and place the safety wedge on the rod of the lifting cylinder.

In case of intense use in a very dusty or oxidizing atmosphere, reduce this frequency to 10 hours of operation or every day.

Clean, then lubricate the following points with grease and wipe off the excess.

**CLEANING AND LUBRICATION OF THE TELESCOPIC BOOM WEAR SHOES**

- Fully extend the telescopic boom.
- Clean the surface of the extension arms.
- Using a brush, apply a coat of grease to the 4 sides of the telescopic boom.
- Extend and retract the telescopic boom several times to distribute the grease evenly.
- Remove excess grease.



Figure 156: Cleaning and lubricating the telescopic boom wear shoes

**CARDAN JOINT LUBRICATION  
for machines MRT / MRT-X 2260 - 2660 - 2570 - 3060**

Lubricate the front and rear transmission shaft Cardan joint spiders (1) with grease.

**AXLE OSCILLATION LUBRICATION  
for machines MRT / MRT-X 2260 - 2660 - 2570 - 3060**

Lubricate the oscillation bushings of the front axle (2a) and rear axle (2b) with grease.

**FRONT AND REAR WHEEL REDUCER PINS  
LUBRICATION  
for machines MRT / MRT-X 2260 - 2660 - 2570 - 3060**

Lubricate the pins of the front and rear wheel reducers using the centralized lubricators (3).

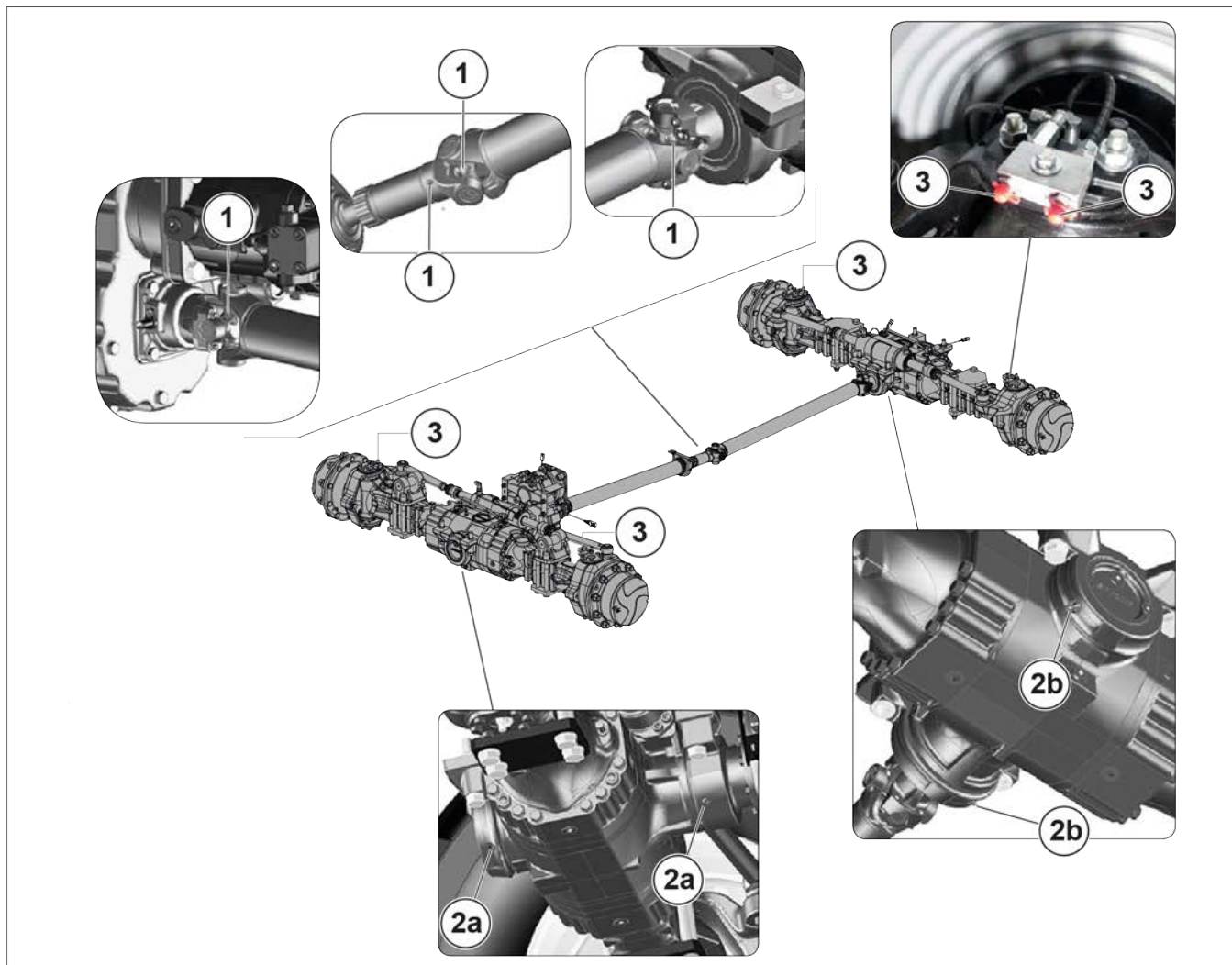

Figure 157: Cardan joint, axle oscillation and reducer pins lubrication

**CARDAN JOINT LUBRICATION  
for machines MRT / MRT-X 3570 - 3570 ES**

Lubricate the front and rear transmission shaft Cardan joint spiders (1) with grease.

**AXLE OSCILLATION LUBRICATION  
for machines MRT / MRT-X 3570**

Lubricate the oscillation bushings of the front axle (2a) and rear axle (2b) with grease.

**FRONT AND REAR WHEEL REDUCER PINS  
LUBRICATION  
for machines MRT / MRT-X 3570 - 3570 ES**

Lubricate the pins of the front and rear wheel reducers using the centralized lubricators (3).

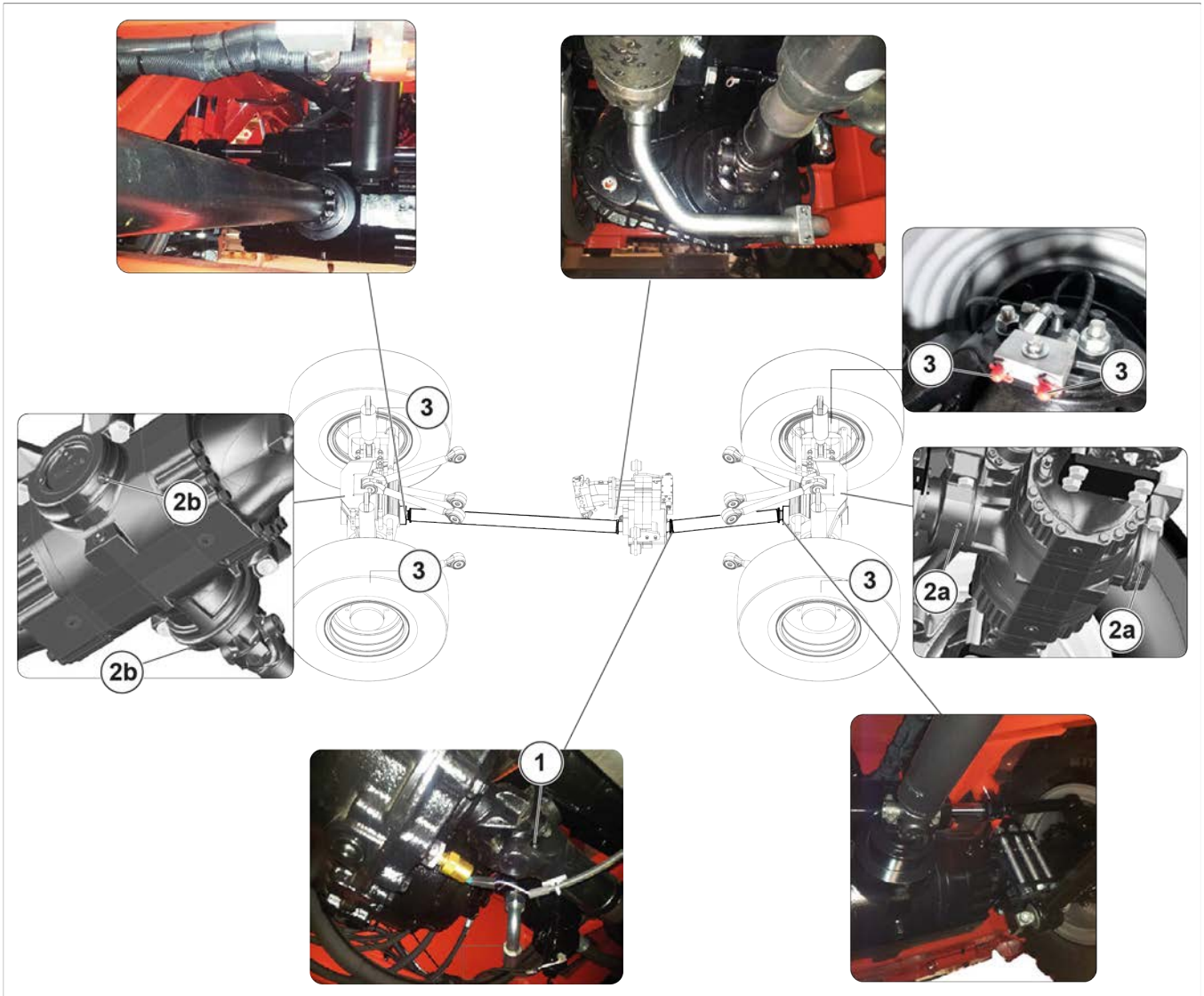

Figure 158: Cardan joint, axle oscillation and reducer pins lubrication

**CLEANING AND LUBRICATION OF THE FRONT AND REAR PINS OF THE STABILIZER FEET**

Stabilizer foot axle lubricators (1).

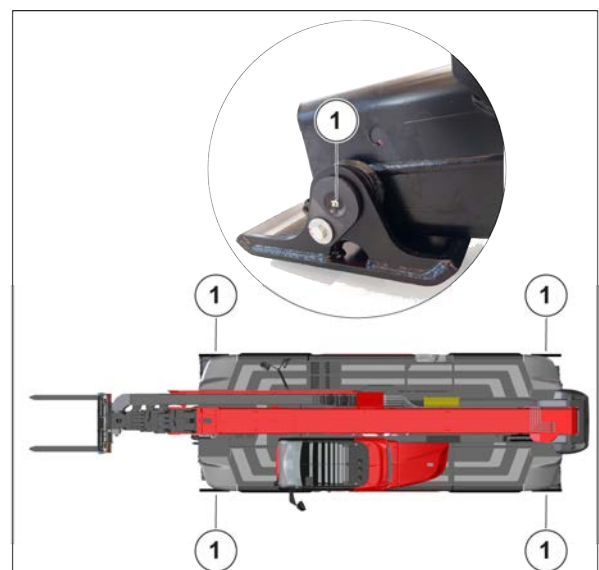

Figure 159: Cleaning and lubrication of the front and rear pins of the stabilizer feet

## CLEANING AND LUBRICATION OF THE TURRET ROTATION FIFTH WHEEL

### Turret rotation fifth wheel bearing lubricators

- Clean and lubricate the turret rotation fifth wheel.
  - Rolling system lubrication. The fifth wheel is externally equipped with grease nipples (1) for the lubrication of the rolling system. Clean the grease nipples and proceed with lubrication so that a film of fresh grease is seen coming out along the entire periphery of the labyrinths or from the protective seals.

### Toothing lubrication

- There must always be a film of grease on the toothing (2), lubricate manually with a brush.

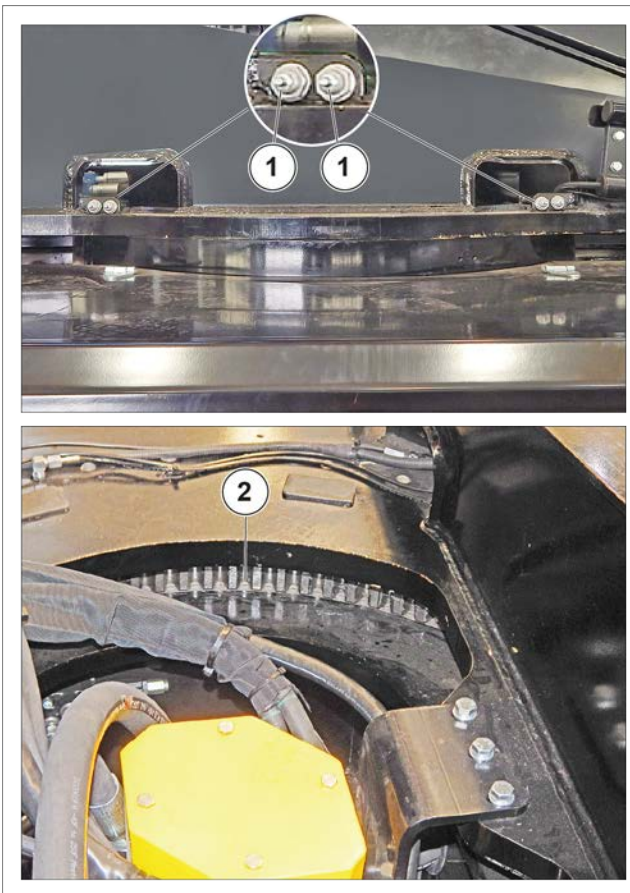

Figure 160: Cleaning and lubrication of the turret rotation fifth wheel

## 4.5. EVERY 250 HOURS OF OPERATION

### 4.5.1 FRONT AND REAR AXLE DIFFERENTIAL OIL LEVEL CHECK

Place the telehandler on a horizontal surface with the engine stopped.

Check the oil level of the front axle differential.

Remove the level plug (1) and top up (2), the oil must surface at the mouth of the hole.

If necessary, add fresh oil through the hole.

Repeat this for the rear axle differential.

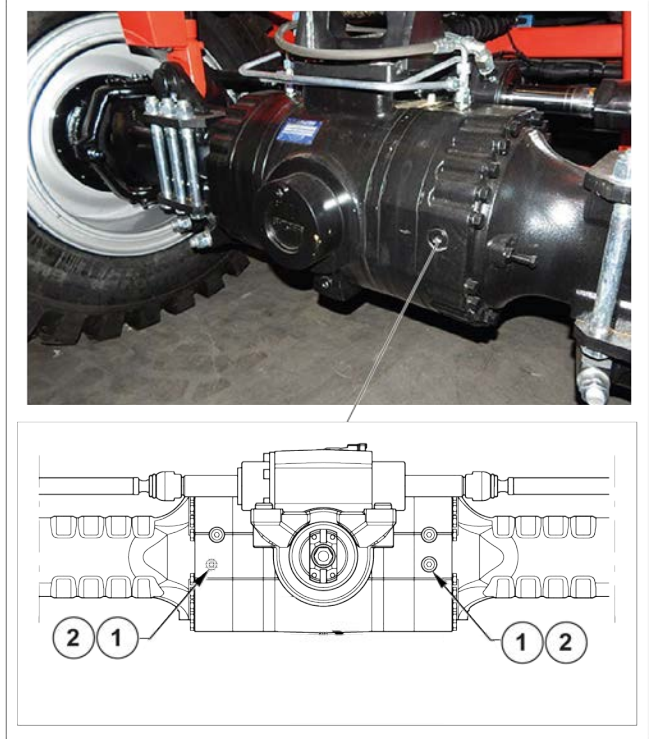

Figure 161: Front and rear axle differential oil level check

### 4.5.2 FRONT AND REAR WHEEL REDUCER OIL LEVEL CHECK

Place the telehandler on a horizontal surface with the engine stopped.

Check the oil level of the front axle differential.

Remove the level plug (1) and top up (2), the oil must surface at the mouth of the hole.

If necessary, add fresh oil through the hole.

Put back and tighten the level and filler cap (1).

Repeat this for the rear axle differential.

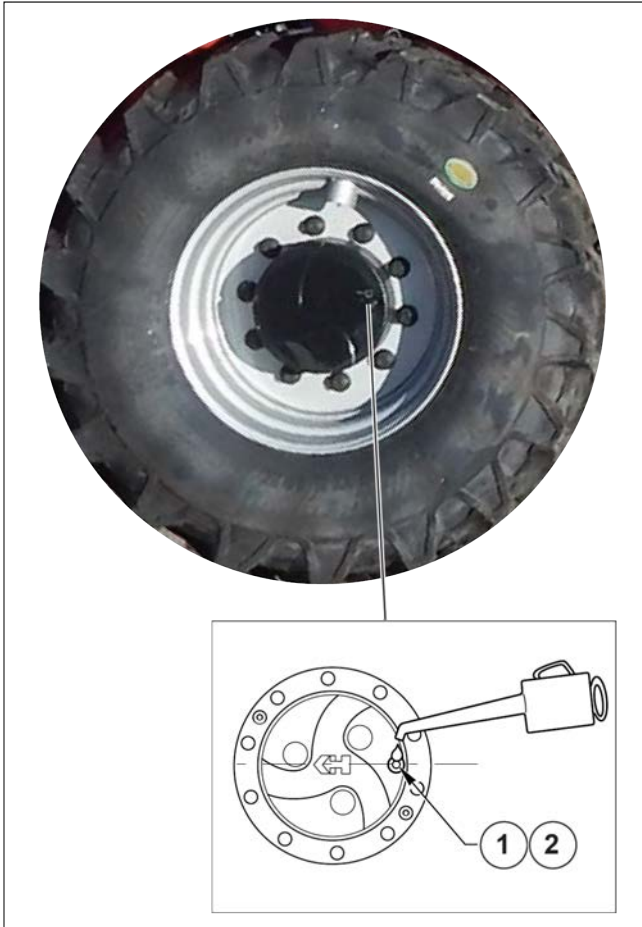

Figure 162: Front and rear wheel reducer oil level check

### 4.5.3 GEARBOX OIL LEVEL CHECK

(except MRT-X 3570, MRT-X 3570 ES)

Place the telehandler on a horizontal surface with the engine stopped and the gearbox oil still warm.

Remove the level and filler plug (1): the oil must rise to the surface of the hole.

Add fresh oil if necessary.

Put back and tighten the level and filler cap (1).

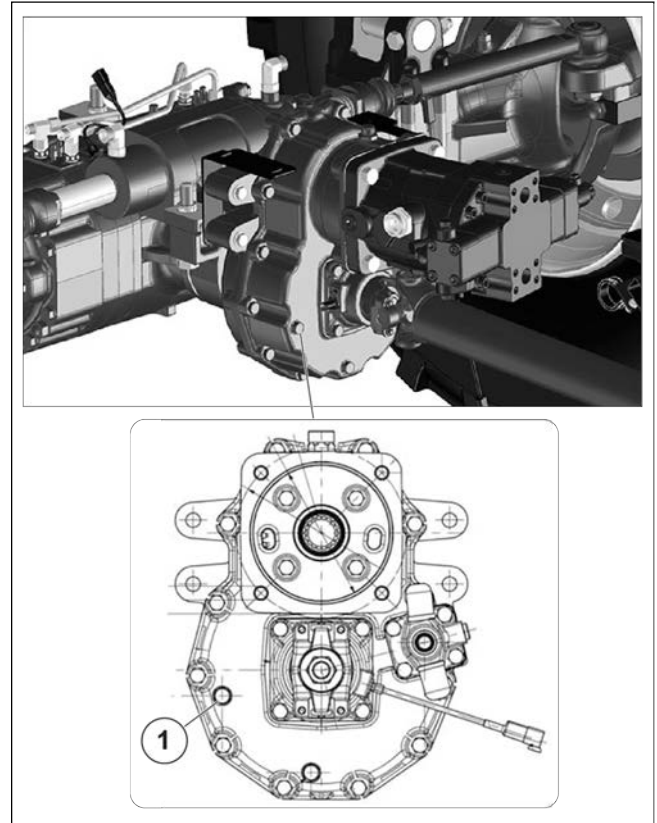

Figure 163: Gearbox oil level check

### 4.5.4 GEARBOX OIL LEVEL CHECK

**only for MRT 3570, MRT 3570 ES, MRT-X 3570, MRT-X 3570 ES**

Place the telehandler on a horizontal surface with the engine stopped and the gearbox oil still warm.

Check the oil level using the optical indicator (1). The oil level is correct when the optical indicator is full (1). If necessary, add fresh oil from the top up point (2).

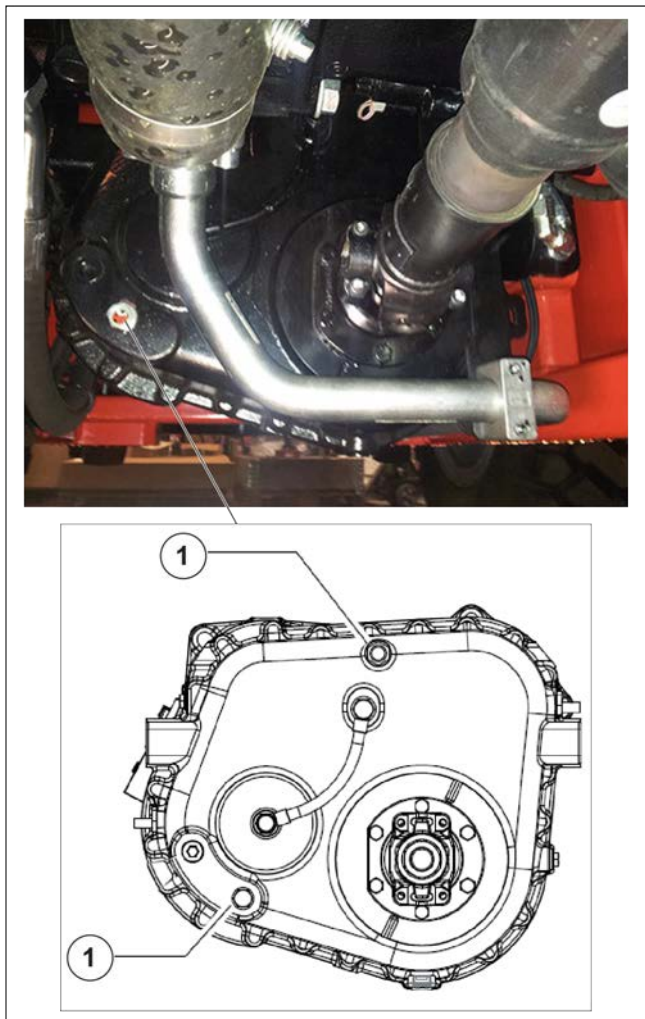

Figure 164: Gearbox oil level check

If the vehicle is not used for a long time, disconnect the battery.

In case of high ambient temperature, check the level more frequently.

**Maintenance:**

Open the engine cover (3).

Check the connection clamps (2).

Regularly check the electrolyte level (1) and, if necessary, top up with demineralized or distilled water. Never top up with sulfuric acid.

If the pole voltage of the battery is less than 12.3 V (electrolyte density <1.21), the battery must be recharged.

If the vehicle is not used for a long time, disconnect the battery.

**Charging the battery:**

- Remove the caps (1).
- The batteries should only be charged with direct current.
- Connect the positive (+) cable of the battery charger to the positive (+) pole of the battery and the negative (-) cable of the battery charger to the negative (-) pole of the battery.
- Recharge with a current equal to 1/10 of the nominal capacity (Ah) of the battery.
- The battery will be fully charged when the acid density is 1.28 (1.23, for tropical countries).
- After charging, turn off the charger before disconnecting the battery.
- Check the electrolyte level.

### 4.5.5 BATTERY CHECK

#### ⚠ WARNING

**Danger of corrosive substances**

Operate the battery switch at least 30 seconds after having cut off the electrical contact using the ignition key (1). Handling and maintaining a battery can be dangerous. Take the following precautions: Wear protective goggles. Handle the battery horizontally. Never smoke or work near a flame. Work in a sufficiently ventilated room. If the electrolyte comes into contact with the skin or eyes, rinse thoroughly with cold water for 15 minutes and consult a doctor.

Check the battery electrolyte level every 250 hours. When necessary, to restore the level add only distilled water. You should never add sulfuric acid. If frequent topping up of distilled water is required, or if the battery is subject to discharge, the voltage of the regulator must be checked, which must be between 13 V and 14.7 V, with the engine at maximum speed. Check from time to time that the connection terminals are not oxidized.



Figure 165: Battery check

#### 4.5.6 ROTATION REDUCER FIXING SCREW TIGHTENING CHECK

**⚠ DANGER**

Raise the boom and place the safety wedge on the rod of the lifting cylinder.

Place the forklift on a horizontal surface with the engine stopped and the telescopic boom completely raised.

Visually check the fastening of the rotation reducer screws (1) to the chassis and in case of anomalies tighten the bolts according to the torque values described:

Tightening torque 200 Nm / 20.3 kgf-m.



Figure 166: Rotation reducer fixing screw tightening check

#### 4.5.7 EXTERNAL BOOM CHAINS CHECK

**⚠ CAUTION**

These checks are important for the correct operation of the boom.

If there is any malfunction, consult your dealer.

##### Clean and lubricate

1. Place the telehandler on the stabilizers, with the boom horizontal.
2. Fully extend the telescopic booms.
3. Protect the upper part of the telescopic boom.
4. Wipe the external boom chains with a clean cloth

5. Examine the chains carefully for any signs of wear.
6. Brush the chains vigorously to get rid of any foreign bodies.
7. Use a nylon brush.
8. Then rinse the chains with a brush impregnated with new diesel oil and dry them with a jet of compressed air.
9. Moderately lubricate the chains, and carry out some telescopic movements to check the behavior of the chains.

#### Chain tension control

Check the tension of the upper boom chains and, if necessary, re-tension them using a special wrench.

1. Place the telehandler on the stabilizers, with the boom horizontal.
2. Fully extend the telescopic booms.
3. Make sure that the chains have remained under tension (keep the boom extraction lever pressed for a few seconds).
4. Measure the distance between the lower side of the chain and the boom (T1-T2-T3) with the aid of a gage or ruler.



Figure 167: MRT-X 2570, MRT-X 2570, MRT-X 3060, MRT-X 3060



Figure 168: MRT-X 2570, MRT-X 2570, MRT-X 3060, MRT-X 3060

Table 99. Chain registration value table

|                                |    |   | <b>MRT 2260<br/>MRT-X 2260</b> | <b>MRT 2660<br/>MRT-X 2660</b> |
|--------------------------------|----|---|--------------------------------|--------------------------------|
| <b>1st extension boom (T1)</b> |    |   | mm - in                        |                                |
| Minimum size                   | Y1 | ≥ | 87 - 3.4                       | 75 - 2.9                       |
| Maximum size                   | Y2 | ≤ | 117 - 4.6                      | 105 - 4,1                      |
| <b>2nd extension boom (T2)</b> |    |   | mm - in                        |                                |
| Minimum size                   | X1 | ≥ | 55 - 2,1                       | 45 - 1,7                       |
| Maximum size                   | X2 | ≤ | 85 - 3,3                       | 75 - 2,9                       |

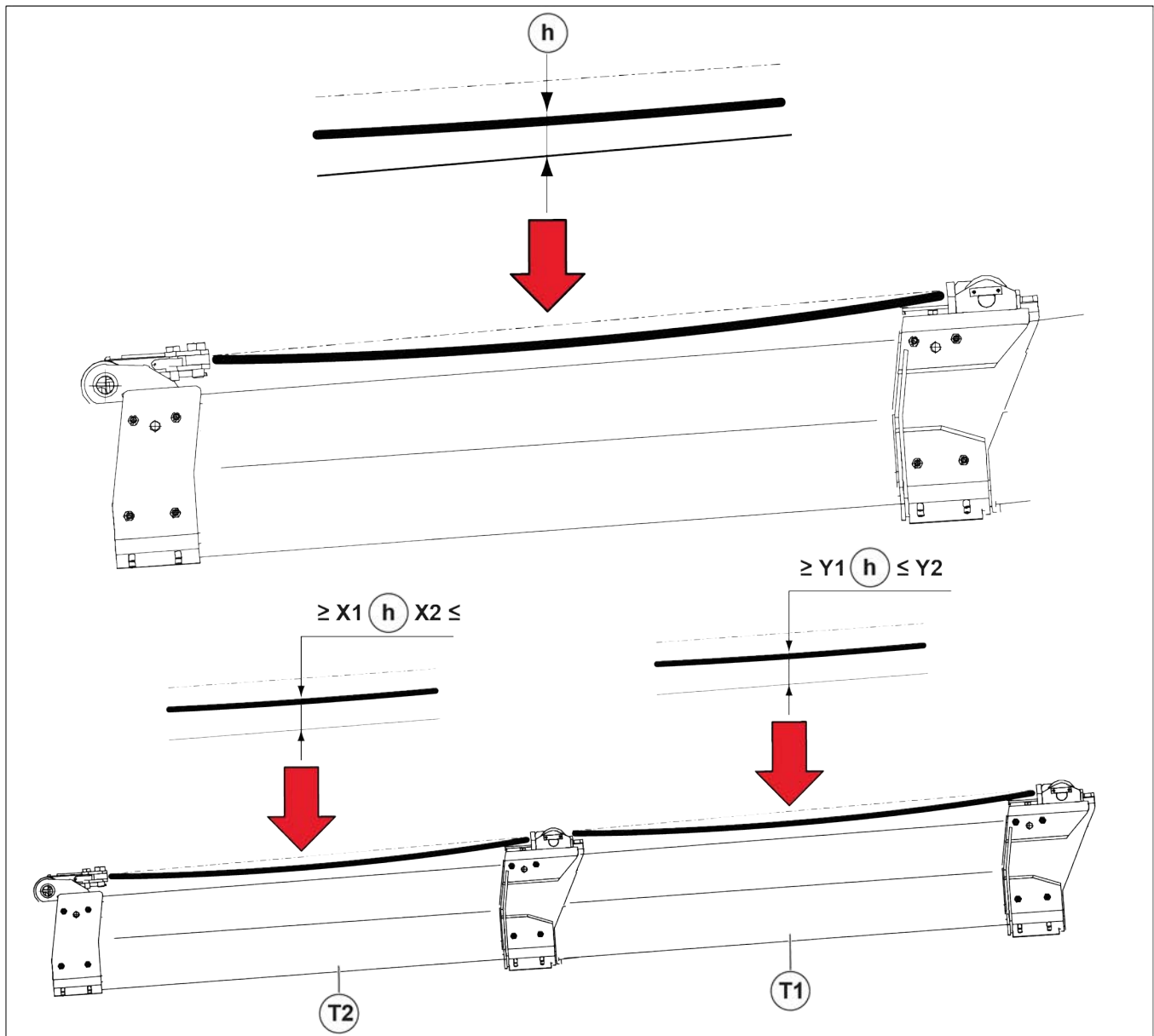

Figure 169: Chain tension control T1 - T2

Table 100. Chain registration value table

|                                |  | <b>MRT 2570<br/>MRT-X 2570</b> | <b>MRT 3060<br/>MRT-X 3060</b> | <b>MRT 3570<br/>MRT-X 3570</b> | <b>MRT 3570 ES<br/>MRT-X 3570 ES</b> |
|--------------------------------|--|--------------------------------|--------------------------------|--------------------------------|--------------------------------------|
| <b>1st extension boom (T1)</b> |  | mm - in                        |                                |                                |                                      |

|                                |    |        |           |
|--------------------------------|----|--------|-----------|
| Minimum size                   | Y1 | $\geq$ | 125 - 4,9 |
| Maximum size                   | Y2 | $\leq$ | 155 - 6,1 |
| <b>2nd extension boom (T2)</b> |    |        | mm - in   |
| Minimum size                   | X1 | $\geq$ | 105 - 4,1 |
| Maximum size                   | X2 | $\leq$ | 135 - 5,3 |
| <b>3rd extension boom (T3)</b> |    |        | mm - in   |
| Minimum size                   | Z1 | $\geq$ | 75 - 2,9  |
| Maximum size                   | Z2 | $\leq$ | 105 - 4,1 |

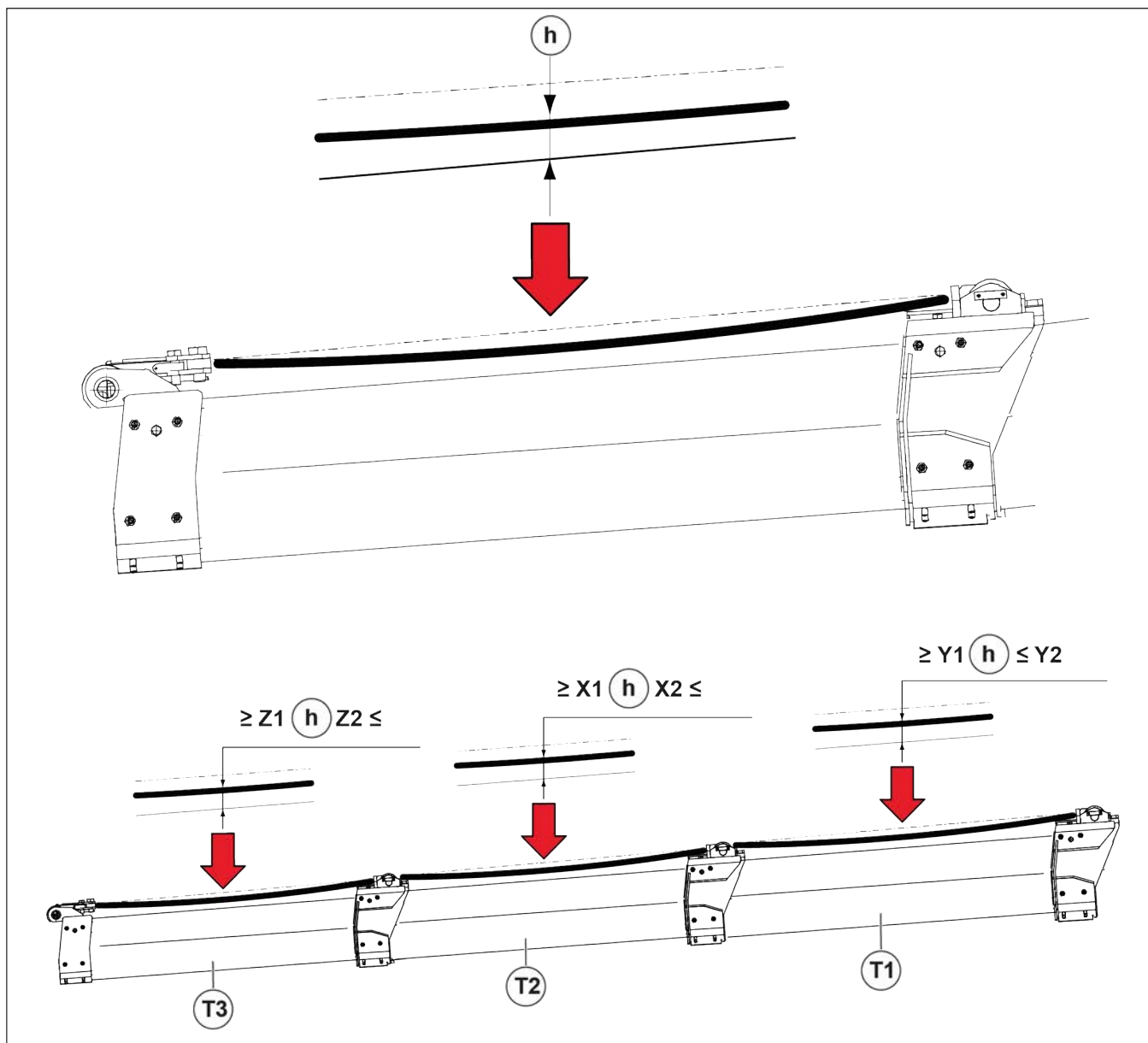

Figure 170: Chain tension control T1 - T2 - T3

### Registering the tension of the chains

Proceed to adjust the tension of the chains by acting with a special key on the tie rods on the boom (extension chains) (1).

If the play on the chains is excessive it may happen that the arm extensions do not retract completely.

Check and adjust if necessary the internal chain tie rods (2) for correct retraction of the extensions.

**⚠ CAUTION**

If the problem persists, consult your agent or dealer.

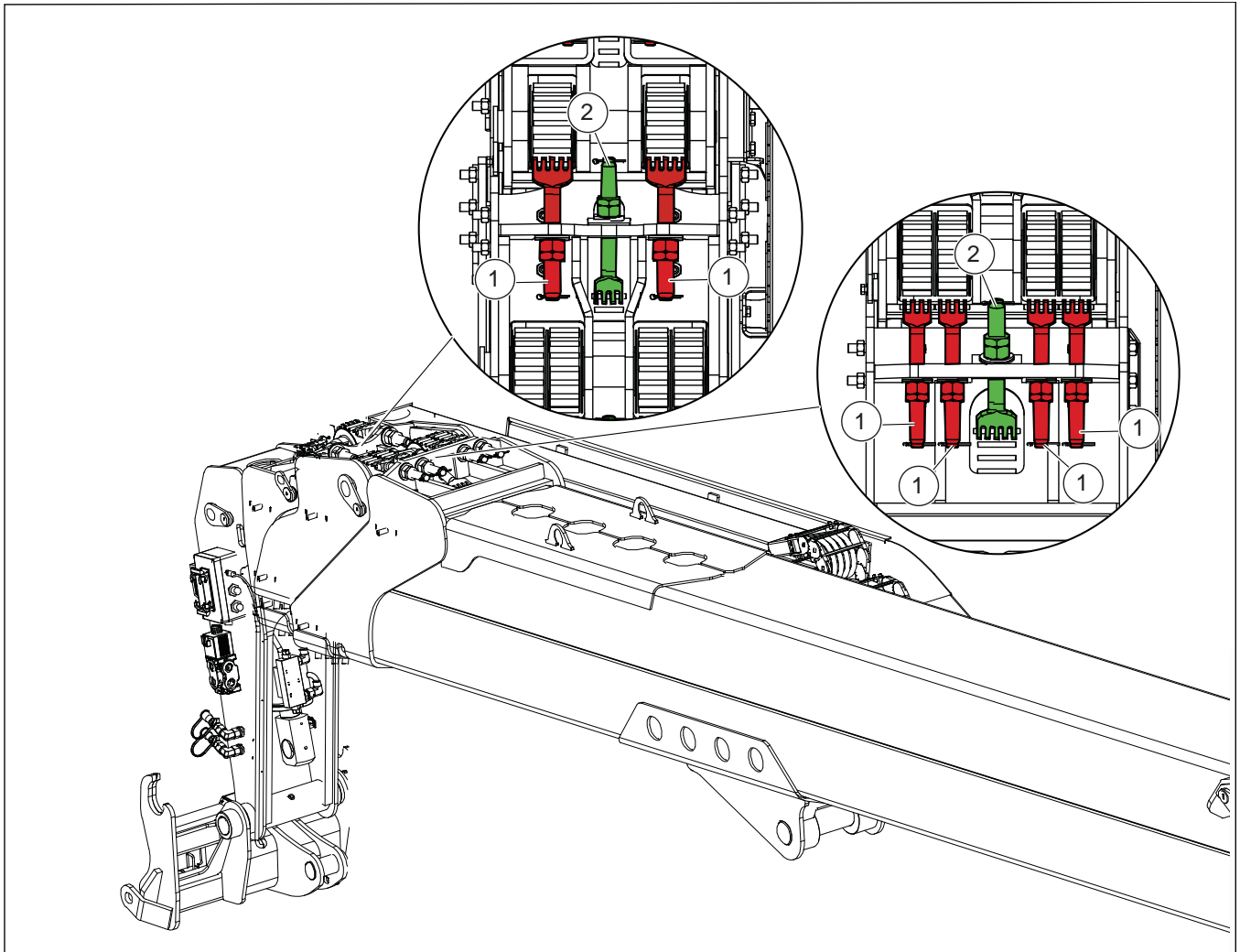

Figure 171: Adjustment of the tension of the chains T1 - T2

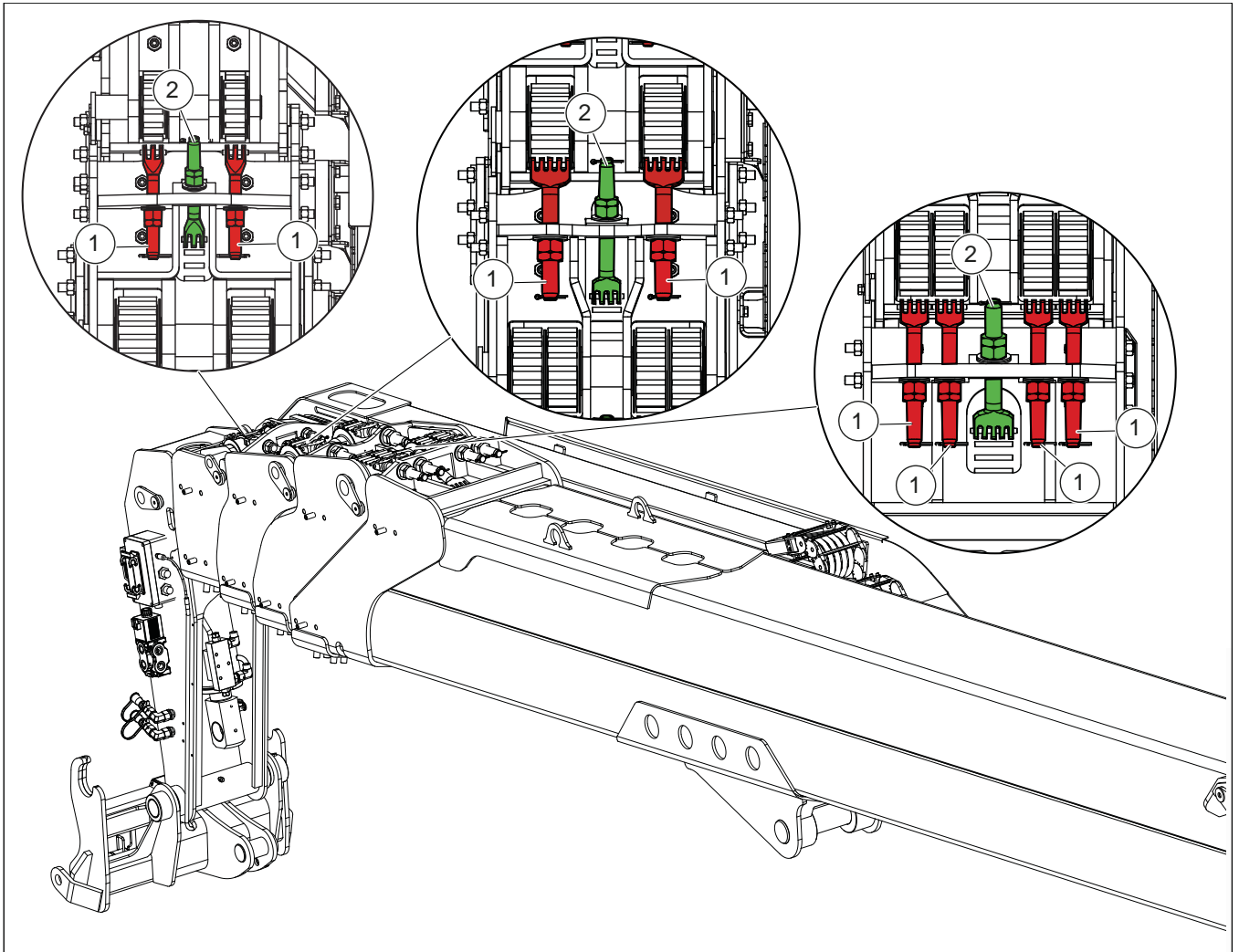

Figure 172: Adjustment of the tension of the chains T1 - T2 - T3

## 4.6. EVERY 500 HOURS OF OPERATION OR EVERY 6 MONTHS

### 4.6.1 HYDRAULIC OIL CONTAMINATION CHECK

MANITOU offers a hydraulic oil analysis kit that can allow you to extend the recommended period of periodic maintenance (2000 hours). In this case it is recommended to perform a hydraulic oil analysis every 500 hours of operation or 1 year.

The oil analysis kit also allows to validate the quality of the oil to reach the 2000 hour expiry in the case of specific uses that generate stress on the hydraulic circuit: extreme environmental conditions, use of attachments that require enormous hydraulic flow (sweeper, mixer).

- Order an oil analysis kit from your dealer.

- Once you have received the kit, take a sample and follow the recommendations indicated inside the kit itself.
- Keep the analysis report or change the hydraulic oil according to the results.

**Oil analysis kit (MANITOU reference: 958162).**



Figure 173: Hydraulic oil contamination check

### 4.6.2 REPLACING THE HYDROSTATIC PUMP OIL FILTER (TRANSMISSION)

#### ⚠ WARNING

##### Danger of intoxication and injury

Contact with hydraulic fluid is harmful to health (e.g. eye, skin and tissue damage, poisoning by inhalation).

While working with hazardous materials (for example, hydraulic fluids), always wear protective gloves and goggles.

Place the telehandler on a flat surface and stop the three-phase motor.

##### Replace the filter

To replace the filter cartridge and filter gasket:

- Loosen and remove the filter housing (4) from the filter head (1).
- Remove the used filter cartridge (3) from the filter housing (4).
- Check the filter head and filter housing for damage, wear and contaminants.
- Insert the new filter cartridge (3) into the filter housing (4).
- Check the O-ring and O-ring groove for damage, wear, or contaminants.
- Replace the O-Ring (2) with a new one. Lightly grease the O-ring.

- Screw the container filter (4) onto the filter head (1). Tighten the filter housing (4) with 45 Nm / 4.58 kgf-m.

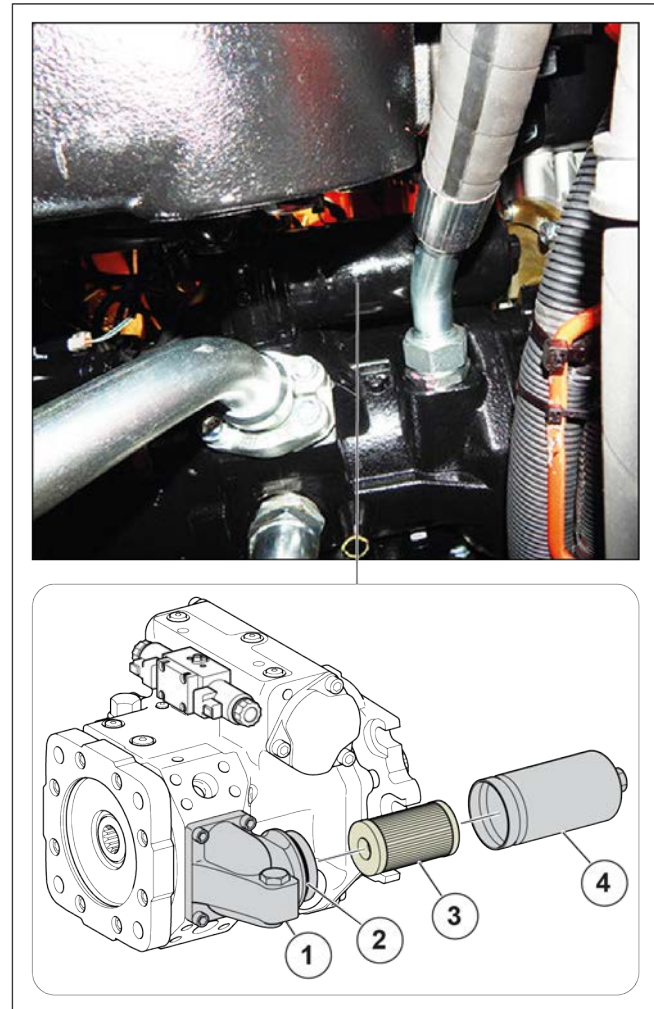

Figure 174: Replacing the hydrostatic pump oil filter (transmission)

### 4.6.3 REPLACING THE HYDRAULIC OIL FILTER CARTRIDGE (DRAIN)

- Remove the tank compartment top panel (1) to access the hydraulic oil drain filter cartridge.
- Loosen the 4 fixing screws (2) of the filter cover (3). Remove the used cartridge (4) and replace it with a new one with the same characteristics (4).
- Refit the filter cover (3) and tighten the 4 fixing screws (2).
- Refit the upper panel (1) of the fuel tank compartment.

#### ⚠ DANGER

Before screwing the filter cover (3) back on, check that the cartridge (4) is fitted correctly.

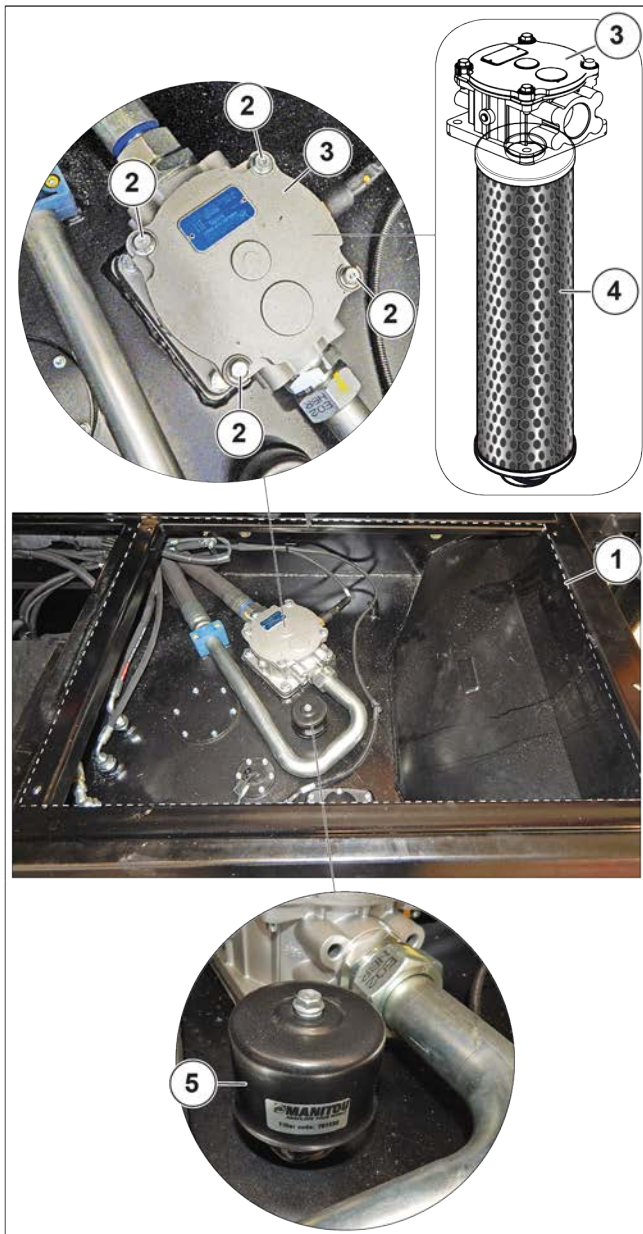

Figure 175: Replacing the hydraulic oil filter cartridge (drain)

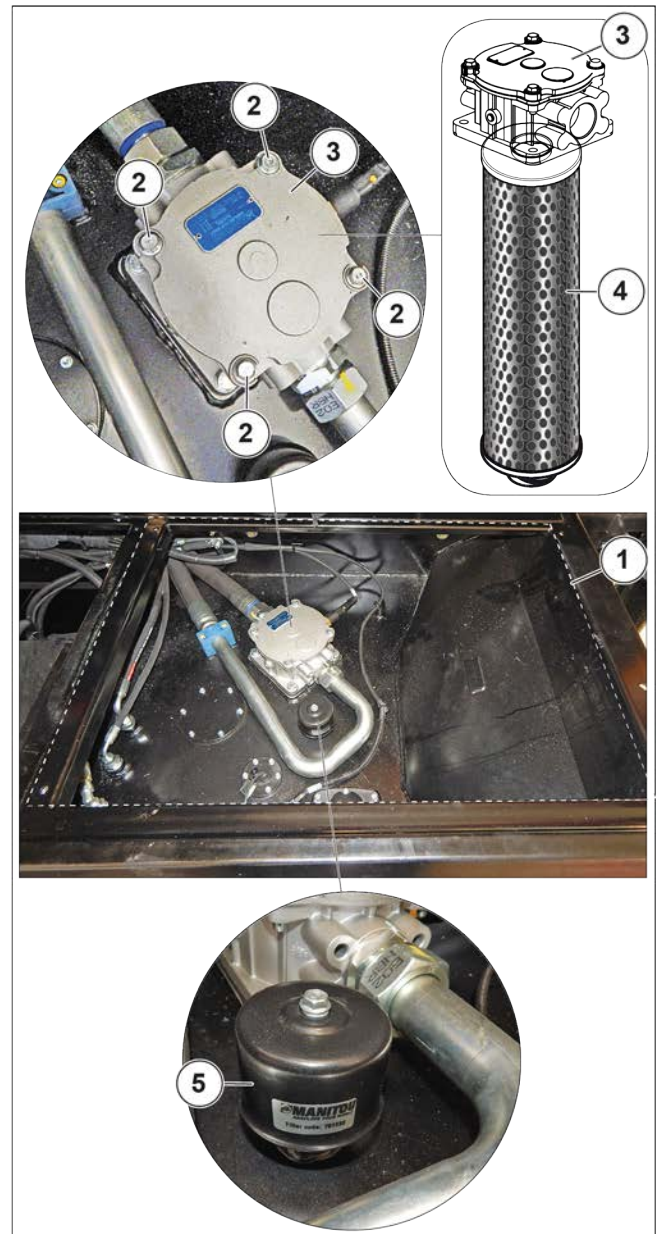

Figure 176: Replacing the hydraulic oil breather

#### 4.6.4 REPLACING THE HYDRAULIC OIL BREATHER

- Remove the upper panel (1) of the tank compartment to access the breather (2).
- Unscrew the breather (5) on the hydraulic oil tank and replace it with a new one with the same characteristics.
- Fit the new breather (5) tightening it by hand.
- Refit the upper panel (1) of the fuel tank compartment.

#### 4.6.5 FIFTH WHEEL AND TURRET FIXING BOLTS CHECK

### **⚠ DANGER**

Raise the telescopic boom and place the safety wedge on the rod of the lifting cylinder.

- Place the telehandler on a flat surface, without load and stress from external forces.
- Stop the three-phase motor.
- Visually check the correct tightening of the fifth wheel and turret bolts (2). In case of anomalies, tighten the bolts according to the tightening torque values: 450 Nm / 45.8 kgf.

To tighten the fifth wheel bolts (2) that secure it to the chassis, it is necessary to pass through the holes above the turret (1a). Remove the caps (1) to access the bolts (2).

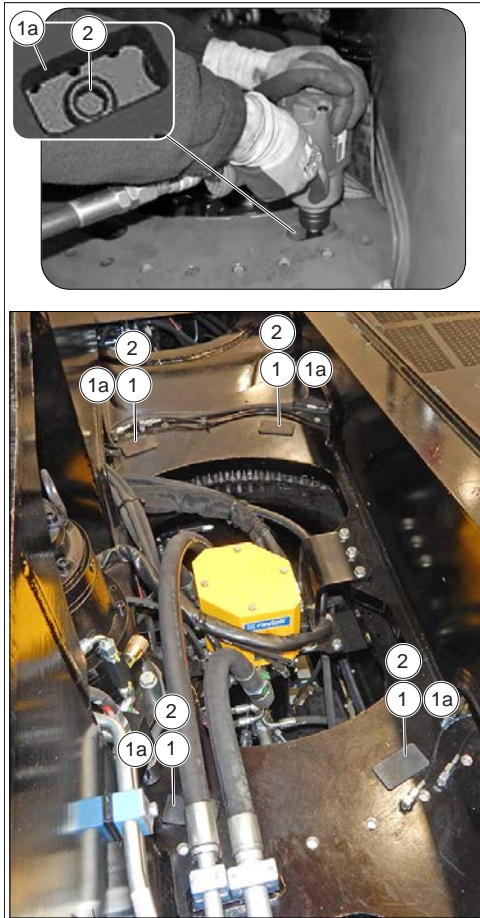

Figure 177: Fifth wheel and turret fixing bolts check

### 4.6.6 CABIN VENTILATION FILTERS CHECK

1. Stop the engine.
2. Remove the air intake (1) fixed on the cover behind the cabing to access the primary (2) and secondary (3) ventilation filters.
3. Remove the grille (4) that protects the filters (2 and 3) by unscrewing the knob (5).
4. Remove the primary filter (2).
5. Remove the secondary filter (3) by pulling it from the flap (3a).
6. Then clean the filters with a jet of compressed air.
7. Check the condition of each filter (2 and 3) and replace it if necessary.
8. Reposition the secondary filter (3) and then the primary filter (2) in its seat.
9. Refit the grille (4) that protects the filters (2 and 3) locking it by screwing the knob (5).
10. Refit and secure the air intake (1) on the cover behind the cabin.

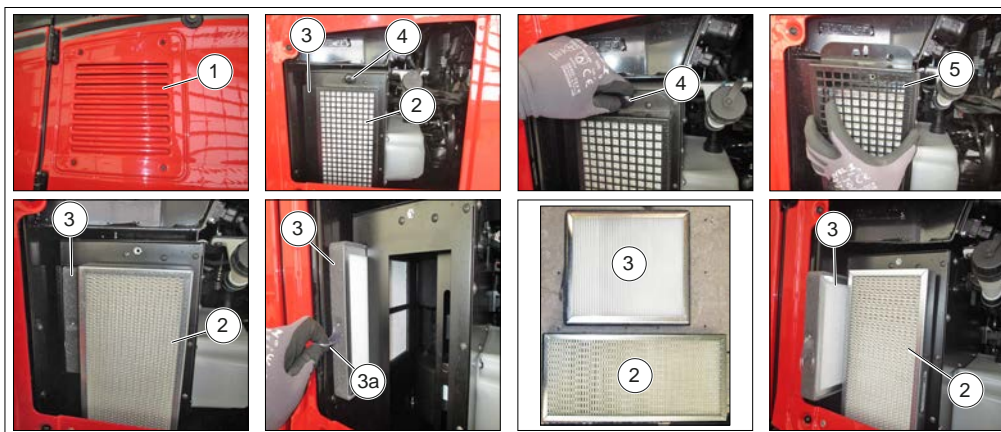

Figure 178: Cabin ventilation filters check

### 4.6.7 FORKS WEAR CHECK

Contact your dealer.

## 4.7. EVERY 1000 HOURS OF OPERATION OR EVERY YEAR

### 4.7.1 FILTER AND THREE-PHASE MOTOR OIL CHANGE

#### ⚠ WARNING

##### High temperature risk

Change the oil only with the engine at operating temperature. Place the telehandler on a level surface.

#### DRAIN THE ENGINE OIL

#### ⚠ DANGER

Dispose of the engine oil and filter in accordance with the legal regulations in force in the place where the engine is used.

- Open the engine cover.
- Remove the lower crankcase (1) from the engine compartment.
- Place a suitable collection container (6) under the drain screw (2) on the underside of the oil pan. Carefully unscrew the drain plug (2) and drain the oil from the hole (2a).
- Remove the filler cap (3) to make it easier to drain the oil.
- Screw the drain screw (2) back with a new sealing ring and tighten it:
  - Tightening torque: (39.8 - 47.0 ft-lb) (53.9 - 63.7 Nm, 5.5 - 6.5 kgf-m).
- Properly dispose of used oil.

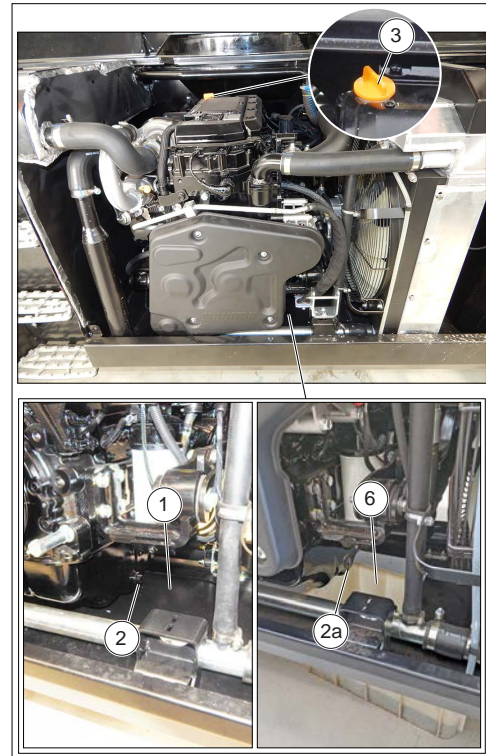

Figure 179: Engine oil drain

#### REPLACE THE ENGINE OIL FILTER

After draining the engine oil:

- remove the engine oil filter (1) by turning it counterclockwise (2) using a filter wrench.
- To install the new engine oil filter:
  1. Clean the mounting surface of the bracket (3) of the engine oil filter;
  2. Lightly apply clean engine oil to the gasket surface of the new oil filter. Manually install the new engine oil filter (4) by turning it clockwise (5) until it contacts the mounting surface. Tighten to the prescribed torque (21.0 - 25.0 N m) (2.2 - 2.6 kgf-m) or one more turn using the filter wrench.

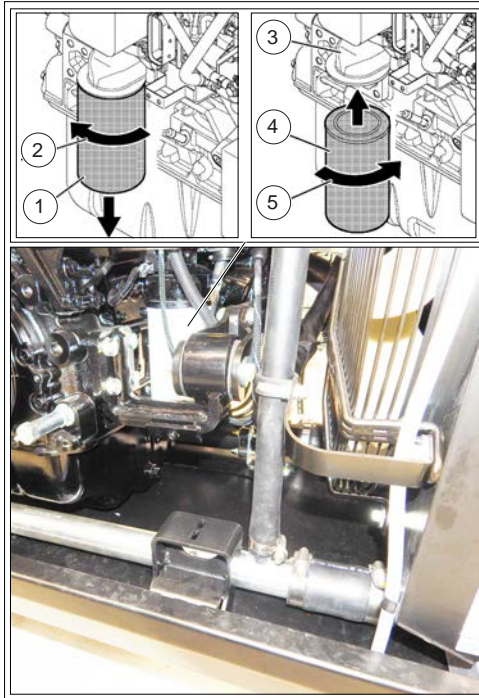

Figure 180: Engine oil filter replacement

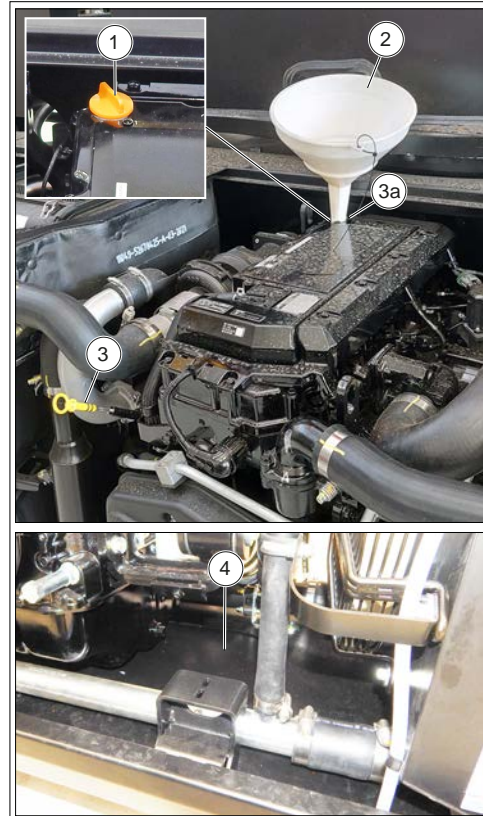

Figure 181: Filling with engine oil

### FILLING WITH ENGINE OIL

- Remove the engine oil filler cap (1).
- From the filler neck (3a), through a funnel (2) add the indicated quantity of lubricating oil. When loading oil into the engine, add it gradually. As a guideline, add no more than 1.2 L - 0.26 US gal of oil at a time, at intervals of 30 seconds or more. If oil is added all at once, the lubricating oil could enter the crankcase and combustion chambers with the risk of consequent engine damage.
- Run the engine for five minutes to warm it up and check for lubricating oil leaks.
- When the engine is warm enough, turn it off and let it sit for ten minutes.
- Check the lubricating oil level (3).
- If necessary, add more engine oil until the level is between the upper and lower lines on the dipstick (2).
- Refit the lower engine compartment cover (4).

### 4.7.2 FRONT AND REAR AXLE DIFFERENTIAL OIL CHANGE

Place the telehandler on a level surface with the engine stopped and the differential oil still warm.

- Place a container under the drain plug (1) and let the oil drain out.
  - Remove the level and filler plug (2) to ensure complete emptying.
  - Fit and tighten the cap (1). Fill the oil through the filling hole (2).
  - The level is correct when the oil emerges from the level hole (2).
  - Check for leaks from the drain plugs (1).
  - Fit and tighten the level and filler plug (2).
- Do the same for the front and rear differential.

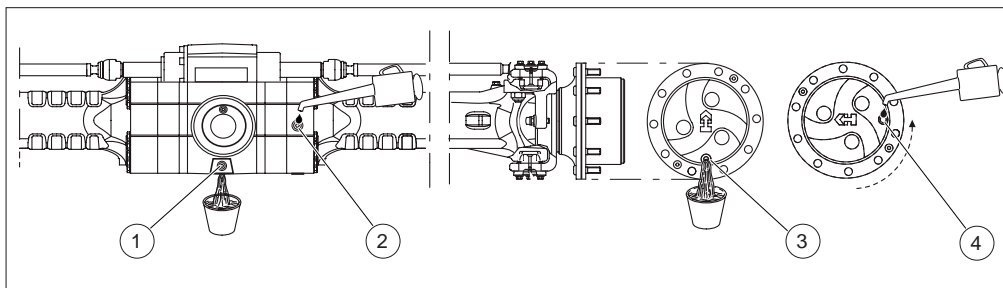

Figure 182: Front and rear axle differential oil change

### 4.7.3 CHANGE FRONT AND REAR AXLE FINAL REDUCER OIL

Place the telehandler on a flat surface with the engine stopped and the gearbox oil still warm.

- Make sure that the drain and level plug (3) of the reducer is oriented downwards to allow the oil to drain better.
- Place a container under the drain plug (3) and unscrew it. Let all the oil drain out. Bring the outlet hole to a horizontal position (4) in order to subsequently check the oil level.
- Refill with new oil through the level hole (4). The level is correct when the oil emerges from the hole (4).
- Replace the drain plug 3 and tighten it. Repeat this for each final drive.

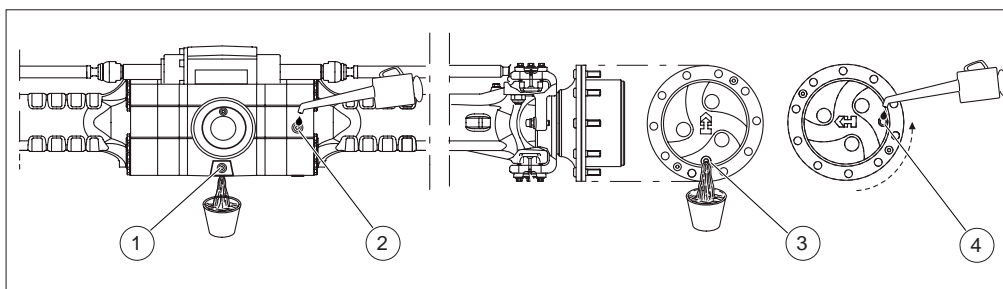

Figure 183: Change front and rear axle final reducer oil

### 4.7.4 GEARBOX OIL CHANGE

Place the telehandler on a level surface with the engine stopped and the gearbox oil still warm.

- Place a container under the drain plug (1).
- Remove the drain plug (1) and let the oil drain out.
- Remove the level and filler plug (2) to ensure complete emptying. Put back and tighten the cap (1).
- Fill with new oil through the level and fill hole (2). The level is correct when the oil comes out of the hole.
- Put back and tighten the level and filler plug (2). Check for any leaks from the drain plug.

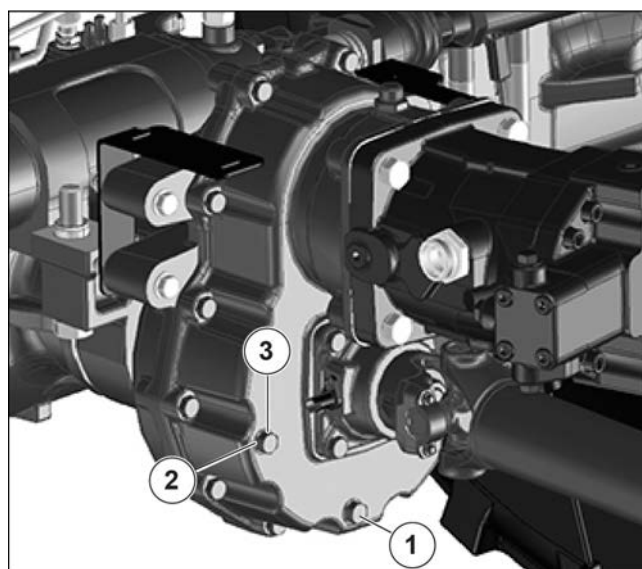

Figure 184: Gearbox oil change

### 4.7.5 GEARBOX OIL CHANGE AND SPEED SENSOR CLEANING

**only for MRT-X 3570, MRT-X 3570 ES**

Place the telehandler on a level surface with the engine stopped and the gearbox oil still warm.

**Oil drain**

- Place a container under the drain plug (1).
- Unscrew the drain plug (1) and let the oil drain out.
- Remove the filler cap (2) to ensure complete emptying.
- Refit and tighten the drain plug (1).

**Clean the speed sensor (4)**

- Loosen the screw and remove the speed sensor (4a).

- Loosen the screw and remove the speed sensor (4b).
- Install the speed sensor, and tighten the screw (4c) with a torque of (9.5 - 11 Nm / 1 kgf-m - 1.2 kgf-m).
- Install the speed sensor, and tighten the screw (4d) with a torque of (9.5 - 11 Nm / 1 kgf-m - 1.2 kgf-m).

**Oil filling**

- Fill the gearbox pan with new hydraulic oil and with the correct amount of oil through the filling hole (2a).
- Refit the filler cap (2).
- When the oil temperature is hot, check the oil level and top up if necessary.
- The oil level is correct when the visual indicator is full (3).
- Check for leaks from the drain plug (1).

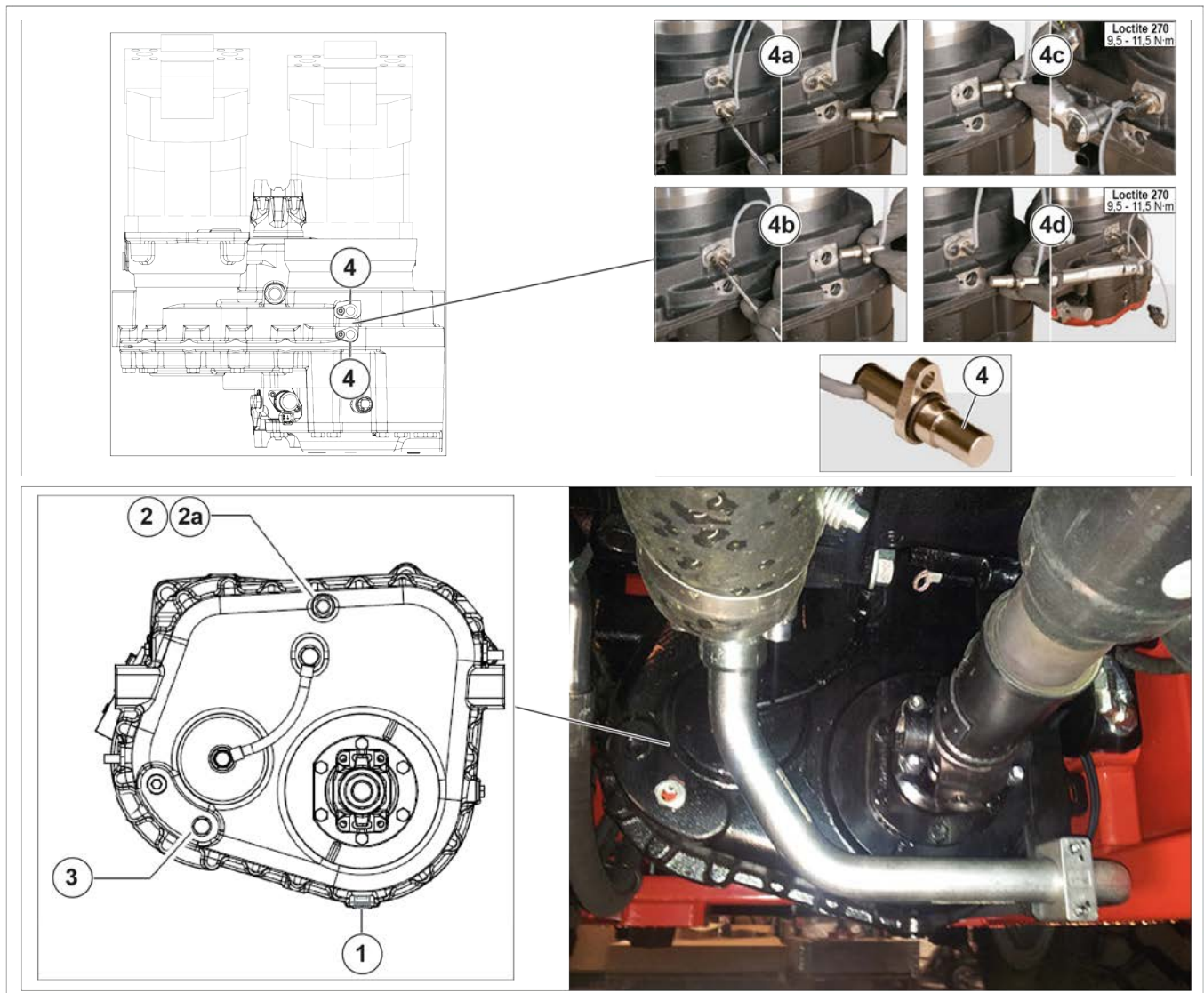

Figure 185: Gearbox oil change and speed sensor cleaning

### 4.7.6 DRY AIR FILTER CARTRIDGE REPLACEMENT

In case of use in a very dusty atmosphere, the cartridge replacement intervals must be reduced (up to 250 hours in a very dusty atmosphere).

#### **⚠ DANGER**

Replace the cartridge in a clean environment and with the heat engine off. Never use the telehandler with a disassembled or damaged cartridge. If the air filter service



indicator comes on , replace the cartridge as soon as possible (maximum 1 hour). Never use the telehandler without the air filter, or with a damaged air filter.

- To access the engine air filter box (5), lift the panel (6) above the ladder on the engine hood side, unscrewing the screws that secure it.
- Release the blocks and remove the cover (1).
- Carefully rotate the cartridge (2) forward to minimize dust escaping.
- Remove the cartridge (3).
- Do not remove the safety cartridge.
- Carefully clean the following parts with a damp, clean, lint-free cloth.
  - The inside of the filter and lid.
  - The inside of the filter inlet pipe.
  - The seats of the gaskets in the filter and in the cover.
- Check the condition and fastening of the connecting pipes to the heat engine, and the connection and conditions of the filter clogging indicator.
- Before assembly, check the condition of the new filter cartridge (4).
- Tilt the cartridge about 5° forward, insert it into the filter and position it by pressing on the edge of the cartridge and not in the center.
- Refit the cover and check the correct locking of the clips. The cover must be installed without difficulty, otherwise check the correct positioning of the cartridges in the filter.

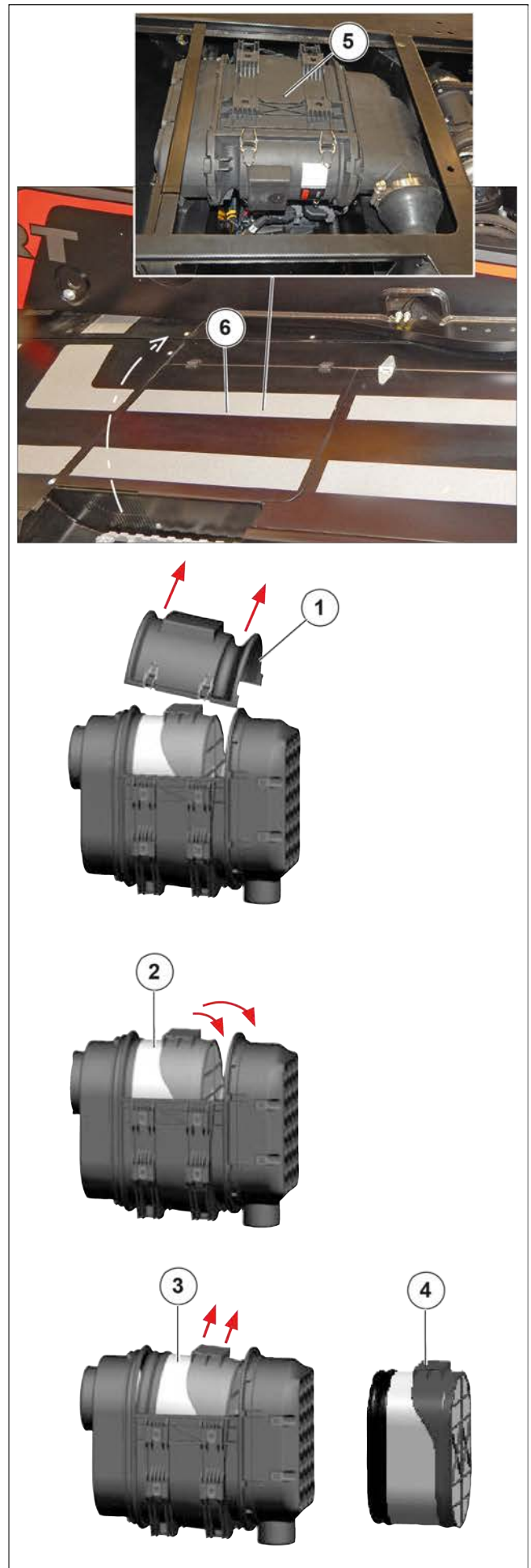

Figure 186: Dry air filter cartridge replacement 9649260EN-USMG(A/2021)

### 4.7.7 CLEANING THE FUEL TANK

**⚠ DANGER**

Fuels are highly flammable, so the risk of fire is high. During the handling of fuels, it is forbidden to smoke, approach naked flames and unprotected light and carry out interventions that cause the formation of sparks.

- Place the telehandler on a horizontal surface, lower the stabilizers as far as possible to increase the ground clearance of the machine.
- Stop the three-phase motor.
- Turn the ignition key to position "0".
- Close the water separator fuel valve.
- Open the access door (1) to the diesel filler neck (3).
- Unscrew the tank filler cap (2) then place a suitable container under the drain plug (4) and unscrew the cap.
- Let the fuel flow out of the hole (5) and pour 10 liters of clean fuel through the filler neck (3) to eliminate any impurities.
- Refit and tighten the drain plug (4).
- Fill the tank with clean fuel and replace the fill cap (2).
- Open the water separator fuel valve.
- Prime the fuel system.

**⚠ DANGER**

Do not fill the tank completely. As it warms up, the fuel expands. It could overflow from the tank.

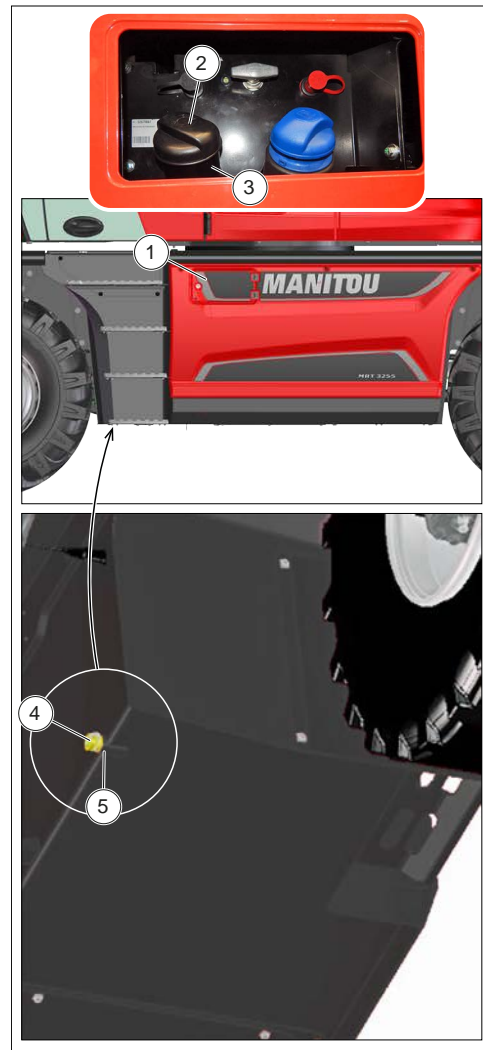

Figure 187: Cleaning the fuel tank

### 4.7.8 FUEL PRE-FILTER REPLACEMENT

**⚠ DANGER**

Thoroughly clean the outside of the pre-filter as well as its holder to prevent dust from entering the system. Tighten the fuel pre-filter by hand only and lock it a quarter of a turn.

- Place the telehandler on a horizontal surface and stop the heat engine.
- Turn the ignition key to position "0".
- Open the engine cover and locate the fuel pre-filter (14).
- Place a container under the water separator to collect the drained water and contaminants.
- Turn the fuel valve (1) to the (2) CLOSED position.
- Loosen the drain valve (3) to drain the fuel and contaminants.

- Turn the water collection cup (4) counterclockwise (5) and remove the filter element (6). Disconnect the drain pan sensor lead before removing it, being careful not to spill fuel.
- Clean up immediately if fuel is spilled.
- Remove the float (7) from the water collection pan. Pour the contaminants into the container and dispose of properly.
- By hand or using a pliers type filter wrench, turn the filter element counterclockwise (8) to remove it from the bracket (9). When using a filter removal wrench, apply it to the resin part (10) on the filter element.
- Clean the inside of the water pan with new diesel fuel.
- Replace the o-ring of the water collection pan with a new one.
- Clean the mounting surface of the bracket filter element and apply a thin layer of diesel fuel to the gasket surface of the new filter element.
- Install a new filter element onto the bracket and tighten it clockwise (11) hand tight. Do not use any tools.
- Install a new O-Ring (12) on the water collection cup, attach it to the filter element with the float, and tighten it clockwise (13) by hand tightening. Do not use any tools.
- Manually close the drain valve. Reconnect the sensor cable.
- Open the fuel valve.
- Prime the fuel system. See "Priming the Fuel System".

## **⚠ DANGER**

Be sure to prime. If air is mixed with fuel, seizure of the fuel pump and injector may occur.

- Check for fuel leaks.

### **PRIMING THE FUEL SYSTEM**

- Turn the ignition key to position "I" (electrical contact) and hold it in that position for 10-15 seconds. This will allow the fuel system's electric pump to prime the fuel.
- Never use the starter to crank the engine to prime the fuel system. This could cause the starter motor to overheat and damage the coils, pinion and/or ring gear.

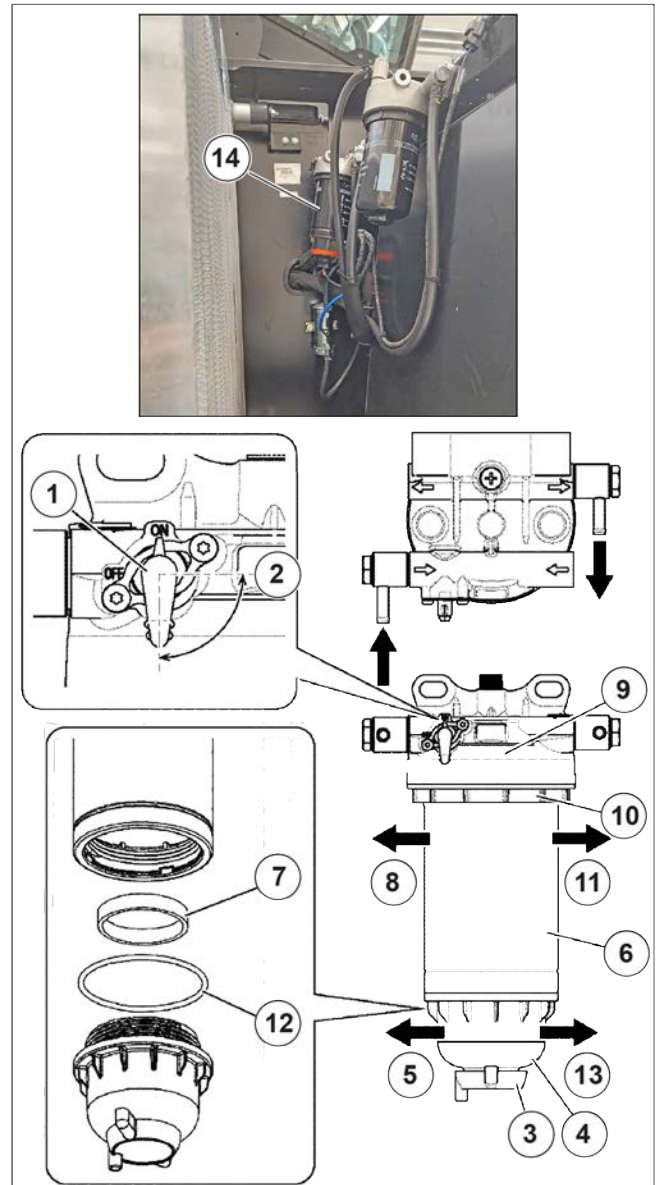

Figure 188: Fuel pre-filter replacement

### **4.7.9 FUEL FILTER REPLACEMENT**

## **⚠ DANGER**

Thoroughly clean the outside of the filter as well as its holder to prevent dust from entering the system.

- Place the telehandler on a horizontal surface, stop the three-phase motor and let it cool down.
- Open the engine cover and locate the fuel filter (5).
- Close the water separator fuel valve.
- By hand or using a pliers type filter wrench, turn the fuel filter counterclockwise (1) to remove it. When using a filter removal wrench, apply it to the resin part (2) on the filter element.

- Remove the filter, hold it carefully so as not to spill fuel. Wipe up the spilled fuel.
- Clean the filter mounting surface and apply a small amount of diesel to the gasket of the new fuel filter.
- Screw and secure a new fuel filter to the head (3) by manually turning the filter clockwise (4) and tighten it until it hits the head (3). The tightening torque is  $30 \text{ Nm} \pm 5 \text{ Nm} - 3 \text{ kgf-m} \pm 0.5 \text{ kgf-m}$ .
- Open the water separator fuel valve.
- Prime the fuel system.
- Check for fuel leaks.

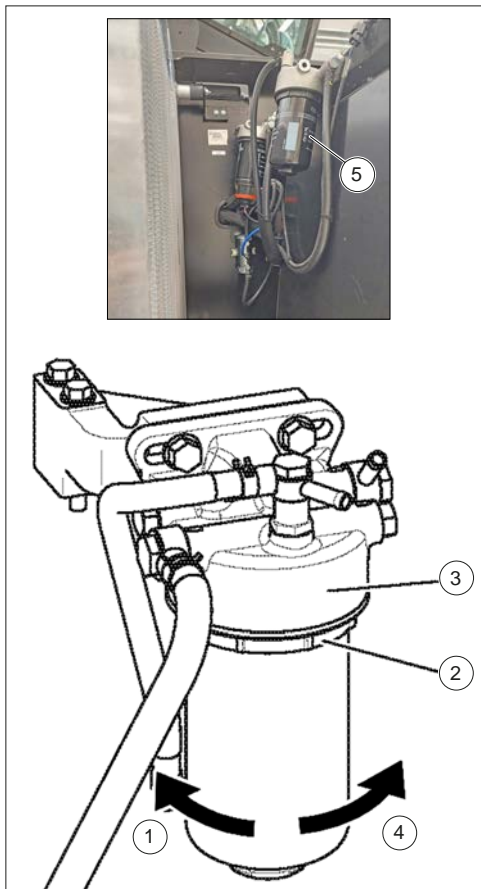

Figure 189: Fuel filter replacement

### 4.7.10 FUEL PUMP FILTER REPLACEMENT

- Place the telehandler on a horizontal surface, stop the three-phase motor and let it cool down.
- Open the engine cover and locate the fuel pump filter (1).
- Close the water separator fuel valve.
- Using a 17mm / 0.66in hex wrench (2) unscrew the fuel pump filter cover (3) and extract the filter cartridge (4).

- Clean the filter cartridge (4) with a jet of air and check that it is not damaged. If necessary, replace it with one of the same characteristics.
- Otherwise reinstall in the fuel pump filter (1).
- Close the lid (3).
- Reopen the water separator fuel valve.

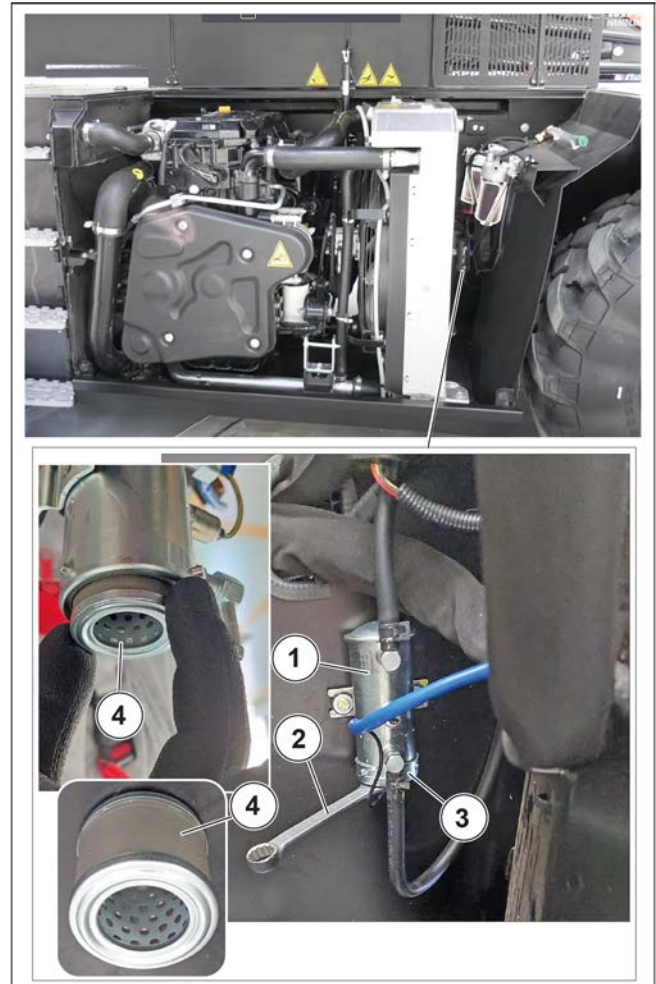

Figure 190: Fuel pump filter replacement

### 4.7.11 COOLANT REPLACEMENT

This series of operations must be carried out when necessary or at least once every 2 years when winter arrives. Place the telehandler on a level surface, with the heat engine off and cold.

**⚠ DANGER**

The three-phase motor does not contain any anti-corrosive elements and must always be filled with a minimum mixture of 25% ethylene glycol based antifreeze.

#### Coolant drain

Carry out work on the cooling system only if the coolant temperature is below 50° C.

- Open the engine cover.
- Open the access door (1) under the drain plug (2).



*When disassembling the access panel, clean all around and remove any buildup of flammable materials.*

- Slowly open the cap (3) of the coolant filler neck (4) on the radiator to relieve the excess pressure, then remove the cap (3).
- Place a container under the radiator drain plug (2) and unscrew it.
- Take the exhaust pipe located in the engine compartment (5).
- Place the end of the drain hose into the container and screw the hose (5) firmly onto the drain fitting (2).
- Allow the cooling circuit to drain completely, checking that the orifices do not clog.
- Check the condition of the rubber hoses and fixing clamps, replace the rubber hoses if necessary.
- Rinse the circuit with clean water and use a cleaning product if necessary.
- Remove, clean and replace the drain hose (5).
- Refit and tighten the radiator drain plug (2).

#### Refilling the coolant

- Slowly fill the circuit with coolant through the filler neck (4).
- Fill the cooling circuit level up to the center of the indicator (6) through the filler neck (4).
- Screw the radiator filler cap (3) back on.
- Run the engine at low speed for a few minutes.
- Check for any leaks.
- Check the level (6) and top up if necessary.
- Reinstall the access panel (1) and close the engine hood.

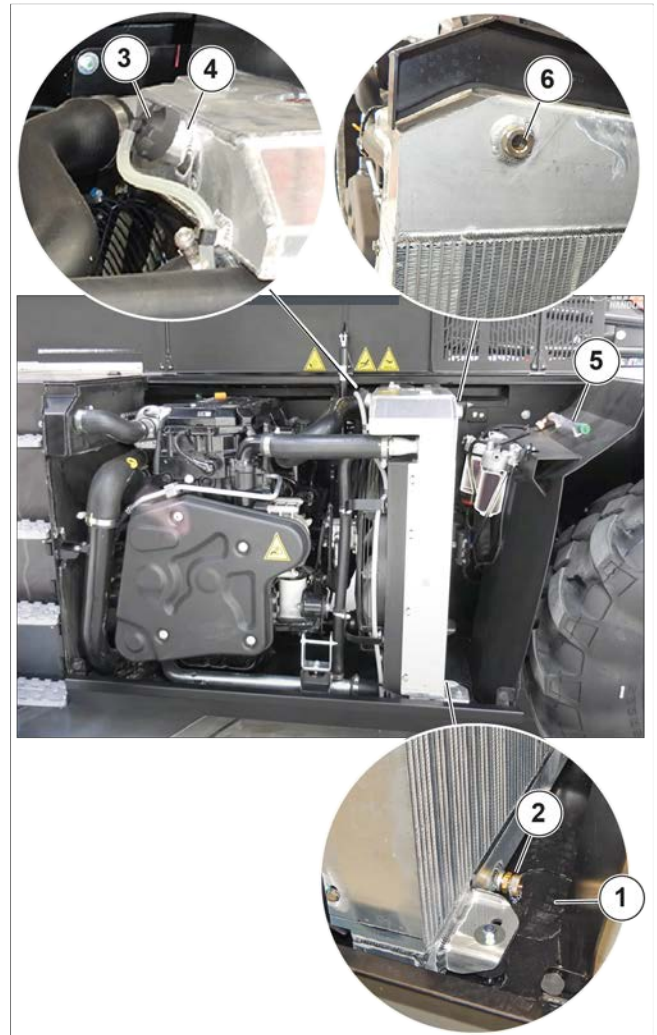

Figure 191: Coolant replacement

#### 4.7.12 CABIN VENTILATION FILTERS REPLACEMENT

1. Stop the engine.
2. Remove the air intake (1) fixed on the cover behind the cabin to access the primary (2) and secondary (3) ventilation filter.
3. Remove the grille (4) that protects the filters (2 and 3) by unscrewing the knob (5).
4. Remove the primary (2) and secondary (3) filter by pulling it from the flap (3a) and replace them with new ones.
5. Reposition the secondary filter (3) and then the primary filter (2) in its seat.
6. Refit the grille (4) that protects the filters (2 and 3) locking it by screwing the knob (5).

- 7. Refit and secure the air intake (1) on the cover behind the cabin.

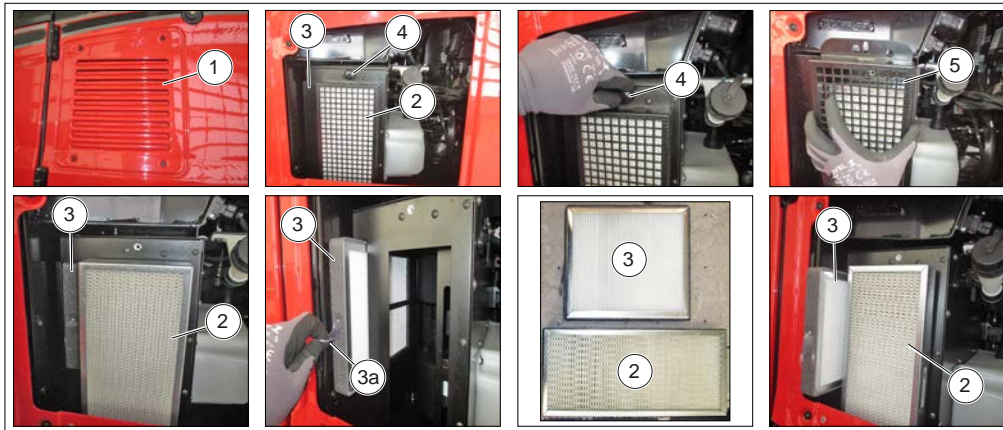

Figure 192: Cabin ventilation filters replacement

### 4.7.13 WEAR OF THE EXTERNAL TELESCOPIC BOOM CHAINS CHECK

(only for MRT 2260, MRT-X 2260, MRT 2660, MRT-X 2660)

On chains, wear manifests itself in various places.

- On the joints, which results in a stretching of the chain.
- On the profile of the plates for contact with the pulleys.
- On the surfaces of the plates and the axes protruding by contact with the jaws of the pulleys.

- On the alignment of the shoulders of the protruding axes.

#### Lengthening of the chains

For this operation, we recommend the use of the chain control ruler.

- Place the telehandler on the stabilizers, with the boom horizontal.
- Fully extend the telescopic booms and insist on the command for a few moments to tighten the chains well.
- If the wear is not likely to be uniform along the entire length, divide the chain into 4 equal parts, and check the center of each part using the ruler.

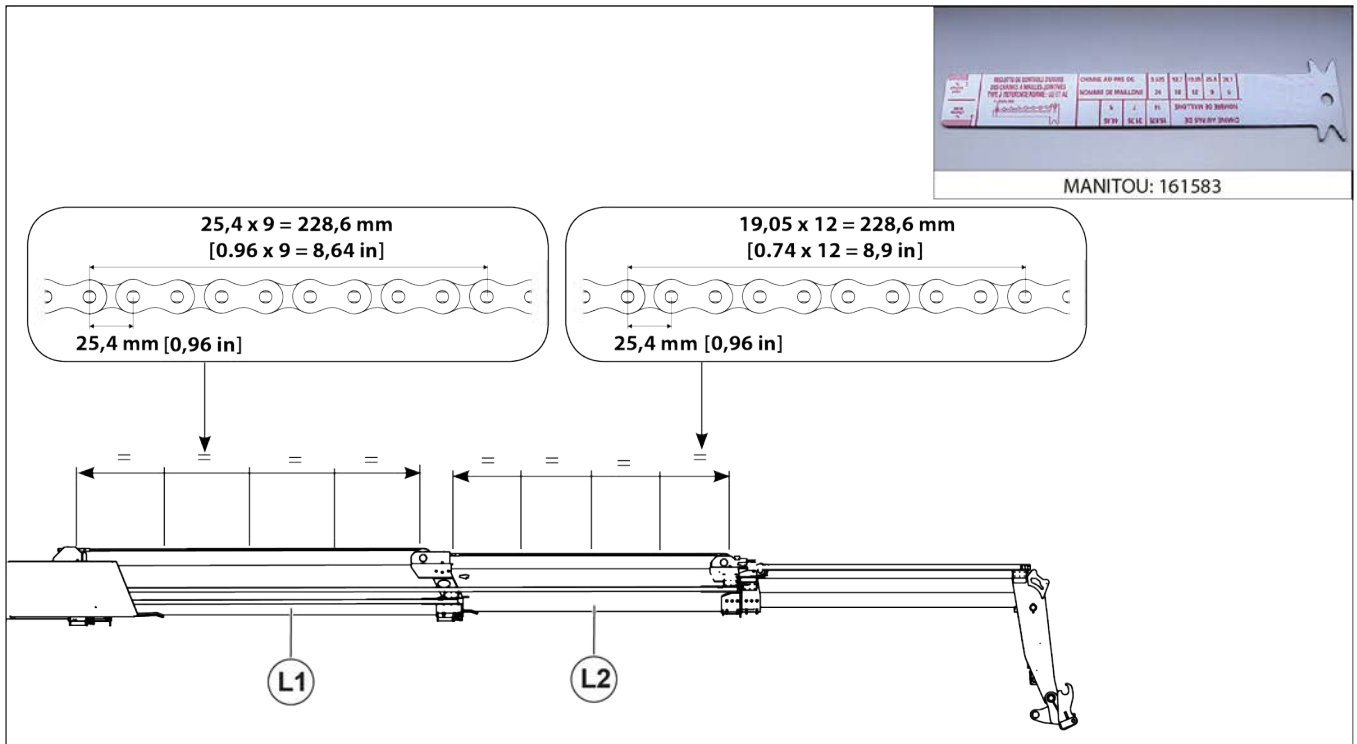

Figure 193: Wear of the external telescopic boom chains check

### **⚠ DANGER**

Beyond the maximum value ( $228.6 \text{ mm} + 2\% = 233.2 \text{ mm}$ ) [ $8.9 \text{ in} + 2\% = 10.7 \text{ in}$ ], replace the pair of chains. Contact your dealer.

#### Wear of the profile of the plates

As for the lengthening of the chains, check the center of each equal part using a vernier gage.

### **⚠ DANGER**

Beyond the mini value ( $20.60 \text{ mm} - 2\% = 20.19 \text{ mm}$ ) [ $0.81 \text{ in} - 2\% = 0.79 \text{ in}$ ], ( $18 \text{ mm} - 2\% = 17.64 \text{ mm}$ ) [ $0.7 \text{ in} - 2\% = 0.68 \text{ in}$ ], replace the pair of chains. Contact your dealer.

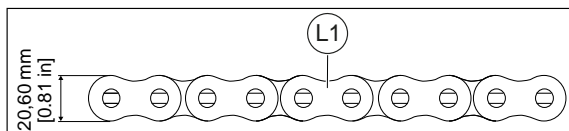

Figure 194: Wear of the profile of the plates 1

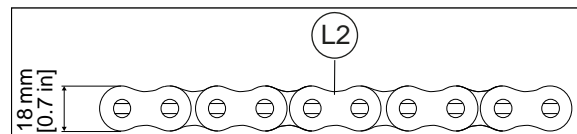

Figure 195: Wear of the profile of the plates 2

#### Wear of the protruding axles

As for the lengthening of the chains, check the center of each equal part using a vernier gage.

### **⚠ DANGER**

Beyond the mini value ( $44.15 \text{ mm} - 2\% = 43.26 \text{ mm}$ ) [ $1.73 \text{ in} - 2\% = 1.69 \text{ in}$ ], replace the pair of chains. Contact your dealer.

In addition to wear, the high pressures between the profile of the plates and the pulleys can cause an upset of material which causes a blockage of the joints; also in this case replace the pair of chains.

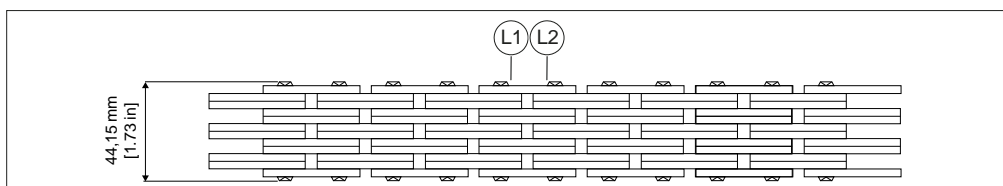

Figure 196: Wear of the protruding axles

**Alignment of the shoulders of the protruding axes**

Check the entire length of the chains. Strong friction between the plates and the protruding axes can cause the latter to rotate in the outer plates with consequent coming out of the seat. If the shoulders are not aligned in the longitudinal direction of the chain, replace the pair of chains (See your dealer).

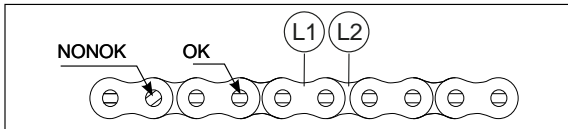

Figure 197: Alignment of the shoulders of the protruding axes

**4.7.14 WEAR OF THE EXTERNAL TELESCOPIC BOOM CHAINS CHECK**

(only for MRT 2570, MRT-X 2570, MRT 3060, MRT-X 3060, MRT 3570, MRT-X 3570, MRT 3570 ES, MRT-X 3570 ES)

On chains, wear manifests itself in various places:

- On the joints, which results in a stretching of the chain.
- On the profile of the plates for contact with the pulleys.
- On the surfaces of the plates and the axes protruding by contact with the jaws of the pulleys.
- On the alignment of the shoulders of the protruding axes.

**Lengthening of the chains**

For this operation, we recommend the use of the chain control ruler.

- Place the telehandler on the stabilizers, with the boom horizontal.
- Fully extend the telescopic booms and insist on the command for a few moments to tighten the chains well.
- If the wear is not likely to be uniform along the entire length, divide the chain into 4 equal parts, and check the center of each part using the ruler.

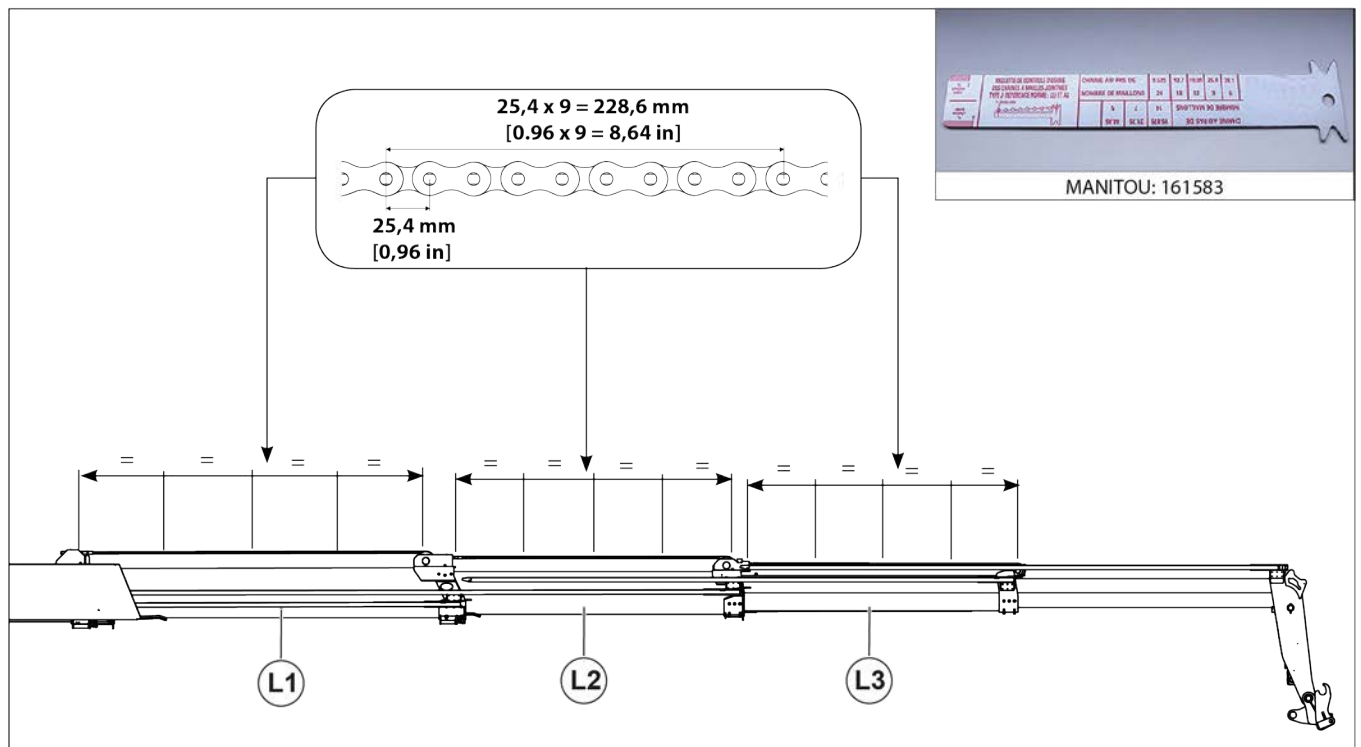

Figure 198: Lengthening of the chains

**⚠ DANGER**

Beyond the maximum value (228.6 mm + 2% = 233.2 mm) [8.64 in + 2% = 9.18 in], replace the pair of chains. Contact your dealer.

**Wear of the profile of the plates**

As for the lengthening of the chains, check the center of each equal part using a vernier gage.

**⚠ DANGER**

Beyond the mini value (23.85 mm - 2% = 23.38 mm) [0.93 in - 2% = 0.91 in], (20.60 mm - 2% = 20.19 mm) [0, 81 in - 2% = 0.79 in], replace the pair of chains (See your dealer).

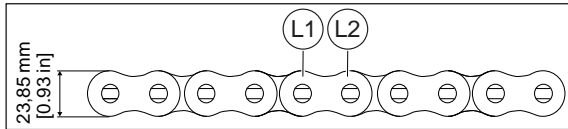

Figure 199: Wear of the profile of the plates 1

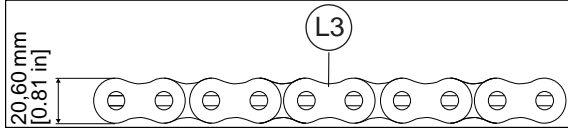

Figure 200: Wear of the profile of the plates 2

### Wear of the protruding axes

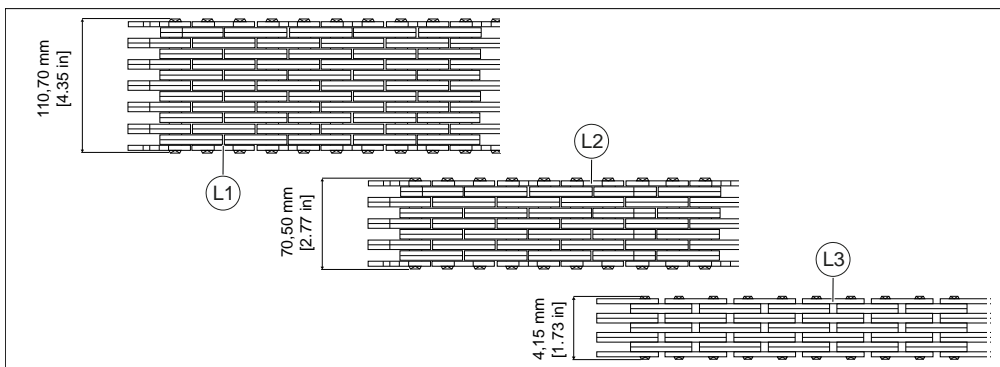

Figure 201: Wear of the protruding axes

### Alignment of the shoulders of the protruding axes

Check the entire length of the chains.

Strong friction between the plates and the protruding axes can cause the latter to rotate in the outer plates with consequent coming out of the seat.

If the shoulders are not aligned in the longitudinal direction of the chain, replace the pair of chains. Contact your dealer.

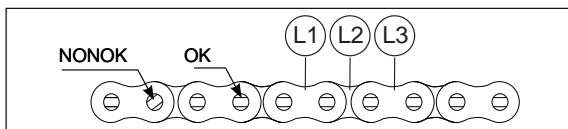

Figure 202: Alignment of the shoulders of the protruding axes

### 4.7.15 CHECK FOR WEAR AND INCREASE IN CLEARANCE OF THE FIFTH WHEEL BEARINGS

The clearance of the bearings with a new machine, measured in the factory, has an initial reference value of  $0.05 \div 0.35$  mm.

The maximum wear limit value of the bearing clearance is 2.3 mm and if a higher value is measured during a check, the washer must be replaced. As wear increases

As for the lengthening of the chains, check the center of each equal part using a vernier gage.

**⚠ DANGER**

Beyond the mini value ( $110.70 \text{ mm} - 2\% = 108.48 \text{ mm}$ ) [ $4.35 \text{ in} - 2\% = 4.27 \text{ in}$ ], ( $70.50 \text{ mm} - 2\% = 69.09 \text{ mm}$ ) [ $2.77 \text{ in} - 2\% = 2.72 \text{ in}$ ], ( $41.15 \text{ mm} - 2\% = 40.83 \text{ mm}$ ) [ $1.62 \text{ in} - 2\% = 1.6 \text{ in}$ ] replace the pair of chains. Contact your dealer.

In addition to wear, the high pressures between the profile of the plates and the pulleys can cause an upset of material which causes a blockage of the joints; also in this case replace the pair of chains.

intensify checks.

The test must be performed using a clock comparator with a centesimal scale, with the bearing stationary.

The oscillation between a condition with a negative moment and one with a positive moment will be detected.

Place the forklift on a flat surface, without load and with the boom raised to the maximum.

Then place the comparator between the turret and the chassis, as in the photo (1).

Check that everything is in order, lower the boom until it approaches the comparator and reset the clock. (negative condition).

Then raise the boom to the max and read the axial clearance value on the clock (positive condition).

The measured values compared with the maximum limit value provide the extent of wear.

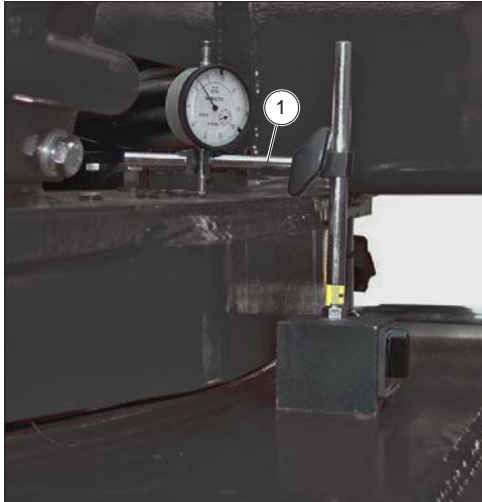

Figure 203: Check for wear and increase in clearance of the fifth wheel bearings

### 4.7.16 REPLACE FILTER OF THE "DEF" BOOST PUMP

Place the telehandler on a level surface with the three-phase motor off.

#### ⚠ WARNING

##### Risk of corrosive substances

The diesel emissions additive is a corrosive product. Protect the bodywork and wear personal protective equipment (gloves and goggles). Thoroughly clean the exterior of the pump to prevent dust from entering the system.

#### ⚠ WARNING

##### High temperature risk

Before replacing the filter (4), make sure that all parts are sufficiently cooled. Be sure to replace the filter when the "DEF" additive level is low. Beware of "DEF" spillage when removing the filter cover.

##### Replace the filter element (4)

Place the telehandler on a level surface.

- Stop the three-phase motor and wait for the "DEF" boost pump (6) to stop.
- Remove the panel (5) behind the "DEF" tank to access the "DEF" boost pump.
- Unscrew the pump cover (1), remove the compensator (2) and throw it away.
- Insert the extractor (3) (supplied with the new filter) into the filter element (4) until you hear a click.

- Pull the extractor to take out the filter element and then throw it away.
- Lightly lubricate the cover joint with suitable engine oil.
- Install the new filter element and compensator in the pump and screw the cover 1 (tightening torque: 20 +5 Nm - 2 +0.5 kgf-m).

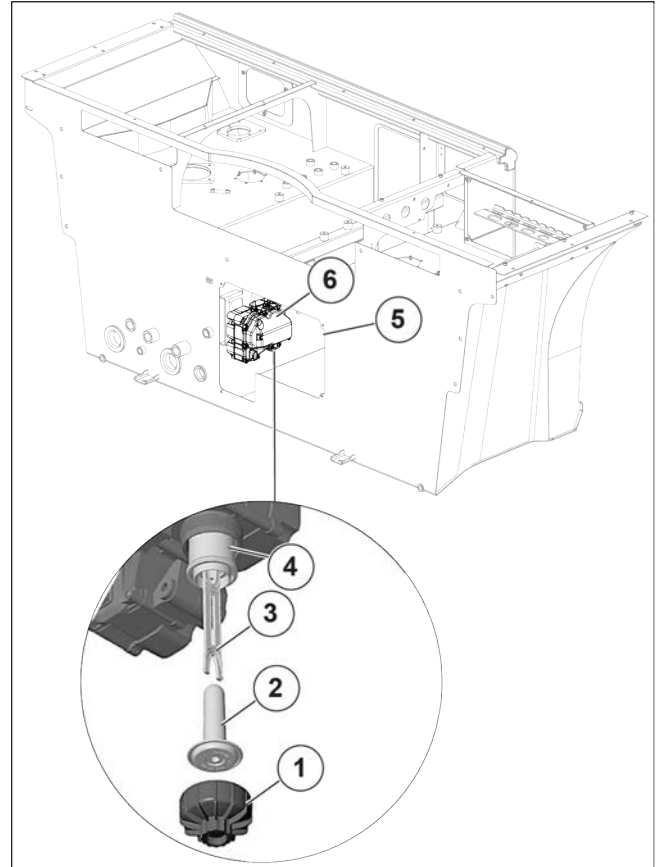

Figure 204: Replace filter of the "DEF" boost pump

### 4.7.17 REPLACE THE "DEF" TANK BREATHER

Place the telehandler level and stabilized. Stop the three-phase motor.

- Remove the panel (1) above the tanks to access the "DEF" tank breather (2).
- Unscrew the breather (2) and replace it with a new one.
- Refit the panel (1) above the tanks.

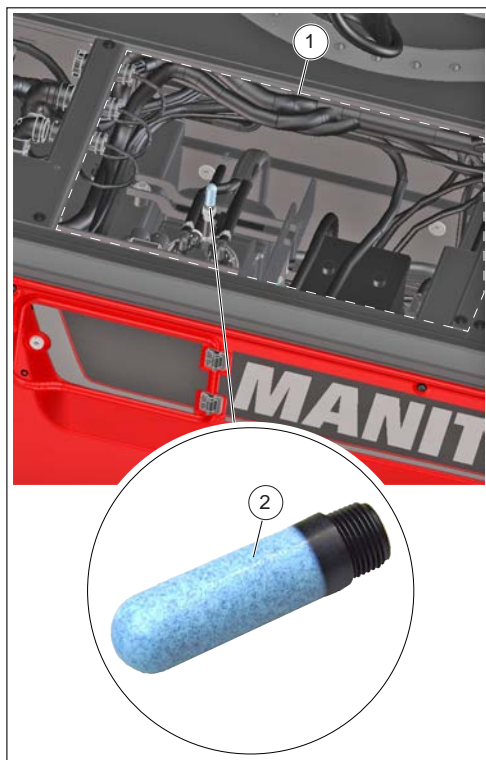

Figure 205: Replace the "DEF" tank breather

#### 4.7.18 SAFETY BELT CHECK

### **⚠ DANGER**

Under no circumstances may the forklift be used with a defective seat belt (fastening, locking, stitching, tearing, etc.). Repair or replace the seat belt immediately.

#### TWO-POINT SAFETY BELT

Check the following points:

- The fixing of the anchor points on the seat.
- Cleaning the belt and locking mechanism.
- The click of the locking mechanism.
- The state of the belt (tears, fraying).

#### AUTOMATIC SEAT BELT WITH TWO ANCHOR POINTS

Check the points listed above and the following:

- The correct running of the belt.
- The status of the reel masks.
- The locking of the reel mechanism by pulling the belt with a sharp jerk.

### **⚠ DANGER**

Following an accident, replace the seat belt.

#### SILENT BLOCK OF THE THREE-PHASE MOTOR CHECK

Contact your dealer.

#### CHECK AND ADJUSTMENT OF THE THREE-PHASE MOTOR AIR INTAKE SYSTEM

Contact your dealer.

#### THREE-PHASE MOTOR HOSES AND PIPES CHECK

Contact your dealer.

#### BRAKE CIRCUIT PRESSURE CHECK

Contact your dealer.

#### CHECK FOR WEAR OF THE TELESCOPIC BOOM SHOES

#### CONDITIONS OF THE HARNESES AND CABLES CHECK

#### LIGHTING AND SIGNALING CHECK

#### SIGNALERS CHECK

#### CONDITIONS OF THE REAR VIEW MIRRORS CHECK

Contact your dealer.

#### CABIN STRUCTURE INTEGRITY CHECK

Contact your dealer.

#### CHASSIS STRUCTURE INTEGRITY CHECK

Contact your dealer.

#### INTEGRITY OF JIBS & CRANES AND SUSPENSION LINKS (Only for: MRT 3570 ES, MRT-X 3570 ES)

Contact your dealer.

#### QUICK COUPLING OF ATTACHMENTS CHECK

Contact your dealer.

### CONDITIONS OF THE ATTACHMENTS CHECK

Contact your dealer.

### SERVICE AND PARKING BRAKE CHECK

Contact your dealer.

## 4.8. EVERY 2000 HOURS OF OPERATION OR EVERY 2 YEARS

### 4.8.1 TIRE PRESSURE AND WHEEL NUT TIGHTENING CHECK

Check the condition of the tires for cuts, bumps, wear, etc.

Using a torque wrench, check the tightening torque of the wheel bolts.

Front wheels: 680 Nm ± 15%

Rear wheels: 680 Nm ± 15%

### 4.8.2 HYDRAULIC OIL REPLACEMENT AND HYDRAULICS INTAKE FILTER CARTRIDGE CLEANING

Place the telehandler flat and stabilized.  
Fully retract and lower the telescopic boom.  
Stop the three-phase motor.



Before each intervention, thoroughly clean around the drain plugs and the suction nozzle of the hydraulic tank. Use a very clean bowl and funnel. Also clean the top of the oil can before filling. Dispose of waste oil in an environmentally friendly manner.

#### Oil drain

- Remove the panel (5) to access the oil filler cap (2). Remove the cap (2) to facilitate draining.
- Place a suitable container under the drain plug (1) and unscrew it.
- Remove the drain plug (1) to drain the hydraulic oil from the tank.
- Refit and tighten the drain plug (1).

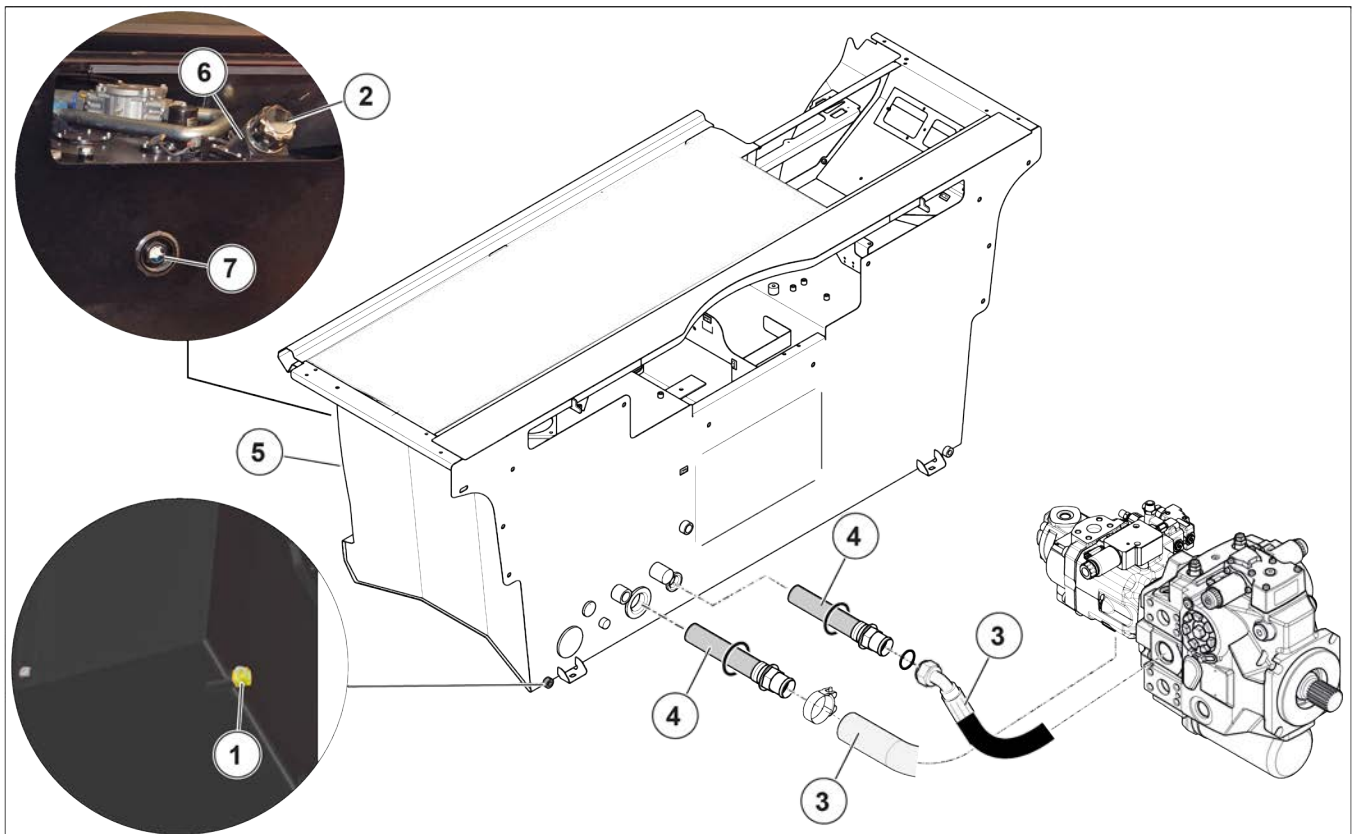

Figure 206: Hydraulic oil replacement and hydraulics intake filter cartridge cleaning

**Cleaning the strainer**

- Disconnect the hose (3).
- Unscrew the suction strainer (4), clean it with a jet of compressed air, check its condition and replace it if necessary.
- Reassemble the suction strainer checking that the gasket is correctly positioned.

**Filling with oil**

Fill the tank with new oil through the filler neck (6) until the oil level is equidistant between the lower and upper reference marks of the level indicator (7).

Check for leaks from the drain hole (1).

Refit the oil tank filler cap (2).

**De-pollution of the hydraulic circuit**

Let the three-phase motor run (accelerator pedal halfway) for 5 minutes without any load on the forklift; afterwards, for another 5 minutes using all the hydraulic movements (except the direction and service brakes).

Bring the three-phase motor to maximum speed for 1 minute; then apply the direction and service brakes.

This operation allows the circuit to be cleaned by means of the hydraulic oil filter on the intake.

**RADIATOR CHECK**

Contact your dealer.

**TRANSMISSION PRESSURES CHECK**

Contact your dealer.

**STEERING CHECK**

Contact your dealer.

**CONDITION OF THE BOOM ASSEMBLY CHECK**

Contact your dealer.

**ARTICULATION BEARINGS AND RINGS CHECK**

Contact your dealer.

**CONDITIONS OF HOSES AND PIPES CHECK**

Contact your dealer.

**CONDITIONS OF THE CYLINDERS (LEAK, RODS)**

Contact your dealer.

**HYDRAULIC CIRCUIT PRESSURES CHECK**

Contact your dealer.

**ARTICULATION BEARINGS AND RINGS CHECK**

Contact your dealer.

**ENGINE VALVE CLEARANCE CHECK**

Contact your dealer.

**AIR CONDITIONING (OPTIONAL)**

Contact your dealer.

**CLEANING OF THE COILS OF THE CONDENSER AND EVAPORATOR****CLEANING OF THE CONDENSATE CONTAINER AND THE DISCHARGE VALVE****RECOVERY OF THE COOLANT TO REPLACE THE DRYER FILTER****FILLING WITH COOLANT AND CHECKING THE THERMOSTATIC REGULATION AND PRESSURE SWITCHES**

*When opening the evaporator unit, do not forget to replace the lid seal.*

**⚠ WARNING****Risk of corrosive materials**

NEVER ATTEMPT TO REPAIR ANY ANOMALIES BY YOURSELF. TO CHARGE A CIRCUIT ALWAYS CONTACT THE DEALER WHO HAS THE SUITABLE SPARE PARTS, THE TECHNICAL NOTIONS AND THE NECESSARY TOOLS. In the following cases, contact a doctor. If inhaled, take the person to an open environment. In case of skin contact, rinse immediately with plenty of running water. In case of frostbite, apply a sterile dressing. In case of contact with eyes, rinse with fresh water for about 15 minutes.

**IMPORTANT INFORMATION CONCERNING THE COOLANT USED**

- This product contains fluorinated greenhouse gases relevant under the Kyoto protocol.
- Type of coolant: R134A; colorless and odorless and heavier than air. It has a PRG (Global Warming Potential) value of 1430.

- Never let the gas escape into the atmosphere. Never open the circuit as this would cause a loss of coolant.
- The compressor is equipped with an oil level indicator. Never unscrew this indicator: this will drain the circuit. The oil level should only be checked when changing the oil.

## 4.9. EVERY 3000 HOURS OF OPERATION OR EVERY 3 YEARS

### 4.9.1 AIR FILTER SAFETY CARTRIDGE REPLACEMENT

- Remove/refit the dry air filter cartridge to locate the safety filter of the air filter.
- Carefully pull out the dry air filter safety cartridge (1) to minimize dust escaping.
- Carefully clean the seat of the filter seals with a damp, clean, lint-free cloth.
- Before refitting, check the condition of the new safety cartridge.
- Insert the cartridge into the filter and position it by pressing on the edge of the cartridge and not in the center.



*The frequency of replacement of the safety cartridge is given for information only. It must be replaced after every three dry air filter cartridge replacements.*

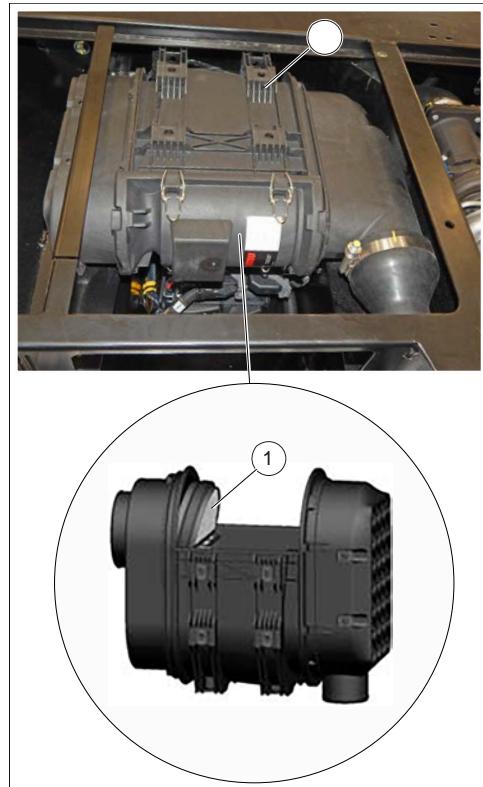

Figure 207: Air filter safety cartridge replacement

### 4.9.2 REPLACEMENT OF THE THREE-PHASE MOTOR SERVICE BELT

- Open the engine cover and lower cover.
- Remove the protective casing 1.
- Insert a socket wrench on the square rod of the automatic tensioner 2 to loosen the belt and extract it.
- Release the force and remove the socket wrench.
- Refit a new alternator belt, checking that it is well positioned in the recesses of each pulley and tension the belt using the automatic tensioner 2.



*Take advantage of the belt removal to check the correct functioning of the pulleys and bearings (noise, friction, clearance, etc.).*

- Refit the protective casing 1.
- Close the lower cover and engine cover.

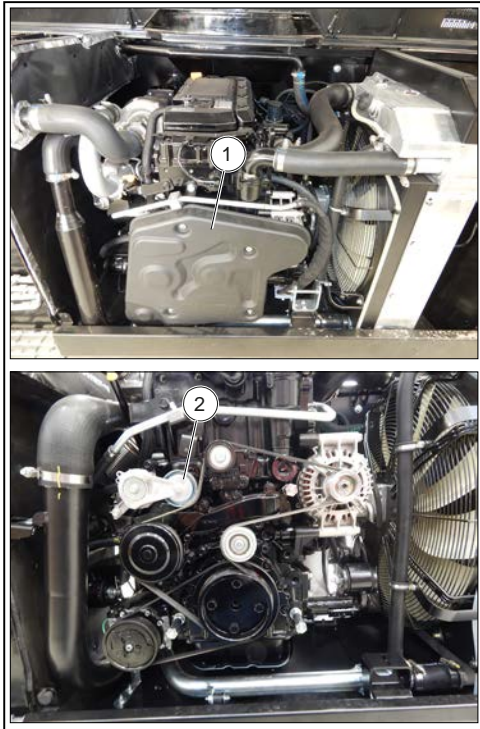

Figure 208: Replacement of the three-phase motor service belt

## 4.10. EVERY 4500 HOURS OF OPERATION OR EVERY 9 YEARS

### THREE-PHASE MOTOR CRANKCASE BREATHER CHECK

#### REPLACEMENT OF THE CRANKCASE FILTER OF THE ENGINE BREATHER

- Open the engine cover.
- Remove the upper cover (1) of the three-phase motor.
- Remove the filter (2) and replace it with a new one.
- Refit the upper casing (1).
- Close the engine cover.

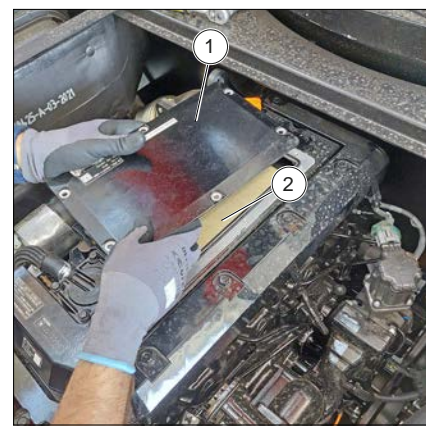
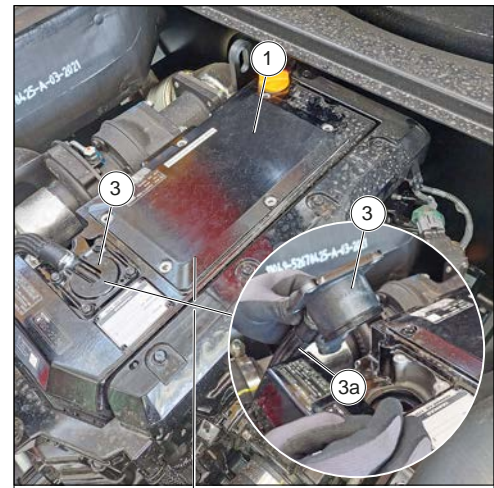

Figure 209: Replacement of the crankcase filter of the engine breather

### CONTROL UNIT (ECU), SENSORS AND ACTUATORS ASSOCIATED WITH THE THREE-PHASE MOTOR

Contact your dealer

### THREE-PHASE MOTOR TURBOCHARGER CHECK

Contact your dealer

**CHECKING AND CLEANING THE VALVE OF THE EXHAUST GAS RECIRCULATION SYSTEM (EGR) OF THE THREE-PHASE MOTOR**

Contact your dealer

**SELECTIVE CATALYTIC REDUCER (SCR) / THREE-PHASE MOTOR DIESEL OXIDATION CATALYST (DOC) CHECK**

Contact your dealer

**CHECKING AND CLEANING THE THREE-PHASE MOTOR INJECTOR**

Contact your dealer

**4.11. EVERY 6000 HOURS OF OPERATION OR EVERY 12 YEARS**

**4.11.1 DIESEL PARTICULATE FILTER (DPF) OF THE THREE-PHASE MOTOR CHECK**

Contact your dealer.

**4.12. EVERY 9000 HOURS OF OPERATION OR EVERY 18 YEARS**

**REPLACE THE DIESEL PARTICLE FILTER (DPF) OF THE THREE-PHASE MOTOR**

Contact your dealer.

**REPLACE THE SELECTIVE CATALYTIC REDUCER (SCR) OF THE THREE-PHASE MOTOR**

Contact your dealer.

**4.13. OCCASIONAL MAINTENANCE**

**4.13.1 INSERTING THE SAFETY WEDGE OF THE TELESCOPIC BOOM**



Only use the safety wedge (1) supplied with the telehandler.



**Risk of crushing**

The safety wedge must be installed by accessing the walkable surface of the undercarriage from the right side staircase.

During installation of the safety wedge, do not stand under the telescopic boom.

The telescopic handler is equipped with a safety wedge (1) which prevents accidental descent of the telescopic boom during maintenance operations of the same or in the areas below it. The boom safety wedge must be installed on the rod of the handler cylinder.

When not in use, the safety wedge (1) is positioned on the telehandler turret through its fixings (1a).

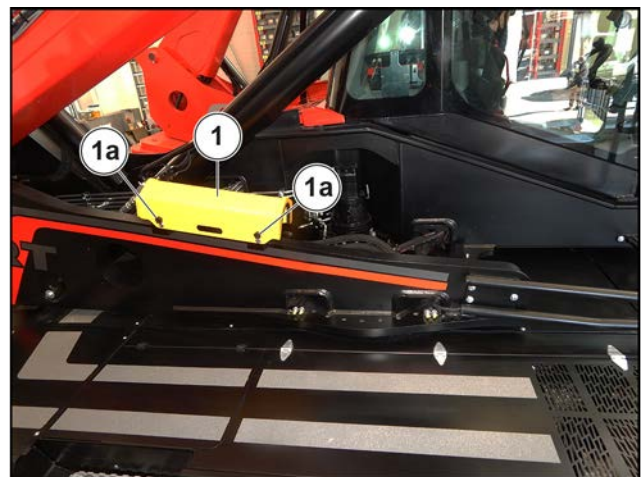

Figure 210: Boom safety wedge

**REFITTING THE WEDGE**

1. Raise the boom to the maximum.
2. Place the safety wedge 1 on the rod of the lifting cylinder and lock with the shaft 2 and the split pin 3.

- Lower the boom slowly then stop the hydraulic movements before hitting the wedge.

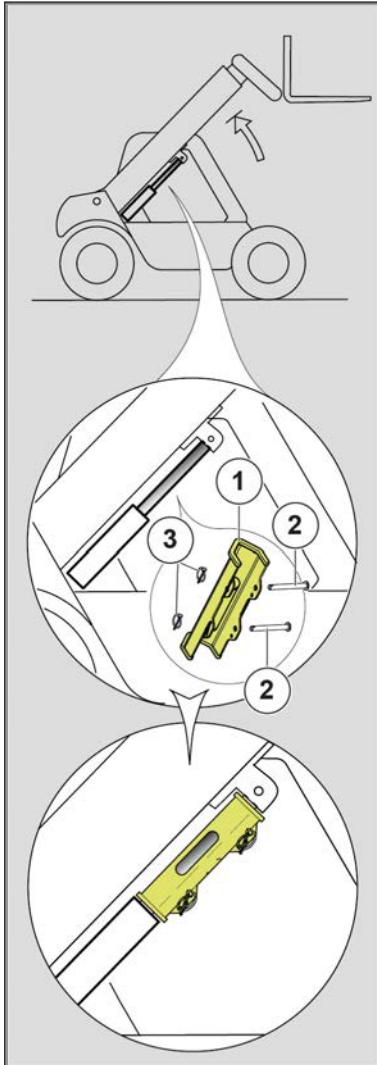

Figure 211: Inserting the safety wedge of the telescopic boom

#### DISASSEMBLY OF THE WEDGE

- Raise the boom to the maximum.
- Remove the split pin and the shaft.
- Put the safety wedge back into the compartment on the telehandler.

#### 4.13.2 WHEEL REPLACEMENT

### ⚠ DANGER

Should the wheel replacement be carried out along the road, proceed as follows:

- If possible, stop the forklift on level ground on firm ground.

- Switch off the forklift.
- Activate the parking brake.
- Turn on the hazard lights.
- Apply wedges to immobilize the forklift in both directions on the axle opposite the wheel to be replaced.
- Loosen the wheel bolts to be replaced
- Place the jack under the axle housing, as close to the wheel as possible and adjust the jack (1).
- Raise the wheel until it comes off the ground and place the safety support under the axle (2).
- To do this, we recommend that you use a hydraulic jack and safety support.
- Completely unscrew the wheel bolts and remove them.
- Pull out the wheel with back and forth movements and turn it to the side.
- Put the new wheel on the hub.
- Manually screw in the bolts, if necessary lubricate them with grease.
- Tighten the wheel bolts securely with a torque wrench.
- Remove the safety support and lower the forklift with the jack.



Figure 212: Wheel replacement

#### 4.13.3 HEADLIGHTS ADJUSTMENT

Adjustment recommendations  
(According to ECE-76/756 76/761 ECE20 standards).

Adjustment of -2% of the dipped beam headlights with respect to the horizontal axis of the headlight.

Adjustment procedure

- Place the forklift, empty, in transport position, perpendicular to a white wall, on flat and horizontal ground.
- Check the tire pressure.
- Select the direction reverser in idle off and apply the parking brake.

Calculation of the height of the dipped beam headlights (h2)

h1 = Height above the ground of the dipped beam headlights.

h2 = Height of the adjusted beam.

l = Distance between the dipped beam headlights and the white wall.

$$h2 = h1 - (lx 2/100).$$

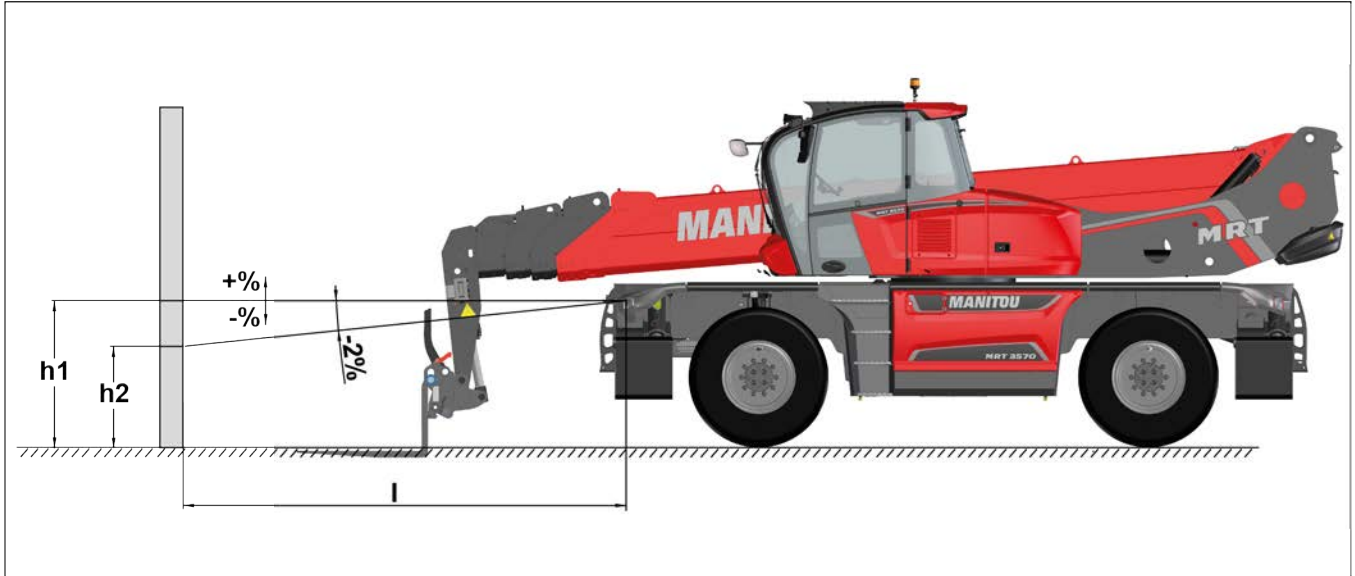

Figure 213: Headlights adjustment

### 4.13.4 REPLACING THE FUSES AND RELAYS

#### FUSE AND RELAY IN CAB

Remove the panel (1) behind the driver seat for access to the fuse box and relays (2).

**⚠ DANGER**

Always replace a faulty fuse with another of equivalent rating. Never use a fuse that has been.



Figure 214: Fuse and relay in cab

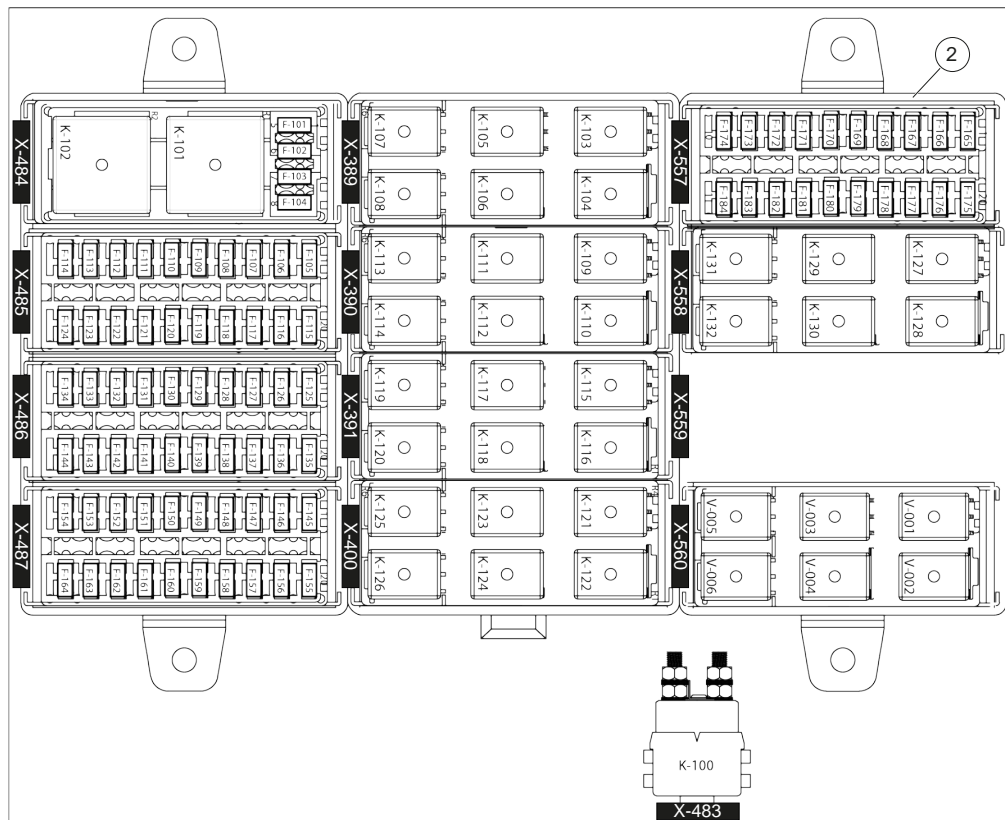





Figure 215: Overview of fuse and relays

Table 101. Specification table of the fuses and relays in cab

|  |         | <b>Functions</b>                      |
|---|---------|---------------------------------------|
| <b>X-484</b>  |         |                                       |
| K-101   | -       | Flasher unit                          |
| K-102   | 20/30 A | Cab ventilation system supply         |
| F-101   | 10 A    | "+15" Attachment solenoid (12V)       |
| F-102   | 5 A     | "+15" DSB Switch (12V)                |
| F-103   | 7.5 A   | "+15" Car radio (12V)                 |
| F-104   | 5 A     | "+15" 12V plugs (12V)                 |
| <b>X-485</b>  |         |                                       |
| F-105   | 15 A    | "+30" Bucket Mix                      |
| F-106   | 5 A     | "+30" VBATP Master SPU                |
| F-107   | 5 A     | "+30" Stand-By Display                |
| F-108   | 5 A     | "+30" Roof light                      |
| F-109   | 5 A     | "+30" OBDII Diagnostic plug           |
| F-110   | 5 A     | "+30" Red button for transmission TCU |
| F-111   | 2 A     | "+30" Anti Theft                      |
| F-112   | 3 A     | "+30" Pred. supply connector          |
| F-113   | 2 A     | "+30" DC-DC Converter                 |
| F-114   | 15 A    | "+30" A/C fan roof 1                  |
| F-115   | 15 A    | "+30" A/C fan roof 2                  |
| F-116   | -       | Available                             |
| F-117   | -       | Available                             |

|  |       | <i>Functions</i>                   |
|---|-------|------------------------------------|
| F-118   | -     | Available                          |
| F-119   | -     | Available                          |
| F-120   | -     | Available                          |
| F-121   | -     | Available                          |
| F-122   | -     | Available                          |
| F-123   | -     | Available                          |
| F-124   | 20 A  | " +30" Cab ventilation relay       |
| <b>X-486</b>  |       |                                    |
| F-125   | -     | Available                          |
| F-126   | 3 A   | " +15" Predisposition supply       |
| F-127   | 5 A   | " +15" Foot throttle supply        |
| F-128   | 5 A   | " +15" Safety/Stop remote control  |
| F-129   | 5 A   | " +15" Light lever                 |
| F-130   | 2 A   | " +15" Easy manager                |
| F-131   | -     | Available                          |
| F-132   | 10 A  | " +15" VP Midac Plus               |
| F-133   | 5 A   | " +15" Beacon                      |
| F-134   | 15 A  | " +15" Seat power supply           |
| F-135   | 15 A  | " +15" Seat inclination management |
| F-136   | -     |                                    |
| F-137   | 5 A   | " +15" Ventilation fan relay       |
| F-138   | 5 A   | " +15" Door microswitch            |
| F-139   | 5 A   | " +15" A/C - Heater control panel  |
| F-140   | 5 A   | " +15" A/C compressor Clutch       |
| F-141   | -     | Available                          |
| F-142   | 5 A   | " +15" Video camera                |
| F-143   | 5 A   | " +15" Proxy tower alignment       |
| F-144   | 20 A  | " +15" Solenoid supply             |
| <b>X-487</b>  |       |                                    |
| F-145   | 10 A  | " +15" Rear window heater          |
| F-146   | 7.5 A | " +15" Electric mirror heater      |
| F-147   | 5 A   | " +15" Electric mirror             |
| F-148   | 10 A  | " +15" Front Wiper motor           |
| F-149   | 7.5 A | " +15" Rear Wiper motor            |
| F-150   | 7.5 A | " +15" Upper Wiper motor           |
| F-151   | 7.5 A | " +15" Lateral Wiper motor         |
| F-152   | 10 A  | " +15" VBATD1 Vehicle SPU          |
| F-153   | 10 A  | " +15" VBATD2 Vehicle SPU          |
| F-154   | 10 A  | " +15" Flormart heater             |
| F-155   | 10 A  | " +15" Corner light                |
| F-156   | 10 A  | " +15" VBATD3 Vehicle SPU          |
| F-157   | 10 A  | " +15" VBATD4 Vehicle SPU          |
| F-158   | 10 A  | " +15" VBATD5 Vehicle SPU          |
| F-159   | 10 A  | " +15" VBATD6 Vehicle SPU          |
| F-160   | 10 A  | " +15" VBATD7 Vehicle SPU          |
| F-161   | 10 A  | " +15" VBATF1 Vehicle SPU          |
| F-162   | 10 A  | " +15" VBATF2 Vehicle SPU          |

|  |       | <i>Functions</i>               |
|---|-------|--------------------------------|
| F-163   | 10 A  | " +15" VBATF3 Vehicle SPU      |
| F-164   | 10 A  | " +15" VBATF4 Vehicle SPU      |
| <b>X-389</b>  |       |                                |
| K-103   | 15 A  | Front wiper 1st speed          |
| K-104   | 15 A  | Front wiper 2nd speed          |
| K-105   | 15 A  | Roof wiper                     |
| K-106   | 15 A  | Rear wiper                     |
| K-107   | 15 A  | Lateral wiper                  |
| K-108   | 15 A  | Beacon light                   |
| <b>X-390</b>  |       |                                |
| K-109   | 15 A  | Electric mirror heater         |
| K-110   | 15 A  | Flormart heater                |
| K-111   | 15 A  | Rear window heater             |
| K-112   | 15 A  |                                |
| K-113   | 15 A  | " +15" From key                |
| K-114   | 15 A  | Corner light                   |
| <b>X-391</b>  |       |                                |
| K-115   | 15 A  | Direction light LH             |
| K-116   | 15 A  | Direction light RH             |
| K-117   | 15 A  | Easy link no keypad (OPT)      |
| K-118   | 15 A  | Easy link with keypad (OPT)    |
| K-119   | 15 A  | Cabin ventilation              |
| K-120   | 15 A  | Solenoid Supply                |
| <b>X-400</b>  |       |                                |
| K-121   | 15 A  | Unlocking 3D basket            |
| K-122   | 15 A  | Rotation 3D basket             |
| K-123   | 15 A  | Lifting 3D basket              |
| K-124   | 15 A  | Tilting 3D basket              |
| K-125   | 15 A  | 12V Out Boom head              |
| K-126   | 15 A  | -                              |
| <b>X-557</b>  |       |                                |
| F-165   | 7.5 A | " +15" Front cab working light |
| F-166   | 7.5 A | " +15" Rear cab working light  |
| F-167   | 10 A  | " +15" Boom working light      |
| F-168   | -     | Available                      |
| F-169   | -     | Available                      |
| F-170   |       | Available                      |
| F-171   | -     | Available                      |
| F-172   | -     | Available                      |
| F-173   | 5 A   | " +15" Spot and ladder light   |
| F-174   | -     | Available                      |
| F-175   | 15 A  | " +15" Basket supply           |
| F-176   | 5 A   | " +15" Joystick                |
| F-177   | 5 A   | " +15" Navi Encoder            |
| F-178   | 5 A   | " +15" OBD Diagnostic plug     |
| F-179   | 10 A  | " +15" Boom pressure sensor    |

|  |      | <i>Functions</i>        |
|---|------|-------------------------|
| F-180   | 5 A  | "+15" Slip Ring encoder |
| F-181   | 5 A  | "+15" Safety switch     |
| F-182   | 5 A  | "+15" Red button        |
| F-183   | 5 A  | "+15" Remote switch     |
| F-184   | 15 A | "+15" DC-DC Converter   |
| <b>X-558</b>  |      |                         |
| K-127   | 15 A | A/C Fan Roof 1          |
| K-128   | 15 A | A/C Fan Roof 2          |
| K-129   | 15 A | A/C Compressor clutch   |
| K-130   | 15 A | Front cab working light |
| K-131   | 15 A | Rear cab working light  |
| K-132   | 15 A | Boom working light      |
| <b>X-559</b>  |      |                         |
| -   | -    | Not used                |
| <b>X-560</b>  |      |                         |
| V-001   | 3 A  | Diode module            |
| V-002   | 3 A  | Diode module            |
| V-003   | 3 A  | Diode module            |

**FUSE AND RELAY ON THE CHASSIS**

**Only for the telehandler: MRT 2260, MRT-X 2260, MRT 2660, MRT-X 2660, MRT 2570, MRT-X 2570, MRT 3050, MRT-X 3050**

Remove the panel (1) behind the step under the cab for access to the fuse box and relays (2a - 2b).  
Remove the cap to access the fuse and relays.

** DANGER**

Always replace a faulty fuse with another of equivalent rating. Never use a fuse that has been.

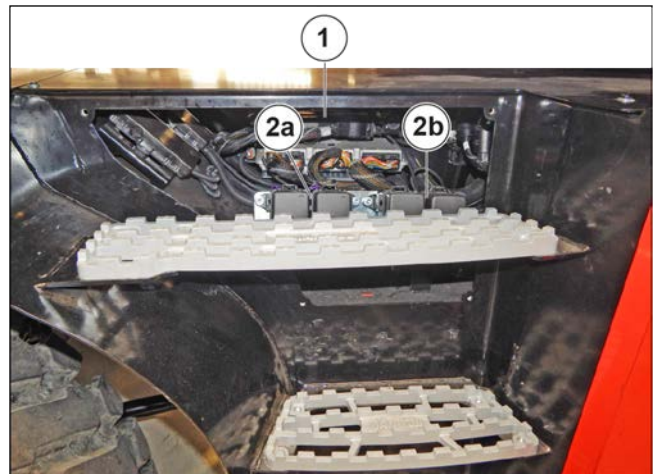

Figure 216: Fuse and relay on the chassis

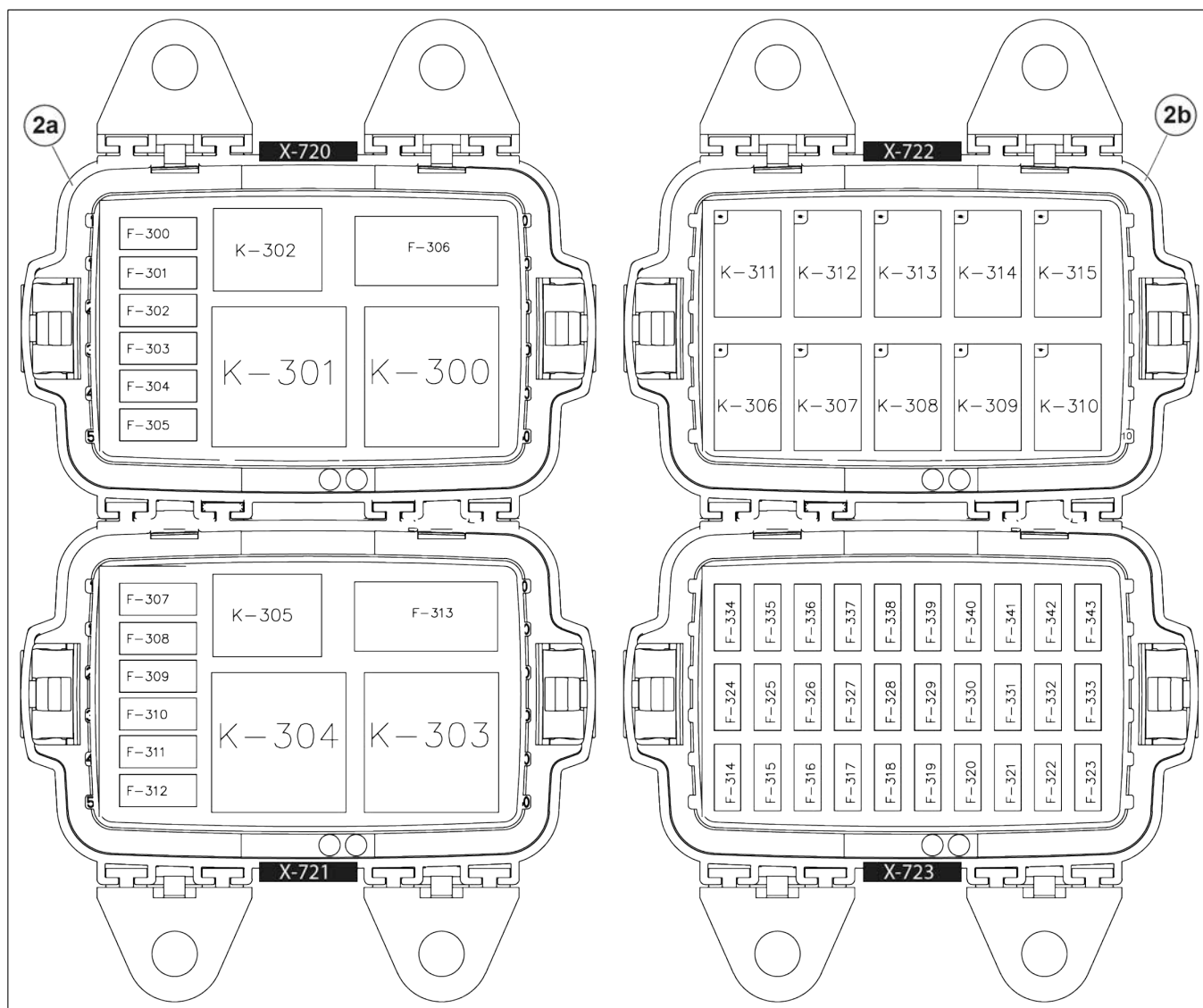





Figure 217: Overview of fuse and relays:

Table 102. Specification table of the fuses and relays on chassis

|  |      | <b>Functions</b>                        |
|---|------|---|
| <b>X-720</b>  |      |   |
| F-300   | 5 A  | Electric emergency pump                 |
| F-301   | 5 A  | "+15" Bi-Eneqy system supply            |
| F-302   | 10 A | "+15" VBATD Auxiliary SPU               |
| F-303   | 10 A | "+15" VBATE Auxiliary SPU               |
| F-304   | 5 A  | "+15" Front / rear axle alignment sens. |
| F-305   | 5 A  | "+15" Stabilizer fully up sensor        |
| F-306   | 30 A | Engine fuse box supply                  |
| K-300   | 50 A | Hydraulic oil cooler electric fan       |
| K-301   | 50 A | "+15" Vehicle power                     |
| K-302   | 15 A | Electric emergency pump                 |
| <b>X-721</b>  |      |   |

|  |         | <i>Functions</i>                      |
|---|---------|---------------------------------------|
| F-307   | 5 A     | " +30" VBATP Auxiliary SPU            |
| F-308   | 10 A    | " +30" VBATC Auxiliary SPU            |
| F-309   | 15 A    | " +30" Cab ventilation supply         |
| F-310   | 10 A    | " +30" Water heater supply            |
| F-311   | 10 A    | " +30" Unswitched supply              |
| F-312   | 10 A    | " +30" Pneutron / Navi Encoder        |
| F-313   |         |                                       |
| K-303   | 50 A    | Hydraulic oil cooler electric fan     |
| K-304   | 50 A    | Vehicle power ECU                     |
| K-305   | 15 A    | " +15" ECU / Sensors                  |
| <b>X-722</b>  |         |                                       |
| K-306   | 20 A    | Road light relay                      |
| K-307   | 20 A    | High beam relay                       |
| K-308   | 20 A    | Low beam relay                        |
| K-309   | 20 A    | Stop light relay                      |
| K-310   | 20 A    | Reverse light relay                   |
| K-311   | 20 A    | Cranking relay                        |
| K-312   | 20 A    | Fog light relay                       |
| K-313   | 20 A    | DRL light relay                       |
| K-314   | -       |                                       |
| K-315   | -       |                                       |
| <b>X-723</b>  |         |                                       |
| F-314   | 10 A    | " +15" VBATD1 Vehicle SPU             |
| F-315   | 10 A    | " +15" VBATD2 Vehicle SPU             |
| F-316   | 10 A    | " +15" VBATD3 Vehicle SPU             |
| F-317   | 10 A    | " +15" VBATD4 Vehicle SPU             |
| F-318   | 10 A    | " +15" VBATD5 Vehicle SPU             |
| F-319   | 10 A    | " +15" VBATD6 Vehicle SPU             |
| F-320   | 10 A    | " +15" VBATD7 Vehicle SPU             |
| F-321   | 10 A    | " +15" VBATF1 Vehicle SPU             |
| F-322   | 10 A    | " +15" VBATF2 Vehicle SPU             |
| F-323   | 10 A    | " +15" VBATF3 Vehicle SPU             |
| F-324   | 10 A    | " +15" VBATF4 Vehicle SPU             |
| F-325   | 7.5 A A | " +15" Transmission Control Unit      |
| F-326   | -       | Available                             |
| F-327   | 5 A     | " +15" Hydraulic pump sensor          |
| F-328   | 5 A     | " +15" Chassis level sensor           |
| F-329   | 5 A     | " +15" Stabilizer extensometer sensor |
| F-330   | 5 A     | " +15" Stabilizer on ground sensor    |
| F-331   | 5 A     | Fog light                             |
| F-332   | 5 A     | DRL Light                             |
| F-333   | 15 A    | " +15" Cranking                       |
| F-334   | 5 A     | Road Light                            |
| F-335   | 5 A     | Road Light                            |
| F-336   | 7.5 A   | High beam                             |
| F-337   | 7.5 A   | Low beam                              |

|  |      | <i>Functions</i>          |
|---|------|---------------------------|
| F-338   | 5 A  | Stop light                |
| F-339   | 5 A  | Reverse light             |
| F-340   | 5 A  | "+30" VBATP Slave SPU     |
| F-341   | 5 A  | "+15" VE transmission TCU |
| F-342   | 15 A | "+30" VP transmission TCU |
| F-343   | 10 A | "+30" Main key            |

**FUSE AND RELAY ON THE CHASSIS**

Only for the telehandler: MRT 3570, MRT-X 3570

Remove the panel (1) behind the step under the cab for access to the fuse box and relays (2a - 2b).  
Remove the cap to access the fuse and relays.

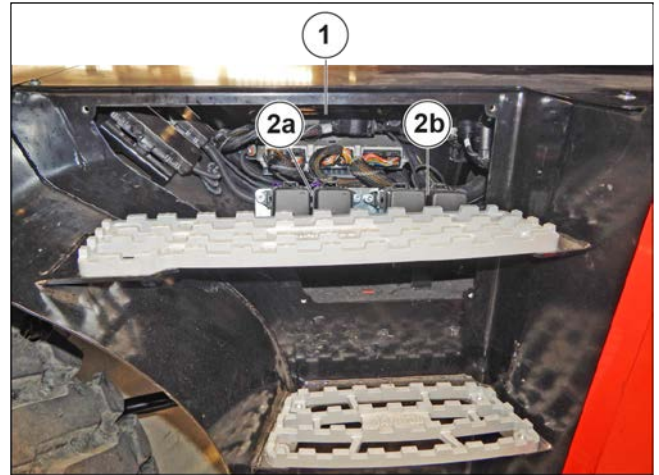

Figure 218: Fuse and relay on the chassis

**⚠ DANGER**

Always replace a faulty fuse with another of equivalent rating. Never use a fuse that has been.

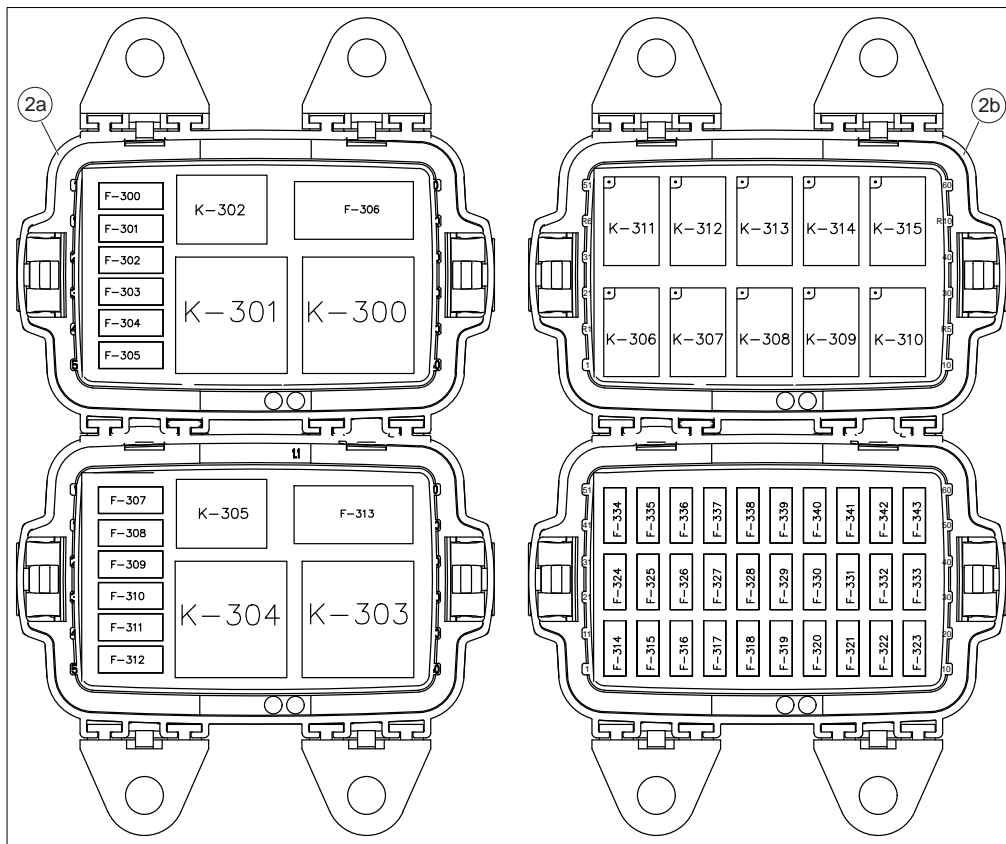



Figure 219: Overview of fuse and relays:

Table 103. Specification table of the fuses and relays on chassis

|  |      | Functions                                 |
|---|------|---|
| <b>X-720</b>  |      |   |
| F-300   | 5 A  | Electric emergency pump                   |
| F-301   | 5 A  | " +15 " Bi-Eneqy system supply            |
| F-302   | 10 A | " +15 " VBATD Auxiliary SPU               |
| F-303   | 10 A | " +15 " VBATE Auxiliary SPU               |
| F-304   | 5 A  | " +15 " Front / rear axle alignment sens. |
| F-305   | 5 A  | " +15 " Stabilizer fully up sensor        |
| F-306   | 30 A | Engine fuse box supply                    |
| K-300   | 50 A | Hydraulic oil cooler electric fan         |
| K-301   | 50 A | " +15 " Vehicle power                     |
| K-302   | 15 A | Electric emergency pump                   |
| <b>X-721</b>  |      |   |
| F-307   | 5 A  | " +30 " VBATP Auxiliary SPU               |
| F-308   | 10 A | " +30 " VBATC Auxiliary SPU               |
| F-309   | 15 A | " +30 " Cab ventilation supply            |
| F-310   | 10 A | " +30 " Water heater supply               |
| F-311   | 10 A | " +30 " Unswitched supply                 |
| F-312   | 10 A | " +30 " Pneutron / Navi Encoder           |
| F-313   |      |   |
| K-303   | 50 A | Hydraulic oil cooler electric fan         |
| K-304   | 50 A | Vehicle power ECU                         |
| K-305   | 15 A | " +15 " ECU / Sensors                     |
| <b>X-722</b>  |      |   |
| K-306   | 20 A | Road light relay                          |
| K-307   | 20 A | High beam relay                           |
| K-308   | 20 A | Low beam relay                            |
| K-309   | 20 A | Stop light relay                          |
| K-310   | 20 A | Reverse light relay                       |
| K-311   | 20 A | Cranking relay                            |
| K-312   | 20 A | Foq light relay                           |
| K-313   | 20 A | DRL light relay                           |
| K-314   | -    |   |
| K-315   | -    |   |
| <b>X-723</b>  |      |   |
| F-314   | 10 A | " +15 " VBATD1 Vehicle SPU                |
| F-315   | 10 A | " +15 " VBATD2 Vehicle SPU                |
| F-316   | 10 A | " +15 " VBATD3 Vehicle SPU                |
| F-317   | 10 A | " +15 " VBATD4 Vehicle SPU                |
| F-318   | 10 A | " +15 " VBATD5 Vehicle SPU                |
| F-319   | 10 A | " +15 " VBATD6 Vehicle SPU                |
| F-320   | 10 A | " +15 " VBATD7 Vehicle SPU                |
| F-321   | 10 A | " +15 " VBATF1 Vehicle SPU                |
| F-322   | 10 A | " +15 " VBATF2 Vehicle SPU                |
| F-323   | 10 A | " +15 " VBATF3 Vehicle SPU                |

|  |       | <i>Functions</i>                     |
|---|-------|--------------------------------------|
| F-324   | 10 A  | "+15" VBATF4 Vehicle SPU             |
| F-325   | 7.5 A | "+15" Transmission Control Unit      |
| F-326   | 5 A   | "+15" Damper sensor                  |
| F-327   | 5 A   | "+15" Hydraulic pump sensor          |
| F-328   | 5 A   | "+15" Chassis level sensor           |
| F-329   | 5 A   | "+15" Stabilizer extensometer sensor |
| F-330   | 5 A   | "+15" Stabilizer on ground sensor    |
| F-331   | 5 A   | Fog light                            |
| F-332   | 5 A   | DRL Light                            |
| F-333   | 15 A  | "+15" Cranking                       |
| F-334   | 5 A   | Road Light                           |
| F-335   | 5 A   | Road Light                           |
| F-336   | 7.5 A | High beam                            |
| F-337   | 7.5 A | Low beam                             |
| F-338   | 5 A   | Stop light                           |
| F-339   | 5 A   | Reverse light                        |
| F-340   | 5 A   | "+30" VBATP Slave SPU                |
| F-341   | 5 A   | "+15" VE transmission TCU            |
| F-342   | 15 A  | "+30" VP transmission TCU            |
| F-343   | 10 A  | "+30" Main key                       |

### POWER BOX FUSE OF THE TELEHANDLER

Remove the panel (1) behind the step under the cab to access the fuse box and relays (2a - 2b).  
Remove the cap to access the fuse and relays.

** DANGER**

Always replace a faulty fuse with another of equivalent rating. Never use a fuse that has been.

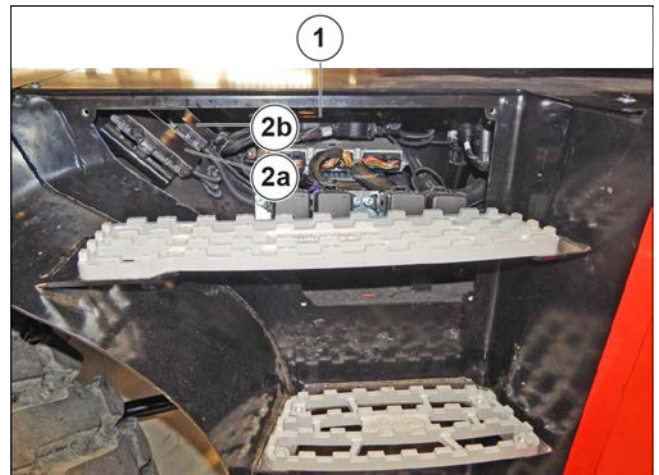

Figure 220: POWER BOX FUSE OF THE TELEHANDLER

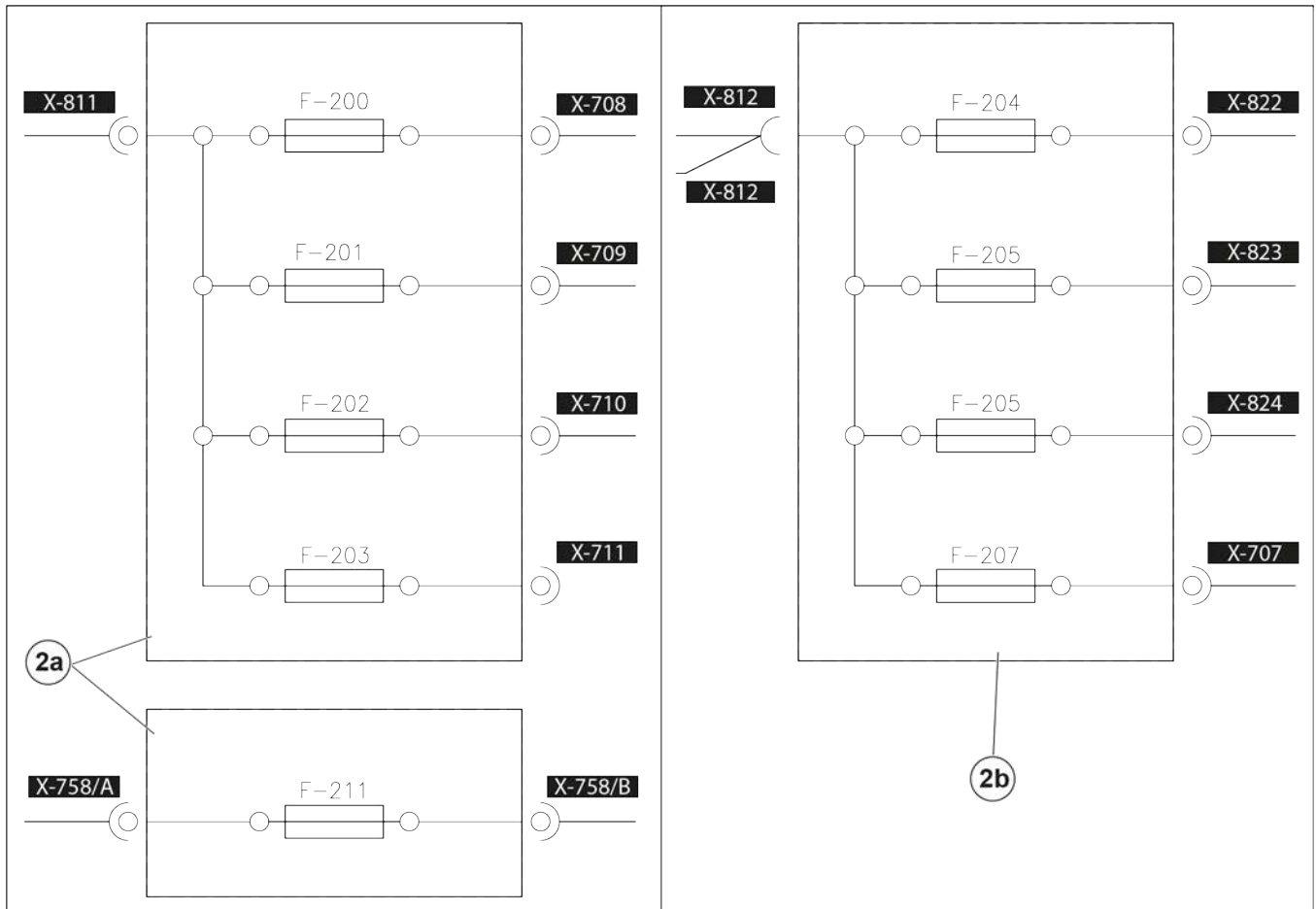



Figure 221: Overview of fuse and relays:

Table 104. Specification table of the fuses and relays on chassis

|  | <b>Functions</b> |                   |
|---|------------------|-------------------|
| <b>X-905</b>  |                  |                   |
| F-204   | 100 A            | Tower PWR         |
| <b>X-823</b>  |                  |                   |
| F-205   | 30 A             | Oil cooler fan 2  |
| <b>X-824</b>  |                  |                   |
| F-205   | 30 A             | Oil cooler fan 1  |
| <b>X-707</b>  |                  |                   |
| F-207   | 80 A             | Chassis PWR       |
| <b>X-708</b>  |                  |                   |
| F-200   | 30 A             | " +30" DCU        |
| <b>X-709</b>  |                  |                   |
| F-201   | 30 A             | " +30" Engine ECU |
| <b>X-710</b>  |                  |                   |
| F-202   | 40 A             | Glow plug         |
| <b>X-711</b>  |                  |                   |
| F-203   | -                | Available         |
| <b>X-758/B</b>  |                  |                   |
| F-211   | 50 A             | " +30" Unswitched |

### FUSE BOX AND RELAYS ENGINE

Remove the panel (1) behind the step under the cab for access to the fuse box and relays (2).  
Remove the cap to access the fuse and relays.

**⚠ DANGER**

Always replace a faulty fuse with another of equivalent rating. Never use a fuse that has been.

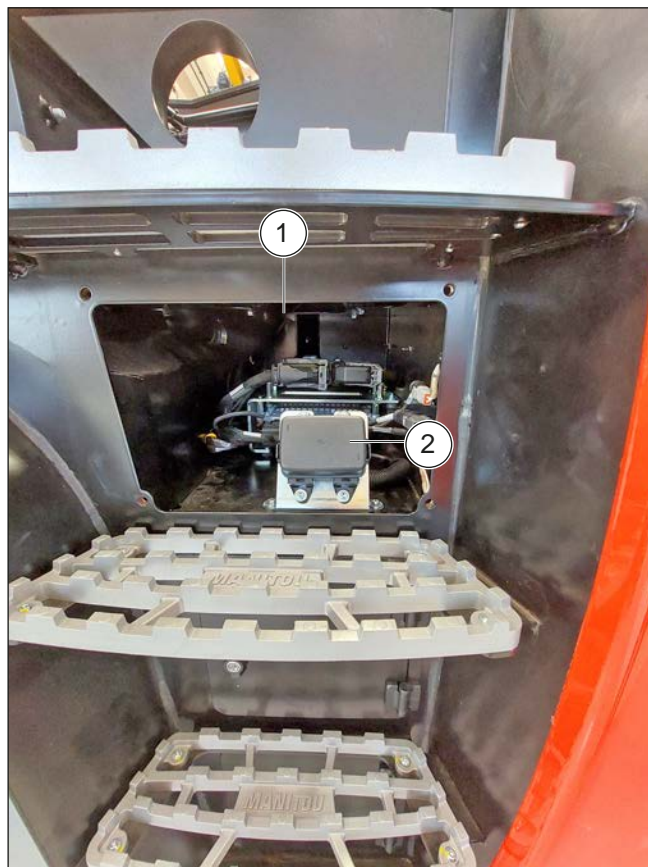

Figure 222: Fuse box and relays engine

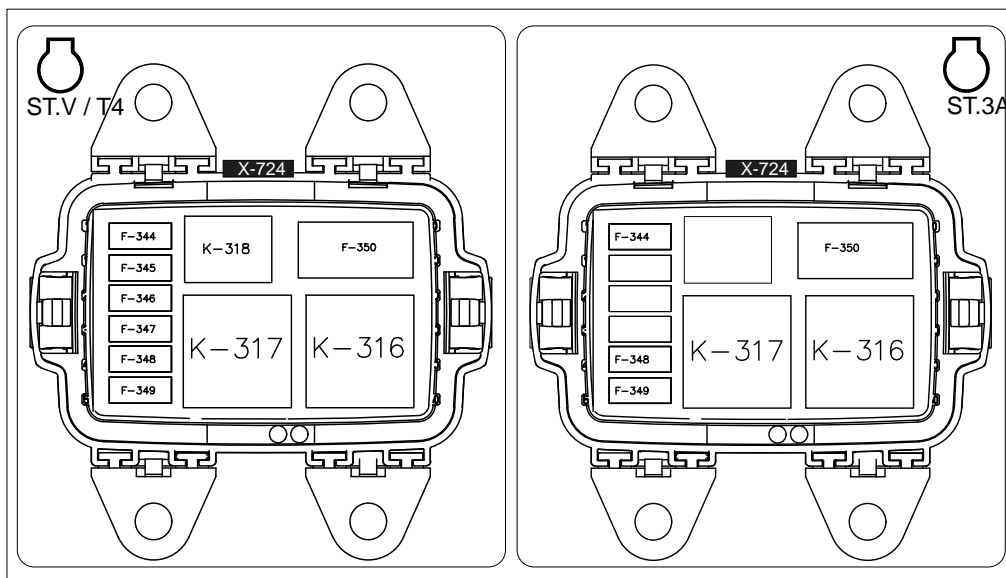



Figure 223: Overview of fuse and relays:

Table 105. Specification table of the fuse box and relays engine ST.V / T4

|  |     | <b>Functions</b>                      |
|---|-----|---------------------------------------|
| <b>X-724</b>  |     |                                       |
| F-344   | 5 A | Engine diagnostic plug / Battery hold |



|  |       | <i>Functions</i>      |
|---|-------|-----------------------|
| F-345   | 15 A  | DEF Heated pipe       |
| F-346   | 10 A  | NOx Sensors           |
| F-347   | 5 A   | DEF quality sensor    |
| F-348   | 5 A   | "+15" Alternator      |
| F-349   | 7.5 A | EGR valve             |
| F-350   | 20 A  | Fuel feed pump        |
| K-316   | 50 A  | Engine ECU main relay |
| K-317   | 50 A  | Glow plug relay       |
| K-318   | 15 A  | DEF heated pipe       |

Table 106. Specification table of the fuse box and relays engine ST.3A

|  |       | <i>Functions</i>                      |
|---|-------|---------------------------------------|
| <b>X-724</b>  |       |                                       |
| F-344   | 5 A   | Engine diagnostic plug / Battery hold |
| F-345   | -     | Available                             |
| F-346   | -     | Available                             |
| F-347   | -     | Available                             |
| F-348   | 5 A   | "+15" Alternator                      |
| F-349   | 7.5 A | EGR valve                             |
| F-350   | 20 A  | Fuel feed pump                        |
| K-316   | 50 A  | Engine ECU main relay                 |
| K-317   | 50 A  | Glow plug relay                       |
| K-318   | -     | Available                             |

#### 4.13.5 CHECK AND CLEANING OF THE TRANSMITTER RINGS OF THE ROTATING ELECTRIC COLLECTOR (AFTER 3 MONTHS OF INACTIVITY)

** DANGER**

Raise the boom and place the safety wedge on the rod of the lifting cylinder.

\* Contact your agent or dealer.



Figure 224: Check and cleaning of the transmitter rings of the rotating electric collector

#### 4.13.6 REMOTE CONTROL CHECK

Routine daily maintenance

Before starting work:

- Make sure that the housing and battery contacts are always clean.
- Check that the gaskets, bellows and caps of the actuators (joysticks, selectors and buttons) are intact, soft and elastic.
- Check that the symbols on the transmitter unit panel are clearly visible and replace the panel if necessary.
- Check the legibility and integrity of the three nameplates on the transmitter unit.
- Check the correct mechanical operation of the STOP button.

During normal operation:

- Check that the transmitter unit is structurally intact.
- Make sure that no materials (e.g. cement, sand, lime, dust) are deposited on the transmitter unit that could compromise its use and safety.

After using the remote control:

- Clean the transmitter unit: never use solvents or flammable/corrosive products and do not use high pressure cleaners or steam cleaners.
- Store the transmitter unit in a clean and dry environment.

### Routine quarterly maintenance

Every 3 months:

- Remove dust or other buildup of material from the receiving unit.
- To clean, never use solvents or flammable/corrosive products and do not use high pressure cleaners or steam cleaners.
- Check that the receiving unit is structurally intact.
- Check the integrity and connection of the receiving unit wiring.
- Check that the symbols on the receiving unit panel are clearly visible and replace the panel if necessary.
- Check the readability and integrity of the plates of the receiving unit.

### Extraordinary maintenance

**⚠ DANGER**

Any faults can only be repaired by authorized personnel. (contact the MANITOU assistance service).

### Troubleshooting Guide

When the remote control does not work, it is necessary:

- to move the transmitting unit closer to the receiving unit in order to avoid noise and radio interference.

- to check if the problem affects the remote control or the machine. Therefore, before carrying out any checks, try to control the machine through a control station other than the remote control, if present.

If it persists, the problem affects the machine itself. Otherwise the problem concerns the remote control. In this case, refer to the paragraph "Malfunctions reported by the transmitter unit".

### MALFUNCTIONS REPORTED BY THE TRANSMITTER UNIT (Pushbutton panel)

Red LED and green LED.

The table below indicates the malfunctions that may be encountered when the LEDs present in the transmitter unit come on and the relative solutions.

If the problem persists after having implemented the indicated solution, contact the MANITOU assistance service.

Table 107. Malfunctions reported by the transmitter unit (Pushbutton panel)

| Reports  | Possible causes   | Solutions  |
|--|---|--|
| The green LED flashes quickly.<br>The red LED flashes for minutes.   | The battery is not sufficiently charged or the transmitter unit has been switched on for twenty-four hours. | It is necessary to replace the battery with a charged one or it is necessary to turn off the transmitter unit and restart the radio control. |
| The green LED repeats one or two flashes and a pause.<br>The red LED flashes for minutes.                                |   |  |
| The green LED repeats three flashes and a pause.<br>The red LED flashes for minutes.                                     | The transmitter unit has been on for twenty-four hours.   | It is necessary to switch off the transmitter unit and restart the radio control.  |
| The green LED is off.<br>The red LED flashes for a very long time.   | The transmitter unit is not working properly.   | Contact the MANITOU assistance service.  |
| When the remote control is started, the green LED is off and the red LED flashes for a long time.                        | The GSS or EMS button is pressed.   | Disengage the GSS or EMS button.   |
| When starting the remote control, the green LED is off and the red LED makes two long flashes.                           | The transmitter unit is not working properly.   | Contact the MANITOU assistance service.  |
| When the remote control is started, the green LED is off and the red LED makes three long flashes.                       | The battery is very low.  | You need to replace the battery with a charged one.  |
| When the remote control is started, the green LED is off and the red LED makes four long flashes.                        | The SAFETY command is active.   | Bring the actuators to rest position.<br>If this message persists, contact the MANITOU assistance service.                                   |
| When the remote control is started, the green LED is on and the red LED flashes for a long time and a few short flashes. | At least one of the actuators related to the digital commands is active.                                    | Bring the actuators to rest position. If this message persists, contact the MANITOU assistance service.                                      |
| When the remote control is started, the green LED is on and the red LED makes two long flashes and a few short flashes.  | At least one of the actuators related to the analog commands is active.                                     |  |
| When the remote control is started, the green LED is on and the red LED flashes three long and a few short flashes.      | At least one of the actuators related to the direction commands is active.                                  |  |
| When the remote control is started, the green LED is on and the red LED flashes four long and a few short flashes.       | At least one of the actuators related to the direction commands is active.                                  |  |

**MALFUNCTIONS REPORTED BY THE RECEIVING UNIT**





The table below indicates the malfunctions that may be encountered when the LEDs on the receiving unit turn on.

If the problem persists after having implemented the indicated solution, contact the MANITOU assistance service.

Table

Table 108. Malfunctions reported by the receiving unit

| Reports               | Possible causes                   | Solutions  |
|-----------------------|-----------------------------------|--|
| The POWER LED is off. | The receiving unit is turned off. | Check the integrity of the power supply protection fuse. |

|   |  |  |
|---|--|--|
|   |  | Connect the connection plug correctly and power up the receiver unit.  |
|    | There is an error on the STP_1 output.   | Check the integrity of the STP_1 output protection fuse.<br>Attach the connecting plug correctly.<br>Check the correct wiring of the STP_1 output.           |
|    | There is an error on the STP_2 output.   | Check the integrity of the STP_2 output protection fuse.<br>Attach the connecting plug correctly.<br>Check the correct wiring of the STP_2 output.           |
|    | There is an error on the SAF_1 output.   | Check the integrity of the SAF_1 output protection fuse (fuse F6).<br>Attach the connecting plug correctly.<br>Check the correct wiring of the SAF_1 output. |
|    | There is an error on the SAF_2 output.   | Check the integrity of the SAF_2 output protection fuse.<br>Attach the connecting plug correctly.<br>Check the correct wiring of the SAF_2 output.           |
| The STATUS LED flashes slowly.  | There is an overvoltage in the power supply.   | Check that the power supply of the receiving unit is within the voltage limits indicated in the technical data.  |
| The STATUS LED flashes intermittently fast.   | The receiving unit loses some of the data sent by the transmitting unit.   | Move the transmitting unit closer to the receiving unit.<br>If this message persists, contact Manitou Customer Service.                                      |
| The RUN LED flashes.  | The receiving unit does not send commands to the CAN network.  | Contact the MANITOU assistance service.  |
| The ERR LED flashes.  | There is a CAN communication error.  |  |
|  | The receiving unit has activated the automatic stop function (ATS) as it carries out a self-test every twenty-four hours of continuous ignition. | Start the remote control   |
| The SETUP LED flashes twice.  | There is a memory card error.  | Contact the MANITOU assistance service.  |

#### 4.13.7 CHECKING AND CLEANING THE FUEL TANK FILLER FILTER

1. Open the access door (1) on the fuel filler cap (2) (3) and unscrew it.
2. Unlock and remove the fuel filter (4) from the filler (3).
3. Clean it with an air jet, check that it is not damaged and if necessary replace it with a new one.
4. Refit the filter (4) and screw the cap (2) back on.

5. Close the access door (1).

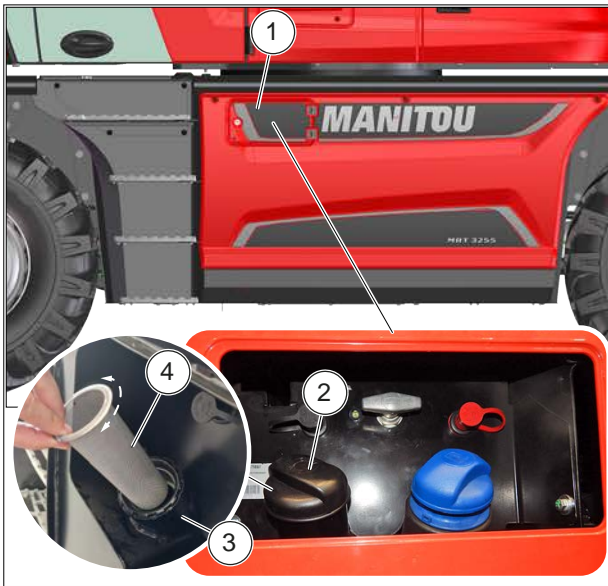

Figure 225: Checking and cleaning the fuel tank filler filter

#### 4.13.8 CHECKING AND CLEANING THE DEF TANK FILLER FILTER

1. Open the access door (1) to the DEF filler cap (2) and unscrew it.
2. Unlock and remove the fuel filter (4) from the filler (3).
3. Clean it with an air jet, check that it is not damaged and if necessary replace it with a new one.
4. Refit the filter (4) and screw the cap (2) back on.
5. Close the access door (1).





Figure 226: Checking and cleaning the DEF tank filler filter

#### 4.13.9 STATIONARY REGENERATION OF DPF FILTER "HANDLER STOPPED"

**⚠ DANGER**

DPF regeneration is an automated procedure, which is initiated by the operator when the following lights flash:



 or  +  after 50 hours of operation with an engine speed reduction of 25%.

Park the telehandler in a safe and sufficiently ventilated place.

To perform the regeneration, the system that controls the devices and actions of the exhaust gas after-treatment of the telehandler will check that the following conditions are met:

- Neutral gear selector.
- Parking brake applied.
- No movement operated (telescopic boom, stabilizers, leveling).
- Telescopic boom in transport position (low and retracted).
- Accelerator pedal released.
- Manual throttle at idle.

Check that the fuel level is sufficient. Start the telehandler and run the three-phase motor for a few minutes to bring it to operating temperature (60° C - 140° F).

Press the button for more than two seconds  to start the automated DPF regeneration procedure. The button lights up (yellow or blue) to indicate that the automated procedure has been activated. An amber indicator lights up on the display . Follow the steps indicated on the information display.

**⚠ DANGER**

The DPF regeneration procedure should only be interrupted if necessary. The procedure stops automatically if the operator: Operate the joysticks of the hydraulic movements. Operate the forward or reverse direction selector. Turns off

the three-phase motor. Press the button .

## 5. REFERENCES, OPTIONS AND ACCESSORIES

### 5.1. REFERENCES

#### 5.1.1 LUBRICANTS AND FUEL

#### **⚠ DANGER**

USE RECOMMENDED LUBRICANTS AND FUEL:

For topping up, not all oils are mixable.

For gearboxes, MANITOU oils are perfectly suited.

#### DIAGNOSTIC ANALYSIS OF OILS

In the event of an inspection or maintenance contract concluded with the dealer, a diagnostic analysis of the engine, transmission and axle oils may be required, depending on the utilization rate.

#### CHARACTERISTICS OF THE FUEL REQUIRED

Use a quality fuel to obtain the optimum performance of the internal combustion engine.

- Type of diesel fuel EN590 (sulfur rate <10 ppm).
- ASTM D975 diesel fuel type (sulfur rate <15 ppm).

#### "DEF" SPECIFICATIONS (Diesel Emissions Additive)

- Aqueous solution of urea at 32.5% (ISO22241).
- Solidification at -11° C and expansion of 10%.
- Flammable product.
- Thermal degradation (> 60° C).
- Storage between -5° C and 30° C.

#### **⚠ WARNING**

#### Risk of corrosive substances

Corrosive product for metals; it is necessary to wear personal protective equipment (gloves and protective goggles).

#### CAPACITY and RECOMMENDED PRODUCTS MRT 2260, MRT-X 2260, MRT 2660, MRT-X 2660

Table 109. Recommended capacities and products MRT 2260 - 2660 & MRT-X 2260 - 2660

| COMPONENTS TO BE LUBRICATED                                | CAPACITY           | RECOMMENDED PRODUCT               |
|--|--------------------|-----------------------------------|
| <b>THREE-PHASE MOTOR</b>                                   |                    |                                   |
| THREE-PHASE MOTOR<br><b>MRT 2260 ST5 - MRT 2660 ST5</b>    | 13 L - 3.43 US gal | MANITOU EVOLOGY OIL 10W40 API CJ4 |
| THREE-PHASE MOTOR <b>MRT-X 2260 ST3A - MRT-X 2660 ST3A</b> |                    | MANITOU PREMIUM OIL 15W40 API CI4 |

| COMPONENTS TO BE LUBRICATED                    | CAPACITY                 | RECOMMENDED PRODUCT                          |
|--|--------------------------|--|
| COOLING SYSTEM                                 | 22 L - 5.8 US gal        | COOLING SYSTEM -35° C (Concentrated Product) |
| FUEL TANK                                      | 270 L - 71.32 US gal     | DIESEL                                       |
| TANK DEF<br><b>MRT 2260 ST5 - MRT 2660 ST5</b> | 24 L - 6.34 US gal       | "DEF" (diesel emissions fluid)               |
| <b>TRANSMISSION</b>                            |                          |  |
| GEARBOX  | 1.6 L - 0.42 US gal      | SPECIAL MANITOU OIL IMMERSSED BRAKES         |
| CARDAN JOINT                                   |                          | BLUE MULTIPURPOSE MANITOU GREASE             |
| <b>TELESCOPIC BOOM</b>                         |                          |  |
| TELESCOPIC BOOM SHOES                          |                          | WHITE GREASE BERULUB PAL 1 (NLGI 1)          |
| CHAIN LUBRICATION                              |                          | SPRAY OIL MANITOU SPECIAL CHAINS             |
| <b>HYDRAULICS</b>                              |                          |  |
| HYDRAULIC OIL TANK                             | 260 L - 68.7 US gal      | MANITOU ISO VG 46 HYDRAULIC OIL              |
| <b>CABIN</b>                                   |                          |  |
| WINDSCREEN WASHER FLUID TANK                   | 5 L - 1.3 US gal         | WINDSCREEN WASHING FLUID                     |
| FRONT AXLE                                     |                          |  |
| CENTRAL DIFFERENTIAL                           | 7 L - 1.84 US gal        | SPECIAL MANITOU OIL IMMERSSED BRAKES         |
| FINAL REDUCTIONS                               | 2.1 L - 0.55 US gal (x2) | SPECIAL MANITOU OIL IMMERSSED BRAKES         |
| FINAL REDUCTION PINS                           |                          | BLUE MULTIPURPOSE MANITOU GREASE             |
| AXLE OSCILLATION                               |                          | BLUE MULTIPURPOSE MANITOU GREASE             |
| <b>REAR AXLE</b>                               |                          |  |
| CENTRAL DIFFERENTIAL                           | 7.8 L - 1.71 US gal      | SPECIAL MANITOU OIL IMMERSSED BRAKES         |
| FINAL REDUCTIONS                               | 2 L - 0.4 US gal (x2)    | SPECIAL MANITOU OIL IMMERSSED BRAKES         |
| FINAL REDUCTION PINS                           |                          | BLUE MULTIPURPOSE MANITOU GREASE             |
| AXLE OSCILLATION                               |                          | BLUE MULTIPURPOSE MANITOU GREASE             |
| <b>CHASSIS</b>                                 |                          |  |
| ROTATION REDUCER SHAFT                         |                          | BLACK MULTIPURPOSE MANITOU GREASE            |
| ROTATION FIFTH WHEEL TOOTHING                  |                          | BLACK MULTIPURPOSE MANITOU GREASE            |

**CAPACITIES and RECOMMENDED PRODUCTS  
MRT 2570, MRT-X 2570, MRT 3060, MRT-X 3060**

Table 110. Recommended products and capacities MRT 2570, MRT-X 2570, MRT 3060, MRT-X 3060

| COMPONENTS TO BE LUBRICATED                     | CAPACITY             | RECOMMENDATIONS                       |
|---|----------------------|---------------------------------------|
| <b>ENGINE</b>                                   |                      |                                       |
| ENGINE <b>MRT 2570 ST5 - MRT 3060 ST5</b>       | 13 L - 3., 43 US gal | MANITOU EVOLOGY OIL 10W40 API CJ4     |
| ENGINE <b>MRT-X 2570 ST3A - MRT-X 3060 ST3A</b> |                      | MANITOU PREMIUM OIL 15W40 API CI4     |
| COOLING SYSTEM                                  | 22 L - 5.8 US gal    | COOLANT -35° C (Concentrated Product) |
| FUEL TANK                                       | 320 L - 84.5 US gal  | DIESEL                                |
| DEF TANK<br><b>MRT 2570 ST5 - MRT 3060 ST5</b>  | 24 L - 6.34 US gal   | "DEF" (diesel emissions fluid)        |
| <b>TRANSMISSION</b>                             |                      |                                       |

| COMPONENTS TO BE LUBRICATED   | CAPACITY                 | RECOMMENDATIONS                     |
|-------------------------------|--------------------------|-------------------------------------|
| GEARBOX                       | 1.6 L - 0.42 US gal      | SPECIAL MANITOU OIL IMMersed BRAKES |
| CARDAN JOINT                  |                          | BLUE MULTIPURPOSE MANITOU GREASE    |
| <b>TELESCOPIC BOOM</b>        |                          |                                     |
| TELESCOPIC BOOM SHOES         |                          | WHITE GREASE BERULUB PAL 1 (NLGI 1) |
| CHAIN LUBRICATION             |                          | SPRAY OIL MANITOU SPECIAL CHAINS    |
| <b>HYDRAULICS</b>             |                          |                                     |
| HYDRAULIC OIL TANK            | 300 L - 79.2 US gal      | MANITOU ISO VG 46 HYDRAULIC OIL     |
| <b>CABIN</b>                  |                          |                                     |
| WINDSCREEN WASHER FLUID TANK  | 5 L - 1.3 US gal         | WINDSCREEN WASHING FLUID            |
| <b>FRONT AXLE</b>             |                          |                                     |
| CENTRAL DIFFERENTIAL          | 7 L - 1.84 US gal        | SPECIAL MANITOU OIL IMMersed BRAKES |
| FINAL REDUCTIONS              | 2.1 L - 0.55 US gal (x2) | SPECIAL MANITOU OIL IMMersed BRAKES |
| FINAL REDUCTION PINS          |                          | BLUE MULTIPURPOSE MANITOU GREASE    |
| AXLE OSCILLATION              |                          | BLUE MULTIPURPOSE MANITOU GREASE    |
| <b>REAR AXLE</b>              |                          |                                     |
| CENTRAL DIFFERENTIAL          | 7.8 L - 2.06 US gal      | SPECIAL MANITOU OIL IMMersed BRAKES |
| FINAL REDUCTIONS              | 2 L - 0.5 US gal (x2)    | SPECIAL MANITOU OIL IMMersed BRAKES |
| FINAL REDUCTION PINS          |                          | BLUE MULTIPURPOSE MANITOU GREASE    |
| AXLE OSCILLATION              |                          | BLUE MULTIPURPOSE MANITOU GREASE    |
| <b>CHASSIS</b>                |                          |                                     |
| ROTATION REDUCER SHAFT        |                          | BLACK MULTIPURPOSE MANITOU GREASE   |
| ROTATION FIFTH WHEEL TOOTHING |                          | BLACK MULTIPURPOSE MANITOU GREASE   |

**CAPACITIES and RECOMMENDED PRODUCTS**  
**MRT 3570, MRT-X 3570, MRT 3570 ES, MRT-X 3570 ES**

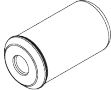

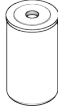

Table 111. Capacities and Recommended Products MRT 3570, MRT-X 3570, MRT 3570 ES, MRT-X 3570 ES









| COMPONENTS TO BE LUBRICATED                | CAPACITY            | RECOMMENDATIONS                       |
|--|---------------------|---------------------------------------|
| <b>ENGINE</b>                              |                     |                                       |
| ENGINE<br>MRT 3570 ST5 - MRT 3570 ES ST5   | 13 L - 3.43 US gal  | MANITOU EVOLOGY OIL 10W40 API CJ4     |
| ENGINE<br>MRT 3570 ST3A - MRT 3570 ES ST3A |                     | MANITOU PREMIUM OIL 15W40 API CI4     |
| COOLING SYSTEM                             | 22 L - 5.8 US gal   | COOLANT -35° C (Concentrated Product) |
| FUEL TANK                                  | 320 L - 84.5 US gal | DIESEL                                |
| DEF TANK<br>MRT 3570 ST5 - MRT 3570 ESST5  | 24 L - 6.34 US gal  | "DEF" (diesel emissions fluid)        |
| <b>TRANSMISSION</b>                        |                     |                                       |
| GEARBOX                                    | 2.7 L - 0.71 US gal | MANITOU DEXROM III OIL                |
| CARDAN JOINT                               |                     | BLUE MULTIPURPOSE MANITOU GREASE      |
| <b>TELESCOPIC BOOM</b>                     |                     |                                       |
| TELESCOPIC BOOM SHOES                      |                     | WHITE GREASE BERULUB PAL 1 (NLGI 1)   |
| CHAIN LUBRICATION                          |                     | SPRAY OIL MANITOU SPECIAL CHAINS      |

| COMPONENTS TO BE LUBRICATED   | CAPACITY                 | RECOMMENDATIONS                      |
|-------------------------------|--------------------------|--------------------------------------|
| <b>HYDRAULICS</b>             |                          |                                      |
| HYDRAULIC OIL TANK            | 300 L - 79.2 US gal      | MANITOU ISO VG 46 HYDRAULIC OIL      |
| <b>CABIN</b>                  |                          |                                      |
| WINDSCREEN WASHER FLUID TANK  | 5 L - 1.3 US gal         | WINDSCREEN WASHING FLUID             |
| <b>FRONT AXLE</b>             |                          |                                      |
| CENTRAL DIFFERENTIAL          | 21 L - 5.5 US gal        | SPECIAL MANITOU OIL IMMERSSED BRAKES |
| FINAL REDUCTIONS              | 1.8 L - 0.47 US gal (x2) | SPECIAL MANITOU OIL IMMERSSED BRAKES |
| FINAL REDUCTION PINS          |                          | BLUE MULTIPURPOSE MANITOU GREASE     |
| AXLE OSCILLATION              |                          | BLUE MULTIPURPOSE MANITOU GREASE     |
| <b>REAR AXLE</b>              |                          |                                      |
| CENTRAL DIFFERENTIAL          | 21 L - 5.5 US gal        | SPECIAL MANITOU OIL IMMERSSED BRAKES |
| FINAL REDUCTIONS              | 1.8 L - 0.47 US gal (x2) | SPECIAL MANITOU OIL IMMERSSED BRAKES |
| FINAL REDUCTION PINS          |                          | BLUE MULTIPURPOSE MANITOU GREASE     |
| AXLE OSCILLATION              |                          | BLUE MULTIPURPOSE MANITOU GREASE     |
| <b>CHASSIS</b>                |                          |                                      |
| ROTATION REDUCER SHAFT        |                          | BLACK MULTIPURPOSE MANITOU GREASE    |
| ROTATION FIFTH WHEEL TOOTHING |                          | BLACK MULTIPURPOSE MANITOU GREASE    |

## 5.1.2 FILTER ELEMENTS AND BELTS

Table 112. Filter elements and belts

| ELEMENT  | DESCRIPTION                                | OPERATION |
|--|--|-----------|
| <b>500H - PERIODIC MAINTENANCE - EVERY 500 HOURS OF OPERATION OR 6 MONTHS</b>  |  |           |
|   | Hydrostatic pump (transmission) oil filter | Replace   |
|   | Hydraulic oil filter cartridge (drain)     | Replace   |
|   | Hydraulic oil breather                     | Replace   |
| <b>1000H - PERIODIC MAINTENANCE - EVERY 1000 HOURS OF OPERATION OR 1 YEAR</b><br>(Also carry out periodic maintenance of the 500 hours of operation) |  |           |
|   | Engine oil filter                          | Replace   |
|   | Dry air filter cartridge                   | Replace   |

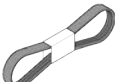
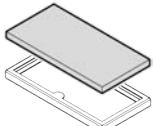
| ELEMENT  | DESCRIPTION                         | OPERATION     |
|--|-------------------------------------|---------------|
|   | Fuel pump filter                    | Check / Clean |
|   | Fuel filter                         | Replace       |
|   | Cabin ventilation filters           | Clean / Check |
|   |                                     |               |
|   | "DEF" fuel pump filter              | Replace       |
|    | "DEF" tank breather                 | Replace       |
| <b>2000H - PERIODIC MAINTENANCE - EVERY 2000 HOURS OF OPERATION OR 2 YEARS</b><br>(Also perform periodic maintenance of 500 hours and 1000 hours of operation) |                                     |               |
|   | Hydraulics intake filter cartridges | Clean         |
|   |                                     |               |
| <b>3000H - PERIODIC MAINTENANCE - EVERY 3000 HOURS OF OPERATION OR 3 YEARS</b><br>(Also perform periodic maintenance of 500 hours and 1000 hours of operation) |                                     |               |
|   | Air filter safety cartridge         | Replace       |
|   | Three-phase motor service belt      | Replace       |
| <b>4500H - PERIODIC MAINTENANCE - EVERY 4500 HOURS OF OPERATION OR 9 YEARS</b> (Also carry out periodic maintenance of the 500 hours of operation)             |                                     |               |
|   | Motor breather crankcase filter     | Replace       |

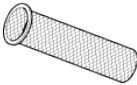
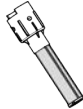
| ELEMENT   | DESCRIPTION             | OPERATION     |
|---|-------------------------|---------------|
| <b>OCCASIONAL MAINTENANCE</b>   |                         |               |
|  | Fuel tank filler filter | Check / Clean |
|  | DEF tank filler filter  | Check / Clean |

## 5.2. ATTACHMENTS

### 5.2.1 INTERCHANGEABLE EQUIPMENT AND MACHINE COMPATIBILITY

#### Interchangeable equipment

Interchangeable equipment or attachments are devices which, connected to the machine by the operator, modify the original function of the machine or add a new function. In the case of the telehandler, interchangeable equipment or attachments are for example (non-exhaustive list):

- the platform for lifting people or material,
- the jib & crane for handling suspended loads,
- the winch to lift material,
- etc.

Interchangeable equipment, if supplied by Manitou, is certified, i.e. it is equipped with a certificate of conformity that guarantees optimal safety for the operator and the machine.

#### **⚠ WARNING**

The use of interchangeable attachments or equipment not originally provided on the machine is prohibited.

In the event of subsequent requests for implementation of the machine functions with other attachments, the user, before commissioning, is obliged to request the suitability for use check by an authorized MANITOU technician, who will check the correct functioning and updating of the documentation necessary for the use of the new attachment. Only after this check will the authorization to use the new attachment be issued.

#### Interchangeable equipment compatible with the machine

The following tables show the list of interchangeable equipment or attachments compatible with each machine model.

Interchangeable equipment is identified by a code and a description, both reported on the metal plate of the equipment itself.

The compatibility between machine and attachment is certified by Manitou for interchangeable attachments for which the "V" sign appears in the box relating to the machine model.

Compatibility between machine and attachment is NOT guaranteed by Manitou for interchangeable attachments for which the "X" sign appears in the box relating to the machine model. This equipment should not be used on the specified machine model.

#### **⚠ WARNING**

Only attachments approved and certified by MANITOU can be used on telehandlers. The manufacturer's liability will not be involved in the event of modification or use of attachments made without its knowledge.

Use original attachments listed in the machine - attachment or equipment compatibility tables.

If in doubt, contact your dealer.

### Machine compatibility table - attachment: Forks carriage

| Image | Description   | Code (PN) | MRT Vision + |        |       |       |       |          |
|-------|---|-----------|--------------|--------|-------|-------|-------|----------|
|       |   |           | 22-60        | 26-060 | 25-70 | 30-60 | 35-70 | 35-70-ES |
|       | CAT1320/6T F.FEM4B100X60X1200                               | 52718348  | V            | V      | V     | X     | X     | X        |
|       | CAT1320/6T F.FEM4B100X60X1500                               | 52718356  | V            | V      | V     | X     | X     | X        |
|       | CAT1320/6T F.FEM4B100X60X1800                               | 52718357  | V            | V      | V     | X     | X     | X        |
|       | CAT1320/7T F.FEM4B150X60X1200                               | 52655420  | X            | X      | X     | V     | V     | V        |
|       | CAT1320/7T F.FEM4B150X60X1500                               | 52718373  | X            | X      | X     | V     | V     | V        |
|       | CAT1320/7T F.FEM4B150X60X1800                               | 52718374  | X            | X      | X     | V     | V     | V        |
|       | CAT1750/7T F.FEM4B150X60X1200                               | 52655520  | V            | V      | V     | V     | V     | V        |
|       | CAT1750/7T F.FEM4B150X60X1500                               | 52718375  | V            | V      | V     | V     | V     | V        |
|       | CAT1750/7T F.FEM4B150X60X1800                               | 52718377  | V            | V      | V     | V     | V     | V        |
|       | CAT2000/7T F.FEM4B150X60X1200                               | 52655525  | V            | V      | V     | V     | V     | V        |
|       | CAT2000/7T F.FEM4B150X60X1500                               | 52718378  | V            | V      | V     | V     | V     | V        |
|       | CAT2000/7T F.FEM4B150X60X1800                               | 52718379  | V            | V      | V     | V     | V     | V        |
|       | PFB +TDL 4900kg L1320 SS DOSS +FOURCHES FEM3A 150x50x1200   | 921241    | V            | V      | V     | V     | V     | V        |
|       | PFB + TDL 4900kg L1320 + FOU-150X50X1500 FEM3A              | 921513    | V            | V      | V     | V     | V     | V        |
|       | PFB + TDL 4900kg L1320 SS DOSS + FOURCHES 150X50X2000 FEM3A | 921514    | V            | V      | V     | V     | V     | V        |
|       | CAT2000/7T SS F.4B150X60X1200                               | 52712870  | V            | V      | V     | V     | V     | V        |
|       | CAT2000/7T SS F.4B150X60X1500                               | 52719378  | V            | V      | V     | V     | V     | V        |
|       | CAT2000/7T SS F.4B150X60X2000                               | 52719379  | V            | V      | V     | V     | V     | V        |
|       | CAF1030/6T F100X60X1200 B                                   | 52658467  | V            | V      | V     | X     | X     | X        |
|       | CAF1030/6T F100X60X1500 B                                   | 52719487  | V            | V      | V     | X     | X     | X        |
|       | CAF1030/6T F100X60X1800 B                                   | 52719488  | V            | V      | V     | X     | X     | X        |
|       | CAF1030/7T F125X60X1200 B                                   | 52676010  | X            | X      | X     | V     | V     | V        |
|       | CAF1030/7T F125X60X1500 B                                   | 52719444  | X            | X      | X     | V     | V     | V        |
|       | CAF1030/7T F125X60X1800 B                                   | 52719446  | X            | X      | X     | V     | V     | V        |
|       | CAF1800/7T F125X60X1200 B                                   | 52701150  | V            | V      | V     | V     | V     | V        |
|       | CAF1800/7T F125X60X1500 B                                   | 52719494  | V            | V      | V     | V     | V     | V        |
|       | CAF1800/7T F125X60X1800 B                                   | 52719495  | V            | V      | V     | V     | V     | V        |
|       | TFF L1030 +TDL 5000kg +FOU-150X60X1200                      | 923956    | V            | V      | V     | V     | V     | V        |
|       | TFF CN+FOU-O 150X60X1200 4.9T                               | 921240    | V            | V      | V     | V     | V     | V        |
|       | CAT1200/4000 R B  | 53026525  | V            | V      | V     | V     | V     | V        |
|       | PFB FEM2A ORH +/-90° 1.5T +FOU                              | 923348    | V            | V      | V     | V     | V     | V        |

### Machine compatibility table - attachment: Baskets for materials

| Image | Description                   | Code (PN) | MRT Vision + |        |       |       |       |          |
|-------|-------------------------------|-----------|--------------|--------|-------|-------|-------|----------|
|       |                               |           | 22-60        | 26-060 | 25-70 | 30-60 | 35-70 | 35-70-ES |
|       | PANIER DOORS OUTILS           | 923311    | V            | V      | V     | V     | V     | V        |
|       | MATERIAL BASKET 2X1.2M 1000KG | 52596600  | V            | V      | V     | V     | V     | V        |

**Machine - attachment compatibility table:  
Lifting platforms**

| Image | Description                | Code (PN) | MRT Vision + |        |       |       |       |          |
|-------|----------------------------|-----------|--------------|--------|-------|-------|-------|----------|
|       |                            |           | 22-60        | 26-060 | 25-70 | 30-60 | 35-70 | 35-70-ES |
|       | PF 1200/200                | 52719244  | V            | V      | V     | V     | V     | V        |
|       | PF 2000/365                | 52719245  | V            | V      | V     | V     | V     | V        |
|       | PS 2000/365                | 52719246  | V            | V      | V     | V     | V     | V        |
|       | PSE 4200/365 ALUREACH      | 52719247  | V            | V      | V     | V     | V     | V        |
|       | PSE 4400/365               | 52719248  | V            | V      | V     | V     | V     | V        |
|       | PSE 4400 / 365D            | 52686224  | V            | V      | V     | V     | V     | V        |
|       | PSE 4400 / 365DD           | 52719250  | V            | V      | V     | V     | V     | V        |
|       | PSE 4400/700D              | 52719251  | V            | V      | V     | V     | V     | V        |
|       | PSE 4400 / 1000D           | 52619610  | V            | V      | V     | V     | V     | V        |
|       | PSE 5000 / 365D            | 52719253  | V            | V      | V     | V     | V     | V        |
|       | PSE 5000 / 1000D           | 52719254  | V            | V      | V     | V     | V     | V        |
|       | PSE 6000 / 365D            | 52719255  | V            | V      | V     | V     | V     | V        |
|       | PSE 4000 / 600D W300 / 41M | 52719257  | V            | V      | V     | V     | V     | V        |
|       | PSE 4000 / 450D W450 / 35M | 52719258  | V            | V      | V     | V     | V     | V        |
|       | PSR 2400/365               | 52719259  | V            | V      | V     | V     | V     | V        |
|       | PSR 2400/1000              | 52719260  | V            | V      | V     | V     | V     | V        |
|       | PSR 2300 / 1000F           | 52719261  | V            | V      | V     | V     | V     | V        |
|       | PST 1800/1000 FOPS1        | 52719262  | V            | V      | V     | V     | V     | V        |
|       | PST 3000/1000              | 52719263  | V            | V      | V     | V     | V     | V        |
|       | PSE 4000/365D R            | 52719264  | V            | V      | V     | V     | V     | V        |
|       | PFE 4000/1000FD            | 52719265  | V            | V      | V     | V     | V     | V        |
|       | PSE 4000/700FD             | 52719266  | V            | V      | V     | V     | V     | V        |
|       | PSR 3300 / 1000F           | 52719267  | V            | V      | V     | V     | V     | V        |
|       | PAJ1 2500/300              | 52719268  | V            | V      | V     | V     | V     | V        |
|       | PAJ2 1200/200              | 52719269  | V            | V      | V     | V     | V     | V        |
|       | P3D 1000/200 L7500         | 52719270  | V            | V      | V     | V     | V     | V        |
|       | PF 2000/365                | 52719658  | V            | V      | V     | V     | V     | V        |
|       | PSE 4400/365               | 52719665  | V            | V      | V     | V     | V     | V        |
|       | PSE 4400/700D              | 52719668  | V            | V      | V     | V     | V     | V        |
|       | PSE 4400/1000D             | 52719669  | V            | V      | V     | V     | V     | V        |
|       | PSE 5000/1000D             | 52719670  | V            | V      | V     | V     | V     | V        |
|       | P3D 1000/200 L7500         | 52719672  | V            | V      | V     | V     | V     | V        |
|       | PS 3000/600D W300/41M      | 52719256  | V            | V      | V     | V     | V     | V        |

**Machine - attachment compatibility table:  
Arms**

| Image | Description               | Code (PN) | MRT Vision + |        |       |       |       |          |
|-------|---------------------------|-----------|--------------|--------|-------|-------|-------|----------|
|       |                           |           | 22-60        | 26-060 | 25-70 | 30-60 | 35-70 | 35-70-ES |
|       | HBB 1500-2400             | 931627    | V            | V      | V     | V     | V     | V        |
|       | JE 6000/ 600              | 939995    | V            | V      | V     | V     | V     | V        |
|       | PC 50- frame-mounted hook | 921335    | V            | V      | V     | V     | V     | V        |
|       | PC 60- frame-mounted hook | 939050    | V            | V      | V     | V     | V     | V        |
|       | PC 90- frame-mounted hook | 939970    | V            | V      | V     | V     | V     | V        |
|       | P 600- extension jib      | 921316    | V            | V      | V     | V     | V     | V        |

| Image | Description           | Code (PN) | MRT Vision + |        |       |       |       |          |
|-------|-----------------------|-----------|--------------|--------|-------|-------|-------|----------|
|       |                       |           | 22-60        | 26-060 | 25-70 | 30-60 | 35-70 | 35-70-ES |
|       | P 1000- extension jib | 921317    | V            | V      | V     | V     | V     | V        |
|       | P 1500- extension jib | 921319    | V            | V      | V     | V     | V     | V        |
|       | P 2000- extension jib | 921320    | V            | V      | V     | V     | V     | V        |
|       | P 4000- 2-hook jib    | 921321    | V            | V      | V     | V     | V     | V        |
|       | P 6000- 2-hook jib    | 921322    | V            | V      | V     | V     | V     | V        |
|       | P 9000- 3-hook jib    | 930830    | V            | V      | V     | V     | V     | V        |

### Machine - attachment compatibility table: Winches

| Image | Description     | Code (PN) | MRT Vision + |        |       |       |       |          |
|-------|-----------------|-----------|--------------|--------|-------|-------|-------|----------|
|       |                 |           | 22-60        | 26-060 | 25-70 | 30-60 | 35-70 | 35-70-ES |
|       | JW4100/ 600 68M | 52719496  | V            | V      | V     | V     | V     | V        |
|       | J4100 W1000/34M | 52719497  | V            | V      | V     | V     | V     | V        |
|       | JW 1950 LBS     | 52718275  | V            | V      | V     | V     | V     | V        |
|       | J3000 W1500/43M | 52717710  | V            | V      | V     | V     | V     | V        |
|       | J2500 W2000/22M | 52718250  | V            | X      | X     | X     | X     | X        |
|       | J2500 W2000/35M | 52717582  | X            | V      | V     | V     | V     | V        |
|       | JE7000 W800/39M | 52717860  | V            | V      | V     | V     | V     | V        |
|       | W3000/23M       | 52718245  | V            | X      | X     | X     | X     | X        |
|       | W3000/36M       | 52717650  | X            | V      | V     | V     | V     | V        |
|       | W3000 DI /48M   | 52717900  | V            | V      | V     | V     | V     | V        |
|       | W6000/25M       | 52717140  | V            | X      | X     | V     | X     | X        |
|       | W6000/32M       | 52717351  | X            | V      | V     | X     | V     | V        |
|       | Variowinch 7.2t | 52576737  | V            | V      | V     | V     | V     | V        |

### Machine - attachment compatibility table: Buckets / Loaders

| Image | Description        | Code (PN) | MRT Vision + |        |       |       |       |          |
|-------|--------------------|-----------|--------------|--------|-------|-------|-------|----------|
|       |                    |           | 22-60        | 26-060 | 25-70 | 30-60 | 35-70 | 35-70-ES |
|       | CBR 1000 L2450     | 921282    | V            | V      | V     | V     | V     | V        |
|       | CBR 1000 L2450     | 923967    | V            | V      | V     | V     | V     | V        |
|       | CBA 1500 LDR L2450 | 921279    | V            | V      | V     | V     | V     | V        |
|       | BB 500 MRT         | 52000642  | V            | V      | V     | V     | V     | V        |
|       | BBHG 500 MRT       | 52000643  | V            | V      | V     | V     | V     | V        |
|       | GL 600             | 52000528  | V            | V      | V     | V     | V     | V        |
|       | GL 600 H MRT       | 52553617  | V            | V      | V     | V     | V     | V        |

**Machine - attachment compatibility table:  
Centering handler jib & crane**

| <i>Image</i> | <i>Description</i> | <i>Code (PN)</i> | <i>MRT Vision +</i> |               |              |              |              |                 |
|--------------|--------------------|------------------|---------------------|---------------|--------------|--------------|--------------|-----------------|
|              |                    |                  | <i>22-60</i>        | <i>26-060</i> | <i>25-70</i> | <i>30-60</i> | <i>35-70</i> | <i>35-70-ES</i> |
|              | CLR 4000           | 52721819         | V                   | V             | V            | V            | V            | V               |

**Machine - attachment compatibility table:  
Tire gripper**

| <i>Image</i> | <i>Description</i> | <i>Code (PN)</i> | <i>MRT Vision +</i> |               |              |              |              |                 |
|--------------|--------------------|------------------|---------------------|---------------|--------------|--------------|--------------|-----------------|
|              |                    |                  | <i>22-60</i>        | <i>26-060</i> | <i>25-70</i> | <i>30-60</i> | <i>35-70</i> | <i>35-70-ES</i> |
|              | TH33/2000S         | 52721340         | V                   | V             | V            | V            | V            | V               |

For Support and Service, Contact Your Dealer

