



647861 EN-USM1 C012025

MLT 630 115D ST5 S1

OPERATOR'S MANUAL
(ORIGINAL MANUAL)

IMPORTANT

Carefully read and understand this instruction manual before using this machine.

It contains all information relating to operation, handling and equipment, as well as important recommendations to be followed.

This document also contains precautions for use, as well as information on the service and routine maintenance required to ensure the machine's continued reliability and safety of use.

WHENEVER YOU SEE THIS SYMBOL, IT MEANS:



PLEASE NOTE! BE CAREFUL! YOUR SAFETY, THAT OF OTHERS, OR THE SAFETY OF THE MACHINE IS AT RISK.

- This manual has been produced based on the equipment list and technical characteristics given at the time of its design.
- The machine's equipment level depends on the options chosen and the country of sale.
- Depending on the machine's options and the date of sale, certain equipment or functions described in this manual may not be present on this machine.
- Descriptions and figures are non-binding.
- MANITOU reserves the right to change its models and their equipment without being required to update this manual.
- The MANITOU network, consisting exclusively of qualified professionals, is available to answer all your questions.
- This manual is an integral part of the machine.
- It is to be kept in its storage location at all times for ease of reference.
- Give this manual to the new owner if the machine is resold.

1st EDITION

A032021

UPDATED

B112022 **0-0**
 1-1 – 1-34
 2-4 – 2-15 ; 2-34 ; 2-35
 3-9 ; 3-11 ; 3-36 ; 3-40 ; 3-41

24/04/2023 **1-1 – 1-32**

C012025 **0-0**
 1-1 – 1-34
 2-71
 3-9

The brochure and all its contents, including diagrams, are the proprietary and confidential intellectual property of Manitou BF and / or its subsidiaries ("Manitou Group"). Any reproduction, publication or dissemination of any part of the brochure without the express written authorization of Manitou Group is strictly prohibited. Any violation of this provision will subject the offending party to prosecution by Manitou Group to the fullest extent of the law. The logos and the company's visual identity are the property of Manitou Group and may not be used without the express written authorization of Manitou Group.

All trademarks, registered and unregistered, is and shall remain the property of Manitou BF or its respective owner.

Any reproduction, source code access, decompilation, modification, copy (other than backup copies), correction of errors, transmission or distribution of any software built into Manitou Group machines is strictly prohibited.

In the event that the measures above nevertheless prove essential to enable use of the software, in accordance with its destination, or to obtain the information required for interoperability with other software created independently, the user should contact Manitou Group in advance and Manitou may, at its sole discretion, take the necessary measures or give access to only the information strictly necessary for interoperability.

Any breach of these requirements is likely to constitute a counterfeiting offense subject to legal action by Manitou Group.

Connected Manitou Group machines are equipped with boxes that collect technical data on the machines (such as geo-tracking data or data on component operation). This data, which is organized, processed and enhanced by algorithms and expertise proprietary to Manitou Group, constitutes, in combination with other elements, independent or not, a protected database according to laws & regulations on IP purposes.

It is strictly forbidden to have access to all or part of this database and to use the data (including in the event of accidental access) without explicit prior authorization from Manitou Group. In the event that Manitou Group authorizes a Manitou Group machine user to access all or part of this database, Manitou Group, as producer of this database, cedes to the user only a right to personal, non-exclusive, non transferable use of the database, and only by access to an information technology platform hosted by a server owned or controlled by Manitou Group.

In any case, the following are strictly prohibited:

- any extraction, reproduction, representation, reuse through provision to the public, distribution, transfer, permanent or temporary, on any medium, by any means, and in any form whatsoever, of all or of a qualitatively or quantitatively substantial part of the contents of this database,*
- any extraction, reproduction, representation, reuse through provision to the public, distribution, transfer, repeated or systematic of qualitatively or quantitatively insubstantial parts of the content of the database during operations manifestly exceeding normal use of the database by the user of the machine for his own needs,*
- any use of means to bypass technical protection measures for databases or software source code embedded in the boxes, in keeping according to laws & regulations on IP purposes.*

The latest updated version in force and binding of this document is the version available on demand.

Only the electronic version is maintained.

MANITOU BF S.A. Public limited company with a board of directors.

Head office: 430 rue de l'Aubinière - 44150 Ancenis - France

Share capital: €39,548,949

Entered in the Nantes Trade and Companies Register under number 857 802 508.

Tel.: +33 (0) 2 40 09 10 11

www.manitou.com

1 - OPERATING AND SAFETY INSTRUCTIONS

2 - DESCRIPTION

3 - MAINTENANCE

4 - ATTACHMENTS

1 - OPERATING AND SAFETY INSTRUCTIONS

1 - OPERATING AND SAFETY INSTRUCTIONS

INSTRUCTIONS TO THE COMPANY MANAGER	1-4
THE SITE	1-4
THE OPERATOR	1-4
THE MACHINE	1-4
A - SUITABILITY OF THE MACHINE FOR THE TASK	1-4
B - ADAPTING THE MACHINE TO USUAL ENVIRONMENTAL CONDITIONS	1-4
C - MODIFYING THE MACHINE.	1-5
D - FRENCH ROAD TRAFFIC RULES.	1-5
E - MACHINE CAB PROTECTION.	1-5
INSTRUCTIONS	1-6
MAINTENANCE	1-6
INSTRUCTIONS FOR THE OPERATOR	1-8
FOREWORD	1-8
GENERAL INSTRUCTIONS	1-8
A - OPERATOR'S MANUAL.	1-8
B - AUTHORIZATION FOR USE IN FRANCE.	1-8
C - MAINTENANCE	1-8
D - TIRES	1-9
E - MODIFYING THE MACHINE.	1-9
F - LIFTING PEOPLE.	1-9
OPERATING INSTRUCTIONS UNLADEN AND LADEN	1-10
A - BEFORE STARTING UP THE MACHINE	1-10
B - AVAILABLE IN THE DRIVER'S CAB.	1-10
C - ENVIRONMENT	1-10
D - VISIBILITY	1-11
E - STARTING THE MACHINE	1-12
F - OPERATING THE MACHINE	1-12
G - STOPPING THE MACHINE.	1-14
H - DRIVING THE MACHINE ON THE PUBLIC HIGHWAY.	1-15
INSTRUCTIONS FOR HANDLING A LOAD	1-18
A - CHOICE OF ATTACHMENTS	1-18
B - WEIGHT OF LOAD AND CENTER OF GRAVITY	1-18
C - LONGITUDINAL STABILITY LIMITER AND WARNING DEVICE.	1-18
D - TRANSVERSE ATTITUDE OF THE MACHINE.	1-19
E - PICKING UP A LOAD ON THE GROUND	1-19
F - PICKING UP AND PUTTING DOWN A HIGH LOAD ON TIRES	1-20
G - PICKING UP AND PUTTING DOWN A HIGH LOAD ON STABILIZERS.	1-22
H - PICKING UP AND PUTTING DOWN A SUSPENDED LOAD.	1-24
I - TRAVELING WITH A SUSPENDED LOAD.	1-24
INSTRUCTIONS FOR USE AS A LOADER	1-25
A - LOADING	1-25
B - BACKFILLING.	1-25
INSTRUCTIONS FOR USING THE MOBILE ELEVATING WORK PLATFORM	1-26
A - AUTHORIZATION FOR USE	1-26
B - SUITABILITY OF THE PLATFORM FOR THE JOB	1-26
C - PROVIDED ON THE PLATFORM	1-26
D - USING THE PLATFORM.	1-27
E - ENVIRONMENT	1-28
F - MAINTENANCE	1-28
INSTRUCTIONS FOR USING THE RADIO-CONTROL	1-29
HOW TO USE THE RADIO-CONTROL.	1-29
PROTECTIVE DEVICES.	1-29

MACHINE MAINTENANCE INSTRUCTIONS **1-30**

GENERAL INSTRUCTIONS **1-30**

PLACING THE JIB SAFETY WEDGE **1-30**

FITTING THE WEDGE. 1-30

REMOVING THE WEDGE 1-30

FITTING THE WEDGE. 1-30

REMOVING THE WEDGE 1-30

MAINTENANCE **1-31**

MAINTENANCE LOGBOOK 1-31

LUBRICANT AND FUEL LEVELS **1-31**

HYDRAULICS **1-31**

ELECTRICITY **1-31**

WELDING ON THE MACHINE **1-31**

WASHING THE MACHINE **1-32**

TRANSPORTING THE MACHINE **1-32**

PROLONGED MACHINE SHUTDOWN **1-32**

INTRODUCTION **1-32**

PREPARATION OF THE MACHINE **1-32**

DEF (Diesel Exhaust Fluid) TANK **1-32**

PROTECTING THE ENGINE **1-33**

MACHINE PROTECTION **1-33**

RETURNING THE MACHINE TO SERVICE **1-33**

DISPOSING OF THE MACHINE **1-34**

RECYCLING OF MATERIALS **1-34**

METALS. 1-34

PLASTICS. 1-34

RUBBER. 1-34

GLASS. 1-34

ENVIRONMENTAL PROTECTION **1-34**

WORN OR DAMAGED PARTS 1-34

USED OIL. 1-34

USED BATTERIES 1-34

INSTRUCTIONS TO THE COMPANY MANAGER

THE SITE

Proper management of the machine's area of travel will reduce the risk of accidents:

- ground not unnecessarily uneven or obstructed,
- no excessive slopes,
- pedestrian traffic controlled, etc.

THE OPERATOR

- Only qualified, authorized personnel can use the machine. This authorization is given in writing by the appropriate person in the establishment where the machine is to be used and must be carried permanently by the operator.

⚠ IMPORTANT ⚠

Experience has shown that there are a number of inappropriate ways in which the machine might be operated. Such foreseeable misuse, of which the main examples are listed below, are strictly forbidden.

- The foreseeable abnormal behavior resulting from ordinary negligence, but not from any intentional misuse of the equipment.

- The reflex reactions of a person in the event of a malfunction, incident, fault, etc. during operation of the machine.

- Behavior resulting from application of the "principle of least effort" when performing a task.

- For certain machines, the foreseeable behavior of such persons as: apprentices, teenagers, handicapped persons, trainees tempted to drive a machine, operators tempted to operate a machine to win a bet, in competition or for their own personal experience.

The person in charge of the equipment must take these criteria into account when assessing whether or not a person will make a suitable driver.

THE MACHINE

A - SUITABILITY OF THE MACHINE FOR THE TASK

- MANITOU has ensured that this machine is suitable for use under the standard operating conditions defined in this operator's manual, with a **STATIC TEST COEFFICIENT OF 1.25** and a **DYNAMIC TEST COEFFICIENT OF 1**, as specified in harmonized standard **EN 1459** for variable reach machines.
- Before commissioning, the facility manager must make sure that the machine is appropriate for the work to be done, and perform certain tests (in accordance with applicable legislation).

B - ADAPTING THE MACHINE TO USUAL ENVIRONMENTAL CONDITIONS

⚠ IMPORTANT ⚠

Lubricants are filled in the factory for average climatic use, i.e.: -15°C to 35°C.

For operation under more severe climatic conditions, before starting up, drain all circuits then fill using lubricants suitable for the ambient temperatures.

The same applies to the coolant.

⚠ IMPORTANT ⚠

The machines are designed for outdoor use under normal atmospheric conditions and indoor use in suitably aerated and ventilated premises. It is prohibited to operate the machine in areas which presents a risk of fire or which are potentially explosive (e.g. refineries, fuel or gas depots, stores of flammable products, etc.).

Specialized equipment is available when operating in these areas (ask your dealer for information).

- Our machines are designed to be used within a temperature range of -18 °C to +43 °C.
- In addition to the standard equipment fitted on your machine, many options are available, such as: road lighting, stop lights, rotating beacon light, reverse lights, front worklight, rear worklight, lifting structure worklight, etc. (depending on machine model).
- The operator must take into account the operating conditions to specify the machine's signaling and lighting equipment. Consult your dealer.
- Take into account the climatic and atmospheric conditions of the operation site. Consult your dealer for the suitability of lubricants and frost protection.
- Take into account the fire risk associated with use in dusty and flammable conditions (e.g. straw, flour, sawdust, organic waste, etc.).
- A machine operating in an area without fire extinguishing equipment must be equipped with an individual extinguisher. Solutions exist, consult your dealer.

Our machines comply with Directive 2014/30/EU (2015/208/EU for our type-approved "TRACTOR" machines) concerning electromagnetic compatibility (EMC), (UK : Electromagnetic Compatibility Regulations 2016) and with the corresponding harmonized standard EN 12895. Their correct operation is no longer guaranteed if they are used within areas in which the electromagnetic fields exceed the limit specified by this standard (20 V/m).

- Directive 2002/44/EC requires company managers to not expose their employees to excessive vibration doses. There is no recognized code of measurement for comparing the machines of different manufacturers. The actual doses received cannot therefore be measured under actual operating conditions at the user's premises.
- The following are some tips for minimizing these vibration doses:
 - Select the most suitable machine and attachment for the intended use.
 - Adapt the seat adjustment to the operator's weight (**depending on machine model**) and maintain it in good condition, as well as the cab suspensions. Inflate the tires in accordance with recommendations.
 - The seat is an essential way of reducing the vibrations transmitted to the operator. In the event of seat replacement, please contact MANITOU.
 - Ensure that the operators adapt their operating speed to suit the conditions on site.
 - As far as possible, arrange the site in such a way as to provide a flat running surface and remove obstacles and harmful potholes.

C - MODIFYING THE MACHINE



Modifying the structure and settings of the various components of your machine (hydraulic pressure, taring of limiters, engine speed, sensors, addition of extra equipment, addition of counterweights, unapproved and unauthorized attachments, alarm systems, etc.) yourself is strictly prohibited. In this case, the manufacturer cannot be held responsible.

D - FRENCH ROAD TRAFFIC RULES

(or see current legislation in other countries)

- Only one EC declaration of conformity is issued. It must be kept in a safe place.
- The road traffic rules for the machines are subject to the provisions of the highway code, according to the following categories:
 - Construction machinery (MT range): public works vehicle not predominantly for use on roads (point 6.9 of Article R.311-1 of the French Highway Code). The machine must have a 25 disc displayed on the rear of the machine and an operating license plate.
 - Non-type-approved "Tractor" machinery for agricultural work: (point 6.2 of Article R.311-1 of the French Highway Code). The machine must be fitted with an operating license plate.
 - Type-approved "Tractor" machinery for agricultural work: Agricultural tractor type T1a (point 5.1.1 of Article R.311-1 of the French Highway Code). The machine must be licensed.

SPECIAL INSTRUCTIONS APPLICABLE TO TYPE-APPROVED "TRACTOR" MACHINES

- All approved machines are supplied with a "Tractor" certificate of compliance with Regulation 167/2013, to be retained by the owner, and a page of administrative details together with a CNIT number (national type approval code) for registration at the prefecture.
- The owner of the machine is responsible for carrying out the necessary procedures for obtaining the vehicle registration document within the time limit defined by the regulations.
- The operator must hold a category B driver's license, unless granted an exemption.
- The machine must be driven on the public highway in accordance with the instructions given in the manual supplied with the machine (Gross weight, Gross combination weight, towing load, axle loads, maximum speeds, etc. according to the type/version). The operator must be in possession of the machine's registration document.



When towing a trailer or agricultural equipment, the traveling speed of the machine is limited to 25 km/h.

In this case, a "25" disc must be affixed to the rear of the convoy.

E - MACHINE CAB PROTECTION

- All machines comply with standard ISO 3471 Roll-over Protective Structures (ROPS)
- All machines comply with standard ISO 3449 Falling-Object Protective Structures (FOPS) (Level I or II) (↖ 2 - DESCRIPTION OF STICKERS AND PLATES)
- The windows used on our machines comply with standard ECE-R43 Operator Protective Structures (OPS).
- Approved "TRACTOR" machines also comply with the regulations:
 - (appendix 1322/2014-OCDE Code 4).
 - (appendix 1322/2014-OCDE Code 10).



Structural damage or overturning, a modification, changes or a poorly executed repair can reduce the protective efficiency of the cab, canceling its compliance.

Do not perform welding or drilling on the cab structure.

Consult your dealer to determine the limits of this structure without canceling its compliance.

INSTRUCTIONS

- The operator's manual must always be in good condition, in the language of the operator and placed in the storage compartment provided.
- The operator's manual and any plates or stickers which are no longer legible or are damaged, must be replaced immediately.

MAINTENANCE

⚠ IMPORTANT ⚠

Refer to chapter: MACHINE MAINTENANCE INSTRUCTIONS.

⚠ IMPORTANT ⚠

Your machine must be periodically inspected to ensure its continued compliance.

The frequency of this inspection is defined by the legislation in force in the country in which the machine is used.

- Maintenance or repairs other than those detailed in Part: 3 - MAINTENANCE must be carried out by qualified personnel (consult your dealer) and in the necessary safety conditions to preserve the health of the operator and any third party.
- Example for France "The manager in charge of the establishment using a machine must open and maintain a maintenance log for each machine (order of March 2, 2004) and undergo a general periodic inspection every 6 months (order of March 1, 2004)".

INSTRUCTIONS FOR THE OPERATOR

FOREWORD

⚠ IMPORTANT ⚠

The risk of accident while using, servicing or repairing this machine can be reduced if you follow the safety instructions and preventive measures detailed in this instruction manual.

Failure to respect the safety and operating instructions, or the instructions for repairing or servicing your machine may lead to serious, even fatal accidents.

⚠ IMPORTANT ⚠

In order to reduce or prevent any danger with a MANITOU-approved attachment, follow the instructions in paragraph: 4 - ADAPTABLE ATTACHMENTS AVAILABLE ON THE RANGE: INTRODUCTION.

- Only the operations and maneuvers described in these operator's manual must be performed. The manufacturer cannot predict all possible risky situations. Consequently, the safety instructions given in the operator's manual and on the machine itself are not exhaustive.
- At all times, as an operator, you must envisage, within reason, the possible risk to yourself, to others or to the machine when you use it.
- The operator is responsible for the machine in all circumstances, regardless of whether he is present in the driver's cab.

GENERAL INSTRUCTIONS

A – OPERATOR'S MANUAL

⚠ IMPORTANT ⚠

Carefully read and understand this operator's manual before operating this machine.

- The operator's manual must always be in good condition, in the language of the operator and placed in the storage compartment provided.
- Any operations or maneuvers not described in the operator's manual are proscribed.
- Follow the safety advice and the instructions described on the machine's stickers.
- Familiarize yourself with the machine on the ground where it will be operated.
- You must replace the instruction manual, as well as any plates or stickers, if they are no longer legible or are missing or damaged.

B - AUTHORIZATION FOR USE IN FRANCE

(or see current legislation in other countries).

- Only qualified, authorized personnel can use the machine. This authorization is given in writing by the appropriate person in the establishment where the machine is to be used and must be carried permanently by the operator.
- The operator is not empowered to authorize the driving of the machine by another person.

C - MAINTENANCE

- If the operator sees that the machine is not in good working order or does not comply with the safety instructions, he must inform his manager of this immediately.
- The operator is prohibited from carrying out any repairs or adjustments himself, unless he has been trained for this purpose. He must keep the machine properly cleaned if this is his responsibility.
- The operator must carry out the daily maintenance (↩ 3 - MAINTENANCE) before using the machine in his place of work.
- The operator is responsible for deciding and adjusting the frequency and type of the cleaning needed to prevent the risk of fire ensuing from the build-up of flammable material(s). The operator should pay special attention to all the areas of the machine where these high-risk materials are likely to accumulate (e.g. engine compartment, under the lifting structure, above the axles, inside the chassis, etc.).

D - TIRES

⚠ IMPORTANT ⚠

Do not use the machine if the wheels are damaged or excessively worn, because this could put your own safety or that of others at risk, or cause damage to the machine.

- The operator must ensure tires are suitable for the nature of the ground (see contact surface with the ground for the tires in the chapter: 2 - DESCRIPTION: TIRES). Optional solutions are available, please consult your dealer.
 - SAND tires.
 - FARM tires.
 - Snow chains.
- The machine's four tires must be the same brand, the same dimensions, the same structure (radial or diagonal) and the same usage category (normal, snow or special), and must have the same degree of tread wear.
- In the event of tire replacement, use tires authorized by MANITOU that are the same type and dimensions. Using different tires voids the machine's type approval and you may be liable.
- If you are replacing just one of the machine's tires (e.g. because it is damaged), we recommend choosing a tire with the same degree of wear as the remaining tires so as not to damage the transmission's kinematic chain.

⚠ IMPORTANT ⚠

Do not use the machine if the tires are damaged or excessively worn, because this could put your own safety or that of others at risk, or cause damage to the machine itself.

The fitting of foam inflated tires is prohibited and is not guaranteed by the manufacturer unless with prior authorization.

E - MODIFYING THE MACHINE

- ⚠ INSTRUCTIONS TO THE COMPANY MANAGER: ⚠ C - MODIFYING THE MACHINE.

F - LIFTING PEOPLE

- The use of working equipment and load lifting attachments to lift people is:
 - either forbidden
 - or authorized exceptionally and under certain conditions (⚠ regulations in force in the country in which the machine is used).
- The pictogram posted at the operator station reminds you that:
 - Left-hand column
 - It is forbidden to lift people, with any kind of attachment, using a non PLATFORM-fitted machine.
 - Right-hand column
 - With a PLATFORM-fitted machine, people can only be lifted using platforms designed by MANITOU for this purpose.
- MANITOU sells equipment specifically designed for lifting people (OPTION PLATFORM-fitted machine; contact your dealer).

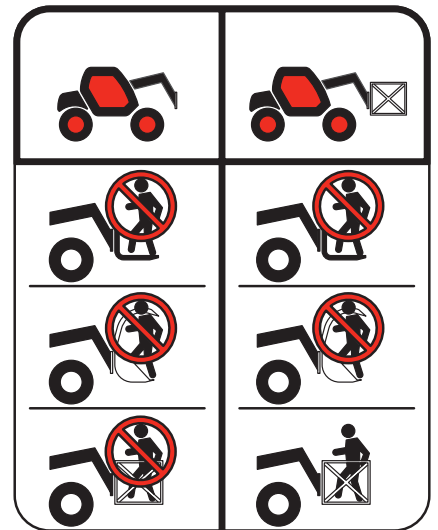

A - BEFORE STARTING UP THE MACHINE

- Perform the daily maintenance operations (< 3 - MAINTENANCE).
- Make sure that the driver's cab is clean, particularly the floor and floor mat. Check that no movable object may hinder the operation of the machine.
- Make sure the lights, turn signals and windshield wipers are working properly.
- Make sure the rear-view mirrors are in good condition, clean and properly adjusted.
- Make sure the horn works.

B - AVAILABLE IN THE DRIVER'S CAB

- Whatever his experience, the operator is advised to familiarize himself with the position and operation of all the controls and instruments before operating the machine.
- Wear clothes suitable for driving the machine, avoid loose clothing.
- Make sure you have the appropriate protective equipment for the task to be performed.
- Prolonged exposure to high noise levels may cause hearing problems. It is recommended to wear ear muffs to protect against excessive noise.
- Always face the driver's cab access when getting in and out of the lift truck and use the handle(s) provided for this purpose. Do not jump out of the machine.
- Remain alert at all times when using the machine. Do not listen to the radio or music using headphones or earphones.
- Never operate the lift truck when hands or feet are wet or soiled with greasy substances.
- For increased comfort, adjust the seat to your requirements and adopt the correct position in the driver's cab.



Under no circumstances must the seat be adjusted while the machine is moving.

- The operator must always be in his normal position in the driver's cab: Arms and legs, and generally any part of the body, should be kept inside the driver's cab of the machine.
- The safety belt must be worn and adjusted to the operator's size.
- The control units must never be used for any other than their intended purposes (e.g. Climbing onto or down from the machine, coat hanger, etc.).
- If the control components are fitted with a forced operation (lever lock) device, it is forbidden to leave the cab without first putting these controls in neutral.
- It is prohibited to carry passengers either on the machine or in the cab.

C - ENVIRONMENT

- Comply with site safety regulations.
- If you have to use the machine in a dark area or work at night, make sure it is equipped with work lights.
- During handling operations, make sure that no one is in the way of the machine and its load.
- Do not allow anybody to come near the working area of the machine or pass beneath an elevated load.
- The maximum slope on which the machine can be used in relation to the capacity of the brake is 20%.
- When using the lift truck on a transverse slope, before lifting the lifting structures, observe the instructions given in the paragraph: INSTRUCTIONS FOR HANDLING A LOAD: D - TRANSVERSE ATTITUDE OF THE MACHINE.
- Traveling on a longitudinal slope:
 - Drive and brake gently.

- Moving without load: Forks or attachment facing downhill.

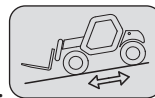

- Moving with load: Forks or attachment facing uphill.

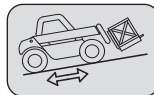

- Take into account the machine's dimensions and its load before trying to negotiate a narrow or low passageway.
- Never move onto a load bridge without having first checked:
 - That it is suitably positioned and made fast.
 - That the unit to which it is connected (wagon, truck, etc.) will not shift.
 - That this bridge is prescribed for the total weight of the machine, laden or unladen.
 - That this bridge is prescribed for the size of the machine.

- Never move onto a foot bridge, floor or freight lift, without being certain that they are suitable for the weight and size of the machine, laden or otherwise, and without having checked that they are in sound working order.
- Be careful in the area of loading bays, trenches, scaffolding, soft ground and manholes.
- Make sure the ground is stable and firm under the wheels and/or stabilizers before lifting or removing the load. If necessary, add appropriate wedging under the stabilizers.
- Make sure that the scaffolding, loading platform, pilings or ground is capable of bearing the load.
- Never stack loads on uneven ground, they may tip over.

⚠ IMPORTANT ⚠

If the load or the attachment must remain above a structure for a prolonged period of time, there is the risk that it will bear on the structure as the lifting structure descends due to cooling of the oil in the cylinders.

To eliminate this risk:

- Regularly check the distance between the load or the attachment and the structure and readjust this if necessary.

- If possible use the machine at an oil temperature as close as possible to ambient temperature.

- In the case of work near to overhead lines, ensure that the safety distance is sufficient between the machine's working area and the overhead line.

⚠ IMPORTANT ⚠

Do not operate this machine during thunderstorms, snowstorms, periods of frost, or in hazardous weather conditions.

⚠ IMPORTANT ⚠

You must consult your local electrical supplier.

You could be electrocuted or seriously injured if you operate or park the machine too close to power lines.

In the event of high winds, do not carry out handling work that jeopardizes the stability of the machine and its load, particularly if the load catches the wind badly.

- Prevent the fire risk associated with use in dusty and flammable conditions (e.g. straw, flour, sawdust, organic waste, etc.).

D - VISIBILITY

- The safety of people within the machine's working area, as well as that of the machine itself and the operator, are dependent on good operator visibility of the machine's immediate surroundings in all situations and at all times.
- This machine has been designed to allow good operator visibility (direct or indirect by means of rear-view mirrors) of the immediate surroundings of the machine while driving with no load and with the boom in the transport position.
- Special precautions must be taken if the size of the load restricts visibility towards the front:
 - moving in reverse,
 - site layout,
 - assisted by a person directing the operation (while standing outside the machine's area of travel), making sure to keep this person clearly in view at all times,
 - in any case, avoid reversing over long distances.
- Certain special accessories may require the machine to travel with the boom in the raised position. In such cases, visibility on the right hand side is restricted, and special precautions must be taken:
 - site layout,
 - assisted by a person directing the operation (while standing outside the machine's area of travel).
 - replacement of a suspended load by a load on a pallet.
- If visibility of your road is inadequate, ask someone to assist by directing the operation (while standing outside the machine's area of travel), making sure to keep this person clearly in view at all times.
- Keep all components affecting visibility in a clean, properly adjusted state and in good working order (e.g. windshields, windows, windshield wipers, windshield washers, driving lights and worklights, rear-view mirrors).

E - STARTING THE MACHINE

SAFETY INSTRUCTIONS

⚠ IMPORTANT ⚠

The machine must only be started up or maneuvered when the operator is sitting in the driver's cab with seat belt fastened and adjusted.

- Never try to start the machine by pushing or towing it. Such an operation may cause severe damage to the transmission. If necessary, towing requires the transmission to be put in neutral (↩ 3 - MAINTENANCE).
- If using an emergency battery for start-up, use a battery with the same characteristics and respect battery polarity when connecting it. Connect at first the positive terminals before the negative terminals.

⚠ IMPORTANT ⚠

Failure to respect polarity between batteries can cause serious damage to the electrical circuit.

The electrolyte in the battery may produce an explosive gas. Avoid flames and generation of sparks close to the batteries.

Never disconnect a battery while it is in charge.

INSTRUCTIONS

- Check the closing and locking of the hood(s).
- Check that the cab door is closed.
- Firmly press and hold down the brake pedal.
- Turn the ignition key to position (I) to switch on the machine and the engine preheat system.
- Check that the forward/reverse selector is in neutral, and that the manual parking brake is on.
- Check the fuel level on the dashboard gauge.
- Check the DEF (diesel exhaust fluid) level on the dashboard gauge. (depending on machine model)
- Turn the ignition key to position (III) for no longer than 15 seconds. The engine should then start. Release the ignition key and let the engine run at idling speed.
- Preheat the engine between each start attempt.
- Make sure all the signal lights on the control instrument panel are off.
- Check the longitudinal stability limiter and warning device (↩ 3 - MAINTENANCE).
- Do not use a machine that is non-compliant.
- Check all control instruments when the engine is warm and at regular intervals during use, so as to quickly detect any faults and to be able to correct them without any delay.
- If an instrument does not show the correct display, stop the engine and immediately carry out the necessary operations.

F - OPERATING THE MACHINE

SAFETY INSTRUCTIONS

⚠ IMPORTANT ⚠

We would like to draw the operators' attention to the risks involved in using the machine, in particular:

- Risk of losing control.

- Risk of loss of lateral and frontal stability of the machine.

The operator must remain in control of the machine.

In the event of the machine overturning, do not try to leave the cab during the incident.

YOUR BEST PROTECTION IS TO STAY FASTENED IN THE CAB.

- Observe the company's traffic regulations or, by default, the public highway code.
- Do not carry out operations which exceed the capacities of your machine or attachment.
- Always drive the machine with the forks or attachment in the transport position, i.e., 300 mm from the ground, the boom retracted and the forks carriage sloping backwards.
- Only carry loads which are balanced and properly anchored to avoid any risk of a load falling off.
- Ensure that pallets, cases, etc. are in good order and suitable for the load to be lifted.
- Familiarize yourself with the machine on the terrain where it will be used.
- Ensure that the brakes are working properly.
- The loaded machine must not travel at speeds in excess of 12 km/h.
- Drive smoothly at an appropriate speed for the operating conditions (land configuration, load on the machine).
- Do not use the hydraulic boom controls when the machine is moving.
- Never change the steering mode whilst driving.
- Ensure that visibility is adequate.
- Do not maneuver the machine with the boom in the raised position unless under exceptional circumstances and then with extreme caution, at very low speed and using gentle braking.
- Take bends slowly.

- In all circumstances make sure you are in control of your speed.
- On damp, slippery or uneven terrain, drive slowly.
- Brake gently, never abruptly.
- Only use the machine's forward/reverse selector from a stationary position and never do so abruptly.
- Do not drive with your foot on the brake pedal.
- Always remember that hydrostatic type steering is extremely sensitive to movement of the steering wheel, so turn it gently and not jerkily.
- Never leave the engine on when the lift truck is unattended.
- Do not leave the cab when the machine has a raised load.
- Look where you are going and always make sure you have good visibility along the route.
- Use the rear-view mirrors frequently.
- Drive around obstacles.
- Never drive on the edge of a ditch or steep slope.
- It is dangerous to use two machines simultaneously to handle heavy or bulky loads, since this operation requires particular precautions to be taken. It must only be used exceptionally and after risk analysis.
- The ignition switch has an emergency stop mechanism in case of an operating anomaly occurring in the case of machines not fitted with a punch-operated cut-out.

INSTRUCTIONS

- Always drive the machine with the forks or attachment in the transport position, i.e., 300 mm from the ground, the telescopic arm retracted and the forks carriage sloping backward.
- For machines with gearboxes, use the recommended gear (↩ 2 - DESCRIPTION: INSTRUMENTS AND CONTROLS).
- Select the steering mode appropriate for the use and/or working conditions (↩ 2 - DESCRIPTION: INSTRUMENTS AND CONTROLS) (depending on machine model).
- Deactivate the parking brake.
- Shift the forward/reverse selector to the selected direction of travel and accelerate gradually until the machine moves off.

⚠ IMPORTANT ⚠

Starting and moving the machine on a slope may be a real hazard.

If the machine is parked or stopped, adhere scrupulously to the following instructions for moving it:

- Press the brake pedal.

- Release the parking brake.

- Engage the appropriate gear. (depending on machine model)

- Select forward or reverse direction.

- Ensure that there is no one or anything impeding the movement of the machine.

- Release the brake pedal and accelerate the engine.

The use of the machine loaded or with a trailer increases the risk. In this case, remain extremely vigilant.

Each braking system operates independently.

In an emergency, use the brake pedal and/or the manual parking brake to immobilize the machine.

With the engine off, release the manual parking brake only after restarting the engine and making sure that the brake pedal is functional.

G - STOPPING THE MACHINE

SAFETY INSTRUCTIONS

- Never leave the ignition key in the machine during the operator's absence.
- When the machine is stationary, or if the operator has to leave his cab (even for a moment), place the forks or attachment on the ground, apply the parking brake and place the forward/reverse selector in neutral.
- Make sure that the machine is not stopped in any position that will interfere with the traffic flow and at less than one meter from the track of a railway.
- In the event of prolonged parking on a site, protect the machine from bad weather, particularly from frost (check the level of antifreeze), and close and lock all the machine accesses (doors, windows, cowls, etc.).

INSTRUCTIONS

- Park the machine on level ground.
- When parking on slopes of less than 15%, position the machine perpendicular to the slope.
- The slope must not exceed 15%.
- Press and hold the brake pedal.
- Set the forward/reverse selector to neutral.
- Activate the parking brake.
- Release the brake pedal.
- The machine must be stationary before leaving the driver's cab.
- Fully retract the telescopic arm.
- Lower the forks or attachment to rest on the ground.
- When using an attachment with a grab or jaws, or a bucket with hydraulic opening, close the attachment fully.
- Before stopping the machine after intensive work, leave the engine idling for a few moments to allow the coolant and oil to lower the temperature of the engine and transmission. Do not forget this precaution, in the event of frequent stops or warm stalling of the engine, or else the temperature of certain parts will rise significantly due to the stopping of the cooling system, with the risk of badly damaging such parts.
- Stop the engine with the ignition switch and remove the key.
- Lock all the openings to the machine (doors, windows, cowls, etc.).
- Turn the battery cut-off to the "OFF" position in accordance with the recommendations (↖ 2 - DESCRIPTION).

H - DRIVING THE MACHINE ON THE PUBLIC HIGHWAY

(or see current legislation in other countries)

FRENCH ROAD TRAFFIC RULES

- The driving of non-type-approved "Tractor" machines on the public highway is subject to the provisions of the French Highway Code relating to special machines, defined in Article R.311-1 of the French Highway Code, in category B of the Equipment Order of November 20, 1969, which determines the procedures applicable to special machines. The machine must be fitted with an operating license plate.
- The driving of type-approved "Tractor" machines on the public highway is subject to the provisions of the French Highway Code relating to agricultural tractors, defined in Article R.311-1 of the French Highway Code. The machine must be licensed.
- The machine must be driven on the public highway in accordance with the instructions given in the manual supplied with the machine (Gross weight, Gross combination weight, towing load, axle loads, maximum speeds, etc. according to the type/version). The operator must be in possession of the machine's registration document.
- The operator must hold an HGV license, unless granted an exemption.
- When towing a trailer or agricultural equipment, the travel speed of the machine is limited to 25 km/h. In this case, a "25" disc must be affixed to the rear of the convoy.

GERMAN ROAD TRAFFIC RULES

⚠ IMPORTANT ⚠

For machines with the "Allgemeine Betriebserlaubnis" (general operating permit or ABE, in accordance with Article 20 of the StVZO "Straßenverkehrs-Zulassungsordnung"), follow the instructions below:

- Disconnect the reversing sound alarm before using a machine with a general operating permit (ABE) on the public highway.

⚠ IMPORTANT ⚠

Always reconnect the sound alarm before handling on private roads.

- Before you use the machine for handling operations on private roads:
 - Make sure that the machine's reversing sound alarm is connected and working properly.
 - Perform a functional test by putting the machine into reverse gear.
 - The audible alarm sounds.
 - Do not use the machine if the audible alarm is not working. Check the audible alarm's connection and repeat the test. Consult your dealer if the problem persists.

SAFETY INSTRUCTIONS

- Operators driving on the public highway must comply with current highway code legislation.
- The machine must comply with current road legislation. If necessary, there are optional solutions. Contact your dealer.

INSTRUCTIONS

- Make sure the revolving light is in place, switch it on and verify its operation.
- Make sure the lights, turn signals and windshield wipers are working properly.
- Check the cleanliness of the machine's mudguards.
- Check the general cleanliness of the machine before driving on public roads.
- Switch off the worklights if the machine is fitted with them.
- Select the steering mode "HIGHWAY TRAFFIC" (↩ 2 - DESCRIPTION: INSTRUMENTS AND CONTROLS) (depending on machine model).
- Fully retract the telescopic arm and set the attachment approximately 300 mm off the ground.
- Put the frame leveling in the central position, i.e., the transverse axis of the axles parallel to the frame (depending on the machine model).
- Fully raise the stabilizers and turn the shoes inwards (depending on the machine model).

⚠ IMPORTANT ⚠

Never coast in neutral (forward/reverse selector or gear lever in neutral or transmission cut-off button pressed) to preserve the machine's engine brake.

Failure to observe this instruction on a slope will lead to excessive speed, which may make the machine uncontrollable (steering, brakes) and cause serious mechanical damage.

DRIVING THE MACHINE WITH A FRONT-MOUNTED ATTACHMENT

- You must comply with current regulations in your country, covering the possibility of driving on the public highway with a front-mounted attachment on your machine.
- If road legislation in your country authorizes circulation with a front-mounted attachment, you must at least:
 - Protect and report any sharp and/or dangerous edges on the attachment (↩ 4 - ADAPTABLE ATTACHMENTS AVAILABLE ON THE RANGE).
 - The attachment must not be loaded.
 - Make sure that the attachment does not mask the lighting range of the forward lights.
 - Make sure that current legislation in your country does not require other obligations.

OPERATING THE MACHINE WITH A TRAILER

- For using a trailer, observe the regulations in force in your country (maximum travel speed, braking, maximum weight of trailer, etc.).
- Do not forget to connect the trailer's electrical equipment to that of the machine.
- The trailer's braking system must comply with current legislation.
- If pulling a trailer with assisted braking, the tractor machine must be equipped with a trailer braking mechanism. In this case, do not forget to connect the trailer braking equipment to that of the machine.
- The vertical force on the towing hook must not exceed the maximum authorized by the manufacturer (consult the manufacturer's plate on your machine).
- The authorized gross vehicle weight must not exceed the maximum weight authorized by the manufacturer (↩ 2 - DESCRIPTION: SPECIFICATIONS).

IF NECESSARY, CONSULT YOUR DEALER.

INSTRUCTIONS FOR HANDLING A LOAD

A - CHOICE OF ATTACHMENTS

- Only attachments approved and authorized by MANITOU can be used on its machines.
- Make sure the attachment is suitable for the work to be done (◀ 4 - ADAPTABLE ATTACHMENTS AS OPTIONS ON THE RANGE).
- If the machine is equipped with the single sideshift attachment OPTION (TSDL), use only the authorized attachments (◀ 4 - ADAPTABLE ATTACHMENTS AS OPTIONS ON THE RANGE).
- Make sure the attachment is correctly installed and locked onto the machine carriage.
- Make sure that your machine attachments are working properly.
- Comply with the load chart limits for the machine for the attachment used.
- Do not exceed the rated capacity of the attachment.
- Never lift a slung load without the attachment provided for the purpose, as there is a risk of the sling slipping (◀ INSTRUCTIONS FOR HANDLING A LOAD: H - PICKING UP AND PUTTING DOWN A SUSPENDED LOAD).
- Do not handle loads suspended by straps directly on the forks (e.g.:big bags), as there is a risk of shearing on sharp edges. Use an attachment designed for this purpose.

B - WEIGHT OF LOAD AND CENTER OF GRAVITY

- Before picking up a load, you must know its weight and its center of gravity.
- The longitudinal position of the center of gravity in relation to the heel of the forks (Fig. B1) is defined on the load chart for your machine (◀ 2 - DESCRIPTION: DIMENSIONS AND LOAD CHARTS). For loads with center of gravity exceeding this distance, contact your dealer.
- For irregular loads, determine the transverse center of gravity before any handling (fig. B2) and set it in the longitudinal axis of the machine.

⚠ IMPORTANT ⚠

It is forbidden to handle a load heavier than the effective capacity defined on the machine load chart.

For loads with a moving center of gravity (e.g. liquids), take account of the variations in the center of gravity in order to determine the load to be handled and be extra vigilant and careful to limit these variations as far as possible.



C - LONGITUDINAL STABILITY LIMITER AND WARNING DEVICE

This device gives an indication of the longitudinal stability of the machine, and limits hydraulic movements in order to ensure this stability, at least under the following operating conditions:

- when the machine is at a standstill,
 - when the machine is on firm, stable and consolidated ground,
 - when the machine is performing handling and placing operations.
- Move the boom very carefully when approaching the authorized load limit (◀ 2 - DESCRIPTION: INSTRUMENTS AND CONTROLS).
 - Always watch this device during handling operations.
 - If the "AGGRAVATING" hydraulic movements are cut off, perform only de-aggravating hydraulic movements in the following order (Fig. C): if necessary, raise the boom (1), retract the boom as far as possible (2) and lower the boom (3) to put down the load.

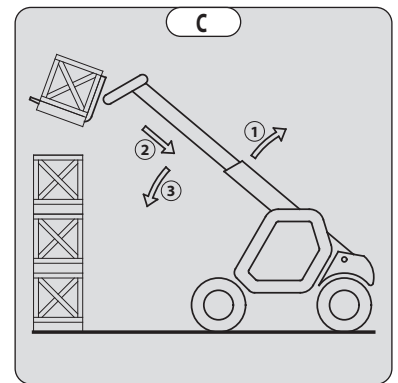

⚠ IMPORTANT ⚠

The instrument reading may be erroneous when the steering is at full lock or the rear axle is oscillated to its maximum extent.

Before lifting a load, ensure that the machine is not in any of these situations.

D - TRANSVERSE ATTITUDE OF THE MACHINE

Depending on machine model

The transverse attitude is the transverse slope of the frame with respect to the horizontal. Raising the boom reduces the machine's lateral stability. The machine's transverse attitude must be set with the boom in the down position as follows:

1 - MACHINE WITHOUT FRAME LEVELING USED ON TIRES

- Position the machine so that the bubble in the level is between the two lines (↔ 2 - DESCRIPTION: INSTRUMENTS AND CONTROLS).

2 - MACHINE WITH FRAME LEVELING USED ON TIRES

- Correct the tilt using the hydraulic control and check the horizontality with the spirit level. The bubble of the level must be between the two lines (↔ 2 - DESCRIPTION: INSTRUMENTS AND CONTROLS).

3 - MACHINE USED ON STABILIZERS

- Set the two stabilizers on the ground and raise the two front wheels of the machine (fig. D1).
- Correct the tilt using the stabilizers (Fig. D2) and check the horizontality with the spirit level. The bubble of the level must be between the two lines (↔ 2 - DESCRIPTION: INSTRUMENTS AND CONTROLS). In this position, the two front wheels must be off the ground.

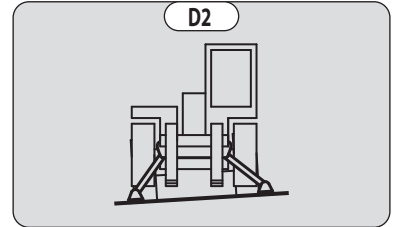
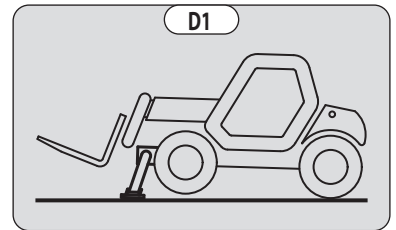

E - PICKING UP A LOAD ON THE GROUND

- Approach the machine perpendicular to the load, with the boom retracted and the forks in a horizontal position (fig. E1).
- Adjust the fork spacing and centering relative to the load to ensure stability (Fig. E2) (optional solutions exist, consult your dealer).
- Never lift a load with a single fork.

⚠ IMPORTANT ⚠

Beware of the risks of trapping or squashing limbs when manually adjusting the forks.

- Move the machine forward slowly (1) and bring the forks up to the stop in front of the load (Fig. E3). If necessary, slightly lift the boom (2) while picking up the load.
- Bring the load into the transport position.
- Tilt the load far enough backward to ensure stability (loss of load on braking or going downhill).

FOR A NON-PALLETIZED LOAD

- Tilt the carriage (1) forwards and move the machine slowly forwards (2), to insert the fork under the load (Fig. E4) (chock the load if necessary).
- Continue to move the machine (2) forward, tilting the carriage (3) (fig. E4) backward to position the load on the forks and check the load's longitudinal and lateral stability.

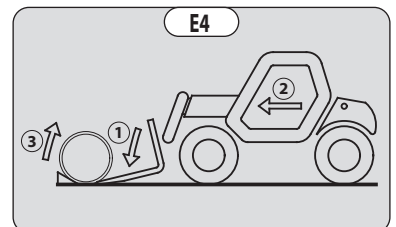
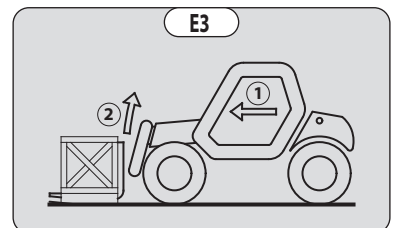
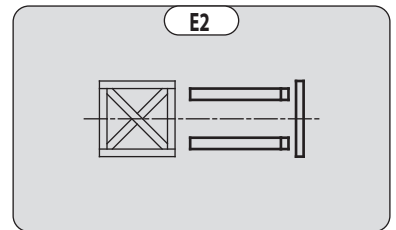
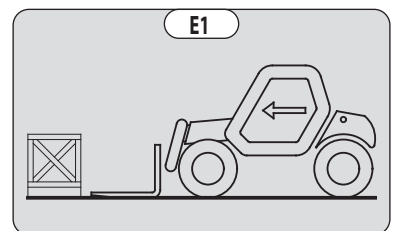

F - PICKING UP AND PUTTING DOWN A HIGH LOAD ON TIRES

⚠ IMPORTANT ⚠

You must not raise the boom if you have not checked the transverse attitude of the machine (← INSTRUCTIONS FOR HANDLING A LOAD D - TRANSVERSE ATTITUDE OF THE MACHINE).

REMINDER: Make sure that the following operations can be performed with good visibility (← OPERATING INSTRUCTIONS UNLADEN AND LADEN: D - VISIBILITY).

PICKING UP A HIGH LOAD ON TIRES

- Ensure that the forks will easily pass under the load.
- Raise and extend the boom (1) (2) until the forks are at the level of the load. If necessary, move the machine (3) forward (fig. F1), driving very slowly and carefully.
- Always remember to keep the distance necessary for inserting the forks under the load, between the stack and the machine (fig. F1) and use the shortest possible length of boom.
- Insert the forks under the load as far as they will go by alternately extending and lowering the boom (1) or, if necessary, moving the machine forward (2) (fig. F2). Activate the parking brake and place the forward/reverse selector in neutral.
- Lift the load slightly (1) and tilt the carriage (2) backwards to stabilize the load (Fig. F3).
- Tilt the load sufficiently backward to ensure its stability.
- Monitor the longitudinal stability limiter and warning device (← INSTRUCTIONS FOR HANDLING A LOAD: C - LONGITUDINAL STABILITY LIMITER AND WARNING DEVICE). If it is overloaded, set the load back down in the place from which it was picked up.
- If possible, lower the load without moving the machine. Raise the boom (1) to release the load, retract (2) and lower the jib (3) to set the load into transport position (fig. F4).
- If this is not possible, reverse the machine (1), maneuvering very gently and carefully to release the load. Retract (2) and lower the boom (3) to bring the load into the transport position (fig. F5).

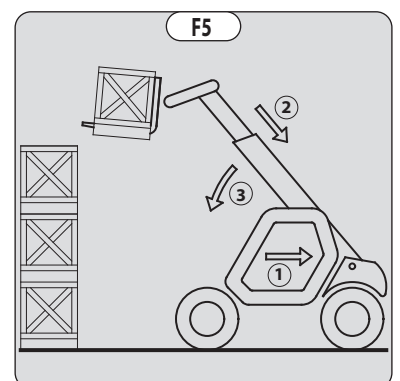
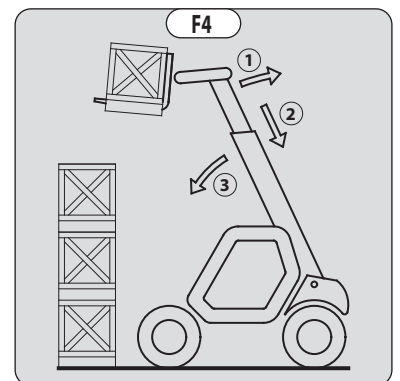
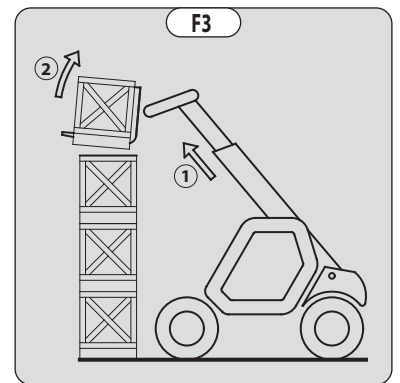
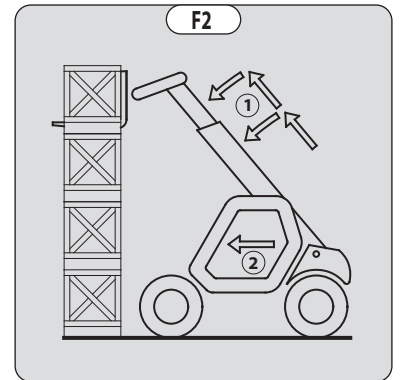
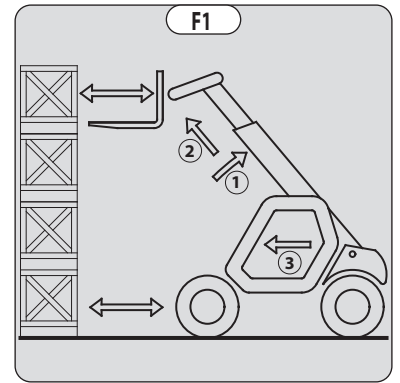

PUTTING DOWN A HIGH LOAD ON TIRES

- Approach the load in the transport position in front of the stack (Fig. F6).
- Activate the parking brake and place the forward/reverse selector in neutral.
- Raise and extend the boom (1) (2) until the load is above the stack, while monitoring the longitudinal stability limiter and warning device (☞ INSTRUCTIONS FOR HANDLING A LOAD: C - LONGITUDINAL STABILITY LIMITER AND WARNING DEVICE). If necessary, move the machine (3) forward (fig. F7), driving very slowly and carefully.
- Place the load in a horizontal position and put it down on the pile by lowering and retracting the boom (1) (2) in order to position the load correctly (Fig. F8).
- If possible, release the forks by alternately retracting and raising the boom (1) (Fig. F9). Then set the forks into transport position.
- If this is not possible, reverse the machine (1), maneuvering very slowly and carefully to release the forks (fig. F10). Then set the forks into transport position.

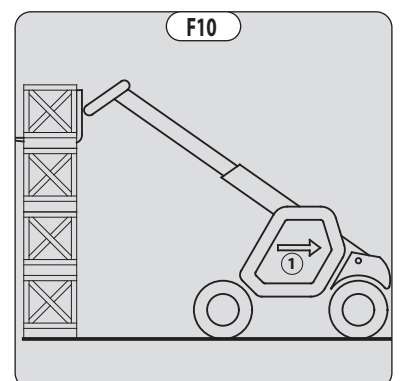
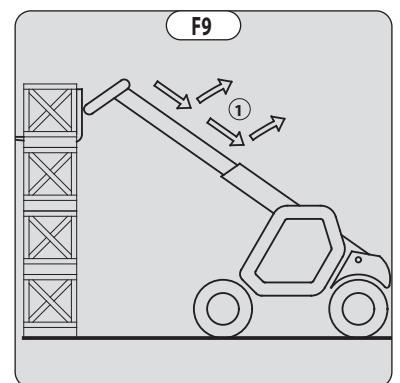
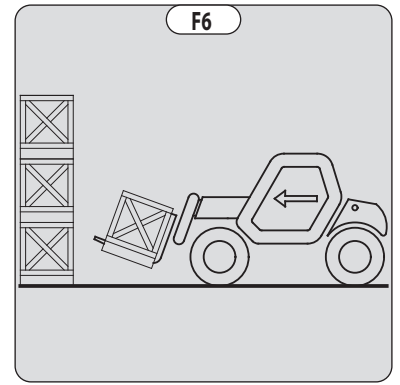

G - PICKING UP AND PUTTING DOWN A HIGH LOAD ON STABILIZERS

Depending on machine model

⚠ IMPORTANT ⚠

You must not raise the boom if you have not checked the transverse attitude of the machine (← INSTRUCTIONS FOR HANDLING A LOAD D - TRANSVERSE ATTITUDE OF THE MACHINE).

REMINDER: Make sure that the following operations can be performed with good visibility (← OPERATING INSTRUCTIONS UNLADEN AND LADEN: D - VISIBILITY).

The stabilizers are used to optimize the machine's lifting performance (← 2 - DESCRIPTION: INSTRUMENTS AND CONTROLS).

POSITIONING THE STABILIZERS WITH THE FORKS IN TRANSPORT POSITION (UNLADEN AND LADEN)

- Set the forks in transport position in front of the elevation.
- Stay far enough away to allow the boom to be raised.
- Activate the parking brake and place the forward/reverse selector in neutral.
- Set the two stabilizers on the ground and lift the two front wheels of the machine (fig. G1), while maintaining its transverse stability.

RAISING THE STABILIZERS WITH THE FORKS IN TRANSPORT POSITION (UNLADEN AND LADEN)

- Raise both stabilizers fully and at the same time.

LOWERING THE STABILIZERS WITH JIB UP (UNLADEN AND LADEN)

⚠ IMPORTANT ⚠

This operation must be exceptional and performed with great care.

- Raise the boom and retract the telescopes completely.
- Set the machine in position in front of the elevation (fig. G2), moving very slowly and carefully.
- Activate the parking brake and place the forward/reverse selector in neutral.
- Move the stabilizers very slowly and gradually as soon as they are close to the ground or in contact with it.
- Lower the two stabilizers and lift the two front wheels of the machine (fig. G3). During this operation, transverse attitude must be permanently maintained: the bubble in the level must be kept between the two lines.

SETTING THE STABILIZERS WITH THE BOOM UP (UNLADEN AND LADEN)

⚠ IMPORTANT ⚠

This operation must be exceptional and performed with great care.

- Keep the boom raised and retract the telescopes completely (Fig. G3).
- Move the stabilizers very slowly and gradually as soon as they are in contact with the ground and when they leave the ground. During this operation, transverse attitude must be permanently maintained: the bubble in the level must be kept between the two lines.
- Raise both stabilizers completely.
- Deactivate the parking brake and reverse the machine (1) very slowly and carefully to release it and lower the forks (2) into transport position (fig. G4).

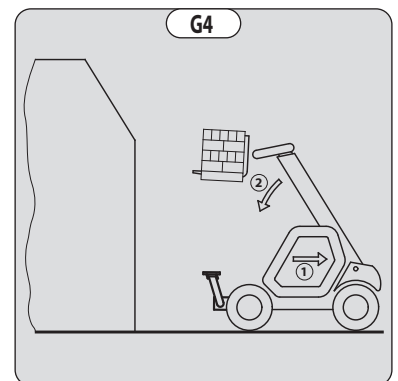
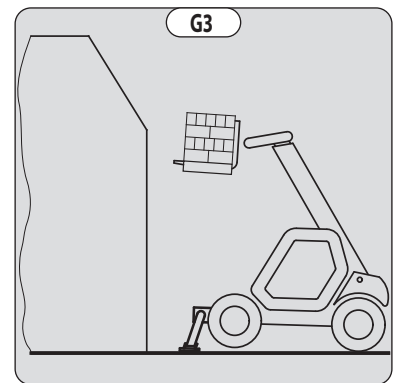
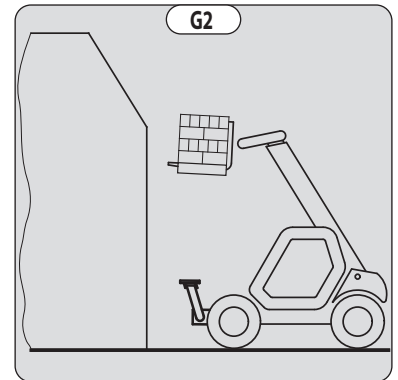
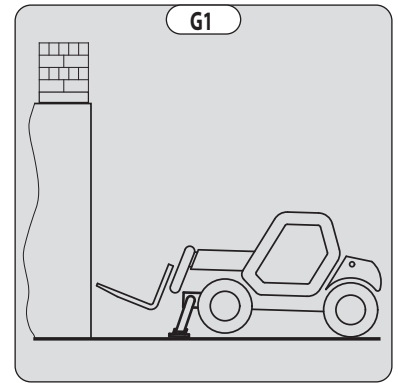

PICKING UP A HIGH LOAD ON STABILIZERS

- Ensure that the forks will easily pass under the load.
- Check the position of the machine with respect to the load and make a test run, if necessary, without picking up the load.
- Raise and extend the boom (1) (2) until the forks are at the level of the load (Fig. G5).
- Bring the forks to the stop in front of the load by alternately extending and lowering the boom (1) (Fig. G6).
- Lift the load slightly (1) and tilt the carriage (2) backwards to stabilize the load (Fig. G7).
- Monitor the longitudinal stability limiter and warning device (← INSTRUCTIONS FOR HANDLING A LOAD: C - LONGITUDINAL STABILITY LIMITER AND WARNING DEVICE). If it is overloaded, set the load back down in the place from which it was picked up.
- If possible, lower the load without moving the machine. Raise the boom (1) to release the load, retract (2) and lower the jib (3) to set the load into transport position (fig. G8).

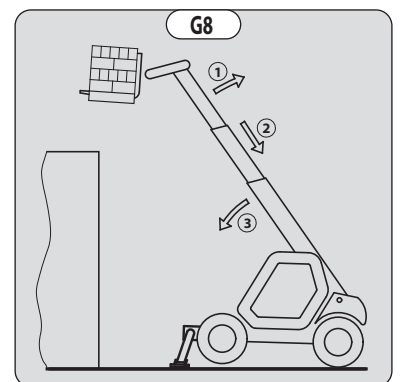
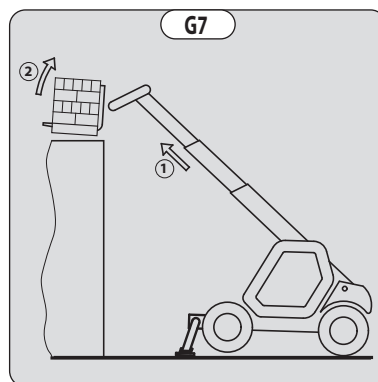
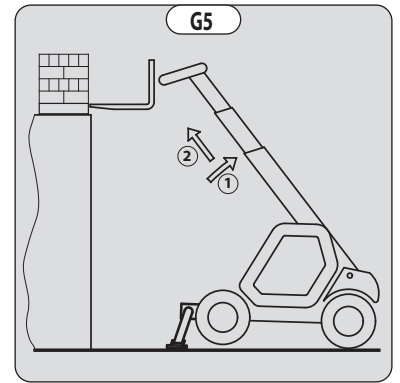

SETTING DOWN A HIGH LOAD ON STABILIZERS

- Raise and extend the boom (1) (2) until the load is above the elevation (Fig. G9), while monitoring the longitudinal stability limiter and warning device (← INSTRUCTIONS FOR HANDLING A LOAD: C - LONGITUDINAL STABILITY LIMITER AND WARNING DEVICE).
- Position the load horizontally and release it by lowering and retracting the boom (1) (2) to position the load correctly (Fig. G10).
- Free the forks by alternately retracting and raising the boom (3) (Fig. G11).
- If possible, set the boom in transport position without moving the machine.

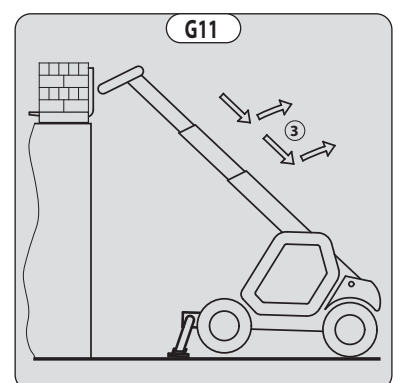
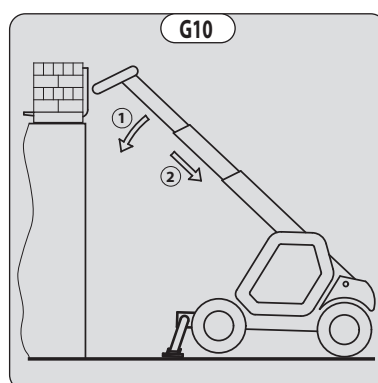
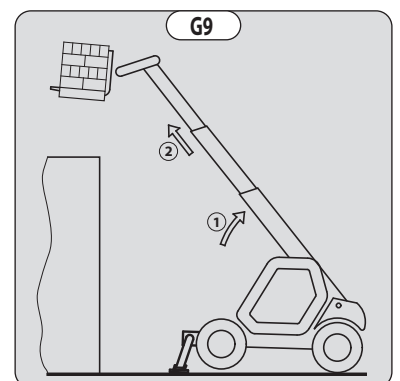

H - PICKING UP AND PUTTING DOWN A SUSPENDED LOAD

IMPORTANT

Failure to follow the above instructions may lead the machine to lose stability and overturn.

MUST be used with a machine equipped with an operational hydraulic movement cut-off device.



CONDITIONS OF USE

- The length of the sling or the chain shall be as short as possible to limit swinging of the load.
- Lift the load vertically along its axis, never by pulling sideways or lengthways.

HANDLING WITHOUT MOVING THE MACHINE

- Whether on stabilizers or on tires, the lateral attitude must not exceed 1% and the longitudinal attitude must not exceed 5%: the bubble of the level must be held at "0".
- Ensure that the wind speed is not higher than 10 m/s.
- Ensure that there is no one between the load and the machine.

I - TRAVELING WITH A SUSPENDED LOAD

- Before moving, inspect the terrain in order to avoid excessive slopes and cross-falls, bumps and potholes, or soft ground.
- Ensure that the wind speed is not higher than 36 km/h.
- The machine must not travel at more than 0.4 m/s (1.4 km/h, i.e. one quarter walking speed).
- Drive and stop the machine gently and smoothly to minimize swinging of the load.
- Carry the load a few centimeters above the ground (max. 30 cm) the shortest possible jib length. Do not exceed the offset indicated on the load chart. If the load begins to swing excessively, do not hesitate to stop and lower the jib to set down the load.
- Before moving the machine, check the longitudinal stability limiter and warning device ( 2 - DESCRIPTION: INSTRUMENTS AND CONTROLS), only the green LEDs and possible the yellow LEDs should be lit
- During transport, the lift truck operator must be assisted by a person on the ground (standing a minimum of 3 m from the load), who will limit swinging of the load using a bar or a rope. Ensure that this person is always clearly in view.
- The lateral attitude must not exceed 5%: the bubble in the level must be kept between the two "MAX" marks.
- The longitudinal attitude must not exceed 15% with the load facing uphill and 10% with the load facing downhill.
- The boom angle must not exceed 45°.
- If the first red LED of the longitudinal stability limiter and warning device ( 2 - DESCRIPTION: INSTRUMENTS AND CONTROLS) comes on while traveling, gently bring the machine to a halt and stabilize the load. Retract the telescope to reduce the offset of the load.

INSTRUCTIONS FOR USE AS A LOADER

For agricultural-type machines (MLT range)

A - LOADING

⚠ IMPORTANT ⚠

You must not raise the boom if you have not checked the transverse attitude of the machine (← INSTRUCTIONS FOR HANDLING A LOAD D - TRANSVERSE ATTITUDE OF THE MACHINE).

REMINDER: Make sure that the following operations can be performed with good visibility (← OPERATING INSTRUCTIONS UNLADEN AND LADEN: D - VISIBILITY).

FILLING THE BUCKET

- Place the bottom of the bucket in a horizontal position, just in contact with the ground (1) (Fig. A1).
- Move forward gradually (2) while simultaneously raising the boom and tilting the bucket backwards (3), for improved filling and breakout (Fig. A1).
- Reverse the machine (1) very carefully and gently to free the bucket. Lower the boom (2) into the transport position (Fig. A2).

⚠ IMPORTANT ⚠

Tilt the bucket sufficiently back to avoid spilling product and ensure its stability (loss of product under braking).

LOADING A TRAILER

- Approach the side of the trailer in the transport position (Fig. A3).
- Raise and extend the boom (1) (2) until the bucket is above the trailer, while monitoring the longitudinal stability limiter and warning device (← INSTRUCTIONS FOR HANDLING A LOAD: C - LONGITUDINAL STABILITY LIMITER AND WARNING DEVICE) (Fig. A4).
- Drive the machine forward (3) very carefully and gently so that the bucket empties its load in the center of the trailer (Fig. A4).
- Immobilize the machine with the brake pedal and put the reversing shift lever in neutral.

N.B.: Immobilizing the machine with the brake pedal means that the transmission should be in neutral. Failure to follow this recommendation may lead to overheating and damage to the brakes.

- Slowly discharge the product (4) (Fig. A4).
- Tilt the bucket backwards (1) and reverse the machine (2) very carefully and gently (Fig. A5).
- Retract (3) and lower the boom (4) into the transport position (Fig. A5).

B - BACKFILLING

- Place the bottom of the bucket in a horizontal position, just in contact with the ground (1) (Fig. B1).
- Drive forward gradually (2). Once filled, the bucket will act as a leveling blade (Fig. B1).

⚠ IMPORTANT ⚠

When driving, beware of trenches as well as recently excavated and/or backfilled ground.

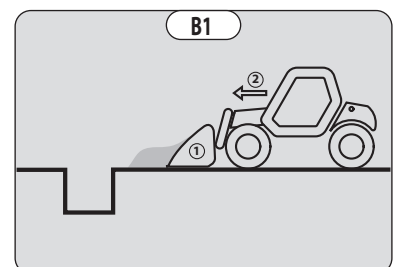
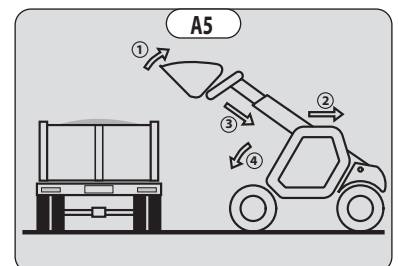
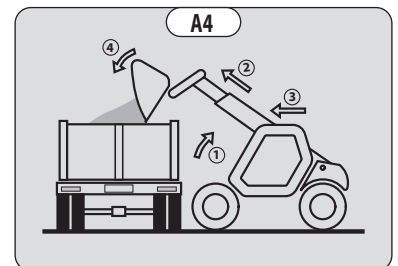
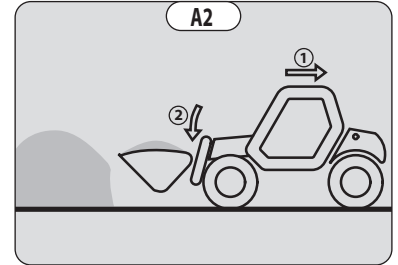
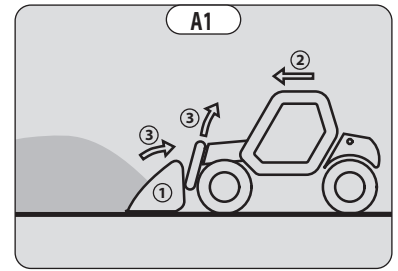

INSTRUCTIONS FOR USING THE MOBILE ELEVATING WORK PLATFORM

For machines equipped with a MOBILE ELEVATING WORK PLATFORM

A - AUTHORIZATION FOR USE

- Operation of the platform requires further authorization in addition to that of the machine.

B - SUITABILITY OF THE PLATFORM FOR THE JOB

- Our machines fitted with mobile elevating work platforms are compliant with standard **EN 280** for Europe and standard **AS/NZS 1418.10:2011** for Australia, corresponding to the classification of Group C1 to C3 in accordance with this standard.
- MANITOU has ensured that this platform is suitable for use under the normal operating conditions provided in this operator's manual, with a STATIC test coefficient of 1.25 and a DYNAMIC test coefficient of 1.1 as specified in harmonized European standard **EN 280** for mobile elevating work platforms.
- Before commissioning, the company manager must make sure that the platform is appropriate for the work to be done, and perform certain tests (in accordance with current legislation).

C - PROVIDED ON THE PLATFORM

- Wear suitable clothing when using the platform, avoid loose-fitting garments.
- Never use the platform with hands or shoes that are wet or soiled with greasy substances.
- Remain alert at all times when using the platform. Do not listen to the radio or music using headphones or earphones.
- MANITOU strongly recommends wearing a safety harness attached to an attachment point in the platform. Wearing a safety harness or other personal protection equipment against falls may be compulsory. Comply with local, government and national regulations in force, employer's safety rules and work site regulations .
- The safety harness or other personal protection equipment against falls must comply with local, government, and national regulations in force. They must be inspected in accordance with the regulations in force.
- The control units must never be used for any other than their intended purposes (e.g. Climbing onto or down from the machine, coat hanger, etc.).
- Safety helmets must be worn.
- The operator must always be in his normal position in the driver's cab: it is prohibited to have arms or legs, or generally any part of the body, outside the platform.
- Ensure that materials loaded onto the platform (pipes, cables, containers, etc.) cannot fall out. Do not pile these materials to the point where it is necessary to step over them.

D - USING THE PLATFORM

- However experienced they may be, operators must acquaint themselves with the emplacement and operation of all control instruments prior to operating the platform.
- Check before use that the platform has been correctly assembled and locked onto the machine.
- Do not enter or exit the platform unless it is fully lowered.
- Always enter and exit the platform through the gate or using the sliding mid rails (depending on the model).
- Always enter and exit facing the interior of the platform.
- Always use both hands and one foot or both feet and one hand to enter and exit the platform.
- Make sure that the sliding intermediate cross members (depending on the model) are in the lower position and that the gate is properly closed (depending on the model) before using this platform.
- Do not attach the sliding mid rails in the high position.
- The platform should be operated in an area free of any obstructions or danger when it is lowered to the ground.
- The operator using the platform must be aided by someone on the ground with adequate training.
- You should stay within the limits set out in the platform load chart.
- The lateral constraints are limited (↩ 2 - DESCRIPTION: SPECIFICATIONS).
- It is strictly forbidden to suspend a load from the platform or the machine's boom without an attachment provided for the purpose (↩ INSTRUCTIONS FOR HANDLING A LOAD: H - PICKING UP AND PUTTING DOWN A SUSPENDED LOAD).
- The platform cannot be used as a crane or a lift for permanently transporting people or materials, nor as jacks or supports.
- The machine must not be moved with one (or more) person(s) on the platform.
- It is forbidden to transport people on the platform using the hydraulic controls in the machine's cab (except in case of rescue).
- The operator must not climb onto to off the platform when it is not on ground level (jib retracted and in the down position).
- The machine must not be fitted with unauthorized attachments that increase the windage of the assembly.
- Do not use ladders or improvised structures on the platform to gain extra height.
- Do not climb onto the rails of the platform to gain extra height.
- It is forbidden to use the platform on forks. The fork slots are only to, be used for storing the platform and not for lifting people under any circumstances.

E - ENVIRONMENT

- Respect a safety distance between power lines or live components and any part of the body, any conductive object or any part of the machine, unless the local, government and national applicable regulations, the safety rules of the employer or construction site regulations are more strict in terms of distance required.
- Allow for platform movement and swaying or sagging power lines.

⚠ IMPORTANT ⚠

It is forbidden to use the platform close to electricity cables. Maintain the specified safe distances.

RATED VOLTAGE (VOLTS)	SAFETY DISTANCE (METERS)
50 < U < 1000	2,30 M
1000 < U < 30000	2,50 M
30000 < U < 45000	2,60 M
45000 < U < 63000	2,80 M
63000 < U < 90000	3,00 M
90000 < U < 150000	3,40 M
150000 < U < 225000	4,00 M
225000 < U < 400000	5,30 M
400000 < U < 750000	7,90 M

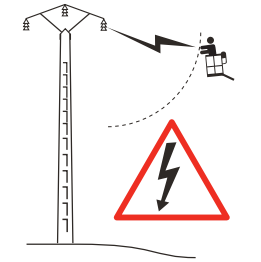

⚠ IMPORTANT ⚠

It is strictly forbidden to use the platform when the wind speed exceeds 45 km/h.

- To visually recognize this wind speed, refer to the empirical wind evaluation scale below:

BEAUFORT scale (wind speed at a height of 10 m on a flat site)						
Force	Type of wind	Speed (knots)	Speed (km/h)	Speed (m/s)	Effects on Land	Sea conditions
0	Calm	0 - 1	0 - 1	< 0.3	Smoke rises vertically.	Sea is like a mirror.
1	Light air	1 - 3	1 - 5	0.3 - 1.5	Smoke indicates direction of wind.	Ripples with appearance of scale, no foam crests.
2	Light breeze	4 - 6	6 - 11	1.6 - 3.3	Wind felt on face, leaves rustle.	Short wavelets, but pronounced.
3	Gentle breeze	7 - 10	12 - 19	3.4 - 5.4	Leaves and small twigs in constant motion.	Very small waves, crests begin to break.
4	Moderate breeze	11 - 16	20 - 28	5.5 - 7.9	Wind raises dust and loose pieces of paper; small branches are moved.	Small waves, becoming longer, numerous whitecaps.
5	Fresh breeze	17 - 21	29 - 38	8 - 10.7	Small trees in leaf begin to sway.	Wavelets form on inland waters; moderate waves, taking longer form.
6	Strong breeze	22 - 27	39 - 49	10.8 - 13.8	Large branches in motion, whistling heard in overhead wires, umbrella use becomes difficult.	Larger waves forming, whitecaps everywhere, some spray.
7	Near gale	28 - 33	50 - 61	13.9 - 17.1	Whole trees in motion, inconvenience felt when walking against the wind.	Sea heaps up; white foam from breaking waves begins to be blown in streaks along the direction of the wind.
8	Gale	34 - 40	62 - 74	17.2 - 20.7	Wind breaks twigs off trees; impedes progress.	Moderately high waves of greater length; edges of crests begin to break into spindrift.
9	Strong gale	41 - 47	75 - 88	20.8 - 24.4	Wind damages roofs (chimneys, slates, etc.).	High waves, crests of waves begin to topple, streaks of foam; reduced visibility.
10	Storm	48 - 55	89 - 102	24.5 - 28.4	Seldom experienced inland; trees uprooted; considerable structural damage occurs.	Very high waves; white streaks of foam; reduced visibility.
11	Violent storm	56 - 63	103 - 117	28.5 - 32.6	Very rare, widespread damage.	Exceptionally high waves able to hide medium sized ships from view, reduced visibility.
12	Hurricane	64 +	118 +	32.7 +	Devastating damage.	Sea completely white; air filled with foam and spray, very reduced visibility.

F - MAINTENANCE

⚠ IMPORTANT ⚠

Your platform must be periodically inspected to ensure its continued compliance.

The frequency of this inspection is defined by the legislation in force in the country in which the platform is used.

In France, a general periodic inspection every 6 months (Decree of March 1, 2004).

INSTRUCTIONS FOR USING THE RADIO-CONTROL

For machines with RC radio control

HOW TO USE THE RADIO-CONTROL

SAFETY INSTRUCTIONS

⚠ IMPORTANT ⚠

It is prohibited to lift people in the platform using the radio-control.

It is prohibited to use the radio-control from the platform:

- This radio-control consists of electronic and mechanical safety elements. It cannot receive commands from another transmitter because the internal encoding is unique to each radio-control.

⚠ IMPORTANT ⚠

If it is used improperly or incorrectly, there is a risk of danger to:

- *The physical and mental health of the user or others.*
- *The machine and other neighboring items.*

Everyone working with this radio-control:

- *Must be qualified in line with current regulations and trained accordingly.*
- *Must follow this instruction manual as closely as possible.*

- The system is used to control the machine remotely via radio waves. Commands are also transmitted if the machine is out of sight (behind an obstacle or a building for example), this is why:
 - After stopping the truck and removing the key switch (only possible when it is stationary), always place the transmitter in a safe, dry place.
 - Before performing any installation, servicing or repair work, always switch off power sources (in particular, electric welding devices and electric head units on hydraulic distributors must be disconnected at each section).
 - Never remove or alter the safety devices (such as the hand-guard frame, key, emergency stop button, etc.).

⚠ IMPORTANT ⚠

Never drive the machine if it is not continuously and perfectly within view of the operator.

- Before leaving the transmitter, the operator must make sure that it cannot be used by an unauthorized third person: either by removing the key button from the transmitter or locking it in an inaccessible place.
- The user must ensure that the instruction manual is accessible at all times and that operators have read and understood it.

INSTRUCTIONS

- Take up position in a stable place with no risk of slipping.
- Before using the transmitter, make sure there is nobody within the working area.
- Only use the transmitter with its carrying device or installed correctly on the platform.

⚠ IMPORTANT ⚠

When you remove the transmitter, remove the accumulator and key button so that it cannot be used accidentally or deliberately by anyone else.

PROTECTIVE DEVICES

- The machine will be immobilized within a maximum of 450 milliseconds (approx. 0.5 second):
 - If the emergency stop button of the transmitter is pressed (50 milliseconds), or that of the machine.
 - If the transmission distance of the radio waves is exceeded.
 - If the transmitter is faulty.
 - If an interfering radio signal is received from elsewhere.
 - If the accumulator is removed from its housing in the transmitter.
 - If the battery reaches the end of its autonomy.
 - If the transmitter is switched off by turning the key switch to the off position.
- These protective devices are provided for the safety of personnel and property and must never be modified, removed or bypassed in any way whatsoever!
- The hand-guard frame prevents external action on a joystick (e.g. if the transmitter is dropped, or if the operator leans on a guard-rail).
- An electronic safety device prevents radio transmission from being initiated if the joysticks are not mechanically and electrically at rest and if the internal combustion engine speed selector is not set to idle.

⚠ IMPORTANT ⚠

In an emergency, press the transmitter emergency stop button immediately; then follow the manual's instructions (➔ 2 - DESCRIPTION: INSTRUMENTS AND CONTROLS).

MACHINE MAINTENANCE INSTRUCTIONS

GENERAL INSTRUCTIONS

⚠ IMPORTANT ⚠

Carefully read and understand this operator's manual before any operation on this machine.

Carry out all repairs immediately, even if the repairs concerned are minor.

Repair all leaks immediately, even if the leak concerned is minor.

Be careful of the risk of burns and splashing (exhaust, radiator, engine, hydraulic oil, etc.).

- Make sure the area is adequately ventilated before starting up the machine.
- Wear clothes suitable for the maintenance of the machine. Avoid wearing jewelry and loose clothes. Tie back and protect your hair, if necessary.
- Stop the engine and remove the ignition key before carrying out any work.

PLACING THE JIB SAFETY WEDGE

- The machine is equipped with a boom safety wedge (↔ 2 - DESCRIPTION: INSTRUMENTS AND CONTROLS) that must be installed on the lifting cylinder rod when working beneath the boom.
- Boom retracted without forks or attachments.

ACCORDING TO INSTALLATION

FITTING THE WEDGE

- Fully raise the jib.
- Place the safety wedge 1 on the rod of the lifting cylinder and secure with the rod 2 and the pin 3.
- Slowly lower the jib then stop the hydraulic movements before it comes into contact with the wedge.

REMOVING THE WEDGE

- Fully raise the jib.
- Remove the pin and the rod.
- Return the safety wedge to the storage location provided on the machine.

⚠ IMPORTANT ⚠

Only use the wedge supplied with the machine.

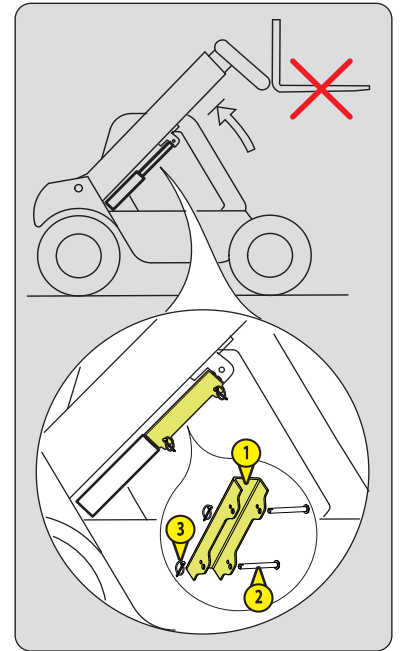

ACCORDING TO INSTALLATION

FITTING THE WEDGE

- Fully raise the jib.
- Loosen the thumbwheels 1.
- Assemble the parts of the safety wedge 2 around the cylinder rod and lock with the pins 3.

NOTE: the stop flats 4 of the safety wedge must be located towards the bottom of the lifting cylinder 5.

- Slowly lower the jib then stop the hydraulic movements before it comes into contact with the wedge.

REMOVING THE WEDGE

- Fully raise the jib.
- Remove the pins 3.
- Put the parts of the safety wedge 2 back on the machine and lock them with the thumbwheels 1.
- Replace the pins 3 on the parts of the safety wedge.

⚠ IMPORTANT ⚠

Only use the wedge supplied with the machine.

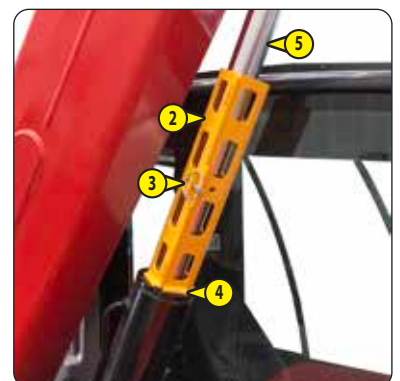
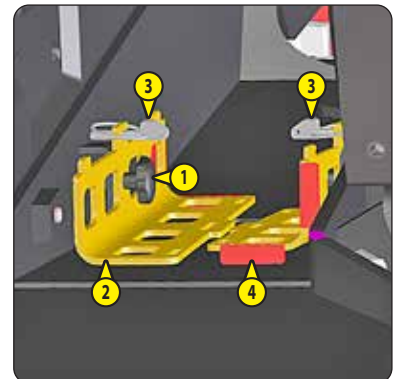

MAINTENANCE

- Perform the periodic service (↩ 3 - MAINTENANCE) to keep your machine in good working order. Failure to perform periodic maintenance may invalidate the contractual warranty.

MAINTENANCE LOGBOOK

- The maintenance operations carried out in accordance with the recommendations given in section 3 - MAINTENANCE and the other inspection, servicing or repair operations or modifications performed on the machine shall be recorded in a maintenance logbook.
- The entry for each operation should include the date of the work, the names of the individuals or companies having performed them, the type of operation and its frequency, if applicable.
- If machine elements are replaced, the part numbers of these elements shall be indicated.

LUBRICANT AND FUEL LEVELS

- Use the recommended lubricants (never use contaminated lubricants).
- Do not fill the fuel tank when the engine is running.
- Only fill up the fuel tank in areas specified for this purpose.
- Do not fill the fuel tank to the maximum level.
- Do not smoke or approach the machine with a flame when the fuel tank is open or is being filled.

HYDRAULICS

- Any work on the load handling hydraulic circuit is forbidden except for the operations described in chapter: 3 - MAINTENANCE.
- Do not attempt to loosen unions, hoses or any hydraulic component with the circuit under pressure.



COUNTERBALANCE VALVE: *it is dangerous to change the setting or remove the counterbalance valves or safety valves which may be fitted to the cylinders of your machine.*

HYDRAULIC ACCUMULATOR: *dismantling hydraulic accumulators and their pipes which may be fitted on your machine is dangerous. Such operations must only be performed by approved personnel (consult your dealer).*

ELECTRICITY

- Do not short-circuit the starter relay to start the engine. If the forward/reverse selector is not in neutral and the parking brake is not on, the machine may suddenly start to move.
- Do not place metal items on the battery.
- Disconnect the battery before working on the electrical circuit.

WELDING ON THE MACHINE



Welding operations on the machine for the purposes of maintenance or repairs must only be carried out by people authorized by MANITOU.

- Disconnect the battery before any welding operations on the machine.
- When carrying out electric welding work on the machine, connect the negative cable from the equipment directly to the part being welded so as to avoid very high current passing through the alternator.
- Never carry out welding or work which gives off heat on an assembled tire. The heat would increase the pressure which could cause the tire to explode.
- If the machine is equipped with an electronic control unit, disconnect it before starting to weld so as to avoid the risk of causing irreparable damage to electronic components.

WASHING THE MACHINE

⚠ IMPORTANT ⚠

When washing with a high pressure cleaner, avoid the engine air intakes, the cylinder rod wiper seals, the hinges, the structural components and the electrical connections, etc.

- Clean the machine or at least the area concerned before any intervention.
- Remember to close and lock all openings on the machine (doors, windows, cowls, etc.).
- If necessary, protect against penetration of water, steam or cleaning agents, components susceptible of being damaged, particularly electrical components and connections and the injection pump.
- Clean the machine of any traces of fuel, oil or grease.

TRANSPORTING THE MACHINE

⚠ IMPORTANT ⚠

Transporting the machine involves real risks for the operator and others involved.

- Towing, winching, slinging or transporting the machine (⚠ 3 - MAINTENANCE).

PROLONGED MACHINE SHUTDOWN

INTRODUCTION

⚠ IMPORTANT ⚠

Procedures to follow for long duration standstill and for bringing back the machine into service must be performed by your dealership.

This period of long duration standstill must not exceed 12 months.

After 12 months, repeat the procedures for putting the machine back into service and long-term shutdown.

The recommendations below are intended to prevent the machine from being damaged when it is not used for a period of more than 3 months.

PREPARATION OF THE MACHINE

- Clean the machine thoroughly.
- Check and repair any fuel, oil, water or air leaks.
- Replace or repair any worn or damaged parts.
- Wash the painted surfaces of the machine in clear and cold water and wipe them.
- Touch up the paintwork if necessary.
- Lower the lifting structure fully.
- Retract the telescopic arms.
- Release the pressure in the hydraulic circuits.
- Shut down the machine.

DEF (Diesel Exhaust Fluid) TANK

Depending on machine model

- Drain down and rinse the DEF (Diesel Exhaust Fluid) tank.
- Replace the "DEF" (Diesel Exhaust Fluid) feed pump filter (⚠ 3 - MAINTENANCE).
- Slowly fill the tank with new DEF up to the bottom of the filler neck.
- Start up the machine to pressurize the circuit and bring it up to working temperature, then shut down the engine.
- If necessary, top up the tank.

PROTECTING THE ENGINE

- Contact your dealer to obtain the procedure for protecting the inside of the engine (use of protection product).
- Fill the tank with fuel (3 - MAINTENANCE).
- Replace the engine oil and oil filter (3 - MAINTENANCE).
- Replace the coolant (3 - MAINTENANCE).
- Leave the engine running at idling speed for a few minutes, then switch off.
- Run the engine for a short time so that the oil and cooling liquid circulate inside.
- Disconnect the battery and store it in a safe place away from the cold, after charging it to maximum capacity.
- Block the outlet with waterproof adhesive tape.
- Remove the drive belts and store them in a safe place.
- Disconnect the engine cut-off solenoid on the injection pump and carefully insulate the connection.

MACHINE PROTECTION

Place the machine on level ground.

- Set the machine on axle stands so that the tires are off the ground.
- Deactivate the parking brake (*depending on machine model*).
- Protect cylinder rods which will not be retracted from corrosion.
- Wrap the wheels.

N.B.: If the machine is to be stored outdoors, cover it with a waterproof tarpaulin.

RETURNING THE MACHINE TO SERVICE



Make sure the area is adequately ventilated before starting up the machine.

- Remove the waterproof adhesive tape from all the orifices.
- Remove the protection from the cylinder rods and wheels.
- Refit and reconnect the battery.
- Activate the parking brake and remove the axle stands.
- Perform the daily maintenance operations (3 - MAINTENANCE).
- Perform the weekly maintenance operations (3 - MAINTENANCE).
- Drain and clean the fuel tank (3 - MAINTENANCE).
- Fill the fuel tank with clean diesel filtered through the filler port.
- Replace the fuel filter (3 - MAINTENANCE).
- Replace the fuel pre-filter (3 - MAINTENANCE) (*depending on the model of machine*).
- Drain and rinse the DEF tank (*depending on the machine model*).
- Top up, slowly fill the tank with new "DEF" (Diesel Exhaust Fluid) up to the bottom of the filler neck (*depending on the machine model*).
- Refit and set the tension in the belts. (3 - MAINTENANCE).
- Turn the engine over with the starter, to allow the oil pressure to rise.
- Reconnect the engine cut-off solenoid.
- Lubricate the machine completely (3 - MAINTENANCE).
- Start up the machine, following the operating and safety instructions (OPERATING INSTRUCTIONS UNLADEN AND LADEN).
- Perform all the lifting structure's hydraulic movements up to the end position for each cylinder.

DISPOSING OF THE MACHINE

⚠ IMPORTANT ⚠

Consult your dealer before disposing of the machine.

RECYCLING OF MATERIALS

METALS

- Metals are 100% recoverable and recyclable.

PLASTICS

- Plastic parts are identified with a marking in accordance with current regulations.
- A limited range of materials is used to simplify the recycling process.
- The majority of the plastic components are made of "thermoplastic" plastics, which are easily recycled by melting, granulating or grinding.

RUBBER

- Tires and seals can be ground for use in cement manufacture or to obtain reusable granules.

GLASS

- Glass items can be removed and collected for processing by glaziers.

ENVIRONMENTAL PROTECTION

By entrusting the maintenance of your machine to the MANITOU network, the risk of pollution is limited and the contribution to environmental protection is made.

WORN OR DAMAGED PARTS

- Do not dump them in the countryside.
- MANITOU and its network have signed-up to a scheme of environmental protection through recycling.

USED OIL

- The MANITOU network organizes the collection and processing of used oil.
- By handing over your waste oil to MANITOU, the risk of pollution is limited.

USED BATTERIES

- Do not throw away batteries, as they contain metals that are harmful for the environment.
- Return them to the MANITOU network or any other approved collection point.

N.B.: MANITOU aims to manufacture machines that provide the best performance and limit polluting emissions.

2 - DESCRIPTION

2 - DESCRIPTION

<u>EC DECLARATION OF CONFORMITY</u>	2-4
<u>CE DECLARATION OF CONFORMITY (TRACTOR TYPE APPROVAL)</u>	2-6
<u>UKCA DECLARATION OF CONFORMITY</u>	2-8
<u>UKCA DECLARATION OF CONFORMITY (TRACTOR TYPE APPROVAL)</u>	2-9
<u>PARTICULATE FILTER / SPARK ARRESTOR CERTIFICATE OF CONFORMITY</u>	2-10
<u>SAFETY PLATES AND STICKERS</u>	2-12
<u>IDENTIFICATION OF THE LIFT TRUCK</u>	2-16
<u>SPECIFICATIONS</u>	2-20
<u>TIRES</u>	2-24
<u>DIMENSIONS</u>	2-26
<u>LOAD CHARTS</u>	2-28
<u>VISIBILITY</u>	2-30
<u>INSTRUMENTS AND CONTROLS</u>	2-32
<u>EMERGENCY BRAKE</u>	2-34
<u>EMERGENCY EXIT</u>	2-35
<u>TOWING DEVICE</u>	2-66
<u>DESCRIPTION AND USE OF THE OPTIONS</u>	2-72

EC DECLARATION OF CONFORMITY

This document is a specimen of the CE Declaration of Conformity and includes the contents of the original declaration supplied with the machine.

This specimen and the original document may contain fields that are not applicable to your machine. These fields are left blank if not applicable.

Refer to the original Declaration of Conformity for all data applicable to your machine.

1) **DÉCLARATION «CE» DE CONFORMITÉ (originale)** **«EC» DECLARATION OF CONFORMITY (original)**

2) Constructeur, *Manufacturer* : **MANITOU BF**

3) Adresse, *Address* : **430, RUE DE L'AUBINIÈRE - B.P 10249
44158 - ANCENIS - CEDEX - FRANCE**

4) Titulaire du dossier technique, *Holder of the technical file* : **MANITOU BF**

3) Adresse, *Address* : **430, RUE DE L'AUBINIÈRE - B.P 10249
44158 - ANCENIS - CEDEX - FRANCE**

5) Le constructeur déclare que la machine décrite ci-après, *The manufacturer declares that the machine described below* :

Rough-terrain variable-reach truck

MLT630 115D ST5 S1

6) Est conforme aux directives suivantes et à leurs transpositions en droit national (si applicables),
Complies with the following directives and their transpositions into national law (if applicable) :

2006/42/CE

7) Pour les machines annexe IV, *For annex IV machines* : Non applicable

8) Numéro d'attestation, *Certificate number* : Non applicable

9) Organisme notifié, *Notified body* : Non applicable

2000/14/CE + 2005/88/CE

10) Procédure appliquée, *Applied procedure* : ANNEXE VIII

9) Organisme notifié, *Notified body* : **SNCH
11 ROUTE DU LUXEMBOURG
5201 SANDWEILER - LUXEMBOURG**

11) Niveau de puissance acoustique, *Sound power level* :

12) Mesuré, *Measured* : dB (A)

13) Garanti, *Guaranteed* : dB (A)

2014/30/UE

14) Normes harmonisées utilisées, *Harmonised standards used* :

EN1459 ; EN 12895

15) Normes ou dispositions techniques utilisées, *Standards or technical provisions used* :

16) Fait à, *Done at* :

17) Date, *Date* :

18) Nom du signataire, *Name of signatory* :

19) Fonction, *Function* :

20) Société, *Company* :

21) Signature, *Signature* :

bg : 1) удостоверение за « CE » съответствие (оригинална), 2) Фирмата, 3) Адрес, 4) Техническо досие, 5) Фабрикант на описаната по-долу машина, 6) Обявява, че тази машина, 7) товара на следните директиви и на тяхното съответствие национално право, 8) За машините към допълнение IV, 9) Номер на удостоверението, 10) Наименувана фирма, 15) хармонизирани стандарти използвани, 16) стандарти или технически правила, използвани, 17) Изработено в, 18) Дата, 19) Име на разписалия се, 20) Функция, 21) Функция.

cs : 1) ES prohlášení o shodě (původní), 2) Název společnosti, 3) Adresa, 4) Technická dokumentace, 5) Výrobce níže uvedeného stroje, 6) Prohlašuje, že tento stroj, 7) Je v souladu s následujícími směrnicemi a směrnicemi transponovanými do vnitrostátního práva, 8) Pro stroje v příloze IV, 9) Číslo certifikátu, 10) Notifikační orgán, 15) harmonizované normy použity, 16) Normy a technických pravidel používaných, 17) Místo vydání, 18) Datum vydání, 19) Jméno podepsaného, 20) Funkce, 21) Podpis.

da : 1) EF Overensstemmelseserklæring (original), 2) Firmaet, 3) Adresse, 4) tekniske dossier, 5) Konstruktor af nedenfor beskrevne maskine, 6) Erklærer, at denne maskine, 7) Overholder nedennævnte direktiver og disses gennemførelse til national ret, 8) For maskiner under bilag IV, 9) Certifikat nummer, 10) Bemyndigede organ, 15) harmoniserede standarder, der anvendes, 16) standarder eller tekniske regler, 17) Udfærdiget i, 18) Dato, 19) Underskrivers navn, 20) Funktion, 21) Underskrift.

de : 1) EG-Konformitätserklärung (original), 2) Die Firma, 3) Adresse, 4) Technischen Unterlagen, 5) Hersteller der nachfolgend beschriebenen Maschine, 6) Erklärt, dass diese Maschine, 7) den folgenden Richtlinien und deren Umsetzung in die nationale Gesetzgebung entspricht, 8) Für die Maschinen laut Anhang IV, 9) Bescheinigungsnummer, 10) Benannte Stelle, 15) angewandten harmonisierten Normen, 16) angewandten sonstigen technischen Normen und Spezifikationen, 17) Ausgestellt in, 18) Datum, 19) Name des Unterzeichners, 20) Funktion, 21) Unterschrift.

el : 1) Δήλωση συμμόρφωσης CE (πρωτότυπο), 2) Η εταιρεία, 3) Διεύθυνση, 4) τεχνικό φάκελο, 5) Κατασκευάστρια του εξής περιγραφόμενου μηχανήματος, 6) Δηλώνει ότι αυτό το μηχάνημα, 7) Είναι σύμφωνο με τις εξής οδηγίες και τις προσαρμογές τους στο εθνικό δίκαιο, 8) Για τα μηχανήματα παραρτήματος IV, 9) Αριθμός δήλωσης, 10) Κοινοποιημένος φορέας, 15) εναρμονισμένα πρότυπα που χρησιμοποιούνται, 16) Πρότυπα ή τεχνικούς κανόνες που χρησιμοποιούνται, 16) Είναι σύμφωνο με τα εξής πρότυπα και τεχνικές διατάξεις, 17) Έν, 18) Ημερομηνία, 19) Όνομα του υπογράφοντος, 20) Θέση, 21) Υπογραφή.

es : Declaración DE de conformidad (original), 2) La sociedad, 3) Dirección, 4) expediente técnico, 5) Constructor de la máquina descrita a continuación, 6) Declara que esta máquina, 7) Está conforme a las siguientes directivas y a sus transposiciones en derecho nacional, 8) Para las máquinas anexo IV, 9) Número de certificación, 10) Organismo notificado, 15) normas armonizadas utilizadas, 16) Otras normas o especificaciones técnicas utilizadas, 17) Hecho en, 18) Fecha, 19) Nombre del signatario, 20) Función, 21) Firma.

et : 1) EÜ vastavusdeklaratsioon (algupärane), 2) Äriühing, 3) Aadress, 4) Tehniline dokumentatsioon, 5) Seadme tootja, 6) Kinnitab, et see toode, 7) On vastavuses järgmiste direktiivide ja nende riigisisesesse õigusesse ülevõtmiseks vastuvõetud õigusaktidega, 8) IV lisas loetletud seadmete puhul, 9) Tunnistuse number, 10) Tunnistuse number, 15) kasutatud ühtlustatud standardite, 16) Muud standardites või spetsifikatsioonides kasutatakse, 17) Väljaandmise koht, 18) Väljaandmise aeg, 19) Alkiriastaja nimi, 20) Amet, 21) Alkiri.

fi : 1) EY-vaatimustenmukaisuusvakuutus (alkuperäiset), 2) Yritys, 3) Osoite, 4) teknisen eritelmän, 5) Jäljessä kuvattu koneen valmistaja, 6) Vakuuttaa, että tämä kone, 7) Täyttää seuraavien direktiivien sekä niitä täytäntöönpanon kansallisten säännösten vaatimukset, 8) Liitteen IV koneiden osalta, 9) Todistuksen numero, 10) Ilmoitettu laitos, 15) yhdenmukaistettuja standardeja käytetään, 16) muita standardeja tai eritelmiä, 17) Paikka, 18) Aika, 19) Allekirjoittajan nimi, 20) Toimi, 21) Allekirjoitus.

ga : 1) « CE » dearbhú comhréireachta (bunaidh), 2) An comhlacht, 3) Seoladh, 4) comhad teicniúil, 5) Déantóir an innill a thuariscítear thíos, 6) Dearbhaíonn sé go bhfuil an t-inneall, 7) Go gcoíonn sé le na teoracha seo a leanas agus a trasuimh isteach i ndlí náisiúnta, 8) Le haghaidh innill an agusín IV, 9) Uimhir teastais, 10) Comhlacht a chuireadh i bhfios, 15) caighdeán comhchuibhíne a úsáidtear, 16) caighdeán eile nó sonraíochtaí teicniúla a úsáidtear, 17) Déanta ag, 18) Dáta, 19) Ainm an tsinitheora, 20) Feidhm, 21) Síniú.

hu : 1) CE megfelelősségi nyilatkozat (eredeti), 2) A vállalat, 3) Cím, 4) műszaki dokumentáció, 5) Az alábbi gép gyártója, 6) Kijelenti, hogy a gép, 7) Megfelel az alábbi irányelveknek valamint azok hozosított előírásainak, 8) A IV. melléklet gépeihez, 9) Bizonylati szám, 10) Értécsített szervezet, 15) felhasznált harmonizált szabványok, 16) egyéb felhasznált műszaki szabványok és előírások hivatkozásai, 17) Kelt (hely), 18) Dátum, 19) Aláíró neve, 20) Funkció, 21) Aláírás.

is : 1) (Samræmisvottorð ESB (upprunalega), 2) Fyrirtækið, 3) Aðsetur, 4) Tæknilegar skrá, 5) Smíður tækisins sem lýst er hér á eftir, 6) Staðfestir að tækið, 7) Samræmist eftirfarandi stöðlum og staðfarslu þeirra með hlöðsön af þjóðarrétti, 8) Fyrir tækin í aukakafla IV, 9) Staðfestingarnúmer, 10) Tilkynnt til, 15) samhæfða staða sem notaðir, 16) önnur staðlar eða forskrifir notað, 17) Staður, 18) Dagsetning, 19) Nafn undirritaðs, 20) Staða, 21) Undirskrift.

it : 1) Dichiarazione CE di conformità (originale), 2) La società, 3) Indirizzo, 4) fascicolo tecnico, 5) Costruttore della macchina descritta di seguito, 6) Dichiara che questa macchina, 7) È conforme alle direttive seguenti e alle relative trasposizioni nel diritto nazionale, 8) Per le macchine Allegato IV, 9) Numero di Attestazione, 10) Organismo notificato, 15) norme armonizzate applicate, 16) altre norme e specifiche tecniche applicate, 17) Stabilita a, 18) Data, 19) Nome del firmatario, 20) Funzione, 21) Firma.

lt : 1) CE atitikties deklaracija (originalas), 2) Bendrovė, 3) Adresas, 4) Techninė byla, 5) Žemiau nurodytas įrenginio gamintojas, 6) Pareiškia, kad šis įrenginys, 7) Atitinka toliau nurodytas direktyvas ir į nacionalinius teisės aktus perkeltas jų nuostatas, 8) IV priedas dėl mašinų, 9) Certifikato Nr, 10) Paskelbtoji įstaiga, 15) suderintus standartus naudojamus, 16) kiti standartai ir techninės specifikacijos, 17) Pasirašyta, 18) Data, 19) Pasirašiusio asmens vardas ir pavardė, 20) Pareigos, 21) Parašas.

lv : 1) EK atbilstības deklarācija (oriģināls), 2) Uzņēmums, 3) Adrese, 4) tehniskās lietas, 5) Tālāk aprakstītās iekārtas ražotājs, 6) Apliecinā, ka šī iekārtā, 7) Ir atbilstoša tālāk norādītajām direktīvām un to transpozīcijai nacionālajā likumdošanā, 8) Iekārtām IV pielikumā, 9) Iekārtas numurs, 10) Reģistrētā organizācija, 15) Lietotajiem saskaņotajiem standartiem, 16) lietotajiem tehniskajiem standartiem un specifikācijām, 17) Sastādīts, 18) Datums, 19) Parakstītāja vārds, 20) Amats, 21) Paraksts.

mt : 1) Dikjarazzjoni ta' Konformità KE (oriġinali), 2) Il-kumpanija, 3) Indirizz, 4) fajl tekniku, 5) Manifattriċi tal-magna deskritta hawn isfel, 6) Tidlikjara li din il-magna, 7) Hija konformi hija konformi mad-Direttivi segwenti u li-ġigijiet li jimplimentawhom fil-ġigji nazzjonali, 8) Għall-magni fl-Anness IV, 9) Numru taċ-certifikat, 10) Entità nnotifikata, 15) li-standardi armonizzati użati, 16) standardi teknici u specifikazzjonijiet oħra użati, 17) Magħmul f', 18) Data, 19) Isem il-firmatarju, 20) Kariga, 21) Firma.

nl : 1) EG-verklaring van overeenstemming (oorspronkelijke), 2) Het bedrijf, 3) Adres, 4) technische dossier, 5) Constructeur van de hierna genoemde machine, 6) Verklaart dat deze machine, 7) In overeenstemming is met de volgende richtlijnen en hun omzettingen in het nationale recht, 8) Voor machines van bijlage IV, 9) Goedgekeuringsnummer, 10) Aangezegde instelling, 15) gehanteerde geharmoniseerde normen, 16) andere gehanteerde technische normen en specificaties, 17) Opgemaakt te, 18) Datum, 19) Naam van ondergetekende, 20) Functie, 21) Handtekening.

no : 1) CE-samsvarserklæring (original), 2) Selskapet, 3) Adresse, 4) tekniske arkiv, 5) Fabrikant av følgende maskin, 6) Erklærer at denne maskinen, 7) Oppfyller kravene i følgende direktiver, med nasjonale gjennomføringsbestemmelser, 8) For maskinene i tillegg IV, 9) Attestnummer, 10) Notifisert organ, 15) harmoniserte standarder som brukes, 16) Andre standarder og spesifikasjoner brukt, 17) Utstedt i, 18) Dato, 19) Underskriverens navn, 20) Stilling, 21) Underskrift.

pl : 1) Deklaracja zgodności CE (oryginalne), 2) Spółka, 3) Adres, 4) dokumentacja technicznej, 5) Wykonawca maszyny opisanej poniżej, 6) Oświadczka, że ta maszyna, 7) Jest zgodna z następującymi dyrektywami i odpowiadającymi przepisami prawa krajowego, 8) Dla maszyn załącznik IV, 9) Numer certyfikatu, 10) Jednostka certyfikująca, 15) zastosowanych norm zharmonizowanych, 16) innych zastosowanych norm technicznych i specyfikacji, 17) Sporządzono w, 18) Data, 19) Nazwisko podpisującego, 20) Stanowisko, 21) Podpis.

pt : 1) Declaração de conformidade CE (original), 2) A empresa, 3) Morada, 4) processo técnico, 5) Fabricante da máquina descrita abaixo, 6) Declara que esta máquina, 7) Está em conformidade às diretrizes seguintes e às suas transposições para o direito nacional, 8) Para as máquinas no anexo IV, 9) Número de certificado, 10) Entidade notificada, 15) normas harmonizadas utilizadas, 16) outras normas e especificações técnicas utilizadas, 17) Elaborado em, 18) Data, 19) Nome do signatário, 20) Cargo, 21) Assinatura.

ro : 1) Declarație de conformitate CE (originală), 2) Societatea, 3) Adresa, 4) cârtili tehnice, 5) Constructor al mașinii descrise mai jos, 6) Declară că prezenta mașină, 7) Este conformă cu directivele următoare și cu transpunerea lor în dreptul național, 8) Pentru mașinile din anexa IV, 9) Număr de atestare, 10) Organism notificat, 15) standardele armonizate utilizate, 16) alte standarde și specificații tehnice utilizate, 17) Intocmit la, 18) Data, 19) Numele persoanei care semnează, 20) Funcția, 21) Semnătura.

sk : 1) ES vyhlásenie o zhode (pôvodný), 2) Názov spoločnosti, 3) Adresa, 4) technickej dokumentácie, 5) Výrobca nižšie opísaného stroja, 6) Vyhlasuje, že tento stroj, 7) Je v súlade s nasledujúcimi smernicami a smernicami transponovanými do vnitrostátného práva, 8) Pre stroje v prílohe IV, 9) Číslo certifikátu, 10) Notifikačný orgán, 15) použité harmonizované normy, 16) použité iné technické normy a predpisy, 17) Miesto vydania, 18) Dátum vydania, 19) Meno podpisujúceho, 20) Funkcia, 21) Podpis.

sl : 1) ES Izjava o ustreznosti (izvirna), 2) Družba, 3) Naslov, 4) tehnične dokumentacije, 5) Proizvajalac tukaj opisanega stroja, 6) Izjavlja, da je ta stroj, 7) Ustreza naslednjim direktivam in njihovi transpoziciji v državno pravo, 8) Za stroje priloga IV, 9) Številka potrdila, 10) Obvestilo organu, 15) uporabljene harmonizirane standarde, 16) druge uporabljene tehnične standarde in zahteve, 17) V, 18) Datum, 19) Ime podpisnika, 20) Funkcija, 21) Podpis.

sv : 1) CE-försäkran om överensstämmelse (original), 2) Företaget, 3) Adress, 4) tekniska dokumentationen, 5) Konstruktor av nedan beskrivna maskin, 6) Försäkrar att denna maskin, 7) Överensstämmer med nedanstående direktiv och införlivandet av dem i nationell rätt, 8) För maskinerna i bilaga IV, 9) Nummer för godkännande, 10) Organism som underrättats, 15) Harmoniserade standarder som använts, 16) andra tekniska standarder och specifikationer som använts, 17) Upprättat i, 18) Datum, 19) Namn på den som undertecknat, 20) Befattning, 21) Namnteckning.

CE DECLARATION OF CONFORMITY (TRACTOR TYPE APPROVAL)

This document is a specimen of the CE Declaration of Conformity and includes the contents of the original declaration supplied with the machine.

This specimen and the original document may contain fields that are not applicable to your machine. These fields are left blank if not applicable.

Refer to the original Declaration of Conformity for all data applicable to your machine.

1) **DÉCLARATION «CE» DE CONFORMITÉ (originale)** **«EC» DECLARATION OF CONFORMITY (original)**

2) Constructeur, *Manufacturer* : **MANITOU BF**

3) Adresse, *Address* : **430, RUE DE L'AUBINIÈRE - B.P 10249
44158 - ANCENIS - CEDEX - FRANCE**

4) Titulaire du dossier technique, *Holder of the technical file* : **MANITOU BF**

3) Adresse, *Address* : **430, RUE DE L'AUBINIÈRE - B.P 10249
44158 - ANCENIS - CEDEX - FRANCE**

5) Le constructeur déclare que la machine décrite ci-après, *The manufacturer declares that the machine described below* :

Permanently mounted equipment for telescopic loader tractor type T1a

MLT630 115D ST5 S1

6) Est conforme aux directives suivantes et à leurs transpositions en droit national (si applicables),
Complies with the following directives and their transpositions into national law (if applicable) :

2006/42/CE

7) Pour les machines annexe IV, *For annex IV machines* : **Non applicable**

8) Numéro d'attestation, *Certificate number* : **Non applicable**

9) Organisme notifié, *Notified body* : **Non applicable**

10) Procédure appliquée, *Applied procedure* :

9) Organisme notifié, *Notified body* :

11) Niveau de puissance acoustique, *Sound power level* :

12) Mesuré, *Measured* : dB (A)

13) Garanti, *Guaranteed* : dB (A)

2014/30/UE

14) Normes harmonisées utilisées, *Harmonised standards used* :

EN1459 ; EN 12895

15) Normes ou dispositions techniques utilisées, *Standards or technical provisions used* :

16) Fait à, *Done at* :

17) Date, *Date* :

18) Nom du signataire, *Name of signatory* :

19) Fonction, *Function* :

20) Société, *Company* :

21) Signature, *Signature* :

bg : 1) удостоверение за « CE » съответствие (оригинална), 2) Фирмата, 3) Адрес, 4) Техническо досие, 5) Фабрикант на описаната по-долу машина, 6) Обявява, че тази машина, 7) товара на следните директиви и на тяхното съответствие национално право, 8) За машините към допълнение IV, 9) Номер на удостоверението, 10) Наименована фирма, 15) хармонизирани стандарти използвани, 16) стандарти или технически правила, използвани, 17) Изработено в, 18) Дата, 19) Име на разписалия се, 20) Функция, 21) Функция.

cs : 1) ES prohlášení o shodě (původní), 2) Název společnosti, 3) Adresa, 4) Technická dokumentace, 5) Výrobce níže uvedeného stroje, 6) Prohlašuje, že tento stroj, 7) Je v souladu s následujícími směrnicemi a směrnicemi transponovanými do vnitrostátního práva, 8) Pro stroje v příloze IV, 9) Číslo certifikátu, 10) Notifikační orgán, 15) harmonizované normy použité, 16) Norem a technických pravidel používaných, 17) Místo vydání, 18) Datum vydání, 19) Jméno podepsaného, 20) Funkce, 21) Podpis.

da : 1) EF Overensstemmelseserklæring (original), 2) Firmaet, 3) Adresse, 4) tekniske dossier, 5) Konstruktor af nedenfor beskrevne maskine, 6) Erklærer, at denne maskine, 7) Overholder nedennævnte direktiver og disses gennemførelse til national ret, 8) For maskiner under bilag IV, 9) Certifikat nummer, 10) Bemyndigede organ, 15) harmoniserede standarder, der anvendes, 16) standarder eller tekniske regler, 17) Udfærdiget i, 18) Dato, 19) Underskrivers navn, 20) Funktion, 21) Underskrift.

de : 1) EG-Konformitätserklärung (original), 2) Die Firma, 3) Adresse, 4) Technischen Unterlagen, 5) Hersteller der nachfolgend beschriebenen Maschine, 6) Erklärt, dass diese Maschine, 7) den folgenden Richtlinien und deren Umsetzung in die nationale Gesetzgebung entspricht, 8) Für die Maschinen laut Anhang IV, 9) Bescheinigungsnummer, 10) Benannte Stelle, 15) angewandten harmonisierten Normen, 16) angewandten sonstigen technischen Normen und Spezifikationen, 17) Ausgestellt in, 18) Datum, 19) Name des Unterzeichners, 20) Funktion, 21) Unterschrift.

el : 1) Δήλωση συμμόρφωσης CE (πρωτότυπο), 2) Η εταιρεία, 3) Διεύθυνση, 4) τεχνικό φάκελο, 5) Κατασκευάστρια του εξής περιγραφόμενου μηχανήματος, 6) Δηλώνει ότι αυτό το μηχάνημα, 7) Είναι σύμφωνο με τις εξής οδηγίες και τις προσαρμογές τους στο εθνικό δίκαιο, 8) Για τα μηχανήματα παραρτήματος IV, 9) Αριθμός δήλωσης, 10) Κοινοποιημένος φορέας, 15) εναρμονισμένα πρότυπα που χρησιμοποιούνται, 16) Πρότυπα ή τεχνικούς κανόνες που χρησιμοποιούνται, 16) Είναι σύμφωνο με τα εξής πρότυπα και τεχνικές διατάξεις, 17) Έν, 18) Ημερομηνία, 19) Όνομα του υπογράφοντος, 20) Θέση, 21) Υπογραφή.

es : Declaración DE de conformidad (original), 2) La sociedad, 3) Dirección, 4) expediente técnico, 5) Constructor de la máquina descrita a continuación, 6) Declara que esta máquina, 7) Esté conforme a las siguientes directivas y a sus transposiciones en derecho nacional, 8) Para las máquinas anexo IV, 9) Número de certificación, 10) Organismo notificado, 15) normas armonizadas utilizadas, 16) Otras normas o especificaciones técnicas utilizadas, 17) Hecho en, 18) Fecha, 19) Nombre del signatario, 20) Función, 21) Firma.

et : 1) EÜ vastavusdeklaratsioon (algupärane), 2) Äriühing, 3) Aadress, 4) Tehniline dokumentatsioon, 5) Seadme tootja, 6) Kinnitab, et see toode, 7) On vastavuses järgmiste direktiivide ja nende riigisisesesse õigusesse ülevõtmiseks vastuvõetud õigusaktidega, 8) IV lisas loetletud seadmete puhul, 9) Tunnistuse number, 10) Tunnistuse number, 15) kasutatud ühtlustatud standardite, 16) Muud standardites või spetsifikatsioonides kasutatakse, 17) Väljaandmise koht, 18) Väljaandmise aeg, 19) Alkiriastaja nimi, 20) Amet, 21) Alkiri.

fi : 1) EY-vaatimustenmukaisuusvakuutus (alkuperäiset), 2) Yritys, 3) Osoite, 4) teknisen eritelmän, 5) Jäljessä kuvattu koneen valmistaja, 6) Vakuuttaa, että tämä kone, 7) Täyttää seuraavien direktiivien sekä niitä vastaavien kansallisten säännösten vaatimukset, 8) Liitteen IV koneiden osalta, 9) Todistuksen numero, 10) Ilmoitettu laitos, 15) yhdenmukaistettuja standardeja käytetään, 16) muita standardeja tai eritelmiä, 17) Paikka, 18) Aika, 19) Allekirjoittajan nimi, 20) Toimi, 21) Allekirjoitus.

ga : 1) « CE » dearbhú comhréireachta (bunaidh), 2) An comhlacht, 3) Seoladh, 4) comhad teicniúil, 5) Déantóir an innill a thuariscítear thíos, 6) Dearbhaionn sé go bhfuil an t-inneall, 7) Go gcoinnn sé le na teoracha seo a leanas agus a trasuimh isteach i ndlí náisiúnta, 8) Le haghaidh innill an agusín IV, 9) Uimhir teastais, 10) Comhlacht a chuireadh i bhfios, 15) caighdeán comhchuibhíne a úsáidtear, 16) caighdeán eile nó sonraíochtaí teicniúla a úsáidtear, 17) Déanta ag, 18) Dáta, 19) Ainm an tsinitheora, 20) Feidhm, 21) Síniú.

hu : 1) CE megfelelősségi nyilatkozat (eredeti), 2) A vállalat, 3) Cím, 4) műszaki dokumentáció, 5) Az alábbi gép gyártója, 6) Kijelenti, hogy a gép, 7) Megfelel az alábbi irányelveknek valamint azok hozosított előírásainak, 8) A IV. melléklet gépeihez, 9) Bizonylati szám, 10) Értécsített szervezet, 15) felhasznált harmonizált szabványok, 16) egyéb felhasznált műszaki szabványok és előírások hivatkozásai, 17) Kelt (hely), 18) Dátum, 19) Aláíró neve, 20) Funkció, 21) Aláírás.

is : 1) (Samræmisvottorð ESB (upprunalega), 2) Fyrirtækið, 3) Aðsetur, 4) Tæknilegar skrá, 5) Smíður tækisins sem lýst er hér á eftir, 6) Staðfestir að tækið, 7) Samræmist eftirfarandi stöðlum og staðfarslu þeirra með hlöðsön af þjóðarrétti, 8) Fyrir tækni í aukakafla IV, 9) Staðfestingarnúmer, 10) Tilkynnt til, 15) samhæfða staða sem notaðir, 16) önnur staðlar eða forskrifir notað, 17) Staður, 18) Dagsetning, 19) Nafn undirritaðs, 20) Staða, 21) Undirskrift.

it : 1) Dichiarazione CE di conformità (originale), 2) La società, 3) Indirizzo, 4) fascicolo tecnico, 5) Costruttore della macchina descritta di seguito, 6) Dichiara che questa macchina, 7) È conforme alle direttive seguenti e alle relative trasposizioni nel diritto nazionale, 8) Per le macchine Allegato IV, 9) Numero di Attestazione, 10) Organismo notificato, 15) norme armonizzate applicate, 16) altre norme e specifiche tecniche applicate, 17) Stabilita a, 18) Data, 19) Nome del firmatario, 20) Funzione, 21) Firma.

lt : 1) CE atitikties deklaracija (originalas), 2) Bendrovė, 3) Adresas, 4) Techninė byla, 5) Žemiau nurodytas įrenginio gamintojas, 6) Pareiškia, kad šis įrenginys, 7) Atitinka toliau nurodytas direktyvas ir į nacionalinius teisės aktus perkeltas jų nuostatas, 8) IV priedas dėl mašinų, 9) Certifikato Nr, 10) Paskelbtoji įstaiga, 15) suderintus standartus naudojamus, 16) Kiti standartai ir techninės specifikacijos, 17) Pasirašyta, 18) Data, 19) Pasirašiusio asmens vardas ir pavardė, 20) Pareigos, 21) Parašas.

lv : 1) EK atbilstības deklarācija (oriģināls), 2) Uzņēmums, 3) Adrese, 4) tehniskās lietas, 5) Tālāk aprakstītās iekārtas ražotājs, 6) Apliecinā, ka šī iekārtā, 7) Ir atbilstoša tālāk norādītajām direktīvām un to transpozīcijai nacionālajā likumdošanā, 8) Iekārtām IV pielikumā, 9) Iekārtas numurs, 10) Reģistrētā organizācija, 15) Lietotajiem saskaņotajiem standartiem, 16) lietotajiem tehniskajiem standartiem un specifikācijām, 17) Sastādīts, 18) Datums, 19) Parakstītāja vārds, 20) Amats, 21) Paraksts.

mt : 1) Dikjarazzjoni ta' Konformità KE (oriġinali), 2) Il-kumpanija, 3) Indirizz, 4) fajl tekniku, 5) Manifattriċi tal-magna deskritta hawn isfel, 6) Tidlikjara li din il-magna, 7) Hija konformi hija konformi mad-Direttivi segwenti u l-Igijiet li jimplimentawhom fil-Igji nazzjonali, 8) Għall-magni fl-Anness IV, 9) Numru taċ-certifikat, 10) Entità nnotifikata, 15) l-Istandards armonizzati użati, 16) standards tekniċi u speċifikazzjonijiet oħra użati, 17) Magħmul f, 18) Data, 19) Isem il-firmatarju, 20) Kariga, 21) Firma.

nl : 1) EG-verklaring van overeenstemming (oorspronkelijke), 2) Het bedrijf, 3) Adres, 4) technische dossier, 5) Constructeur van de hierna genoemde machine, 6) Verklaart dat deze machine, 7) In overeenstemming is met de volgende richtlijnen en hun omzettingen in het nationale recht, 8) Voor machines van bijlage IV, 9) Goedkeuringsnummer, 10) Aangezegde instelling, 15) gehanteerde geharmoniseerde normen, 16) andere gehanteerde technische normen en specificaties, 17) Opgemaakt te, 18) Datum, 19) Naam van ondergetekende, 20) Functie, 21) Handtekening.

no : 1) CE-samsvarserklæring (original), 2) Selskapet, 3) Adresse, 4) tekniske arkiv, 5) Fabrikant av følgende maskin, 6) Erklærer at denne maskinen, 7) Oppfyller kravene i følgende direktiver, med nasjonale gjennomføringsbestemmelser, 8) For maskinene i tillegg IV, 9) Attestnummer, 10) Notifisert organ, 15) harmoniserte standarder som brukes, 16) Andre standarder og spesifikasjoner brukt, 17) Utstedt i, 18) Dato, 19) Underskriverens navn, 20) Stilling, 21) Underskrift.

pl : 1) Deklaracja zgodności CE (oryginalne), 2) Spółka, 3) Adres, 4) dokumentacja technicznej, 5) Wykonawca maszyny opisanej poniżej, 6) Oświadczka, że ta maszyna, 7) Jest zgodna z następującymi dyrektywami i odpowiadającymi przepisami prawa krajowego, 8) Dla maszyn załącznik IV, 9) Numer certyfikatu, 10) Jednostka certyfikująca, 15) zastosowanych norm zharmonizowanych, 16) innych zastosowanych norm technicznych i specyfikacji, 17) Sporządzono w, 18) Data, 19) Nazwisko podpisującego, 20) Stanowisko, 21) Podpis.

pt : 1) Declaração de conformidade CE (original), 2) A empresa, 3) Morada, 4) processo técnico, 5) Fabricante da máquina descrita abaixo, 6) Declara que esta máquina, 7) Está em conformidade às diretrizes seguintes e às suas transposições para o direito nacional, 8) Para as máquinas no anexo IV, 9) Número de certificado, 10) Entidade notificada, 15) normas harmonizadas utilizadas, 16) outras normas e especificações técnicas utilizadas, 17) Elaborado em, 18) Data, 19) Nome do signatário, 20) Cargo, 21) Assinatura.

ro : 1) Declarație de conformitate CE (originală), 2) Societatea, 3) Adresa, 4) cârtili tehnice, 5) Constructor al mașinii descrise mai jos, 6) Declară că prezenta mașină, 7) Este conformă cu directivele următoare și cu transpunerea lor în dreptul național, 8) Pentru mașinile din anexa IV, 9) Număr de atestare, 10) Organism notificat, 15) standardele armonizate utilizate, 16) alte standarde și specificații tehnice utilizate, 17) Intocmit la, 18) Data, 19) Numele persoanei care semnează, 20) Funcția, 21) Semnătura.

sk : 1) ES vyhlásenie o zhode (pôvodný), 2) Názov spoločnosti, 3) Adresa, 4) technickej dokumentácie, 5) Výrobca nižšie opísaného stroja, 6) Vyhlasuje, že tento stroj, 7) Je v súlade s nasledujúcimi smernicami a smernicami transponovanými do vnitrostátného práva, 8) Pre stroje v prílohe IV, 9) Číslo certifikátu, 10) Notifikačný orgán, 15) použité harmonizované normy, 16) použité iné technické normy a predpisy, 17) Miesto vydania, 18) Dátum vydania, 19) Meno podpisujúceho, 20) Funkcia, 21) Podpis.

sl : 1) ES Izjava o ustreznosti (izvirna), 2) Družba, 3) Naslov, 4) tehnične dokumentacije, 5) Proizvajalac tukaj opisanega stroja, 6) Izjavlja, da je ta stroj, 7) Ustreza naslednjim direktivam in njihovi transpoziciji v državno pravo, 8) Za stroje priloga IV, 9) Številka potrdila, 10) Obvestilo organu, 15) uporabljene harmonizirane standarde, 16) druge uporabljene tehnične standarde in zahteve, 17) V, 18) Datum, 19) Ime podpisnika, 20) Funkcija, 21) Podpis.

sv : 1) CE-försäkran om överensstämmelse (original), 2) Företaget, 3) Adress, 4) tekniska dokumentationen, 5) Konstruktor av nedan beskrivna maskin, 6) Försäkrar att denna maskin, 7) Överensstämmer med nedanstående direktiv och införlivandet av dem i nationell rätt, 8) För maskinerna i bilaga IV, 9) Nummer för godkännande, 10) Organism som underrättats, 15) Harmoniserade standarder som använts, 16) andra tekniska standarder och specifikationer som använts, 17) Upprättat i, 18) Datum, 19) Namn på den som undertecknat, 20) Befattning, 21) Namnteckning.

UKCA DECLARATION OF CONFORMITY

This document is a specimen of the UKCA Declaration of Conformity and includes the contents of the original declaration supplied with the machine.

This specimen and the original document may contain fields that are not applicable to your machine. These fields are left blank if not applicable.

Refer to the original Declaration of Conformity for all data applicable to your machine.

UKCA DECLARATION OF CONFORMITY

Manufacturer: **MANITOU BF**
Address: **430, RUE DE L'AUBINIÈRE - BP 10249
44158 ANCENIS CEDEX - FRANCE**
Authorized representative: **MANITOU UK
Ebble Industrial Estate - Dorset BH 31 6BB
Verwood - United Kingdom**

The manufacturer declares that the below described machinery:

Rough-terrain variable-reach truck

MLT630 115D ST5 S1

Complies with the following legislation:

The supply of Machinery (Safety) Regulations 2008, as amended

The machine is designed for the lifting of persons:

Applied procedure: Non applicable
Certificate number: Non applicable
Dated:
Approved body: Non applicable

**Noise Emission in the Environment by Equipment
for use Outdoors Regulations 2001, as amended**

Applied procedure: Schedule 11
Approved body: SNCH
11 ROUTE DU LUXEMBOURG
5201 SANDWEILER - LUXEMBOURG

Sound power level:

Measured: dB (A)
Guaranteed: dB (A)

Electromagnetic Compatibility Regulations 2016, as amended

The following designated standards have been addressed:

EN1459 ; EN 12895

The following standards or technical guidance have been addressed:

At: Date:
Name of signatory:
Position:
Company:
Signature:

UKCA DECLARATION OF CONFORMITY (TRACTOR TYPE APPROVAL)

This document is a specimen of the UKCA Declaration of Conformity and includes the contents of the original declaration supplied with the machine.

This specimen and the original document may contain fields that are not applicable to your machine. These fields are left blank if not applicable.

Refer to the original Declaration of Conformity for all data applicable to your machine.

UKCA DECLARATION OF CONFORMITY

Manufacturer: **MANITOU BF**
Address: **430, RUE DE L'AUBINIÈRE - BP 10249
44158 ANCENIS CEDEX - FRANCE**
Authorized representative: **MANITOU UK
Ebblake Industrial Estate - Dorset BH 31 6BB
Verwood - United Kingdom**

The manufacturer declares that the below described machinery:
**Permanently mounted equipment for telescopic loader tractor type T1a
MLT630 115D ST5 S1**

Complies with the following legislation:

The supply of Machinery (Safety) Regulations 2008, as amended

The machine is designed for the lifting of persons:

Applied procedure: Non applicable
Certificate number: Non applicable
Dated:
Approved body: Non applicable

Applied procedure:
Approved body:

Sound power level:

Measured: dB (A)
Guaranteed: dB (A)

Electromagnetic Compatibility Regulations 2016, as amended

The following designated standards have been addressed:

EN1459 ; EN 12895

The following standards or technical guidance have been addressed:

At: Date:
Name of signatory:
Position:
Company:
Signature:



(1) Certificate

(2) No. of the Certificate: **BVS 13 H 053 X**
(3) Product: **Particle filter as specified in 14 as spark arrester according to EN 1834**
(4) Manufacturer: **DEUTZ AG**
(5) Address: **Ottostrasse 1
51149 Köln
Germany**

- (6) The design of this product and any acceptable variation thereto are specified in the appendix to this certificate.
- (7) The certification body of DEKRA EXAM GmbH certifies that this product comply with the requirements of the test regulations listed under item 8 below. The test results are recorded in the test and assessment report 13 EXAM 11097 BVS-Fr.
- (8) The requirements of the standard are assured by compliance with
DIN EN 1834-1:2000; Chapter 6.4.2
DIN EN 1834-2:2000; Chapter 6.4.2
DIN EN 1834-3:2000; Chapter 6.3.2
- (9) This Certificate relates only to the design and tests of the specified product in accordance to the test regulations. Further requirements apply to the manufacturing process and supply of this product. These are not covered by this certificate.

DEKRA EXAM GmbH
Bochum, 2014-09-04



Certification body



Special services unit



- (12) Appendix to
- (13) Certificate BVS 13 H 053 X
- (14) 14.1 Subject and Type

Particle filters with the DEUTZ-part numbers 4600864, 4604124, 4601585, 4601448, 4601586, 4601449, 4601505, 4601501, 4601502, 4601503, 4601445, 4601444, 4604059, 4604048, 4603078, 4603083, 4603088, 4603040, 4603044, 662982, 662862 and 662865. These particle filters are used in combination with diesel engines with turbo charger and oxidations catalysts according to table 1.

Table 1: Combinations of particle filters, diesel engines with turbo charger and oxidations catalysts

Motor Type	Engine Code	Particle Filter	Size	Oxidation Catalyst
TCD2 9L4	C4EI**	4600864	5,06"x9,5"	4600862
TCD3 8L4				
TCD2 9L4	C4EI**	4604124	5,06"x9,5"	4600862
TCD3 8L4				
TCD4 1L4	C4EI**	4601585	8,5"x7"	4601583
TCD4 1L4	C4FI**	4601448	8,5"x7"	4601446
TCD4 1L4	C4EI**	4601586	8,5"x8,5"	4601583
TCD4 1L4	C4FI**	4601449	8,5"x8,5"	4601446
TCD6 1L6	C4EI**	4601505	9,5"x8"	4601504
TCD6 1L6	C4FI**	4601501	9,5"x8"	4601500
TCD6 1L6	C4EI**	4601502	9,5"x10"	4601500
TCD6 1L6	C4FI**	4601503	9,5"x12"	4601500
TCD7 8L6	C4FI**	4601445	11,25"x10"	4601443
TCD7 8L6	C4EI**	4601444	11,25"x12"	4601443
TCD3 8L4	CFV***	4604069	8,5"x7"	4604047
TCD4 1L4	CFV***	4604048	8,5"x8,5"	4604047
TCD6 1L6	CFV***	4603078	9,5"x8"	4603073
TCD6 1L6	CFV***	4603083	9,5"x10"	4603073
TCD6 1L6	CFV***	4603088	9,5"x12"	4603073
TCD7 8L6	CFV***	4603040	11,25"x10"	4603033
TCD7 8L6	CFV***	4603044	11,25"x12"	4603033
TCD6 1L6	CFW***	662982	11,25"x8"	n.a
TTCD6 1L6	CFW***	662862	11,25"x10"	n.a
TTCD7 8L6	CFW***	662865	11,25"x14"	n.a

n. a.: not applicable. These types are not used in combination with separate oxidation catalysts. The inlet of these particle filter variants are catalytically coated.

14.2 Description

The particle filters are used to retain soot particles in exhaust fumes of diesel engines. They consist of a ceramic honeycomb body, an oxidation catalyst and a metallic housing with thermal isolation. The exhaust fumes coming from engine enter the metallic housing via the inlet, pass the oxidation catalyst and enter the honeycomb body, where they penetrate ceramic, porous walls (thickness 0.30 mm) of the cells. The particle filters and the honeycomb body can have different diameters and lengths, but the cell density is 310·10³ cells/m³ for all sizes. The inlet can be axial, perpendicular or with an angle of 45°.

The particle filters were successfully tested according to DIN EN 1834-1:2000, Chapter 6.4.2, DIN EN 1834-2:2000, Chapter 6.4.2 and DIN EN 1634-3:2000, Chapter 6.3.2. The particle filters fulfil the requirements as spark arrester according to DIN EN 1834.

Page 2 of 3 to BVS 13 H 053 X
This certificate may only be published in its entirety and without any change
DEKRA EXAM GmbH, Demandtstraße 9 · 44809 Bochum, telephone: +49 234 3696-100, fax: +49 234 3696-110, ez-exam@dekra.com

14.3 Parameters

Table 2: Operation parameters of particle filters

Part number	Size	Motor Type	Max. Power	Specific Load	Max. exhaust fumes temperature [°C]
			[kW]	[kW/m ³]	
4600864	5,06"x9,5"	TCD2 9L4 TCD3 8L4	90	24,77	530
4604124	5,06"x9,5"	TCD2 9L4 TCD3 8L4	90	24,77	530
4601585	8,5"x7"	TCD4 1L4	95	15,74	450
4601448	8,5"x7"	TCD4 1L4	95	15,24	450
4601586	8,5"x8,5"	TCD4 1L4	115	16,69	530
4601449	8,5"x8,5"	TCD4 1L4	115	16,69	530
4601505	9,5"x8"	TCD6 1L6	130	15,08	450
4601501	9,5"x8"	TCD6 1L6	130	15,08	450
4601502	9,5"x10"	TCD6 1L6	180	14,85	565
4601503	9,5"x12"	TCD6 1L6	180	13,92	570
4601445	11,25"x10"	TCD7 8L6	200	13,24	500
4601444	11,25"x12"	TCD7 8L6	250	13,79	560
4604069	8,5"x7"	TCD3 8L4	97	16,07	530
4603078	8,5"x8,5"	TCD4 1L4	130	15,08	500
4603083	9,5"x8"	TCD6 1L6	150	14,85	520
4603088	9,5"x10"	TCD6 1L6	150	13,62	540
4603040	9,5"x12"	TCD6 1L6	280	17,21	540
4603044	11,25"x10"	TCD7 8L6	280	14,34	540
4604048	11,25"x12"	TCD7 8L6	120	16,37	530
662982	11,25"x8"	TCD6 1L6	174	14,40	520
662862	11,25"x10"	TTCD6 1L6	211	13,97	540
662865	11,25"x14"	TTCD7 8L6	297	13,76	520

- (15) Test and Assessment Report
13 EXAM 11097 BVS-Fr, 2014-09-03
- (16) Special Conditions for Safe Use

The particle filters can only be used as spark arresters in combination with the diesel engines with turbo charger and oxidations catalysts given in table 1.

The function of the particle filters as spark arresters according to DIN EN 1634 was only tested for operation conditions without thermal regeneration of the particles filters. The regeneration of the particle filters is not permitted in hazardous areas.

Page 2 of 3 to BVS 13 H 053 X
This certificate may only be published in its entirety and without any change
DEKRA EXAM GmbH, Demandtstraße 9 · 44809 Bochum, telephone: +49 234 3696-100, fax: +49 234 3696-110, ez-exam@dekra.com

SAFETY PLATES AND STICKERS

⚠ IMPORTANT ⚠

Clean all stickers and safety plates so that they are legible.
Any safety plates and stickers which are illegible or damaged must be replaced.
Check that stickers and safety plates are present after replacing any spare parts.

EXTERNAL PLATES AND STICKERS

REF.	REFERENCE	DESCRIPTION
1	24653	- Slings point
2	52563320	- Tie-down point
3	289013	- Towing instruction
4	234798	- Hydraulic fluid
5	296998	- Maniscopic safety instruction
6	234805	- Hydraulic coupling instruction
7	305405	- Diesel fuel
8	52576441	- Battery cut-off instruction
9	52518055	- Battery troubleshooting
10	52582287	- Caution, hot surface
11	288174	- Accumulator instructions
12	52567646	- Emergency exit
13	250707	- Ventilation reversal
14	52705448	- Hydraulic jack location
15	207525	- Hydraulic towing hook (OPTION)
16	310025	- Hydraulic towing hook visibility (OPTION)
17	52551668	- Air conditioning (OPTION)
18	289625	- Easy attachment connection (OPTION)
19	256513	- Boom electrical predisposition (OPTION)
20	676079	- Towing hook crushing hazard (OPTION)

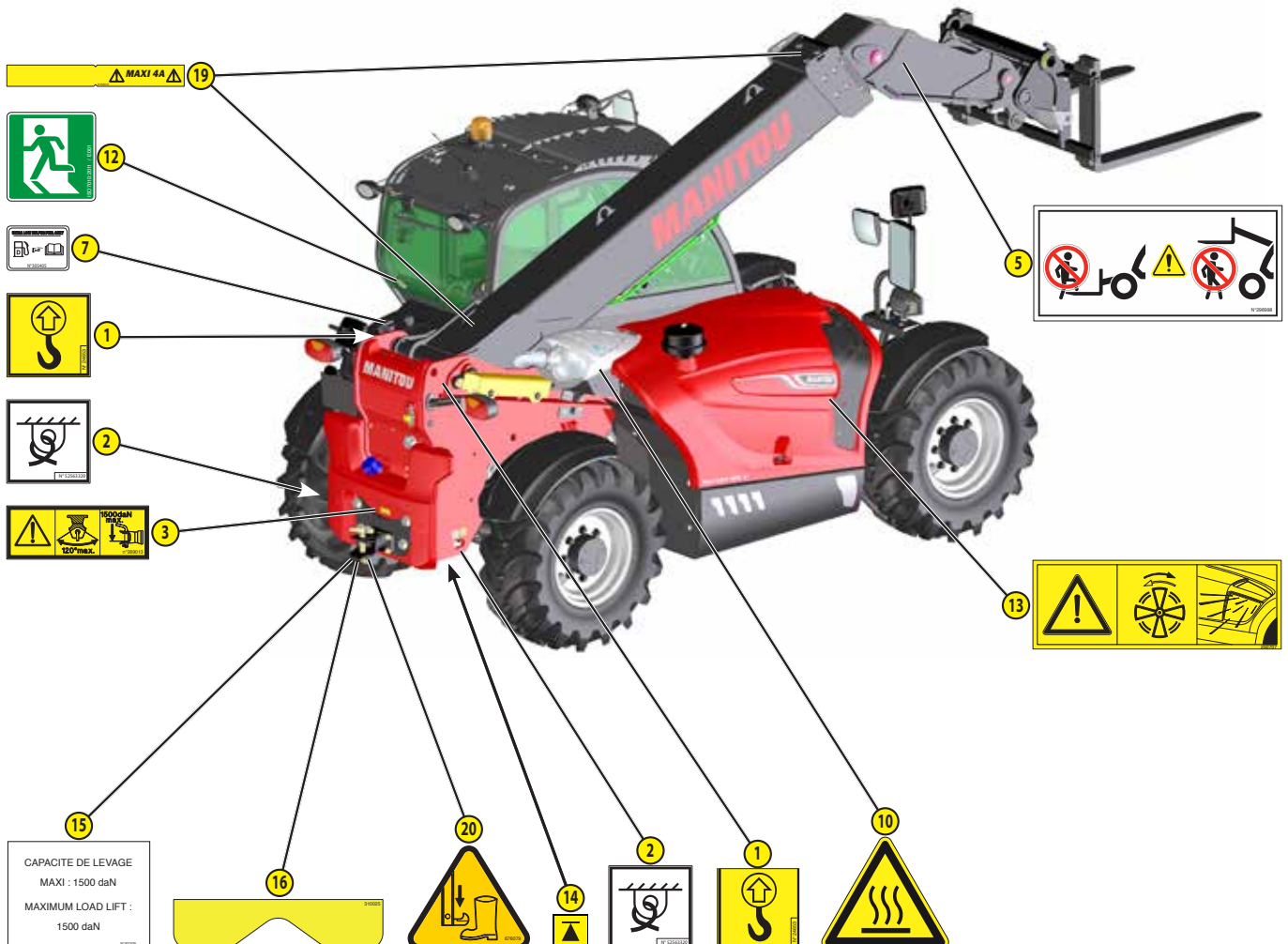

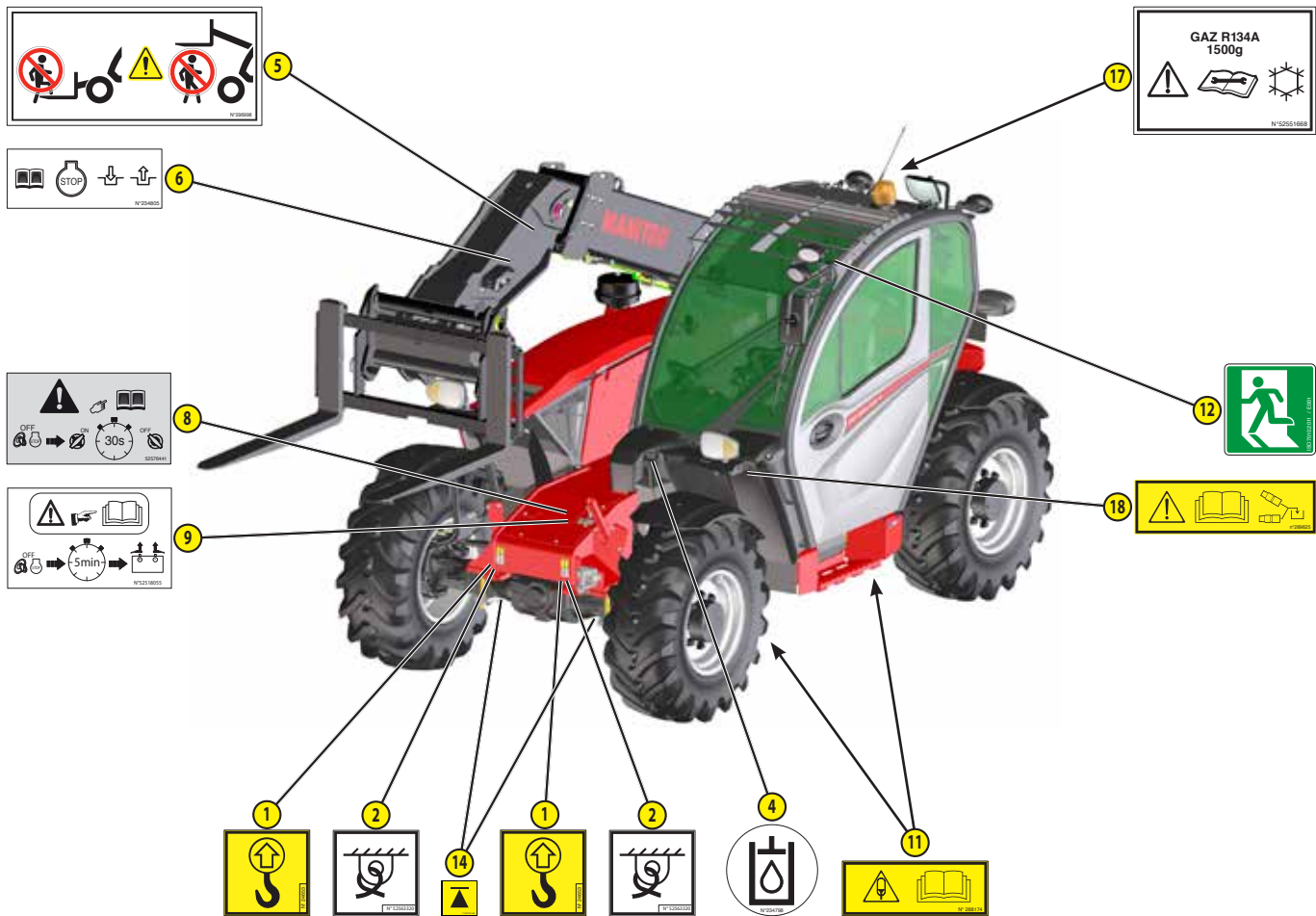

STICKERS AND PLATES UNDER THE ENGINE HOOD

REF.	REFERENCE	DESCRIPTION
1	52515083	- Anti-freeze
2	259398	- Water/diesel separator
3	52710743	- Engine fuse
4	716906	- Fan hazard
5	233088	- Preheat rod (OPTION)

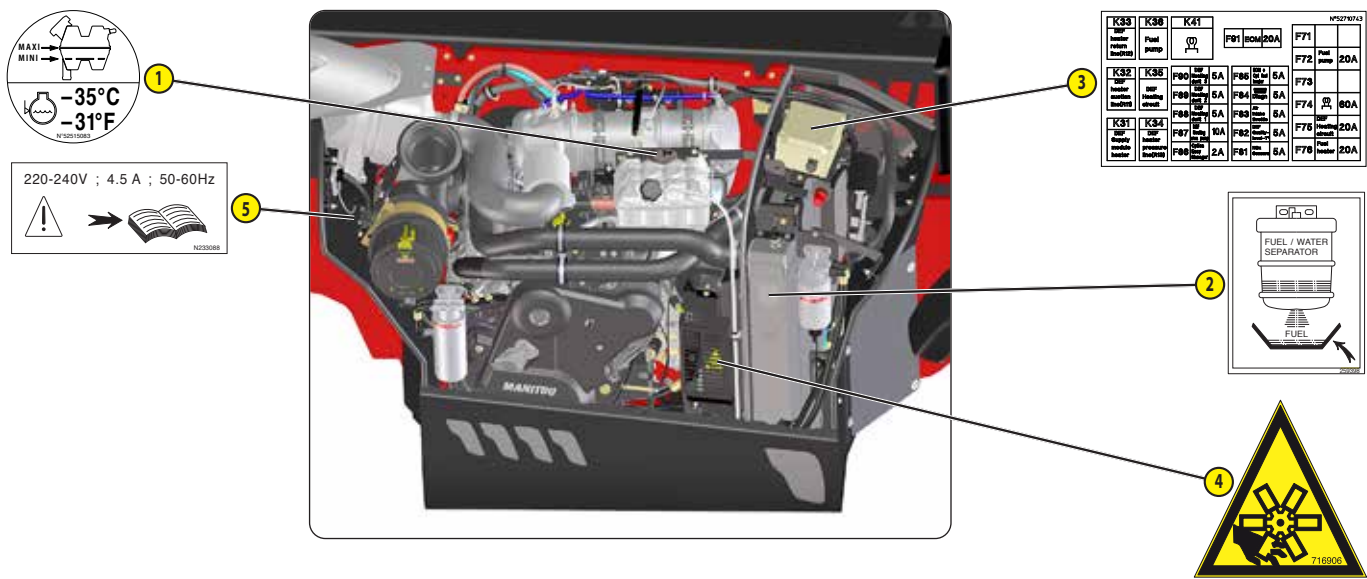

PLATES AND STICKERS IN THE CAB

REF.	REFERENCE	DESCRIPTION
1	52633607	- Cab compliance
2	223324	- Patents
3	52651762	- Hydraulic controls activation
4	52579106	- Cab category 1
5	52633606	- Cab homologation
6	239596	- Sound power level 106dB
7	52643439	- Steering selection control
8	290183	- Bucket instruction on telescope
9	52553499	- Operating mode management instruction
10	52702658	- Fuses
11	52544967	- Switch pictograms
12	52699411	- Reach chart sheet
13	241621	- Safety instruction
14	52655274	- "Stationary lift truck" exhaust regeneration
15	255968	- Joystick function
16	52553495	- Transmission cut-off switch function
17	52545464	- Gear lever
18	52696521	- Tyres
19	52696052	- Hydraulic attachment locking function (OPTION)
20	52674430	- Boom head electrovalve function (OPTION)
21	52697003	- Hydraulic attachment locking + boom head electrovalve function (OPTION)
22	52702742	- Double-acting rear hydraulic control predisposition function (OPTION)
23	52709999	- Hydraulic towing hook control function (OPTION)
24	52705395	- Hydraulic towing hook control + double-acting rear hydraulic predisposition function (OPTION)
25	204079	- Hydraulic towing hook (OPTION)
25	52759172	- WARNING risk of misuse (For UK only)

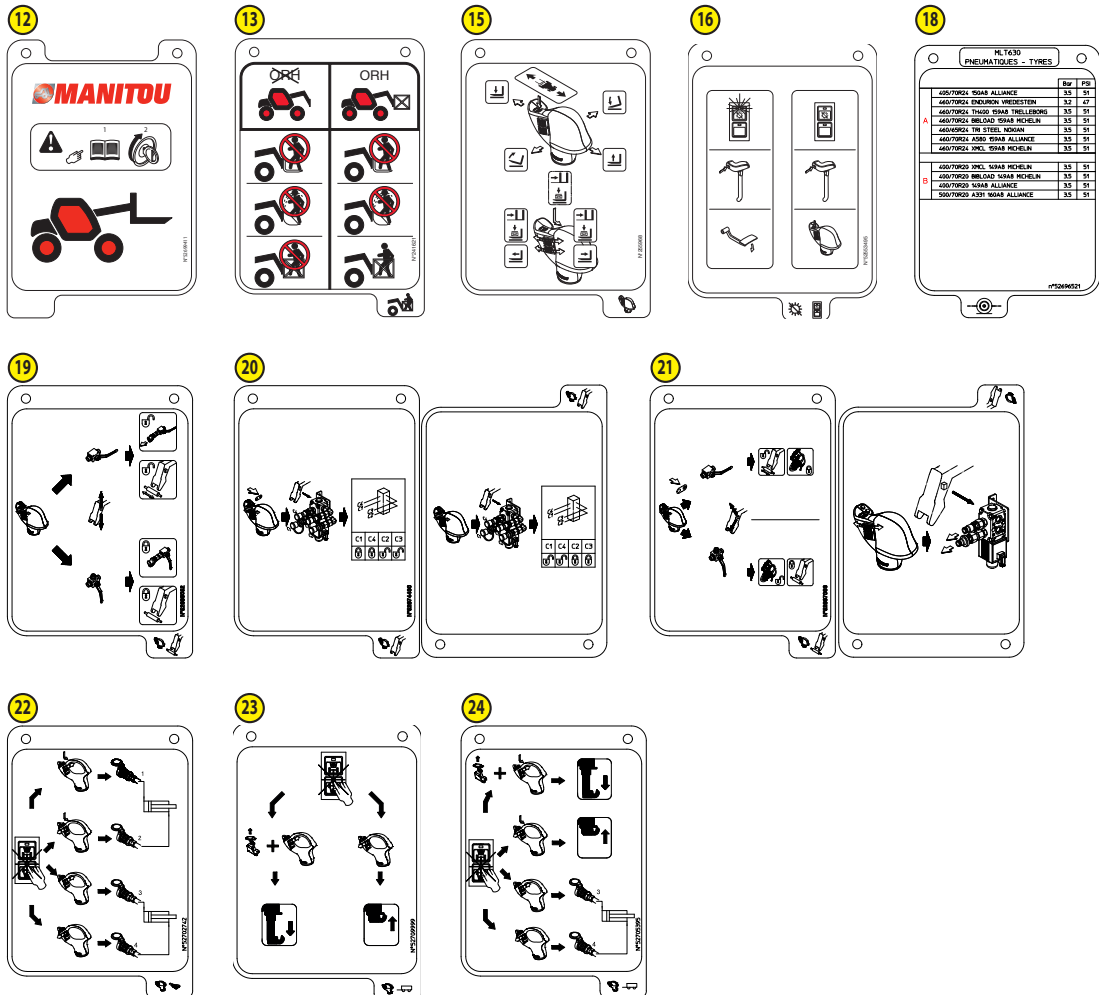

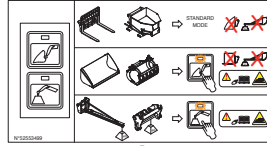
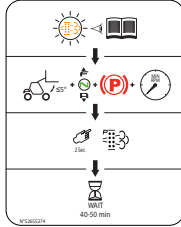
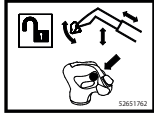
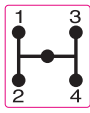

17

3

14

11

9

8

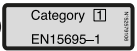
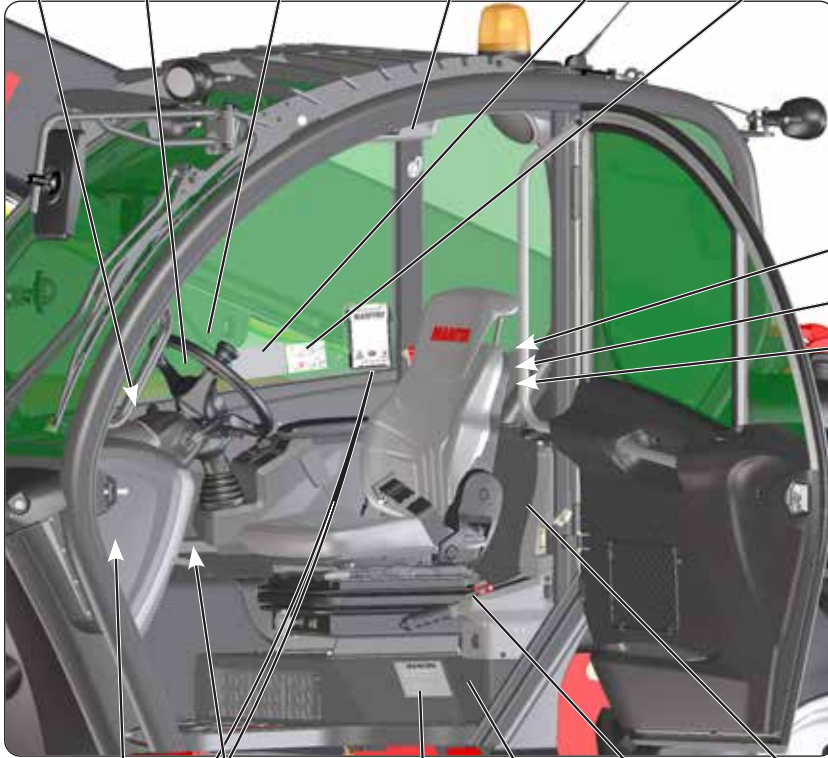

5

4

2

25

25

1

6

7

10

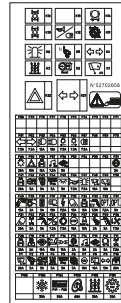
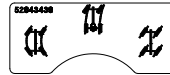
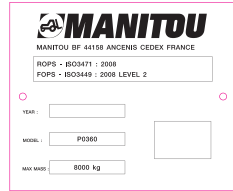

IDENTIFICATION OF THE LIFT TRUCK

As our policy is to promote a constant improvement in our products, our range of lift trucks may undergo certain modifications, without any obligation for us to advise our customers.

When you order parts, or when you require any technical information, always specify the following information.

N.B.: For the owner's convenience, it is recommended that these numbers be entered in the spaces provided, at the time of the delivery of the lift truck.

For any further technical information regarding your lift truck, refer to: SPECIFICATIONS.

LIFT TRUCK MANUFACTURER'S PLATE

"Designation" Designation	
"Series" Series	
"Year of manufacture" Year of manufacture	
"Model year" Model year	
"Serial Number / Product Identification Number" Serial number / Product Identification Number	
"Unladen mass" Unladen weight	
"Power" Power	
"Authorized gross vehicle weight" Authorized gross vehicle weight	
"Rated capacity" Rated capacity	
"Max vertical force (on trailer hook)" Maximum vertical force (on trailer hook)	
"Drag strain" Tractive force	



TRACTOR TYPE APPROVAL PLATE

"Category" Category	
"Homologation N°" Certification number	
"Product Identification Number" Product identification number	
"Total permissible mass" Maximum laden weight technically permissible	
"Maximum mass on front axle" Maximum weight on front axle	
"Maximum mass on rear axle" Maximum weight on rear axle	
"PERMISSIBLE TOWABLE MASS" PERMISSIBLE TRAILER WEIGHT	
• "B-1 unbraked" unbraked	
• "B-2 inertia braked" inertia braked	
• "B-3 hydraulic braque" hydraulic braked	
• "B-4 pneumatic braked" pneumatic braked	
• "T-1 drawbar" drawbar	
• "T-2 rigid drawbar" rigid drawbar	
• "T-3 centreaxle" center axle	



ENGINE

"MODEL" Model	
"CODE" Code	
"E1" Identification	
"SERNO" Serial number	
"SPEC" Specification	



GEARBOX

MANITOU reference	
Type	
Serial number	



ANGLE GEAR-BOX

Code	
MANITOU reference	
Supplier part number	
Fabrication Date	



FRONT AXLE

Type	
Serial number	
MANITOU reference	



REAR AXLE

Type	
Serial number	
MANITOU reference	

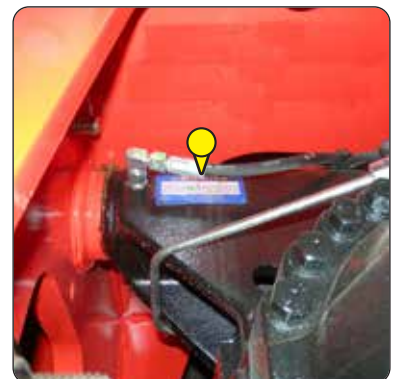

CAB

"Constructeur" Manufacturer	
"Type Cabine" Cab type	
"Numéro de série" Serial number	



BOOM

MANITOU reference	
Date of manufacture and manufacturer	



CHASSIS

Serial number / Product Identification Number	
---	--



ATTACHMENT MANUFACTURER'S PLATE

"MODELE" Model	
"N° série" Serial number	
"Année Fabrication" Year of manufacture	
"Masse à vide" Unladen weight	
"Centre de gravité" Center of gravity	
"Capacité Nominale" Rated capacity	
"Pression service" Working pressure	



SPECIFICATIONS

ENGINE		
Type		DEUTZ TCD3,6L4/CSVI85E
Fuel		Diesel
Number of cylinders		4 in line
Suction		Supercharged
Injection system		Direct
Ignition sequence		1.3.4.2
Displacement	cm ³	3621
Bore and stroke	mm	98 x 120
Compression ratio		17,2
Nominal speed laden	rpm	2200
Min. rpm unladen	rpm	930
Max. rpm unladen	rpm	2360
Power ISO/TR 14396	hp - kW	116 - 85
Power SAE J 1995	hp - kW	116 - 85
Maximum torque ISO/TR 14396	Nm	460 at 1,600 rpm
Air filtration efficiency	%	99,9
Type of cooling		Water/Air
Fan		Suction

TRANSMISSION		
Gearbox		TURNER
- Type		Mechanics
- Shuttle lever		Electro-hydraulics
- Torque converter		SACHS
- Number of forward speeds		4
- Number of reverse speeds		4
Angle gearbox		COMER INDUSTRIES
Front axle		DANA
- Differential		Limited slip
Rear axle		DANA
- Differential		Without locking
Drive wheels		Permanent 4 WD
- 2/4 wheel drive control		no
Front tires		ALLIANCE
- Size		405/70R24 580 150A8
- Pressure	bar	3,5
Rear tires		ALLIANCE
- Size		405/70R24 580 150A8
- Pressure	bar	3,5

ELECTRIC CIRCUIT		
Battery		12 V - 180 Ah - 900 A EN
Alternator		14 V - 120 A
- Type		ISKRA AAK3869
Starter		12 V - 4 kW
- Type		MAHLE AZF4814

BRAKE SYSTEM		
Service brake		Hydraulic power brake
- Type of brake		Oil-immersed multi-disc
- Type of order		Foot-operated for the front and rear axles
Parking brake		Mechanics
- Type of brake		Oil-immersed multi-disc
- Type of order		Manual

HYDRAULIC CIRCUIT			
Hydraulic pump			
- Type		Gears	
		1st casing	2nd casing
- Displacement	cm ³	45	25
- Max. rating capacity unladen	l/min	106	59
- Flow at 1600 rpm	l/min	72	40
Filtration			
- Back	µm	10	10
- Suction	µm	135	135
Maximum working pressure		250	
- Telescoping circuit	bar	250 / 195	
- Lift circuit	bar	250 / 250	
- Tilt circuit	bar	250 / 195	
- Attachment circuit	bar	250	
- Steering circuit	bar	140	

HYDRAULIC MOVEMENTS			
Longitudinal stability limiter and warning device		Electronics	
Lifting motions (boom retracted)			
- Unladen lifting	s - m/min	6,5 - 38,3	
- Laden lifting	s - m/min	7,7 - 32,3	
- Unladen lowering	s - m/min	4,9 - 50,8	
- Laden lowering	s - m/min	4,8 - 51,9	
Telescoping motions (boom raised)			
- Unladen extending	s - m/min	6 - 20,7	
- Laden extending	s - m/min	6,1 - 21	
- Unladen retracting	s - m/min	5,2 - 24,2	
- Laden retracting	s - m/min	5,2 - 24,2	
Tilting movements			
- Unladen digging	s - °/s	3,3 - 44,2	
- Unladen dump	s - °/s	2,6 - 56,2	

SOUND AND VIBRATION			
Sound pressure level in the driver's cab LpA (according to standard EN 12053)	dB(A)	74 (cab closed); xx (cab open)	
Sound pressure (according to Directive 2009/76)	dB(A)	xx (cab closed); xx (cab open)	
Guaranteed sound power level in the environment LwA (according to Directive 2000/14/EC modified by Directive 2005/88/EC)	dB(A)	105 (measured); 107 (guaranteed)	
Sound level in motion (according to Directive 2009/63)	dB(A)	xx	
Average weighted acceleration on driver's body (according to standard EN 13059)	m/s ²	1,13	
The average weighted acceleration transmitted to the driver's hand/ arm system (according to standard ISO 5349-2)	m/s ²	< 2,5	
Standard seat vibration	m/s ²	xx (lightweight operator); xx (heavyweight operator)	

SPECIFICATIONS AND WEIGHTS

Speed of movement for lift truck in standard configuration on flat ground			
- Front unladen	1	km/h	7
	2	km/h	11,2
	3	km/h	23,9
	4	km/h	42,5
- Rear unladen	1	km/h	7
	2	km/h	11,2
	3	km/h	23,9
	4	km/h	42,5
Standard attachment			PFB 35 MT 1260
- Weight of attachment (without forks)		kg	95
- Weight of forks (each)		kg	72,5
Rated capacity with standard attachment		kg	3000
Tipping load at maximum reach on tires		kg	1300
Distance from the center of gravity of the load to the base of the forks		mm	500
Standard lifting height		mm	6100
Lift truck weight without attachment		kg	6770
Weight of lift truck with standard attachment			
- Unladen		kg	7010
- At rated load		kg	10010
Weight per axle with standard attachment (transport position)			
- Front unladen		kg	3330
- Rear unladen		kg	3680
- Front rated load		kg	8490
- Rear rated load		kg	1520
Weight per axle with standard attachment (boom extended)			
- Front rated load		kg	7410
- Rear rated load		kg	850
Tractive effort on the coupling hook			
- Unladen (sliding)		daN	4700
- At rated load (transmission setting)		daN	6300
Break-out force with bucket (according to standard ISO 8313)		daN	4517

TIRES

		PRESSURE (bar)	LOAD PER TIRE (kg)			
			FRONT UNLADEN	FRONT (LADEN)	REAR (UNLADEN)	REAR (LADEN)
ALLIANCE	405/70R24 580 150A8	3,5	1700	4300	1800	700
	460/70R24 580 159A8	3,5				
	400/70R20 580 149A8	3,5				
MICHELIN	400/70 R20 XMCL 149A8	3,5				
	400/70 R20 149A8/149B IND TL BIBLOAD HARD SURFACE	3,5				
	460/70 R24 159A8/159B IND TL XMCL	3,5				
	460/70 R24 159A8/159B IND TL BIBLOAD HARD SURFACE	3,5				
NOKIAN	460/65R24 156A8/151D TRI STEEL TL	3,5				
TRELLEBORG	460/70R24 TL 159A8 TH400	3,5				
VREDESTEIN	460/70R24 ENDURION	3,2				

		MLT630 PNEUMATIQUES - TYRES	
		Bar	PSI
A	405/70R24 150A8 ALLIANCE	3.5	51
	460/70R24 ENDURION VREDESTEIN	3.2	47
	460/70R24 TH400 159A8 TRELLEBORG	3.5	51
	460/70R24 BIBLOAD 159A8 MICHELIN	3.5	51
	460/65R24 TRI STEEL NOKIAN	3.5	51
	460/70R24 A580 159A8 ALLIANCE	3.5	51
	460/70R24 XMCL 159A8 MICHELIN	3.5	51
B	400/70R20 XMCL 149A8 MICHELIN	3.5	51
	400/70R20 BIBLOAD 149A8 MICHELIN	3.5	51
	400/70R20 149A8 ALLIANCE	3.5	51
	500/70R20 A331 160A8 ALLIANCE	3.5	51
n°52696521			

		PRESSURE (bar)	LOAD (kg)	GROUND CONTACT PRESSURE (kg/cm ²)		GROUND CONTACT AREA (cm ²)	
				HARD GROUND	SOFT GROUND	HARD GROUND	SOFT GROUND
ALLIANCE	405/70R24 580 150A8	3,5	700	4,86	1,58	144	443
			1700	6,30	1,89	270	899
			1800	6,36	1,89	283	952
			4300	8,13	2,86	529	1502
	460/70R24 580 159A8	3,5	700	4,27	1,59	164	439
			1700	5,55	2,07	306	820
			1800	5,71	2,09	315	860
			4300	7,38	2,68	583	1607
	400/70R20 580 149A8	3,5	700	4,70	1,56	149	448
			1700	5,81	1,83	293	929
			1800	5,88	1,91	306	940
			4300	8,01	2,76	537	1556
MICHELIN	400/70 R20 XMCL 149A8	3,5	700				
			1700				
			1800				
			4300				
	400/70 R20 149A8/149B IND TL BIBLOAD HARD SURFACE	3,5	700				
			1700				
			1800				
			4300				
	460/70 R24 159A8/159B IND TL XMCL	3,5	700	1,48	0,48	494	1531
			1700	2,01	0,89	843	1903
			1800	2,06	0,92	873	1940
			4300	2,82	1,48	1507	2869
	460/70 R24 159A8/159B IND TL BIBLOAD HARD SURFACE	3,5	700	2,93	0,96	240	734
			1700	4,52	1,56	376	1087
			1800	4,65	1,62	387	1114
			4300	7,12	2,62	599	1629
NOKIAN	460/65R24 156A8/151D TRI STEEL TL	3,5	700				
			1700				
			1800				
			4300				
TRELLEBORG	460/70R24 TL 159A8 TH400	3,5	700	5,30	1,50	133	469
			1700	6,89	1,90	247	894
			1800	6,95	1,91	259	944
			4300	8,54	2,71	500	1572
VREDESTEIN	460/70R24 ENDURION	3,2	700				
			1700				
			1800				
			4300				

DIMENSIONS

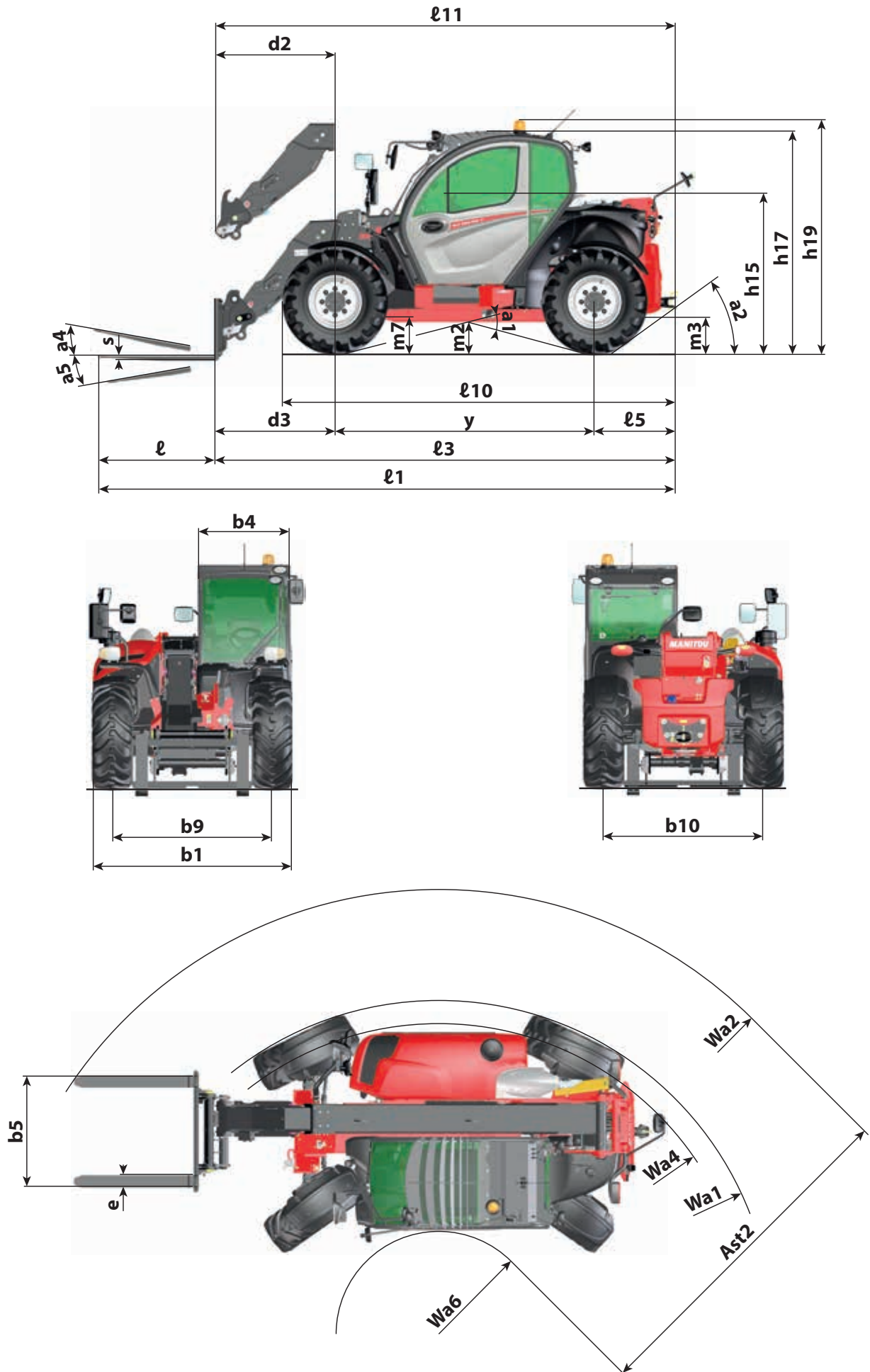

MACHINE LENGTH	ℓ1	mm	5984
	ℓ3	mm	4784
	ℓ5	mm	843
	ℓ10	mm	4121
	ℓ11	mm	4736
MACHINE WIDTH	b1	mm	2132
	b4	mm	950
	b5	mm	1260
	b9	mm	1730
	b10	mm	1730
MACHINE HEIGHT	h15	mm	1726
	h17	mm	2368
	h19	mm	2480
DISTANCE	d2	mm	1203
	d3	mm	1251
AISLE WIDTH	Ast2	mm	3615
ATTACHMENT	ℓ	mm	1200
	e	mm	125
	s	mm	45
TURNING RADIUS	Wa1	mm	3681
	Wa2	mm	4955
	Wa4	mm	3480
	Wa6	mm	1340
GROUND CLEARANCE	m2	mm	347
	m3	mm	457
	m7	mm	457
ANGLE	a1	°	37
	a2	°	42
	a4	°	13
	a5	°	133
WHEELBASE	y	mm	2690

LOAD CHARTS

STANDARD WITH TIRES "A"

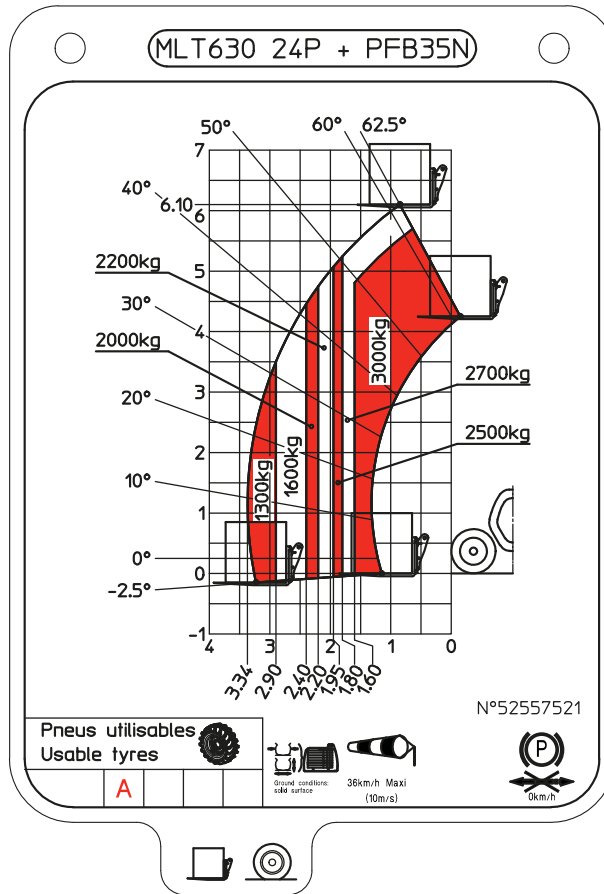

STANDARD WITH TIRES "B"

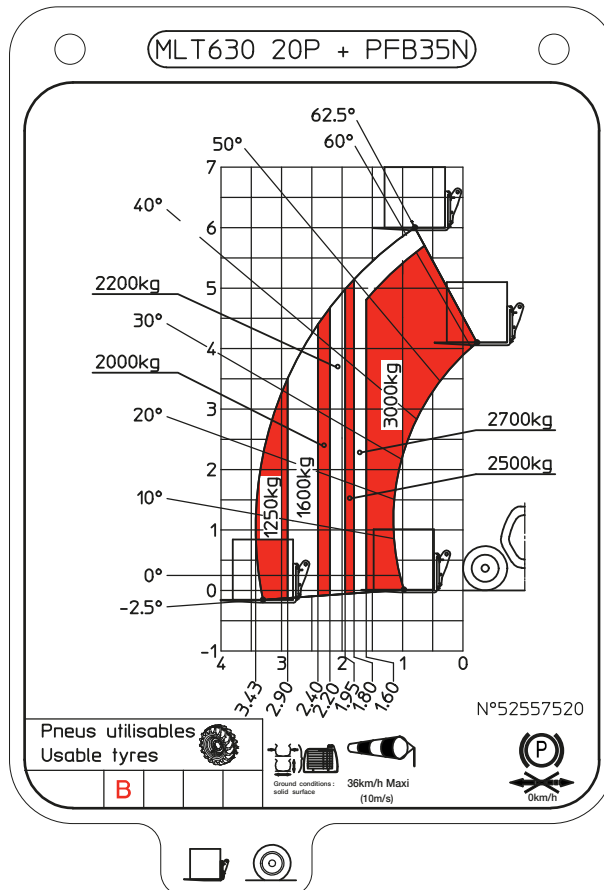

VISIBILITY

We use European standard EN15830 relating to operator visibility.

- Adhere to the instructions for optimizing operator visibility in the immediate vicinity (☞ 1 - OPERATING AND SAFETY INSTRUCTIONS: OPERATOR INSTRUCTIONS: OPERATING INSTRUCTIONS WITH AND WITHOUT LOAD: D - VISIBILITY).

DESCRIPTION AND ADJUSTMENT OF REAR-VIEW MIRRORS

- 1 - LEFT REAR-VIEW MIRROR
- 2 - MAIN RIGHT REAR-VIEW MIRROR
- 3 - SECONDARY RIGHT REAR-VIEW MIRROR
- 4 - RIGHT REAR-VIEW MIRROR
- 5 - INTERNAL REAR-VIEW MIRROR
- 6 - REAR-VIEW MIRROR

- Place the lift truck on level ground with the engine stopped, and the boom retracted and lowered as far as possible.
- Note the position of the reference points ●...○ in the illustrations, to see and correctly adjust the rear-view mirrors.

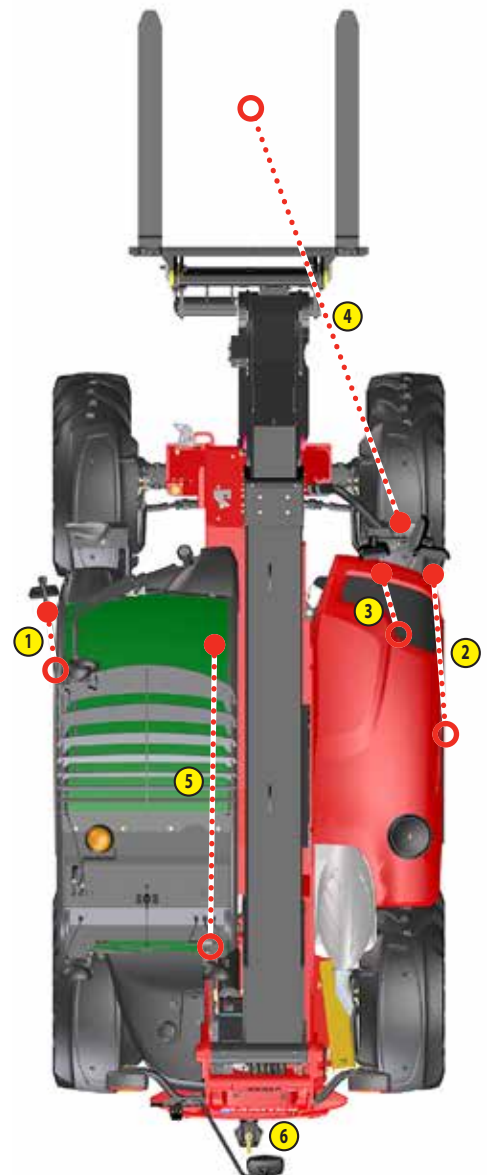
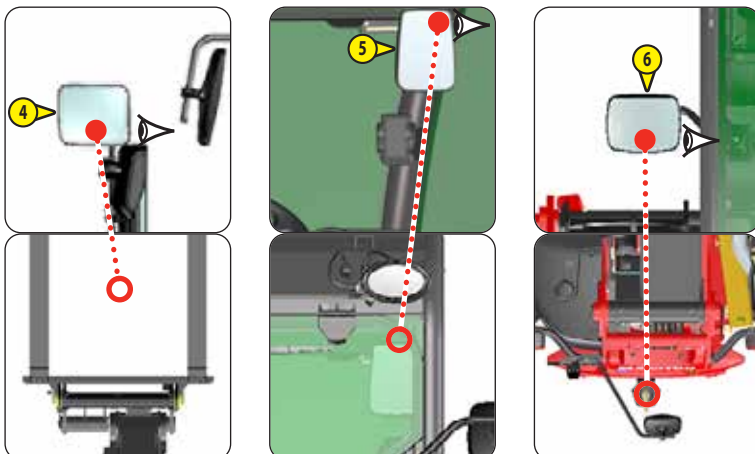
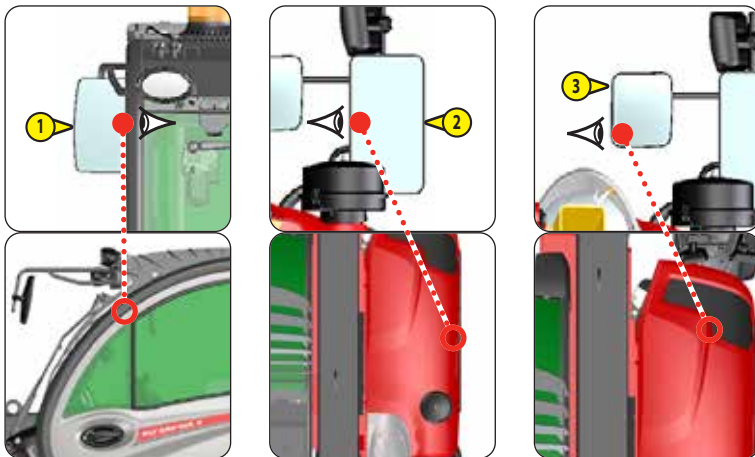
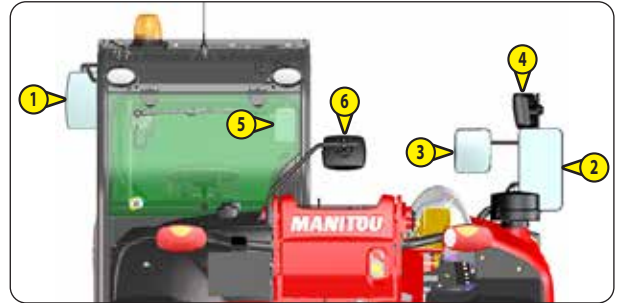

DIRECT AND/OR INDIRECT VISIBILITY BLIND SPOT ZONES

The two diagrams below indicate blind spot zones on the visibility test circle (12 m radius) and the 1 m rectangular zone around the lift truck, according to tests carried out in accordance with EN 15830.

We draw the attention of the operator to the masking within zone B of the visibility test circle, which could conceal an obstacle or a pedestrian. The operator must maneuver the lift truck with utmost care when turning to the left.

HANDLING SUSPENDED LOADS (Test carried out in accordance with 6.3.3 of EN 15830)

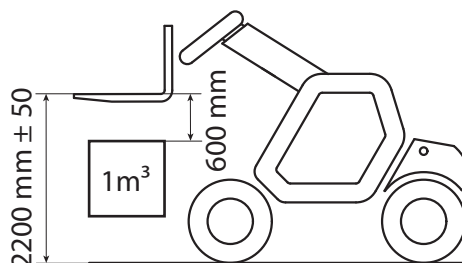

LOADING THE TRAILER (Test carried out in accordance with 6.3.4 of EN 15830)

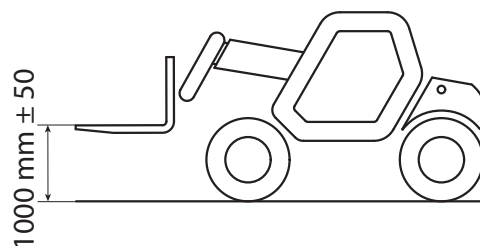

INSTRUMENTS AND CONTROLS

DESCRIPTION

N.B.: All the terms such as: RIGHT, LEFT, FRONT, REAR are as seen by an observer occupying the driver's seat and looking straight ahead.

1 - DRIVER'S CAB ACCESS	2-36
2 - STEP LIGHTING	2-36
3 - DRIVER'S SEAT	2-36
4 - ARMREST AND STORAGE	2-39
5 - SEAT BELT	2-39
6 - BATTERY CUT-OFF	2-39
7 - EMERGENCY STOP	2-39
8 - IGNITION SWITCH	2-39
9 - DASHBOARD "HARMONY"	2-40
10 - DASHBOARD "VISION"	2-44
11 - LONGITUDINAL STABILITY LIMITER AND WARNING DEVICE	2-48
12 - INFORMATION SCREEN CONTROL CONSOLE	2-50
13 - PUSH BUTTON PANEL	2-51
14 - SWITCHES	2-53
15 - 12V SOCKET	2-53
16 - DIAGNOSTIC PLUG	2-53
17 - USB RECHARGING SOCKET	2-53
18 - LIGHTING, HORN AND INDICATOR SWITCH	2-54
19 - FRONT AND REAR WIPER SWITCH	2-54
20 - FUSES AND RELAYS IN THE CAB	2-55
21 - FUSES AND RELAYS UNDER THE ENGINE HOOD	2-57
22 - FORWARD/NEUTRAL/REVERSE SELECTOR	2-58
23 - GEAR LEVER AND TRANSMISSION CUT-OFF	2-58
24 - STEERING SELECTION	2-59
25 - PARKING BRAKE LEVER	2-59
26 - ACCELERATOR PEDAL	2-59
27 - SERVICE BRAKE PEDAL AND TRANSMISSION CUT-OFF	2-59
28 - FUNCTION FILES	2-60
29 - HYDRAULIC BOOM CONTROLS	2-60
30 - LEVEL INDICATOR	2-60
31 - HEATER CONTROL	2-61
32 - AIR CONDITIONING CONTROLS (AIR CONDITIONING OPTION)	2-61
33 - HEATING VENTS	2-61
34 - WINDSHIELD DEFROSTER VENTS	2-61
35 - WINDOW WINDER	2-62
36 - DOOR OPENING AND CLOSING HANDLE	2-62
37 - REAR WINDOW STAY	2-62
38 - STORAGE NET	2-62
39 - STORAGE	2-62
40 - CUP HOLDER	2-62
41 - FRONT HEADLIGHTS	2-62
42 - REAR LIGHTS	2-63
43 - ROTATING BEACON LIGHT	2-63
44 - SUN VISOR	2-63
45 - ROOF LIGHT	2-63
46 - COAT HOOK	2-63
47 - INTERNAL REAR-VIEW MIRROR	2-63
48 - TELEPHONE HOLDER	2-63
49 - STEERING WHEEL ADJUSTMENT LEVER	2-63
50 - EMERGENCY HAMMER	2-64
51 - BOOM SAFETY WEDGE	2-64
52 - FUEL TANK	2-64
53 - TANK "DEF" (Diesel Exhaust Fluid)	2-65

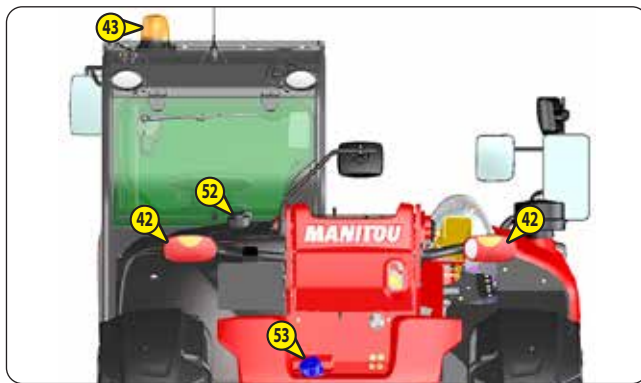
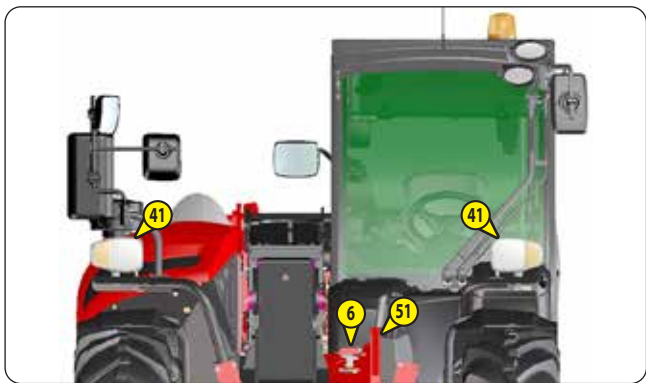

EMERGENCY BRAKE

SERVICE BRAKE

If the service brake is not working properly:

- Press down fully on the service brake pedal to immobilize the machine.
- Activate the hand-operated parking brake.



HAND-OPERATED PARKING BRAKE

⚠ IMPORTANT ⚠

Beware of sudden immobilization of the machine

In the event of immediate danger:

- Activate the hand-operated parking brake.



EMERGENCY EXIT

REAR WINDOW

Use the rear window as an emergency exit, in the event that it is impossible to leave the cab by the door or by opening the windshield.

- Remove the pin to fully open the rear window.



EMERGENCY HAMMER

Use the emergency hammer to break one of the windows in the event that it is impossible to exit the cab by the door or by opening the rear window.



1 - DRIVER'S CAB ACCESS

- Face the driver's cab access to get in and out, and always use the three support points provided for this purpose.
 - 1 - Left handle.
 - 2 - Right handle.
 - 3 - Step.



2 - STEP LIGHTING



3 - DRIVER'S SEAT

For increased comfort, adjust the seat to your requirements and adopt the correct position in the driver's cab.

⚠ IMPORTANT ⚠

Under no circumstances must the seat be adjusted while the lift truck is moving.

MAINTENANCE

⚠ IMPORTANT ⚠

A moving backrest increases the risk of an accident!

Dirt may adversely affect the correct functioning of the seat. For this reason, make sure your seat is always clean.

- To clean or change the cushions, simply remove them from the seat frame.
- Avoid wetting the cushion fabric when cleaning it. First check the resistance of the fabric on a small concealed area before using any fabric and plastic cleaner.

DRIVER'S SEAT "CLASSIC"

DESIGNED FOR MAXIMUM COMFORT, THIS SEAT CAN BE ADJUSTED AS FOLLOWS.

WEIGHT ADJUSTMENT

It is recommended to adjust the weight when the driver is not in the seat.

- Refer to graduation 1 of the seat.
- Turn handle 2 according to the driver's weight.

N.B.: To avoid health problems, it is recommended that the weight setting is checked and adjusted before starting the lift truck.

HEADREST

- The height of the headrest 3 can be adjusted by pulling it upward (the notches will click) up to the stop.
- The headrest can be removed by applying sufficient pressure to pull it off the stop.

BACKREST ANGLE ADJUSTMENT

⚠ IMPORTANT ⚠

If you do not support the backrest when making adjustments, it swings completely forward.

- Support the backrest, pull the lever 4 and tilt the backrest to the desired position.

LONGITUDINAL ADJUSTMENT

- Engage the locking lever 5 in the desired position. Once locked, you can no longer move the seat into another position.



PNEUMATIC DRIVER'S SEAT "PREMIUM"

DESIGNED FOR MAXIMUM COMFORT, THIS SEAT CAN BE ADJUSTED AS FOLLOWS.

WEIGHT AND SEAT HEIGHT ADJUSTMENT

WEIGHT ADJUSTMENT

Adjust the seat according to your weight while correctly seated.

- Switch on lift truck ignition.
- Push or pull lever 1 until green appears in display 2 indicating correct adjustment according to your weight.

N.B.: To avoid health problems, it is recommended that the weight setting is checked and adjusted before starting the lift truck.

SEAT HEIGHT ADJUSTMENT

⚠ IMPORTANT ⚠

To avoid damage, do not operate the compressor for more than 1 minute.

When weight adjustment has been carried out, you can then modify seat height.

- Keep the ignition on in the lift truck.
- Push or pull lever 1 until green appears and adjust the height of the seat while checking that the green in display 2 remains visible.

HEADREST

- The height of the headrest 3 can be adjusted by pulling it upward (the notches will click) up to the stop.
- The headrest can be removed by applying sufficient pressure to pull it off the stop.

BACKREST ANGLE ADJUSTMENT

⚠ IMPORTANT ⚠

If you do not support the backrest when making adjustments, it swings completely forward.

- Support the backrest, pull the lever 4 and tilt the backrest to the desired position.

LONGITUDINAL ADJUSTMENT

- Engage the locking lever 5 in the desired position. Once locked, you can no longer move the seat into another position.



PNEUMATIC DRIVER'S SEAT "ÉLITE"

DESIGNED FOR MAXIMUM COMFORT, THIS SEAT CAN BE ADJUSTED AS FOLLOWS.

WEIGHT AND SEAT HEIGHT ADJUSTMENT

⚠ IMPORTANT ⚠

To avoid damage, do not operate the compressor for more than 1 minute.

WEIGHT ADJUSTMENT

Adjust the seat according to your weight while correctly seated.

- Switch on lift truck ignition.
- Briefly pull up lever 1 to automatically adjust the seat according to your weight.

N.B.: To avoid health problems, it is recommended that the weight setting is checked and adjusted before starting the lift truck.

SEAT HEIGHT ADJUSTMENT

- Fully push in or pull out lever 1 to adjust the height of the seat. When the upper or lower end stop is reached, the seat automatically adjusts itself, thus minimizing the damping stroke.

HORIZONTAL SHOCK ABSORBER

In certain conditions (e.g. driving with a trailer) it is advised the horizontal shock absorber 2 be used. The driver's seat is thus better able to absorb jerks in the direction of travel.

- Position A: Horizontal shock absorber removed.
- Position B: Horizontal shock absorber fitted.

HEADREST

- The height of the headrest 3 can be adjusted by pulling it upward (the notches will click) up to the stop.
- The headrest can be removed by applying sufficient pressure to pull it off the stop.



BACKREST ANGLE ADJUSTMENT

⚠ IMPORTANT ⚠

If you do not support the backrest when making adjustments, it swings completely forward.

- Support the backrest, pull the lever 4 and tilt the backrest to the desired position.

LONGITUDINAL ADJUSTMENT

- Engage the locking lever 5 in the desired position. Once locked, you can no longer move the seat into another position.

LUMBAR ADJUSTMENT

This increases the comfort of the seat and the driver's freedom of movement.

- Turn the handle 6 either left or right to adjust the height or depth of the lumbar support.

HEATED PNEUMATIC DRIVER'S SEAT "LUXE"

DESIGNED FOR MAXIMUM COMFORT, THIS SEAT CAN BE ADJUSTED AS FOLLOWS.

WEIGHT AND SEAT HEIGHT ADJUSTMENT

⚠ IMPORTANT ⚠

To avoid damage, do not operate the compressor for more than 1 minute.

WEIGHT ADJUSTMENT

Adjust the seat according to your weight while correctly seated.

- Switch on lift truck ignition.
- Briefly pull up lever 1 to automatically adjust the seat according to your weight.

N.B.: To avoid health problems, it is recommended that the weight setting is checked and adjusted before starting the lift truck.

SEAT HEIGHT ADJUSTMENT

- Fully push in or pull out lever 1 to adjust the height of the seat. When the upper or lower end stop is reached, the seat automatically adjusts itself, thus minimizing the damping stroke.

HORIZONTAL SHOCK ABSORBER

In certain conditions (e.g. driving with a trailer) it is advised the horizontal shock absorber 2 be used. The driver's seat is thus better able to absorb jerks in the direction of travel.

- Position A: Horizontal shock absorber removed.
- Position B: Horizontal shock absorber fitted.

HEADREST

- The height of the headrest 3 can be adjusted by pulling it upward (the notches will click) up to the stop.
- The headrest can be removed by applying sufficient pressure to pull it off the stop.

BACKREST ANGLE ADJUSTMENT

⚠ IMPORTANT ⚠

If you do not support the backrest when making adjustments, it swings completely forward.

- Support the backrest, pull the lever 4 and tilt the backrest to the desired position.

LONGITUDINAL ADJUSTMENT

- Engage the locking lever 5 in the desired position. Once locked, you can no longer move the seat into another position.

LUMBAR ADJUSTMENT

This increases the comfort of the seat and the driver's freedom of movement.

- The lumbar support in the upper or lower part of the backrest can be separately adjusted by operating the upper or lower switch.
- The curvature of the lumbar adjustment setting is adjusted by pressing "+" or "-" on the corresponding switch 6.
- Release the switch when the desired backrest curvature is achieved.

HEATING

- Operate switch 7 to enable or disable the seat heating function.



4 - ARMREST AND STORAGE

Lift the armrest to access the storage.

⚠ IMPORTANT ⚠

Make sure that the armrest's position is as ergonomic as possible to improve comfortable operation or handling hydraulics.



5 - SEAT BELT

⚠ IMPORTANT ⚠

*Under no circumstances must the lift truck be used if the seat belt is defective (fixing, locking, cuts, tears, etc.).
Immediately repair or replace the seat belt.*

- Sit correctly on the seat.
- Check that the seat belt is not twisted.
- Place the seat belt at hip level.
- Attach the seat belt and check that it locks.
- Adjust the seat belt to your body shape without compressing your pelvis and without excessive slack.



6 - BATTERY CUT-OFF

Enables the battery to be quickly cut off when stopping use of the lift truck, as a preventive measure after parking, if work is being done on the electrical system or in an emergency to isolate a short-circuit.

⚠ IMPORTANT ⚠

Except in an emergency (fire, accident, overturning of the lift truck), never operate the battery cut-off with the engine running as this could damage the alternator and the lift truck's electronic components.

- Switch off the ignition with the key, wait 30 seconds, then operate the battery cut-off.
- N.B.: Wait 5 minutes before disconnecting the battery, this is required in order to purge the Diesel Exhaust Fluid (DEF) system.



7 - EMERGENCY STOP

In the event of danger, it enables the engine to be shut down, thereby cutting-off all hydraulic movements.

⚠ IMPORTANT ⚠

*Be ready for hydraulic movements suddenly stopping when you press this button.
If possible stop the lift truck before using the emergency stop button.*

- Turn switch to disable.



8 - IGNITION SWITCH

This key switch has 5 positions:

- P - Not used.
- O - Ignition cut-off and engine stop.
- I - Ignition + preheat.
- II - Not used.
- III - Start-up and return to I position as soon as the key is released.



9 - DASHBOARD "HARMONY"

INSTRUMENTS AND INDICATORS

A - TACHOMETER

B - ENGINE WATER TEMPERATURE

If the indicator lamp  comes on when the lift truck is running, this means that the coolant temperature is high. Leave the engine idling to lower the water temperature. If the fault persists, turn the engine off and investigate the cooling circuit for the cause of the malfunction.

C - FUEL LEVEL

Indicator lamp , indicates that you are in reserve and that your running time is limited.

D - LEVEL "DEF" (Diesel Exhaust Fluid)

The indicator lamp  comes on if the level is below 15%.

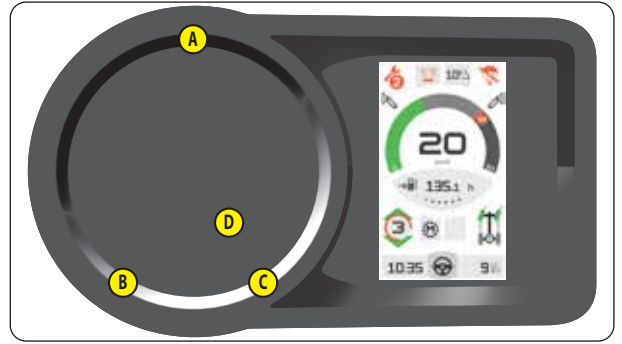

BATTERY LOAD FAULT INDICATOR

If the indicator and the buzzer come on when the lift truck is running, stop the engine immediately and determine the cause (electric circuit, alternator belt, alternator, etc.).

STEERING SYSTEM OIL PRESSURE FAULT INDICATOR

If the indicator comes on when the lift truck is running, stop the engine immediately and determine the cause (possible leak, etc.).

WATER IN FUEL PRE-FILTER FAULT INDICATOR

The indicator light will come on when water is detected in the fuel pre-filter. Stop the lift truck and carry out the necessary repairs.

BRAKE FLUID PRESSURE FAULT INDICATOR

If the lamp and the buzzer come on when the lift truck is running, stop the engine immediately and consult your dealer.

ENGINE OIL PRESSURE FAULT INDICATOR

If the indicator light comes on when the lift truck is in operation, stop the engine immediately and look for the cause (oil level in engine crankcase).

N.B.: After starting the engine, the indicator lamp remains on for a few seconds then goes out when the correct engine oil pressure is reached. The full engine power is then available.

ENGINE PREHEATING INDICATOR

Preheating is necessary. When the lift truck is switched on, the indicator lamp comes on for 2 seconds and goes off as soon as preheat is ended. Start the lift truck's engine.



GEARBOX OIL PRESSURE FAULT INDICATOR

The indicator lamp and buzzer come on when there is an abnormal drop in gearbox pressure, in forward gear. Stop the engine and determine the cause (gearbox oil level, possible leak, radiator, etc.).

N.B.: This indicator lamp operates in forward travel conditions only, and can be ignored when the lift truck is stopped with the engine running at min rpm.



GEARBOX OIL TEMPERATURE FAULT INDICATOR

The indicator and buzzer come on when the gearbox oil temperature is abnormally high. Stop the engine and determine the cause (gearbox oil level, possible leak, radiator, etc.).



HYDRAULIC RETURN FILTER CLOGGING FAULT INDICATOR

The indicator light and buzzer come on when the hydraulic return oil filter cartridge is clogged. Stop the engine and carry out the necessary repairs (≤ 3 - MAINTENANCE: FILTER CARTRIDGES AND BELTS).



ENGINE COOLANT LEVEL FAULT INDICATOR

If the indicator light and buzzer come on when the lift truck is in operation, stop the engine immediately and determine the cause (coolant level, possible leak, radiator, etc.).



ENGINE STOPPED FAULT INDICATOR

If the indicator lights up or flashes when the lift truck is in operation, stop the engine immediately and consult your dealer.



AIR FILTER CLOGGING FAULT INDICATOR

The light and the buzzer come on when the air filter cartridge is clogged. Stop the engine and carry out the necessary repairs (≤ 3 - MAINTENANCE: FILTER CARTRIDGES AND BELTS).







ENGINE FAULT INDICATOR

If the indicator light comes on or flashes while the lift truck is in operation, a diagnostic fault has been detected. The lift truck will operate in reduced mode. Consult your dealer as soon as possible.



FAULT INDICATOR "SCR" (selective catalytic reduction)

The indicator comes on if the system is above the efficiency threshold or if a diesel exhaust fluid quality problem is detected.

Flashing  indicator light +  + audible signal	- Level of "DEF" (diesel exhaust fluid) under 10%.
 +  + audible signal	- Consult your dealer as soon as possible.



CRYSTALLIZATION OR SULFURIZATION LEVEL INDICATOR

If the indicator lamp flashes while the lift truck is in operation, perform a "STATIONARY LIFT TRUCK" EXHAUST REGENERATION (≤ 3 - MAINTENANCE: OCCASIONAL MAINTENANCE).

The indicator lamp also comes on when the count (700h = > 0h) before next regeneration has elapsed.

INFORMATION SCREEN

 **HIGH BEAM HEADLIGHTS INDICATOR**

 **LOW BEAM HEADLIGHTS INDICATOR**

 **TURN SIGNAL INDICATOR**

 **PARKING BRAKE LAMP**

 **BEACON INDICATOR**

 **MAINTENANCE REQUIRED**

 **MAINTENANCE OVERDUE**

 **MAINTENANCE OVERDUE + NUMBER OF ERROR CODES**

 **BOOM ANGLE**

 **HYDRAULIC MOVEMENT NEUTRALIZATION**

 **DISABLING "AGGRAVATING" HYDRAULIC MOVEMENT CUT-OFF**

 **NOT USED**

 **GEAR RATIO**

 **MANUAL TRANSMISSION**

 **WHEEL STEERING INDICATOR**

 **CLOCK**

 **DRIVING MODE**

 **WORK MODE**

 **EXTERNAL TEMPERATURE**





HOUR METER

- This screen is displayed for a few seconds when the ignition is switched on.



SPEEDOMETER

- This screen is displayed in driving mode.



HYDRAULIC FLOW RATE ADJUSTMENT

- This screen is displayed in work mode.

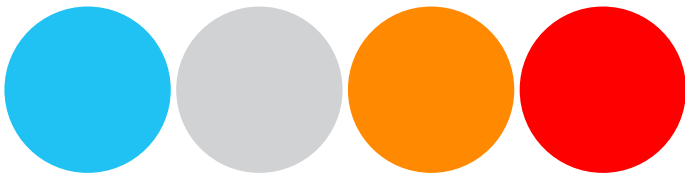

POP UP

- Blue POP UP: information message.
- Grey POP UP: operating message.
- Orange POP UP: warning message.
- Red POP UP: fault message, consult your dealer.



INFORMATION SCREEN

- Hold down and turn the navigation knob A to change the mode.

- Total hour meter.
- Partial hour meter.
- Instantaneous fuel consumption.
- Average fuel consumption.
- Fuel autonomy.
- Tachometer.



10 - DASHBOARD "VISION"

INSTRUMENTS AND INDICATORS

A - TACHOMETER

B - ENGINE WATER TEMPERATURE



If the indicator lamp  comes on when the lift truck is running, this means that the coolant temperature is high. Leave the engine idling to lower the water temperature. If the fault persists, turn the engine off and investigate the cooling circuit for the cause of the malfunction.

C - FUEL LEVEL





Indicator lamp , indicates that you are in reserve and that your running time is limited.

D - LEVEL "DEF" (Diesel Exhaust Fluid)



The indicator lamp  comes on if the level is below 15%.

E - FAULT WARNING LAMP DISPLAY ZONE

A maximum of five indicator lamps are displayed in the display zone. A red arrow  indicates a sixth fault. Beyond six faults, the  arrow flashes.



BATTERY LOAD FAULT INDICATOR

If the indicator and the buzzer come on when the lift truck is running, stop the engine immediately and determine the cause (electric circuit, alternator belt, alternator, etc.).



STEERING SYSTEM OIL PRESSURE FAULT INDICATOR

If the indicator comes on when the lift truck is running, stop the engine immediately and determine the cause (possible leak, etc.).



WATER IN FUEL PRE-FILTER FAULT INDICATOR

The indicator light will come on when water is detected in the fuel pre-filter. Stop the lift truck and carry out the necessary repairs.



BRAKE FLUID PRESSURE FAULT INDICATOR

If the lamp and the buzzer come on when the lift truck is running, stop the engine immediately and consult your dealer.



ENGINE OIL PRESSURE FAULT INDICATOR

If the indicator light comes on when the lift truck is in operation, stop the engine immediately and look for the cause (oil level in engine crankcase).

N.B.: After starting the engine, the indicator lamp remains on for a few seconds then goes out when the correct engine oil pressure is reached. The full engine power is then available.



ENGINE PREHEATING INDICATOR

Preheating is necessary. When the lift truck is switched on, the indicator lamp comes on for 2 seconds and goes off as soon as preheat is ended. Start the lift truck's engine.





GEARBOX OIL PRESSURE FAULT INDICATOR

The indicator lamp and buzzer come on when there is an abnormal drop in gearbox pressure, in forward gear. Stop the engine and determine the cause (gearbox oil level, possible leak, radiator, etc.).

N.B.: This indicator lamp operates in forward travel conditions only, and can be ignored when the lift truck is stopped with the engine running at min rpm.



GEARBOX OIL TEMPERATURE FAULT INDICATOR

The indicator and buzzer come on when the gearbox oil temperature is abnormally high. Stop the engine and determine the cause (gearbox oil level, possible leak, radiator, etc.).



HYDRAULIC RETURN FILTER CLOGGING FAULT INDICATOR

The indicator light and buzzer come on when the hydraulic return oil filter cartridge is clogged. Stop the engine and carry out the necessary repairs (≤ 3 - MAINTENANCE: FILTER CARTRIDGES AND BELTS).



ENGINE COOLANT LEVEL FAULT INDICATOR

If the indicator light and buzzer come on when the lift truck is in operation, stop the engine immediately and determine the cause (coolant level, possible leak, radiator, etc.).



ENGINE STOPPED FAULT INDICATOR

If the indicator lights up or flashes when the lift truck is in operation, stop the engine immediately and consult your dealer.



AIR FILTER CLOGGING FAULT INDICATOR

The light and the buzzer come on when the air filter cartridge is clogged. Stop the engine and carry out the necessary repairs (≤ 3 - MAINTENANCE: FILTER CARTRIDGES AND BELTS).







ENGINE FAULT INDICATOR

If the indicator light comes on or flashes while the lift truck is in operation, a diagnostic fault has been detected. The lift truck will operate in reduced mode. Consult your dealer as soon as possible.



FAULT INDICATOR "SCR" (selective catalytic reduction)

The indicator comes on if the system is above the efficiency threshold or if a diesel exhaust fluid quality problem is detected.

Flashing  indicator light +  + audible signal	- Level of "DEF" (diesel exhaust fluid) under 10%.
 +  + audible signal	- Consult your dealer as soon as possible.



CRYSTALLIZATION OR SULFURIZATION LEVEL INDICATOR

If the indicator lamp flashes while the lift truck is in operation, perform a "STATIONARY LIFT TRUCK" EXHAUST REGENERATION (≤ 3 - MAINTENANCE: OCCASIONAL MAINTENANCE).

The indicator lamp also comes on when the count (700h = > 0h) before next regeneration has elapsed.

INFORMATION SCREEN



HIGH BEAM HEADLIGHTS INDICATOR



LOW BEAM HEADLIGHTS INDICATOR

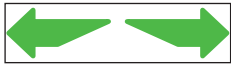

TURN SIGNAL INDICATOR



PARKING BRAKE LAMP



BEACON INDICATOR



59° BOOM ANGLE



MAINTENANCE REQUIRED



MAINTENANCE OVERDUE



MAINTENANCE OVERDUE + NUMBER OF ERROR CODES



HYDRAULIC MOVEMENT NEUTRALIZATION



DISABLING "AGGRAVATING" HYDRAULIC MOVEMENT CUT-OFF



GEAR RATIO



MANUAL TRANSMISSION



WHEEL STEERING INDICATOR



10:35 CLOCK



DRIVING MODE



WORK MODE



CAMERA (OPTION)



22 °C EXTERNAL TEMPERATURE





HOUR METER

- This screen is displayed for a few seconds when the ignition is switched on.



SPEEDOMETER

- This screen is displayed in driving mode.



HYDRAULIC FLOW RATE ADJUSTMENT

- This screen is displayed in work mode.

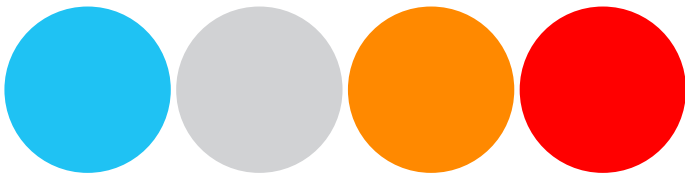

POP UP

- Blue POP UP: information message.
- Grey POP UP: operating message.
- Orange POP UP: warning message.
- Red POP UP: fault message, consult your dealer.



INFORMATION SCREEN

- Hold down and turn the navigation knob A to change the mode.

- Total hour meter.
- Partial hour meter.
- Instantaneous fuel consumption.
- Average fuel consumption.
- Fuel autonomy.
- Tachometer.



11 - LONGITUDINAL STABILITY LIMITER AND WARNING DEVICE

⚠ IMPORTANT ⚠

The operator must respect the lift truck's load chart, and the operating mode according to the attachment.

This device warns the operator of the forklift truck's longitudinal stability limits. However, lateral stability can reduce the load chart in the upper part, and this reduction is not detected by the device.

Depending on the type of work required, the operating modes of the longitudinal stability limiter and warning device allow the operator to operate the lift truck in complete safety.

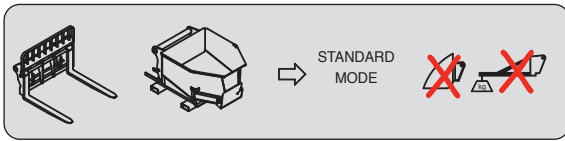
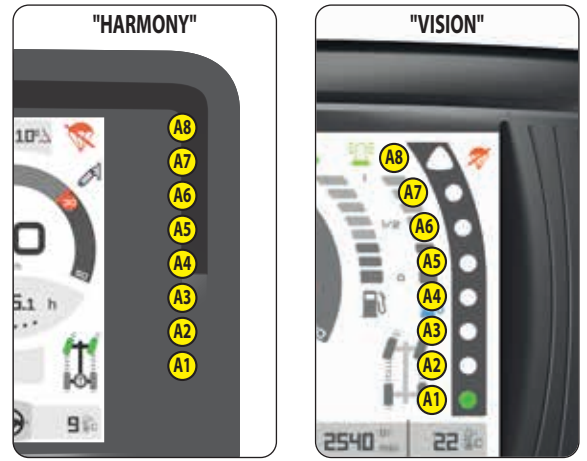

"HANDLING" MODE

USE ON FORKS

- By default, the device is in "HANDLING MODE" each time the lift truck is started.
- Protection against tilting forward during aggravating movements is guaranteed, except when the telescope is retracted.

STATUS OF THE DEVICE			
HALTED	SLOW SPEED 1 to 5 km/h	SPEED > 5 km/h	TELESCOPE(S) RETRACTED
A4-A5 : Very slow intermittent sound alarm. A6 : Slow intermittent sound alarm. A7 : Fast intermittent audible alarm. A8 : Very fast intermittent audible alarm.	A7 : Fast intermittent audible alarm. A8 : Very fast intermittent audible alarm.	-No sound alarm.	-No sound alarm. -Indicator light on.

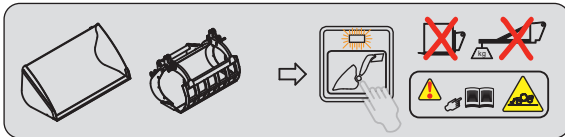

"BUCKET" MODE

USE WITH BUCKET

- Place the lift truck in the transport position.
- Press the button, "BUCKET" MODE is confirmed by an audible signal and by the light coming on.
- Press this button again or switch off the ignition with the ignition key to return to "HANDLING" MODE.
- Protection against tilting forward during aggravating movements is guaranteed, except when the telescope is retracted.

STATUS OF THE DEVICE			
HALTED	SLOW SPEED 1 to 5 km/h	SPEED > 5 km/h	TELESCOPE(S) RETRACTED
-The "BUCKET" mode deactivates after a few seconds if the lift truck remains stationary.	A6 : An audible signal upon passing into the red zone. -The hydraulic movements are adapted.	No sound alarm. -The hydraulic movements are adapted.	-No sound alarm. -Indicator light on.

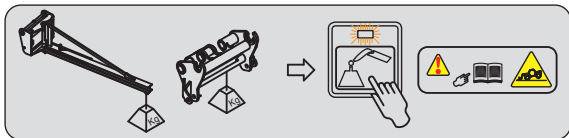

"SUSPENDED LOAD" MODE

USE WITH LIFTING DEVICE (offering a higher margin of safety)

- Place the lift truck in the transport position.
- Press the  button; the "SUSPENDED LOAD" MODE is confirmed by an audible signal and by the indicator lamp coming on. Hydraulic tilting movements are neutralized, as well as the lifting movement when the longitudinal stability limit is reached (indicator lamp A8 on).
- Press this button again or switch off the ignition with the ignition key to return to "HANDLING" MODE.
- Protection against tilting forward during aggravating movements is guaranteed, except when the telescope is retracted.

STATUS OF THE DEVICE			
HALTED	SLOW SPEED 1 to 5 km/h	SPEED > 5 km/h	TELESCOPE(S) RETRACTED
	A4-A5 : Very slow intermittent sound alarm. A6 : Slow intermittent sound alarm. A7 : Fast intermittent audible alarm. A8 : Very fast intermittent audible alarm.		-No sound alarm. -Indicator light  on.

A - VISUAL ALARMS

- A1 - A2 - A3: There is a significant reserve of longitudinal stability.
- A4 - A5: The lift truck is nearing the limit of longitudinal stability. Maneuver with care.
- A6: The lift truck is close to the longitudinal stability limit. Maneuver with care.
- A7: The lift truck is very close to the longitudinal stability limit. Manoeuvre with extreme caution.
- A8: The lift truck is at the authorized limit of longitudinal stability.

B - HYDRAULIC MOVEMENT CUT-OFF

"HANDLING" MODE

- A8: All "AGGRAVATING" hydraulic movements are cut off. Only perform de-aggravating hydraulic movements in the following order: retract and raise the boom.

"BUCKET" MODE

- A8: The boom lowering and extension movements are cut off; the other movements remain available.

"SUSPENDED LOAD" MODE



- A8: All "AGGRAVATING" and boom raising hydraulic movements are cut off. Only the boom retraction hydraulic movement is available.

C - DISABLING "AGGRAVATING" HYDRAULIC MOVEMENT CUT-OFF



Remain very vigilant during this operation. The only information available to the operator is the lift truck's dynamic stability.

In certain cases, in order to get out of a difficult situation, the operator can bypass this safety device. The  button temporarily disables the cutting-off of "AGGRAVATING" hydraulic movements.

- Hold down the  button; the indicator lamp will light (60 second time delay), and the  pictogram will appear on the information screen. Simultaneously perform the necessary "AGGRAVATING" hydraulic movement with extreme care.

D - STRAIN GAGE



Disassembly or calibration of the strain gage is prohibited, this must only be done by specially trained personnel, consult your dealer.

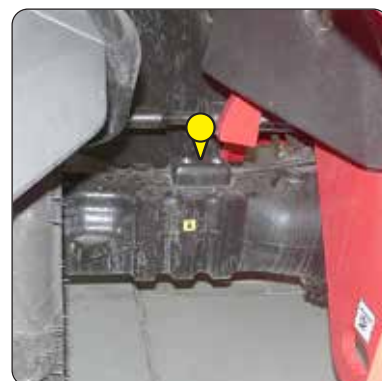

12 - INFORMATION SCREEN CONTROL CONSOLE

N.B.: The content of the "PREFERENCES" and "INFORMATION" menus varies according to the lift truck equipment.

A - NAVIGATION AND VALIDATION BUTTON

B - Preferences MENU

- Press button B to display the "PREFERENCES" menu
- Turn knob A to navigate through the menus and sub-menus.
- Press knob A to confirm.



SYSTEM	>	DATE AND TIME	
	>	LANGUAGES	
	>	UNITS	
	>	SCREEN	
	>	POP UPS	
	>	DIGICODE	
	>	CAMERAS	
	>	CUSTOMER CODE	
	>	CONFIGURATION (customer or expert code)	> PARTIAL HOUR METER RESET
			> MAINTENANCE HOUR METER RESET
TRANSMISSION	>	ECO MODE	
	>	MANUAL ACCELERATOR	
	>	TRAILER BRAKE TEST	
HYDRAULIC	>	STABILITY TEST	
	>	STABILITY REBALANCING	
	>	HYDRAULIC MODES	> STANDARD
			> TRANSPPLUS (Increased flow rate on transmission)
			> HYDROPLUS (Increased flow rate on hydraulics)
	>	EASY CONNECT SYSTEM	
	>	JSM AutoPower	
	>	AXLE BLOCKING TEST	
	>	CONFIGURATION (customer or expert code)	> OVERRIDE
			> MANUAL OVERRIDE NO DRIVER
ENGINE	>	ECO STOP	
	>	FAN DRIVE	
	>	REGENERATION	
EXPERT (expert code)	>	STABILITY CALIBRATION	
	>	BOOM ANGLE CALIBRATION	
	>	INCHING PEDAL CALIBRATION	
	>	CARRIAGE ANGLE CALIBRATION	
	>	DISTRIBUTOR CALIBRATION	
	>	INCLINOMETER CALIBRATION	
	>	EXPERT CODE	

C - INFORMATION MENU

- Press the button to display the "INFORMATION" menu
- Turn knob A to navigate through the menus and sub-menus.
- Press knob A to confirm.

REPAIR	>	FAULTS
MAINTENANCE	>	MAINTENANCE RESET
GENERAL	>	IDENTIFICATION
	>	SOFTWARE VERSION

D - BACK

- Press the button to return to the previous screen.



HYDRAULIC MOVEMENT NEUTRALIZATION

When driving on the road, it is highly recommended (mandatory in Germany) that you disconnect all hydraulic movement. The indicator lamp and  image on the information screen indicate use.



ROTATING BEACON LIGHT

The indicator lamp indicates it is in use.



HAZARD WARNING LIGHTS

13 - PUSH BUTTON PANEL

BUTTON FUNCTIONS

- Red button: Safety.
- Orange button: Transmission / Engine.
- Blue button: Hydraulics.
- Black button: Other.

BUTTON DIAGNOSTICS

- If all buttons are unlit, there is a power supply problem. Contact your dealer.
- If all buttons are flashing, there is a connection problem. Contact your dealer.



DISABLING "AGGRAVATING" HYDRAULIC MOVEMENT CUT-OFF

◀ LONGITUDINAL STABILITY LIMITER AND WARNING DEVICE

NOT USED

TRANSMISSION CUT-OFF

USE OF TRANSMISSION CUT-OFF

- When loading (indicator lamp on):
 - by pressing the gear lever button,
 - or with the service brake pedal during free travel of the pedal,
 - or by placing the forward/neutral/reverse selector in neutral.
- While driving or for slow approaches and gradual restart for delicate handling (indicator lamp off):
 - by pressing the gear lever button,
 - by placing the forward/neutral/reverse selector in neutral.

ENGINE SPEED MEMORIZATION (OPTION)

◀ DESCRIPTION AND USE OF THE OPTIONS

NOT USED

USE OF FRONT OR REAR ATTACHMENT SYSTEM (OPTION)

◀ DESCRIPTION AND USE OF THE OPTIONS

"BUCKET" MODE

◀ LONGITUDINAL STABILITY LIMITER AND WARNING DEVICE

"SUSPENDED LOAD" MODE

◀ LONGITUDINAL STABILITY LIMITER AND WARNING DEVICE

BOOM SUSPENSION (OPTION)

◀ DESCRIPTION AND USE OF THE OPTIONS

FORCED BOOM SUSPENSION (OPTION)

◀ DESCRIPTION AND USE OF THE OPTIONS





ATTACHMENT CIRCUIT FLOW RATE LIMITER (OPTION)

< DESCRIPTION AND USE OF THE OPTIONS



ATTACHMENT CIRCUIT MANUAL OVERRIDE (OPTION)

< DESCRIPTION AND USE OF THE OPTIONS



TILT CIRCUIT LOCKING (OPTION)

- Press the button to shut off the tilt circuit hydraulic movements. The indicator lamp indicates it is in use.



ATTACHMENT CIRCUIT LOCKING (OPTION)

- Press the button to shut off the attachment circuit hydraulic movements. The indicator lamp indicates it is in use.



AUTOMATIC FAN REVERSAL

Cleans the radiator core and the grille of the engine hood by reversing the air flow.

⚠ IMPORTANT ⚠

The ventilation reversal is operational from an engine coolant temperature of 40 °C.

When in use, beware of the risk of projection into the eyes.

- The indicator lamp is on, the fan operates in self-cleaning mode for a few seconds once every 3 minutes.
- The default cycle time is 3 minutes.
- Press button B to display the "PREFERENCES" menu
- Turn knob A to navigate through the menus and sub-menus.



ENGINE	"FAN DRIVE" FAN REVERSAL
--------	--------------------------

- Select the cycle time and press knob A to confirm.



FORCED VENTILATION REVERSAL

- Press the button to force a cleaning cycle. The indicator lamp will light when it is in use.
- Wait for the cycle to finish before forcing another.



SEMI-AUTOMATIC WHEEL ALIGNMENT (OPTION)

< DESCRIPTION AND USE OF THE OPTIONS



EXHAUST REGENERATION

< 3 - MAINTENANCE: OCCASIONAL MAINTENANCE



ECO STOP (OPTION)

< DESCRIPTION AND USE OF THE OPTIONS



NOT USED

14 - SWITCHES



BOOM HEAD WORKLIGHTS (OPTION)



FRONT WORKLIGHTS



REAR WORKLIGHTS



SIDE WORKLIGHTS (OPTION)



REAR FOG LIGHTS



BOOM HEAD ELECTROVALVE (OPTION)



BOOM ELECTRICAL PREDISPOSITION (OPTION)

< DESCRIPTION AND USE OF THE OPTIONS



MAIN RIGHT REAR-VIEW MIRROR DEFROST (OPTION)



BLUE WORKLIGHTS (OPTION)



15 - 12V SOCKET

For 12 V appliance and max. amperage 10A.



16 - DIAGNOSTIC PLUG



17 - USB RECHARGING SOCKET



18 - LIGHTING, HORN AND INDICATOR SWITCH

The switch controls the visual and sound alarms.

- A - All lights are off, the turn signals do not flash.
- B - The right-hand turn signals flash.
- C - The left-hand turn signals flash.
- D - The sidelights and rear lights are on.
- E - The dipped beam headlights and rear lights are on.
- F - The main beam headlights and rear lights are on.
- G - Headlight signaling.

Pressing the end of the switch sounds the horn.

N.B.: Positions D - E - F - G can be used without switching on the ignition.

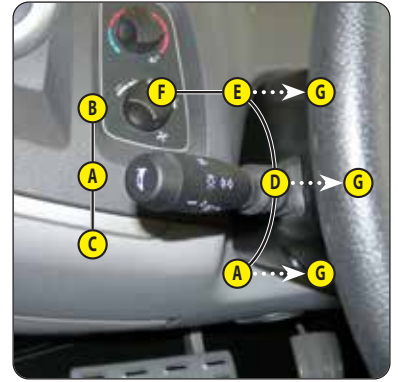

19 - FRONT AND REAR WIPER SWITCH

FRONT WINDSHIELD WIPER

- A - Front windshield wiper off.
- B - Front windshield wiper low speed setting.
- C - Front windshield wiper low speed setting.
- D - Front windshield wiper intermittent operation.
- E - Front windshield wiper pulse driven.

REAR WINDSHIELD WIPER

- F - Rear windshield wiper off.
- G - Rear windshield wiper on.
- H - Rear windshield washer, pulse driven (not used).

N.B.: These functions will only work when the ignition is switched on.

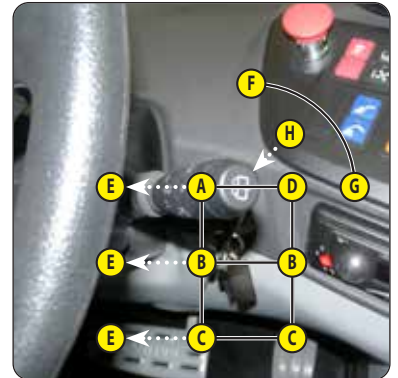

20 - FUSES AND RELAYS IN THE CAB

A sticker on the inside of the access hatch provides a quick view of the use of the electric plate's components described below.

- Remove access panel 1 to gain access to the fuses and relays. Replace a blown fuse with a new fuse of the same quality and rating. Never use a repaired fuse.



MINIFUSE

F1	20A	Front windshield wiper. Front windshield washer. Relay (K1 K2).
F2	5A	JSM joystick.
F3	5A	Screen/navigator wake-up.
F4	5A	Relay (K3). Relay (K25) (OPTION).
F5	5A	Diagnostics plug.
F6	5A	Transmission cut-off switch.
F7	10A	12 V plug.
F8	10A	Rear windshield wiper. Rear windshield washer.
F9	15A	Relay (K4 K21).
F10	20A	Window wind up.
F11	7,5A	Steering selection.
F12	5A	Trailer brake valve. Relay (K14).
F13	2A	Customer immobilizer (OPTION).
F14	5A	Car radio.
F15		Unused.
F16	15A	Side worklights (OPTION).
F17	15A	Pneumatic seat (OPTION).
F18	15A	3-pin 12 V connector (OPTION).
F19	2A	Immobilizer (OPTION).
F20	20A	Main ECU SPU 40-26.

F21	20A	Front worklights. Relay (K13).
F22	5A	Wheel alignment sensors.
F23	5A	Boom angle sensor.
F24	7,5A	Relay (K12).
F25	7,5A	Relay (K13 K16).
F26	10A	Stop switch.
F27	15A	Engine ECU wake-up. Engine sensor.
F28	2A	Transmission neutral.
F29		Unused.
F30	7,5A	Ventilation reversal.
F31	5A	Relay (K15) (OPTION). Pneumatic braking (OPTION).
F32	7,5A	Blue worklights (OPTION).
F33	7,5A	Boom head solenoid valve (OPTION).
F34	15A	Auxiliary ECU SPU 25-15 (OPTION).
F35	15A	Rear worklights.
F36	7,5A	Boom head electric power socket (OPTION).
F37	15A	Worklights on boom (OPTION).
F38	5A	Electric rear-view mirror and defrost (OPTION).
F39		Unused.
F40	15A	Central lubrication power supply (OPTION).

F41	20A	Main ECU SPU 40-26.
F42	5A	Relay (K2).
F43	5A	Information screen control console.
F44	5A	Diagnostics plug.
F45	5A	Roof light.
F46	7,5A	Horn.
F47	7,5A	Relay (K6).
F48	10A	Front windshield wiper automatic return.
F49	10A	Rear windshield wiper automatic return.
F50		Unused.
F51		Unused.

N°52702658

F80	F79	F78	F77	F76	F75	F74	F73	F72	F71
F61	F62	F63	F64	F65	F66	F67	F68	F69	F70
7.5A	7.5A	15A	15A	7.5A	7.5A	7.5A			
F60	F59	F58	F57	F56	F55	F54	F53	F52	F51
20A	15A	15A	7.5A	5A	5A				5A
F41	F42	F43	F44	F45	F46	F47	F48	F49	F50
20A	5A	5A	5A	5A	7.5A	7.5A	10A	10A	
F40	F39	F38	F37	F36	F35	F34	F33	F32	F31
15A	3A	5A	15A	7.5A	15A	15A	7.5A	7.5A	5A
F21	F22	F23	F24	F25	F26	F27	F28	F29	F30
20A	5A	5A	7.5A	7.5A	10A	15A	2A	5A	7.5A
F20	F19	F18	F17	F16	F15	F14	F13	F12	F11
20A	2A	15A	15A	15A	2A	5A	2A	5A	7.5A
F1	F2	F3	F4	F5	F6	F7	F8	F9	F10
20A	5A	5A	5A	5A	5A	10A	10A	15A	20A
F106	F105	F104	F103	F102	F101				
	30A	50A	60A	30A	20A				

F52		Unused.
F53		Unused.
F54		Unused.
F55		Unused.
F56	5A	Customer immobilizer (OPTION).
F57	7,5A	Car radio.
F58	15A	Auxiliary ECU SPU 25-15 (OPTION).
F59	15A	Relay (K4).
F60	20A	Lighting, horn and indicator switch.

F61	7,5A	Left turn signals.
F62	7,5A	Right turn signals.
F63	15A	Dipped beam headlights.
F64	15A	Main beam headlights.
F65	7,5A	Left parking lights.
F66	7,5A	Right parking lights.
F67	7,5A	Rear fog lights.
F68		Unused.
F69		Unused.
F70		Unused.
F71		Unused.
F72		Unused.
F73		Unused.
F74		Unused.
F75		Unused.
F76		Unused.
F77		Unused.
F78		Unused.
F79		Unused.
F80		Unused.

MAXIFUSE

F101		Unused.
F102	30A	Relay (K3).
F103	60A	Ignition switch.
F104	50A	Module 3 fuses (F41 - F60).
F105	30A	Air conditioning (OPTION).
F106		Unused.

RELAYS

K1	Front windshield wiper speed 1.
K2	Dashboard power supply.
K3	Fan/heating.
K4	Flashing light unit power supply.
K5	Transmission neutral.
K6	Rotating beacon.

K11	Transmission cut-off.
K12	Backup lights and backup alarm.
K13	Forward gear.
K14	Trailer brake test.
K15	Camera control (OPTION).
K16	Reverse gear.

K21	Flashing light unit.
K22	Hazard warning lights.

	K16		K15		K14
	K13		K12		K11
	K6		K5		K4
	K3		K2		K1
	K22		K21	N°52702658	

F80	F79	F78	F77	F76	F75	F74	F73	F72	F71
7,5A	7,5A	15A	15A	7,5A	7,5A	7,5A			
20A	15A	15A	7,5A	5A					5A
20A	5A	5A	5A	5A	7,5A	7,5A	10A	10A	
15A	3A	5A	15A	7,5A	15A	15A	7,5A	7,5A	5A
20A	5A	5A	7,5A	7,5A	10A	15A	2A	5A	7,5A
20A	2A	15A	15A	15A	2A	5A	2A	5A	7,5A
20A	5A	5A	5A	5A	5A	10A	10A	15A	20A
	30A	50A	60A	30A	20A				

21 - FUSES AND RELAYS UNDER THE ENGINE HOOD

- Open the engine hood, remove cover 1 to gain access to the fuses and relays.
Replace a blown fuse with a new fuse of the same quality and rating. Never use a repaired fuse.

MAXIFUSE

F71		Unused.
F72	20A	Relay (K36).
F73		Unused.
F74	60A	Relay (K41).
F75	30A	Relay (K35).
F76	20A	Fuel preheater (OPTION).

MINIFUSE

F81	5A	Sensor power supply NOx.
F82	5A	Unused.
F83	5A	Air intake valve.
F84	5A	Engine diagnostic plug
F85	5A	Engine ECU wake-up. Fuel preheater (OPTION).
F86	2A	Immobilizer (OPTION).
F87	10A	Supply pump "DEF".
F88	5A	Pressure line preheat "DEF".
F89	5A	Return line preheat "DEF".
F90	5A	Suction line preheat "DEF".

MAXIFUSE

F91	30A	Engine control power unit.
-----	-----	----------------------------

RELAYS

K24	Fuel preheater (OPTION).
K25	Fuel preheater (OPTION).

K31	Supply pump heating "DEF".
K32	Hose 1 heating "DEF".
K33	Hose 2 heating "DEF".
K34	Hose 3 heating "DEF".
K35	Heating system "DEF".
K36	Fuel pump.

K41	Preheat.
-----	----------

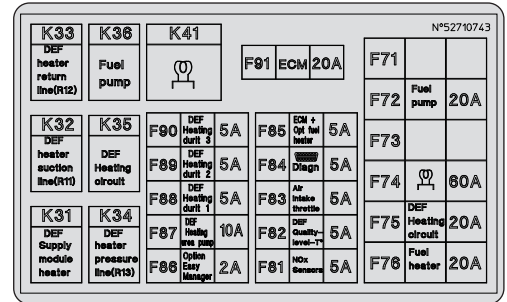

22 - FORWARD/NEUTRAL/REVERSE SELECTOR

When changing the direction of travel, the lift truck should be traveling at slow speed and not accelerating.

- FORWARD: Push the switch forward (position A).
- REVERSE: Push the switch backward (position B). Reversing lights and a backup alarm indicate that the lift truck is traveling in reverse.
- NEUTRAL: The switch must be in the neutral position (position C) to start the lift truck.

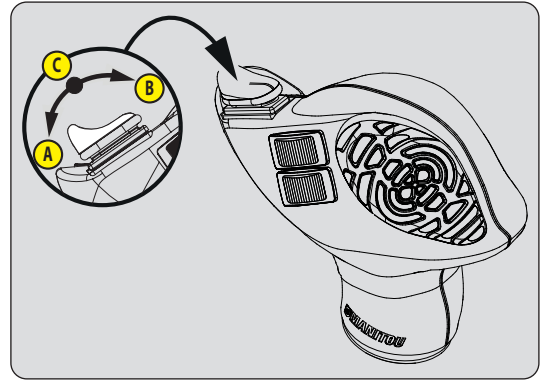

SAFETY FOR MOVING THE LIFT TRUCK

The operator must observe the following sequence to move the truck forward or backward:

- 1 - sit down correctly in the driver's seat,
- 2 - release the hand brake,
- 3 - engage forward or reverse gear.



N.B.: The alternate display of the forward or reverse section arrow on the information screen requires the selector to be set to neutral.

To stop the forklift truck without switching off the ignition, the following sequence must be followed:

- 1 - set the forward/reverse selector to neutral,
- 2 - apply the parking brake,
- 3 - get out of the lift truck.

N.B.: A discontinuous audible signal and a message on the screen will inform the driver if he has left the driver's cab without applying the parking brake.

23 - GEAR LEVER AND TRANSMISSION CUT-OFF

In order to change gear, it is necessary to cut off the transmission by pressing button 1 on the lever.

CONDITION OF USE OF GEARBOX RATIOS

On lift trucks such as these, equipped with torque converters, it is not necessary to systematically set off in first gear and work up through the gears.

⚠ IMPORTANT ⚠

The gearbox ratio selection should be made carefully depending on the work to be performed.

A poor choice may result in the extremely rapid rise of the gearbox oil temperature through excessive slipping of the converter, which could lead to serious gearbox damage (it is essential to stop and change the working conditions if the gearbox oil temperature indicator light comes on).

This poor choice may also result in the forklift truck's performance deteriorating in forward gear: When the forward force increases, the forward speed in the r ratio (for example, in 3rd gear) may be lower than the forward speed that could be obtained with the r-1 gear (in 2nd instead of 3rd).

In general, we would advise you to use the following gears according to the nature of the work being carried out.

- ON THE ROAD: Set off in 3rd gear and change up to 4th if the conditions and state of the road permit it. In hilly areas, set off in 2nd gear and change up to 3rd if the conditions and state of the road permit it.
- WITH A TRAILER ON THE ROAD: Set off in 2nd gear and change up to 3rd if the conditions and state of the road permit it.
- WHEN HANDLING: Use 3rd gear. In confined spaces use 2nd gear.
- LOADING (picking-up with bucket, manure fork, etc.): Use 2nd gear.
- EARTH MOVING: Use 1st gear.

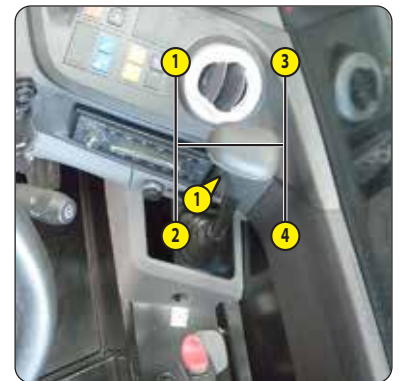

24 - STEERING SELECTION



⚠ IMPORTANT ⚠

*Before selecting one of the three steering possibilities, align the 4 wheels in relation to the lift truck axis.
Never change the steering mode whilst driving.*



The green indicator lights on the information screen  come on to indicate the alignment of the wheels relative to the lift truck.



A - STEERING SELECTION SWITCH

- Press the button to select the steering.
 -  Front steering wheels (road mode).
 -  Front and rear steering wheels in opposite directions (short steering).
 -  Front and rear steering wheels in the same direction (crab steering).

WHEEL ALIGNMENT CONTROL

⚠ IMPORTANT ⚠

*Check the alignment of the front and rear wheels each time the lift truck is started.
Regularly check the alignment of the wheels when using the lift truck.
The wheels must be aligned and the lift truck must be in front steering wheels mode when used on public roads.
A green light illuminates on the dashboard when the wheels are aligned.
Contact your dealer if you have any questions.*

- Select "short steering".
- Turn the steering wheel and bring the rear wheels into alignment until the  indicator lamps light on the rear wheels.
- Select "road driving".
- Turn the steering wheel and bring the rear wheels into alignment until the  indicator lamps light on the front wheels.



25 - PARKING BRAKE LEVER

To prevent accidental loosening or release, the lever is fitted with safety locking.

- Press button 1 to disable the safety lock.
- Pull the lever (position A) to apply the parking brake.
- Lower the lever (position B) to release the parking brake.

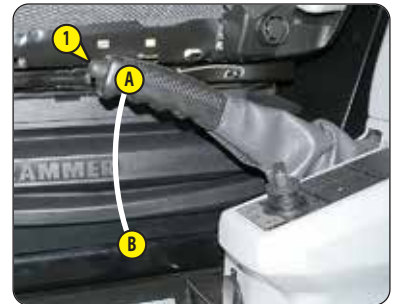

26 - ACCELERATOR PEDAL

ENGINE SPEED ACCELERATION

- Press the accelerator pedal to increase the engine speed and start moving the lift truck if forward or reverse gear is selected.

ENGINE SPEED DECELERATION

- Release the accelerator pedal and press on the service brake pedal to immobilize the lift truck.



27 - SERVICE BRAKE PEDAL AND TRANSMISSION CUT-OFF

The pedal applies on the front and rear wheels by an hydraulic brake system, and allows the lift truck to be slowed down and stopped. Depending on the position of the transmission cut-off switch, it enables the transmission to be cut off during the free travel (← PUSH BUTTON PANEL).



28 - FUNCTION FILES

These files contain the description of the hydraulic controls and the load charts for the attachments used on the lift truck.



29 - HYDRAULIC BOOM CONTROLS

⚠ IMPORTANT ⚠

Do not try to modify the hydraulic pressure of the system. If it malfunctions contact your dealer. ANY MODIFICATION INVALIDATES THE WARRANTY AND YOU WILL BE CRIMINALLY LIABLE IN THE EVENT OF AN ACCIDENT.

Use the hydraulic controls gently without jerking, to avoid incidents caused by shaking the lift truck.

N.B.: If necessary, operate the steering to reset the hydraulic control steering accumulator.

N.B.: When driving on the road, it is highly recommended (mandatory in Germany) that you cut off all the hydraulic movements (⇐ PUSH BUTTON PANEL).

HYDRAULIC CONTROLS ACTIVATION

This safety device prevents accidental operation of the hydraulic lifting, tilting, telescoping and attachment controls.

- Place your hand on the lever, activate the hydraulic controls by contact on sensor 1 and perform the hydraulic movement.
- Hydraulic controls activation is maintained on a timer while the lift truck is being used.
- If necessary, reactivate the hydraulic controls.

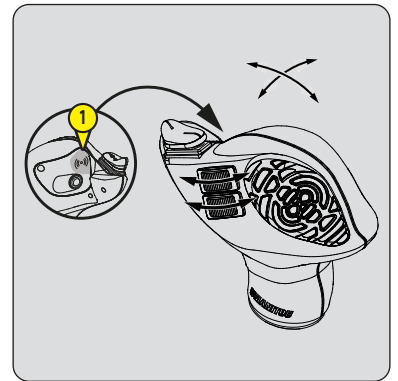

A1 - LIFTING

A2 - LOWERING

B1 - CROWD

B2 - DUMP

C1 - TELESCOPIC BOOM EXTENSION

C2 - TELESCOPIC BOOM RETRACTION

D1 - ATTACHMENT

D2 - ATTACHMENT

E - HYDRAULIC CONTROL (OPTION)

⇐ DESCRIPTION AND USE OF THE OPTIONS

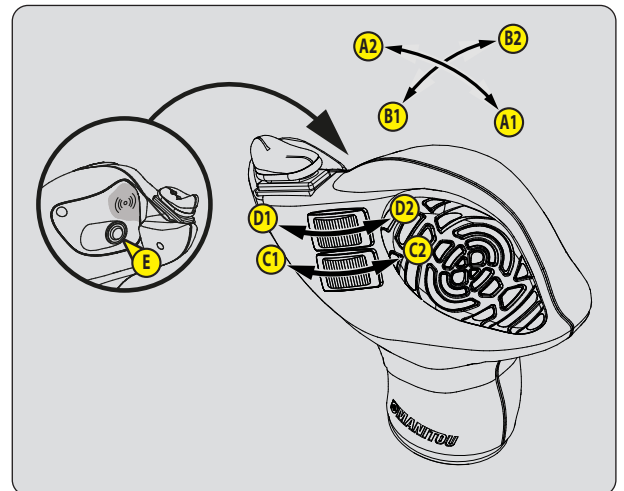

30 - LEVEL INDICATOR

Enables the operator to check that the lift truck is in the horizontal position.



31 - HEATER CONTROL

A - FAN CONTROL

This 4-speed control allows the air to be ventilated through the air vents.

B - TEMPERATURE CONTROL

Adjusts the temperature inside the cab.

- B1 - The fan pumps in the air at ambient temperature.
- B2 - The fan pumps in warm air.

The intermediate positions allow the temperature to be adjusted.



32 - AIR CONDITIONING CONTROLS (AIR CONDITIONING OPTION)

⚠ IMPORTANT ⚠

The air conditioning only works if the lift truck has been started.

When using your air conditioning, it is essential to work with the cab closed.

In winter: So as to ensure that the air conditioning unit is correctly operated and completely efficient, start up the compressor once a week, even for a short period of time, in order to lubricate the internal seals.

In cold weather: Warm the engine before switching on the compressor, in order to allow the coolant that has collected in the liquid state at the lowest point of the compressor's circuit to turn into gas under the effect of the heat given off by the engine, as the compressor is liable to be damaged by coolant in the liquid state.

If it seems to you that the air conditioning is not working properly, have it inspected by your dealer.

Never try to repair any faults yourself.

A - FAN CONTROL

This 4-speed control allows the air to be ventilated through the air vents.

B - TEMPERATURE CONTROL

Adjusts the temperature inside the cab.

- B1 - The fan pumps in cold air.
- B2 - The fan pumps in warm air.

The intermediate positions allow the temperature to be adjusted.

C - AIR CONDITIONING CONTROL

This control with a pilot light allows the air conditioning unit to be switched on.

HEATING MODE

- The controls must be adjusted in the following way:
 - C - Control with pilot light off.
 - B - At the desired temperature.
 - A - At the desired speed: 1, 2 or 3.

AIR CONDITIONING MODE

- The controls must be adjusted in the following way:
 - C - Control with indicator lamp on.
 - B - At the desired temperature.
 - A - At the desired speed: 1, 2 or 3.

DEFROST MODE

- The controls must be adjusted in the following way:
 - C - Control with indicator lamp on.
 - B - At the desired temperature.
 - A - At speed 2 or 3.
- For optimum effectiveness, close the heating vents.



33 - HEATING VENTS

These swiveling heating vents, which can be shut off, allow you to direct and adjust the flow inside the cab.

34 - WINDSHIELD DEFROSTER VENTS

For optimum effectiveness, close the heating vents.

35 - WINDOW WINDER

36 - DOOR OPENING AND CLOSING HANDLE

Two keys are provided with the lift truck to enable the cab to be locked.

- Press the door handle trigger to open the door.
- Pull on the handle to close the door.



37 - REAR WINDOW STAY



38 - STORAGE NET

Ensure that the operator's manual is in its place in the storage net.

39 - STORAGE



40 - CUP HOLDER



41 - FRONT HEADLIGHTS

- A - Front left-hand indicator light.
- B - Front left-hand dipped headlight.
- C - Front left-hand headlight.
- D - Front left-hand sidelight.
- E - Front right-hand indicator light.
- F - Front right-hand low beam headlight.
- G - Front left-hand high beam headlight.
- H - Right front sidelight.
- I - Sidelights.

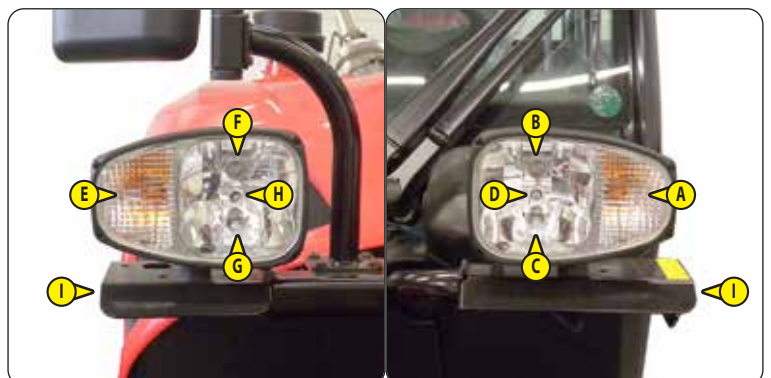

42 - REAR LIGHTS

- A - Rear left-hand indicator light.
- B - Rear left-hand stop light.
- C - Left rear light.
- D - Rear fog light.
- E - Rear reversing light.
- F - Right rear light.
- G - Rear right-hand stop light.
- H - Rear right-hand indicator light.

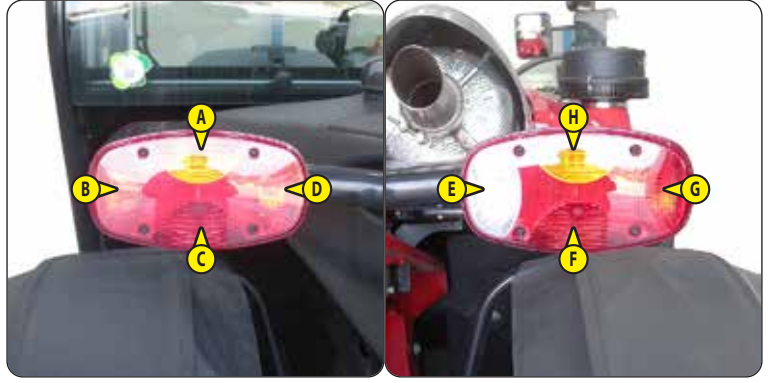

43 - ROTATING BEACON LIGHT

The magnetic rotating beacon light must be clearly visible on the roof of the cab and plugged into socket 1.



44 - SUN VISOR

45 - ROOF LIGHT

46 - COAT HOOK



47 - INTERNAL REAR-VIEW MIRROR

48 - TELEPHONE HOLDER



49 - STEERING WHEEL ADJUSTMENT LEVER

This handle enables the angle and height of the steering wheel to be adjusted.

- Pull the knob backward.
- Adjust the steering wheel to the desired position.
- Push the knob back to lock the steering wheel in position.



50 - EMERGENCY HAMMER



51 - BOOM SAFETY WEDGE

⚠ IMPORTANT ⚠

Only use the wedge supplied with the lift truck.

The lift truck is equipped with a boom safety wedge which must be installed on the rod of the lifting cylinder when working beneath the boom (☞ 1 - OPERATING AND SAFETY INSTRUCTIONS).



52 - FUEL TANK

As far as possible, keep the fuel tank well filled in order to minimize condensation due to the atmospheric conditions.

⚠ IMPORTANT ⚠

Never smoke or approach with a flame during filling operations or when the tank is open.

Never refill while the engine is running.

- If necessary, add diesel (☞ 3 - MAINTENANCE: LUBRICANTS AND FUEL).
- Remove the cap 1.
- Fill the fuel tank with clean diesel filtered through the filler port.
- Refit the cap.
- Visually check that there is no leakage in the tank and pipes.

N.B.: A locking tank cap is available as an OPTION.



53 - TANK "DEF" (Diesel Exhaust Fluid)

⚠ IMPORTANT ⚠

*Diesel exhaust fluid is corrosive: protect the bodywork and wear personal protective equipment (gloves and goggles).
The Diesel Exhaust Fluid level is important. Operating with a low or empty DEF tank level may affect engine performance.*

- If necessary, add diesel exhaust fluid (↩ 3 - MAINTENANCE: LUBRICANTS AND FUEL).
- Remove the cap 1.
- Slowly fill the tank to the bottom of the filler neck.
- Always maintain a good level to avoid alternation of the product.
- Refit the cap.

N.B.: A locking tank cap is available as an OPTION.



QUALITY "DEF" (Diesel Exhaust Fluid)

The diesel exhaust fluid quality can be measured using a refractometer. The diesel exhaust fluid must comply with standard ISO 22241-1 with a urea concentration of 32.5%.

Refractometer (MANITOU part number: 959709)

STORAGE "DEF" (Diesel Exhaust Fluid)

Up to 4 months without using the lift truck, check the quality of the diesel exhaust fluid with a refractometer.

Beyond 4 months, replace the diesel exhaust fluid. Empty and rinse the tank.

N.B.: For a prolonged shutdown of the lift truck, ↩ 1 - OPERATING AND SAFETY INSTRUCTIONS: IF THE LIFT TRUCK IS NOT TO BE USED FOR A LONG TIME.

TOWING DEVICE

1 - CHASSIS-MOUNTED FRONT TOWING HOOK	2-67
2 - CLEVIS HITCH	2-67
3 - AUTOMATIC CLEVIS HITCH (OPTION)	2-67
4 - CLEVIS HITCH ON COUPLING LADDER (OPTION)	2-68
5 - AUTOMATIC CLEVIS HITCH ON COUPLING LADDER (OPTION)	2-68
6 - BALL HITCH ON COUPLING LADDER (OPTION)	2-69
7 - FIXED PIN ON COUPLING LADDER (OPTION)	2-69
8 - HYDRAULIC TOWING HOOK (OPTION)	2-70
9 - REAR ELECTRIC SOCKET	2-70
10 - HYDRAULIC TRAILER BRAKING (OPTION)	2-71
11 - PNEUMATIC TRAILER BRAKE (OPTION)	2-71

⚠ IMPORTANT ⚠

Do not tow a trailer or an attachment that is not in perfect working condition.

Using a trailer in poor condition may affect the lift truck's steering and braking, and hence the safety of the assembly.

If a third party helps in coupling or uncoupling the trailer, this person must remain visible to the driver at all times and must wait until the lift truck has stopped, the handbrake is on and the engine is switched off before performing the operation.

Located at the rear of the lift truck, this device is used to attach a trailer. Its capacity is limited for each lift truck by the authorized gross vehicle weight, tractive effort and maximum vertical force on the coupling point. This information is given on the manufacturer's plate fixed to each lift truck (➤ IDENTIFICATION OF THE LIFT TRUCK).

- To use a trailer, see current regulations in your country (maximum running speed, braking, maximum weight of trailer, etc.).
- Verify the trailer's condition before using it (tire condition and pressures, electrical connection, hydraulic hose, brake system, etc.).

N.B.: Our tractor type-approved lift trucks are not compatible for use with trailers fitted with the ISO7638 socket.

1 - CHASSIS-MOUNTED FRONT TOWING HOOK

⚠ IMPORTANT ⚠

This pin is only intended for towing or winching the lift truck in the event of a breakdown.

⚠ 3 - MAINTENANCE: OCCASIONAL OPERATION for towing or winching the lift truck.



2 - CLEVIS HITCH

⚠ IMPORTANT ⚠

Be careful not to get your fingers caught or crushed during this operation.

Do not forget to put the cotter pin back in place.

When uncoupling, make sure that the trailer is supported independently

COUPLING AND UNCOUPLING THE TRAILER

- To couple the trailer, position the lift truck as close as possible to the trailer ring.
- Apply the parking brake and switch off the engine.
- Remove the pin 1, lift the towing pin 2 and place or remove the trailer ring.

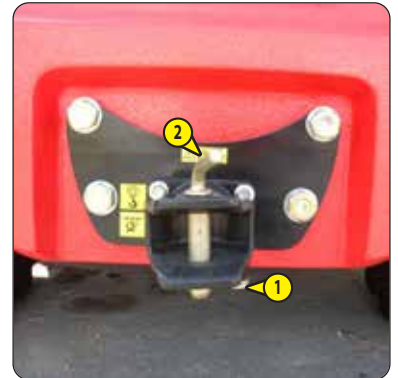

3 - AUTOMATIC CLEVIS HITCH (OPTION)

⚠ IMPORTANT ⚠

When uncoupling, make sure that the trailer is supported independently

COUPLING THE TRAILER

- Remove the automatic towing pin using lever 1.
- Back up the lift truck so that the trailer ring slots into the automatic hook.

N.B.: The pin closes automatically when the trailer ring touches the back of the clevis.
The pin can be lowered by hand using lever 1.

UNCOUPLING THE TRAILER

- Lift the pin using lever 1 to uncouple the trailer.



4 - CLEVIS HITCH ON COUPLING LADDER (OPTION)

⚠ IMPORTANT ⚠

*Be careful not to get your fingers caught or crushed during this operation.
When uncoupling, make sure that the trailer is supported independently*

- Position the lift truck as close as possible to the trailer ring.
- Apply the parking brake and switch off the engine.

ADJUSTING THE CLEVIS HITCH

- Lift the handle 1 and pivot it upwards to release the pins 2 on either side of the ladder.
- Support the clevis and adjust it according to the height of the trailer ring.
- Pivot the handle 1 downwards to engage the 2 pins in the ladder and release the handle.

COUPLING AND UNCOUPLING THE TRAILER

- Remove the towing pin 3 and place or remove the trailer ring.
- Refit and lock towing pin 3 in position.

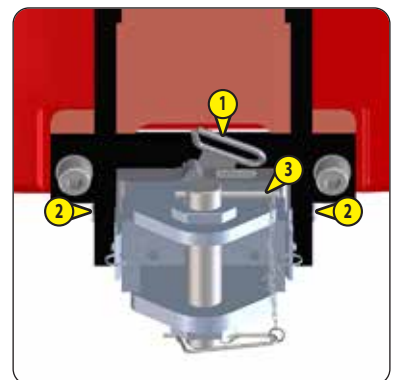
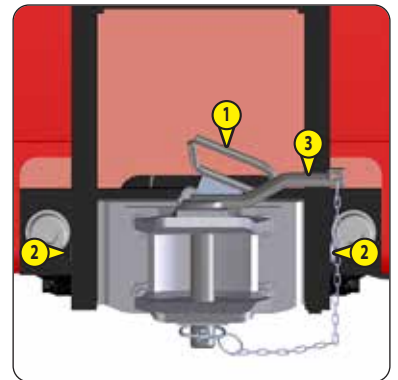

5 - AUTOMATIC CLEVIS HITCH ON COUPLING LADDER (OPTION)

⚠ IMPORTANT ⚠

*Be careful not to get your fingers caught or crushed during this operation.
When uncoupling, make sure that the trailer is supported independently*

- Position the lift truck as close as possible to the trailer ring.

ADJUSTING THE CLEVIS HITCH

- Lift the handle 1 and pivot it upwards to release the pins 2 on either side of the ladder.
- Support the clevis and adjust it according to the height of the trailer ring.
- Pivot the handle 1 downwards to engage the 2 pins in the ladder and release the handle.

COUPLING THE TRAILER

- Remove the automatic towing pin using lever 3.
- Back up the lift truck so that the trailer ring slots into the automatic hook.

N.B.: The pin closes automatically when the trailer ring touches the back of the clevis. The pin can be lowered by hand using lever 3.

UNCOUPLING THE TRAILER

- Lift the pin using lever 3 to uncouple the trailer.

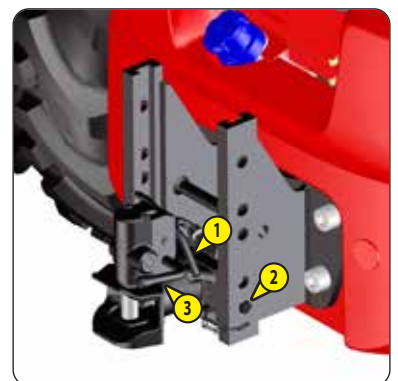

6 - BALL HITCH ON COUPLING LADDER (OPTION)

⚠ IMPORTANT ⚠

*Be careful not to get your fingers caught or crushed during this operation.
When uncoupling, make sure that the trailer is supported independently*

- Position the lift truck as close as possible to the trailer ring.

ADJUSTING THE CLEVIS HITCH

- Lift the handle 1 and pivot it upwards to release the pins 2 on either side of the ladder.
- Support the clevis and adjust it according to the height of the trailer ring.
- Pivot the handle 1 downwards to engage the 2 pins in the ladder and release the handle.

COUPLING AND UNCOUPLING THE TRAILER

- Remove the cotter pin 3 and the locking pin 4.
- Lift the hitch bolt 5.
- Place or remove the coupling head of the trailer on the ball hitch.
- Refit the hitch bolt 5, the locking pin 4 and the cotter pin 3.

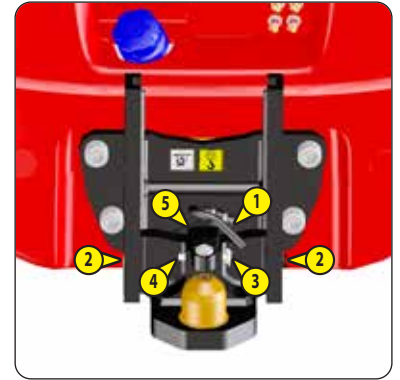

7 - FIXED PIN ON COUPLING LADDER (OPTION)

⚠ IMPORTANT ⚠

*Be careful not to get your fingers caught or crushed during this operation.
When uncoupling, make sure that the trailer is supported independently*

- Position the lift truck as close as possible to the trailer ring.

ADJUSTING THE CLEVIS HITCH

- Lift the handle 1 and pivot it upwards to release the pins 2 on either side of the ladder.
- Support the clevis and adjust it according to the height of the trailer ring.
- Pivot the handle 1 downwards to engage the 2 pins in the ladder and release the handle.

COUPLING AND UNCOUPLING THE TRAILER

- Remove the cotter pin 3 and the locking pin 4.
- Lift the hitch bolt 5.
- Place or remove the coupling head of the trailer on the fixed pin.
- Refit the hitch bolt 5, the locking pin 4 and the cotter pin 3.

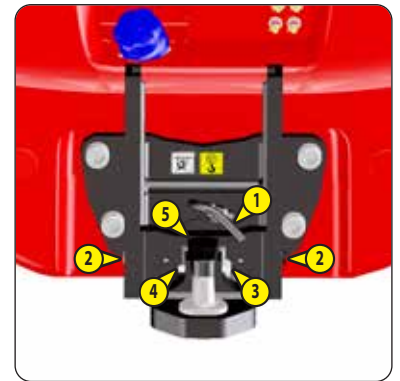

8 - HYDRAULIC TOWING HOOK (OPTION)

⚠ IMPORTANT ⚠

*Never use the tow hook to raise the rear of the lift truck (when changing the rear wheel for example).
When uncoupling, make sure that the trailer is supported independently*

- Select the rear attachment hydraulic line 
- Push switch 1 forwards to release the locking pin securing the hook 2.
- Pull on the knob 3 and hold in position.
- Push switch 1 backwards to lower the towing hook.
- Release knob 3.
- Couple or uncouple the trailer.
- Push switch 1 forwards to fully raise the towing hook.
- Next, push switch 1 backwards to bring the locking pin into contact with the hook 2.

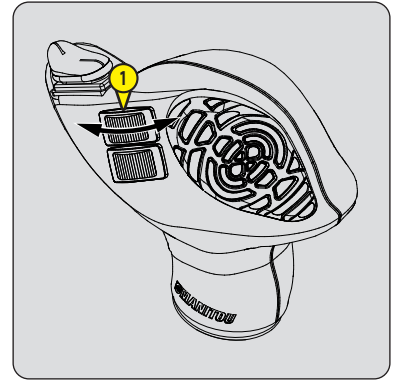
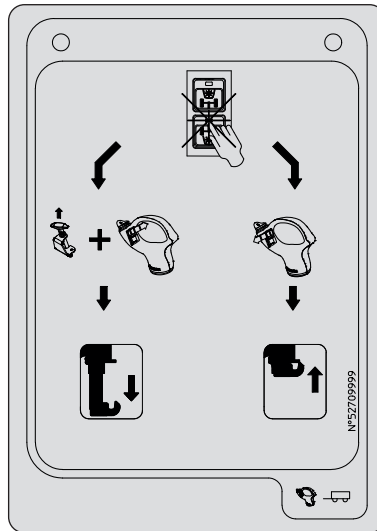

9 - REAR ELECTRIC SOCKET

- Connect the male plug to the female socket 1 on the lift truck and make sure the lights of the trailer or the light bar are working properly.



10 - HYDRAULIC TRAILER BRAKING (OPTION)

TRAILER BRAKE WITH A DOUBLE "SL" AND "CL" LINE

- Connect the brake hose to the lift truck "CL" line 1.
- Connect the brake release hose to the lift truck "SL" line 2.
- Make sure the trailer brakes are working properly and test the effects of braking before taking the trailer onto the public highway.

DOUBLE LINE TRAILER BRAKE TEST

- Press button B to display the "PREFERENCES" menu
- Turn knob A to navigate through the menus and sub-menus.

TRANSMISSION	>	TRAILER BRAKE TEST
--------------	---	--------------------



11 - PNEUMATIC TRAILER BRAKE (OPTION)

The pressure gage 1 indicates the working pressure of the pneumatic circuit (8 bar).

- Connect the brake hose to the lift truck "J" line.
- Connect the brake release hose to the lift truck "R" line.
- Make sure the trailer brakes are working properly and test the effects of braking before taking the trailer onto the public highway.

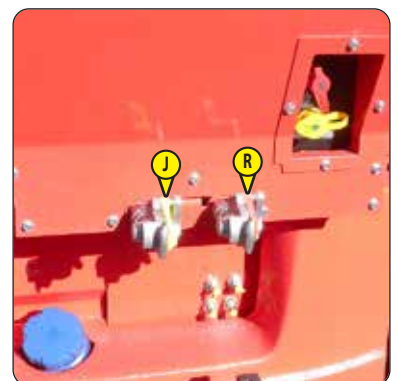

DESCRIPTION AND USE OF THE OPTIONS

1 - WINDSHIELD GRILLE	2-73
2 - CAB FIRE EXTINGUISHER	2-73
3 - ANGULAR SECTOR ON BOOM	2-73
4 - MARKS ON BOOM	2-73
5 - AUTOMATIC CENTRAL GREASING	2-74
6 - 3 POLE 12V CONNECTOR	2-74
7 - PIN PAD "EasyMANAGER"	2-74
8 - ELECTRICAL ADJUSTMENT OF MAIN RIGHT REAR-VIEW MIRROR	2-75
9 - REAR AND SIDE CAMERAS	2-75
10 - BOOM HEAD CAMERA	2-75
11 - BOOM ELECTRICAL PREDISPOSITION	2-76
12 - FUEL PREHEATER	2-76
13 - ENGINE BLOCK HEATER	2-76
14 - ENGINE SPEED REGULATOR	2-77
15 - "ECO STOP" ENGINE	2-77
16 - EXTERIOR DRAIN-BACK	2-77
17 - ATTACHMENT EASY HYDRAULIC CONNECTION	2-78
18 - ATTACHMENT HYDRAULIC LOCKING	2-78
19 - BOOM HEAD ELECTROVALVE	2-79
20 - BOOM HEAD ELECTROVALVE + HYDRAULIC ATTACHMENT LOCKING	2-80
21 - ATTACHMENT CIRCUIT FLOW RATE LIMITER	2-81
22 - ATTACHMENT CIRCUIT MANUAL OVERRIDE	2-81
23 - BOOM SUSPENSION	2-82
24 - COMBINED HYDRAULIC MOVEMENTS	2-82
25 - SEMI-AUTOMATIC WHEEL ALIGNMENT	2-83
26 - DOUBLE-ACTING REAR HYDRAULIC CONTROL PREDISPOSITION	2-83
27 - TWO DOUBLE-ACTING REAR HYDRAULIC CONTROL PREDISPOSITIONS	2-84
28 - HYDRAULIC TRAILER HOOK + DOUBLE-ACTING REAR HYDRAULIC CONTROL PREDISPOSITION	2-84

1 - WINDSHIELD GRILLE

DESCRIPTION

The windshield grille provides additional protection for the operator from any external elements spattered on the windshield.

This grille must be removable from inside the cab to enable an emergency exit.

EMERGENCY EXIT

- After breaking the windshield with the emergency hammer, push (with force) on the windshield grid at A to remove it.



2 - CAB FIRE EXTINGUISHER

⚠ IMPORTANT ⚠

Regularly check your fire extinguisher.

After use, replace the fire extinguisher with a new one of the same type.



3 - ANGULAR SECTOR ON BOOM

The angular sector displays the boom angle, and thus improves the reading of the load charts.



4 - MARKS ON BOOM

The marking indicates the outreach of the boom and therefore improves reading of the load charts.

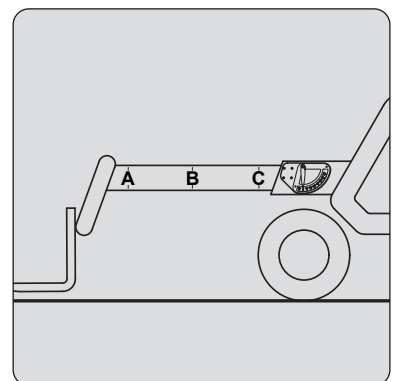

5 - AUTOMATIC CENTRAL GREASING

⚠ IMPORTANT ⚠

Before using the lift truck, check the condition of the greasing unit and check the grease level, topping it up, if necessary (↩ 3 - MAINTENANCE: 10H - DAILY MAINTENANCE OR EVERY 10 HOURS OF SERVICE).

Never use the lift truck with the grease tank empty.

When washing the lift truck with a high-pressure cleaner, the greasing unit must be protected from splashes.

This option ensures automatic lubrication of all of the lift truck's greasing points from start-up.

After turning on the ignition, check the automatic greasing control indicator light 1:

- Light on for 3s = system OK.
- Light flashing every 0.5s = greasing cycle in progress.
- Light flashing every 1s = grease level low (error code 8C-7F07E.11).
- Light on continuous = grease tank empty or system error.

In the event of a system error, perform a test cycle by pressing test button 2:

- Press once and the light flashes once every 2 seconds and initiates the test on output 1.
- Press twice and the light flashes twice every 2 seconds and launches the test on output 2.

N.B.: After an interruption, when the system is powered back on, the greasing cycle continues where it stopped previously.

If the system error persists, contact your dealer as soon as possible.



6 - 3 POLE 12V CONNECTOR

For 12 V appliance and max. amperage 16A.



7 - PIN PAD "EasyMANAGER"

A code must be created for the operator via the "EasyMANAGER" portal. For more information, contact your dealer.

OPERATION

BY ID CODE

- Switch on lift truck ignition, LED 1 comes on.
- Enter your ID code and confirm by pressing the "V" key.
- LED 2 comes on to confirm the operator's identification.
- Immediately start the lift truck, otherwise the identification process is canceled and LED 2 turns red.

N.B.: In case of an input error, LED 2 lights up red, press the "X" key, and wait 10 seconds before entering the correct identification code.

BY ID CARD

- Switch on lift truck ignition, LED 1 comes on.
- Present your ID card; an audible beep confirms that the card has been read.
- LED 2 comes on to confirm the operator's identification.
- Immediately start the lift truck, otherwise the identification process is canceled and LED 2 turns red.



8 - ELECTRICAL ADJUSTMENT OF MAIN RIGHT REAR-VIEW MIRROR



9 - REAR AND SIDE CAMERAS

To activate a camera:

- Turn knob A to select the rear or side camera .
- The screen displays the view of the selected camera.

The rear camera (SafeView) can be configured in automatic mode when in reverse gear.

- Press button B to display the "PREFERENCES" menu.
- Turn knob A to select the menu.

SYSTEM	>	CAMERA (OPTION)
--------	---	-----------------

- Press knob A to confirm.
- Activate the automatic configuration using knob A.
- Press knob A to confirm.



10 - BOOM HEAD CAMERA

To activate the camera:

- Turn knob A to select the boom head camera .
- The screen displays the view of the selected camera.

The boom head camera (HighView) can be configured in automatic mode as soon as the boom angle reaches 25°. When the boom goes back down, the previous screen reappears.

- Press button B to display the "PREFERENCES" menu.
- Turn knob A to select the menu.

SYSTEM	>	CAMERA (OPTION)
--------	---	-----------------

- Press knob A to confirm.
- Activate the automatic configuration using knob A.
- Press knob A to confirm.

N.B.: "Manual" selection of the boom head camera from the information screen activates it permanently. The boom head camera (HighView) can be combined with the rear and side cameras option (SafeView).

BOOM HEAD CAMERA INSTALLATION

- Lower the boom as far as it will go and turn off the lift truck ignition.
- Position the indexing finger 1 and tighten the thumbwheels 2.
- Point the camera using the thumbwheel 3.

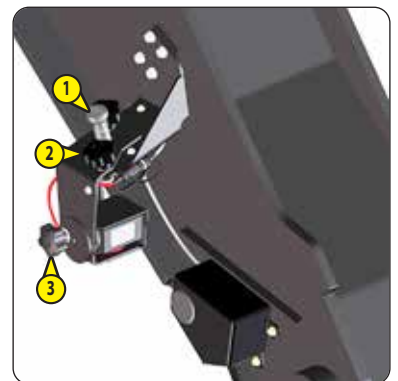

11 - BOOM ELECTRICAL PREDISPOSITION

Enables an electrical function to be used at the top of the boom foot or on the boom head.

OPERATION

- Press the switch. The indicator  will come on when the function is enabled.



12 - FUEL PREHEATER

The paraffin particles found naturally in diesel crystallize at low temperatures. The fuel preheater limits their accumulation in the filter.

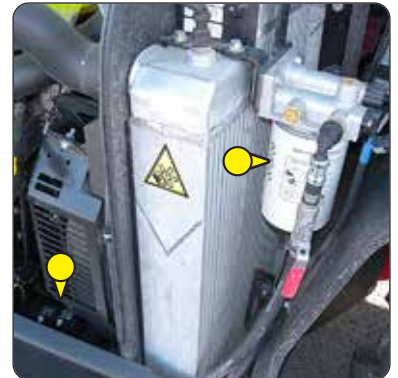

13 - ENGINE BLOCK HEATER

Enables the engine to be kept warm during prolonged periods of stoppage and thus improves engine starting.

ENVIRONMENTAL CONDITIONS FOR USE:

- Maximum ambient temperature for using preheat: + 25 °C

CONDITIONS FOR CONNECTION AND USE OF PREHEATING:

- The preheating system should not be used for an external ambient temperature higher than + 25 °C.
- It is essential that the power supply to the preheating system:
 - Is effected with a cable that conforms to the installation standards in force and contains a protective earth conductor.
 - Contains an appropriate sectioning system.
 - Include an appropriate short-circuit protection system (fuses or circuit breaker) and a ground-fault circuit breaker, sensitive to 30 mA.
- Only connect to and disconnect from the power supply while the unit is switched off and the engine is stopped.

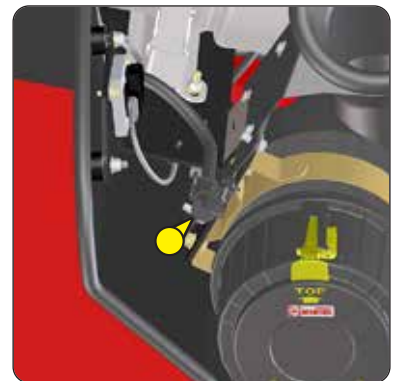

⚠ IMPORTANT ⚠

Make sure that the electrical extension is still correctly stored in its place in the document holder net.

14 - ENGINE SPEED REGULATOR



⚠ IMPORTANT ⚠

The engine speed regulator cannot under any circumstances be used while driving on the road.



USING THE REGULATOR

- Control the engine speed with lever 1.

SPEED MEMORIZATION

- Control the engine speed with lever 1 or the accelerator pedal.
- Hold down the  button to memorize the engine speed.
- Press the  button again or operate lever 1 to return to idle speed.

ACTIVATING THE MEMORIZED ENGINE SPEED

- Press the  button to activate the memorized engine speed.
- Confirm by pressing the  button a second time or pressing knob A.
- Press the  button again or operate lever 1 to return to idle speed.



15 - "ECO STOP" ENGINE

This function can take charge of engine shutdown to reduce consumption. It can be used if all of the following conditions are met within a timeframe defined by the operator.

- Engine on.
- Engine speed less than 1,000 rpm.
- No driver presence.
- No manual override in progress.
- No "stationary lift truck" exhaust regeneration".
- Parking brake applied.
- Engine coolant temperature higher than 40 °C.

TIME DELAY ADJUSTMENT

- Press button B to display the "PREFERENCES" menu
- Turn knob A to navigate through the menus and sub-menus.

ENGINE	>	ECO STOP
--------	---	----------

- Select the time delay (between 1 and 20 minutes) and press knob A to confirm.

OPERATION

- Press the  button to activate. The indicator light will come on, showing that it is in use.

⚠ IMPORTANT ⚠

The "ECO STOP" function does not under any circumstances replace lift truck shutdown. You must shut down the lift truck at the end of the job or the end of the day (<1 - OPERATING AND SAFETY INSTRUCTIONS: OPERATOR INSTRUCTIONS: OPERATING INSTRUCTIONS WITH AND WITHOUT LOAD: G - STOPPING THE LIFT TRUCK).



16 - EXTERIOR DRAIN-BACK

Enables connection of a hydraulic attachment for which drain-back is required.



17 - ATTACHMENT EASY HYDRAULIC CONNECTION

For easy connection and disconnection of hydraulic attachments.

PUSH BUTTON OPERATION

- Switch on lift truck ignition.
- Press for two seconds on pushbutton 1 to release the attachment circuit hydraulic pressure.
- Connect or disconnect the quick couplers of the hydraulic attachment (≤ 4 - ADAPTABLE ATTACHMENTS AS AN OPTION ON THE RANGE: PICKING UP THE ATTACHMENTS).



NAVIGATION BUTTON OPERATION

- Switch on lift truck ignition.
- Press button B to display the "PREFERENCES" menu
- Turn knob A to navigate through the menus and sub-menus.

HYDRAULIC > EASY CONNECT SYSTEM

- Press knob A to confirm.
- Connect or disconnect the quick couplers of the hydraulic attachment (≤ 4 - ADAPTABLE ATTACHMENTS AS AN OPTION ON THE RANGE: PICKING UP THE ATTACHMENTS).



18 - ATTACHMENT HYDRAULIC LOCKING

Enables the attachment to be locked onto the carriage and a hydraulic attachment to be used by the same circuit.

⚠ IMPORTANT ⚠

Once the attachment is locked, return valve 1 to position B to prevent accidental release of the attachment.
OR

Press the button  to shut off the attachment circuit hydraulic movements. The indicator lamp indicates it is in use.

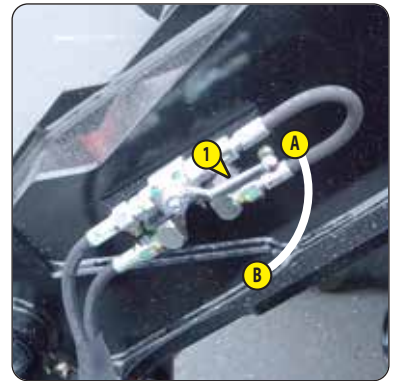

ATTACHMENT LOCKING CONTROL

- Set valve 1 to position A.
- Push switch 2 forward to lock the attachment and backward to release it.
- Set valve 1 to position B.

HYDRAULIC ATTACHMENT CONTROL

- Set valve 1 to position B.
- Push switch 2 forward or backward.

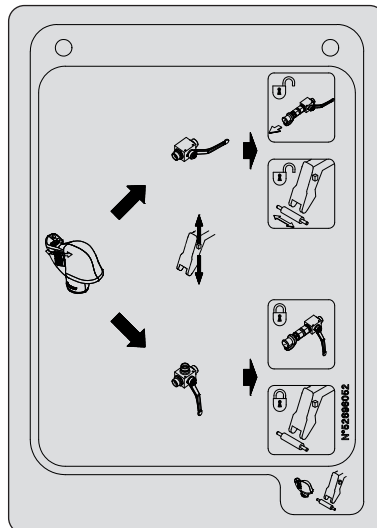
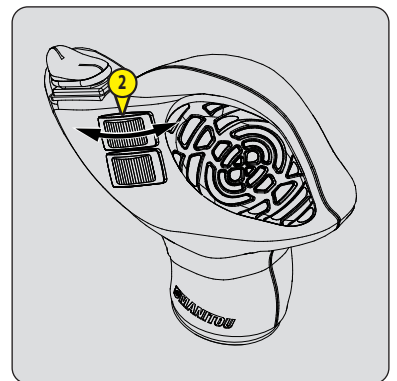

19 - BOOM HEAD ELECTROVALVE

Enables use of two hydraulic functions on the attachment circuit.

N.B.: For ease of connection of the quick-release couplers, decompress the hydraulic circuit by pressing button 1 on the electrovalve.

ATTACHMENT LINE CONTROL "C1-C4"

- Turn off the  switch (indicator lamp off).
- Push switch 2 forward or backward to control the attachment line "C1-C4".

ATTACHMENT LINE CONTROL "C1-C4 / C2-C3"

- Turn on the  switch (indicator lamp on).
- Push switch 2 forward or backward to control the attachment line "C1-C4".
- Hold down button 3 and push switch 2 forward or backward to control the attachment line "C2-C3".

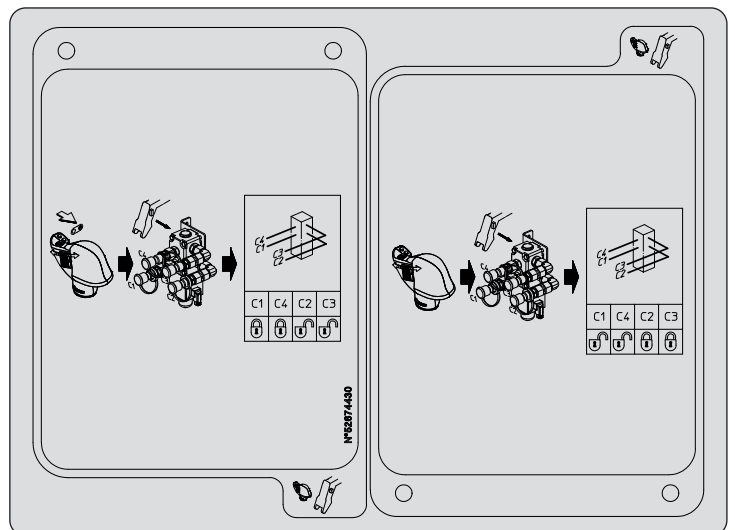
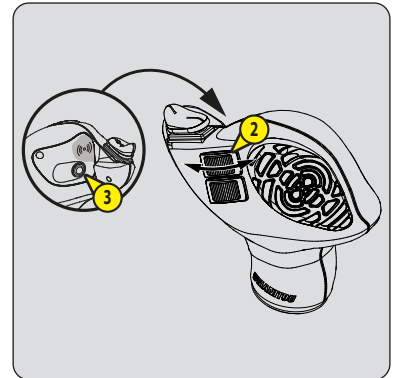
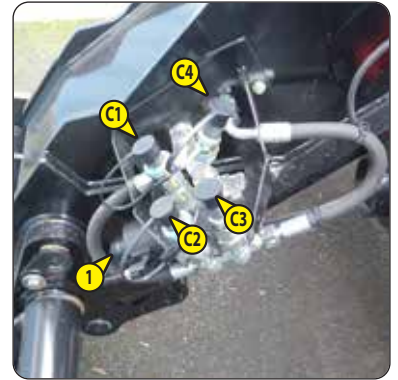

20 - BOOM HEAD ELECTROVALVE + HYDRAULIC ATTACHMENT LOCKING

The addition of these two options on the attachment line allows two hydraulic functions to be used and locks the attachment onto the carriage.

N.B.: For ease of connection of the quick-release couplers, decompress the hydraulic circuit by pressing button 1 on the electrovalve.

⚠ IMPORTANT ⚠

Once the attachment is locked, return valve 2 to position B to prevent accidental release of the attachment.

ATTACHMENT LINE CONTROL "C1-C4"

- Turn off the  switch (indicator lamp off).
- Push switch 3 forward or backward to control the attachment line "C1-C4".

ATTACHMENT LINE CONTROL "C1-C4 / C2-C3" + HYDRAULIC ATTACHMENT LOCKING

- Turn on the  switch (indicator lamp on).
- Set valve 2 to position B.
- Push switch 3 forward or backward to control the attachment line "C1-C4".
- Hold down button 4 and push switch 3 forward or backward to control the attachment line "C2-C3".

LOCKING AN ATTACHMENT

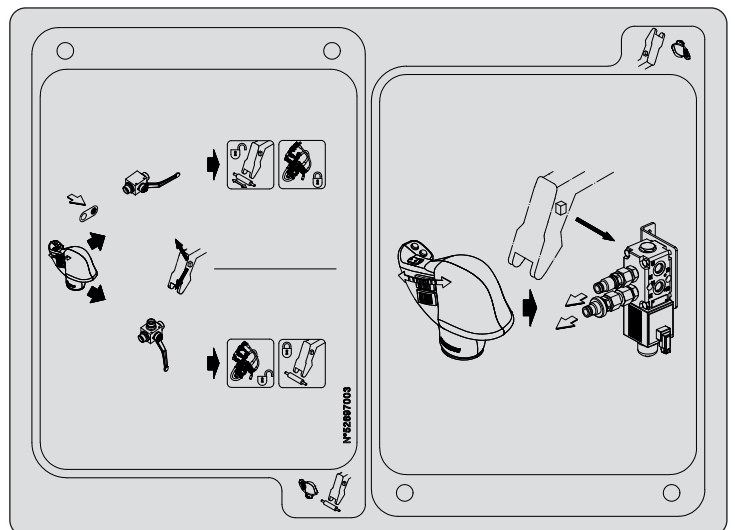
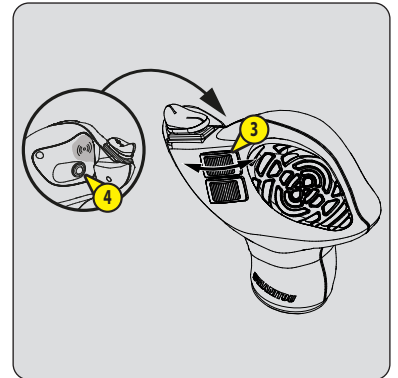
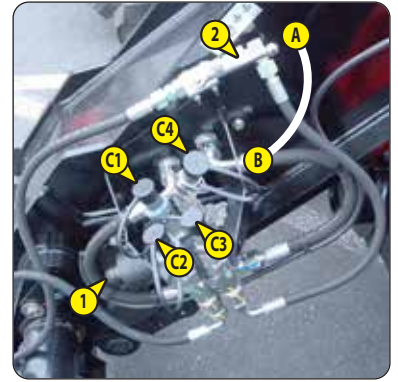

- Turn on the  switch (indicator lamp on).
- Set valve 2 to position A.
- Hold down button 4 and push button 3 forward to lock the attachment and backward to release it.
- Set valve 2 to position B.



21 - ATTACHMENT CIRCUIT FLOW RATE LIMITER

FLOW RATE MEMORIZATION

- Hold down the  button;  will appear on the information screen.

N.B.: Depending on the OPTIONS, you can have two attachment circuits  . Press button B to select the second circuit.

- Turn knob A to limit the flow rate to a value of your choice.
- Press knob A to confirm and proceed to the adjustment of the other line.
- Press knob A again to confirm and exit the setting menu.



ACTIVATING THE MEMORIZED FLOW RATE

- Press the  button to activate. The indicator light will come on, showing that it is in use.
- Press the button again to deactivate.

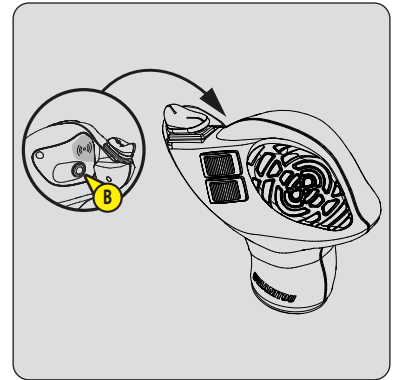





22 - ATTACHMENT CIRCUIT MANUAL OVERRIDE

⚠ IMPORTANT ⚠

This OPTION should only be used with an attachment that requires continuous hydraulic movement such as: a sweeper, feed wagon, mixer, sprayer, etc. It is strictly prohibited for handling operations and for all other attachments (winch, crane, crane jib with winch, hook, etc.).



USING AND STORING MANUAL OVERRIDE

- Turn the navigation knob A to select work mode .
- Press knob A or press and hold the ;  will appear on the information screen.

N.B.: Depending on the OPTIONS, you can have two attachment circuits  . Press button B to select the second circuit.

- Turn the knob A to select the line.
- Confirm by pressing knob A.
- Turn knob A to set the desired flow rate.
- Press knob A to confirm and save.

ACTIVATING THE STORED MANUAL OVERRIDE

- Press the  button to activate manual override.
- Confirm by pressing the  button a second time or pressing knob A.
- Press the  button again to deactivate.



23 - BOOM SUSPENSION

Boom suspension absorbs the shocks to the lift truck on uneven ground (ex. handling straw in a field).

⚠ IMPORTANT ⚠

When you make a hydraulic downward or tilting movement, boom suspension is temporarily disabled and the button's indicator light  goes off. Boom suspension is active from 5 km/h.

- Press the  button to activate. The indicator light will come on, showing that it is in use.
- Press the button again to deactivate.
- When the engine is off, boom suspension is automatically deactivated.

N.B.: Forced boom suspension  allows it to be used at less than 5 km/h.

24 - COMBINED HYDRAULIC MOVEMENTS

This function allows several hydraulic movements to be combined.

- A1 - LIFTING
- A2 - LOWERING
- B1 - CROWD
- B2 - DUMP

COMBINED HYDRAULIC MOVEMENTS

- A1/B1 - LIFTING + CROWD
- A2/B1 - LOWERING + CROWD
- A1/B2 - LIFTING + DUMP
- A2/B2 - LOWERING + DUMP

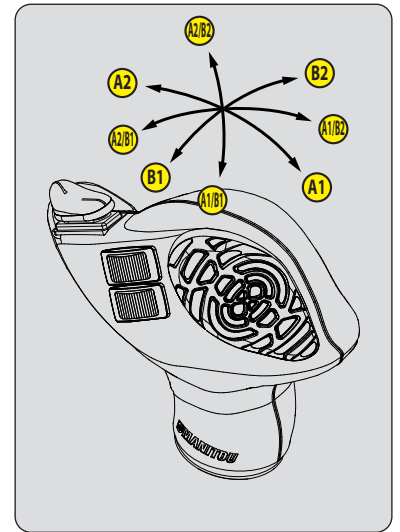

25 - SEMI-AUTOMATIC WHEEL ALIGNMENT

⚠ IMPORTANT ⚠

Check the alignment of the front and rear wheels each time the lift truck is started.

Regularly check the alignment of the wheels when using the lift truck.

The wheels must be aligned and the lift truck must be in front steering wheels mode when used on public roads.

A green light illuminates on the dashboard when the wheels are aligned.

It is not possible to change the steering mode above 11 km/h.

Contact your dealer if you have any questions.



CHANGING THE STEERING MODE



Front steering wheels (road mode).



Front and rear steering wheels in opposite directions (short steering).



Front and rear steering drive wheels in the same direction (crab steering).



Front steering wheels and locking of the rear wheel steering angle.

- Align the rear and front wheels.
- Select the desired steering mode, a flashing indicator lamp will confirm the selection.
- Turn the wheels as instructed on the information screen. The indicator lamp will remain steadily lit while the steering mode is enabled.

26 - DOUBLE-ACTING REAR HYDRAULIC CONTROL PREDISPOSITION

Enables the use of a hydraulic attachment at the rear of the lift truck (e.g. a trailer with hydraulic tipping).

DOUBLE-ACTING REAR HYDRAULIC CONTROL "L3-L4"

- Select the rear attachment hydraulic line .
- Push switch 1 forward or backward.

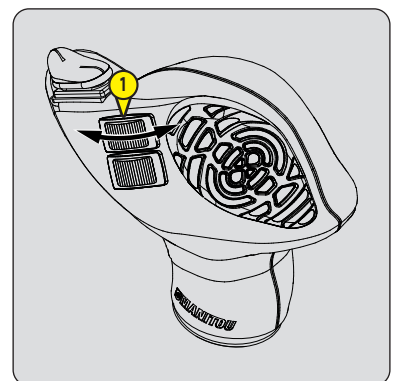
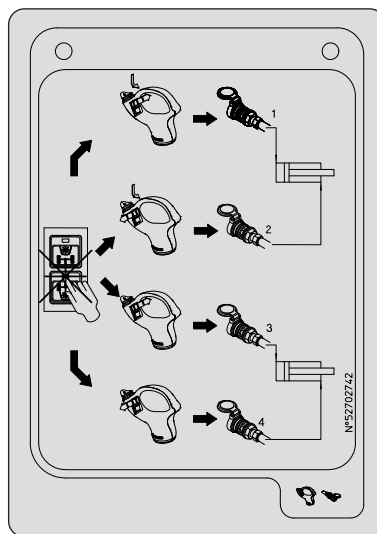

27 - TWO DOUBLE-ACTING REAR HYDRAULIC CONTROL PREDISPOSITIONS

Enables two hydraulic circuits at the rear of the lift truck to be selected for use.

DOUBLE-ACTING REAR HYDRAULIC CONTROL "L3-L4"

- Select the rear attachment hydraulic line 
- Push switch 1 forward or backward.

DOUBLE-ACTING REAR HYDRAULIC CONTROL "L1-L2"

- Select the rear attachment hydraulic line 
- Hold down button 2 and operate button 1 forward or backward.

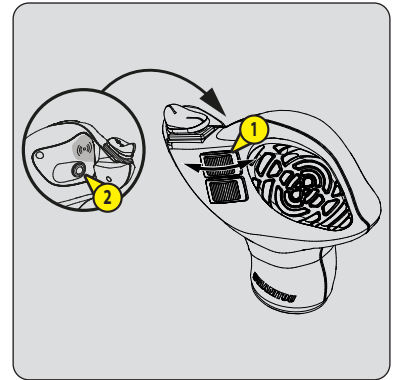
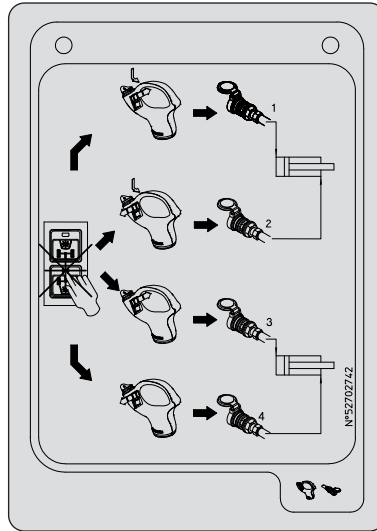

28 - HYDRAULIC TRAILER HOOK + DOUBLE-ACTING REAR HYDRAULIC CONTROL PREDISPOSITION

Enables use of the towing hook () or a hydraulic attachment at the rear of the lift truck.

HYDRAULIC TOWING HOOK "L1-L2"

 TOWING PIN AND HOOK

DOUBLE-ACTING REAR HYDRAULIC CONTROL "L3-L4"

- Select the rear attachment hydraulic line 
- Hold down button 2 and operate button 1 forward or backward.

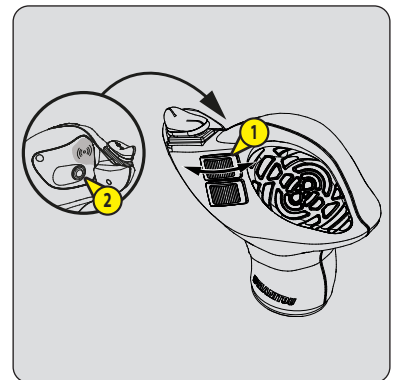
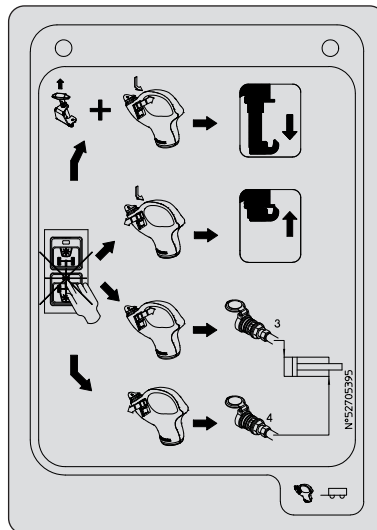
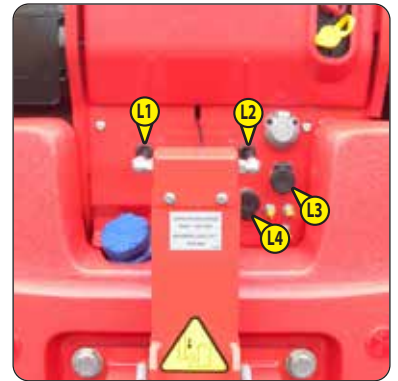

3 - MAINTENANCE

3 - MAINTENANCE

ORIGINAL MANITOU SPARE PARTS AND EQUIPMENT	3-3
FORKLIFT TRUCK MAINTENANCE	3-4
DAILY AND WEEKLY MAINTENANCE	3-4
MANDATORY FIRST 500 HOURS OR 6 MONTHS OF SERVICE	3-5
PERIODIC MAINTENANCE	3-6
OCCASIONAL MAINTENANCE AND OPERATION	3-8
FILTER CARTRIDGES AND BELTS	3-9
LUBRICANTS AND FUEL	3-10
➤ 10H - DAILY SERVICE OR EVERY 10 HOURS OF SERVICE	3-12
➤ 50H - WEEKLY MAINTENANCE OR EVERY 50 HOURS OF SERVICE	3-14
➤ ① 500H - PERIODIC MAINTENANCE - EVERY 500 HOURS OF SERVICE OR 1 YEAR	3-20
➤ ② 1000H - PERIODIC MAINTENANCE - EVERY 1000 HOURS OF SERVICE OR EVERY 2 YEARS	3-26
➤ ③ 2000H - PERIODIC MAINTENANCE - EVERY 2000 HOURS OF SERVICE OR EVERY 4 YEARS	3-32
➤ OCCASIONAL MAINTENANCE	3-36
➤ OCCASIONAL OPERATION	3-40

ORIGINAL MANITOU SPARE PARTS AND EQUIPMENT

OUR LIFT TRUCKS MUST BE SERVICED USING ORIGINAL MANITOU PARTS.

BY ALLOWING THE USE OF NON ORIGINAL MANITOU PARTS, YOU RISK:

⚠ IMPORTANT ⚠

THE USE OF COUNTERFEIT PARTS OR COMPONENTS NOT APPROVED BY THE MANUFACTURER MEANS YOU LOSE THE BENEFIT OF THE CONTRACTUAL GUARANTEE.

- Legally, incurring liability in the event of an accident.
- Technically - to cause operating malfunctions or shorten the life of the lift truck.

BY USING ORIGINAL MANITOU PARTS FOR MAINTENANCE OPERATIONS, YOU BENEFIT FROM OUR KNOW-HOW

Through its network, MANITOU provides the user with,

- Know-how and competence.
- The guarantee of high-quality work.
- Original replacement parts.
- Help with preventive maintenance.
- Efficient help with diagnosis.
- Improvements as a result of feedback.
- Operator training.
- Only the MANITOU network has detailed knowledge of the design of the lift truck and therefore the best technical ability to provide maintenance.

⚠ IMPORTANT ⚠

ORIGINAL REPLACEMENT PARTS ARE DISTRIBUTED EXCLUSIVELY BY MANITOU AND ITS DEALER NETWORK.

The dealer network list is available on the MANITOU web site: www.manitou.com

FORKLIFT TRUCK MAINTENANCE

DAILY AND WEEKLY MAINTENANCE



THE OPERATOR IS AUTHORIZED TO CARRY OUT THIS MAINTENANCE.

These maintenance operations enable the operator to maintain the lift truck in a clean and safe condition.

MANDATORY FIRST 500 HOURS OR 6 MONTHS OF SERVICE



THIS SERVICE MUST BE CARRIED OUT AFTER THE FIRST 500 HOURS OF SERVICE OR WITHIN THE 6 MONTHS FOLLOWING PUTTING THE MACHINE INTO SERVICE (WHICHEVER OCCURS FIRST).

PERIODIC MAINTENANCE



THE PERIODIC MAINTENANCE MUST BE CARRIED OUT BY A PROFESSIONAL APPROVED BY THE MANITOU NETWORK

MAINTENANCE SCHEDULE

This schedule enables the operator to keep up with the periodic maintenance of the lift truck by notifying the total number of hours of operation and the date of the service performed by the professional approved by the MANITOU network.

OCCASIONAL MAINTENANCE AND OPERATION

These maintenance tasks and operations are to be performed as required for the safety and upkeep of the lift truck.

DAILY AND WEEKLY MAINTENANCE

10H - DAILY SERVICE OR EVERY 10 HOURS OF SERVICE

- CHECK	Lift truck environment	3-12
- CHECK	Engine oil level.....	3-12
- CHECK	Coolant level.....	3-12
- CHECK	Fuel pre-filter	3-13
- CHECK	Longitudinal stability limiter and warning device.....	3-13
- CHECK	Greasing unit level (OPTION)	3-13

50H - WEEKLY MAINTENANCE OR EVERY 50 HOURS OF SERVICE

- CHECK	Gearbox oil level	3-14
- CHECK	Angle gear box seal	3-14
- CHECK	Tire pressure.....	3-14
- CHECK	Wheel nut tightening	3-14
- CHECK	Front axle differential seal	3-14
- CHECK	Rear axle differential seal	3-14
- CHECK	Front wheel reducer seals	3-15
- CHECK	Rear wheel reducer seals	3-15
- CHECK	Boom pad slide pathways	3-15
- CHECK	Hydraulic fluid level.....	3-15
- CHECK	Windshield washer fluid level.....	3-16
- CLEAN	Radiator cores	3-16
- CLEAN	Dry air filter cartridge	3-17
- CLEAN	Condenser harness (Air conditioning OPTION)	3-17
- LUBRICATE	General lubrication	3-18
- REPLACE	Angle gear box oil *	3-19

*** Only for the first 50 hours of service and then every 2,000 hours of service or 4 years.**

MANDATORY FIRST 500 HOURS OR 6 MONTHS OF SERVICE

FIRST 500 HOURS BEFORE THE FIRST 6 MONTHS

- If the lift truck has reached the first 500 hours of operation before the first 6 months have expired, perform both the mandatory maintenance and periodic 500 H maintenance (➡ ➡ ➡ 1 500H - PERIODIC MAINTENANCE - EVERY 500 HOURS OF service OR 1 YEAR).

FIRST 6 MONTHS BEFORE THE FIRST 500 HOURS

- If the lift truck has not completed 500 hours of service in the first 6 months, just carry out the mandatory service.

➡ MANDATORY SERVICE

- CHECK	Gearbox oil level	3-14
- CHECK	Angle gear box seal	3-14
- CHECK	Tire pressure	3-14
- CHECK	Wheel nut tightening	3-14
- CHECK	Front axle differential seal	3-14
- CHECK	Rear axle differential seal	3-14
- CHECK	Front wheel reducer seals	3-15
- CHECK	Rear wheel reducer seals	3-15
- CHECK	Boom pad slide pathways	3-15
- CHECK	Hydraulic fluid level	3-15
- CHECK	Windshield washer fluid level	3-16
- CLEAN	Radiator cores	3-16
- CLEAN	Dry air filter cartridge	3-17
- CLEAN	Condenser harness (Air conditioning OPTION)	3-17
- LUBRICATE	General lubrication	3-18
- CHECK	Countdown before "stationary lift truck" exhaust regeneration	3-20
- CHECK	Parking brake	3-20
- CHECK	Fork wear *	3-21
		* Consult your dealer.
- CHECK	Seat belt	3-26
- CHECK	Engine shock mounts *	3-31
- CHECK	Gearbox silent blocks *	3-31
- CHECK	Gearbox controls *	3-31
- CHECK	Brake system pressure *	3-31
- CHECK	Boom pad wear *	3-31
- CHECK	Condition of wiring harnesses and cables *	3-31
- CHECK	Lights and signals *	3-31
- CHECK	Warning indicators *	3-31
- CHECK	Condition of the rear view mirrors *	3-31
- CHECK	Cab structure *	3-31
- CHECK	Chassis structure *	3-31
- CHECK	Attachment mounting system *	3-31
- CHECK	Condition of attachments *	3-31
		* Consult your dealer.

PERIODIC MAINTENANCE

MAINTENANCE SCHEDULE

	↻ OR ↻					
SCHEDULE ↻	FIRST 6 MONTHS	FIRST 500 HOURS	500 H or 1 YEAR	1000 H or 2 YEARS	1500 H or 3 YEARS	2000 H or 4 YEARS
PERIODIC MAINTENANCE ↻	MANDATORY SERVICE	MANDATORY SERVICE + ①	①	①+②	①	①+②+③
MACHINE COUNTER ↻						
DATE OF SERVICING ↻						

SCHEDULE ↻	2500 H or 5 YEARS	3000 H or 6 YEARS	3500 H or 7 YEARS	4000 H or 8 YEARS	4500 H or 9 YEARS	5000 H or 10 YEARS	5500 H or 11 YEARS
PERIODIC MAINTENANCE ↻	①	①+②	①	①+②+③	①	①+②	①
MACHINE COUNTER ↻							
DATE OF SERVICING ↻							

SCHEDULE ↻	6000 H or 12 YEARS	6500 H or 13 YEARS	7000 H or 14 YEARS	7500 H or 15 YEARS	8000 H or 16 YEARS	8500 H or 17 YEARS	9000 H or 18 YEARS
PERIODIC MAINTENANCE ↻	①+②+③	①	①+②	①	①+②+③	①	①+②
MACHINE COUNTER ↻							
DATE OF SERVICING ↻							

↻ ① 500H - PERIODIC MAINTENANCE - EVERY 500 HOURS OF SERVICE OR 1 YEAR

- CHECK	Countdown before "stationary lift truck" exhaust regeneration.....	3-20
- CHECK	Parking brake.....	3-20
- CHECK	Hydraulic oil.....	3-21
- CHECK	Fork wear *.....	3-21
	<i>* Consult your dealer.</i>	
- REPLACE	Engine oil.....	3-22
- REPLACE	Engine oil filter.....	3-22
- REPLACE	Gearbox oil filter.....	3-23
- REPLACE	Front axle differential oil.....	3-23
- REPLACE	Rear axle differential oil.....	3-23
- REPLACE	Hydraulic return oil filter cartridge.....	3-24
- REPLACE	Hydraulic oil tank plug.....	3-24
- REPLACE	Cab ventilation filters.....	3-25
- REPLACE	Filter coupling (OPTIONAL Automatic central greasing).....	3-25

➔ 2 1000H - PERIODIC MAINTENANCE - EVERY 1000 HOURS OF SERVICE OR EVERY 2 YEARS

ALSO CARRY OUT THE PERIODIC MAINTENANCE FOR 500 HOURS OF SERVICE.

- CHECK	Seat belt	3-26
- CLEAN	Fuel tank	3-26
- REPLACE	Fuel tank breather	3-26
- REPLACE	Coolant	3-27
- REPLACE	Dry air filter cartridge	3-27
- REPLACE	Fuel pre-filter	3-28
- REPLACE	Fuel filter	3-28
- REPLACE	"DEF" (Diesel Exhaust Fluid) supply pump filter	3-29
- REPLACE	Tank filling strainer "DEF" (diesel exhaust fluid)	3-29
- REPLACE	Gearbox oil	3-30
- CLEAN	Gearbox sump strainer	3-30
- REPLACE	Front wheel reducer oil	3-30
- REPLACE	Rear wheel reducer oil	3-30
- CHECK	Engine shock mounts *	3-31
- CHECK	Gearbox silent blocks *	3-31
- CHECK	Gearbox controls *	3-31
- CHECK	Brake system pressure *	3-31
- CHECK	Boom pad wear *	3-31
- CHECK	Condition of wiring harnesses and cables *	3-31
- CHECK	Lights and signals *	3-31
- CHECK	Warning indicators *	3-31
- CHECK	Condition of the rear view mirrors *	3-31
- CHECK	Cab structure *	3-31
- CHECK	Chassis structure *	3-31
- CHECK	Attachment mounting system *	3-31
- CHECK	Condition of attachments *	3-31

** Consult your dealer.*

➔ 3 2000H - PERIODIC MAINTENANCE - EVERY 2000 HOURS OF SERVICE OR EVERY 4 YEARS

ALSO PERFORM THE 500 HOUR AND 1000 HOUR PERIODIC MAINTENANCE.

- CHECK	Wheel nut tightening torque	3-32
- CLEAN	Air conditioning (OPTION) *	3-32
		<i>* Consult your dealer.</i>
- REPLACE	Dry air filter safety cartridge	3-32
- REPLACE	Alternator belt	3-33
- REPLACE	Angle gear box oil	3-33
- REPLACE	Hydraulic oil	3-34
- CLEAN	Hydraulic oil tank suction strainer	3-34
- REPLACE	Ventilation reversal filter	3-34
- CHECK	Radiator *	3-35
- CHECK	Transmission pressures *	3-35
- CHECK	Steering *	3-35
- CHECK	Steering swivel joints *	3-35
- CHECK	Condition of boom assembly *	3-35
- CHECK	Bearings and bushings of the boom *	3-35
- CHECK	Condition of hoses and flexible pipes *	3-35
- CHECK	Condition of cylinders (leakage, rods) *	3-35
- CHECK	Hydraulic circuit pressures *	3-35
- CHECK	Chassis bearings and bushings*	3-35
- REPLACE	Compressor belt (Air Conditioning OPTION) *	3-35

** Consult your dealer.*

OCCASIONAL MAINTENANCE AND OPERATION

↻ OCCASIONAL MAINTENANCE

- CLEAN	Lift truck	3-36
- CLEAN	"Stationary lift truck" exhaust regeneration	3-36
- REPLACE	Wheels	3-37
- REPLACE	Battery	3-38
- ADJUST	Front headlights	3-38
- RESET	Longitudinal stability limiter and warning device	3-39

↻ OCCASIONAL OPERATION

- TOW OR WINCH	Lift truck	3-40
- SLING	Lift truck	3-40
- TRANSPORT	Lift truck	3-41

FILTER CARTRIDGES AND BELTS

➔ ① 500H - PERIODIC MAINTENANCE - EVERY 500 HOURS OF SERVICE OR 1 YEAR



ENGINE OIL FILTER

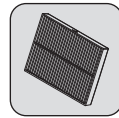

EXTERIOR CAB VENTILATION FILTER

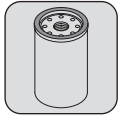

GEARBOX OIL FILTER

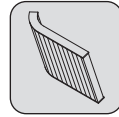

INTERIOR CAB VENTILATION FILTER

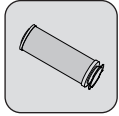

HYDRAULIC RETURN OIL FILTER CARTRIDGE



FILTER COUPLING
(AUTOMATIC CENTRAL GREASING OPTION)

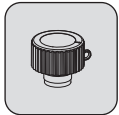

HYDRAULIC OIL TANK PLUG

➔ ② 1000H - PERIODIC MAINTENANCE - EVERY 1000 HOURS OF SERVICE OR EVERY 2 YEARS

ALSO ADD THE FILTER CARTRIDGES FROM THE PERIODIC MAINTENANCE FOR 500 HOURS OF SERVICE.



DRY AIR FILTER CARTRIDGE

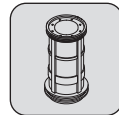

"DEF"(Diesel Exhaust Fluid) FEED PUMP FILTER

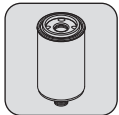

FUEL PRE-FILTER



TANK FILLING STRAINER "DEF" (diesel exhaust fluid)

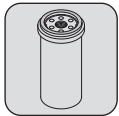

FUEL FILTER



FUEL TANK BREATHER

➔ ③ 2000H - PERIODIC MAINTENANCE - EVERY 2000 HOURS OF SERVICE OR EVERY 4 YEARS

ALSO ADD FILTER ELEMENTS FOR PERIODIC MAINTENANCE AT 500 HOURS AND 1,000 HOURS OF SERVICE.

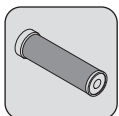

SAFETY DRY AIR FILTER CARTRIDGE



ALTERNATOR BELT

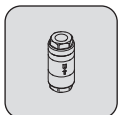

FAN REVERSAL



ALTERNATOR BELT
(PNEUMATIC TRAILER BRAKE OPTION)

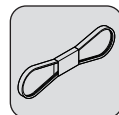

COMPRESSOR BELT
(AIR CONDITIONING OPTION)

➔ OCCASIONAL MAINTENANCE

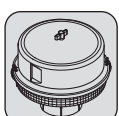

SELF-CLEANING PRE-FILTER

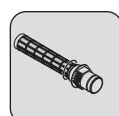

SUCTION STRAINER FOR HYDRAULIC OIL TANK

LUBRICANTS AND FUEL

⚠ IMPORTANT ⚠

USE THE RECOMMENDED LUBRICANTS AND FUEL:

- For topping up, oils may not be miscible.
- For oil changes, MANITOU oils are perfectly appropriate.

DIAGNOSTIC ANALYSIS OF OILS

If a service or maintenance contract has been set up with the dealer, a diagnostic analysis of engine, transmission and axle oils may be requested depending on the rate of use.

(*) REQUIRED FUEL SPECIFICATION

Use a high-quality fuel to obtain optimal performance of the engine.

- EN590 diesel fuel (sulphur content < 10 ppm)
- ASTM D975 diesel fuel (sulphur content < 15 ppm)

(**) SPECIFICATION "DEF" (Diesel Exhaust Fluid)

- Aqueous urea solution at 32.5% (ISO22241)
- Solidification at -11 °C and 10% expansion
- Non-flammable product
- Thermal degradation (>60 °C)
- Storage between -5 °C and 30 °C

⚠ IMPORTANT ⚠

Corrosive to metals, requires wearing personal protection (gloves and goggles).

RECOMMENDATION

ENGINE			RECOMMENDATION										
PARTS TO BE LUBRICATED	CAPACITY		-40 °C	-30	-20	-10	0	+10	+20	+30	+40	+50 °C	
ENGINE	9 ℓ						0W30						
							0W40						
							5W30						
							5W40						
							10W30						
							MANITOU EVOLVOY OIL 10W40 API CJ4						
							15W40						
							20W50						
COOLING CIRCUIT	13,7 ℓ						COOLANT -35 °C						
FUEL TANK	78 ℓ												
ADDITIONAL FUEL TANK (OPTION)	42 ℓ						HP NON-ROAD DIESEL (GNR) *						
TANK "DEF" (Diesel Exhaust Fluid)	13 ℓ						DEF **						
TRANSMISSION			RECOMMENDATION										
DESCRIPTION	CAPACITY		-40 °C	-30	-20	-10	0	+10	+20	+30	+40	+50 °C	
GEARBOX	16 ℓ						MANITOU DX IIIG AUTOMATIC TRANSMISSION OIL						
ANGLE GEARBOX	1,5 ℓ						MANITOU GERION TDL 75W90 OIL						

FRONT AXLE											
PARTS TO BE LUBRICATED	CAPACITY	RECOMMENDATION									
FRONT AXLE DIFFERENTIAL	7,3 ℓ	SPECIAL MANITOU OIL FOR IMMersed BRAKES									
		-40 °C	-30	-20	-10	0	+10	+20	+30	+40	+50 °C
FRONT WHEEL REDUCING GEAR	2 x 0,8 ℓ	MANITOU SAE80W90 MECHANICAL TRANSMISSION OIL									
		-40 °C	-30	-20	-10	0	+10	+20	+30	+40	+50 °C
FRONT WHEEL REDUCING GEAR PIVOTS		MANITOU BLACK MULTI-PURPOSE LUBRICANT									

REAR AXLE											
PARTS TO BE LUBRICATED	CAPACITY	RECOMMENDATION									
REAR AXLE DIFFERENTIAL	7,3 ℓ	SPECIAL MANITOU OIL FOR IMMersed BRAKES									
		-40 °C	-30	-20	-10	0	+10	+20	+30	+40	+50 °C
REAR WHEEL REDUCING GEAR	2 x 0,8 ℓ	MANITOU SAE80W90 MECHANICAL TRANSMISSION OIL									
		-40 °C	-30	-20	-10	0	+10	+20	+30	+40	+50 °C
REAR WHEEL REDUCING GEAR PIVOTS		MANITOU BLACK MULTI-PURPOSE LUBRICANT									
		-40 °C	-30	-20	-10	0	+10	+20	+30	+40	+50 °C
REAR AXLE OSCILLATION		MANITOU BLUE MULTI-PURPOSE LUBRICANT									

BOOM											
PARTS TO BE LUBRICATED	CAPACITY	RECOMMENDATION									
		-40 °C	-30	-20	-10	0	+10	+20	+30	+40	+50 °C
BOOM PAD SLIDE PATHWAYS		MANITOU BLACK MULTI-PURPOSE LUBRICANT									
		-40 °C	-30	-20	-10	0	+10	+20	+30	+40	+50 °C
GREASING OF THE BOOM		MANITOU BLUE MULTI-PURPOSE LUBRICANT									

HYDRAULIC											
PARTS TO BE LUBRICATED	CAPACITY	RECOMMENDATION									
		-40 °C	-30	-20	-10	0	+10	+20	+30	+40	+50 °C
HYDRAULIC OIL TANK	81 ℓ							ISO VG 100			
								ISO VG 68			
								MANITOU ISO VG 46 HYDRAULIC FLUID			
								ISO VG 37			
								ISO VG 32			

CAB											
PARTS TO BE LUBRICATED	CAPACITY	RECOMMENDATION									
		-40 °C	-30	-20	-10	0	+10	+20	+30	+40	+50 °C
CAB DOOR		MANITOU BLUE MULTI-PURPOSE LUBRICANT									
WINDSHIELD WASHER TANK	2 ℓ	WINDSHIELD WASHER FLUID									
COMPRESSOR (AIR CONDITIONING OPTION)	0.24 ℓ	R12 MINERAL OIL									

AUTOMATIC CENTRAL GREASING (OPTION)											
DESCRIPTION	CAPACITY	RECOMMENDATION									
		-40 °C	-30	-20	-10	0	+10	+20	+30	+40	+50 °C
GREASING UNIT TANK	3 ℓ	MANITOU BLUE MULTI-PURPOSE LUBRICANT									

CHECK

Lift truck environment

Carry out a general inspection around the lift truck:

- Fluid leaks or stains on the ground.
- Additional objects on the lift truck and in the cab.
- Mounting and locking of the attachment.
- Mounting and adjustment of rear-view mirrors.
- Condition of the tires, to detect cuts, blisters, wear, etc.

⚠ IMPORTANT ⚠

Follow the operator instructions (↩ 1 - OPERATING AND SAFETY INSTRUCTIONS: OPERATOR INSTRUCTIONS).

CLEANLINESS OF THE FORKLIFT

- Cleanliness of lights and rear-view mirror.
- Excess dirt or build-up of material (e.g. straw, flour, sawdust, organic waste, etc.).
- On a daily basis, according to the conditions of use and the environment, the operator should ensure that the forklift truck is kept in a clean condition.
- Particular attention should be paid to accumulations of flammable materials (e.g. straw, flour, sawdust, organic waste, etc.) and fuel or lubricant leaks, as these significantly increase the risk of fire outbreaks.
- A regular inspection of the whole lift truck, especially the engine housing and the central part of the chassis, is necessary to see how frequently it needs to be cleaned to prevent these potential accumulations of material or leakages.

CHECK

Engine oil level

Place the lift truck on level ground with the engine stopped, and let the oil settle in the sump.

- Open the engine hood.
- Pull out the dipstick 1.
- Clean the dipstick and check the correct level between the two notches.
- If necessary, add oil (↩ LUBRICANTS AND FUEL) through the filler hole 2.
- Visually check that there is no leakage or seepage.



CHECK

Coolant level

Place the lift truck on level ground with the engine stopped, and allow the engine to cool.

⚠ IMPORTANT ⚠

To avoid any risk of spraying or scalding, wait until the engine has cooled down before removing the cooling circuit filler plug.

In the event of an emergency, it is possible to use water as the coolant, but then proceed to drain the coolant circuit as quickly as possible.

- Open the engine hood.
- The liquid must be at the MAX. level on the expansion tank 1.
- If necessary, add coolant (↩ LUBRICANTS AND FUEL) through the filler hole 2.
- Visually check that there is no leakage or seepage.



CHECK

Fuel pre-filter

⚠ IMPORTANT ⚠

Carefully clean the outside of the pre-filter and its holder, to prevent dust from getting into the system.

- Open the engine hood.
- Disconnect electrical wiring harness 1 from the fuel pre-filter.
- Place a hose on the drain plug 2 and the other end in a container.
- Unscrew the drain plug 2 by two turns.
- Allow the diesel fuel to flow out until it is free from impurities and water.
- Retighten drain plug 2 and reconnect the wiring harness 1.



CHECK

Longitudinal stability limiter and warning device

Place the lift truck on flat, level ground with the wheels straight.

- Press button B to display the "PREFERENCE" menu
- Turn knob A to navigate through the menus and sub-menus.

HYDRAULIC	>	STABILITY TEST
-----------	---	----------------

- Press knob A to confirm.
- Follow the steps described on the information screen (OK = press button A).

⚠ IMPORTANT ⚠

If an error code is displayed, recalibrating the longitudinal stability limiter and warning device may resolve the problem (⚡ OCCASIONAL MAINTENANCE).



CHECK

Greasing unit level (OPTION)

Check the following points of the greasing system:

- The grease level in the greasing unit tank.
- The condition of the greasing unit (damage and leaks).
- No damage or leaks on the primary and secondary lines.
- There must be a collar of fresh grease on all of the greasing points.

The greasing unit is equipped with a filter coupling 1 on which a grease pump can be installed.

- Top up with the recommended grease as required (⚡ LUBRICANTS AND FUEL).

FILLING PROCEDURE:

- Carefully clean the filter coupling 1 and your filling system.
- Connect your filling system to the filter coupling.
- Fill the tank to its maximum level as indicated on the tank.

⚠ IMPORTANT ⚠

*Never fill the tank higher than the maximum level indicated, as this may damage the system.
If filling is difficult, check the condition of the filter coupling and replace it.*

- Remove your filling system.
- Clean the filter coupling before putting it back.



➔ 50H - WEEKLY MAINTENANCE OR EVERY 50 HOURS OF SERVICE

CHECK

Gearbox oil level

Park the lift truck on level ground with the boom raised and the engine stopped. Carry out the check within 5 minutes of the engine being stopped.

⚠ IMPORTANT ⚠

Raise the boom and place the boom safety wedge on the rod of the lifting cylinder (↖ 1 - INSTRUCTIONS AND SAFETY RECOMMENDATIONS: LIFT TRUCK MAINTENANCE INSTRUCTIONS).

- Remove the plastic cap 1.
- Pull out the dipstick 2.
- Wipe the dipstick and check the correct level between the two MIN and MAX marks.
- If necessary, add oil (↖ 1000H: REPLACE Gearbox oil).
- Visually check that there is no leakage or seepage.

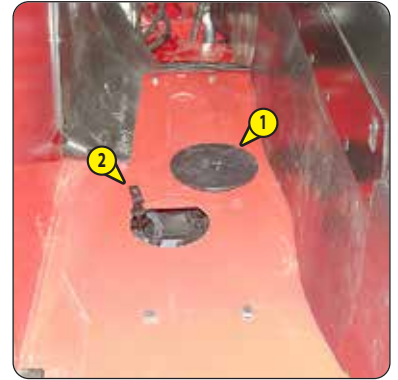

CHECK

Angle gear box seal

Place the lift truck on level ground with the engine stopped.

- Visually check that there is no leakage or seepage.
- If there is any leakage or seepage, check the level:
 - Remove the level plug 1, the oil should be flush with the edge of the hole.
 - If necessary, add oil (↖ LUBRICANTS AND FUEL) through the same hole.
 - Refit and tighten the level plug 1 (tightening torque 25 - 35 N.m).



CHECK

Tire pressure

CHECK

Wheel nut tightening

⚠ IMPORTANT ⚠

Check that the air hose is correctly connected to the tire valve before inflating and keep all persons at a distance during inflation. Inflate to the recommended tire pressures.

- Check the wheel nut torque. Non-compliance with this instruction can lead to deterioration and breakage of the wheel lugs and distortion of the wheels.
 - Check and restore tire pressure, if necessary (↖ 2 - DESCRIPTION: TIRES).
- N.B.: An OPTIONAL wheel tool kit is available.

CHECK

Front axle differential seal

CHECK

Rear axle differential seal

Place the lift truck on level ground with the engine stopped.

- Visually check that there is no leakage or seepage.
- If there is any leakage or seepage, check the level:
 - Remove the level plug 1, the oil should be flush with the edge of the hole.
 - If necessary, add oil (↖ LUBRICANTS AND FUEL) through the filler hole 2.
 - Refit and tighten the level plug 1 (tightening torque 34 - 49 N.m).

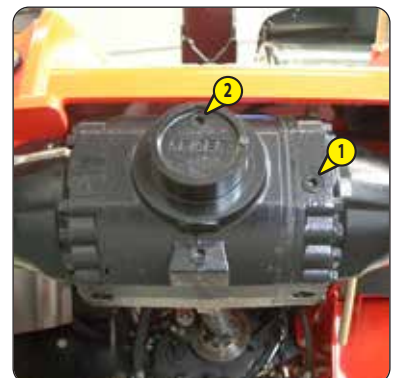

CHECK

Front wheel reducer seals

CHECK

Rear wheel reducer seals

Place the lift truck on level ground with the engine stopped.

- Visually check that there is no leakage or seepage.
- If there is any leakage or seepage, check the level:
 - Place level plug 1 in a horizontal position.
 - Remove the level plug; the oil should be flush with the edge of the opening.
 - If necessary, add oil (↖ LUBRICANTS AND FUEL) through the same hole.
 - Refit and tighten the level plug (tightening torque 34 - 49 N.m).



CHECK

Boom pad slide pathways

To preserve optimum operation, the pad slide pathways should be correctly lubricated:

⚠ IMPORTANT ⚠

MANDATORY GREASING OF THE BOOM AFTER:

Cleaning the boom, especially after using high pressure cleaner.

The forklift has been unused for a long period of time.

- Fully extend the boom.
- Check the condition of the surface of the pad slide pathways, surface run in (steel whitened) without traces of corrosion.
- If necessary lubricate the pad slide pathways (↖ LUBRICANTS AND FUEL).
- Telescope the boom several times in order to spread the coat of grease evenly.
- Remove the surplus of grease.



⚠ IMPORTANT ⚠

If the lift truck is used in an abrasive environment (dust, sand, coal) use lubricating varnish (MANITOU Part No.: 483536). Consult your dealer.

CHECK

Hydraulic fluid level

Place the lift truck on level ground with the engine stopped, and the boom retracted and lowered as far as possible.

⚠ IMPORTANT ⚠

Use a very clean funnel and clean the top of the oil can before filling.

- Check dipstick 1, the correct level should be at the maximum level.
- If necessary, add oil (↖ LUBRICANTS AND FUEL).
- Visually check that there is no leakage or seepage.
- Remove the cap 2.
- Add oil through filler port 3.
- Refit the cap.



CHECK

Windshield washer fluid level

- Open the protective casing 1 with the ignition key.
- Visually check the level in tank 2.
- If necessary, add windshield washer fluid (↩ LUBRICANTS AND FUEL).
- Remove the cap 3.
- Add windshield washer liquid through filler port.
- Refit the cap.



CLEAN

Radiator cores

⚠ IMPORTANT ⚠

In a polluting atmosphere, clean the radiator cores every day. Do not use a water jet or high pressure steam as this could damage the fins.

- Open the engine hood.
- If necessary, clean the intake grille on the engine cover.
- Using a soft cloth, clean the radiator cores in order to remove as much dirt as possible.
- Clean the radiator using a compressed air jet aimed from the engine toward the radiator, in the opposite direction to the cooling air flow.
- Using the handle 1, open the access panel 2 to remove impurities.



Prefiltration elements are available for use in very dusty conditions (< FILTER CARTRIDGES AND BELTS). The cartridge checking and cleaning interval must also be reduced.

⚠ IMPORTANT ⚠

If the clogging indicator lamp comes on, this operation should be performed as soon as possible (maximum 1 hour). Never operate the lift truck without an air filter or with an air filter that is damaged.

Maintain a safety distance of 30 mm between the jet of air and the cartridge to avoid tearing or piercing the cartridge. The cartridge must not be blown through close to the air filter casing. Never clean the cartridge by tapping it on a hard surface. Protect your eyes during this operation.

Do not clean the dry air filter cartridge by washing it in liquid. Never clean the safety cartridge located inside the filter cartridge. Change it for a new one if it is clogged or damaged.

- For the dismantling and refitting of the cartridge (< 1000H: REPLACE Air filter cartridge).
- Clean the filter cartridge using a compressed air jet (max. pressure 3 bars) directed from the top to the bottom and from the inside toward the outside at a minimum distance of 30 mm from the cartridge wall.
- Cleaning is completed when there is no more dust on the cartridge.
- Clean the cartridge seal surface with a damp, clean lint-free cloth and grease with a silicone lubricant (MANITOU part no.: 479292).
- Visually inspect the external condition of the air filter and its mounts. Check also the condition of the hoses and their attachments.

⚠ IMPORTANT ⚠

In a polluting atmosphere, clean the radiator harness daily. Do not use a water jet or high-pressure steam as this could damage the condenser fins.

- Remove the protective grid 1 and clean it if necessary.
- Visually check whether the condenser is clean and clean it if necessary.
- Clean the condenser using a compressed air jet aimed in the same direction as the air flow.
- Clean with the fans running for best results.



To be carried out weekly, if the lift truck has been operated for less than 50 hours during the week.

⚠ IMPORTANT ⚠

In the event of prolonged use in an extremely dusty or oxidizing atmosphere, reduce this interval to 10 hours of service or every day.

Clean, then lubricate the following points with grease (← LUBRICANTS AND FUEL) and remove the surplus.

BOOM

- 1 - Lubricators of the boom pin (2 lubricators).
- 2 - Lubricators of the carriage pin (2 lubricators).
- 3 - Lubricator of the tilting cylinder foot pin (1 lubricator).
- 4 - Lubricator of the tilting cylinder head pin (1 lubricator).
- 5 - Lubricators of the carriage connecting rod pins (3 lubricators).
- 6 - Lubricator of the lifting cylinder foot pin (1 lubricator).
- 7 - Lubricator of the lifting cylinder head pin (1 lubricator).
- 8 - Lubricator of the compensating cylinder foot pin (1 lubricator).
- 9 - Lubricator of the compensating cylinder head pin (1 lubricator).

FRONT AND REAR WHEEL REDUCTION GEAR PIVOTS

- 10 - Lubricators of the wheel reduction gear pivot pins (8 lubricators).

REAR AXLE OSCILLATION

- 11 - Rear axle oscillation lubricators (2 lubricators).

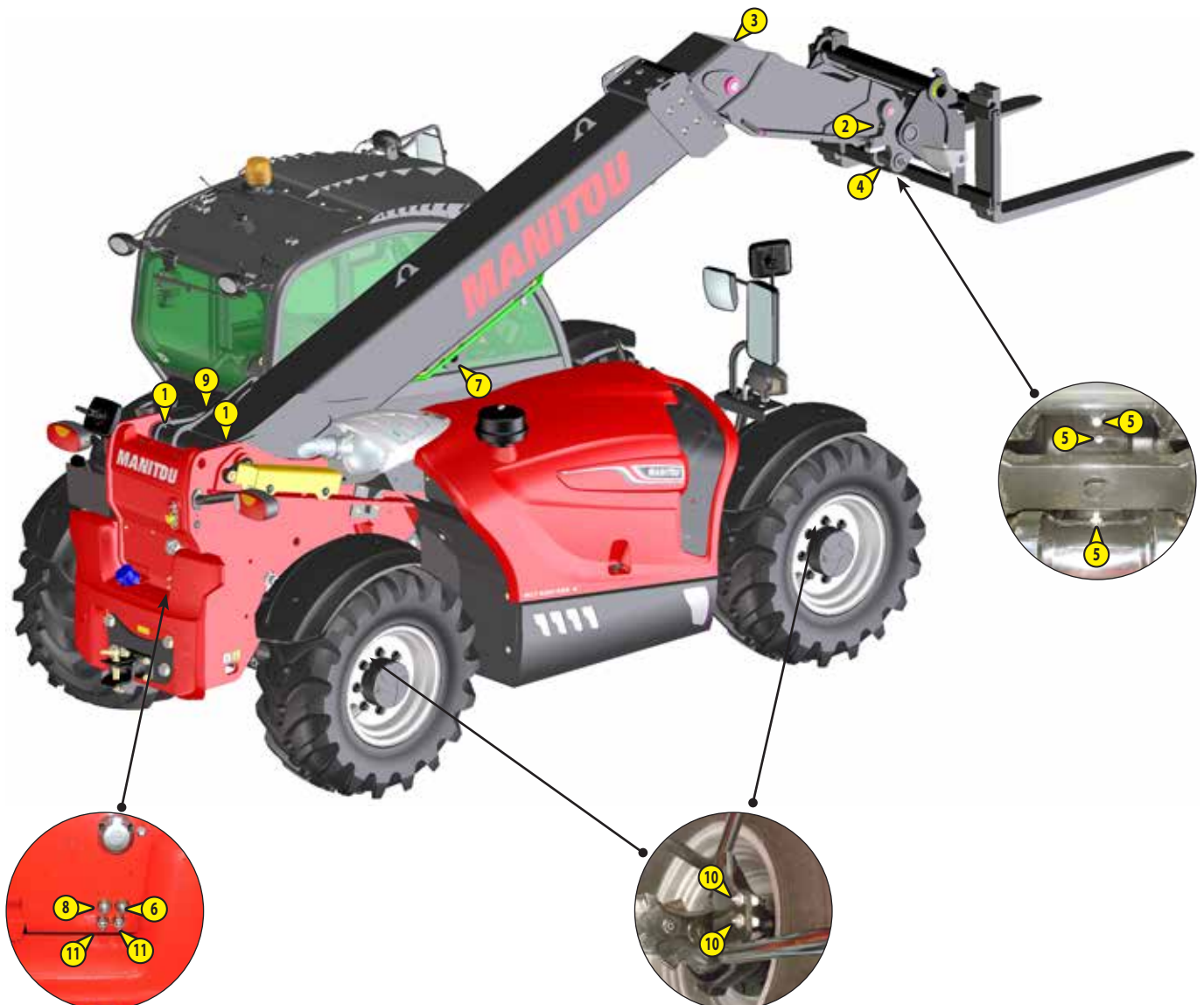

REPLACE

Angle gear box oil *

Place the lift truck on level ground with the engine stopped.

- Place a container under drain plug 1 and unscrew the plug.
- Remove level and filling plug 2 to ensure correct drainage.
- Refit and tighten the drain plug 1 (tightening torque 25 - 35 N.m).
- Fill up with oil (↙ LUBRICANTS AND FUEL) through filler hole 2.
- The level is correct when the oil level is flush with the edge of opening 2.
- Check for any possible leaks at the drain plug.
- Refit and tighten the level and filling plug 1 (tightening torque 25 - 35 N.m).

** Only for the first 50 hours of service and then every 2,000 hours of service or 4 years.*

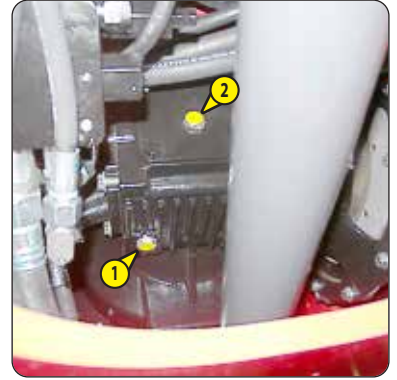

➔ 500H - PERIODIC MAINTENANCE - EVERY 500 HOURS OF SERVICE OR 1 YEAR

CHECK Countdown before "stationary lift truck" exhaust regeneration

Depending on the countdown before the next regeneration, you can evaluate and, if necessary, perform a regeneration during the periodic 500-hour service (➔ 3 - MAINTENANCE: OCCASIONAL MAINTENANCE).

- Press button B to display the "PREFERENCES" menu.
- Turn knob A to navigate through the menus and sub-menus.

ENGINE	>	REGENERATION
--------	---	--------------

- Press button A to display the countdown before next regeneration screen (700h => 0h).



CHECK

Parking brake

⚠ IMPORTANT ⚠

The manufacturer's stop settings must not be changed under any circumstances.

BRAKE SYSTEM CHECK

Place the lift truck on level ground with the engine stopped.

- Remove the cover plate 1.
- N.B.: When removing cover plates and hatches, clean the surrounding area and remove any accumulations of flammable materials.
- If necessary, correctly clean the environment of the connecting rods and setting stops.
- Release then apply the parking brake several times, checking that the connecting rods 2 return to the stops 3.
- In the event of a malfunction, contact your dealer.



BRAKE CHECK

Place the lift truck on a slope of 15% with the rated load in the transport position.

- Immobilize the lift truck using the service brake pedal.
- Firmly apply the parking brake in position A.
- Release the service brake pedal.
- Braking is working correctly if the lift truck remains stationary on the slope.
- In the event of poor braking, contact your dealer.

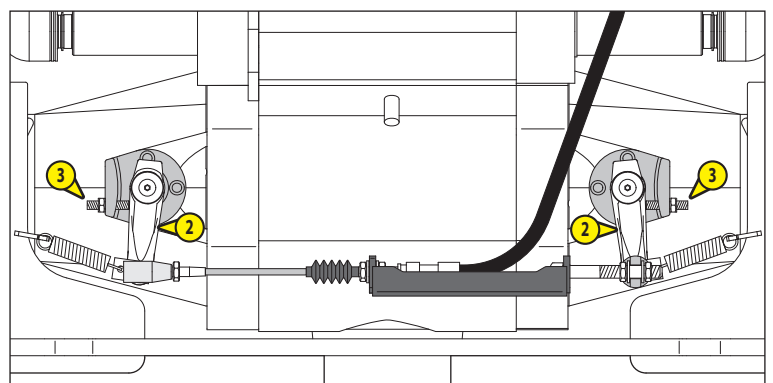

CHECK

Hydraulic oil

MANITOU offers a hydraulic fluid analysis kit which might make it possible to delay the recommended deadline in the periodic maintenance schedule (2,000 hours). In this case, we recommend an analysis of the hydraulic oil every 500 hours of service.

The oil analysis kit also makes it possible to confirm the oil quality so as to obtain a deadline of 2,000 hours for specific uses causing constraints on the hydraulic circuit: extreme environmental conditions, use of the attachments with a very high hydraulic flow rate (such as a sweeper, or a concrete mixer).

- Order an oil analysis kit from your dealer.
- Upon receiving the kit, take a sample of oil and follow the instructions shown on the kit.
- According to the results, keep the analysis report or replace the hydraulic fluid.

Oil analysis kit (MANITOU Part No.: 958162)



CHECK

Fork wear*

**** Consult your dealer.***

REPLACE

Engine oil

REPLACE

Engine oil filter

Place the lift truck on level ground, let the engine run at idle for a few minutes, then stop the engine.

⚠ IMPORTANT ⚠

*Dispose of the used oil in an ecological manner.
Hand-tighten the oil filter and lock in place with a quarter turn.*

DRAINING THE OIL

- Open the engine hood.
- Remove access panel 1.

N.B.: When removing cover plates and hatches, clean the surrounding area and remove any accumulations of flammable materials.

- Place a container under the drain hole and unscrew the drain plug 2.
- Take drain hose 3.
- Place the end of the drain hose in the container and screw the hose fully to the drain connector 2.
- Remove the filler plug 4 to ensure correct drainage.

REPLACEMENT OF THE FILTER

- Unscrew and discard the engine oil filter 5, together with its seal.
- Clean the filter bracket with a clean, lint-free cloth.
- Lightly oil the seal before refitting the new oil filter (⚡ FILTER CARTRIDGES AND BELTS) on its bracket (tightening torque 15 - 17 N.m).

FILLING WITH OIL

- Remove, clean and refit drain hose 3.
- Refit and tighten the drain plug 2.
- Fill up with oil (⚡ LUBRICANTS AND FUEL) through filler hole 4.
- Wait a few minutes to allow the oil to flow into the sump.
- Start the engine and let it run for a few minutes.
- Check for possible leaks from the drain plug and the oil filter.
- Stop the engine, wait a few minutes and check the correct level between the two marks on the dipstick 6.
- Top up the level, if necessary.
- Refit the access cover 1.



REPLACE

Gearbox oil filter

⚠ IMPORTANT ⚠

Raise the boom and place the boom safety wedge on the rod of the lifting cylinder (↖ 1 - INSTRUCTIONS AND SAFETY RECOMMENDATIONS: LIFT TRUCK MAINTENANCE INSTRUCTIONS).

Tighten the gearbox oil filter by hand only and lock the filter in place by a quarter turn.

- Remove the cover plate 1.
- N.B.: When removing cover plates and hatches, clean the surrounding area and remove any accumulations of flammable materials.
- Unscrew and discard gearbox oil filter 2.
- Carefully clean the filter head with a clean, lint-free cloth.
- Lightly oil the new seal and fit it to the filter.
- Fill up the new gearbox oil filter (↖ FILTER CARTRIDGES AND BELTS) with oil (↖ LUBRICANTS AND FUEL).
- Refit the filter, making sure that the seal is correctly positioned and tightened.
- Refit cover plate 1.



REPLACE

Front axle differential oil

REPLACE

Rear axle differential oil

Place the lift truck on level ground with the engine stopped and the still warm differential oil.

⚠ IMPORTANT ⚠

Dispose of the used oil in an ecological manner.

- Place a container under drain plugs 1 and unscrew them.
- Remove level plug 2 and filling plug 3 to ensure that the oil is drained properly.
- Refit and tighten the drain plugs 1 (tightening torque 34 - 49 N.m).
- Fill up with oil (↖ LUBRICANTS AND FUEL) through filler hole 3.
- The level is correct when the oil level is flush with the edge of opening 2.
- Check for any possible leaks at the drain plugs.
- Refit and tighten level plug 2 (tightening torque 34 - 49 N.m) and filling plug 3 (tightening torque 34 - 49 N.m).
- Repeat this operation for the rear axle differential.

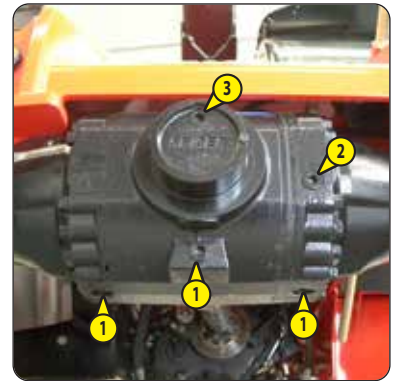

REPLACE

Hydraulic return oil filter cartridge

REPLACE

Hydraulic oil tank plug

Stop the engine and release the pressure from the systems by operating the hydraulic controls.

⚠ IMPORTANT ⚠

Thoroughly clean the outside of the filter and its surroundings before any operation to prevent any risk of polluting the hydraulic system.

Tighten the body of the filter by hand pressure only and lock the body of the filter in place by a quarter turn.

- Place a container under hydraulic return oil filter 1.
- Unscrew the filter cover 2 by two or three thread turns.
- Wait a few moments while the oil flows into the container.
- Remove the cover and slowly take out the filter cartridge assembly.
- Place the assembly in a clean container.
- Separate the head 3 from the tank 4.
- Replace the cartridge 5 with a new one (↩ FILTER CARTRIDGES AND BELTS).
- Make sure that the cartridge is correctly positioned.
- Refit the head 3 on the tank 4.
- Refit the assembly and screw the filter cover 2 back on.
- Replace the filler plug 6 with a new one (↩ FILTER CARTRIDGES AND BELTS).

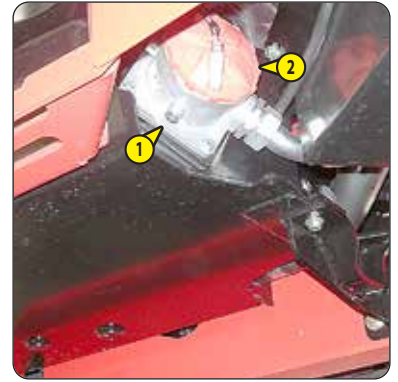

REPLACE

Cab ventilation filters

EXTERNAL CAB VENTILATION FILTER

- Remove protective casing 1 using the ignition key.
- Remove the cab ventilation filter 2 and replace it with a new one (↩ FILTER CARTRIDGES AND BELTS).
- Refit the protective casing.



INTERNAL CAB VENTILATION FILTER

- Remove the protective grid 3.
- Remove the cab ventilation filter 4 and replace it with a new one (↩ FILTER CARTRIDGES AND BELTS).
- Refit the protective grid.



REPLACE

Filter coupling (OPTIONAL Automatic central greasing)

- Switch off the lift truck's ignition.
- Remove the filter coupling 1 from the greasing unit.
- Clean the hole in the unit with a clean rag.
- Fit the new filter coupling to the unit (↩ FILTER CARTRIDGES AND BELTS).
- Top up with grease if required.



🔄 1000H - PERIODIC MAINTENANCE - EVERY 1000 HOURS OF SERVICE OR EVERY 2 YEARS

ALSO CARRY OUT THE PERIODIC MAINTENANCE FOR 500 HOURS OF SERVICE.

CHECK

Seat belt

⚠️ IMPORTANT ⚠️

*Under no circumstances must the lift truck be used if the seat belt is defective (fixing, locking, cuts, tears, etc.).
Immediately repair or replace the seat belt.*

SEAT BELT WITH TWO ANCHORING POINTS

- Check the following points:
 - Fixing of the anchoring points on the seat.
 - Cleanness of the strap and the locking mechanism.
 - Triggering of the locking mechanism.
 - Condition of the strap (cuts, curled edges).

REELED SEAT BELT WITH TWO ANCHORING POINTS

- Check the points listed above together with the following points:
 - The correct winding of the belt.
 - Condition of the reel guards.
 - Roller locking mechanism when the strap is given a sharp tug.

N.B.: Replace the seat belt after an accident.

CLEAN

Fuel tank

REPLACE

Fuel tank breather

Place the lift truck on level ground with the engine stopped.

⚠️ IMPORTANT ⚠️

Do not smoke or approach with a flame during this operation.

Never attempt to carry out welding or any other operation by yourself, as this could cause an explosion or a fire.

- Inspect the parts of the fuel circuit and the tank liable to leak, both visually and by touch.
- In the event of a leak, contact your dealer.
- Place a container under drain plug 1 and unscrew the plug.
- Remove the filler plug 2 to ensure correct drainage.
- Rinse with ten liters of clean diesel through the filler hole 3.
- Refit and tighten the drain plug 1 (tightening torque 29 - 39 N.m).
- Unscrew the breather 4 and replace with a new one (⇐ FILTER CARTRIDGES AND BELTS) (tightening torque 5 ± 2 N.m).
- Fill the fuel tank with clean diesel filtered through the filler port.
- Refit the filler plug.



REPLACE

Coolant

These operations are to be carried out as necessary or every 2 years at the beginning of winter. Place the lift truck on level ground with the engine stopped and cold.

⚠ IMPORTANT ⚠

The engine does not contain any anti-corrosion elements and must be filled throughout the year with a mixture containing 25% ethylene glycol-based antifreeze.

DRAINING THE LIQUID

- Open the engine hood.
 - Unscrew the thumbwheel 1 to lower the access panel 2.
- N.B.: When removing cover plates and hatches, clean the surrounding area and remove any accumulations of flammable materials.
- Place a container under radiator drain plug 3 and unscrew the plug.
 - Remove filler plug 4 from the expansion tank and fully open the heating control to ensure correct drainage.
 - Let the cooling circuit drain entirely while ensuring that the ports do not get clogged.
 - Check the condition of the hoses as well as the fastening devices and change the hoses if necessary.
 - Rinse the circuit with clean water and use a cleaning agent if necessary.

FILLING WITH COOLANT

- Refit and tighten the radiator drain plug 3.
- Slowly fill the circuit with coolant (⚠ LUBRICANTS AND FUEL) up to the middle of the expansion tank 5 by the filler hole.
- Refit the filler plug 4.
- Run the engine at idle for a few minutes.
- Check for any possible leaks.
- Refit the access panel 2 and retighten the thumbwheel 1.
- Check the level and top up if necessary.



REPLACE

Dry air filter cartridge

Prefiltration elements are available for use in very dusty conditions (⚠ FILTER CARTRIDGES AND BELTS). Also, the checking and cleaning periodicity of the cartridge must be reduced (up to 250 hours in a very dusty atmosphere and with pre-filtration).

⚠ IMPORTANT ⚠

Change the cartridge in a clean location, with the engine stopped. Never operate the lift truck with a cartridge removed or damaged.

- Open the engine hood.
- Release the lock 1 and pivot the cover 2 to remove it.
- Gently remove the cartridge 3 to reduce dust falling as far as possible.
- Leave the safety cartridge in place.
- Carefully clean the following parts with a damp, clean lint-free cloth.
 - The inside of the filter and cover.
 - The inside of the filter inlet hose.
 - The gasket surfaces in the filter and in the cover.
- Check pipes and connections between the air filter and the engine and the connection and state of the clogging indicator on the filter.
- Before fitting check the condition of the new cartridge (⚠ FILTER CARTRIDGES AND BELTS).
- Insert the cartridge in the filter axis and push the cartridge pressing against the outer edge and not in the center.
- Reassemble the cover, guiding the valve downwards.

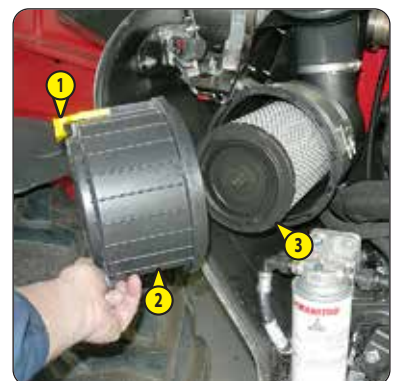

REPLACE

Fuel pre-filter

⚠ IMPORTANT ⚠

*Carefully clean the outside of the pre-filter and its holder, to prevent dust from getting into the system.
Tighten the fuel filter by hand only and lock in place by a quarter turn.*

- Switch off the lift truck's ignition.
- Open the engine hood.
- Close the diesel supply with valve 1.
- Disconnect electrical wiring harness 2 from the fuel pre-filter.
- Place a hose on the drain plug 3 and the other end in a container.
- Unscrew the drain plug 3 by two turns.
- Open bleed screw 4 to ensure proper emptying.
- Retighten bleed screw 4 once the pre-filter is emptied.
- Loosen pre-filter 5 and discard it, together with its seal.
- Clean the inside of the pre-filter head using a brush impregnated with clean diesel oil.
- Refit a pre-filter and a new seal lubricated with clean diesel beforehand (⇐ FILTER CARTRIDGES AND BELTS).
- Reconnect electrical wiring harness 2 on the fuel pre-filter.
- Replace the fuel filter.



REPLACE

Fuel filter

⚠ IMPORTANT ⚠

Carefully clean the outside of the filter and its holder, to prevent dust from getting into the system.

- Unscrew and discard the fuel filter 1.
- Clean the inside of the filter head using a brush immersed in clean diesel oil.
- Refit a filter and a new seal lubricated with clean diesel beforehand (⇐ FILTER CARTRIDGES AND BELTS).
- Tighten the filter, making sure that the seal is correctly positioned (tightening torque 10 - 12 N.m).
- Open the diesel supply with valve 2.
- Open the bleed screw 4 of the fuel pre-filter and the bleed screw 3 of the fuel filter.
- Switch on the lift truck's ignition, and close the bleed screw as soon as the diesel flows with no air.



REPLACE

"DEF" (Diesel Exhaust Fluid) supply pump filter

Place the lift truck on level ground with the engine stopped.

⚠ IMPORTANT ⚠

*Diesel exhaust fluid is corrosive: protect the bodywork and wear personal protective equipment (gloves and goggles).
Carefully clean the outside of the fuel filter, to prevent dust from getting into the system.*

- Switch off the lift truck's ignition and wait for the pump to stop.
- Unscrew the pump cover 1, remove the compensation element 2 and discard.
- Insert the extraction tool 3 (provided with the new filter) into the filter 4 until a click is heard or felt.
- Pull the tool to extract and discard the assembly.
- Lightly oil the cover joint with clean engine oil.
- Replace with a new filter and compensation element (↔ FILTER CARTRIDGES AND BELTS) in the pump and screw the cover 1 (torque 23 N.m).

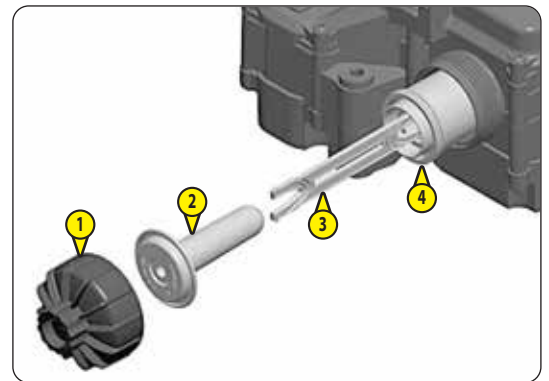
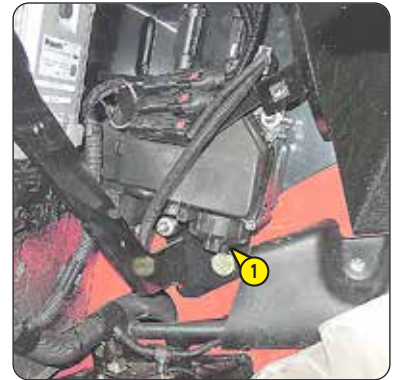

REPLACE

Tank filling strainer "DEF" (diesel exhaust fluid)

- Remove the filler plug 1.
- Unlock strainer 2 and replace with a new one (↔ FILTER CARTRIDGES AND BELTS).
- Remove the filler plug 1.



REPLACE

Gearbox oil

CLEAN

Gearbox sump strainer

Place the lift truck on level ground with the engine stopped and the gearbox oil still warm.

⚠ IMPORTANT ⚠

Raise the boom and place the boom safety wedge on the rod of the lifting cylinder (↖ 1 - INSTRUCTIONS AND SAFETY RECOMMENDATIONS: LIFT TRUCK MAINTENANCE INSTRUCTIONS).

Dispose of the used oil in an ecological manner.

DRAINING THE OIL

- Place a container under drain plug 1 and under cover 2 and unscrew the drain plug.
- Remove the cover plate 3.

N.B.: When removing cover plates and hatches, clean the surrounding area and remove any accumulations of flammable materials.

- Remove dipstick 4 and unscrew filling plug 5 in order to ensure that the oil is drained properly.

CLEANING THE SUCTION STRAINER

- Remove cover 2 and set aside the O-ring joint and sealing washer.
- Allow the rest of the oil to drain away.
- Remove and clean the strainer using a compressed air jet.
- Clean the magnetic section on the plate.
- Refit the assembly and tighten up plate 2 (tightening torque 18 - 31 N.m).

FILLING WITH OIL

- Refit and tighten the drain plug 1 (tightening torque 34 - 54 N.m).
- Fill up with oil (↖ LUBRICANTS AND FUEL) through the filler port 5 and refit the plug.
- Start the engine and let it run for a few minutes.
- Check any possible leaks from the drain plug or cover.
- Stop the engine, and within 5 minutes of the engine being stopped, check the correct level between the MIN and MAX marks on the dipstick 4.
- Top up the level, if necessary.
- Refit cover plate 3.



REPLACE

Front wheel reducer oil

REPLACE

Rear wheel reducer oil

Place the lift truck on level ground with the engine stopped and the reducers' oil still warm.

⚠ IMPORTANT ⚠

Dispose of the used oil in an ecological manner.

- Drain and change the oil of each wheel reduction gear.
- Place drain plug 1 in position A.
- Place a container under the drain plug and unscrew the plug.
- Let the oil drain fully.
- Place the drain port in position B, i.e. in a level port.
- Fill up with oil (↖ LUBRICANTS AND FUEL) through level hole 1.
- The level is correct when the oil level is flush with the edge of the hole.
- Refit and tighten the drain plug (tightening torque 34 - 49 N.m).



CHECK	Engine shock mounts *
CHECK	Gearbox silent blocks *
CHECK	Gearbox controls *
CHECK	Brake system pressure *
CHECK	Boom pad wear *
CHECK	Condition of wiring harnesses and cables *
CHECK	Lights and signals *
CHECK	Warning indicators *
CHECK	Condition of the rear view mirrors *
CHECK	Cab structure *
CHECK	Chassis structure *
CHECK	Attachment mounting system *
CHECK	Condition of attachments *

*** Consult your dealer.**

🔄 2000H - PERIODIC MAINTENANCE - EVERY 2000 HOURS OF SERVICE OR EVERY 4 YEARS

ALSO PERFORM THE 500 HOUR AND 1000 HOUR PERIODIC MAINTENANCE.

CHECK

Wheel nut tightening torque

- Check the condition of the tires, to detect cuts, blisters, wear, etc.
- Check the tightening torque of the wheel nuts with a torque wrench:
 - Front wheels = 630 N.m ± 94 N.m
 - Rear wheels = 630 N.m ± 94 N.m

CLEAN

Air conditioning (OPTION) *

CLEANING CONDENSER AND EVAPORATOR COILS

CLEANING CONDENSATE TRAY AND RELIEF VALVE

COLLECTING COOLANT TO REPLACE DRIER FILTER

REFILLING WITH COOLANT AND CHECKING THE THERMOSTATIC CONTROL AND PRESSURE SWITCHES

N.B.: When opening the evaporator unit, remember to replace the cover seal.

⚠️ IMPORTANT ⚠️

NEVER TRY TO REPAIR ANY FAULTS YOURSELF. WHEN REFILLING CIRCUITS, ALWAYS REFER TO A DEALER WHO HAS THE CORRECT SPARE PARTS AND THE TECHNICAL KNOWLEDGE AND TOOLS REQUIRED.

In any of the following circumstances, call a doctor.

If inhaled, take the victim to fresh air.

If there is contact with the skin, wash immediately with plenty of water.

If there is frostbite, apply a sterile dressing.

If there is contact with the eyes, rinse with clear water for 15 minutes.



IMPORTANT INFORMATION REGARDING THE COOLANT USED

- This product contains fluorinated greenhouse gases covered by the Kyoto Protocol.
- Coolant type: R134A; it is colorless and odorless and heavier than air. Its GWP (Global Warming Potential) is 1430.
- Do not allow the gases to escape into the atmosphere. Do not open the system under any circumstances, as this could cause refrigerant to escape.
- The compressor has a fluid level gage; never unscrew this gage because it would depressurize the system. The fluid level should only be checked when draining the system.

** Consult your dealer.*

REPLACE

Dry air filter safety cartridge

⚠️ IMPORTANT ⚠️

The safety cartridge replacement frequency is given for information only. It must be changed every second time the dry air filter cartridge is changed.

- For the dismantling and refitting of the cartridge (< 1000H: REPLACE Air filter cartridge).
- Carefully remove the dry air filter safety cartridge 1 to reduce dust fall as much as possible.
- Clean the gasket surface on the filter with a damp, clean lint-free cloth.
- Check the condition of the new safety cartridge before fitting (< FILTER CARTRIDGES AND BELTS).
- Insert the cartridge in the filter axis and push the cartridge pressing against the outer edge and not the center.



REPLACE

Alternator belt

- Open the engine hood.
- Remove the protective casing 1.

REMOVING THE BELT

- Place a 1/2 in. socket wrench in the square of the automatic tensioner 2.
- Turn the socket wrench counterclockwise, and block the tensioner with a tool 3 (pin punch) to slacken and remove the belt.
- Remove the alternator belt 4.

N.B.: Take the opportunity provided by the removal of the belt to check that the pulleys and bearings are working correctly (noise, friction, play, etc.).

REFITTING THE BELT

- Refit a new alternator belt (↖ FILTER CARTRIDGES AND BELTS). Ensure that it is properly seated in the grooves of each pulley.
- Continue to apply force to the socket wrench, remove the tool 3 (pin punch) and release the force on the socket wrench.
- Check that the belt is correctly positioned.
- Refit the protective casing 1.

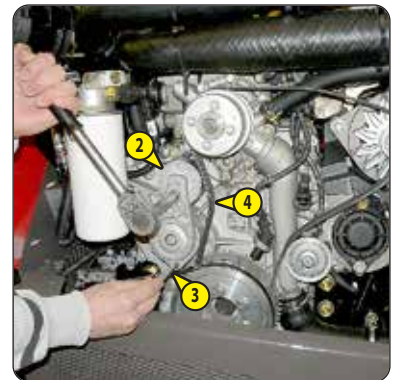

REPLACE

Angle gear box oil

Place the lift truck on level ground with the engine stopped.

- Place a container under drain plug 1 and unscrew the plug.
- Remove level and filling plug 2 to ensure correct drainage.
- Refit and tighten the drain plug 1 (tightening torque 25 - 35 N.m).
- Fill up with oil (↖ LUBRICANTS AND FUEL) through filler hole 2.
- The level is correct when the oil level is flush with the edge of opening 2.
- Check for any possible leaks at the drain plug.
- Refit and tighten the level and filling plug 1 (tightening torque 25 - 35 N.m).

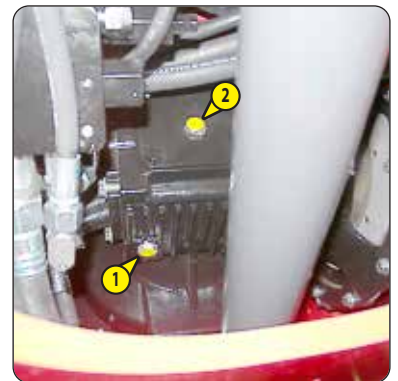

REPLACE

Hydraulic oil

CLEAN

Hydraulic oil tank suction strainer

REPLACE

Ventilation reversal filter

Place the lift truck on level ground with the engine shut down and the boom retracted and lowered as far as possible.

⚠ IMPORTANT ⚠

Before any intervention, thoroughly clean the area surrounding the filter, the drain plugs and the suction cover on the hydraulic tank.

Dispose of the used oil in an ecological manner.

Use a clean container and funnel and clean the underside of the oil drum before filling.



DRAINING THE OIL

- Place a container under drain plugs 1 and unscrew them.
- Remove level and filling plug 2 to ensure that the oil is drained properly and discard.

CLEANING THE SUCTION STRAINER

- Remove hose 3.
- Remove and clean the suction strainer 4 using a compressed air jet, check its condition and replace if necessary (⇐ FILTER CARTRIDGES AND BELTS).
- Refit the strainer 4 and hose 3 making sure the seal is in the correct position.



REPLACING THE VENTILATION REVERSAL FILTER

⚠ IMPORTANT ⚠

Be careful to mount the filter 6 in the same direction as the arrow.

- Unscrew the filter 6 and replace it with a new one (⇐ FILTER CARTRIDGES AND BELTS).

FILLING WITH OIL

- Clean and refit the drain plugs 1 (tightening torque 29 - 39 N.m).
- Fill up with oil (⇐ LUBRICANTS AND FUEL) through filler hole 5.
- Observe the oil level on the dipstick 7. The oil level should be at the MAX mark.
- Check for any possible leaks at the drain plugs.
- Fit a new filler plug 2.



CHECK	Radiator *
CHECK	Transmission pressures *
CHECK	Steering *
CHECK	Steering swivel joints *
CHECK	Condition of boom assembly *
CHECK	Bearings and bushings of the boom *
CHECK	Condition of hoses and flexible pipes *
CHECK	Condition of cylinders (leakage, rods) *
CHECK	Hydraulic circuit pressures *
CHECK	Chassis bearings and bushings*
REPLACE	Compressor belt (Air Conditioning OPTION) *

** Consult your dealer.*

Clean any traces of fuel, oil or grease from the lift truck or at least the area in question before carrying out any work.

EXTERIOR WASHING

- Close and lock all accesses to the lift truck (doors, windows, cowls, etc.).
- When washing with a high pressure cleaner, avoid the hinges and electrical components and connections.
- If necessary, protect components susceptible to damage, particularly electrical components and connections and the exhaust outlet, against penetration of water, steam or cleaning agents.
- After washing, leave the lift truck to dry in the open air and do not park inside a building.

INTERIOR WASHING

- Avoid cleaning the engine, the harnesses, the electrical components and parts with sensitive seals (e.g. universal joint cross-piece) with a high pressure cleaner. Clean with compressed air instead.
- Clean any accumulation of flammable materials near to heat sources and electrical components.
- Special attention should be paid to all the areas of the lift truck where these high-risk materials are likely to accumulate (e.g. engine compartment, under the boom, above the axles, etc.).

⚠ IMPORTANT ⚠

If you are performing regeneration during the periodic 500-hour service, do the regeneration before replacing the engine oil.

- Park the lift truck in a safe and adequately ventilated place.
- Check the following points:
 - forward/reverse selector in neutral,
 - parking brake activated,
 - no action on the hydraulic control joystick,
 - boom in transport position,
 - idling speed,
- Check that the fuel level is sufficient.
- Start the lift truck and run the engine for a few minutes to bring it up to its normal operating temperature.
- Press the top of button  and hold for at least two seconds to launch exhaust regeneration. The indicator lamp comes on fixed and the engine speed increases, confirming the start of regeneration.
- The length of the exhaust regeneration procedure varies (between 40 and 50 minutes).

⚠ IMPORTANT ⚠

Exhaust regeneration must only be stopped if absolutely necessary.

Regeneration stops automatically if the operator:

- *activates the hydraulic control joystick,*
- *engages forward or reverse gear,*
- *switches off the engine,*
- *presses switch 1.*

- When regeneration has finished, the indicator lamp  goes out and the countdown before next regeneration screen returns to 700 hours (700h => 0h).

REPLACE

Wheels

For this operation, we advise you to use the hydraulic jack (MANITOU part no.: 505507) and the safety support prop (MANITOU part no.: 554772).

⚠ IMPORTANT ⚠

In the event of a wheel being changed on the public highway, secure the lift truck vicinity:

- Stop the lift truck, if possible on firm, level ground.
- Stop the lift truck (☞ 1 - SAFETY INSTRUCTIONS: DRIVING INSTRUCTIONS UNLADEN AND LADEN).
- Switch on the hazard warning lights.
- Immobilize the lift truck in both directions on the axle opposite to the wheel to be changed.
- Unlock the nuts of the wheel to be changed.
- Place the jack under the flared axle tube (☞ ) , as near as possible to the wheel, and adjust the jack.
- Raise the wheel until it is clear of the ground and place the safety support under the axle.
- Completely unscrew the wheel nuts and remove them.
- Free the wheel using back and forth movements and roll it to the side.
- Slip the new wheel on the wheel hub.
- Hand-tighten the nuts, grease them if necessary.
- Remove the safety support and lower the lift truck with the jack.
- Tighten the wheel nuts to the prescribed torque value (☞ 2000H - PERIODIC MAINTENANCE - EVERY 2,000 HOURS OF SERVICE OR EVERY 4 YEARS) using a torque wrench.



REPLACE

Battery

⚠ IMPORTANT ⚠

Switch off the ignition with the key, wait 30 seconds, then operate the battery cut-off.

Wait 5 minutes before disconnecting the battery, this is required in order to purge the Diesel Exhaust Fluid (DEF) system.

Handling and servicing a battery can be dangerous. Take the following precautions:

- Wear protective goggles.
- Keep the battery horizontal.
- Never smoke or work near a naked flame.
- Work in a well-ventilated area.

- In the event of electrolyte being spilled onto the skin or splashed in the eyes, rinse thoroughly with cold water for 15 minutes and call a doctor.

- Open the engine hood.
- Bring a back-up battery of the same type as the one used for the lift truck, together with battery cables.
- Connect the back-up battery, respecting the polarity (-) (+).
- Start the lift truck and remove the cables as soon as the engine is running.

⚠ IMPORTANT ⚠

Raise the boom and place the boom safety wedge on the rod of the lifting cylinder (⚠ 1 - INSTRUCTIONS AND SAFETY RECOMMENDATIONS: LIFT TRUCK MAINTENANCE INSTRUCTIONS).

- Remove the protective casing 1.
- Replace the battery

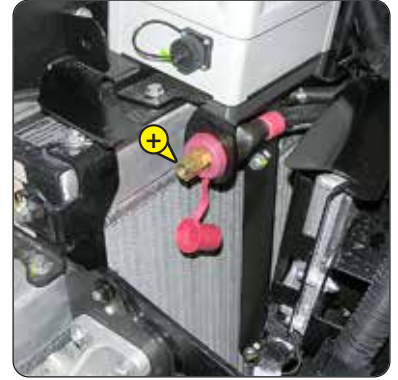

ADJUST

Front headlights

RECOMMENDED SETTING

(according to standard ECE-76/756 76/761 ECE20)

Adjustment of -2 % of the dipped beam harness relative to the horizontal axis of the headlight.

ADJUSTMENT PROCEDURE

- Place the unladen lift truck in the transport position and perpendicular to a white wall on flat, level ground.
- Check the tire pressures (⚠ 2 - DESCRIPTION: TIRES).
- Put the gearshift lever in neutral.

CALCULATING THE HEIGHT OF THE DIPPED BEAM (H2)

- h1 = Height of the dipped beam in relation to the ground.
- h2 = Height of the adjusted beam.
- l = Distance between the dipped beam and the white wall.

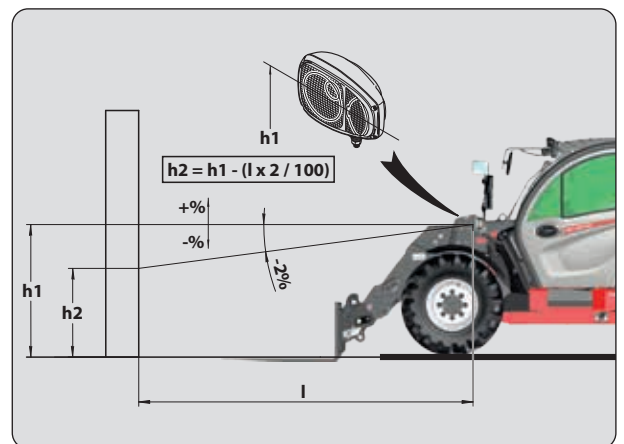

RESET

Longitudinal stability limiter and warning device

According to the use of the lift truck, the device may need to be periodically reset.

This operation can be easily performed by means of the following procedure.

- Provide a fork carrier or a bucket and a load corresponding to at least half the lift truck's rated capacity.
- Preferably perform the reset when the lift truck is still cold (before it is used) or ensure that the temperature of the rear axle is not more than 50 °C.

⚠ IMPORTANT ⚠

Carefully follow the boom positioning instructions.

*When the reset is completed, check the operation of the longitudinal stability limiter and warning device
(\triangleleft 10H - DAILY MAINTENANCE OR EVERY 10 HOURS OF SERVICE).*

If in doubt, consult your dealer.

- Place the lift truck on flat, level ground with the wheels straight.
- Press button B to display the "PREFERENCE" menu
- Turn knob A to navigate through the menus and sub-menus.



HYDRAULIC	>	STABILITY REBALANCING
-----------	---	-----------------------

- Press knob A to confirm.
- Follow the steps described on the information screen (OK = press button A).

↻ OCCASIONAL OPERATION

TOW OR WINCH

Lift truck

⚠ IMPORTANT ⚠

Do not tow the lift truck at more than 15 km/h, and abide by local traffic regulations.

- Place the forward/reverse selector and the gear lever in neutral.
- Release the hand brake.
- Switch on the hazard warning lights.
- Remove the cotter pin 1, lift the towing pin 2 and place the drawbar on the towing pin.

N.B.: Since there will be no power steering or hydraulic brake assistance, operate the steering and controls slowly and forcefully. Avoid sudden or jerky movements.



SLING

Lift truck

- Take into account the position of the lift truck center of gravity for lifting.

A = 1410 mm B = 1280 mm

- Place the hooks in the anchoring points 1 provided.

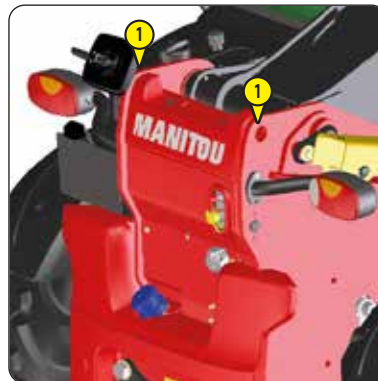
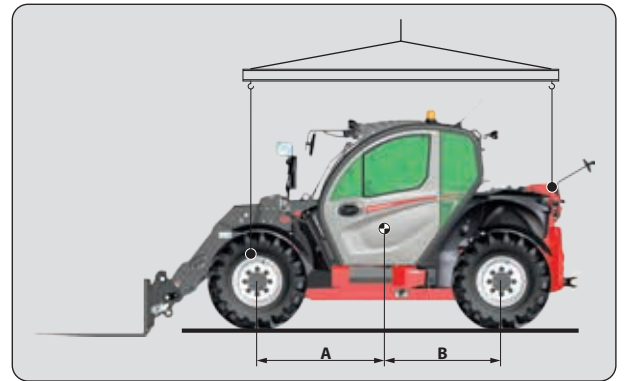

⚠ IMPORTANT ⚠

Check that the safety instructions associated with the transport vehicle have been correctly applied before loading the machine and ensure that the driver of the vehicle has been informed of the dimensional characteristics and total weight of the machine.

Ensure that the transport vehicle has adequate dimensions and load capacity for transporting the machine, \triangleleft SPECIFICATIONS and STICKERS.

Covers must be closed and locked while the machine is being transported.

⚠ IMPORTANT ⚠

The transport vehicle must be parked on a level surface and the wheels must be chocked to prevent it from rolling during loading and unloading of the machine.

For machines equipped with a turbo-charged engine, block off the exhaust outlet to avoid rotation of the turbo shaft without lubrication when transporting the vehicle.

The machine must be loaded or unloaded using a winch if the loading ramps are slippery, \triangleleft FREEWHEELING FOR TOWING/WINCHING.

The angle of the loading ramps must not exceed the maximum slope accessible value, \triangleleft SPECIFICATIONS.

The machine must be loaded and unloaded using a crane if the angle of the loading ramps exceeds the maximum slope accessible value, \triangleleft TRANSPORT FOR WINCHING: LIFTING INSTRUCTIONS.

LOADING THE MACHINE ONTO THE TRANSPORT VEHICLE

- Fully retract the telescopic arm.
- Load the machine parallel to the transport vehicle.
- Place the attachment flat on the ground.
- Activate the parking brake.
- Switch off the machine.
- Remove the ignition key.

SECURING THE MACHINE TO THE TRANSPORT VEHICLE

- Fix chocks to the transport vehicle at the front and rear of each of the machine's wheels.
- Fix chocks to the transport vehicle on the inner side of each of the machine's wheels.
- Attach the straps to the machine's anchoring points, \triangleleft STICKERS: ANCHORING POINT.
- Secure the machine, observing the lashing angles (α) and (β) and the resistance (LC) of the straps.

UNLOADING THE MACHINE FROM THE TRANSPORT VEHICLE

- Remove the straps.
- Remove the chocks from the wheels.
- Switch on the machine.
- Raise the telescopic arm.
- Release the parking brake.
- Lower the machine parallel to the transport vehicle.

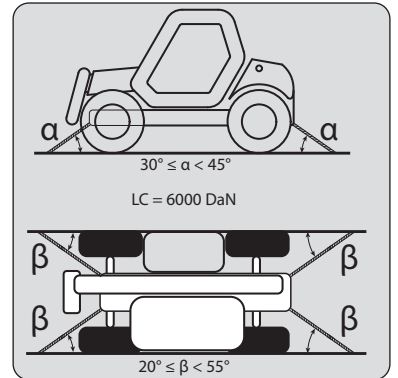
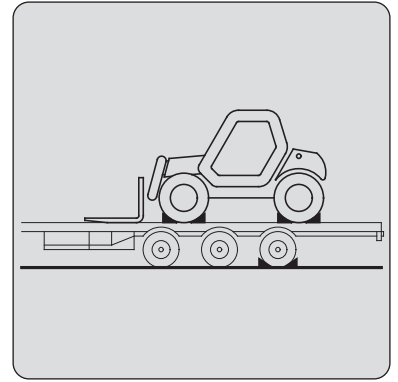

4 - OPTIONAL ADAPTABLE ATTACHMENTS FOR THE RANGE

4 - OPTIONAL ADAPTABLE ATTACHMENTS FOR THE RANGE

<u>INTRODUCTION</u>	4-3
<u>PICKING UP THE ATTACHMENTS</u>	4-4
<u>TECHNICAL SPECIFICATIONS OF ATTACHMENTS</u>	4-6
<u>ATTACHMENT GUARDS</u>	4-14

INTRODUCTION

- Your lift truck must be used with interchangeable equipment. These items are called: ATTACHMENTS.
- A wide range of attachments is available, guaranteed by MANITOU and designed to fit your lift truck perfectly.

⚠ IMPORTANT ⚠

*Only attachments approved by MANITOU can be used on its lift trucks (↪ TECHNICAL SPECIFICATIONS OF ATTACHMENTS).
The manufacturer cannot be held responsible for any modifications or adaptations to attachments without its knowledge.*

- The attachments are delivered with a load chart concerning your lift truck. The operator's manual and the load chart should be kept in the places provided in the lift truck. For standard attachments, their use is governed by the instructions contained on this notice.

⚠ IMPORTANT ⚠

*Maximum loads are defined by the capacity of a lift truck taking account of the attachment's weight and center of gravity.
Should the attachment have a lower capacity than the lift truck, never exceed this limit.*

- Some particular uses require the adaptation of the attachment which is not provided in the price-listed options. Solutions exist, consult your dealer.

⚠ IMPORTANT ⚠

Depending on their size, certain attachments may, when the boom is lowered and retracted, come into contact with the front tires and cause damage to them if excavation is activated in the direction of the discharge.

TO PREVENT THIS RISK, EXTEND THE TELESCOPE TO A SUFFICIENT EXTENT FOR THE PARTICULAR LIFT TRUCK AND ATTACHMENT SO THAT THIS CONTACT IS NOT POSSIBLE.

SUSPENDED LOAD

⚠ IMPORTANT ⚠

*Suspended loads **MUST** be handled with a lift truck designed for that purpose (↪ 1 - OPERATING AND SAFETY INSTRUCTIONS: INSTRUCTIONS FOR HANDLING LOADS: H - LIFTING UP AND SETTING DOWN A SUSPENDED LOAD).*

PICKING UP THE ATTACHMENTS

1 - ATTACHMENT WITHOUT HYDRAULICS AND HAND LOCKING DEVICE

FITTING AN ATTACHMENT

- Ensure that the attachment is in a position facilitating the locking to the carriage. If it is not correctly oriented, take the necessary precautions in order to move it safely.
- Check that the locking pin is in position in the bracket (fig. A).
- Place the lift truck with the boom lowered in front of and parallel to the attachment, and tilt the carriage forward (fig. B).
- Bring the carriage under the locking tube of the attachment, slightly raise the boom, tilt the carriage backward in order to position the attachment (fig. C).
- Lift the attachment off the ground to facilitate locking.

MANUAL LOCKING

- Take the locking pin on the bracket (fig. A) and lock the attachment (fig. D). Do not forget to fit the pin.

MANUAL UNLOCKING

- Proceed in the reverse order to MANUAL LOCKING, taking care to refit the locking pin in the bracket (fig. A).

REMOVING THE ATTACHMENT

- Proceed in the reverse order to FITTING AN ATTACHMENT, taking care to store the attachment flat on the ground and in the closed position.

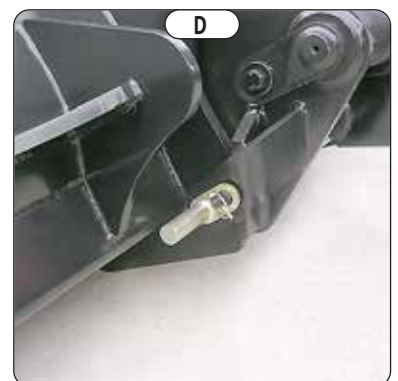
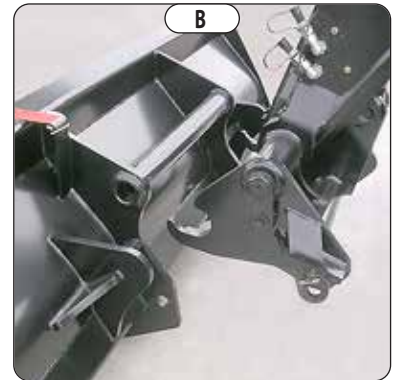
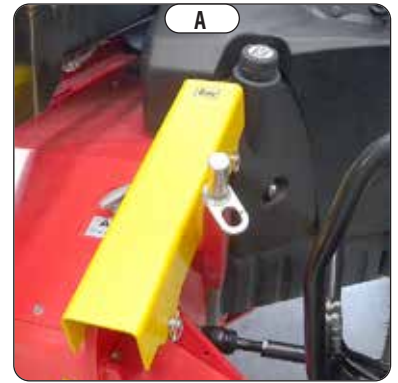

2 - HYDRAULIC ATTACHMENT AND MANUAL LOCKING DEVICE

FITTING AN ATTACHMENT

- Ensure that the attachment is in a position facilitating the locking to the carriage. If it is not correctly oriented, take the necessary precautions in order to move it safely.
- Check that the locking pin is in position in the bracket (fig. A).
- Place the lift truck with the boom lowered in front of and parallel to the attachment, and tilt the carriage forward (fig. B).
- Bring the carriage under the locking tube of the attachment, slightly raise the boom, tilt the carriage backward in order to position the attachment (fig. C).
- Lift the attachment off the ground to facilitate locking.

MANUAL LOCKING AND CONNECTION OF THE ATTACHMENT

⚠ IMPORTANT ⚠

Make sure that the rapid connectors are clean and protect the holes which are not used, with the caps provided.

- Take the locking pin on the bracket and lock the attachment (fig. D). Do not forget to fit the pin.
- Stop the engine and keep the ignition on the lift truck.
- Release the pressure in the attachment hydraulic circuit by operating switch 1 on the distributor lever backwards and forwards 4 or 5 times.
- Connect the quick-release couplers according to the logic of the attachment's hydraulic movements.

MANUAL RELEASE AND DISCONNECTION OF THE ATTACHMENT

- Proceed in the reverse order of paragraph MANUAL LOCKING AND CONNECTION OF THE ATTACHMENT, taking care to refit the locking pin in the bracket.

REMOVING THE ATTACHMENT

- Proceed in the reverse order to FITTING AN ATTACHMENT, taking care to store the attachment flat on the ground and in the closed position.

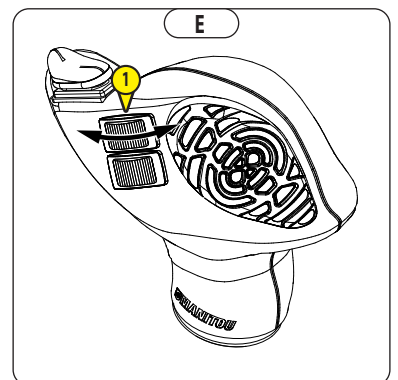
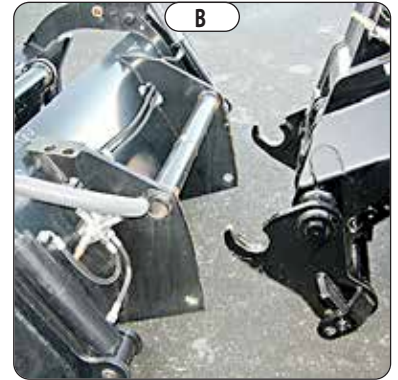
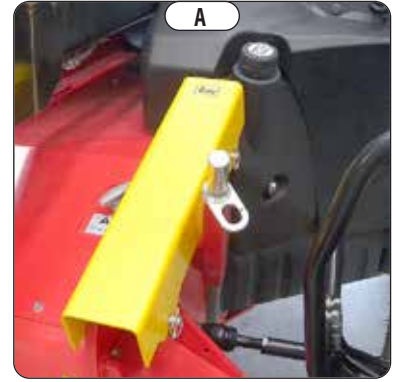

TECHNICAL SPECIFICATIONS OF ATTACHMENTS

STANDARDIZED TILTING FORK CARRIAGE

REFERENCE	PFB 35 N MT-1260 S2	PFB 35 N MT-1470 S2	PFB 35 N MT-1580 S2
Rated capacity	653744 3500 kg	653745 3500 kg	653746 3500 kg
Width	1260 mm	1470 mm	1580 mm
Weight	95 kg	120 kg	125 kg

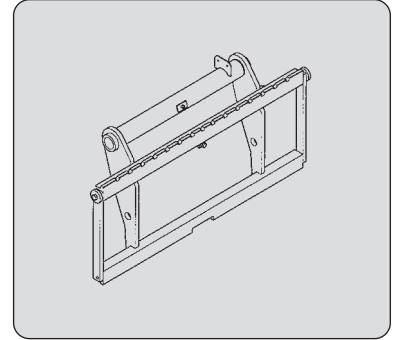

STANDARDIZED FORK

REFERENCE	415618
Section	125x45x1200 mm
Weight	72 kg

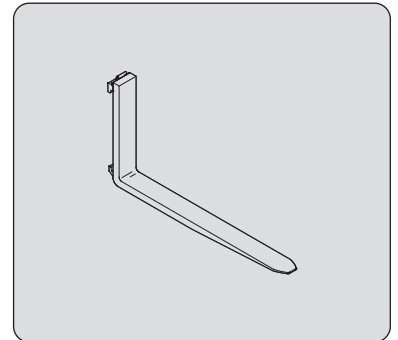

STANDARDIZED TILTING FORK CARRIAGE + LOAD BACK REST

REFERENCE	PFB 35N 1260 LB	PFB 35N 1470 LB
Rated capacity	52000200 3500 kg	52000201 3500 kg
Width	1260 mm	1470 mm
Weight	130 kg	158 kg

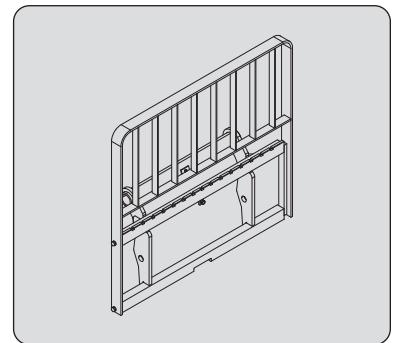

STANDARDIZED TILTING FORK CARRIAGE + STANDARDIZED SIDE-SHIFT CARRIAGE

REFERENCE	PFB 35 N 1260 DL	PFB 35 N 1580 DL
Rated capacity	52000101 3150 kg	52000102 3150 kg
Side-shift	2x100 mm	2x100 mm
Width	1260 mm	1580 mm
Weight	175 kg	300 kg

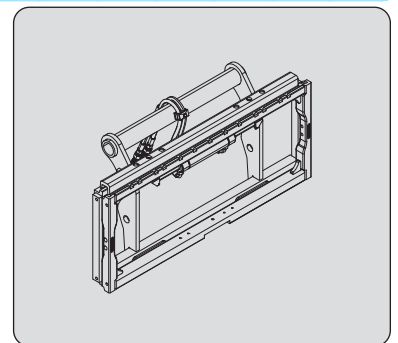

STANDARDIZED TILTING FORK CARRIAGE + STANDARDIZED SIDE-SHIFT CARRIAGE + LOAD BACK REST

REFERENCE	PFB 35 N 1260 DL/LB
Rated capacity	52000205 3150 kg
Side-shift	2x100 mm
Width	1260 mm
Weight	210 kg

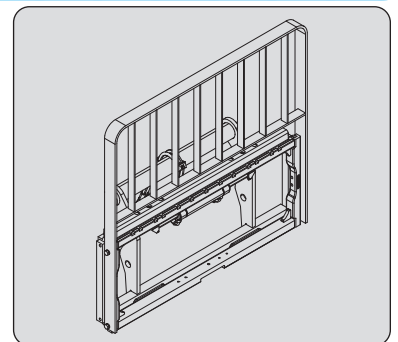

FLOATING FORK CARRIAGE

	TFF 35 MT-1040	TFF 35 MT-1300
REFERENCE	654093	654094
Rated capacity	3500 kg	3500 kg
Width	1040 mm	1300 mm
Weight	300 kg	340 kg

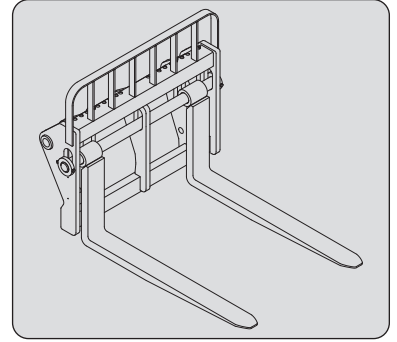

FLOATING FORK

	415801
REFERENCE	415801
Section	125x45x1200 mm
Weight	68 kg

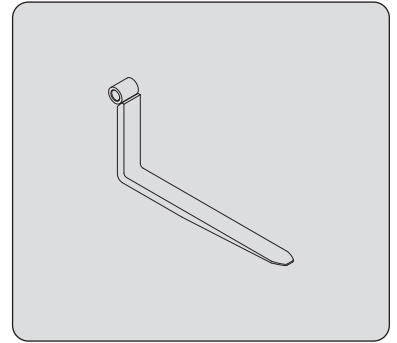

BUCKET WITH GRAB

REFERENCE	CBG 2100 MS 790304	CBG 2300 MS 790306
Rated capacity	1090 ℓ	1190 ℓ
Width	2100 mm	2300 mm
Teeth	7	7
Weight	681 kg	720 kg

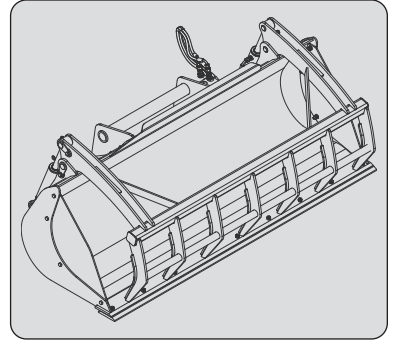

BUCKET WITH GRAB

REFERENCE	BG 2100/1200 WE 52647328	BG 2300/1350 WE 52647330
Rated capacity	1200 ℓ	1335 ℓ
Width	2100 mm	2300 mm
Teeth	8	8
Weight	745 kg	785 kg

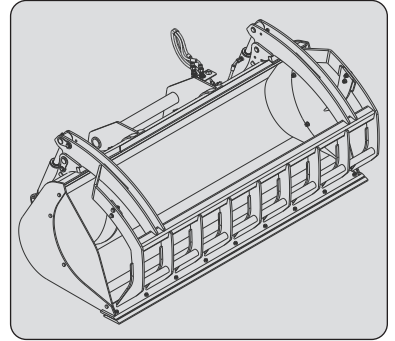

BUCKET WITH GRAB

REFERENCE	BG 2100/1200 FO 52647329	BG 2300/1350 FO 52647331
Rated capacity	1200 ℓ	1335 ℓ
Width	2100 mm	2300 mm
Teeth	8	9
Weight	720 kg	763 kg

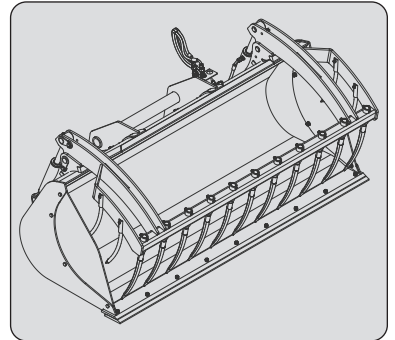

BUILDING BUCKET

REFERENCE	CBC 750 L2100 654475	CBC 800 L2250 654471
Rated capacity	768 ℓ	814 ℓ
Width	2100 mm	2250 mm
Weight	345 kg	366 kg

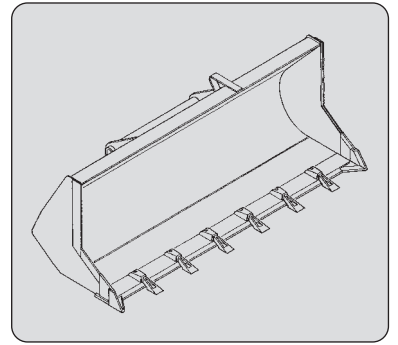

LOADING BUCKET

REFERENCE	CBR 850 L2100 653047	CBR 900 L2250 653749
Rated capacity	778 ℓ	904 ℓ
Width	2100 mm	2250 mm
Weight	358 kg	360 kg

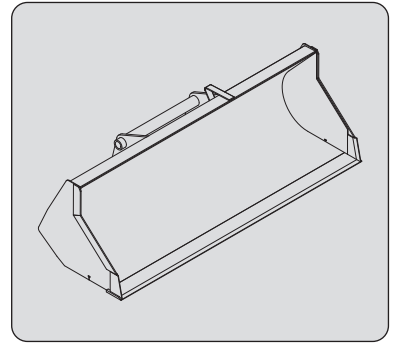

GRAIN BUCKET

REFERENCE	CBA 1700 L2100 S3 570549	CBA 2000 L2250 S3 790540
Rated capacity	1703 ℓ	1970 ℓ
Width	2100 mm	2250 mm
Weight	522 kg	585 kg

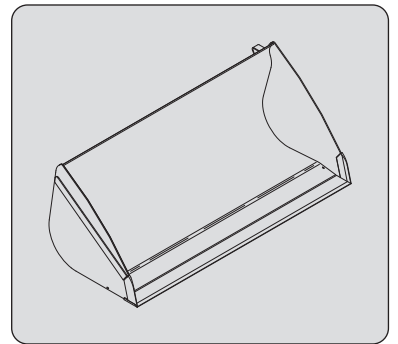

FARMING BUCKET (REMOVABLE AND REVERSIBLE BLADE)

REFERENCE	CBA 1700 L21000 LDR S3 52610570	CBA 2000 L2250 LDR S3 790541
Rated capacity	1643 ℓ	1970 ℓ
Width	2100 mm	2250 mm
Weight	522 kg	625 kg

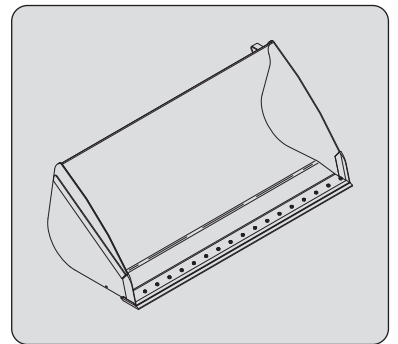

SPREADER GRAB SHELL

	CGD 2200/2100 FO
REFERENCE	790311
Rated capacity	2100 ℓ
Width	2200 mm
Teeth	11
Weight	1140 kg

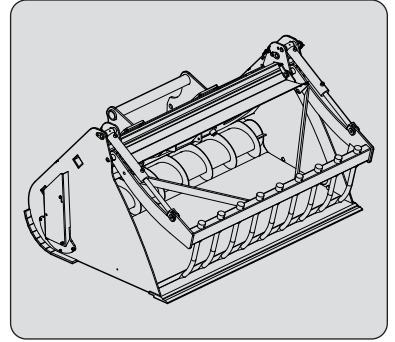

SHEAR GRAB

	SHG 1800/1350
REFERENCE	52000381
Rated capacity	1315 ℓ
Width	1800 mm
Weight	749 kg

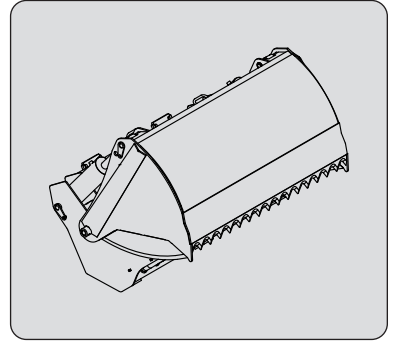

MANURE FORK WITH GRAB

	FFGR 30 MT 1950 S5	FFGR 30 MT 2100 S5
REFERENCE	751404	751403
Rated capacity	1580 kg	1700 kg
Width	1950 mm	2100 mm
Finger	9	10
Teeth	7	7
Weight	477 kg	492 kg

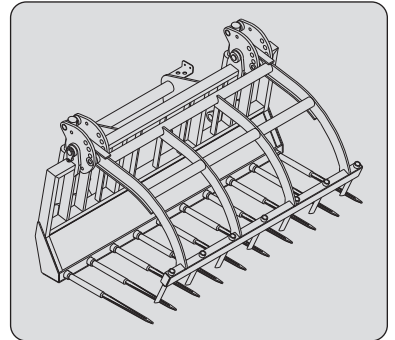

BALE CLAMP

REFERENCE	PBG 2X2 757639
Rated capacity	800 kg
Width	1090 mm
Teeth	2x2
Weight	158 kg

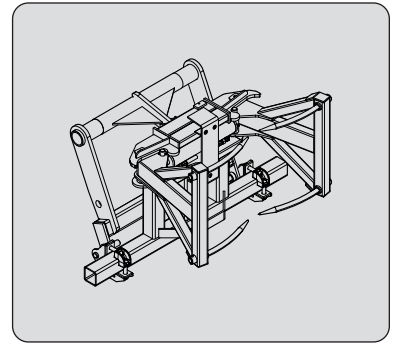

BALE CLAMP

REFERENCE	PBG 2X4 757612
Rated capacity	1000 kg
Width	1300 mm
Teeth	2x4
Weight	262 kg

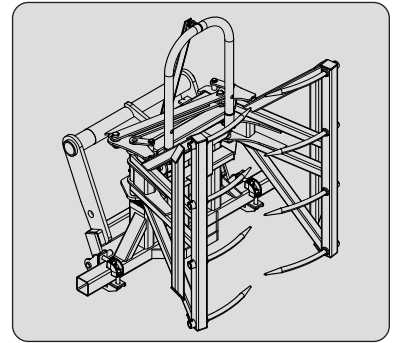

BALE CLAMP

REFERENCE	P2BG 2X4 790518
Rated capacity	1500 kg
Width	1090 mm
Teeth	2x4
Weight	275 kg

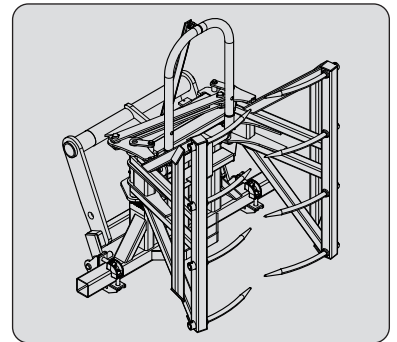

BALE CLAMP

REFERENCE	MBC 2X3 790506
Rated capacity	800 kg
Width	1196 mm
Weight	290 kg

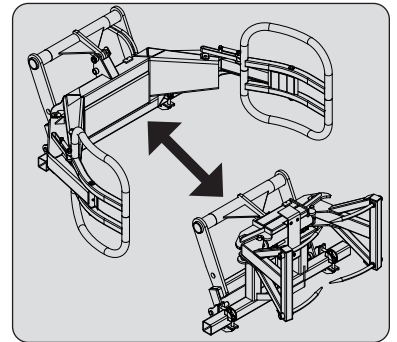

BALE CLAMP

REFERENCE	PBE 757613
Rated capacity	1000 kg
Width	1600 mm
Weight	242 kg

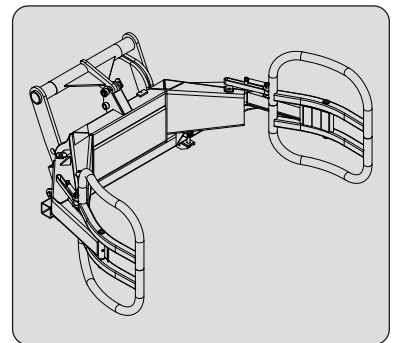

BALE CLAMP

	CLBW 800 52000813	CLBW 1500 52001012
REFERENCE		
Rated capacity	800 kg	1500 kg
Width	1634 mm	1952 mm
Weight	227 kg	251 kg

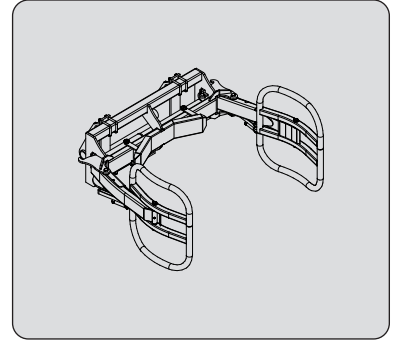

BALE CLAMP

	CLBR 2X3 52001013
REFERENCE	
Rated capacity	1200 kg
Width	1090 mm
Teeth	2x3
Weight	235 kg

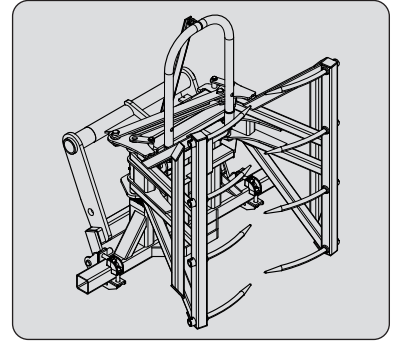

BALE FORK

	FB 1900/1700 790699
REFERENCE	
Rated capacity	1700 kg
Width	1878 mm
Teeth	4
Weight	215 kg

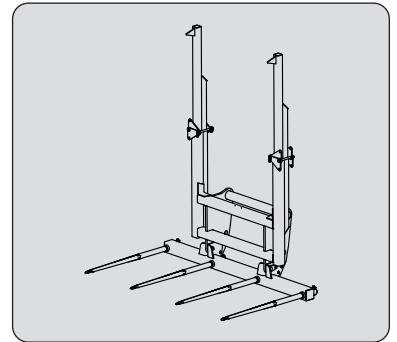

BOOM CRANE WITH BIG BAG

	HBB 1500/2400 931627
REFERENCE	
Rated capacity	2400 kg
Weight	186 kg

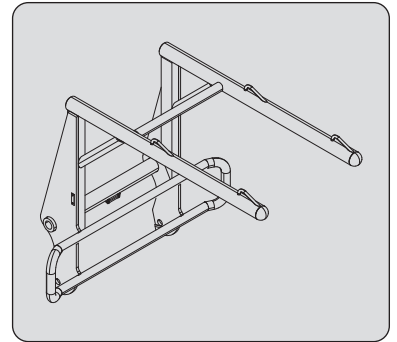

CRANE

	PC 50 708544
REFERENCE	
Rated capacity	5000 kg
Weight	120 kg

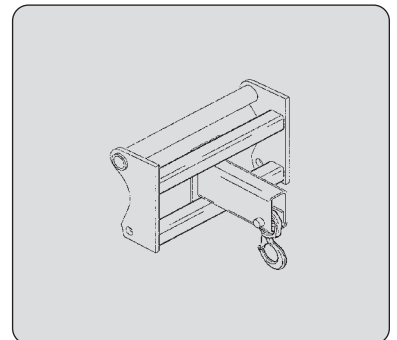

SWEeper COLLECTOR WITH BRUSH

REFERENCE	BRB 2200
	790315
Rated capacity	530 ℓ
Width	2600 mm
Weight	925 kg

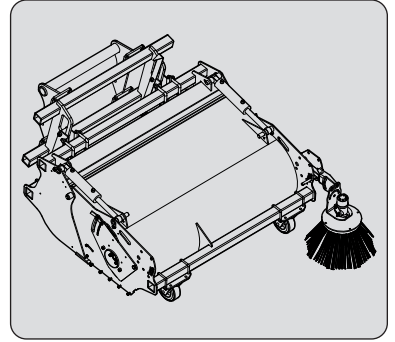

SWEeper WITH BRUSH

REFERENCE	SCC 2600
	52000515
Rated capacity	2600 mm
Width	2820 mm
Weight	725 kg

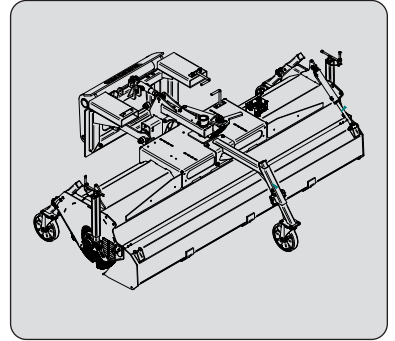

SWEeper WITH BRUSH

REFERENCE	SCC 2600+
	52000517
Rated capacity	2600 mm
Width	2820 mm
Weight	780 kg

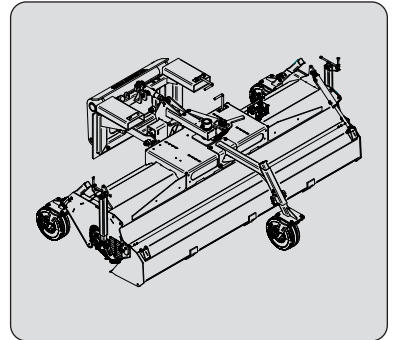

SWEeper WITH BRUSH

REFERENCE	SCC 2600 HWA+
	52000519
Rated capacity	2600 mm
Width	2820 mm
Weight	795 kg

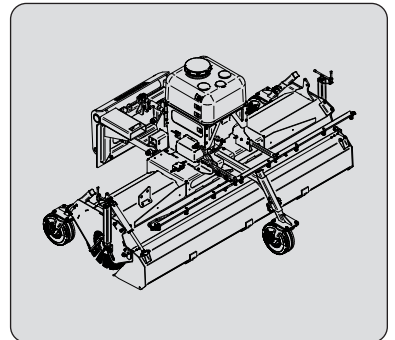

HIGH PRESSURE SCRUBBER

REFERENCE	VHPC 600
	790335
Rated capacity	600 ℓ
Width	1450 mm
Weight	240 kg

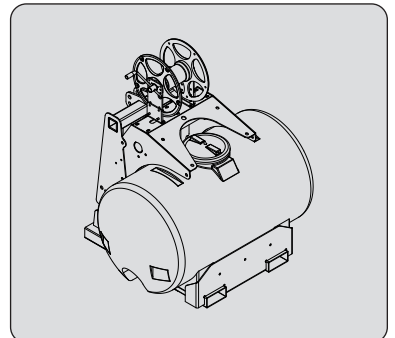

ATTACHMENT GUARDS

FORK GUARD

REFERENCE 227801

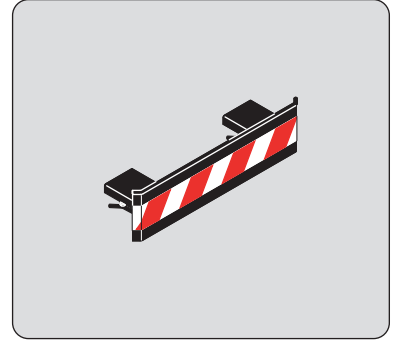

FORK BLOCK FOR FLOATING FORK CARRIAGE

REFERENCE 261210

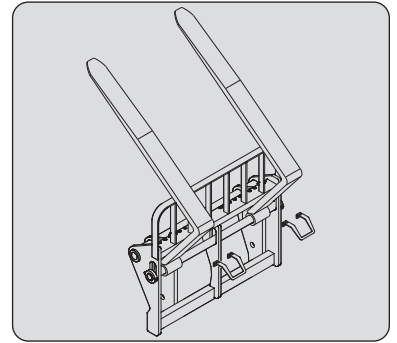

BUCKET PROTECTOR

Always ensure that the width of the protector you choose is less than or equal to the width of the bucket.

Width	REFERENCE 206734	206732	206730
	1375 mm	1500 mm	1650 mm
Width	REFERENCE 235854	206728	206726
	1850 mm	1950 mm	2000 mm
Width	REFERENCE 223771	223773	206724
	2050 mm	2100 mm	2150 mm
Width	REFERENCE 206099	206722	223775
	2250 mm	2450 mm	2500 mm

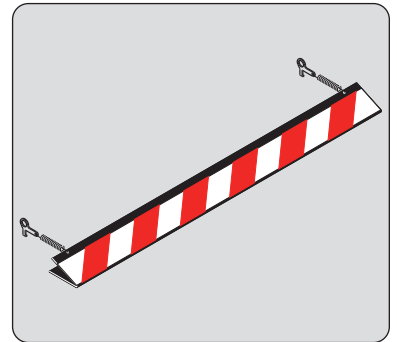

MANURE FORK GUARD

REFERENCE 230689

