



647567 EN 03/09/2024

MAN'GO 12

AUSTRALIA

OPERATOR'S MANUAL
(ORIGINAL MANUAL)

INITIAL VERSION

12/10/2015

UPDATED

20/07/2021

03/09/2024

This brochure and all the information contained herein, including drawings, are the intellectual property of Manitou BF and/or its subsidiaries (hereinafter "Manitou Group") and are confidential. Any reproduction, publication or communication to third parties of all or part of the brochure without the express written consent of Manitou Group is strictly prohibited. Any violation will subject you to legal action. The logos and visual identity of the company are the property of Manitou Group and may not be used without express formal authorization. All rights reserved.

All trademarks mentioned, whether registered or not, are and shall remain the property of MANITOU BF or its owner respectively.

Any reproduction, source code access, decompilation, modification, copy (other than backup copies), correction of errors, transmission or distribution of any software built into Manitou Group machines is strictly prohibited.

In the event that the measures above nevertheless prove essential to enable use of the software, in accordance with its destination, or to obtain the information required for interoperability with other software created independently, the user should contact Manitou Group in advance and may, at its sole discretion, take the necessary measures or give access to only the information strictly necessary for interoperability.

Any breach of these requirements is likely to constitute a counterfeiting offense subject to legal action by Manitou Group.

Connected Manitou Group machines are equipped with boxes that collect technical data on the machines (such as geo-tracking data or data on component operation). This data, which is organized, processed and enhanced by algorithms and expertise proprietary to Manitou Group, constitutes, whether or not in conjunction with other independent elements, a protected database under applicable intellectual property laws and regulations.

It is strictly forbidden to have access to all or part of this database and to use the data (including in the event of accidental access) without explicit prior authorization from Manitou Group. In the event that Manitou Group authorizes a Manitou Group machine user to access all or part of this database, Manitou Group, as producer of this database, cedes to the user only a right to personal, non-exclusive, nontransferable use of the database, and only by access to an information technology platform hosted by a server owned or controlled by Manitou Group.

In any case, the following are strictly prohibited:

- any extraction, reproduction, representation, reuse through provision to the public, distribution, transfer, permanent or temporary, on any medium, by any means, and in any form whatsoever, of all or of a qualitatively or quantitatively substantial part of the contents of this database,*
- any extraction, reproduction, representation, reuse through provision to the public, distribution, transfer, repeated or systematic of qualitatively or quantitatively insubstantial parts of the content of the database during operations manifestly exceeding normal use of the database by the user of the machine for his own needs,*
- any use of means to bypass technical protection measures for databases or the software source code embedded in the boxes, in accordance with the applicable intellectual property laws and regulations.*

The latest applicable version of this document is available upon request.

Only the computerized version is managed.

MANITOU BF S.A. Public limited company with a board of directors.

Head office: 430 rue de l'Aubinière - 44150 Ancenis - France

Share capital: €39,548,949

Entered in the Nantes Trade and Companies Register under number 857 802 508.

Tel.: +33 (0) 2 40 09 10 11

www.manitou.com

FOREWORD

ABOUT THIS OPERATOR'S MANUAL

This operator's manual forms an integral part of this machine and must be kept in the platform's storage compartment at all times.

MANITOU reserves the right to change its models and their equipment without notice. Contact MANITOU for up-to-date information.

This operator's manual provides operators with all the information relating to the safety precautions, usage instructions and maintenance procedures to ensure safe and reliable use of this machine.

Carefully read and understand this operator's manual before operating this machine.

This manual has been produced based on the equipment list and technical specifications given at the time of its design. The level of equipment depends on the options chosen and the country of sale.

According to the options and the date of sale, certain items of equipment/functions described in this operator's manual may not be present on the machine.

Descriptions and illustrations are non binding.

ANTICIPATED USE

This machine is a mobile aerial work platform of the type 3b designed to transport and lift personnel and their tools and equipment to a workplace at height.

MANITOU has ensured that this machine is suitable for use in the standard operating conditions defined in this operator's manual.

TECHNICAL INFORMATION BULLETINS

The safety of the machine and personnel is essential for MANITOU. The technical information bulletins are written to communicate important safety information, intended for dealers, owners and users of the machine.

This machine must comply with all the relevant technical information bulletins. Contact MANITOU or your dealer to get information on the bulletins concerning your machine.

These technical information bulletins are sent to the owners of the machine. As a result, it is very important to register your machine and ensure that the information is accurate and up to date.

In the event of transfer of ownership of the machine, update the information to guarantee that the technical information bulletins are sent to the new owner.

CONTACT THE MANUFACTURER

You should contact MANITOU in the following scenarios:

- To report an accident.
- To update information about the current owner.
- For questions about compliance with standards and regulations.
- For questions about machine use and safety.
- For questions about any special application or any modification of the product.

MANITOU BF SA Public limited company with a board of directors.

Head office: 430 rue de l'Aubinière - 44150 Ancenis - France

Share capital: 39 548 949 €

857 802 508 RCS Nantes

Tel.: +33 (0) 2 40 09 10 11

www.manitou.com

WARNINGS AND SAFETY INSTRUCTIONS

The following safety alert is used in this manual to warn you of the risks during use or maintenance of this machine:



Follow the safety instructions following this warning to avoid any risk of injury, death or equipment damage.

MACHINE IDENTIFICATION

The machine's identification plate is riveted on the back of the chassis. The following information is engraved on it:

1 PLATFORM MANUFACTURER'S PLATE

Designation	
Year of manufacture	
Model year	
Unladen mass	
Nominal power	
Voltage	
Inside / Outside	
Maximum load	
Maximum number of persons	
Mass of equipment	
Manual forces	
Maximum inclination	
Maximum wind speed	
Serial Number	

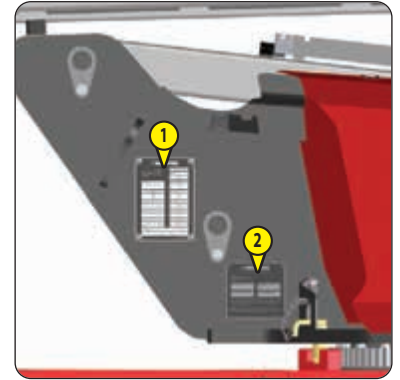

2 EWP ADDITIONAL INFORMATION PLATE

Model	
Serial No.	
Date of commission	
Design registration No.	

Note: commercial names are used in this operator's manual in order to make it easier to read.

MAN GO 12

Commercial name: MAN'GO 12



SECTIONS

1 - OPERATING AND SAFETY INSTRUCTIONS

2 - DESCRIPTION

3 - MAINTENANCE

1 - OPERATING AND SAFETY INSTRUCTIONS

1 - OPERATING AND SAFETY INSTRUCTIONS

INSTRUCTIONS TO THE COMPANY MANAGER

1-4

THE SITE	1-4
THE OPERATOR	1-4
THE MACHINE	1-4
A - SUITABILITY OF THE MACHINE FOR THE TASK	1-4
B - ADAPTING THE MACHINE TO USUAL ENVIRONMENTAL CONDITIONS	1-5
C - MODIFYING THE MACHINE	1-5
INSTRUCTIONS	1-5
MAINTENANCE	1-5

INSTRUCTIONS FOR THE OPERATOR

1-6

INTRODUCTION	1-6
GENERAL INSTRUCTIONS	1-6
A – OPERATOR'S MANUAL	1-6
B - AUTHORISATION FOR USE IN FRANCE	1-6
C - MAINTENANCE	1-7
D - MODIFYING THE MACHINE	1-7
E - GROUND LINK	1-7
F - SAFETY DEVICES	1-7
OPERATING INSTRUCTIONS	1-8
A - BEFORE USING THE MACHINE	1-8
B - DRIVER'S CAB LAYOUT	1-8
C - ENVIRONMENT	1-9
D - VISIBILITY	1-17
E - STARTING MACHINES WITH A DIESEL ENGINE	1-17
F - SWITCHING ON ELECTRICAL MACHINES	1-17
G - DRIVING THE MACHINE	1-17
H - SHUTTING DOWN THE MACHINE	1-18
INSTRUCTIONS FOR WELDING AND BLOW TORCH WORK ON AN EXTERNAL STRUCTURE	1-19
A - WITH AN ELECTRICAL WELDING SET	1-19
B - WITH A BLOW TORCH	1-19

MACHINE MAINTENANCE INSTRUCTIONS

1-20

GENERAL INSTRUCTIONS	1-20
MAINTENANCE	1-20
MAINTENANCE LOGBOOK	1-20
LUBRICANT AND FUEL LEVELS	1-20
HYDRAULICS	1-20
ELECTRICITY	1-21
TILT SENSOR	1-21
WELDING ON THE MACHINE	1-21
WASHING THE MACHINE	1-21

IF THE MACHINE IS NOT TO BE USED FOR A LONG TIME **1-22**

INTRODUCTION 1-22

PREPARATION OF THE MACHINE 1-22

MACHINES WITH A DIESEL ENGINE: ENGINE PROTECTION 1-22

ELECTRICAL MACHINES: BATTERY CHARGE 1-22

PROTECTING THE MACHINE 1-22

BRINGING THE MACHINE BACK INTO SERVICE. 1-23

DISPOSING OF THE MACHINE **1-24**

RECYCLING OF MATERIALS. 1-24

METALS 1-24

PLASTICS 1-24

RUBBER 1-24

GLASS 1-24

ENVIRONMENTAL PROTECTION. 1-24

WORN OR DAMAGED PARTS 1-24

USED OIL 1-24

USED BATTERIES. 1-24

INSTRUCTIONS TO THE COMPANY MANAGER

THE SITE

Proper management of the machine's area of travel will reduce the risk of accidents:

- Ground not unnecessarily uneven or obstructed.
- No excessive slopes.
- Pedestrian traffic controlled, etc.

THE OPERATOR

⚠ IMPORTANT ⚠

Only qualified, authorised personnel can use this machine.

This authorisation is given in writing by the appropriate person in the establishment with respect to the use of machine and must be carried permanently by the operator.

⚠ IMPORTANT ⚠

On the basis of experience, there are a number of possible situations in which operating the machine is contra-indicated.

Such foreseeable abnormal uses, the main ones being listed below, are strictly forbidden:

- *The foreseeable abnormal behaviour resulting from ordinary negligence, but which does not result from any wish to put the machinery to any improper use.*
 - *The reflex reactions of a person in the event of a malfunction, incident, fault, etc. during operation of the machine.*
 - *Behaviour resulting from application of the "principle of least effort" when performing a task.*
- *The foreseeable behaviour of such persons as: apprentices, teenagers, handicapped persons, trainees tempted to drive a machine, operators tempted to operate a machine to win a bet, in competition or for their own personal experience.*
 - *The person in charge of the establishment must take these criteria into account when assessing the suitability of a person to drive.*

⚠ IMPORTANT ⚠

OBTAIN INFORMATION ON:

- *How to behave when there is a fire.*
- *The location of the nearest first aid kit and fire extinguisher.*
- *The emergency telephone numbers for calling (the doctors, ambulance, hospital and fire brigade).*

THE MACHINE

A - SUITABILITY OF THE MACHINE FOR THE TASK

- MANITOU has ensured that this machine is suitable for use under the standard operating conditions defined in this operator's manual, with an **OVERLOAD TEST COEFFICIENT OF 1.25** and an **OPERATIONAL TEST COEFFICIENT OF 1.1**, as stipulated in harmonised standard **EN 280** for **MEWPs** (Mobile Elevating Work Platforms).
- Before commissioning, the company manager must make sure that machine is appropriate for the work to be done, and perform certain tests (in accordance with current legislation).

B - ADAPTING THE MACHINE TO USUAL ENVIRONMENTAL CONDITIONS



For operation under average climatic conditions, i.e.: between -15 °C and +35 °C, lubricants are topped up in the factory.

For operation under more severe climatic conditions, before starting up, it is necessary to drain all the circuits, then ensure correct levels of lubricants using lubricants properly suited to the relevant ambient temperatures. The same applies to coolant.



Machines with diesel engines are designed for outdoor use under normal atmospheric conditions and indoor use in suitably aerated and ventilated premises.

Electrical machines are designed for outdoor use under normal atmospheric conditions and for indoor use.

It is prohibited to use the machine in areas where there is a risk of fire or which are potentially explosive (e.g. refineries, fuel or gas depots, stores of inflammable products, etc.).

For use in these areas, specific equipment is available, consult your dealer.

- In addition to standard equipment mounted on your machine, many options are available, such as: rotating beacon light, worklight, etc. Contact your dealer.
- Take the climate and atmospheric conditions of the site of use into account. Consult your dealer for adapting the lubricants and frost protection.
- Prevent fire risks associated with use in dusty and flammable conditions.
- A machine operating in an area without fire extinguishing equipment must be equipped with an individual extinguisher. Solutions are available, consult your dealer.

C - MODIFYING THE MACHINE



It is strictly prohibited to replace machine components with components not approved by Manitou (batteries, wheels, platform, etc.).



It is strictly forbidden to change the structure and settings of the various components of your machine (hydraulic pressure, calibrating limiters, engine speed, sensors, addition of extra equipment, addition of counterweight, unapproved attachments, alarm systems, etc.) yourself. In this event, the manufacturer cannot be held responsible.



Risk of the machine becoming unstable:

- *Depending on the model, your machine may be supplied with standard wheels or all-terrain wheels. It is PROHIBITED to change from one type of wheel to the other.*
- *ELECTRICAL MACHINES: it is prohibited to replace the batteries with lighter batteries.*

INSTRUCTIONS

- The instruction manual should always be in good condition, in the operator's language and placed in the platform storage compartment.
- You must replace the instruction manual, as well as any plates or stickers, if they are no longer legible or are missing or damaged.

MAINTENANCE



Refer to chapter: MACHINE MAINTENANCE INSTRUCTIONS.



Your machine must be periodically inspected to ensure its continued compliance.

The inspection frequency is defined by the legislation in force in the country in which the machine is used.

- Maintenance or repairs other than those detailed in section 3 - MAINTENANCE must be carried out by qualified personnel (consult your dealer) and under the necessary safety conditions to maintain the health of the operator and any third party.
- Example for France: the manager in charge of the establishment using a machine must open and maintain a maintenance log for each machine (order of 2 March 2004).

INSTRUCTIONS FOR THE OPERATOR

INTRODUCTION

⚠ IMPORTANT ⚠

The risk of accident while using, servicing or repairing this machine can be reduced if you follow the safety instructions and preventive measures detailed in these instructions.

Failure to respect the safety and operating instructions, or the instructions for repairing or servicing this machine may lead to serious, even fatal accidents.

- Only the operations and manoeuvres described in this operator's manual must be performed. The manufacturer cannot predict all possible risky situations. Consequently, the safety instructions given in the operator's manual and on the machine itself are not exhaustive.
- As an operator, you must at all times give reasonable consideration to the possible risks to yourself, to others or to the machine itself when you use it.

GENERAL INSTRUCTIONS

A – OPERATOR'S MANUAL

⚠ IMPORTANT ⚠

Carefully read and understand this instruction manual before using this machine.

- The instruction manual should always be in good condition, in the operator's language and placed in the platform storage compartment.
- You must replace the instruction manual, as well as any plates or stickers, if they are no longer legible or are missing or damaged.
- Any operations or manoeuvres not described in the operator's manual are forbidden.
- Follow the safety advice and the instructions on the machine's stickers.
- As a safety precaution, a user must be present on the ground when the machine is in use.
- Familiarise yourself with the machine on the terrain where it will be used.
- The machine must also be used in accordance with good engineering practice.
- Do not use the machine if the wind speed is over 45 km/h (12.5 m/s).
- Do not push or pull similar structures or elements off the platform. The maximum manual force is indicated in 2 - INSTRUCTIONS: SPECIFICATIONS and on 1 or more stickers located in the platform.
- Machines intended exclusively for indoor use must not be used outside the buildings.

B - AUTHORISATION FOR USE IN FRANCE

(or see current legislation in other countries).

- This machine is not type-approved for driving on public roads.
- Only qualified, authorised personnel can use the machine. This authorisation is given in writing by the appropriate person in the establishment where the machine is to be used and must be carried permanently by the operator.
- The operator is not empowered to authorise the driving of the machine by another person.

C - MAINTENANCE

⚠ IMPORTANT ⚠

Do not use the machine if the wheels are damaged or excessively worn, because this could put your own safety or that of others at risk, or cause damage to the machine itself.

⚠ IMPORTANT ⚠

For electrical machines, the operator must ensure that:

- Safety goggles are always worn when charging the batteries.

- The batteries are not charged in an explosive environment.

- There is no smoking and no naked flame directed towards the batteries when they are being handled (removal/installation) and when monitoring filling levels.

- Do not leave the battery charger connected during a lightning storm.

- The operator must carry out the daily maintenance (↖ 3 - MAINTENANCE) before using the machine in his place of work.
- The operator must immediately advise his superior if his machine is not in good working order or does not comply with the safety notice.
- The operator is prohibited from carrying out any repairs or adjustments himself, unless he has been trained for this purpose. He must keep the machine properly cleaned if this is among his responsibilities.
- The operator is responsible for deciding and adjusting the frequency of cleaning needed to prevent the risk of fire ensuing from the build-up of flammable material. The operator should pay special attention to all the areas of the machine where these risk materials are likely to accumulate.
- The operator must ensure that the wheels are appropriate for the type of ground (see the ground contact area of the wheels ↖ 2 - DESCRIPTION: SPECIFICATIONS). Optional solutions are available, consult your dealer.

D - MODIFYING THE MACHINE

- ↖ INSTRUCTIONS TO SITE MANAGER: ↖ C - MODIFYING THE MACHINE.

E - GROUND LINK

- MACHINES WITHOUT OSCILLATING AXLE (ACCORDING TO MODEL)

⚠ IMPORTANT ⚠

The frame is rigid, so the machine can bear on only three wheels.

- MACHINES WITH OSCILLATING AXLE (ACCORDING TO MODEL)

⚠ IMPORTANT ⚠

The oscillating axle enables the machine to bear on four wheels when in transport position (within the limits of the axle's oscillation).

When moving in the working position, the oscillating axle is locked (the frame is stiff) so the machine may bear on only three wheels.

F - SAFETY DEVICES

- This machine is fitted with special safety devices that are able to limit its operation as circumstances require (↖ 2 - DESCRIPTION):
 - Excessive load in the platform.
 - Tilting of the frame beyond the authorised limits.
 - Blocking of the oscillating axle (according to model).
 - Slack or broken telescope cable (according to model).

OPERATING INSTRUCTIONS

A - BEFORE USING THE MACHINE

- Perform the daily maintenance (☞ 3 - MAINTENANCE).

B - DRIVER'S CAB LAYOUT

- Whatever their experience, operators are advised to familiarise themselves with the position and operation of the control panels before putting the machine into operation.
- Do not get into or out of the platform until it is fully lowered.
- Always get into and out of the platform through the gate or using the sliding mid-rails (depending on the model).
- Always get in and out of the platform facing into the platform.
- Always use both hands and one foot or both feet and one hand to get in and out of the platform.
- Make sure that the sliding mid-rails (depending on the model) are in the low position and that the the gate is closed properly (depending on the model) before using this machine.
- Do not attach the sliding mid-rails in the high position.
- MANITOU strongly recommends wearing a safety harness attached to a lashing point in the platform, ☞ 2 - DESCRIPTION. Wearing a safety harness or other personal fall protection may be mandatory, comply with the local, government and national regulations in force, the employer's safety rules and the rules for work sites.
- The safety harness or other personal fall protection must comply with the local, government and national regulations in force. They must be inspected in accordance with the regulations in force.
- Safety helmets must be worn.
- Wear suitable clothing for driving the machine; do not wear baggy clothes.
- Never operate the machine when hands or feet are wet or soiled with greasy substances.
- Make sure you have the appropriate protective equipment for the job to be done.
- Prolonged exposure to high noise levels may cause hearing problems. It is recommended to wear ear muffs to protect against excessive noise.
- Remain alert at all times when using the machine. Do not listen to the radio or music using headphones or earphones.
- The operator must always be in the normal operator's position. It is prohibited to have arms or legs, or generally any part of the body, protruding from the platform.
- The control units must never in any event be used for any other than their intended purposes (e.g. for getting in or out of the platform, as a coat hook, etc.).
- The machine must not be fitted with unauthorised attachments that increase the unit's wind load.
- Do not use ladders or improvised structures in the platform to gain extra height.
- Do not climb onto the platform railings to gain extra height.

C - ENVIRONMENT

⚠ IMPORTANT ⚠

If the platform must remain stationary over a structure for a long period, there is a risk that the platform will descend and rest on this structure because of the oil cooling in the cylinders or a minor leak in the cylinder locking system. To eliminate this risk:

- Regularly check the distance between the platform and the structure and readjust if necessary.
- If possible use the machine at an oil temperature as close as possible to ambient temperature.

⚠ IMPORTANT ⚠

It is forbidden to use the machine close to electricity cables. Maintain the specified safe distances, refer to 5.8 WORKING IN PROXIMITY TO AERIAL CONDUCTORS (OVERHEAD POWER LINES) on the next pages.

You must consult your local electrical agency.

You could be electrocuted or seriously injured if you operate or park the machine too close to power cables.

If the machine comes into contact with electrical cables, press the Emergency Stop button.

Call for help, warn people on the ground not to touch the machine, and ask them to switch off or get somebody to switch off the power supply to the cables.

⚠ IMPORTANT ⚠

Do not use this machine during lightning storms, snow storms, during frosty periods or in hazardous weather conditions. In case of strong wind exceeding 45 km/h, do not make any movement that may endanger the machine's stability.

- Comply with site safety regulations.
- The machine can be manoeuvred from the ground: ensure that you forbid access.
- If you have to use the machine in a dark area or at night, make sure it is equipped with working lights.
- The machines may not be used as cranes or elevators for the permanent transport of people or materials, nor as jacks or supports.
- Suspending a load under the platform or on any part of the lifting apparatus is strictly forbidden.
- When operating, ensure that there is no one or anything impeding the machine's progress and operation.
- When raising the platform, ensure that nothing/nobody is impeding the machine's operation and do not perform any inappropriate manoeuvres.
- Do not allow anybody to come near the working area of the machine or pass beneath the lifting structure or beneath the platform. To ensure this, mark out your working area.
- Driving on a slope:
 - Adjust the machine speed with the proportional control handle.
 - Make sure that the slope is not steeper than the maximum slope for the machine (≤ 2 - DESCRIPTION).
- Take into account the machine's dimensions and its load before trying to negotiate a narrow or low passageway.
- Never move onto loading ramps without having first checked:
 - That they are suitably positioned and made fast.
 - That the vehicle to which it is connected (trailer, wagon, etc.) cannot move.
 - That they are suitable for the size and weight of the machine (≤ 2 - DESCRIPTION).
 - That the slope is not steeper than the maximum slope for the machine (≤ 2 - DESCRIPTION).
- Never move onto a foot bridge, floor or freight lift without being certain that they are suitable for the size and weight of the machine and without having checked that they are in sound working order.
- Be careful in the area of loading bays, trenches, scaffolding, soft ground, manholes, etc.
- Make sure the ground is stable and firm under the wheels and/or stabilisers before lifting the platform. If necessary, add sufficient wedging under the stabilisers.
- Do not attempt any operations outside the machine's capabilities.
- Ensure that any equipment and materials loaded onto the platform (pipes, cables, containers, etc.) cannot fall out. Do not pile this equipment and these materials to the point where it is necessary to step over them.

- Keep all body parts, conductive objects or parts of the machine a safe distance from power lines or live components, unless the local, government and national regulations in force, the employer's safety rules or the rules for work sites are stricter in terms of the distance required.
- Take into account the movement of the platform and the swinging or sagging of the power lines.
- To visually recognise the wind speed, refer to the empirical wind evaluation scale:

BEAUFORT scale (wind speed at a height of 10 m on a flat site)						
Force	Type of wind	Speed (knots)	Speed (km/h)	Speed (m/s)	Effects on Land	Sea conditions
0	Calm	0 - 1	0 - 1	<0.3	Smoke rises vertically.	Sea is like a mirror.
1	Light air	1 - 3	1 - 5	0.3 - 1.5	Smoke indicates direction of wind.	Ripples with appearance of scale, no foam crests.
2	Light breeze	4 - 6	6 - 11	1.6 - 3.3	Wind felt on face, leaves rustle.	Short wavelets, but pronounced.
3	Gentle breeze	7 - 10	12 - 19	3.4 - 5.4	Leaves and small twigs in constant motion.	Very small waves, crests begin to break.
4	Moderate breeze	11 - 16	20 - 28	5.5 - 7.9	Wind raises dust and loose pieces of paper; small branches are moved.	Small waves, becoming longer, numerous whitecaps.
5	Fresh breeze	17 - 21	29 - 38	8 - 10.7	Small trees in leaf begin to sway.	Wavelets form on inland waters; moderate waves, taking longer form.
6	Strong breeze	22 - 27	39 - 49	10.8 - 13.8	Large branches in motion, whistling heard in overhead wires, umbrella use becomes difficult.	Larger waves forming, whitecaps everywhere, some spray.
7	Near gale	28 - 33	50 - 61	13.9 - 17.1	Whole trees in motion, inconvenience felt when walking against the wind.	Sea heaps up; white foam from breaking waves begins to be blown in streaks along the direction of the wind.
8	Gale	34 - 40	62 - 74	17.2 - 20.7	Wind breaks twigs off trees; impedes progress.	Moderately high waves of greater length; edges of crests begin to break into spindrift.
9	Strong gale	41 - 47	75 - 88	20.8 - 24.4	Wind damages roofs (chimneys, slates, etc.).	High waves, crests of waves begin to topple, streaks of foam; reduced visibility.
10	Storm	48 - 55	89 - 102	24.5 - 28.4	Seldom experienced inland; trees uprooted; considerable structural damage occurs.	Very high waves; white streaks of foam; reduced visibility.
11	Violent storm	56 - 63	103 - 117	28.5 - 32.6	Very rare, widespread damage.	Exceptionally high waves able to hide medium sized ships from view, reduced visibility.
12	Hurricane	64 +	118 +	32.7 +	Devastating damage.	Sea completely white; air filled with foam and spray, very reduced visibility.

NOTE: The following chapter 5.8 is reproduced from AS2550.10—2006 Standard

5.8 WORKING IN PROXIMITY TO AERIAL CONDUCTORS (OVERHEAD POWER LINES)

5.8.1 General

Clause 5.8 refers to hazards and risks presented by the operation of MEWPs in the vicinity of overhead electrical conductors.

NOTES:

- 1 Occupational Health and Safety authorities and electricity supply bodies in each State may have issued guidelines for the use of cranes and other plant in the vicinity of overhead conductors.
- 2 A conservative approach has been adopted. Separation distances have not been determined based purely on electrical voltages of conductors, nor whether the conductor is bare or insulated. The distances were chosen based on experience and practical considerations, since MEWPs cannot be operated as accurately as arcing distances can be calculated.

Before setting the MEWP into operational configuration, a check for the presence of overhead conductors and power lines shall be undertaken.

Throughout Clause 5.8, the following definitions apply:

- (a) *Aerial conductor*—an overhead conductor that is either insulated or bare.
- (b) *Operation*—where any MEWP components are moved or about to be moved from their transport configuration and in the instance of MEWPs having stabilizers, where stabilizers are moved or about to be moved from their transport configuration.
- (c) *Overhead power line*—aerial conductors and other parts that make up an aerial line for the distribution and transmission of electrical energy.
- (d) *Electricity distributor*—the power supply authority, transmission line operator, generator, traction company or distribution company.

All aerial conductors shall be treated as live unless documentary evidence that the conductors have been positively de-energized, isolated or earthed has been received from the electricity distributor or transmission line operator.

Where such documentary evidence has been made available, it shall state the date and time frame of isolation and any special conditions and precautions. The MEWP shall not be operated in contravention of this documentary information.

5.8.2 Precautions when operating near live aerial conductors

The MEWP shall only be operated within close proximity of live aerial conductors, if the separation distances appropriate to the 'NO-GO-ZONE' or 'SPOTTER-REQUIRED ZONE', and risk controls given in Clause 5.8.3, are maintained.

A site-specific risk assessment shall be completed before the commencement of the job by a trained and competent person. This assessment shall be verified immediately before work commences, and its relevance monitored during the job. If initial circumstances change, work shall cease until an appropriate risk assessment is undertaken.

Where a spotter is required to inform the operator in the event of the MEWP approaching the zone boundaries shown, the following applies:

- (a) The spotting operation shall be carried out by a competent person.
NOTE: Required competency levels may be defined by the applicable State authority.
- (b) The spotter shall be positioned so that the exposure to hazards is eliminated or minimized.
- (c) The spotter shall be able to clearly observe the separation distances.
- (d) The spotter shall not undertake any other work whilst performing spotting duties.
- (e) The spotter shall be specifically instructed in the workplace hazards applicable to the site.
- (f) The spotter shall be able to communicate with the MEWP operator at all times during erection, operation and dismantling.

5.8.3 Separation distances and risk controls

Where possible, the zone separation distances should be not less than those shown in Figure 5.8.3.

NOTE: The separation distances shown in Figure 5.8.3 include allowance for sag and sway of line(s) due to the effects of wind and temperature.

Where the separation distances cannot be achieved, the electricity distributor shall be notified in writing. The MEWP shall not be operated within the 'no go zone' until the applicable requirements below are satisfied.

When operating in the vicinity of aerial conductors, the separation distance between the MEWP and aerial conductor and risk controls shall comply with the following:

- (a) *Overhead power lines (up to and including 133 kV)* The following applies:
- (i) *Spotter required zone* The MEWP shall not be operated in the 'spotter required zone' as indicated in Figure 5.8.3 for overhead power lines up to and including 133 kV, unless—
- (A) the electricity distributor is notified before commencing work;
 - (B) written permission from the electricity distributor has been obtained;
 - (C) the MEWP is insulated in accordance with the requirements of AS 1418.10(Int.);
 - (D) a spotter performs spotting duties;
 - (E) a pre-start site/job meeting has been convened and a risk assessment completed; and
 - (F) the MEWP is equipped with one controlled descent device located at the platform or basket for each occupant, and each occupant is trained and experienced in its use.
- NOTE: The controlled descent device is not an emergency retrieval device.
- (ii) *No go zone* The MEWP shall not be operated in the 'no go zone' as indicated in Figure 5.8.3 for overhead power lines up to and including 133 kV, unless—
- (A) the electricity distributor is notified before commencing work;
 - (B) written permission from the electricity distributor has been obtained;
 - (C) all conditions specified by the electricity distributor are complied with;
 - (D) the MEWP is insulated in accordance with the requirements of AS 1418.10(Int.);
 - (E) a spotter performs spotting duties;
 - (F) a pre-start site/job meeting has been convened and a risk assessment completed; and
 - (G) the MEWP is equipped with one controlled descent device located at the platform or basket for each occupant, and each occupant is trained and experienced in its use.
- NOTE: The controlled descent device is not an emergency retrieval device.
- (b) *Overhead power lines (greater than 133 kV)* The following applies:
- (i) *Spotter required zone* The MEWP shall not be operated in the 'spotter required zone' as indicated in Figure 5.8.3 for overhead power lines greater than 133 kV, unless—
- (A) written permission from the electricity distributor has been obtained;
 - (B) an easement entry permit has been provided by the electricity distributor;
 - (C) a spotter performs spotting duties;
 - (D) a pre-start site/job meeting has been convened and a risk assessment completed;
 - (E) the MEWP is insulated in accordance with the requirements of IEC61057 or ANSI/SIA A92.2; and
 - (F) the MEWP is equipped with one controlled descent device located at the platform or basket for each occupant, and each occupant is trained and experienced in its use.
- NOTE: The controlled descent device is not an emergency retrieval device.

- (ii) *No go zone* The MEWP shall not be operated in the 'no go zone' as indicated in Figure 5.8.3 for overhead power lines greater than 133 kV, unless—
- (A) an easement entry permit has been provided by the electricity distributor;
 - (B) written permission from the electricity distributor has been obtained;
 - (C) all conditions specified by the electricity distributor are complied with;
 - (D) the electricity distributor is notified before commencing work;
 - (E) a spotter performs spotting duties;
 - (F) a pre-start site/job meeting has been convened and a risk assessment completed;
 - (G) the MEWP is insulated in accordance with the requirements of IEC61057 or ANSI/SIA A92.2; and
 - (H) the MEWP is equipped with one controlled descent device located at the platform or basket for each occupant, and each occupant is trained and experienced in its use.
- NOTE: The controlled descent device is not an emergency retrieval device.

- (iii) *Spotter required zone* The MEWP shall not be operated in the 'spotter required zone' as indicated in Figure 5.8.3 for overhead power lines greater than 133 kV, unless—
- (A) written permission from the electricity distributor has been obtained;
 - (B) an easement entry permit has been provided by the electricity distributor;
 - (C) a spotter performs spotting duties;
 - (D) a pre-start site/job meeting has been convened and a risk assessment completed;
 - (E) the MEWP is insulated in accordance with the requirements of IEC61057 or ANSI/SIA A92.2; and
 - (F) the MEWP is equipped with one controlled descent device located at the platform or basket for each occupant, and each occupant is trained and experienced in its use.
- NOTE: The controlled descent device is not an emergency retrieval device.

- (c) *Public transport authorities* Where aerial conductors are dedicated to the use of public transport authorities (e.g. tramways and railways), the separation distance shall be the same as that for aerial conductors up to and including 133 kV (see Item (a)).
- (d) *Downshop conductors* Before mobile machinery is set up for operation in the vicinity of downshop conductors, the power supply to the conductors shall be isolated unless appropriate control measures have been developed and implemented.

NOTES:

- 1 Downshop conductors (e.g. collector rails), should be clearly identified.
- 2 Clearances from downshop conductors should be in accordance with AS/NZS 3000.

- (e) *Barriers at ground level* Where people not involved in the operation could otherwise come into the area of possible voltage step potential, barriers shall be provided at ground level to prevent this from occurring. Appropriate warning signs shall be displayed on the barriers. Pedestrians should be barricaded from the area of possible voltage step potential (see Figure 5.8.4) in the vicinity of the MEWP and associated equipment.
- (f) *Earthing systems* An appropriate earthing system shall be fitted to the MEWP and shall be in use. Operators and those working in proximity to the MEWP shall be advised of the limits of the effectiveness of the earthing equipment.
- (g) *High visibility bunting* Where high visibility bunting, for example 'tiger tails' is applied to the conductors, it shall be regarded as a visual indicator only and not as insulation.

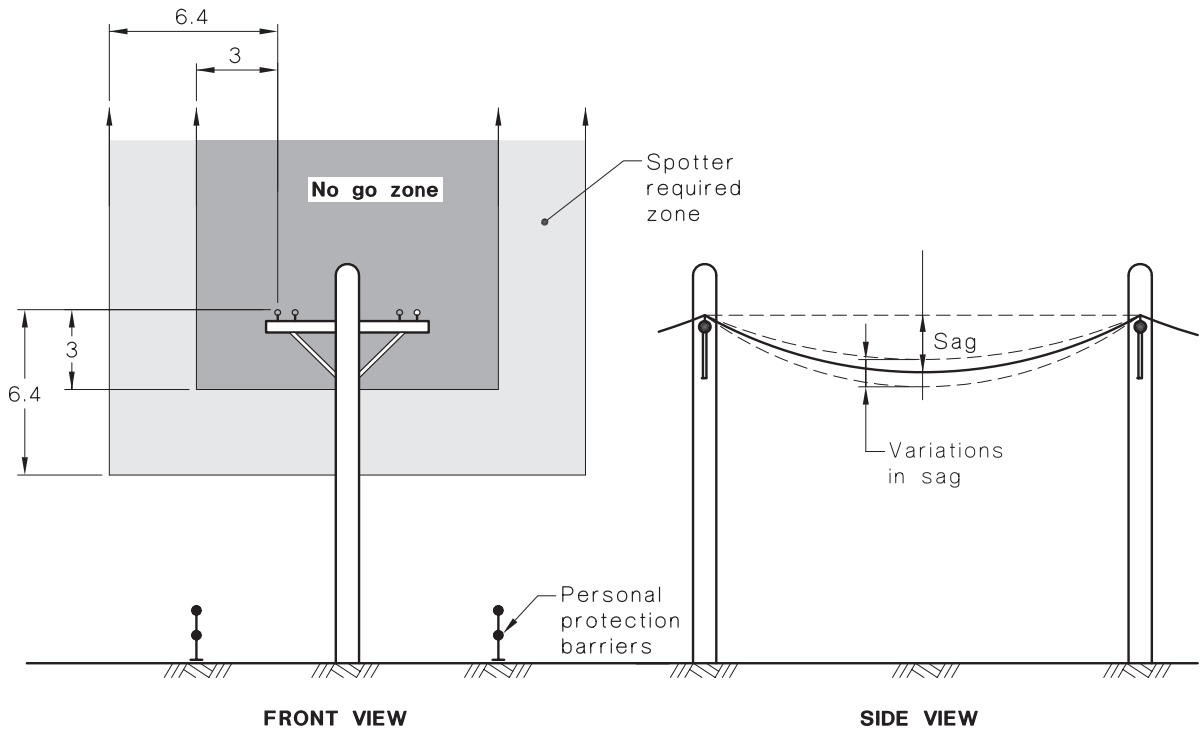

(a) Distribution lines up to and including 133 kV

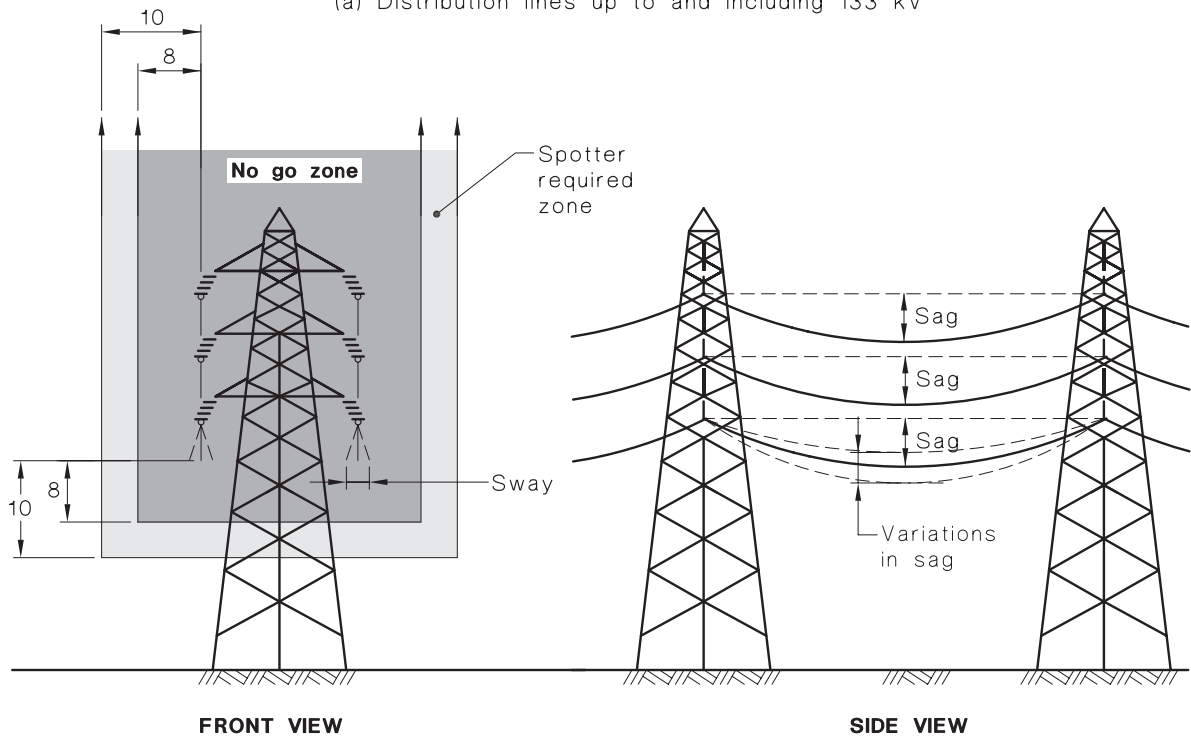

(b) Transmission lines greater than 133 kV

LEGEND:

- = No shading, in the front views, indicates no proximity requirements
- = Light shading indicated spotter is required
- = Heavy shading indicates the NO GO ZONE

DIMENSIONS IN METRES

FIGURE 5.8.3 CLEARANCES FROM LIVE AERIAL CONDUCTORS

5.8.4 Aerial conductors contact

If the MEWP or load contacts aerial conductors, the relevant electricity distributor shall be immediately notified of the situation and, until assistance is received, a competent person shall remain in a prominent position to warn of the danger of electrocution.

In such an event the MEWP operator should act as follows:

- (a) Remain on the MEWP.
- (b) Warn all other personnel to keep away from the MEWP and not touch any part of the MEWP.
- (c) Without anyone approaching the MEWP, operate the MEWP in such a manner to break contact, where possible.
- (d) When unable to move or disentangle the MEWP from the aerial conductors, remain on the MEWP and take no further action until it is confirmed that conditions are safe.
- (e) Only when it is essential to leave the MEWP because of fire or some other reason, to avoid being electrocuted, the following actions should be taken:
 - (i) For personnel on the chassis of the vehicle, jump clear as far away from the MEWP as possible and avoid touching the MEWP and the ground at the same time. When moving away from the MEWP, shuffle or hop slowly across the affected area to avoid a simultaneous contact across areas of high potential difference (see Figure 5.8.4).
 - (ii) For personnel in the platform or basket, escape using a controlled descent device. When moving away from the MEWP, shuffle or hop slowly across the affected area to avoid a simultaneous contact across areas of high potential difference (see Figure 5.8.4).

Where the MEWP operator is immobilized, the power shall be isolated before assistance is given.

When a MEWP has been in contact with a live aerial conductor, it shall be withdrawn from service and checked by a competent person for any damage to its components. Any actions recommended by the competent person shall be completed before the MEWP is returned to service.

NOTE: AS 1418.10(Int) provides additional guidelines relating to inspection of MEWPs following contact with powerlines.

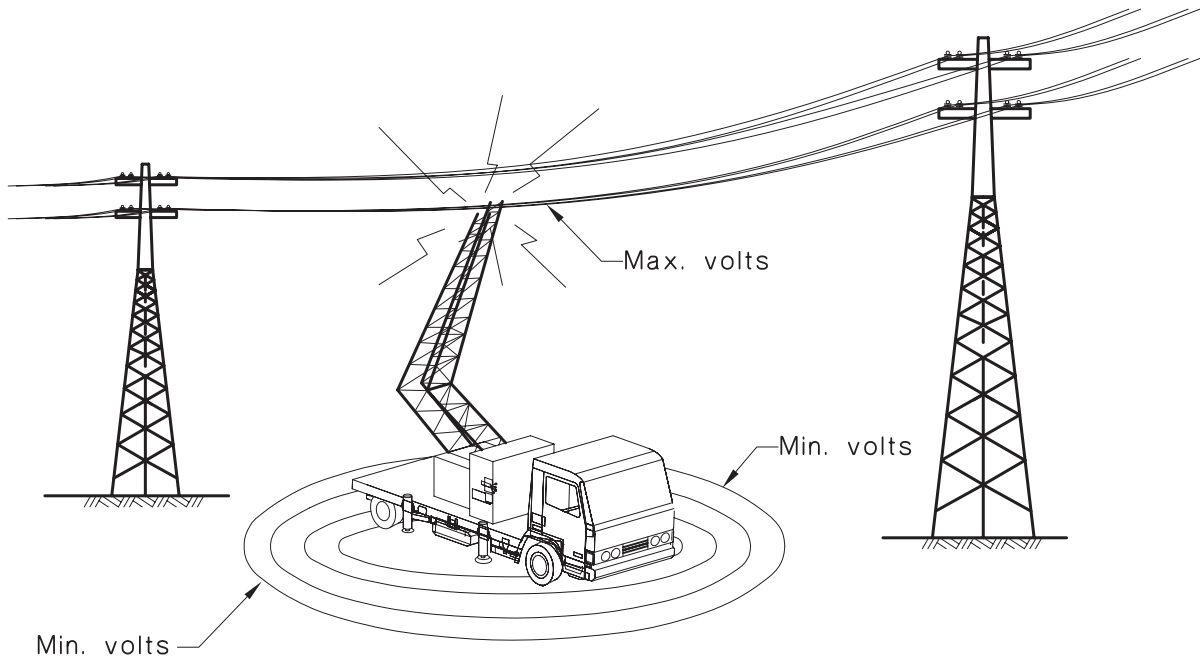

(a) Affected area

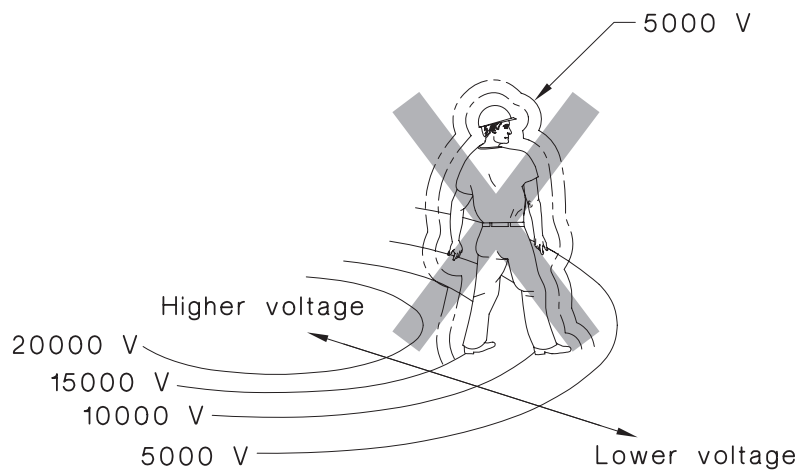

(b) Avoid simultaneous contact across areas of high potential difference

FIGURE 5.8.4 TYPICAL AFFECTED AREA SURROUNDING A MEWP WHEN IN CONTACT WITH A LIVE AERIAL CONDUCTOR

D - VISIBILITY

- Ensure good visibility of your route at all times. To increase your visibility, you can move forwards with the jib slightly raised (beware of the risk of falls in the platform from knocking into a low doorway, overhead electric wires, travelling cranes, road bridges, railway lines or any obstacle in the area in front of the machine). While reversing, look directly behind you. In any case, avoid reversing long distances.
- If visibility of your road is inadequate, ask someone to help, standing outside the area in which the machine will be moving, and make sure you always have a good view of this person.

E - STARTING MACHINES WITH A DIESEL ENGINE

⚠ IMPORTANT ⚠

Failure to respect polarity between batteries can cause serious damage to the electrical circuit.

The electrolyte in the battery may produce an explosive gas.

Avoid flames and generation of sparks close to the batteries. Never disconnect a battery while it is being charged.

- INSTRUCTIONS: 2 - DESCRIPTION.
- If using an emergency battery for start-up, use a battery with the same characteristics and respect battery polarity when connecting it. Connect the positive terminal first, and then the negative terminal.

F - SWITCHING ON ELECTRICAL MACHINES

- INSTRUCTIONS: 2 - DESCRIPTION
- Do not use the machine if the battery or batteries are discharged to the point that movements are slowed down. In certain cases, the machine may stop (2 - DESCRIPTION for the charge level not to be exceeded).

G - DRIVING THE MACHINE

⚠ IMPORTANT ⚠

Operators should be aware of the risks connected with using this machine, notably:

- Risk of losing control.

- Risk of the machine becoming unstable.

The operator must remain in control of the machine at all times.

- Do not attempt any operations outside the machine's capabilities.
- Familiarise yourself with the machine on the terrain where it will be used.
- Driving long distances should always be done with the machine in the transport position (2 - DESCRIPTION).
- Drive smoothly and adapt the machine's speed to the usage conditions (ground configuration, load in the platform, etc.). Depending on the machine model, select the appropriate speed for the usage conditions (2 - DESCRIPTION).
- Keep control of the speed in all circumstances.
- Ensure that the brakes work efficiently, taking into account the braking distances.
- Take extreme care when manoeuvring the machine with the platform raised. Ensure that there is sufficient visibility.
- Take bends slowly.
- Look where you are going and always make sure you have good visibility along the route.
- Drive round obstacles.
- Never drive on the edge of a ditch or steep slope.
- Travel slowly on damp, slippery or uneven terrain or on loading ramps.
- Machines with a diesel engine: never leave the engine running when the machine is unattended.
- Never leave the machine switched on during the operator's absence.
- Whatever your operating speed, you must reduce the speed as much as possible before stopping.
- The machine should be operated in an area free of any obstructions or danger when the platform is lowered to the ground.
- Pay attention to structures, objects and people when manoeuvring.
- The operator using the machine must be aided on the ground by a person with adequate training.
- Remain within the limits of the machine's movement amplitude (2 - DESCRIPTION).
- Do not load the platform if the machine needs to travel on a steep slope.

H - SHUTTING DOWN THE MACHINE

⚠ IMPORTANT ⚠

Machines with a diesel engine: before stopping the engine after intensive use, leave the engine idling for a few moments to allow the coolant and oil to gradually lower the temperature of the engine and prevent damage.

- INSTRUCTIONS: 2 - DESCRIPTION.
- Park the machine on a flat surface.
- Make sure that the machine is not stopped in any position that will interfere with the traffic flow and in particular the machine should not be less than one metre from a railway track.
- Never leave the ignition key in the machine during the operator's absence.
- Close and lock (if applicable) all the machine's covers.
- In the event of prolonged parking on a site, protect the machine from bad weather, particularly from frost. Machines with a diesel engine: check the antifreeze protection level.

INSTRUCTIONS FOR WELDING AND BLOW TORCH WORK ON AN EXTERNAL STRUCTURE

⚠ IMPORTANT ⚠

Ensure that there are no hydraulic or electrolyte leaks on the machine.

⚠ IMPORTANT ⚠

When welding, work in the opposite direction from the control panel to avoid sparks damaging it.

- Any welding and cutting (blowtorch) work from the platform on a building's metallic structures requires the following precautions to be taken:

A - WITH AN ELECTRICAL WELDING SET

- It is essential that the machine has a discharge braid connecting the chassis of the machine to the ground.
- It is also essential that the external structure to be welded is connected to the earth.
- If the above conditions are observed, the machine can, in this case, be in contact with the structure or the elements to be welded without damaging the electronic components.
- The power supply to the welding equipment must be via a grounded socket, including the extension lead if required.
- In all cases, make sure that there are no electric arcs in the platform or on the machine (contact between the rod or torch and ground plug of the welding equipment). For this, the ground plug of the welding equipment must never be placed on the machine's platform; it must only be placed as close as possible to the part to be welded.
- Switch off the welding equipment before disconnecting the ground clamp from the element or elements to be welded.

B - WITH A BLOW TORCH

- Attach the blow torch's bottles to the platform's vertical posts.
- Sparks and clippings must not be directed towards the battery or batteries.
- Do not set the blow torch down on the floor of the platform while it is still operating or point it towards the control panel or its power supply harness.

MACHINE MAINTENANCE INSTRUCTIONS

GENERAL INSTRUCTIONS

⚠ IMPORTANT ⚠

Carefully read and understand this instruction manual before working on this machine.

Carry out all repairs immediately, even if the repairs concerned are minor.

Repair all leaks immediately, even if the leak concerned is minor.

Be careful of the risk of burning and splashing (exhaust, radiator, engine, hydraulic oil, etc.).

- Wear clothes suitable for the maintenance of the machine, avoid wearing jewellery and loose clothes. Tie and protect your hair, if necessary.
- Ensure that process materials and of spare parts are disposed in all safely and in an ecological manner.
- Machines with a diesel engine:
 - Make sure the area is adequately ventilated before starting the engine.
 - Before working on the machine: turn off the engine and power down the machine (↩ 2 - DESCRIPTION).
- Electrical machines:
 - Before working on the machine: power down the machine (↩ 2 - DESCRIPTION).

MAINTENANCE

- Perform the periodic service (↩ 3 - MAINTENANCE) to keep your machine in good working condition. Failure to perform the periodic service may annul the contractual guarantee.

MAINTENANCE LOGBOOK

- The maintenance operations carried out in accordance with the recommendations given in section 3 - MAINTENANCE and the other inspection, servicing or repair operations or modifications performed on the machine must be recorded in a maintenance logbook.
- The entry for each operation shall include details of the date of the works, the names of the individuals or companies having performed them, the type of operation and its frequency, if applicable.
- The part numbers of any machine items replaced shall also be indicated.

LUBRICANT AND FUEL LEVELS

- Use the recommended lubricants and never use contaminated lubricants.
- Machines with a diesel engine:
 - Do not fill the fuel tank when the engine is running.
 - Only fill up the fuel tank in areas specified for this purpose.
 - Do not smoke or approach the machine with a flame, when the fuel tank is open or is being filled.

HYDRAULICS

⚠ IMPORTANT ⚠

COUNTERBALANCE VALVE: it is dangerous to change the setting or remove the counterbalance valves or safety valves which may be fitted to your machine's cylinders.

These operations must only be performed by approved personnel (consult your dealer).

HYDRAULIC ACCUMULATOR (depending on the model): it is dangerous to disassemble the hydraulic accumulators and their pipes that may be on your machine. These operations must only be performed by approved personnel (consult your dealer).

- Any work on the hydraulic circuit is forbidden except for the operations described in section 3 - MAINTENANCE.
- Do not attempt to loosen unions, hoses or hydraulic components with the circuit under pressure.

ELECTRICITY

⚠ IMPORTANT ⚠

*Certain maintenance operations may need electrical accreditation: comply with local, government and national regulations in force.
After each job, make sure that electrical component protection is put back in place (caps, covers, terminal covers, etc.).*

- Do not drop metallic items on the battery or batteries (between the positive and negative terminals).
- Disconnect the battery or batteries before working on the electrical circuit.
- The control panels on the ground and in the platform and all other electrical control boxes must only be opened by authorised personnel.

TILT SENSOR

⚠ IMPORTANT ⚠

Some machines are fitted with a tilt sensor attached to the turntable (↖ 2 - DESCRIPTION: CONTROL PANEL AND SAFETY DEVICES ON THE GROUND), always carry out an initialisation after removing/refitting the tilt sensor. Refer to the machine repair manual.

Some platforms are fitted with a tilt sensor that is integrated into the ground level control panel (↖ 2 - DESCRIPTION: CONTROL PANEL AND SAFETY DEVICES ON THE GROUND), always calibrate the tilt sensor after removing/refitting or loosening/tightening the ground level control panel, its mounting plates or fixing screws. Refer to the machine repair manual.

WELDING ON THE MACHINE

⚠ IMPORTANT ⚠

Welding operations on the machine for the purposes of maintenance or repairs must only be carried out by persons authorised by MANITOU.

- Disconnect the battery or batteries before doing any welding on the machine.
- When carrying out electric welding work on the machine, connect the negative cable from the welding equipment directly to the part being welded, so as to avoid high tension current passing through the alternator or the ring gear.
- If the machine is equipped with electronic controls, disconnect them before starting to weld, to avoid the risk of causing irreparable damage to electronic components.

WASHING THE MACHINE

⚠ IMPORTANT ⚠

When cleaning with a high pressure cleaner, avoid air from entering the engine, the piston rod wiper seals, the hinges, the structural components and the electrical connections, etc.

- Clean the machine or at least the area concerned before any intervention.
- Close and lock (if applicable) all the machine's covers.
- If necessary, protect components likely to be damaged, and in particular the electrical components (variable speed drive, charger) and electrical connections and the injection pump from penetration by water, steam or cleaning products.
- Clean the machine of any traces of fuel, oil or grease.
- After washing:
 - Dry the electrical components.
 - Grease the axles, pins, ring gear, etc.

IF THE MACHINE IS NOT TO BE USED FOR A LONG TIME

INTRODUCTION

⚠ IMPORTANT ⚠

*Procedures to follow if the machine is not to be used for a long time and for starting it up again afterwards must be performed by your dealership.
This period of long-term stoppage must not exceed 12 months.*

- The recommendations below are intended to prevent the machine from being damaged when it is withdrawn from service for a period longer than 6 months.

PREPARATION OF THE MACHINE

- Clean the machine thoroughly.
- Check and repair any leaks of fuel, oil, etc.
- Replace or repair any worn or damaged parts.
- Touch up the paintwork if necessary.
- Make sure the cylinder rods are in the retracted position (if applicable).
- Shut down the machine.
- Release the pressure in the hydraulic circuits.

MACHINES WITH A DIESEL ENGINE: ENGINE PROTECTION

- Fill the fuel tank (↩ 3 - MAINTENANCE).
- Replace the engine oil and oil filter (↩ 3 - MAINTENANCE).
- Replace the coolant (↩ 3 - MAINTENANCE).
- Disconnect the battery and store it in a safe place away from the cold, after charging it to a maximum.
- Block the outlet with waterproof adhesive tape.
- Remove the belt and store it in a safe place.
- Disconnect the engine cut-off solenoid on the injection pump and carefully insulate the connection.

ELECTRICAL MACHINES: BATTERY CHARGE

- In order to preserve battery life and capacity, check them periodically and keep the charge level constant (↩ 2 - DESCRIPTION).
- Do not leave the battery charger connected during a lightning storm.

PROTECTING THE MACHINE

- Protect cylinder rods that will not be retracted from corrosion.
- Wrap the wheels.

NOTE: if the machine is to be stored outdoors, cover it with a waterproof tarpaulin.

⚠ IMPORTANT ⚠

Make sure the area is adequately ventilated before starting machines with a diesel engine.

- Remove the protection from the cylinder rods and wheels.
- Check the hydraulic oil (↩ 3 - MAINTENANCE).
- Machines with a diesel engine:
 - Refit and reconnect the battery.
 - Remove the waterproof adhesive tape from the exhaust outlet.
 - Clean the fuel tank (replace the fuel), replace the fuel filter(s) (↩ 3 - MAINTENANCE).
 - Refit the belt and adjust its tension (↩ 3 - MAINTENANCE).
 - Reconnect the engine cut-off solenoid.
 - Start the engine, following the safety instructions and regulations.
- Perform the daily maintenance (↩ 3 - MAINTENANCE).
- Lubricate the machine completely (↩ 3 - MAINTENANCE).
- Carry out all the lifting system's hydraulic movements right up to the limit switches for each cylinder.

DISPOSING OF THE MACHINE



Consult your dealer before disposing of the machine.

RECYCLING OF MATERIALS

METALS

- Metals are 100% recoverable and recyclable.

PLASTICS

- Plastic parts are identified with a marking in accordance with current regulations.
- A limited range of materials is used to simplify the recycling process.
- The majority of the plastic components are made of "thermoplastic" plastics, which are easily recycled by melting, granulating or grinding.

RUBBER

- Tyres and seals can be ground for use in cement manufacture or to obtain reusable granules.

GLASS

- Glass items can be removed and collected for processing by glaziers.

ENVIRONMENTAL PROTECTION

By entrusting the maintenance of your machine to the MANITOU network, the risk of pollution is limited and the contribution to environmental protection is made.

WORN OR DAMAGED PARTS

- Do not dump them in the countryside.
- MANITOU and its network have signed-up to a scheme of environmental protection through recycling.

USED OIL

- The MANITOU network organises the collection and processing of used oil.
- By handing over your waste oil to MANITOU, the risk of pollution is limited.

USED BATTERIES

- Do not throw away batteries, as they contain metals that are harmful for the environment.
- Return them to the MANITOU network or any other approved collection point.

NOTE: MANITOU aims to manufacture machines that provide the best performance and limit polluting emissions.

2 - DESCRIPTION

2 - DESCRIPTION

<u>STICKERS</u>	2-4
<u>CHARACTERISTICS</u>	2-14
<u>DIMENSIONS AND DIAGRAM</u>	2-18
<u>SAFETY COMPONENTS</u>	2-20
<u>CONTROL PANEL AND SAFETY DEVICES AT GROUND LEVEL</u>	2-22
<u>CONTROL PANEL AND SAFETY DEVICES IN THE PLATFORM</u>	2-24
<u>GROUND LEVEL CONTROL PANEL SCREEN</u>	2-44
<u>OPERATING THE MACHINE</u>	2-52
<u>TRANSPORTING THE MACHINE</u>	2-58
<u>RESCUE PROCEDURE</u>	2-62
<u>OPTIONS</u>	2-66

STICKERS

⚠ IMPORTANT ⚠

*Clean all stickers so that they are legible.
Any stickers which are illegible or damaged must be replaced.
Check that the stickers are present after replacing any spare parts.*

1 - WHITE ARROW	Part No. 52816359 .	2-12
2 - BLACK ARROW	Part No. 52816430 .	2-12
3 - PLATFORM SAFETY INSTRUCTIONS	Part No. 52530068 .	2-12
4 - MAXIMUM LOAD CAPACITY IN THE PLATFORM	Part No. 52530106 .	2-12
5 - GROUND SAFETY INSTRUCTIONS	Part No. 685608 . . .	2-13
6 - WHEEL LOAD	Part No. 52531372 .	2-13
7 - DANGER OF CRUSHING HANDS	Part No. 676988 . . .	2-13
8 - DANGER - KEEP AWAY	Part No. 679450 . . .	2-13
9 - DANGER OF CRUSHING	Part No. 679452 . . .	2-14
10 - DANGER ROTATING PART	Part No. 683108 . . .	2-14
11 - DANGER HOT COMPONENT	Part No. 683112 . . .	2-14
12 - SAFETY STRUT	Part No. 678424 . . .	2-14
13 - WASHING INSTRUCTION	Part No. 313672 . . .	2-14
14 - HARNESS ATTACHMENT POINT	Part No. 834438 . . .	2-15
15 - EMERGENCY CONTROL PROCEDURE	Part No. 52531385 .	2-15
16 - FREEWHEEL AND WINCHING PROCEDURE	Part No. 52531387 .	2-15
17 - FREEWHEEL AND WINCHING PROCEDURE - HYDROSTATIC PUMP	Part No. 52538373 .	2-15
18 - ANCHORING POINT	Part No. 833041 . . .	2-15
19 - LIFTING POINT	Part No. 833291 . . .	2-16
20 - HYDRAULIC OIL	Part No. 597652 . . .	2-16
21 - DIESEL	Part No. 683437 . . .	2-16
22 - ANTIFREEZE (first version)	Part No. 597649 . . .	2-16
23 - ANTIFREEZE (second version)	Part No. 52501046 .	2-16
24 - BATTERY LOCATION	Part No. 52509705 .	2-17
25 - FAULT CODES	Part No. 52536099 .	2-17
26 - PLATFORM KEY LOCATION (depending on version)	Part No. 598897 . . .	2-17
27 - LIVE ELECTRICAL COMPONENTS	Part No. 52720522 .	2-17
28 - BATTERY CUT-OFF (OPTION)	Part No. 598894 . . .	2-17
29 - ELECTRICAL HAZARD (OPTION)	Part No. 678451 . . .	2-18
30 - POWER SUPPLY FOR 230 V SOCKET IN THE PLATFORM (OPTION)	Part No. 518548 . . .	2-18
31 - 230 V ELECTRICAL SYSTEM (OPTION)	Part No. 518548 . . .	2-18
32 - 110 V ELECTRICAL SYSTEM (OPTION)	Part No. 314681 . . .	2-18
33 - HYDRAULIC OIL HEATER (OPTION)	Part No. 52633500 .	2-18
34 - ENGINE BLOCK HEATER (OPTION)	Part No. 831342 . . .	2-19
35 - BATTERY HEATER (OPTION)	Part No. 52633504 .	2-19
36 - ELECTRICAL SAFETY DISTANCES	Part No. 834436 . . .	2-19
37 - USE MANITOU APPROVED TYRE ONLY	Part No. 834437 . . .	2-19
38 - DANGER OF BURNS	Part No. 683109 . . .	2-19

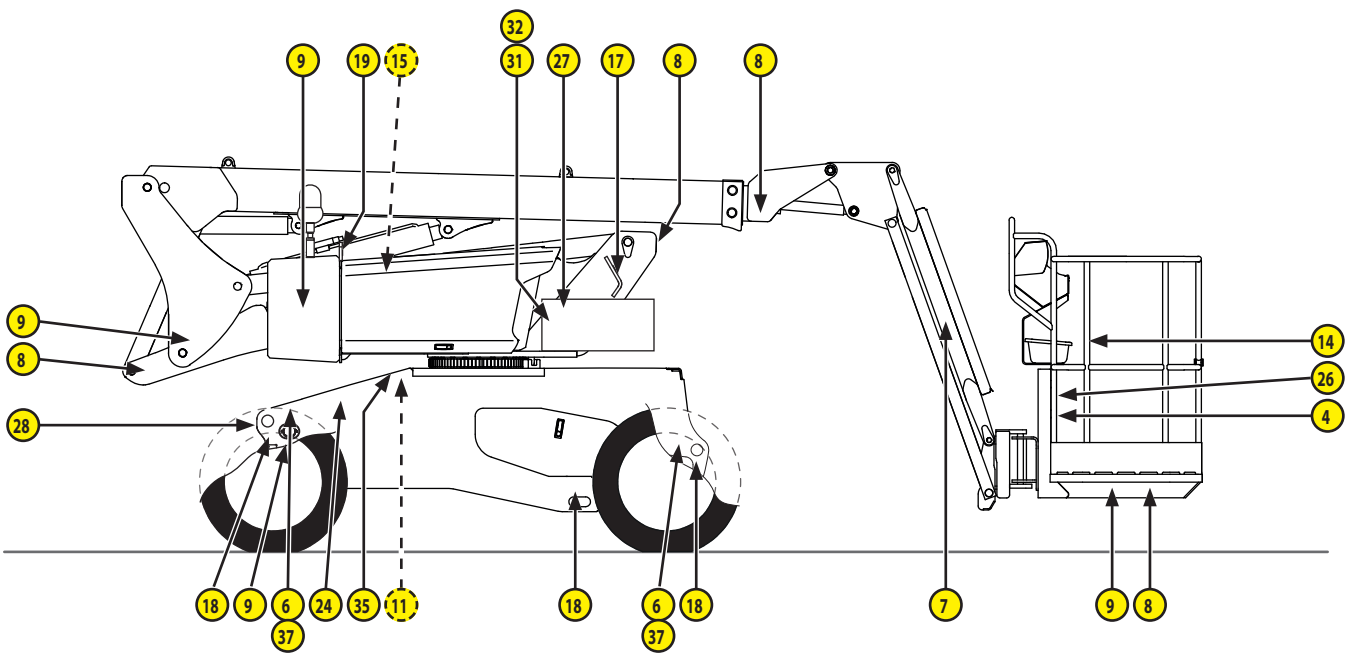
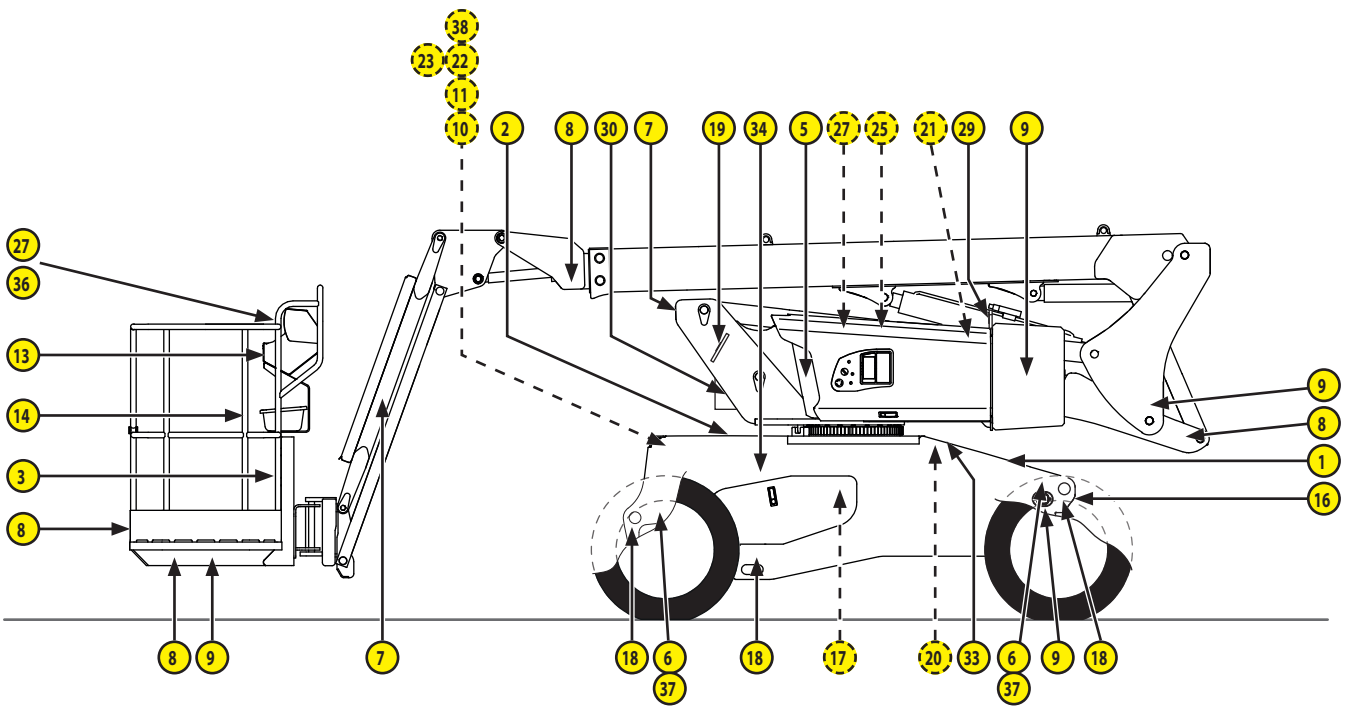

- → The sticker is located on the outside of the machine, it is directly visible.
- - - - → The sticker is located on the inside of the machine. The cover needs opening or removing to see it.

1 - WHITE ARROW

Part No. 52816359

Indicates the forward direction of travel when the turntable and the platform are in NEUTRAL POSITION,  OPERATING THE MACHINE: TRANSPORT/WORKING POSITION.

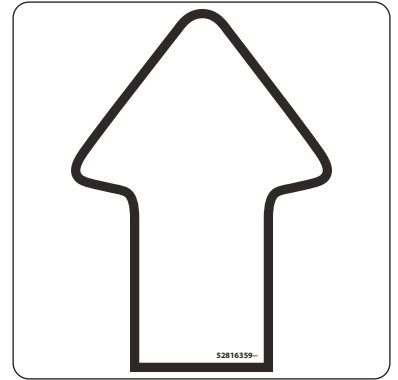

2 - BLACK ARROW

Part No. 52816430

Indicates the backward direction of travel when the turntable and the platform are in NEUTRAL position,  OPERATING THE MACHINE: TRANSPORT/WORKING POSITION.

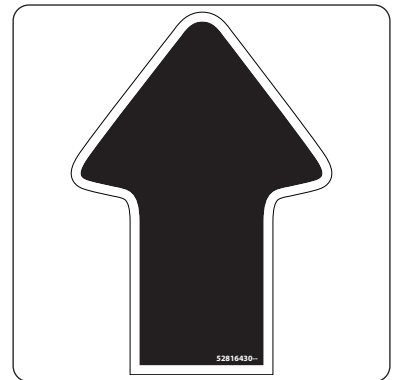

3 - PLATFORM SAFETY INSTRUCTIONS

Part No. 52530068

Indicates:

- ① Refer to this manual for the platform's maximum load capacity
- ② The safety and operating instructions must be read before starting the machine
- ③ Operating the machine outside and inside
- ④ The maximum wind speed when operating outside
- ⑤ The maximum manual force
- ⑥ The maximum tilt in WORKING position
- ⑦ The risk of electric shock

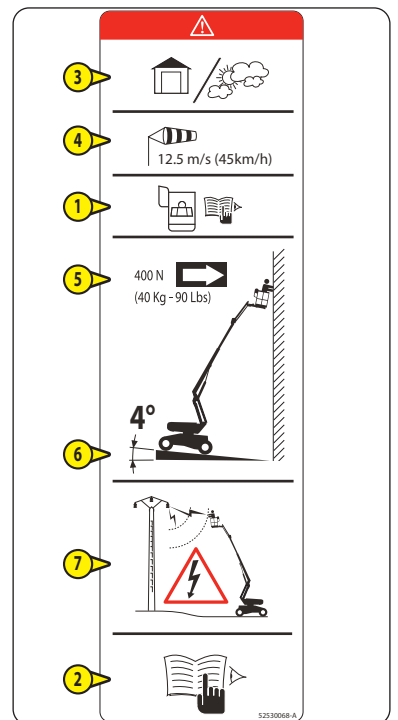

4 - MAXIMUM LOAD CAPACITY IN THE PLATFORM

Part No. 52530106

Indicates the maximum load capacity in the platform.

NOTE: each machine has its own specific capacity. Please refer to this sticker for your machine.

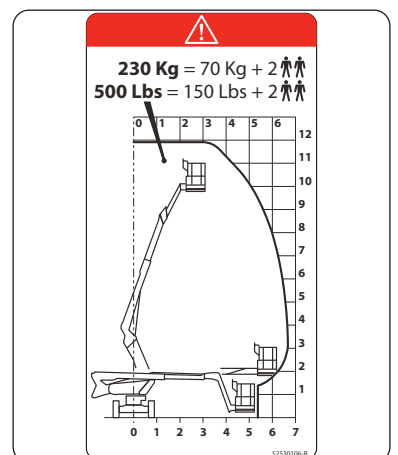

5 - GROUND SAFETY INSTRUCTIONS

Part No. 685608

Indicates:

- 1 The safety and operating instructions must be read before starting the machine
- 2 That the machine must not be towed in the event of breakdown
- 3 That it is strictly forbidden to direct a pressure washer nozzle over the control panels and electrical components

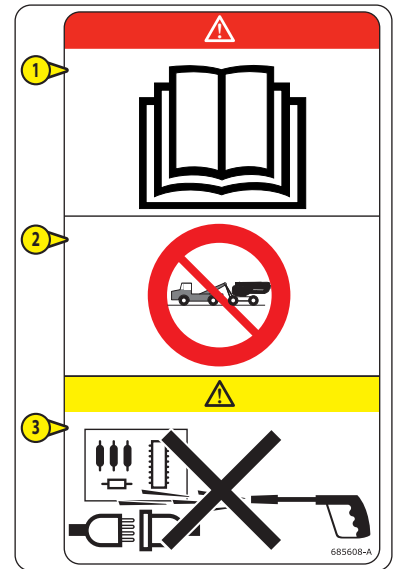

6 - WHEEL LOAD

Part No. 52531372

Indicates the maximum ground load per wheel.

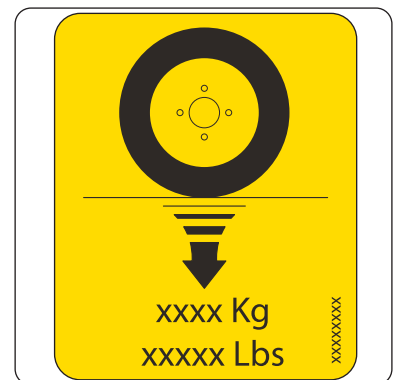

7 - DANGER OF CRUSHING HANDS

Part No. 676988

Indicates that it is strictly forbidden to place your hands or any other part of the body in the lifting mechanism components (arms, jib, platform, etc.).



8 - DANGER - KEEP AWAY

Part No. 679450

Indicates that it is strictly forbidden to stand under the lifting mechanism (arms, jib, platform, etc.) or within the machine's operating area.



9 - DANGER OF CRUSHING

Part No. 679452

Indicates that it is strictly prohibited to stand in this area when the machine is moving: the components to which the stickers are affixed could crush you.



10 - DANGER ROTATING PART

Part No. 683108

Indicates that there is a high risk of severing fingers with the radiator fan.



11 - DANGER HOT COMPONENT

Part No. 683112

Indicates that there is a high risk of burns in the vicinity (diesel engine muffler, diesel engine, etc.).



12 - SAFETY STRUT

Part No. 678424

Indicates that the safety strut must be used when working under the secondary arm in the raised position, ≤ 3 - MAINTENANCE: OCCASIONAL OPERATIONS.

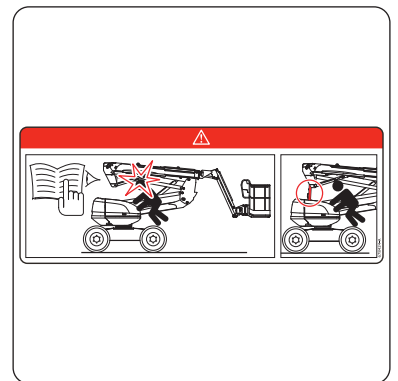

13 - WASHING INSTRUCTION

Part No. 313672

Indicates that it is strictly forbidden to direct a high pressure cleaner nozzle over the control panels and electrical components or on the diesel engine air intake.

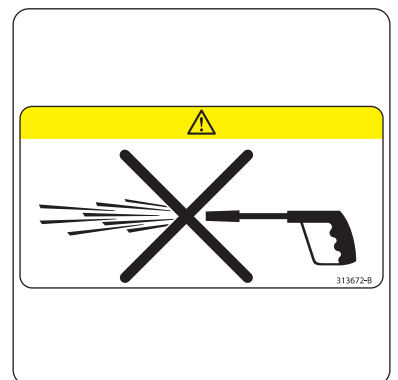

14 - HARNESS ATTACHMENT POINT

Part No. 834438

Indicates the location of the safety harness attachment points, SAFETY COMPONENTS: HARNESS ATTACHMENT POINTS.



15 - EMERGENCY CONTROL PROCEDURE

Part No. 52531385

Indicates the procedure to be followed for using the emergency controls, RESCUE PROCEDURE.



16 - FREEWHEEL AND WINCHING PROCEDURE

Part No. 52531387

Indicates the procedure to follow to set the machine in freewheel and winch it, 3 - MAINTENANCE: OCCASIONAL OPERATIONS: WINCHING THE MACHINE.

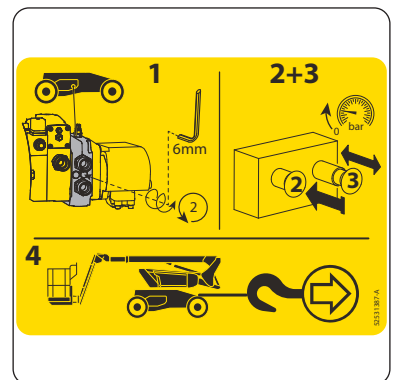

17 - FREEWHEEL AND WINCHING PROCEDURE - HYDROSTATIC PUMP

Part No. 52538373

Indicates the procedure to be followed for bypassing the hydrostatic circuit, 3 - MAINTENANCE: OCCASIONAL OPERATIONS: WINCHING THE MACHINE.

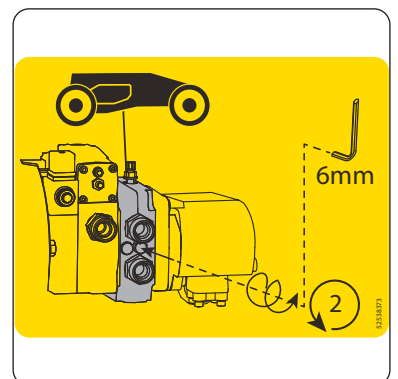

18 - ANCHORING POINT

Part No. 833041

Indicates the location of the machine's anchoring points, OPERATING THE MACHINE: TRANSPORTING THE MACHINE.

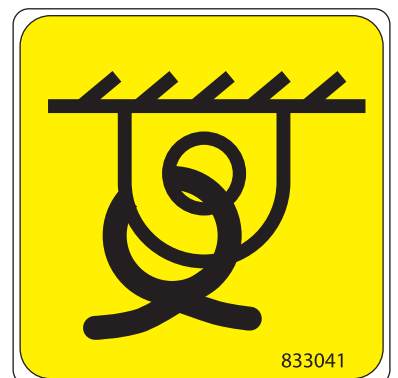

19 - LIFTING POINT

Part No. 833291

Indicates the location of the machine's lifting points,  3 - MAINTENANCE: OCCASIONAL OPERATION.

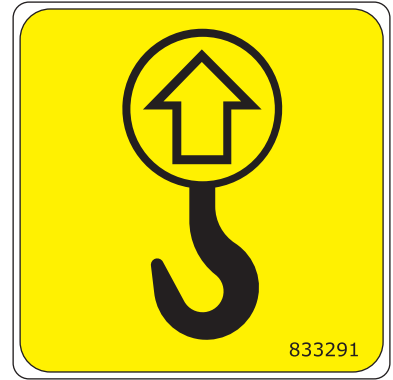

20 - HYDRAULIC OIL

Part No. 597652

This indicates that the tank is intended to contain only hydraulic oil.

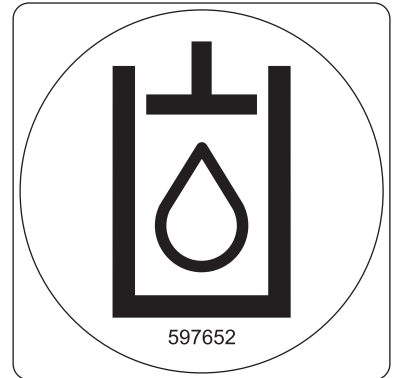

21 - DIESEL

Part No. 683437

Indicates that the tank is intended to contain only diesel fuel.



22 - ANTIFREEZE (first version)

Part No. 597649

23 - ANTIFREEZE (second version)

Part No. 52501046

This indicates that there is antifreeze in the diesel engine.

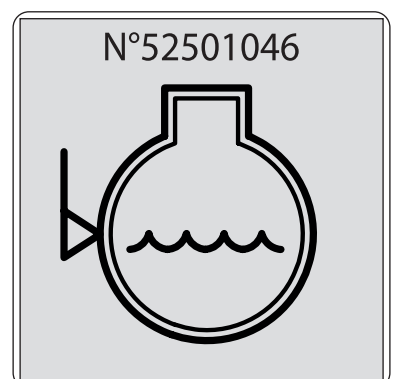
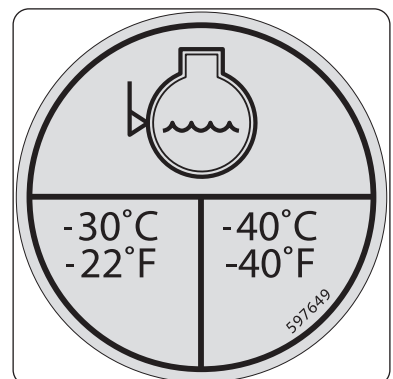

24 - BATTERY LOCATION

Part No. 52509705

Indicates location of battery.

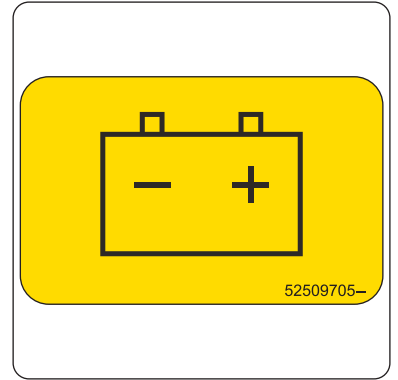

25 - FAULT CODES

Part No. 52536099

Indicates the fault codes and location of the electrical components:

- Sensors (AS, DS, IS, TS)
- Electrovalves (EV)
- Solenoid coils (EW)

CODES DEFAULTS		DEFAULT CODE
DS301	TS100	A- Short circuit at starting
DS302	IS200	B- Out neutral
EW100	IS207	C- Open circuit
EW101		D- Short circuit (E+)
EW102		E- High level default
EW103		F- Out surge valve
EW104		G- High level default
EW105		H- Low level default
EW106		I- Memory default
EW107		J- Communication default
EW108		K- Battery default
EW109		L- Functional warning
EW110		M- Actuating default
EW111		
EW112		
EW113		
EW114		
EW115		
EW116		
EW117		
EW118		
EW119		
EW120		
EW121		
EW122		
EW123		
EW124		
EW125		
EW126		
EW127		
EW128		
EW129		
EW130		
EW131		
EW132		
EW133		
EW134		
EW135		
EW136		
EW137		
EW138		
EW139		
EW140		
EW141		
EW142		
EW143		
EW144		
EW145		
EW146		
EW147		
EW148		
EW149		
EW150		
EW151		
EW152		
EW153		
EW154		
EW155		
EW156		
EW157		
EW158		
EW159		
EW160		
EW161		
EW162		
EW163		
EW164		
EW165		
EW166		
EW167		
EW168		
EW169		
EW170		
EW171		
EW172		
EW173		
EW174		
EW175		
EW176		
EW177		
EW178		
EW179		
EW180		
EW181		
EW182		
EW183		
EW184		
EW185		
EW186		
EW187		
EW188		
EW189		
EW190		
EW191		
EW192		
EW193		
EW194		
EW195		
EW196		
EW197		
EW198		
EW199		
EW200		
EW201		
EW202		
EW203		
EW204		
EW205		
EW206		
EW207		
EW208		
EW209		
EW210		
EW211		
EW212		
EW213		
EW214		
EW215		
EW216		
EW217		
EW218		
EW219		
EW220		
EW221		
EW222		
EW223		
EW224		
EW225		
EW226		
EW227		
EW228		
EW229		
EW230		
EW231		
EW232		
EW233		
EW234		
EW235		
EW236		
EW237		
EW238		
EW239		
EW240		
EW241		
EW242		
EW243		
EW244		
EW245		
EW246		
EW247		
EW248		
EW249		
EW250		
EW251		
EW252		
EW253		
EW254		
EW255		
EW256		
EW257		
EW258		
EW259		
EW260		
EW261		
EW262		
EW263		
EW264		
EW265		
EW266		
EW267		
EW268		
EW269		
EW270		
EW271		
EW272		
EW273		
EW274		
EW275		
EW276		
EW277		
EW278		
EW279		
EW280		
EW281		
EW282		
EW283		
EW284		
EW285		
EW286		
EW287		
EW288		
EW289		
EW290		
EW291		
EW292		
EW293		
EW294		
EW295		
EW296		
EW297		
EW298		
EW299		
EW300		
EW301		
EW302		
EW303		
EW304		
EW305		
EW306		
EW307		
EW308		
EW309		
EW310		
EW311		
EW312		
EW313		
EW314		
EW315		
EW316		
EW317		
EW318		
EW319		
EW320		
EW321		
EW322		
EW323		
EW324		
EW325		
EW326		
EW327		
EW328		
EW329		
EW330		
EW331		
EW332		
EW333		
EW334		
EW335		
EW336		
EW337		
EW338		
EW339		
EW340		
EW341		
EW342		
EW343		
EW344		
EW345		
EW346		
EW347		
EW348		
EW349		
EW350		
EW351		
EW352		
EW353		
EW354		
EW355		
EW356		
EW357		
EW358		
EW359		
EW360		
EW361		
EW362		
EW363		
EW364		
EW365		
EW366		
EW367		
EW368		
EW369		
EW370		
EW371		
EW372		
EW373		
EW374		
EW375		
EW376		
EW377		
EW378		
EW379		
EW380		
EW381		
EW382		
EW383		
EW384		
EW385		
EW386		
EW387		
EW388		
EW389		
EW390		
EW391		
EW392		
EW393		
EW394		
EW395		
EW396		
EW397		
EW398		
EW399		
EW400		
EW401		
EW402		
EW403		
EW404		
EW405		
EW406		
EW407		
EW408		
EW409		
EW410		
EW411		
EW412		
EW413		
EW414		
EW415		
EW416		
EW417		
EW418		
EW419		
EW420		
EW421		
EW422		
EW423		
EW424		
EW425		
EW426		
EW427		
EW428		
EW429		
EW430		
EW431		
EW432		
EW433		
EW434		
EW435		
EW436		
EW437		
EW438		
EW439		
EW440		
EW441		
EW442		
EW443		
EW444		
EW445		
EW446		
EW447		
EW448		
EW449		
EW450		
EW451		
EW452		
EW453		
EW454		
EW455		
EW456		
EW457		
EW458		
EW459		
EW460		
EW461		
EW462		
EW463		
EW464		
EW465		
EW466		
EW467		
EW468		
EW469		
EW470		
EW471		
EW472		
EW473		
EW474		
EW475		
EW476		
EW477		
EW478		
EW479		
EW480		
EW481		
EW482		
EW483		
EW484		
EW485		
EW486		
EW487		
EW488		
EW489		
EW490		
EW491		
EW492		
EW493		
EW494		
EW495		
EW496		
EW497		
EW498		
EW499		
EW500		
EW501		
EW502		
EW503		
EW504		
EW505		
EW506		
EW507		
EW508		
EW509		
EW510		
EW511		
EW512		
EW513		
EW514		
EW515		
EW516		
EW517		
EW518		
EW519		
EW520		
EW521		
EW522		
EW523		
EW524		
EW525		
EW526		
EW527		
EW528		
EW529		
EW530		
EW531		
EW532		
EW533		
EW534		
EW535	</	

29 - ELECTRICAL HAZARD (OPTION)

Part No. 678451

Indicates an electrical hazard.

Note:

- For 110 V 3.5 kW electric generator option.
- For 230 V 3.5 kW electric generator option.

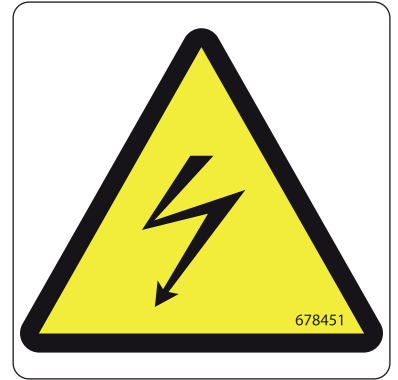

30 - POWER SUPPLY FOR 230 V SOCKET IN THE PLATFORM (OPTION) Part No. 518548

Indicates:

- 1 The voltage and the amperage of the power source.
- 2 That the electrical system is protected by a 30 mA residual-current circuit breaker.
- 3 The cross-section of the cables in the electrical system.

Note: for 230 V electric power socket option in the platform (quantity = 1).

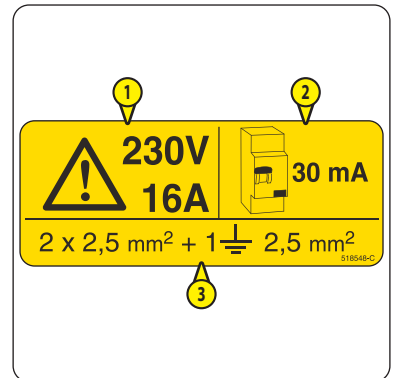

31 - 230 V ELECTRICAL SYSTEM (OPTION)

Part No. 518548

Indicates:

- 1 The voltage and the amperage of the electrical system.
- 2 That the electrical system is protected by a 30 mA residual-current circuit breaker.
- 3 The cross-section of the cables in the electrical system.
 - Note: for 230 V 3.5 kW electric generator option (quantity = 1).

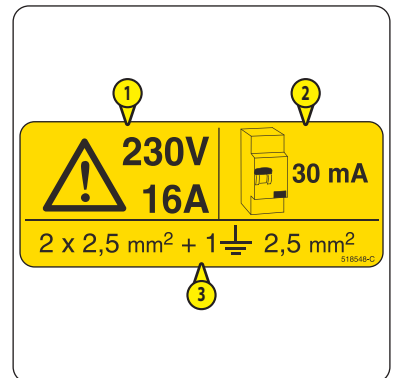

32 - 110 V ELECTRICAL SYSTEM (OPTION)

Part No. 314681

Indicates:

- 1 The voltage and the amperage of the electrical system.
- 2 That the electrical system is protected by a 30 mA residual-current circuit breaker.
- 3 The cross-section of the cables in the electrical system.

Note: for 110 V 3.5 kW electric generator option.

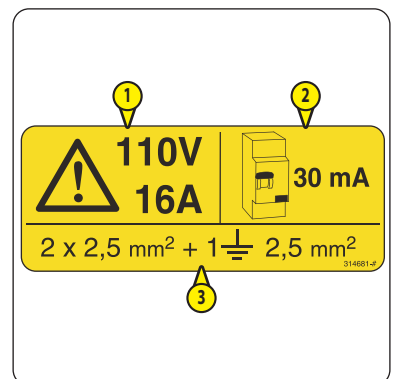

33 - HYDRAULIC OIL HEATER (OPTION)

Part No. 52633500

Indicates:

- The location of the hydraulic oil heater plug.
- 1 That the diesel engine must be stopped and that the instruction manual should be consulted before connecting the hydraulic oil heater.
 - 2 The voltage of the power source.

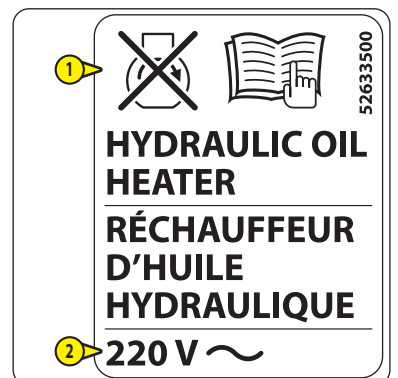

34 - ENGINE BLOCK HEATER (OPTION)

Part No. 831342

Indicates:

- The location of the engine block heater plug.
- ① The voltage and the amperage of the power source and that the electrical system is protected by a 30 mA residual-current circuit breaker.
- ② That the diesel engine must be stopped before connecting the engine block heater.



35 - BATTERY HEATER (OPTION)

Part No. 52633504

Indicates:

- The location of the battery heater plug.
- ① That the diesel engine must be stopped and that the instruction manual should be consulted before connecting the battery heater.
- ② The voltage of the power source.

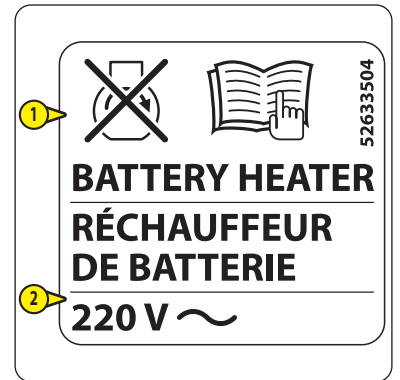

36 - ELECTRICAL SAFETY DISTANCES

Part No. 834436

Indicates the different areas in which the platform can be operated close to electrical power lines.

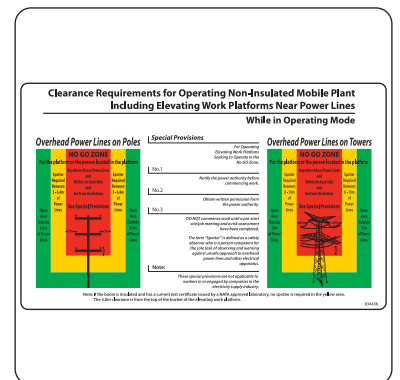

37 - USE MANITOU APPROVED TYRE ONLY

Part No. 834437

Indicates that the operator is using the tyres specified by Manitou.



38 - DANGER OF BURNS

Part No. 683109

Indicates that there is a significant risk of a spray of steam or boiling-hot liquid being released when turning the radiator filler cap.



CHARACTERISTICS

LOAD SPECIFICATIONS			±
Machine			
- Maximum platform capacity	kg (lbs)	230 (507)	-
- Maximum wind speed when operating outside	km/h	45 (28)	-
- Maximum number of people in the platform (indoor use/ outdoor use)		2/2	-
- Machine weight, unladen	kg (lbs)	4150 (9150)	2%
- Authorized maximum tilt	°	4	0%
- Maximum slope accessible (+100 kg)	%	45	1%
- Maximum authorized lateral manual force	N	400	-
Wheels			
- Load on one front wheel (TRANSPORT position)	kg (lbs)	1142 (2.517)	2%
- Load on one rear wheel (TRANSPORT position)	kg (lbs)	933 (2.057)	2%
- Maximum load on one wheel (WORKING position)	kg (lbs)	2685 (5.920)	2%
- Bearing surface on ground (hard/soft)	cm ² (in ²)	180.1 / 417.1 (27.9 / 64.6)	5%
- Punching on ground (hard/soft)	daN/cm ² (psi)	15 - 6.5 (217.6 / 87)	5%
SPEEDS AND MOVEMENTS			±
Driving speed			
- WORKING POSITION speed	km/h (mph)	1 (0.6)	0.1 (0.06)
- SLOW speed	km/h (mph)	not applicable	-
- TORTOISE speed	km/h (mph)	3.2 (2)	0.5 (0.31)
- RAMP speed	km/h (mph)	3.8 (2.4)	0.2 (0.12)
- HARE speed	km/h (mph)	5.2 (3.2)	0.2 (0.12)
Main/secondary arm (telescope extended)			
- Unladen/laden lifting	s	22 / 22	2
- Unladen/laden lowering	s	22 / 22	2
Main/secondary arm (telescope retracted)			
- Unladen/laden lifting	s	19 / 19	2
- Unladen/laden lowering	s	19 / 19	2
Telescope			
- Unladen/laden extension	s	9 / 9	2
- Unladen/laden retraction	s	9 / 9	2
Jib			
- Unladen/laden lifting	s	22 / 22	2
- Unladen/laden lowering	s	24 / 24	2
Turntable (350°)			
- Boom extended	s	80	5
- Telescope retracted	s	60	5
Platform			
- Left/right rotation	s	10 / 10	5

DIESEL ENGINE			±
Type		KUBOTA D1105-E4B	-
Fuel		Diesel	-
Number of cylinders		3	-
Displacement	cm ³ (cu.in)	1123 (68.5)	-
Idling speed unladen	rpm	1300 (1.300)	20
Maximum speed unladen	rpm	3000 (3.000)	40
Nominal power	kW (hp)	18.5 (24.8)	-
Maximum torque	Nm (lb.ft)	71 (52.4)	-
Type of cooling		water	-
Fan		suction	-
Emissions			
- CO (carbon monoxide)	g/kWh	1.4	-
- HC + Nox (hydrocarbons + nitrogen dioxide)	g/kWh	5.8	-
- PM (particles)	g/kWh	0.21	-
- CO ₂	g/kWh	-	-
TRANSMISSION			±
Main hydraulic pump			
- Type		POCLAIN HP closed circuit	-
- Displacement	cm ³ (cu.in)	20.4 (1.2)	-
- Maximum unladen flow rate	L/min (gpm)	61.2 (16.2)	-
- Maximum pressure	bar (psi)	350 (5,076.3)	-
Wheel motors			
- Type		POCLAIN MSE2	-
- Displacement	cm ³ (cu.in)	398 (24.3)	-
- Maximum pressure	bar (psi)	400 (5,801.5)	-
- Theoretical drawbar pull	daN (lbf)	1950 (4,383.8)	-
- Reduction ratio		1:1	-
- Tractive force	daN	1950	-
- Front axle differential		Hydraulic divider	-
- Rear axle differential		Hydraulic divider	-
Number of front/rear steering/directional wheels		2/0	-
Number of front/rear drive wheels		2/2	-
Wheels			
- Type		SOLIDEAL CURED ON	-
- Dimensions (external Ø x width)	mm (ft-in)	720 x 240 (2-4.3)	-
- Inflation		solid tire	-
BRAKE SYSTEM (parking brake)			±
Type of brake		Multi-disc	-
Type of control		Hydraulic negative	-
Front/rear braked wheels		2/2	-
Release (freewheel mode)		manual pump	-
Braking torque	daN.m	187.5	5%

HYDRAULIC CIRCUIT			±
Auxiliary hydraulic pump			
- Type		BOSCH REXROTH	-
- Displacement	cm ³ (cu.in)	14 (0.85)	-
- Maximum unladen flow rate	L/min (gpm)	42 (11.1)	-
Control valve			
- Type		HYDAC	
- Maximum pressure	bar (psi)	210 (3047)	5 (72)
ELECTRIC CIRCUIT			±
Battery			
- Type		EXIDE	-
- Capacity C5	Ah	-	-
- Capacity C20	Ah	110	-
- Rated voltage	V	12	-
Alternator			
- Type		Electric	-
- Maximum amperage	A	40	-
- Rated voltage	V	12	-
Starter			
- Type		Electric	-
- Power	kW (hp)	1.4 (1.2)	-
- Voltage	V	12	-
BACKUP PUMP			±
- Type		Manual	
- Displacement	cm ³ (cu.in)	20 (1.2)	-
DIMENSIONS			±
Working height = maximum height of the platform floor (H2) + 2,000 mm	mm (ft-in)	11900 (39-0.9)	1%
Working reach = max. reach (D1) + 500 mm	mm (ft-in)	6690 (21-11.4)	1%
Platform			
- External dimensions (length x width)	mm (ft-in)	1500 x 987 (4-11 x 3-2.9)	1%
- Floor dimensions (length x width)	mm (ft-in)	1435 x 710 (4-8.5 x 2-4)	1%
- Rotation angle right/left	°	70 / 66	1%
Jib displacement angle up/down	°	64 / 70	1%
Turntable rotation angle	°	350	-
Other dimensions: DIMENSIONS AND DIAGRAM.			

NOISE AND VIBRATION			±
Sound power level LwA	dB	100	-
Vibrations affecting body in the platform			
- Average quadratic values for the body	m/s ²	0.76	-
EQUIPMENT			±
Orange rotating beacon light		Standard	-
Hour meter		Standard	-
Proportional fuel level display		Standard	-
Low fuel level alarm		Standard	-
Low battery alarm		Standard	-
Toolbox in platform		Standard	-
User interface (diagnostic aid)		Standard	-
Oscillating front axle		Not applicable	-
Turntable orientation more than 90° indicator light		Not applicable	-
Remote control unit		Not applicable	-
Permanent orange rotating beacon light		Option*	-
All movements alarm		Option*	-
Driving/steering alarm		Option*	-
Battery cut-off		Option**	-
230 V socket in the platform		Option	-
Generator 110 V/3.5 kW (UK electric power socket)		Option**	-
Generator 220 V/3.5 kW		Option**	-
Hydraulic oil heater		Option	-
Water heater		Option	-
Battery heater		Option	-
Damper valve		Option	-
Compressed air provision in the platform		Option	-
Compressed water provision in the platform		Option	-
Key lock for turntable covers		Option**	-
Worklight		Option**	-
Non-marking tires		Option	-
Secondary protection system SPS - first version "SafeManSystem"		Option**	-
Secondary protection system SPS - second version		Option**	-
Platform with gate		Not applicable	-

*: DEFINITION OF SUB-MENUS.

**&: OPTIONS.

DIMENSIONS AND DIAGRAM

A	mm	5500
A1	mm	4500
B	mm	2000
B1	mm	950
C	mm	2015
C1	mm	2495
D	mm	1800
E	mm	200
E1	mm	320
F	mm	395
G	mm	1715
G1	mm	4115
H	mm	920
I	mm	190
J	mm	2900
K	° / %	36 / 73

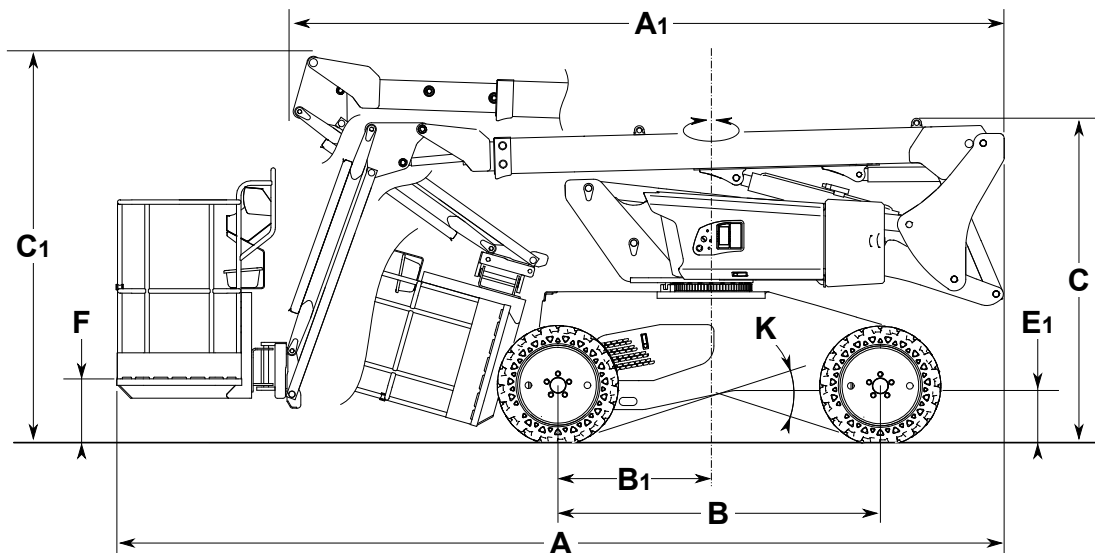
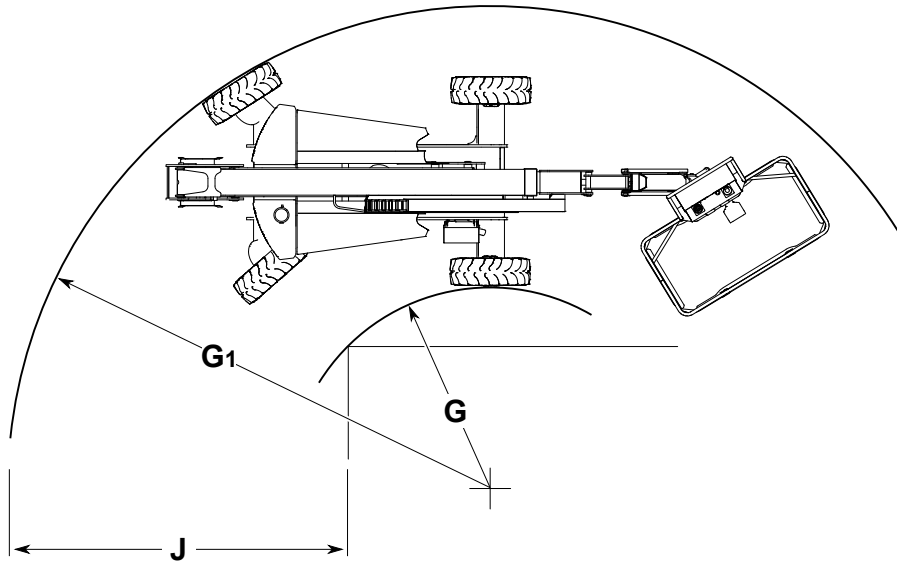
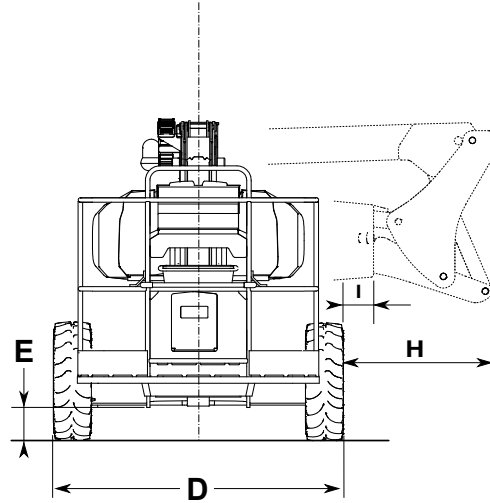

H1	mm	1940
D1	mm	6190
H2	mm	9900
D2	mm	3100
S5	mm	5000
H5	mm	6620
D5	mm	5410
S7	mm	7310
H7	mm	8565
D7	mm	3950

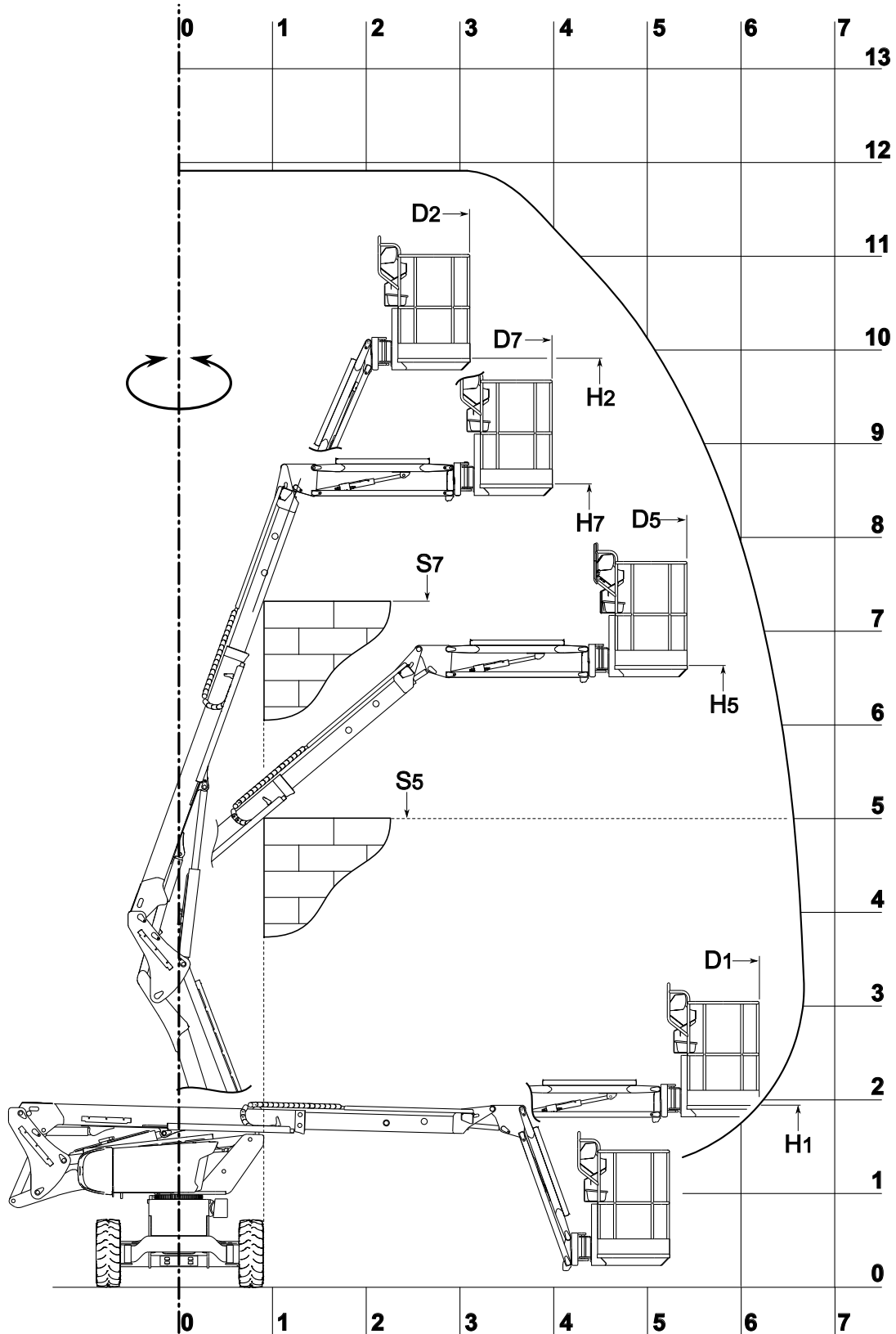

SAFETY COMPONENTS

SLIDING MID RAIL

⚠ IMPORTANT ⚠

*Do not attach the sliding mid rail in the high position.
Make sure that the sliding mid rails are in the low position before using the machine.*

The platform has 1 sliding mid rail ①.

- Lift up the sliding mid rail to get into and out of the platform.

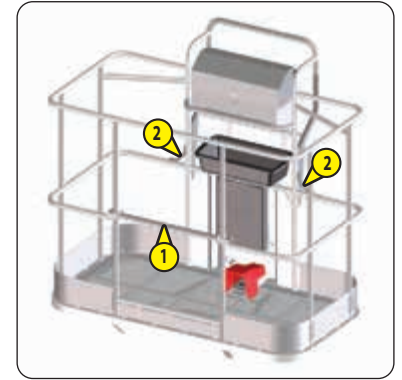

HARNESS ATTACHMENT POINTS

⚠ IMPORTANT ⚠

Only one operator is permitted to use each attachment point.

- Attach the safety harnesses to the attachment points ② in the platform
- NB: 2 attachment points, ⚠ STICKERS: HARNESS ATTACHMENT POINTS.

TURNTABLE LOCKING PIN

Locking the turntable prevents it from rotating.

Position ①A: the turntable is unlocked.

Position ①B: the turntable is locked.

LOCK THE TURNTABLE

- Align the pin ① and the chassis ①A notch
- Pull the pin and turn it to the right
- Push it into the chassis notch (position ①B)

UNLOCK THE TURNTABLE

- Pull the pin ① and turn it to the left
- Push it into position ①A

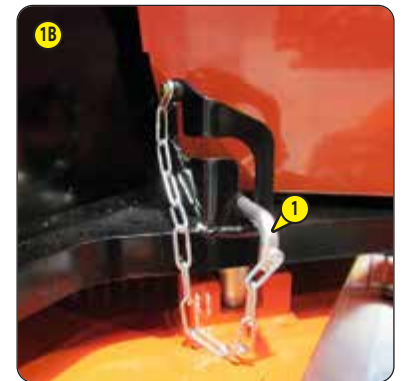
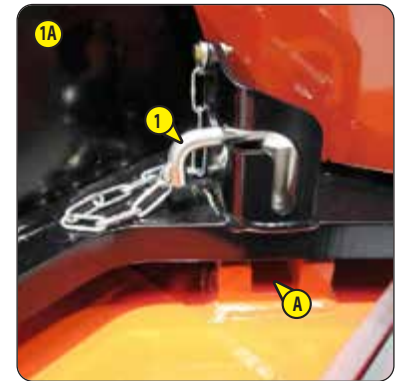

CONTROL PANEL AND SAFETY DEVICES AT GROUND LEVEL

⚠ IMPORTANT ⚠

Left and right are defined in OPERATING THE MACHINE: TRANSPORT/WORKING POSITION.

From machine MAN00000K01079391, the tilt sensor is integrated into the ground level control panel (← 1 - OPERATING AND SAFETY INSTRUCTIONS: MACHINE MAINTENANCE INSTRUCTIONS).

#1 FIRST VERSION

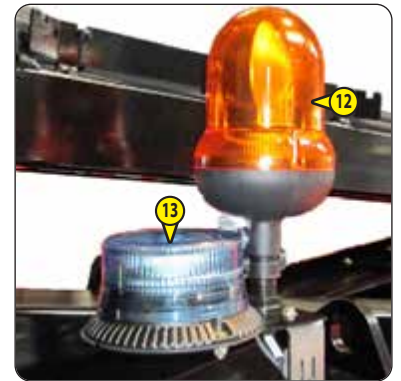
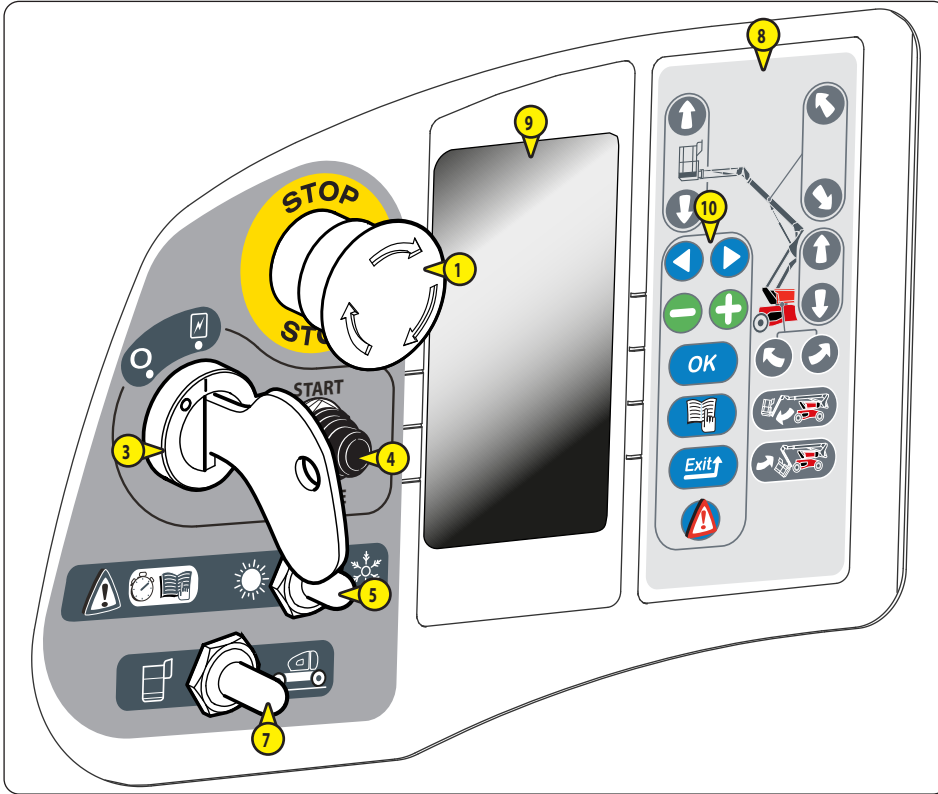

#2 SECOND VERSION

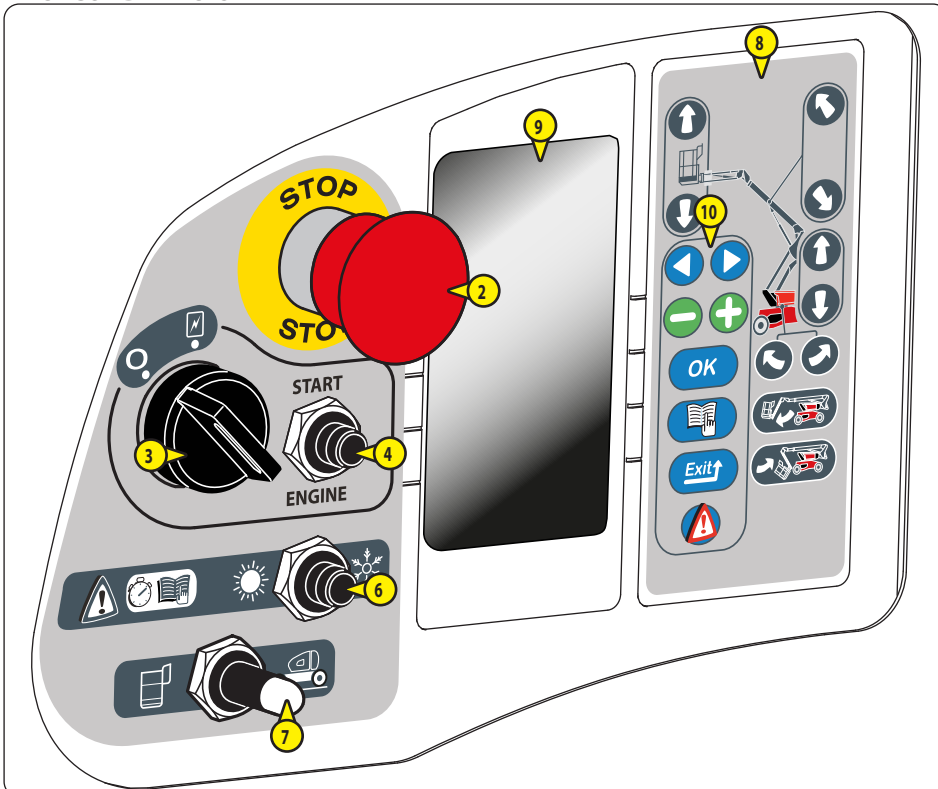

#3 THIRD VERSION

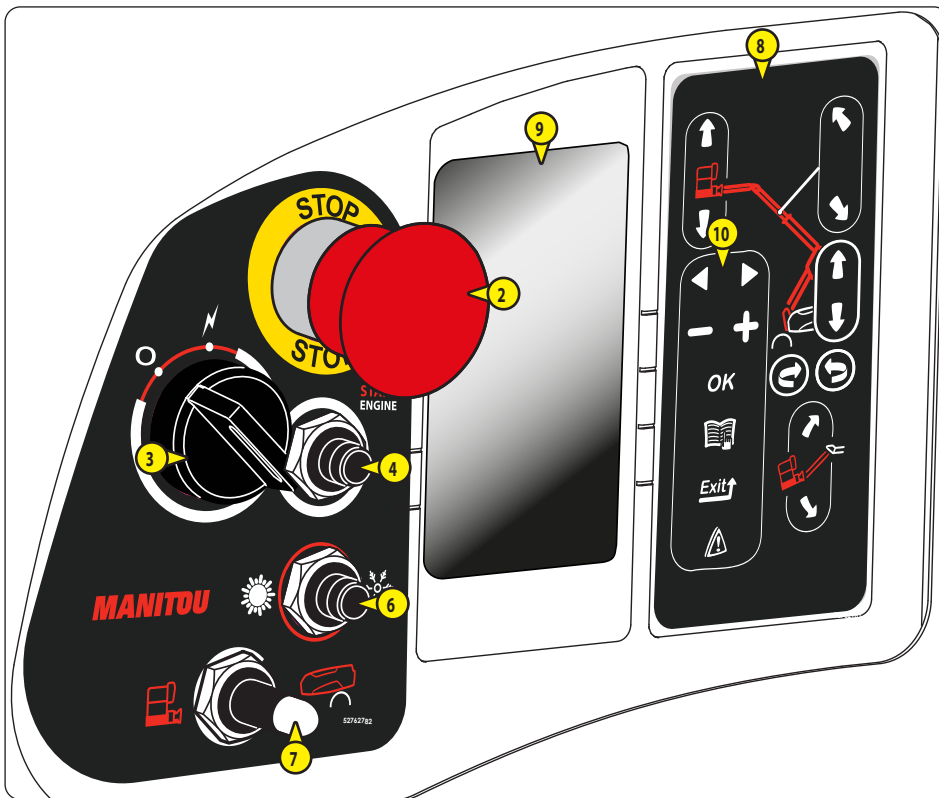

1 - EMERGENCY STOP BUTTON (first version)	2-26
2 - EMERGENCY STOP BUTTON (second and third versions)	2-26
3 - IGNITION SWITCH	2-26
4 - DIESEL ENGINE STARTER BUTTON	2-27
5 - DIESEL ENGINE START MODE SWITCH (first version)	2-27
6 - DIESEL ENGINE START MODE BUTTON (second and third versions)	2-27
7 - GROUND LEVEL/PLATFORM CONTROLS SELECTOR SWITCH	2-28
8 - MACHINE MOVEMENT CONTROL KEYS	2-29
9 - SCREEN	2-29
10 - CONTROL KEYS	2-29
11 - HORN	2-30
12 - ORANGE ROTATING BEACON LIGHT	2-30
13 - FLASHING LIGHT SPS (OPTION)	2-30
14 - TILT SENSOR up to machine MAN 00000P01079390	2-30

CONTROL PANEL AND SAFETY DEVICES IN THE PLATFORM

⚠ IMPORTANT ⚠

Front, rear, left and right are defined in **OPERATING THE MACHINE: TRANSPORT/WORKING POSITION.**

#1 FIRST VERSION

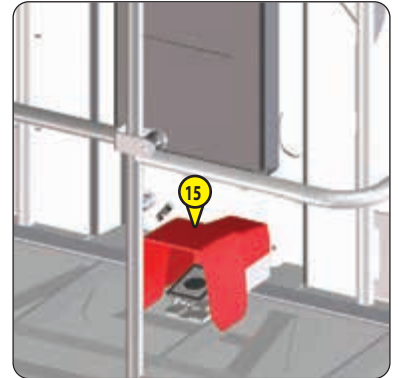
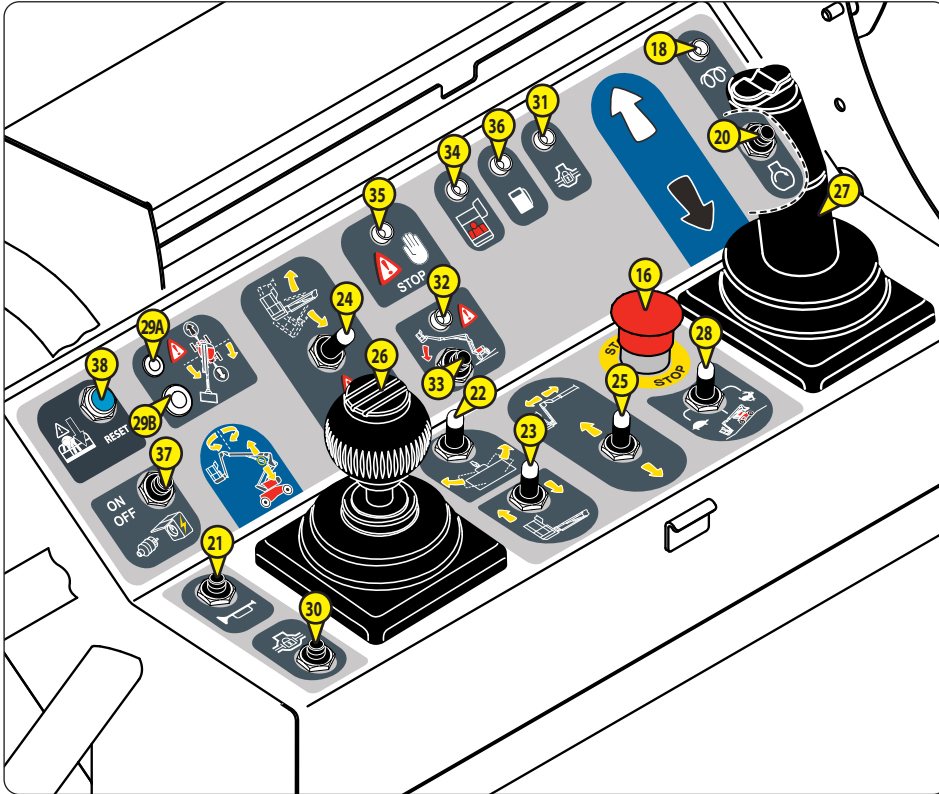

#2 SECOND VERSION

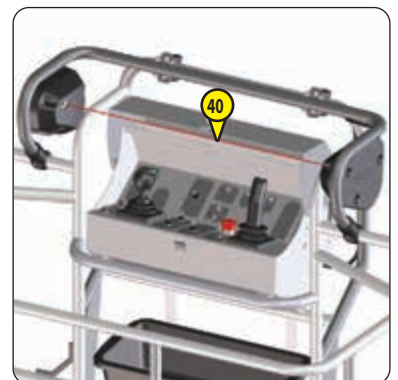
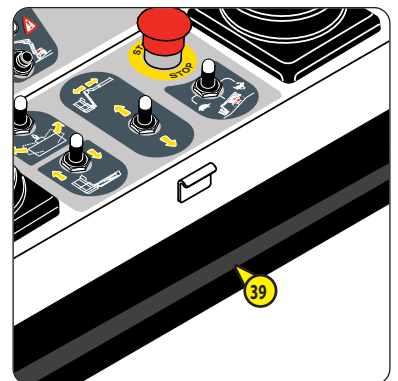
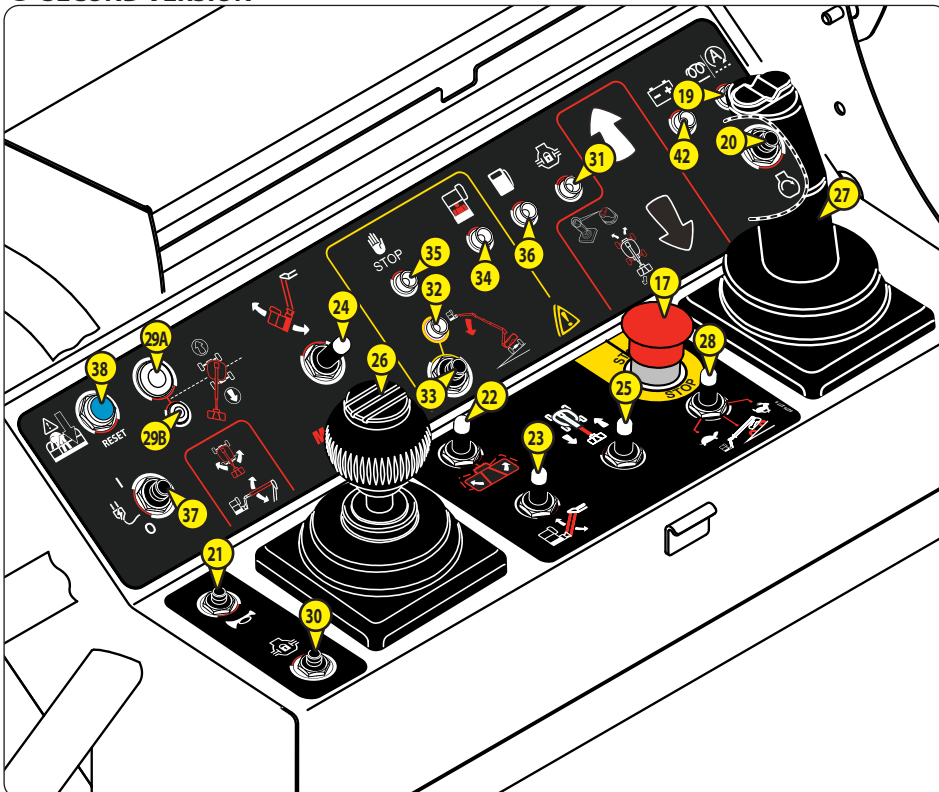

15 - PEDAL SWITCH	2-31
16 - EMERGENCY STOP BUTTON (first version)	2-31
17 - EMERGENCY STOP BUTTON (second version)	2-31
18 - PREHEAT LIGHT (first version)	2-32
19 - PREHEAT LIGHT (second version)	2-32
20 - DIESEL ENGINE STARTER BUTTON	2-32
21 - HORN BUTTON	2-33
22 - PLATFORM ROTATION SWITCH	2-33
23 - JIB SWITCH	2-34
24 - PLATFORM/JIB TILT SWITCH	2-34
25 - TELESCOPE SWITCH	2-35
26 - MAIN/SECONDARY ARM AND TURNTABLE CONTROL HANDLE	2-35
27 - DRIVING/STEERING CONTROL HANDLE	2-36
28 - DRIVING SPEED SELECTION SWITCH	2-37
29 - NOT USED	2-37
30 - DIFFERENTIAL LOCKING BUTTON	2-38
31 - DIFFERENTIAL LOCK WARNING LIGHT	2-38
32 - TILT WARNING INDICATOR LAMP	2-39
33 - USE ON SLOPE BUTTON	2-39
34 - OVERLOAD WARNING INDICATOR LAMP	2-39
35 - FAULT WARNING LIGHT	2-40
36 - LOW FUEL LEVEL WARNING LIGHT	2-41
37 - GENERATOR BUTTON (OPTION)	2-42
38 - RESET BUTTON SPS (OPTION)	2-42
39 - SAFETY EDGE SPS (OPTION)	2-42
40 - SAFETY CABLE SPS (OPTION)	2-43
41 - HORN	2-43
42 - BATTERY INDICATOR LIGHT (OPTION "STOP AND GO")	2-43

1 - EMERGENCY STOP BUTTON (first version)

⚠ IMPORTANT ⚠

In all cases this control takes priority, even if the movements are executed from the basket control panel or the remote control unit (depending on the model).

Movements may stop suddenly if the emergency stop is activated.

2 positions:

STOP (pressed)

- Press the button to cut off movements and stop the diesel engine

ON (pulled)

- Turn the button a quarter turn to the right and release it

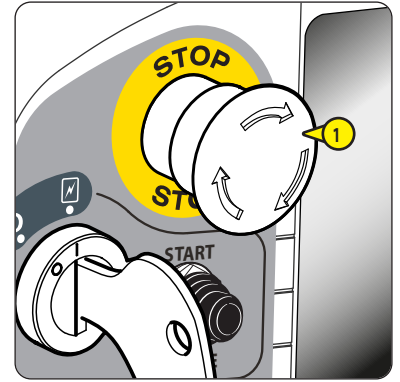

2 - EMERGENCY STOP BUTTON (second and third versions)

⚠ IMPORTANT ⚠

In all cases this control takes priority, even when the movements are executed from the platform control panel or the remote control unit.

Movements may stop suddenly if the emergency stop is activated.

Illustration = third version.

2 positions:

STOP (pressed)

- Press the button to cut off movements and stop the diesel engine

ON (pulled)

- Pull the button or turn it clockwise and release it

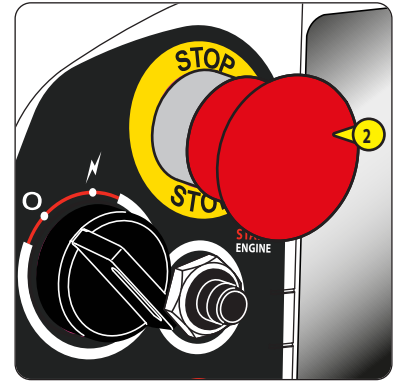

3 - IGNITION SWITCH

Illustrations: #1 = first version, #3 = third version.

2 positions:

 Stop: the control system is turned off. The key can be removed.

 Note: the battery cut-off (option) must be in the off position to turn off the machine.

 On: the control system is turned on. The key cannot be removed.

 Note: the battery cut-off (option) must be in the on position and the 2 emergency stop buttons must be in the on position to start up the machine.

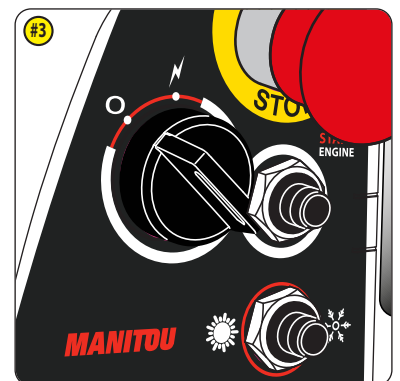
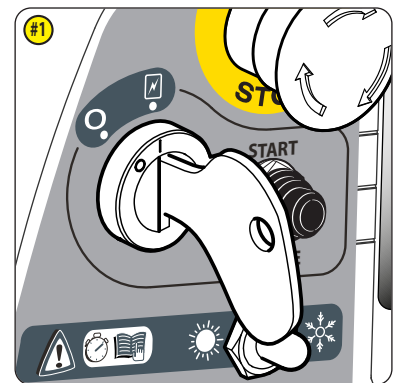

4 - DIESEL ENGINE STARTER BUTTON

⚠ IMPORTANT ⚠

Do not keep the button pressed for more than 15 seconds.

Illustrations: #2 = second version, #3 = third version.

START THE DIESEL ENGINE

- Press and hold down the button
- Release it once the diesel engine has started

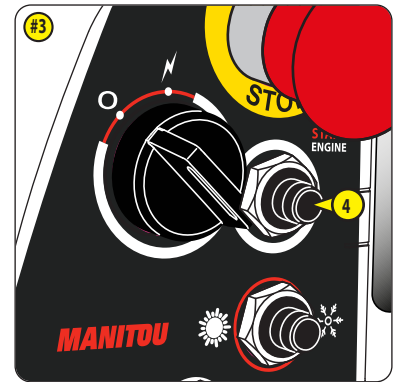
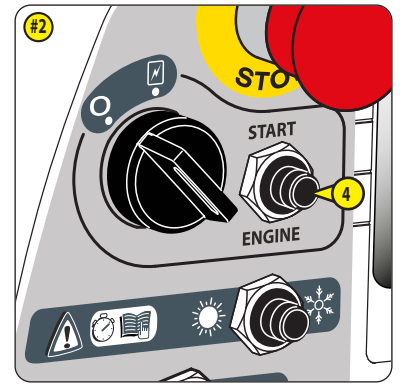



5 - DIESEL ENGINE START MODE SWITCH (first version)

STARTING THE DIESEL ENGINE (ambient temperature above -10 C)

- Put the switch in the  position
- Start the diesel engine

STARTING THE DIESEL ENGINE (ambient temperature below -10 C)

- Put the switch in the  position
- Start the diesel engine
- Wait for 30 to 60 seconds depending on the outside temperature without using the machine's functions
- Put the switch in the  position

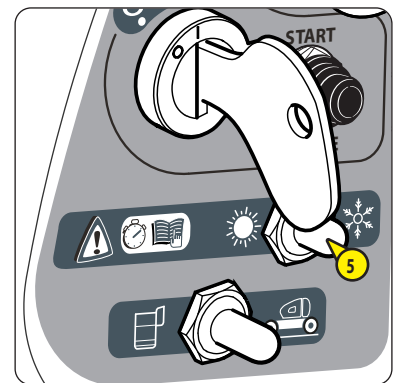

6 - DIESEL ENGINE START MODE BUTTON (second and third versions)

Illustration = third version.

STARTING THE DIESEL ENGINE (ambient temperature below -10 C)

- Press the button 
- Start the diesel engine
- Wait for 30 to 60 seconds depending on the outside temperature without using the machine's functions
- Release the button to restore standard idle



7 - GROUND LEVEL/PLATFORM CONTROLS SELECTOR SWITCH

Illustrations: #2 = second version, #3 = third version.

2 positions:



CONTROLS IN THE PLATFORM

- When the switch is released, the controls in the platform are activated



GROUND CONTROLS

- Push and hold the switch to the right to activate the ground level controls

NOTE: this operating mode is called the "dead man" function.

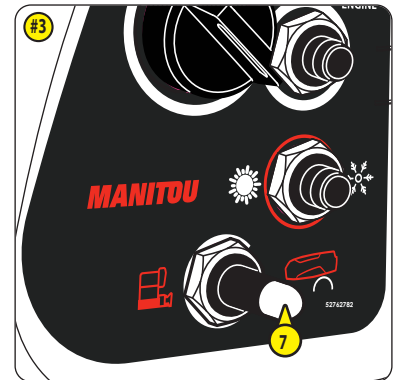
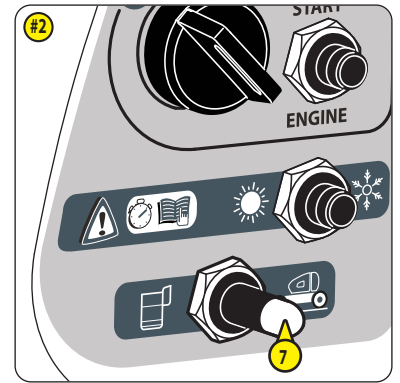

8 - MACHINE MOVEMENT CONTROL KEYS

Illustrations: #1 = first version, #2 = second version, #3 = third version.

- Push and hold the ground level/platform controls selector switch to the right



- Press and hold down the appropriate keys to activate the machine's functions:

- #8A RAISE THE JIB
- #8B LOWER THE JIB
- #8C EXTEND THE TELESCOPE
- #8D RETRACT THE TELESCOPE
- #8E RAISE THE MAIN/SECONDARY ARM
- #8F LOWER THE MAIN/SECONDARY ARM
- #8G TURN THE TURNTABLE TO THE LEFT
- #8H TURN THE TURNTABLE TO THE RIGHT
- #8I TILT THE PLATFORM/JIB UP
- #8J TILT THE PLATFORM/JIB DOWN

- Release the control keys or the controls selector switch to stop the movement(s) in progress.

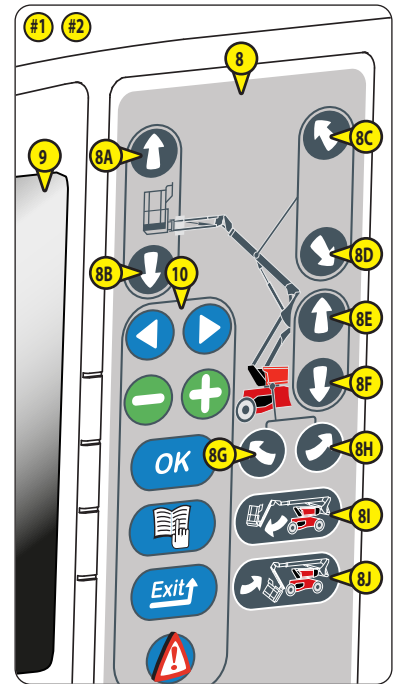

9 - SCREEN

Illustrations: #1 = first version, #2 = second version, #3 = third version.

The screen displays all the start-up steps, the settings and the menus.







NB: GROUND LEVEL CONTROL PANEL SCREEN: DESCRIPTION OF THE DISPLAY.

10 - CONTROL KEYS

Illustrations: #1 = first version, #2 = second version, #3 = third version.

ACTIVATE A CONTROL

- Press and release a control key to activate the corresponding function displayed on the screen #9.

	ARROWS	- Navigate through the menu/sub-menu pages
	PLUS/MINUS	- Navigate through the sub-menu pages or - Change the parameter
	OK	- Confirm a selection or a parameter
	MENU	- Display the MENU PAGE or - Exit a menu/sub-menu and return to the WORK PAGE
	EXIT	- Cancel parameter modification or - Return to the previous sub-menu level
	FAULT	- Display the FAULT CODE/ALARM PAGE

NB: GROUND LEVEL CONTROL PANEL SCREEN: DESCRIPTION OF THE DISPLAY.

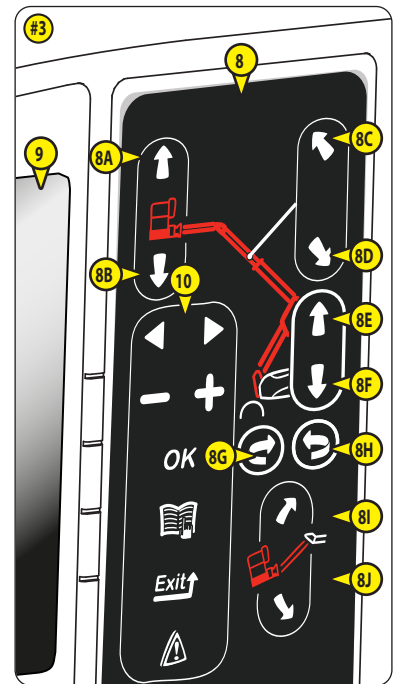

11 - HORN

The horn sounds:

- When the horn button is pressed
- Twice when the machine is turned on without starting the diesel engine in the next 10 seconds, GROUND LEVEL CONTROL PANEL SCREEN - DESCRIPTION OF PAGES: DIESEL ENGINE START CYCLE

ALL MOVEMENTS ALARM option

It sounds intermittently when the machine's functions are activated and when driving/steering the machine, GROUND LEVEL CONTROL PANEL SCREEN - DESCRIPTION OF PAGES: LIST OF MENU.

DRIVING/STEERING ALARM option

It sounds intermittently when driving/steering the machine, GROUND LEVEL CONTROL PANEL SCREEN - DESCRIPTION OF PAGES: LIST OF MENU.

SECONDARY PROTECTION SYSTEM option SPS - FIRST VERSION "SAFEMANSYSTEM":

It sounds intermittently when the system is in alarm mode, OPTIONS.

SECONDARY PROTECTION SYSTEM option SPS - SECOND VERSION:

It sounds intermittently when the system is in alarm mode, OPTIONS.

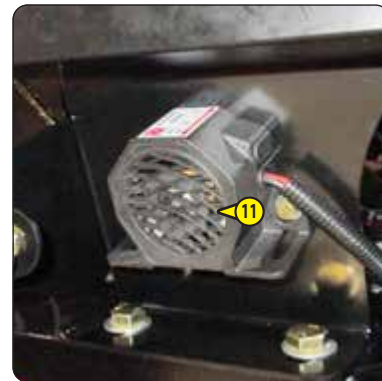

12 - ORANGE ROTATING BEACON LIGHT

PERMANENT ORANGE ROTATING BEACON LIGHT option deactivated

The orange rotating beacon light is lit when the machine's functions are activated and when driving/steering the machine, GROUND LEVEL CONTROL PANEL SCREEN - DESCRIPTION OF PAGES: LIST OF MENU.

PERMANENT ORANGE ROTATING BEACON LIGHT option activated

The orange rotating beacon light is lit when the machine is powered up, GROUND LEVEL CONTROL PANEL SCREEN - DESCRIPTION OF PAGES: LIST OF MENU.

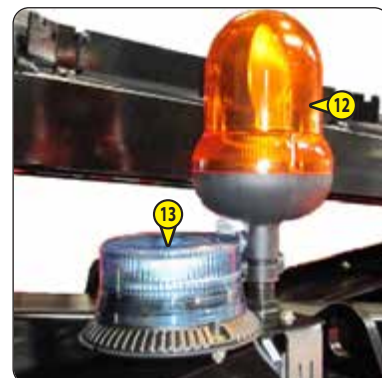

13 - FLASHING LIGHT SPS (OPTION)

 OPTIONS: SECONDARY PROTECTION SYSTEM SPS - FIRST VERSION "SAFEMANSYSTEM" or OPTIONS: SECONDARY PROTECTION SYSTEM SPS - SECOND VERSION.

14 - TILT SENSOR up to machine MAN 00000P01079390

IMPORTANT

*From machine MAN00000K01079391, the tilt sensor is integrated into the ground level control panel
(1 - OPERATING AND SAFETY INSTRUCTIONS: MACHINE MAINTENANCE INSTRUCTIONS)*

An indicator lamp on the tilt sensor indicates its status:

	INDICATOR LAMP	HORN
Maximum authorized tilt not reached	Lit	Stop
Maximum authorized tilt reached	Unlit	Sounds intermittently



15 - PEDAL SWITCH

⚠ IMPORTANT ⚠

Do not press the foot switch when starting the diesel engine.

- Press and hold down the foot switch to activate the controls in the platform

NOTE: this operating mode is called the "dead man" function.

NOTE: no machine functions can be activated if the foot switch is released.

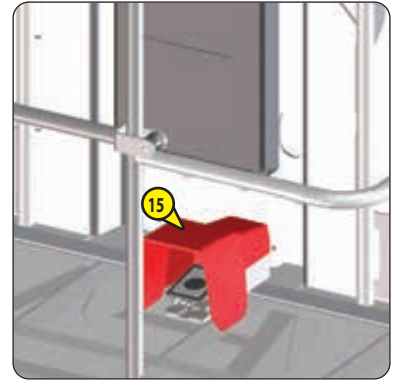

16 - EMERGENCY STOP BUTTON (first version)

⚠ IMPORTANT ⚠

In all cases this control takes priority, except when the movements are executed from the ground control panel or the remote control unit.

Movements may stop suddenly if the emergency stop is activated.

2 positions:

STOP (pressed)

- Press the button to cut off movements and stop the diesel engine

ON (pulled)

- Turn the button a quarter turn to the right and release it

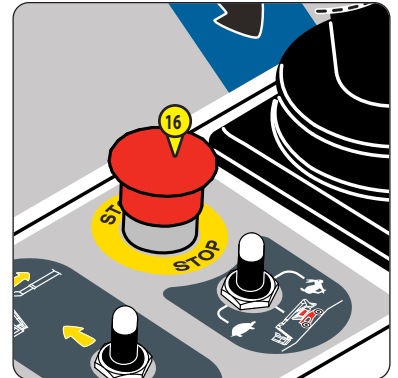

17 - EMERGENCY STOP BUTTON (second version)

⚠ IMPORTANT ⚠

In all cases this control takes priority, except when the movements are executed from the ground control panel or the remote control unit.

Movements may stop suddenly if the emergency stop is activated.

2 positions:

STOP (pressed)

- Press the button to cut off movements and stop the diesel engine

ON (pulled)

- Pull the button or turn it clockwise and release it

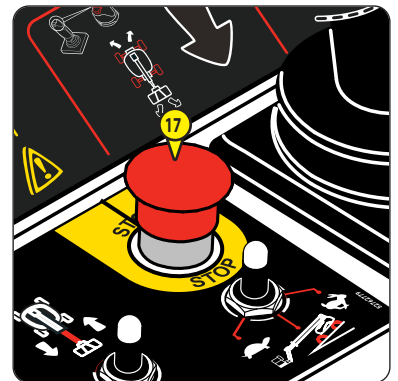

18 - PREHEAT LIGHT (first version)

The indicator light is lit during the diesel engine preheat cycle.
It switches off when the preheat cycle is completed.



19 - PREHEAT LIGHT (second version)

The indicator light is lit during the diesel engine preheat cycle.
It switches off when the preheat cycle is completed.

Option "STOP AND GO"

It flashes when the diesel engine is stopped by the diesel engine automatic stop system "stop and go", \leftarrow OPTIONS: DIESEL ENGINE AUTOMATIC STOP SYSTEM "STOP AND GO".



20 - DIESEL ENGINE STARTER BUTTON

⚠ IMPORTANT ⚠

Do not keep the button pressed for more than 15 seconds.

Illustrations: #1 = first version, #2 = second version.

START THE DIESEL ENGINE

- Press and hold down the button
- Release it once the diesel engine has started

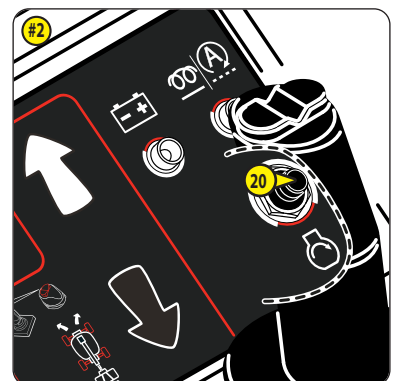
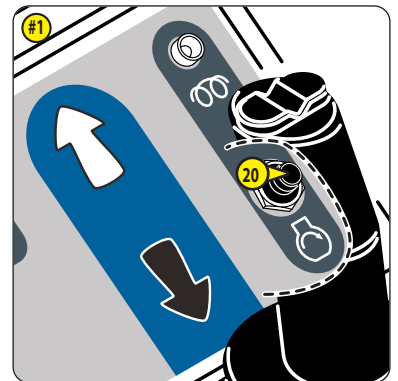

21 - HORN BUTTON

Illustrations: #1 = first version, #2 = second version.

SOUND THE HORN

- Press and hold down the button; release to stop

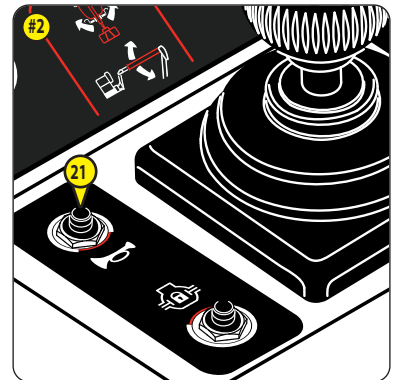
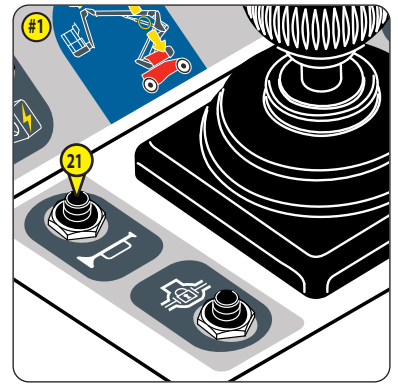

22 - PLATFORM ROTATION SWITCH

Illustrations: #1 = first version, #2 = second version.

- Press and hold down the foot switch

TURN THE PLATFORM TO THE LEFT

- Push and hold the switch to the left
- Release to stop

TURN THE PLATFORM TO THE RIGHT

- Push and hold the switch to the right
- Release to stop

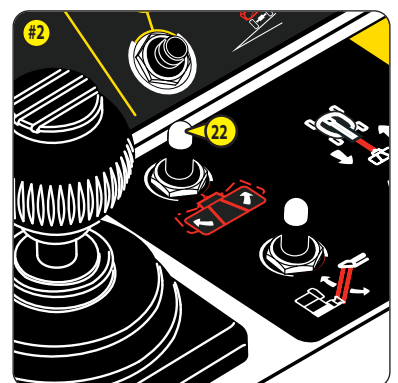
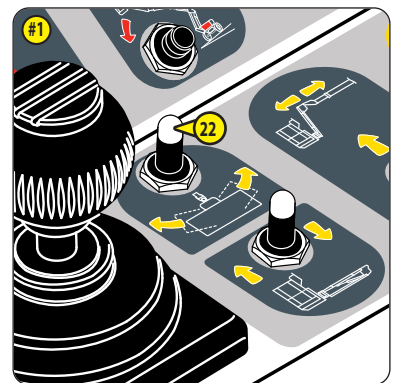

23 - JIB SWITCH

Illustrations: #1 = first version, #2 = second version.

- Press and hold down the foot switch

RAISE THE JIB

- Push and hold the switch downward
- Release to stop

LOWER THE JIB

- Push and hold the switch upward
- Release to stop

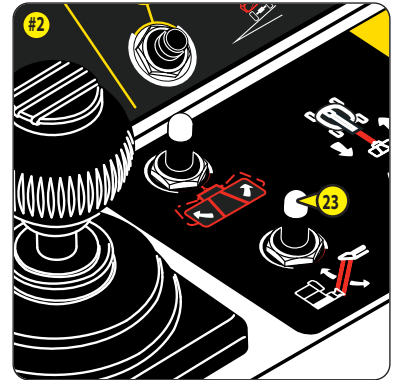
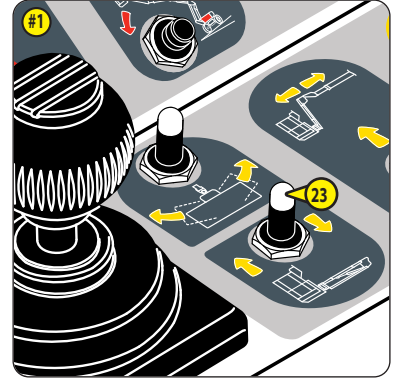

24 - PLATFORM/JIB TILT SWITCH

Illustrations: #1 = first version, #2 = second version.

NOTE: the controls are locked when the machine is in WORKING position, < OPERATING THE MACHINE: TRANSPORT/WORKING POSITION.

- Press and hold down the foot switch

TILT THE PLATFORM/JIB UP

- Push and hold the switch upward
- Release it to stop

TILT THE PLATFORM/JIB DOWN

- Push and hold the switch downward
- Release it to stop

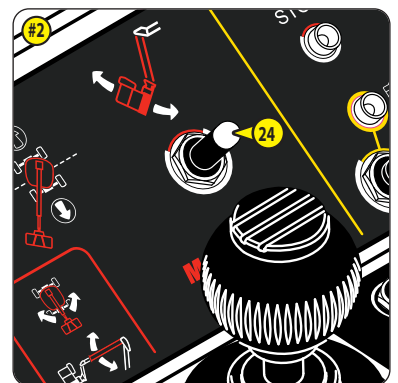
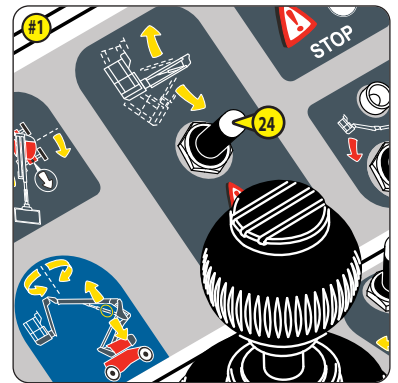

25 - TELESCOPE SWITCH

Illustrations: #1 = first version, #2 = second version.

- Press and hold down the foot switch

EXTEND THE TELESCOPE

- Push and hold the control handle to the left
- Release it to stop

RETRACT THE TELESCOPE

- Push and hold the control handle to the right
- Release it to stop

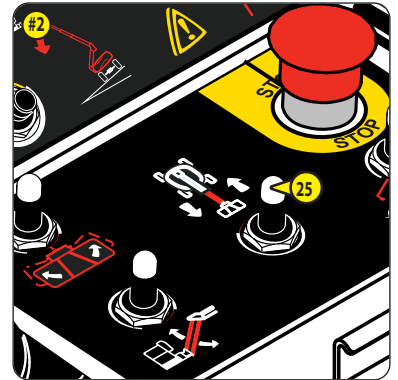
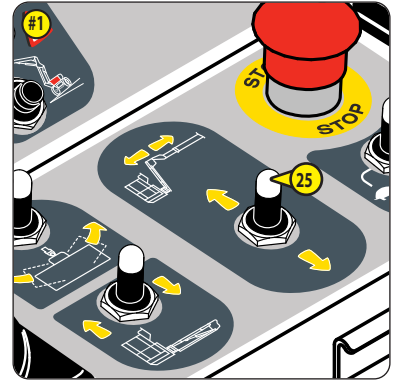

26 - MAIN/SECONDARY ARM AND TURNTABLE CONTROL HANDLE

⚠ IMPORTANT ⚠

The proportional control handle must be operated smoothly, without jerking.

Illustrations: #1 = first version, #2 = second version.

- Press and hold down the foot switch

RAISE THE MAIN/SECONDARY ARM

- Push and hold the control handle forward
- Release it to stop

LOWER THE MAIN/SECONDARY ARM

- Pull and hold the control handle back
- Release it to stop

TURN THE TURNTABLE TO THE LEFT

- Push and hold the control handle to the left
- Release it to stop

TURN THE TURNTABLE TO THE RIGHT

- Push and hold the control handle to the right
- Release it to stop

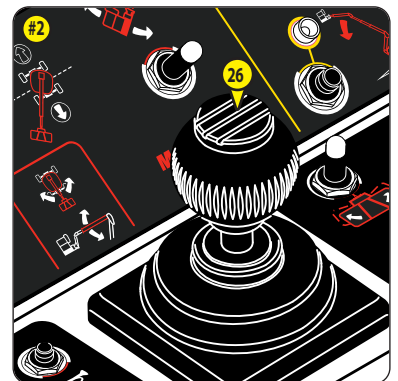
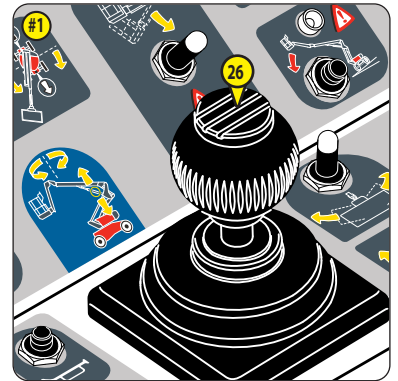

27 - DRIVING/STEERING CONTROL HANDLE

⚠ IMPORTANT ⚠

Always refer to the colors of the arrows on the chassis and on the control panel in the platform before driving/steering the machine.

The proportional control handle must be operated smoothly, without jerking.

Illustrations: #1 = first version, #2 = second version.

- Press and hold down the foot switch
- Press and hold down the trigger **A**

NOTE: the driving/steering functions cannot be activated if the foot switch and/or the trigger are released.

DRIVE FORWARD

- Push and hold the control handle forward

DRIVE BACKWARD

- Pull and hold the control handle back

BRAKE

- Release the control handle (neutral position) to action the brakes

NOTE: the brakes are also actioned when the foot switch and/or the trigger are released.

STEER TO THE LEFT

- Press and hold down the button **B**
- Release it to stop

STEER TO THE RIGHT

- Press and hold down the button **C**
- Release it to stop

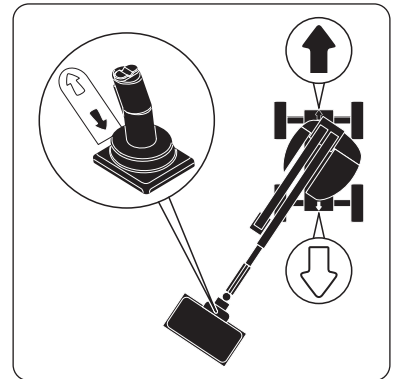
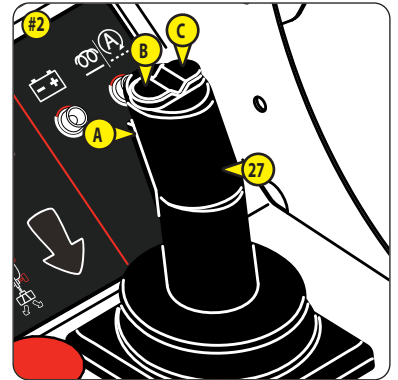
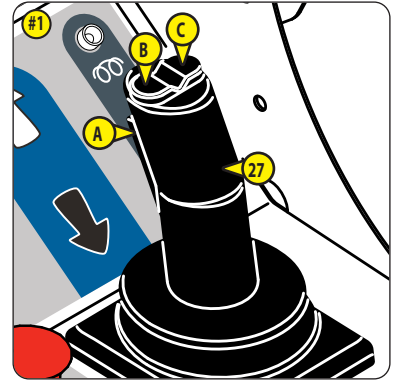

28 - DRIVING SPEED SELECTION SWITCH

⚠ IMPORTANT ⚠

Always brake the machine before selecting the driving speed.

Illustrations: #1 = first version, #2 = second version.

3 positions:



TORTOISE speed for driving the machine at slow speed



RAMP speed for driving the machine at slow speed with full power



HARE speed for driving the machine at high speed



NOTE: driving speed selection only works in the TRANSPORT position, ◀ OPERATING THE MACHINE: TRANSPORT/WORKING POSITION.

NOTE: depending on conditions, restrictions may apply to the speed activated, ◀ OPERATING THE MACHINE: TRANSPORT/WORKING POSITION.

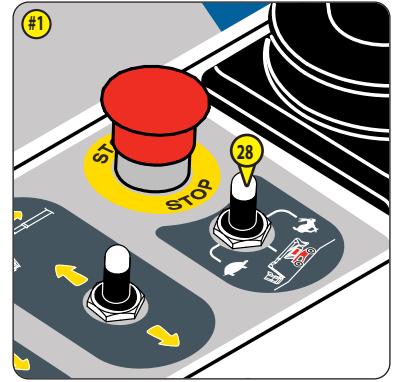

29 - NOT USED

Illustrations: #1 = first version, #2 = second version.

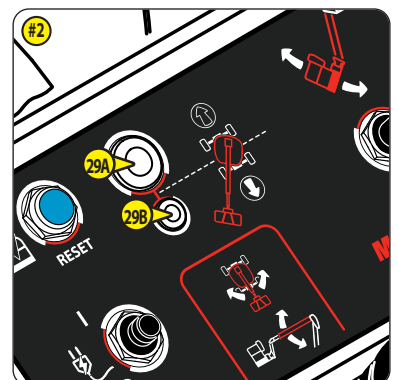
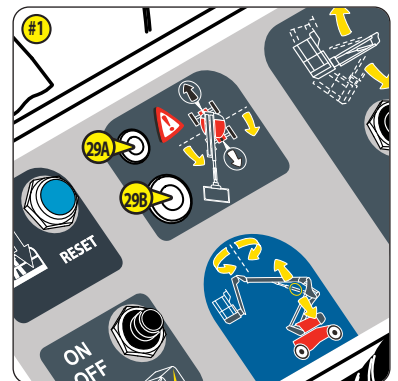

30 - DIFFERENTIAL LOCKING BUTTON

31 - DIFFERENTIAL LOCK WARNING LIGHT

⚠ IMPORTANT ⚠

It is recommended that differential locking be activated/deactivated when the wheels are correctly aligned with the axis of the machine.

Illustrations: #1 = first version, #2 = second version.

MACHINE IN WORKING POSITION

The differential lock is automatically activated when the machine is in the WORKING position; the warning light #28 is on.

MACHINE IN TRANSPORT POSITION

ACTIVATE THE DIFFERENTIAL LOCK

- Press and release the button #27.
Result: the warning light #28 comes on.

DEACTIVATE THE DIFFERENTIAL LOCK

- Press and release the button #27.
Result: the warning light #28 goes out.
- or
- Brake the machine and wait 2 seconds.
Result: the warning light #28 goes out.

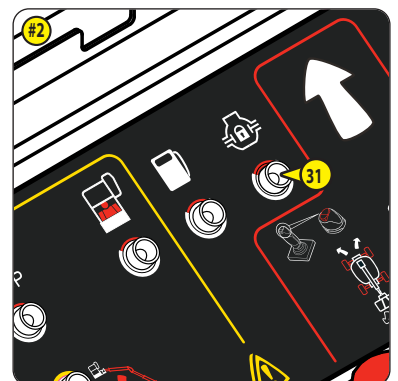
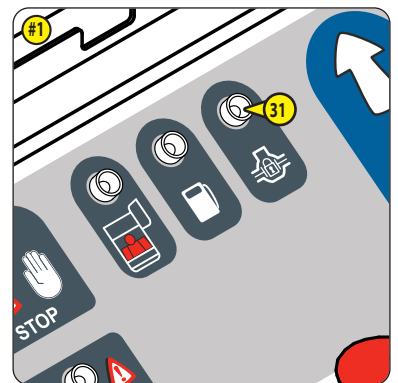
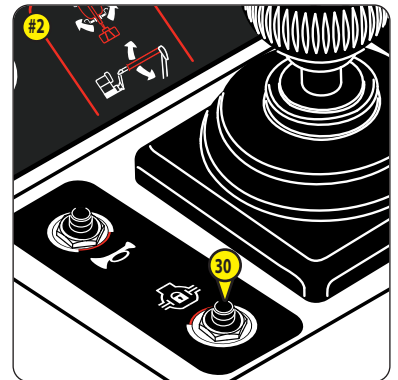
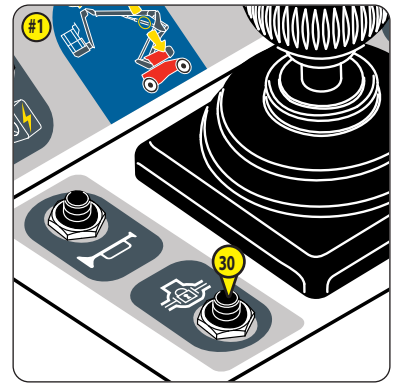

32 - TILT WARNING INDICATOR LAMP

Illustrations: #1 = first version, #2 = second version.

TRIGGERING THE TILT ALARM

It is triggered when the tilt of the chassis is greater than the maximum authorized value:

- The indicator light flashes (On = 0.8 seconds, Off = 0.4 seconds) and the audible alarm sounds intermittently (On = 1 second, Off = 1 second)
- Some functions are locked, OPERATING THE MACHINE: LOCKED FUNCTIONS

STOP THE TILT ALARM AND UNLOCK THE FUNCTIONS (machine in TRANSPORT position)

- 1 - Move the machine to a level surface.

STOP THE TILT ALARM AND UNLOCK THE FUNCTIONS (machine in WORKING position)

- 1 - Fully retract the telescope
- 2 - Fully lower the main/secondary arm
- 3 - Move the machine to a level surface.

33 - USE ON SLOPE BUTTON

⚠ IMPORTANT ⚠

Machine in transport position: use of this function is strictly prohibited.

Machine in working position: the machine could tip over when this function is used. Use with extreme caution.

- Press the button and hold it down to activate the locked functions (except driving forward/backward) when the tilt alarm is activated, TILT ALARM INDICATOR LIGHT.

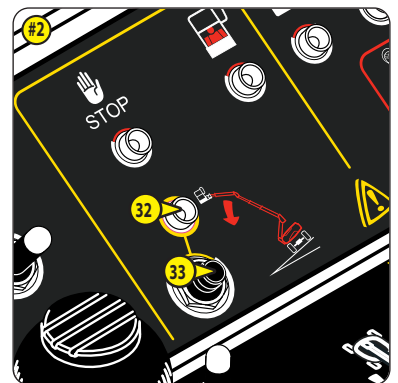

34 - OVERLOAD WARNING INDICATOR LAMP

Illustrations: #1 = first version, #2 = second version.

TRIGGERING THE OVERLOAD ALARM

It is triggered when the load in the platform has reached its maximum capacity:

- The light flashes and the audible warning sounds continuously
- All the machine's functions are locked, OPERATING THE MACHINE: LOCKED FUNCTIONS

STOP THE OVERLOAD ALARM AND UNLOCK THE FUNCTIONS

- Remove the excessive load

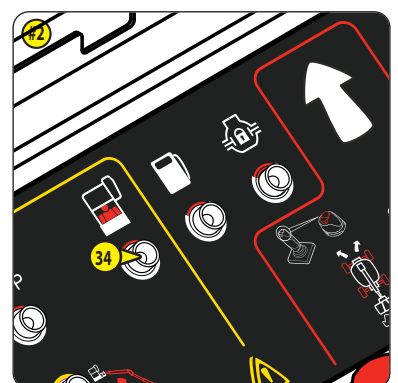
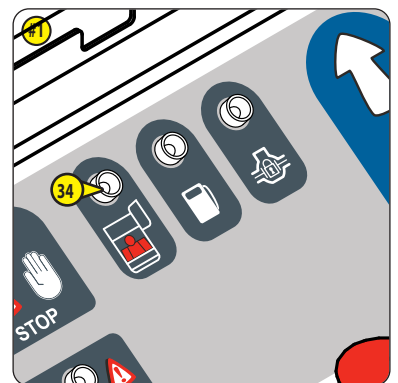

35 - FAULT WARNING LIGHT

⚠ IMPORTANT ⚠

Refer to the maintenance personnel if there is a fault.

Illustrations: #1 = first version, #2 = second version.

NOTE: the light comes on when the machine is turned on and the engine has not been started. It goes off when the engine is started.

The light flashes when a fault is detected:

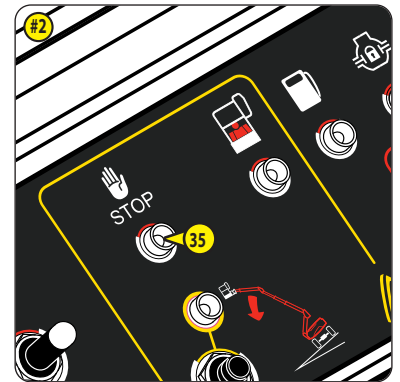
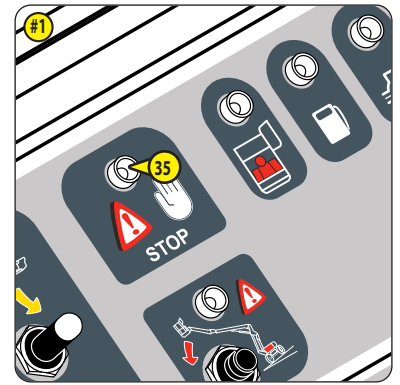

MINOR FAULTS	HORN	
The foot switch or the ground level/platform controls selector switch is blocked	1 beep	Stop using the machine.
The driving/steering control handle trigger is locked		
The sensitive edge SPS, the system sensor SPS or the reset button SPS is blocked (OPTION)	3 beeps repeated every 8 seconds	
The safety cable SPS is slack or cut (OPTION)		
Engine	Sounds intermittently	
Other minor faults	Stop	
MAJOR FAULTS	HORN	
CAN Communication	Stop	All the functions of the machine are locked
Low diesel engine oil pressure	Sounds intermittently	Stop the diesel engine immediately.
High coolant temperature		NOTE: the diesel engine stops after 90 seconds.
Diesel engine overspeed	Stop	The diesel engine stops after 2 seconds.
Proportional control valve	Sounds intermittently	Stop using the machine.
Overload sensor inconsistency		
Diesel engine oil pressure sensor	Stop	
Fuel level very low (level 3)	◀ LOW FUEL LEVEL ALARM LIGHT	

36 - LOW FUEL LEVEL WARNING LIGHT

Illustrations: #1 = first version, #2 = second version.

TRIGGERING THE ALARM

It is triggered when the fuel level is low:

- The light flashes and the audible warning sounds

STOP THE ALARM

- Fill the fuel tank

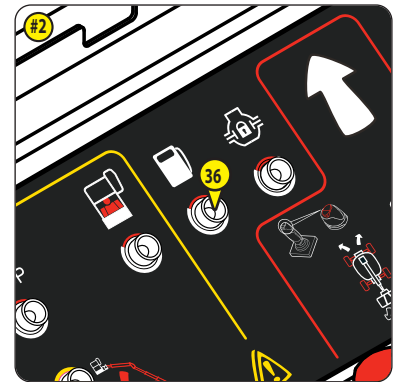
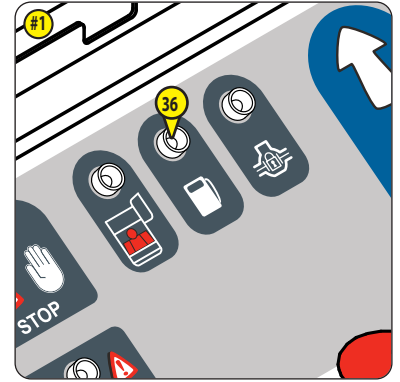

	LOW FUEL LEVEL WARNING LIGHT	HORN
Level 1	On = 0.8 seconds Off = 0.4 seconds	3 beeps (ON = 0.6 seconds, OFF = 0.4 seconds) repeated every 10 minutes
Level 2	On = 0.4 seconds Off = 0.4 seconds	3 beeps (ON = 0.4 seconds, OFF = 0.4 seconds) repeated every minute
Level 3*	On = 0.3 seconds Off = 0.2 seconds	3 beeps (ON = 0.4 seconds, OFF = 0.4 seconds) repeated every 10 seconds

* It is no longer possible to raise the main/secondary arm, extend the telescope, raise the jib, tilt the platform up/down, turn the turntable and turn the platform for more than 2 seconds at a time.

37 - GENERATOR BUTTON (OPTION)

Illustrations: #1 = first version, #2 = second version.

< OPTIONS: GENERATOR.

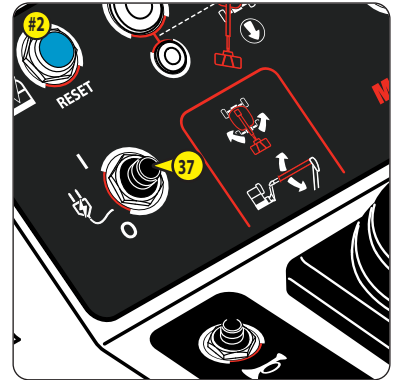
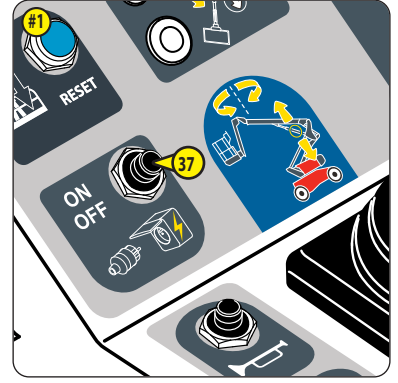

38 - RESET BUTTON SPS (OPTION)

Illustrations: #1 = first version, #2 = second version.

< OPTIONS: SECONDARY PROTECTION SYSTEM SPS - FIRST VERSION "SAFEMANSYSTEM" or < OPTIONS: SECONDARY PROTECTION SYSTEM SPS - SECOND VERSION.

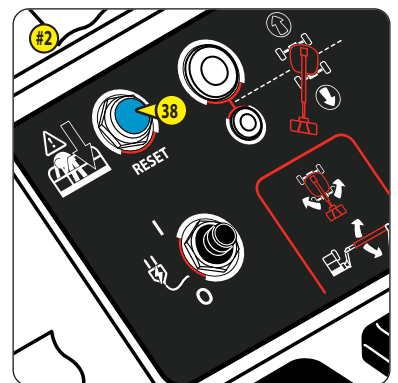
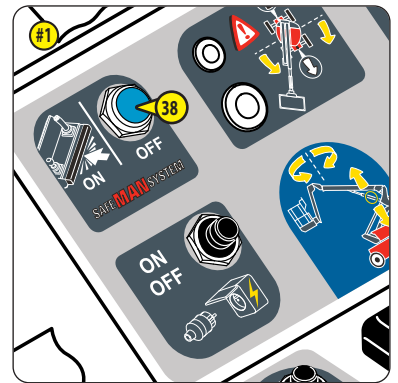

39 - SAFETY EDGE SPS (OPTION)

< OPTIONS: SECONDARY PROTECTION SYSTEM SPS - FIRST VERSION "SAFEMANSYSTEM".

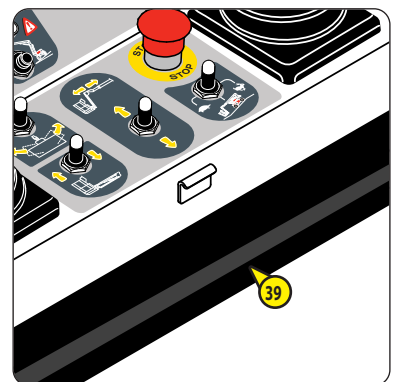

40 - SAFETY CABLE SPS (OPTION)

☞ OPTIONS: SECONDARY PROTECTION SYSTEM SPS - SECOND VERSION.



41 - HORN

The audible alarm sounds:

- Once after the machine has been powered up
- Twice when the functions cannot be activated simultaneously, ☞ OPERATING THE MACHINE.

TILT ALARM

- It sounds intermittently when the tilt of the chassis is greater than the maximum authorized value, ☞ TILT WARNING INDICATOR LIGHT.

OVERLOAD ALARM

- It sounds continuously when the platform has reached maximum capacity, ☞ OVERLOAD WARNING INDICATOR LAMP.

LOW FUEL LEVEL ALARM

- It sounds when the fuel level is low, ☞ LOW FUEL LEVEL WARNING LIGHT.

FAULT ALARM

- It sounds when a fault is detected, ☞ FAULT WARNING LIGHT.



42 - BATTERY INDICATOR LIGHT (OPTION "STOP AND GO")

LOW BATTERY FAULT

It occurs when the diesel engine is automatically stopped by the diesel engine automatic stop system "stop and go" and the battery voltage is low:

- The indicator light comes on.
- The audible alarm sounds intermittently.

React in the event of a low battery fault:

- It is recommended to restart the diesel engine.

Note: ☞ OPTIONS: DIESEL ENGINE AUTOMATIC STOP SYSTEM "STOP AND GO".

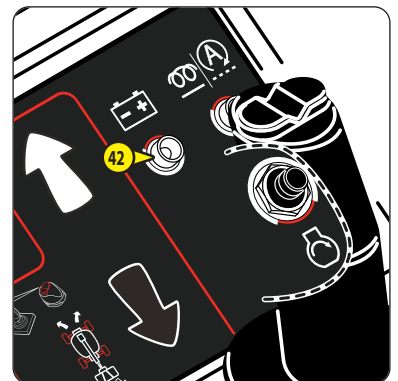

GROUND LEVEL CONTROL PANEL SCREEN

DESCRIPTION OF THE DISPLAY

- ① Current date
- ② Current time
- ③ Vehicle serial number
- ④ Dynamic display area (PAGE)

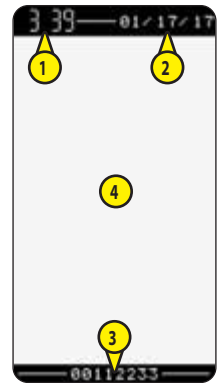

DESCRIPTION OF PAGES

MACHINE POWER-UP CYCLE

When the machine is powered up, the pages ① and ② are displayed one after the other.

① STARTING

- The starting page appears briefly

② PREHEAT

The following are displayed:

- The tachometer of the diesel engine ①
- The battery voltage ②
- The fuel level ③
- The hour counter ④
- The bar graph ⑤:
 - Indicates the progress of the preheating cycle
 - Fills up as the preheating cycle progresses

END OF CYCLE

- If no fault is detected and no alarm is triggered:
 - The DIESEL ENGINE READY TO START PAGE is displayed
 - The audible alarm sounds once
- If a fault is detected:
 - The FAULT PAGE is displayed
- If an alarm is triggered:
 - the corresponding ALARM PAGE is displayed intermittently with the FAULT PAGE or the DIESEL ENGINE READY TO START PAGE

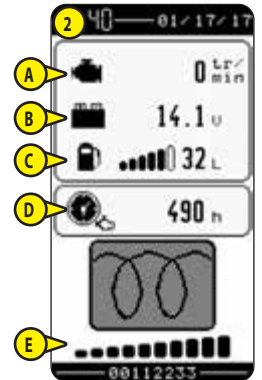

DIESEL ENGINE START CYCLE

At the end of the machine's power-up cycle, if no fault is detected and no alarm is triggered, the page ① is displayed.

① DIESEL ENGINE READY TO START

- Press and hold down the diesel engine starter button
- The PLATFORM CONTROLS WORK PAGE appears
 - The diesel engine has been started
- Release the diesel engine starter button

NOTE: after a certain time, if the diesel engine starter button has not been pressed, the page ② is displayed.

② ALARM PAGE: DIESEL ENGINE NOT STARTED

- The diesel engine start time has been exceeded. The diesel engine is no longer ready to start:

- Turn the ignition switch to position 
- Restart the machine's power-up cycle

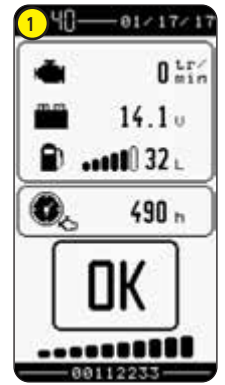

PLATFORM CONTROLS WORK PAGE

It is displayed by default and the platform controls are activated.

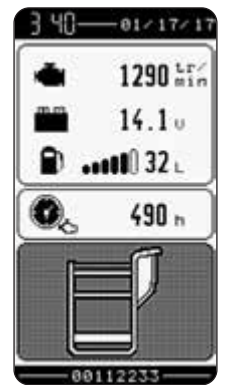

GROUND LEVEL CONTROLS WORK PAGE

It is displayed when the ground level controls are activated.

NB: CONTROL PANEL AND SAFETY DEVICES IN THE PLATFORM: GROUND LEVEL/PLATFORM CONTROLS SELECTOR SWITCH.

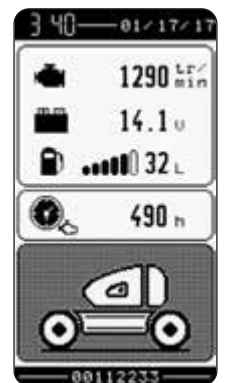

ALERTS

⚠ IMPORTANT ⚠

*Some machine functions can be locked depending on the alert.
Refer to maintenance personnel in the event of an alert.*

1 FAULT PAGE

When a fault is detected:

- The symbol **A** is displayed
- Use the FAULT control key  to display the corresponding FAULT CODE/ALARM PAGE

2 ALARM PAGE

When an alarm is triggered:

- The symbol **A** and the image **B** are displayed intermittently with the WORK PAGE or the FAULT PAGE
- Resolve the problem to stop the alarm or use the FAULT control key  to display the corresponding FAULT CODE/ALARM PAGE

NOTE: the illustrations **2A** and **2B** show 2 examples of alarms.

3 FAULT/ALARM CODE PAGE

When a fault or an alarm is triggered and the FAULT control key  is used:

- The fault code/alarm **C** and its description **D** are displayed
- Resolve the problem then use the control key OK  so that the fault or alarm is no longer displayed
 - This action is recorded in the faults history

NOTE: the illustration **3** shows an example of a fault code.

4 MAINTENANCE WARNING

⚠ IMPORTANT ⚠

If the maintenance warning (key ) is displayed, refer to maintenance personnel.

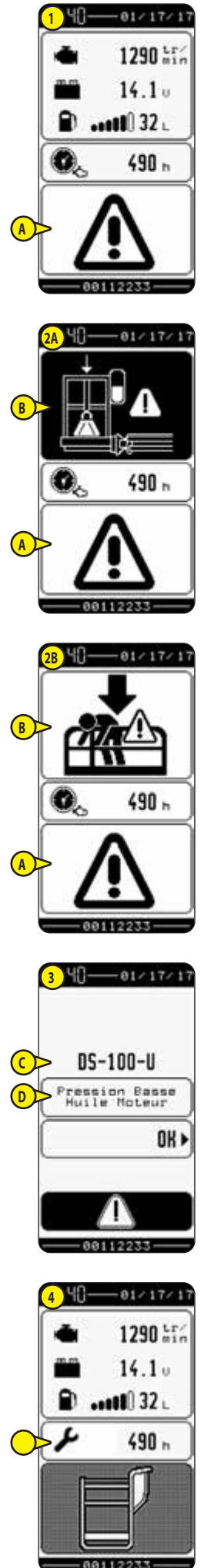

NAVIGATING THE MENUS

NB: < LIST OF MENUS

ACCESS TO THE MAIN MENU

- Use the MENU control key 

Result:

- The page ① is displayed with the list of menus/sub-menus

ACCESSING A MENU FROM THE MAIN MENU

- Use the ARROW control keys   to select the desired menu
- Use the control key OK  to confirm the selection

Result:

- The menu contents appear

ACCESSING A SUB-MENU FROM THE MAIN MENU

- Use the MINUS/PLUS keys   to select the desired sub-menu
- Use the control key OK  to confirm the selection

Result:

- The content of the sub-menu is displayed

ACCESSING A SUB-MENU FROM A MENU

- Use the ARROW control keys   to select the desired sub-menu
- Use the control key OK  to confirm the selection

Result:

- The content of the sub-menu is displayed

MODIFYING A PARAMETER IN A MENU OR SUB-MENU

- Use the MINUS/PLUS keys   to modify the parameter
- Use the control key OK  to confirm the modification

Result:

- A confirmation message is displayed

- Use the control key OK  to confirm the modification

RETURNING TO THE PREVIOUS MENU

- Use the control key EXIT 

RETURNING TO THE MAIN MENU FROM A MENU OR SUB-MENU

- Use the MENU control key 

Result:

- The page ① is displayed with the list of menus/sub-menus

RETURNING TO THE WORK PAGE FROM THE MAIN MENU



- Use the MENU control key. 

Result:

- The WORK PAGE is displayed



LIST OF MENUS

	Menus/sub-menus	Username		Dealers/Rental companies		
		Access code not required		Access code required		
		Display	Adjustment of parameters	Display	Adjustment of parameters	
	"Code" Code		<input type="radio"/>		<input type="radio"/>	
	"Options" Options	"Klaxon mode" Horn mode (1)		<input type="radio"/>	<input type="radio"/>	
		"Always flash. light" Permanent rotating beacon light (2)		<input type="radio"/>	<input type="radio"/>	
		"Locking telescop" Telescope locking			<input type="radio"/>	
		"Drive in working mode" Travel when working			<input type="radio"/>	
		"Tilt in working mode" Tilting when working (*)			<input type="radio"/>	
		"Safe Man System" Safe Man System (*) or "Sec. Guarding System" Secondary protection system (*)			<input type="radio"/>	
		"Auto retract tel. (SMS)" Automatic telescope retraction (SMS) (3)			<input type="radio"/>	
		"Reduce speed fast + bkwd" Reversing speed + hare reduction			<input type="radio"/>	
		"Easy manager" (*) or "Easy Link remote ctrl" Easy link remote control (*)			<input type="radio"/>	
		"Box config Easy manager" Easy Manager configuration (*) or "Easy Link keypad ctrl" Easy link keyboard control (*)			<input type="radio"/>	
		"Language" Language	English			<input type="radio"/>
			Deutsch			<input type="radio"/>
	Nederlands				<input type="radio"/>	
	English				<input type="radio"/>	
	"System parameters" System parameters	"Engine management" Engine management			<input type="radio"/>	
		"Arm management" Jib management			<input type="radio"/>	
		"Arm bumper" Jib stop			<input type="radio"/>	
		"Telescop management" Telescope management			<input type="radio"/>	
		"Telescop bumper" Telescope stop			<input type="radio"/>	
		"Jib management" Jib management			<input type="radio"/>	
		"Turret management" Turntable management			<input type="radio"/>	
		"Bskt levell mgmt" Basket tilting management			<input type="radio"/>	
		"Bskt rotation mgmt" Basket rotation management			<input type="radio"/>	
		"Steering management" Steering management			<input type="radio"/>	
		"Generator" Generator			<input type="radio"/>	
		"Maint periods" Maintenance periods			<input type="radio"/>	
	"USB download" USB transfer			<input type="radio"/>		

(*) depending on version

(1) "NONE" = NONE, "AVCT" = DRIVING/STEERING ALARM, "MVT" = ALL MOVEMENTS ALARM

(2) PERMANENT ORANGE ROTATING BEACON LIGHT: "OFF" = deactivated, "ON" = activated



(3) Depending on version, AUTOMATIC TELESCOPE RETRACTION: "OFF" = deactivated, "ON" = activated

NOTE: the texts in inverted commas are displayed when the language "English" (English) is selected.

	Menus/sub-menus		Username		Dealers/Rental companies	
			Access code not required		Access code required	
			Display	Adjustment of parameters	Display	Adjustment of parameters
	"Maintenance" Maintenance	"Oil change" Oil change (6)	⊙			⊙
		"Oil filter" Oil filter (6)	⊙			⊙
		"Air filter" Air filter (6)	⊙			⊙
		"Fuel filter" Fuel filter (6)	⊙			⊙
		"Hydraulic filter" Hydraulic filter (6)	⊙			⊙
		"Hydrostat filter" Hydrostatic filter (6)	⊙			⊙
		"Lubrication" Lubrication (6)	⊙			⊙
		"Mechanical check" Mechanical inspection (6)	⊙			⊙
	"Maintenance History" Maintenance history			⊙		
	"Speed calibration" Speed calibration	"Arm lifting up" Jib raising				⊙
		"Arm lifting down" Jib lowering				⊙
		"Extend telescop" Telescope extension				⊙
		"Retrac telescop" Telescope retraction				⊙
		"Jib lifting up" Jib up				⊙
		"Jib lifting down" Jib down				⊙
		"Rotation turret" Turntable rotation				⊙
		"Basket right rotation" Platform right rotation				⊙
		"Basket left rotation" Platform left rotation				⊙
		"Forward drive working mode" Work forward travel			⊙	
		"Backward drive working mode" Working reverse travel			⊙	
		"Forward drive slow transport" Slow (tortoise) forward travel			⊙	
		"Backward drive slow transport" Slow (tortoise) backward travel			⊙	
		"Forward drive slope transport" Ramp forward travel			⊙	
	"Backward drive slope transport" Ramp backward travel			⊙		
		"Pressure setting" Pressure adjustments				⊙
		"Overload calibration" Overload calibration				⊙
		"Generator calibration" Generator calibration				⊙
"Parameters setting" Parameter management	"Mach parameters restoration" Restore machine parameters				⊙	
	"Mach parameters saving" Save machine parameters				⊙	
	"Raw factory prm restoration" Restore basic factory values				⊙	
	"Engine accel calibration" Engine acceleration calibration				⊙	
	"Joysticks calibration" Joystick calibration				⊙	
"Mvt start calibration" Movement start calibration	"Arm lifting down" Arm lowering				⊙	
	"Retract telescop" Telescope retraction				⊙	
	"Jib lifting down" Jib down				⊙	
	"Forward drive working mode" Work forward travel				⊙	

(6) "at / to do in / urgent" = in / to do / urgent

NOTE: the texts in inverted commas are displayed when the language "English" (English) is selected.

	Menus/sub-menus		Username		Dealers/Rental companies	
			Access code not required		Access code required	
			Display	Adjustment of parameters	Display	Adjustment of parameters
	"Screen setting" Screen adjustments	"Contrast" Contrast		<input type="radio"/>		<input type="radio"/>
		"Brightness" Light level		<input type="radio"/>		<input type="radio"/>
		"Date and time" Date and time		<input type="radio"/>		<input type="radio"/>
		"Button tones" Key beeps		<input type="radio"/>		<input type="radio"/>
	"Codification" Codification	"Program and equipment codes" Program and equipment codes	<input type="radio"/>		<input type="radio"/>	
		"Machine selection" Machine selection				<input type="radio"/>
	"Hour counters" Hour counters	"Rental" Rental	<input type="radio"/>			<input type="radio"/>
		"Engine" Engine	<input type="radio"/>		<input type="radio"/>	
	"Day hours" Daily hours		<input type="radio"/>		<input type="radio"/>	
	"Input/output visualisation" Input/output display	"Power supply" Power supplies	<input type="radio"/>		<input type="radio"/>	
		"Fuses" Fuses	<input type="radio"/>		<input type="radio"/>	
		INTOR UC233	<input type="radio"/>		<input type="radio"/>	
		INANA UC233	<input type="radio"/>		<input type="radio"/>	
		HSCE UC233	<input type="radio"/>		<input type="radio"/>	
		OUTTOR UC233	<input type="radio"/>		<input type="radio"/>	
		OUTPWM UC233	<input type="radio"/>		<input type="radio"/>	
	"Diagnostic" Diagnostics	"Lifting arm" Jib raising	<input type="radio"/>		<input type="radio"/>	
		"Lowering arm" Jib lowering	<input type="radio"/>		<input type="radio"/>	
		"Telescope extend" Telescope extension	<input type="radio"/>		<input type="radio"/>	
		"Telescope retract" Telescope retraction	<input type="radio"/>		<input type="radio"/>	
		"Lifting jib" Jib up	<input type="radio"/>		<input type="radio"/>	
		"Lowering jib" Jib down	<input type="radio"/>		<input type="radio"/>	
		"Turret rotation" Turntable rotation	<input type="radio"/>		<input type="radio"/>	
		"Lifting basket tilt" Platform tilt lifting	<input type="radio"/>		<input type="radio"/>	
		"Lowering basket tilt" Platform tilt lowering	<input type="radio"/>		<input type="radio"/>	
		"Basket rotation" Platform rotation	<input type="radio"/>		<input type="radio"/>	
"Driving" Machine travel		<input type="radio"/>		<input type="radio"/>		
"Steering" Machine steering		<input type="radio"/>		<input type="radio"/>		
"Generator activation" Generator activation		<input type="radio"/>		<input type="radio"/>		
"Engine starter" Engine starting		<input type="radio"/>		<input type="radio"/>		
"Defaults history" Fault history		<input type="radio"/>		<input type="radio"/>		

NOTE: the texts in inverted commas are displayed when the language "English" (English) is selected.

OPERATING THE MACHINE

⚠ IMPORTANT ⚠

Part 1 - OPERATING AND SAFETY INSTRUCTIONS must be read and understood before operating the machine.

TRANSPORT/WORKING POSITION

TRANSPORT POSITION

The machine is in the TRANSPORT position when:

- The main/secondary arm is completely lowered
- The telescope is completely retracted

NOTE: the jib may or may not be raised, the turntable and the platform may or may not be turned.







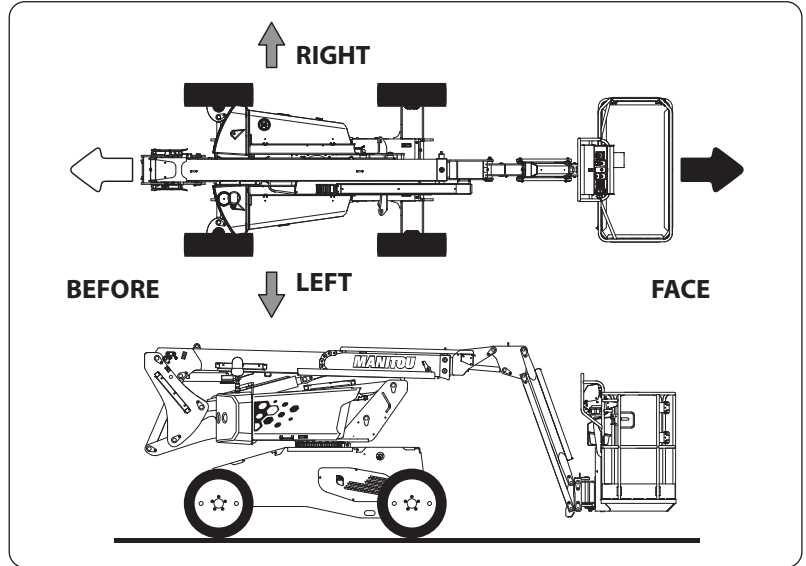

The turntable and the platform are in NEUTRAL position when the main/secondary arm and the platform are parallel to the machine's chassis with the platform between the 2 rear wheels.

Front, rear, left and right are defined as follows:

- The machine is in the TRANSPORT position
- The turntable and the platform are in NEUTRAL position
- The operator is in the platform facing the direction of the front wheels



The TORTOISE, RAMP and HARE driving speeds can be selected but restrictions may apply.

	 TORTOISE speed selected	 RAMP speed selected	 HARE speed selected
Drive forward	 TORTOISE speed activated	 RAMP speed activated	 HARE speed activated*
Drive backward	 TORTOISE speed activated	 RAMP speed activated	 RAMP speed activated

*: RAMP speed is automatically activated when the differential lock is activated.

NOTE: it is recommended that the turntable and platform are put in NEUTRAL position to drive the machine at HARE speed.

WORKING POSITION

⚠ IMPORTANT ⚠

Traveling over rough terrain, on unstable ground, on slopes that are steeper than those authorized (⚠ SPECIFICATIONS) or in any other conditions likely to cause the machine to tip up or become destabilized is PROHIBITED.

The machine is in the WORKING position when:

- The main/secondary arm is not completely lowered
- The telescope is not completely retracted

NOTE: the jib may or may not be raised. The turntable and the platform may or may not be turned.

The WORKING POSITION driving speed is automatically activated regardless of the driving speed selected.

The differential lock is automatically activated regardless of the driving speed selected.

DRIVING CONDITIONS

DRIVING LONG DISTANCES

- The machine is in the TRANSPORT position
- The turntable and the platform are in NEUTRAL position
- The jib is slightly raised for better visibility
- Drive the machine forward

DRIVING ON A SLOPE

- The machine is in the TRANSPORT position
- The turntable and the platform are in NEUTRAL position
- The jib is slightly raised for better visibility

- Select RAMP speed



- Drive the machine in line with the slope

OPERATION FROM THE GROUND LEVEL CONTROL PANEL

⚠ IMPORTANT ⚠

◀ **CONTROL PANEL AND SAFETY DEVICES ON THE GROUND** for detailed information about the ground controls.

SWITCH ON THE MACHINE

- Ensure that the emergency stop buttons are pulled (ON position)
 - On the ground level control panel
 - On the platform control panel
- BATTERY CUT-OFF option: turn the battery cut-off to the ON position
- Turn the ignition switch to position 

Result:

- The screen comes on, ▶ GROUND LEVEL CONTROL PANEL SCREEN

NOTE: SECONDARY PROTECTION SYSTEM option SPS - FIRST VERSION "SAFEMANSYSTEM", ▶ OPTIONS.

NOTE: SECONDARY PROTECTION SYSTEM option SPS - SECOND VERSION, ▶ OPTIONS.

NOTE: the horn sounds twice and the DIESEL ENGINE NOT STARTED alarm page is displayed when the machine is turned on without starting the diesel engine in the next 10 seconds, ▶ GROUND LEVEL CONTROL PANEL SCREEN.

SWITCH OFF THE MACHINE

- Turn the ignition switch to position 
- BATTERY CUT-OFF option: turn the battery cut-off to the OFF position

START THE DIESEL ENGINE

- Switch the machine on
- Wait for the preheat cycle to finish, ▶ GROUND LEVEL CONTROL PANEL SCREEN
- Start the diesel engine, ▶ DIESEL ENGINE STARTER BUTTON and ▶ DIESEL ENGINE START MODE BUTTON if the outside temperature is below -10 °C
- If the diesel engine does not start:

- Turn the ignition switch to position  , turn it to position 
- Wait for the preheat cycle to finish and try to start the diesel engine

NOTE: consult maintenance personnel if the diesel engine fails to start after several attempts.

SWITCH OFF THE DIESEL ENGINE

⚠ IMPORTANT ⚠

Wait several minutes for the diesel engine to cool down before stopping it after intensive use.

- Turn the ignition key to position  or press the emergency stop button (OFF position)

POSITION THE PLATFORM

- Ensure that the turntable is unlocked, ▶ SAFETY COMPONENTS: TURNTABLE LOCKING PIN.

NOTE: it is essential that the turntable is locked when the machine is being transported or lifted, ▶ TRANSPORTING THE MACHINE and ▶ 3 - MAINTENANCE: OCCASIONAL OPERATIONS: RAISING THE MACHINE.

- Push and hold the ground level/platform controls selector switch to the right 
- Use the appropriate controls to position the platform
- Release the ground level/platform controls selector switch

ACTIVATE SIMULTANEOUS FUNCTIONS

2 machine functions can be activated simultaneously. The audible warning sounds twice when the machine's functions cannot be activated simultaneously.

EMERGENCY STOP

- Press the emergency stop button (OFF position)

USE FROM THE PLATFORM CONTROL PANEL

⚠ IMPORTANT ⚠

◀ **CONTROL PANEL AND SAFETY DEVICES IN THE PLATFORM** for detailed information about the platform controls.

Make sure that the platform is level before putting the machine in WORKING position, ◀ TRANSPORT/WORKING POSITION.

TURNTABLE COVER KEY LOCK option: to guarantee access to the emergency controls, it is mandatory to unlock the right-hand turntable cover before using the machine from the platform.

TURN THE MACHINE ON/OFF

◀ OPERATION FROM THE GROUND LEVEL CONTROL PANEL.

START THE DIESEL ENGINE

- Switch the machine on
- Wait for the preheat cycle to finish, ◀ PREHEAT INDICATOR LIGHT
- Start the diesel engine, ◀ DIESEL ENGINE STARTER BUTTON

NB: ◀ OPERATION FROM THE GROUND LEVEL CONTROL PANEL if the outside temperature is below -10 °C.

- If the diesel engine does not start:
 - Press the emergency stop button (OFF position), pull it or turn it clockwise and then release it (ON position).
 - Wait for the preheat cycle to finish and try to restart the diesel engine

NOTE: consult maintenance personnel if the diesel engine fails to start after several attempts.

SWITCH OFF THE DIESEL ENGINE

⚠ IMPORTANT ⚠

Wait several minutes for the diesel engine to cool down before stopping it after intensive use.

- Press the emergency stop button (OFF position)

DRIVE, STEER AND BRAKE THE MACHINE

⚠ IMPORTANT ⚠

Always refer to the colors of the arrows on the chassis and on the control panel in the platform before driving/steering the machine.

- Ensure that the turntable is unlocked, ◀ SAFETY COMPONENTS: TURNTABLE LOCKING PIN

NOTE: it is essential that the turntable is locked when the machine is being transported or lifted, ◀ TRANSPORTING THE MACHINE and ◀ 3 - MAINTENANCE: OCCASIONAL OPERATIONS: RAISING THE MACHINE.

- Put the driving speed selection switch into the desired speed position
- Put the driving speed selection switch into the desired steering position
- Press and hold down the foot switch
- Use the appropriate control handle to drive, steer and brake the machine
- Release the foot switch

POSITION THE PLATFORM

- Ensure that the turntable is unlocked, ◀ SAFETY COMPONENTS: TURNTABLE LOCKING PIN

NOTE: it is essential that the turntable is locked when the machine is being transported or lifted, ◀ TRANSPORTING THE MACHINE and ◀ 3 - MAINTENANCE: OCCASIONAL OPERATIONS: RAISING THE MACHINE.

- Press and hold down the foot switch
- Use the appropriate controls to position the platform
- Release the foot switch

ACTIVATE SIMULTANEOUS FUNCTIONS

3 machine functions can be activated simultaneously. The audible warning sounds twice when the machine's functions cannot be activated simultaneously

EMERGENCY STOP

- Press the emergency stop button (OFF position)

LOCKED FUNCTIONS



















Some functions are locked  (refer to the tables below):

- When the platform load has reached maximum capacity (OVERLOAD ALARM)
- If the tilt of the chassis is greater than the maximum authorized value (TILT WARNING)

TRANSPORT POSITION

	ALARM	
	OVERLOAD	TILTING
GROUND FUNCTIONS		
RAISE THE MAIN/SECONDARY ARM		
EXTEND THE TELESCOPE		
RAISE/LOWER THE JIB		
TILT THE PLATFORM/JIB UP/DOWN		
TURN THE TURNTABLE (LEFT/RIGHT)		
FUNCTIONS IN THE PLATFORM		
RAISE THE MAIN/SECONDARY ARM		
EXTEND THE TELESCOPE		
RAISE/LOWER THE JIB		
TILT THE PLATFORM/JIB UP/DOWN		
TURN THE TURNTABLE (LEFT/RIGHT)		
TURN THE PLATFORM (LEFT/RIGHT)		
DRIVE (FORWARD/BACKWARD)		
STEER (LEFT/RIGHT)		

WORKING POSITION

	ALARM	
	OVERLOAD	TILTING
GROUND FUNCTIONS		
RAISE THE MAIN/SECONDARY ARM		
LOWER THE MAIN/SECONDARY ARM		
EXTEND/RETRACT THE TELESCOPE		
RAISE/LOWER THE JIB		
TILT THE PLATFORM/JIB UP/DOWN		
TURN THE TURNTABLE (LEFT/RIGHT)		
FUNCTIONS IN THE PLATFORM		
RAISE THE MAIN/SECONDARY ARM		
LOWER THE MAIN/SECONDARY ARM		
EXTEND THE TELESCOPE		
RETRACT THE TELESCOPE		
RAISE/LOWER THE JIB		
TURN THE TURNTABLE (LEFT/RIGHT)		
TURN THE PLATFORM (LEFT/RIGHT)		
DRIVE (FORWARD/BACKWARD)		
STEER (LEFT/RIGHT)		

CONFIGURE THE MACHINE FOR TRANSPORT

⚠ IMPORTANT ⚠

Turntable rotation is prohibited once on the flatbed.

It is essential that the turntable remains locked when the platform is on the flatbed, ⚠ SAFETY COMPONENTS: TURNABLE LOCKING PIN.

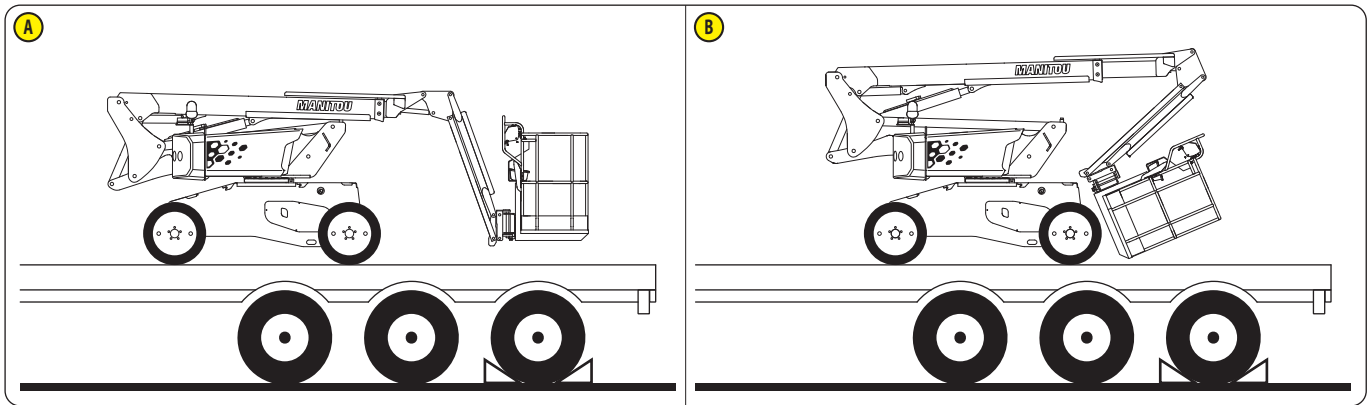

The machine must be transported in TRANSPORT position **A** or in FOLDED position **B**.

NB: ⚠ OPERATING THE MACHINE: TRANSPORT/WORKING POSITION: TRANSPORT POSITION.

MOVING FROM TRANSPORT POSITION **A** TO FOLDED POSITION **B**

NOTE: the diesel engine is started; the machine is in the TRANSPORT position; the turntable and the platform are in the NEUTRAL position and the turntable is locked.

- Fully lower the jib
- Get out of the platform
- From the ground level control panel:
 - Raise the main/secondary arm (15° maximum)
 - Extend the telescope slightly
 - Tilt the platform/jib down to fold the platform under the main/secondary arm. Ensure that the platform cannot hit the transport flatbed or the machine's chassis
 - Lower the main/secondary arm so that the platform is approximately 10 cm from the transport flatbed
 - Switch off the machine and remove the key

MOVING FROM THE FOLDED POSITION **B** TO THE TRANSPORT POSITION **A**

NOTE: the turntable is locked.

- From the ground level control panel:
 - Start the diesel engine
 - Raise the main/secondary arm (15° maximum)
 - Tilt the platform/jib up until the platform floor is horizontal. Ensure that the platform cannot hit the transport flatbed
 - Fully retract the telescope
 - Fully lower the main/secondary arm
- Switch the machine off

⚠ IMPORTANT ⚠

Turntable rotation is prohibited once on the flatbed.

It is essential that the turntable remains locked when the platform is on the flatbed, ⚠ SAFETY COMPONENTS: TURNTABLE LOCKING PIN.

Make sure that the machine is properly secured to the transport flatbed.

The machine is equipped with 6 anchoring points (⚠ STICKERS: ANCHORAGE POINT); comply with the country's regulations concerning the minimum number of anchorage points required when transporting a machine.

Make sure that the platform is properly secured to the transport flatbed

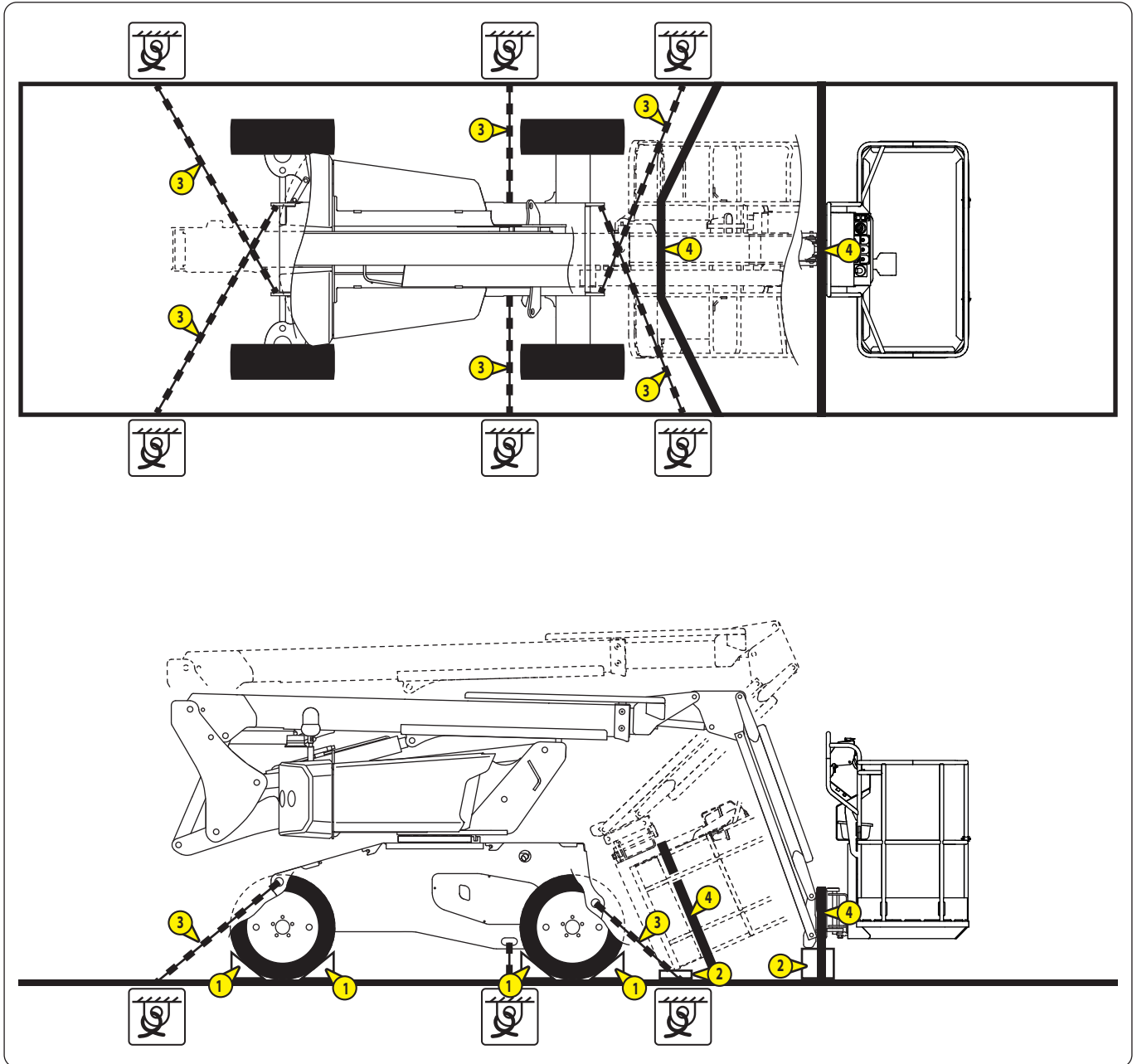

- Ensure that the machine is switched off: The ignition switch must be in the  position, the key must be removed and the battery cut-off (option) must be in the OFF position.
- Ensure that the turntable is locked, ⚠ SAFETY COMPONENTS: TURNTABLE LOCKING PIN
- Fix chocks **1** to the transport flatbed at the front and rear of each of the machine's wheels
- Install a wedge **2** under the machine platform
- Lash the machine to the flatbed truck with sufficiently robust straps or chains **3** (according to country regulations) attached to the machine's anchorage points (⚠ STICKERS: ANCHORAGE POINT)
- Secure the platform with a strap **4** (supplied with the machine); do not overtighten to avoid damage

RESCUE PROCEDURE

⚠ IMPORTANT ⚠

This procedure should be read and fully understood by the operator and any other persons likely to be involved with working on the machine in the event of a breakdown or a person getting trapped in the platform.

SHOULD THE USER FEEL ILL - PRIORITY CONTROLS

Illustrations: #2 = second version, #3 = third version.

If the operator in the platform should fall ill or find himself incapable of maneuvering, the person present on the ground can take over the machine controls from the ground level control panel.

If the diesel engine has been started:

- Push and hold the switch ① to the right 
- Lower the platform using the appropriate control keys
- Release the keys or the switch to stop the current movements

If the diesel engine has not been started and the emergency stop button in the platform is in the ON position (the screen is on):

- Start the diesel engine
- Push and hold the switch ① to the right 
- Lower the platform using the appropriate control keys
- Release the keys or the switch to stop the current movements

If the diesel engine has not been started and the emergency stop button in the platform is in the OFF position (the screen is off):

- Push and hold the switch ① to the right 
- Wait for the preheat cycle to finish and start up the diesel engine
- Lower the platform using the appropriate control keys
- Release the keys or the switch to stop the current movements

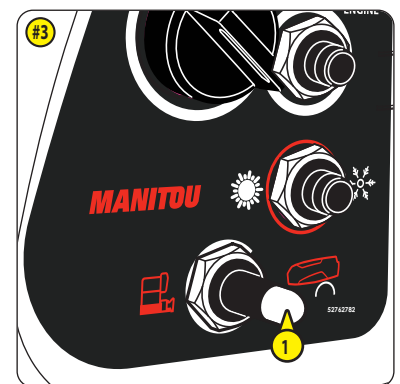
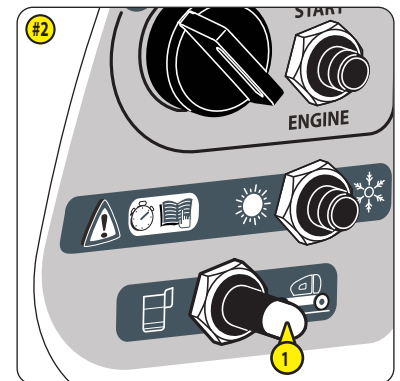

IF THERE IS AN ACCIDENT OR BREAKDOWN - EMERGENCY CONTROLS

⚠ IMPORTANT ⚠

*The tilt alarm and overload alarm may no longer be active when the emergency controls are in use. Activation of functions likely to tip over or imbalance the machine is prohibited.
The backup pump should be activated for a maximum of 4 minutes, then wait 10 minutes before reactivating the pump for a new 4 minute cycle.*

If an accident or breakdown occurs making the ground level and platform control panels unusable, the machine has emergency controls for certain machine functions.

- Open the left-hand turntable cover
- Locate the various components of the emergency controls:
 - Pump lever ①
 - Manual backup pump ②
 - Hydraulic control valve ③ and manual controls ③A to ③E
- Take the pump lever ① and place it in the manual backup pump housing ②
- Use the controls described in the following pages

NOTE: refer to the BACKUP PUMP stickers ⓐ, ⓐ STICKERS.

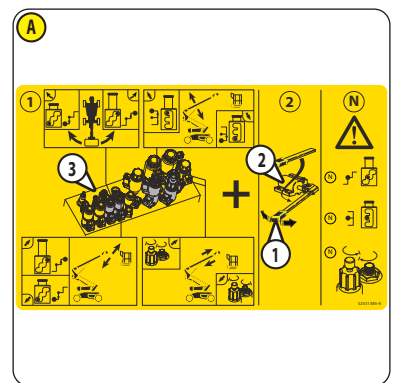
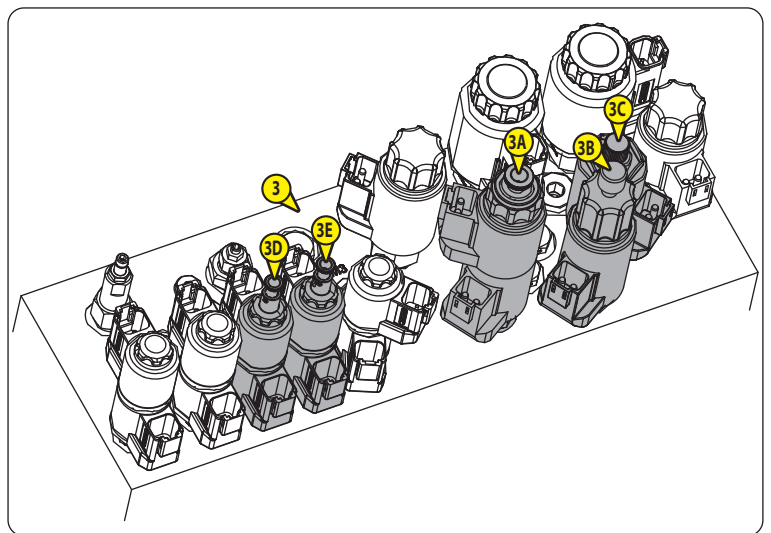
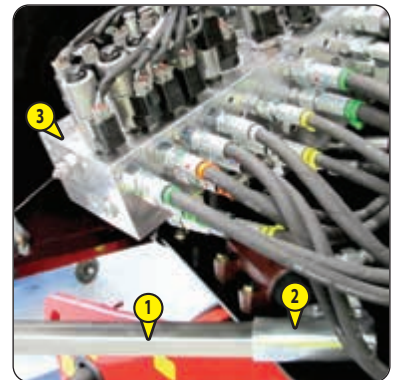
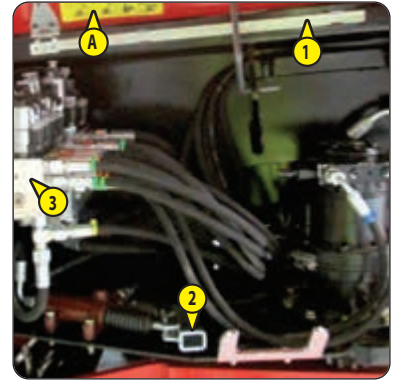

EMERGENCY CONTROLS FROM THE HYDRAULIC CONTROL VALVE 3

A- RAISE THE MAIN/SECONDARY ARM

- 1 - Turn the valve knob 3A counterclockwise, then turn it clockwise until it stops.
- 2 - Pump to raise the main/secondary arm, stop when the desired position is reached.
- 3 - Turn the valve knob 3A counterclockwise, release it and then turn it clockwise until it stops.

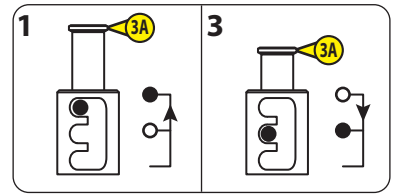

B- LOWER THE MAIN/SECONDARY ARM

- 1 - Turn the valve knob 3A counterclockwise, push it and then turn it clockwise until it stops.
- 2 - Pump to lower the main/secondary arm, stop when the desired position is reached.
- 3 - Turn the valve knob 3A counterclockwise, release it and then turn it clockwise until it stops.

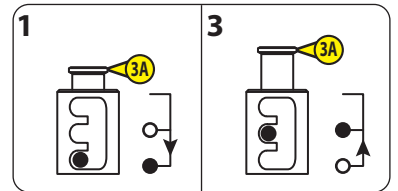

C - EXTEND THE TELESCOPE

- 1 - Turn the valve knob 3B clockwise until it stops. Turn the valve knob 3C clockwise until it stops.
- 2 - Pump to extend the telescope, stop when the desired position is reached.
- 3 - Turn the button of the valve 3B counterclockwise until it stops. Make sure that the valve knob 3C is turned clockwise until it stops.

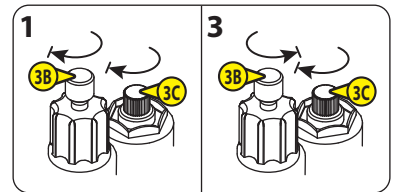

D - RETRACT THE TELESCOPE

- 1 - Turn the valve knob 3B clockwise until it stops. Turn the button of the valve 3C counterclockwise until it stops.
- 2 - Pump to retract the telescope, stop when the desired position is reached.
- 3 - Turn the button of the valve 3B counterclockwise until it stops. Turn the valve knob 3C clockwise until it stops.

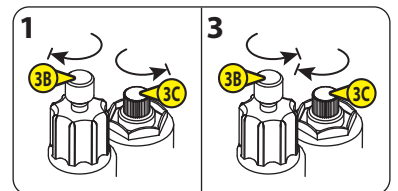

E- TURN THE TURNTABLE TO THE LEFT

- 1 - Push the valve knob 3D, turn it clockwise until it stops and release it.
- 2 - Pump to turn the turntable to the left, stop when the desired position is reached.
- 3 - Turn the valve knob 3D counterclockwise until it stops and release it.

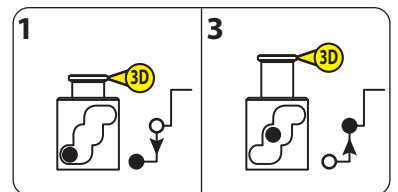

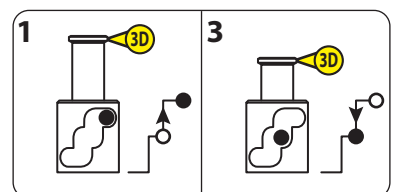

F- TURN THE TURNTABLE TO THE RIGHT

- 1 - Pull the valve knob 3D, turn it counterclockwise until it stops and release it.
- 2 - Pump to turn the turntable to the right, stop when the desired position is reached.
- 3 - Turn the valve knob 3D clockwise until it stops and release it.



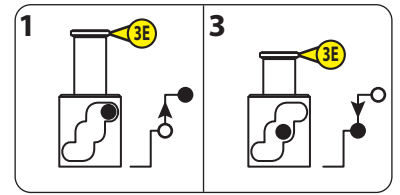

G- RAISE THE JIB

- 1 - Pull the valve button , turn it counterclockwise until it stops and release it.
- 2 - Pump to raise the jib, stop when the desired position is reached.
- 3 - Turn the valve knob  clockwise until it stops and release it.



H- LOWER THE JIB

- 1 - Push the valve knob , turn it clockwise until it stops and release it.
- 2 - Pump to lower the jib, stop when the desired position is reached.
- 3 - Turn the valve knob  counterclockwise until it stops and release it.

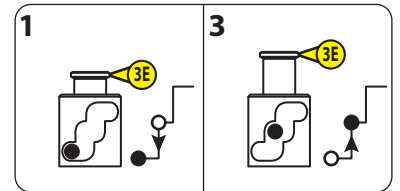

OPTIONS

KEY LOCK FOR TURNTABLE COVERS

⚠ IMPORTANT ⚠

To guarantee access to the emergency controls, it is mandatory to unlock the left-hand turntable cover before using the machine from the platform.

BATTERY CUT-OFF

2 positions:

- Off "OFF": the handle ① is vertical.
- On "ON": the handle ① is horizontal.

Note: ⚡ STICKERS: BATTERY CUT-OFF ③A.



230 V ELECTRIC POWER SOCKET IN THE PLATFORM

This option includes:

- 1 plug ① at the rear of the turntable.
- 1 electric power socket ② in the platform.
- 1 electric unit ③ with 1 30 mA residual-current circuit breaker.

INSTRUCTIONS: ELECTRIC POWER SOCKET IN THE PLATFORM

⚠ IMPORTANT ⚠

Connect the plug to a 230 V/50 Hz power source delivering 16 A.

Only connect electrical appliances that work with 230 V/50 Hz, 16 A maximum.

Do not connect extension cords, power supply bars or plugs with multiple sockets to the electric power socket.

- Connect the plug ① to a power source.
- Plug 1 electrical appliance into the power socket ②.
- Switch on the electrical appliance.
- Power down the electrical appliance when the work has been completed.
- Disconnect the electrical plug.

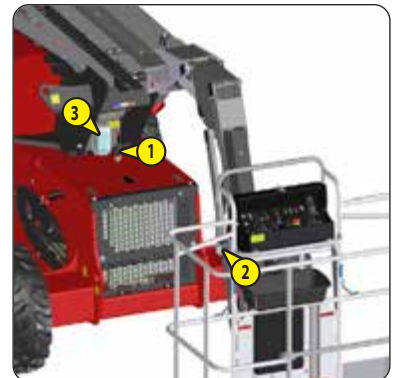

INSTRUCTIONS: RESIDUAL-CURRENT CIRCUIT BREAKER

To reset the residual-current circuit breaker:

- Turn off the power to the electrical appliance.
- Put the machine in transport position, ⚡ OPERATING THE MACHINE: TRANSPORT/WORKING POSITION.
- Fully lower the jib arm.
- Open the electrical box cover panel ③A.
- Push the switch ③B to the ON position.

Result:

- The switch must remain in the ON position, the indicators ③C and ③D should be red.
- Close the electrical box cover panel.



ELECTRIC GENERATOR

The electric generator option includes:

- 1 electric generator **1**, located on the right-hand side of the turntable, with 1 30 mA residual-current circuit breaker.
- 1 electric generator button **2** on the platform control panel.
- 110 V 3.5 kW electric generator option:
 - 1 electric power socket **3** in the platform supplying 110 V/50 Hz, 16 A maximum.
- 230 V 3.5 kW electric generator option:
 - 1 electric power socket **3** in the platform supplying 230 V/50 Hz, 16 A maximum.

Note: STICKERS: 110 V ELECTRICAL SYSTEM (OPTION) or STICKERS: 230 V ELECTRICAL SYSTEM (OPTION).

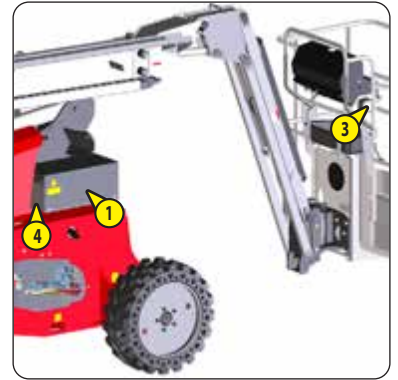

INSTRUCTIONS: ELECTRIC POWER SOCKET IN THE PLATFORM

⚠ IMPORTANT ⚠

Only connect electrical appliances that work with:

- 110 V/50 Hz, 16 A maximum (110 V 3.5 kW electric generator option).
- 230 V/50 Hz, 16 A maximum (230 V 3.5 kW electric generator option).

Do not connect extension cords, power supply bars or plugs with multiple sockets to the electric power socket(s). The electric generator is automatically stopped when any machine function is activated. It automatically restarts when the machine's functions are no longer activated.

Overvoltages could occur when the electric generator is started. Make sure that the electrical equipment is powered down before:

- Starting the electric generator.
- Activating the machine's functions when the electric generator is started.

Note: the diesel engine must be started.

- Press and release the electric generator button **2** to start the electric generator.
- 110 V 3.5 kW electric generator option and 230 V 3.5 kW electric generator option:
 - Plug 1 electrical appliance into the power socket **3**.
- Switch on the electrical appliance.
- Power down the electrical appliance when the work has been completed.
- Press and release the electric generator button to stop the electric generator.

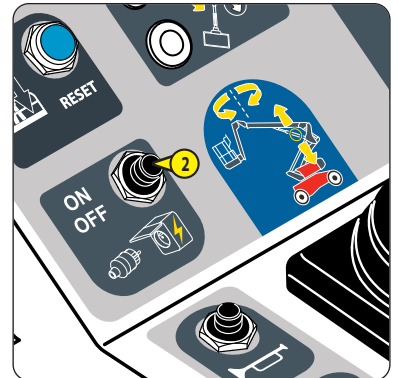

INSTRUCTIONS: RESIDUAL-CURRENT CIRCUIT BREAKER

To reset the residual-current circuit breaker:

- Power down the electrical appliance(s).
- Press and release the electric generator button **2** to stop the electric generator.
- Put the machine in transport position, OPERATING THE MACHINE: TRANSPORT/ WORKING POSITION.
- Fully lower the jib arm.
- Lift up the flap **4**.
- Locate the switch **5A** on the electric generator **1**.
- Push it to the ON position.

Result:

- The switch must remain in the ON position, the indicator **5B** should be red.
- Press and release the electric generator button **2** to start the electric generator.
- Check that the switch **5A** remains in the ON position and that the indicator **5B** is red.

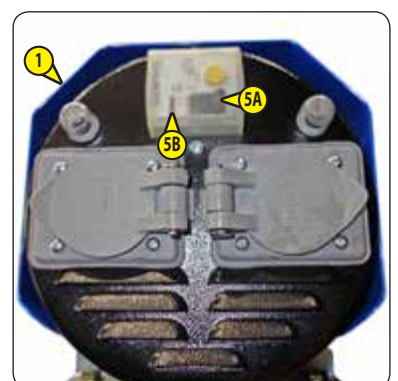

SECONDARY PROTECTION SYSTEM SPS - FIRST VERSION "SAFEMANSYSTEM"

⚠ IMPORTANT ⚠

Operate the controls extremely carefully during attempts at clearance.

If the audible alarm sounds intermittently and rapidly and the flashing light SPS ① flashes rapidly: The machine can be used, but the secondary protection system SPS "SafeManSystem" is deactivated; consult the maintenance personnel.

NOTE: the audible alarm sounds once and the flashing light SPS ① flashes several times when the machine is powered up. This indicates that the secondary protection system SPS "SafeManSystem" is operating correctly.

NOTE: the flashing light SPS ① can be blue or red depending on the country.

OPERATION DESCRIPTION

If you are trapped between the pressure sensitive bar SPS ② and a structure A:

- All of the machine's functions are stopped and locked
- The horn sounds intermittently and the flashing light SPS ① flashes
- AUTOMATIC TELESCOPE RETRACTION option (depending on version):
 - The telescope automatically retracts in less than 4 seconds.
- If you are still trapped between the safety edge SPS and the structure:
 - Press and release the reset button SPS ③.

Result:

- The machine's functions are unlocked, use the controls to get free
- The horn stops sounding and the flashing light SPS stops flashing when you are no longer trapped

- If you are no longer trapped between the pressure sensitive bar SPS and the structure:
 - Press and release the reset button SPS ③.

Result:

- All of the machine's functions are unlocked
- The horn stops sounding and the flashing light SPS stops flashing

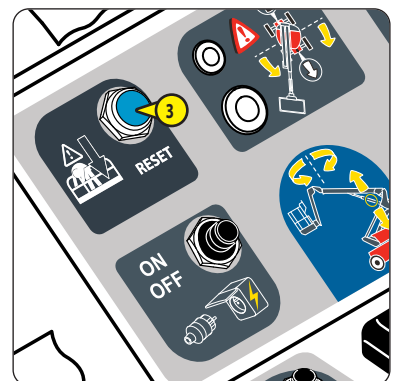
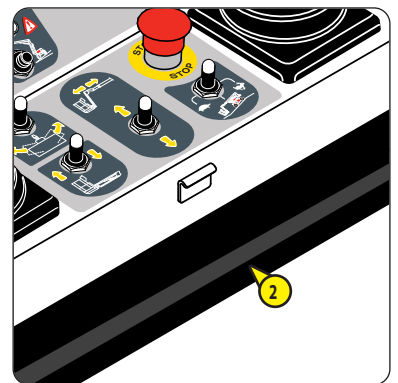

SECONDARY PROTECTION SYSTEM SPS - SECOND VERSION

⚠ IMPORTANT ⚠

Operate the controls extremely carefully during attempts at clearance.

If the audible alarm sounds intermittently and rapidly and the flashing light SPS ① flashes rapidly: The machine can be used, but the secondary protection system SPS is deactivated; consult the maintenance personnel.

NOTE: the audible alarm sounds once and the flashing light SPS ① flashes several times when the machine is powered up. This indicates that the secondary protection system SPS is operating correctly.

NOTE: the flashing light SPS ① can be blue or red depending on the country.

OPERATION DESCRIPTION

If you are trapped between the safety cable SPS ② and a structure A:

- All of the machine's functions are stopped and locked
- The horn sounds intermittently and the flashing light SPS ① flashes
- AUTOMATIC TELESCOPE RETRACTION option (depending on version):
 - The telescope automatically retracts in less than 4 seconds.
- If you are still trapped between the safety cable SPS and the structure:
 - Press and release the reset button SPS ③.

Result:

- The machine's functions are unlocked, use the controls to get free
- The horn stops sounding and the flashing light SPS stops flashing when you are no longer trapped

- If you are no longer trapped between the safety cable SPS and the structure:

- Press and release the reset button SPS ③.

Result:

- All of the machine's functions are unlocked
- The horn stops sounding and the flashing light SPS stops flashing

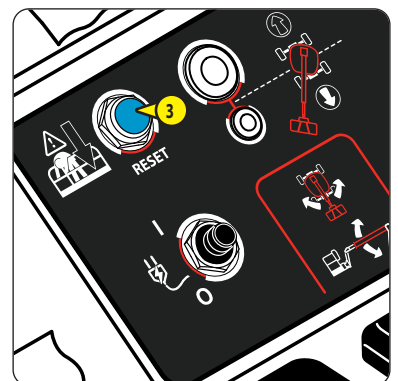
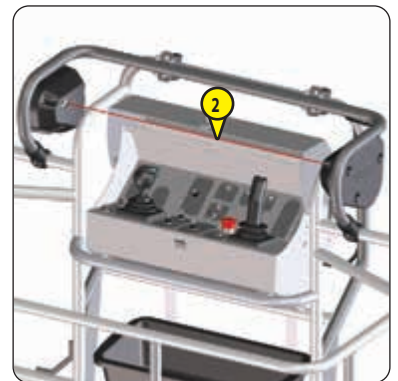

DIESEL ENGINE AUTOMATIC STOP SYSTEM "STOP AND GO"

DIESEL ENGINE AUTOMATIC STOP

The diesel engine is stopped automatically if the following conditions are met:

- The foot switch **1** has been released for at least 30 seconds.
- The activation switch **2** has been released for at least 30 seconds.
- The diesel engine has been started for at least 10 minutes.
- The main arm and/or the secondary arm is not completely lowered.
- The battery voltage is "normal".
- The rear and right chassis covers are closed.
- The machine's last function was activated using the platform control panel.
- The secondary protection system warning SPS (option) is not in progress.
- The electric generator (option) is stopped.

Result:

- The preheat indicator light **3** flashes.
- An alarm page is displayed,  GROUND LEVEL CONTROL PANEL SCREEN: LCD SCREEN PAGES.
- The orange rotating beacon light **4** comes on (cycle: on = 1 second, off = 1 second).

Note: when the permanent orange rotating beacon light is activated, the orange rotating beacon light changes from "continuous operation" status to "cycle: on = 1 second, off = 1 second" status.

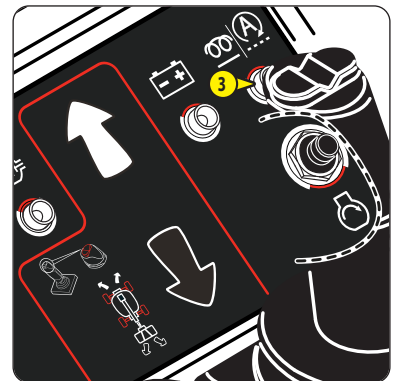
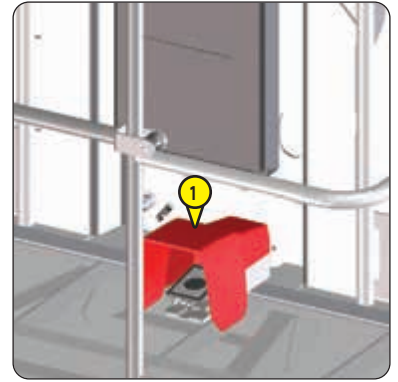

DIESEL ENGINE MANUAL RESTART

⚠ IMPORTANT ⚠

It is recommended to restart the diesel engine when a low battery fault occurs:

- The battery indicator light **5** flashes.
- The audible alarm sounds intermittently.

- An alarm page is displayed,  GROUND LEVEL CONTROL PANEL SCREEN: LCD SCREEN PAGES.

- Press and hold down the foot switch **1**.

or

- Push and hold the activation switch **2** to the right  (ground level controls position).

Note: the rear and right chassis covers are closed.

Note: when preheating is required, the preheat indicator light **3** comes on and the preheat page is displayed,  GROUND LEVEL CONTROL PANEL SCREEN: LCD SCREEN PAGES.

Result:

- The diesel engine starts.
- The preheat indicator light **3** goes out.
- The battery indicator light **5** goes out.
- The audible alarm stops.
- The alarm page is no longer displayed.
- The orange rotating beacon light **4** goes out.

Note: when the permanent orange rotating beacon light is activated, the orange rotating beacon light changes from "cycle: on = 1 second, off = 1 second" status to "continuous operation" status.

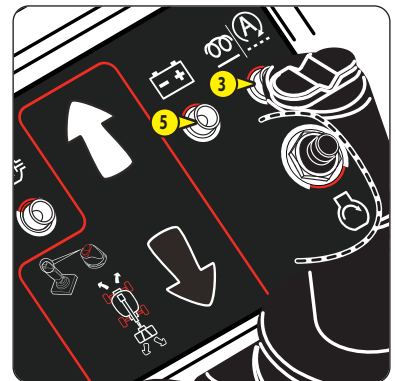
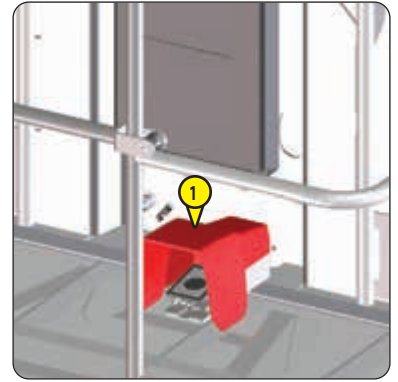

DIESEL ENGINE AUTOMATIC RESTART

The diesel engine is started automatically if the following conditions are met:

- The foot switch **1** is released.
- The activation switch **2** is released.
- The battery voltage is "critical".
- The main/secondary arm is not completely lowered.
- The rear and right chassis covers are closed.

Note: the battery indicator light **5** flashes. The audible alarm sounds intermittently. An alarm page is displayed, GROUND LEVEL CONTROL PANEL SCREEN: LCD SCREEN PAGES.

Note: when preheating is required, the preheat indicator light **3** comes on and the preheat page is displayed, GROUND LEVEL CONTROL PANEL SCREEN: LCD SCREEN PAGES.

Result:

- The diesel engine starts.
- The preheat indicator light **3** goes out.
- The battery indicator light **5** goes out.
- The audible alarm stops.
- The fault page is no longer displayed.
- The orange rotating beacon light **4** goes out.
- The diesel engine automatic stop system "stop and go" is deactivated. It will be automatically reactivated when the machine is turned off and then turned back on with "normal" battery voltage.

Note: when the permanent orange rotating beacon light is activated, the orange rotating beacon light changes from "cycle: on = 1 second, off = 1 second" status to "continuous operation" status.

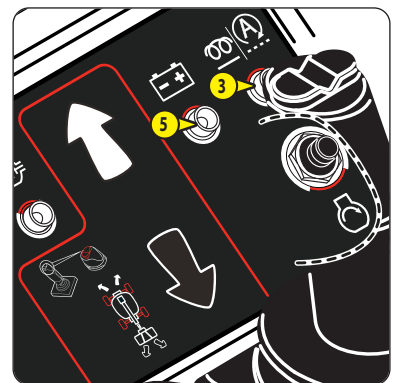
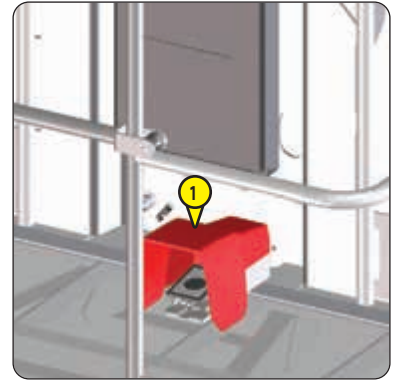

BATTERY HEATER

⚠ IMPORTANT ⚠

*Plug the battery heater to a 230 V/50 Hz power source delivering 16 A protected by a 30 mA residual-current circuit breaker.
The machine should be switched off before connecting the battery heater.*

The battery heater is designed to heat the battery when the outside temperature is below -10 °C.

- Remove the front chassis cover.
- Locate the electrical plug.
- Connect it to a power source.
- Wait for the desired heating time and disconnect it.
- Refit the front chassis cover.

Note: the heating time depends on the ambient temperature and other factors. Adjust the heating time, observing the conditions for starting the diesel engine.

HYDRAULIC OIL HEATER

⚠ IMPORTANT ⚠

*Plug the hydraulic oil heater to a 230 V/50 Hz power source delivering 16 A protected by a 30 mA residual-current circuit breaker.
Before connecting the hydraulic oil heater:*

- *The machine must be in the transport position and the jib arm must be fully lowered, OPERATING THE MACHINE: TRANSPORT/WORKING POSITION.*
- *The hydraulic oil level must be checked, 3 - MAINTENANCE: DAILY MAINTENANCE.*
- *The engine should be stopped.*

The hydraulic oil heater is designed to heat the hydraulic oil when the outside temperature is below -15 °C.

- Remove the front chassis cover.
- Locate the electrical plug.
- Connect it to a power source.
- Wait for the desired heating time and disconnect it.
- Refit the front chassis cover.

Note: the heating time depends on the ambient temperature and other factors. Adjust the heating time, observing the conditions for machine operation.

ENGINE BLOCK HEATER

⚠ IMPORTANT ⚠

*Plug the engine block heater to a 230 V/50 Hz power source delivering 16 A protected by a 30 mA residual-current circuit breaker.
The machine should be switched off before connecting the engine block heater.*

The engine block heater is designed to heat the engine block when the outside temperature is below -10 °C.

- Open the right-hand chassis cover.
- Locate the electrical plug.
- Connect it to a power source.
- Wait for the desired heating time and disconnect it.
- Close the right-hand chassis cover.

Note: the heating time depends on the ambient temperature and other factors. Adjust the heating time, observing the conditions for starting the diesel engine.

WORKLIGHT

The platform on this machine can be equipped with 1 worklight .

TURN ON THE WORKLIGHT

- Use the worklight switch .

TURN OFF THE WORKLIGHT

- Use the worklight switch .



3 - MAINTENANCE

3 - MAINTENANCE

INTRODUCTION	3-3
ORIGINAL MANITOU SPARE PARTS AND EQUIPMENT	3-3
DAILY AND MONTHLY MAINTENANCE	3-4
MANDATORY SERVICING AND PERIODIC MAINTENANCE	3-5
OCCASIONAL MAINTENANCE AND OPERATIONS	3-9
FILTER CARTRIDGES AND BELTS	3-10
LUBRICANTS AND FUEL	3-11
➤ DAILY MAINTENANCE	3-12
➤ MONTHLY MAINTENANCE OR EVERY 50 HOURS OF SERVICE	3-24
➤ ① 250H - PERIODIC MAINTENANCE - EVERY 250 HOURS OF SERVICE OR 6 MONTHS	3-28
➤ ② 500H - PERIODIC MAINTENANCE - EVERY 500 HOURS OF SERVICE OR 1 YEAR	3-35
➤ ③ 1000H - PERIODIC MAINTENANCE - EVERY 1000 HOURS OF SERVICE OR 2 YEARS	3-44
➤ ④ 2000H - PERIODIC MAINTENANCE - EVERY 2000 HOURS OF SERVICE OR 4 YEARS	3-48
➤ OCCASIONAL MAINTENANCE	3-50
➤ OCCASIONAL OPERATIONS	3-54

INTRODUCTION

MAINTENANCE OPERATIONS REQUIRE SPECIFIC PRECAUTIONS.

⚠ IMPORTANT ⚠

In order to maintain the machine's connectivity, some electrical components remain live even when the battery cut-off (option) is in the OFF position.

Unless specific instructions are given, during maintenance operations:

- The machine must be on a level surface. The wheels must be chocked

- The machine should be in TRANSPORT position. The turntable and the platform should be in NEUTRAL position, 2 - DESCRIPTION: OPERATING THE MACHINE: TRANSPORT/WORKING POSITION

- The jib must be fully lowered

- The platform must be empty

- The turntable must be unlocked, 2 - DESCRIPTION: SAFETY COMPONENTS: TURNABLE LOCKING PIN

ORIGINAL MANITOU SPARE PARTS AND EQUIPMENT

OUR MACHINES MUST BE SERVICED USING ORIGINAL MANITOU PARTS.

BY ALLOWING THE USE OF NON ORIGINAL MANITOU PARTS, YOU RISK:

⚠ IMPORTANT ⚠

THE USE OF COUNTERFEIT PARTS OR COMPONENTS NOT APPROVED BY THE MANUFACTURER MEANS YOU LOSE THE BENEFIT OF THE CONTRACTUAL GUARANTEE.

- Legally, incurring liability in the event of an accident
- Technically, causing operating malfunctions and reducing the machine's service life

BY USING ORIGINAL MANITOU PARTS FOR MAINTENANCE OPERATIONS, YOU BENEFIT FROM OUR KNOW-HOW

Through its network, MANITOU provides the user with:

- Know-how and competence
- The guarantee of high-quality work
- Original replacement parts
- Help with preventive maintenance
- Efficient help with diagnosis
- Improvements as a result of feedback
- Operator training
- Only the MANITOU network has detailed knowledge of the design of the machine and therefore the best technical ability to provide maintenance

⚠ IMPORTANT ⚠

ORIGINAL REPLACEMENT PARTS ARE DISTRIBUTED EXCLUSIVELY BY MANITOU AND ITS DEALER NETWORK.

The dealer network list is available on the MANITOU web site: www.manitou.com

DAILY AND MONTHLY MAINTENANCE

⚠ IMPORTANT ⚠

**DAILY MAINTENANCE MUST BE CARRIED OUT BY THE OPERATOR BEFORE USING THE MACHINE.
MONTHLY MAINTENANCE MUST BE CARRIED OUT BY THE MAINTENANCE PERSONNEL.**

➡ DAILY MAINTENANCE

- CHECK	General inspection	3-12
- CHECK	Fuel level	3-12
- CHECK	Battery voltage	3-12
- CHECK	Diesel engine oil level	3-13
- CHECK	Coolant level	3-13
- CHECK	Alternator/fan belt	3-13
- CHECK	Hydraulic oil level	3-14
- CHECK	Machine operation	3-15
- CHECK	Secondary protection system SPS (OPTION)	3-22

➡ MONTHLY MAINTENANCE OR EVERY 50 HOURS OF SERVICE

ALSO PERFORM THE DAILY MAINTENANCE.

- CHECK	Injection pipes, fuel hoses and the hose clamps	3-24
- CHECK	Wheel nut tightening	3-24
- CHECK	230 V electric power socket in the platform (OPTION)	3-24
- CHECK	Electric generator (OPTION)	3-25
- CLEAN	Exterior air filter cartridge	3-26
- CLEAN	Coolant and oil radiators	3-27
- LUBRICATE	Steering pivots	3-27
- RESET	Maintenance warning	3-27

MANDATORY SERVICING AND PERIODIC MAINTENANCE

⚠ IMPORTANT ⚠

THE MANDATORY SERVICE AND THE PERIODIC MAINTENANCE MUST BE CARRIED OUT BY AN APPROVED PROFESSIONAL FROM THE MANITOU NETWORK.

MAINTENANCE SCHEDULE

This schedule enables mandatory servicing and periodic maintenance on the machine to be kept up-to-date by reporting the total number of hours worked and the date of the service.

	⬇	⬇	OR	⬇
SCHEDULE ➡	FIRST 50 HOURS	FIRST 6 MONTHS		FIRST 500 HOURS
MANDATORY SERVICE ➡	FIRST 50 HOURS	FIRST 500 HOURS OR 6 MONTHS		FIRST 500 HOURS OR 6 MONTHS + 2
MACHINE COUNTER ➡				
DATE OF SERVICING ➡				

SCHEDULE ➡	250 H	500 H or 1 YEAR	750 H	1000 H or 2 YEARS	1250 H
PERIODIC MAINTENANCE ➡	1	1 + 2	1	1 + 2 + 3	1
MACHINE COUNTER ➡					
DATE OF SERVICING ➡					

SCHEDULE ➡	1500 H or 3 YEARS	1750 H	2000 H or 4 YEARS	2250 H	2500 H or 5 YEARS
PERIODIC MAINTENANCE ➡	1 + 2	1	1 + 2 + 3 + 4	1	1 + 2
MACHINE COUNTER ➡					
DATE OF SERVICING ➡					

SCHEDULE ➡	2750 H	3000 H or 6 YEARS	3250 H	3500 H or 7 YEARS	3750 H
PERIODIC MAINTENANCE ➡	1	1 + 2 + 3	1	1 + 2	1
MACHINE COUNTER ➡					
DATE OF SERVICING ➡					

SCHEDULE ➡	4000 H or 8 YEARS	4250 H	4500 H or 9 YEARS	4750 H	5000 H or 10 YEARS
PERIODIC MAINTENANCE ➡	1 + 2 + 3 + 4	1	1 + 2	1	1 + 2 + 3
MACHINE COUNTER ➡					
DATE OF SERVICING ➡					

SCHEDULE ➡	5250 H	5500 H or 11 YEARS	5750 H	6000 H or 12 YEARS
PERIODIC MAINTENANCE ➡	1	1 + 2	1	1 + 2 + 3 + 4
MACHINE COUNTER ➡				
DATE OF SERVICING ➡				

ALSO PERFORM THE MONTHLY MAINTENANCE.



This service must be carried out in the first 50 hours of service.

- CHECK	Wheel nut tightening	3-24
- CHECK	Wheel motor seal	3-29
- CHECK	Tightening of wheel motor fixing screws	3-29
- CHECK	Tightening of the screws that fix the steering cylinder to the chassis	3-29
- CHECK	Tightening of the platform fixing screws	3-35
- REPLACE	Diesel engine oil	3-40
- REPLACE	Diesel engine oil filter cartridge	3-40

MANDATORY SERVICE - FIRST 500 HOURS OR 6 MONTHS

This service must be carried out in the first 500 hours of service or within the 6 months following the start-up of the machine (whichever occurs first):

FIRST 500 HOURS BEFORE THE FIRST 6 MONTHS

- If the machine has reached the first 500 hours of service before the first 6 months have expired, perform both the compulsory service and periodic 500-hour maintenance (  500H - PERIODIC MAINTENANCE - EVERY 500 HOURS OF SERVICE OR 1 YEAR).

FIRST 6 MONTHS BEFORE THE FIRST 500 HOURS

- If the machine has not completed 500 hours of service in the first 6 months, carry out only the mandatory service.

- CHECK	General inspection	3-12
- CHECK	Alternator/fan belt	3-13
- CHECK	Machine operation	3-15
- CHECK	Secondary protection system SPS (OPTION)	3-22
- CHECK	Injection pipes, fuel hoses and the hose clamps	3-24
- CHECK	Wheel nut tightening	3-24
- CHECK	230 V electric power socket in the platform (OPTION)	3-24
- CHECK	Electric generator (OPTION)	3-25
- CLEAN	Exterior air filter cartridge	3-26
- CLEAN	Coolant and oil radiators	3-27
- LUBRICATE	Steering pivots	3-27
- CHECK	Alternator/fan belt	3-28
- CHECK	Wheel motor seal	3-29
- CHECK	Tightening of wheel motor fixing screws	3-29
- CHECK	Tightening of the screws that fix the steering cylinder to the chassis	3-29
- CHECK	Overload alarm	3-29
- CHECK	Braking	3-30
- CHECK	Turntable rotation motor oil level	3-31
- CHECK	Emergency controls	3-31
- CLEAN	Fuel filter cartridge	3-32
- LUBRICATE	Shafts, hubs and cylinder rings	3-33
- LUBRICATE	Telescope	3-34
- LUBRICATE	Crown gear	3-34
- CHECK	Tilt sensor (from machine MAN00000K01079391)	3-35
- CHECK	Tightening of the platform fixing screws	3-35
- CHECK	Telescope setting	3-36
- CHECK	Tightening of the fixing screws for the crown gear	3-37
- CHECK	Tightening of the fixing screws on the turntable rotation motor	3-37
- CHECK	Counterweight fixing screw tightening	3-38
- CHECK	Hydraulic hoses	3-38
- CHECK	Diesel engine silent blocks *	3-47
- CHECK	Diesel engine speeds *	3-47
- CHECK	Valve lash *	3-47
- CHECK	Injection pump *	3-47
- CHECK	Fuel injectors *	3-47
- CHECK	Hydrostatic transmission circuit pressure *	3-47
- CHECK	Clearance of slewing ring gear *	3-47
- CHECK	Speeds of hydraulic movements *	3-47
- CHECK	Condition of cylinders *	3-47
- CHECK	Condition of electric wiring *	3-47

*** Consult your dealer.**

➔ ① 250H - PERIODIC MAINTENANCE - EVERY 250 HOURS OF SERVICE OR 6 MONTHS

ALSO PERFORM THE DAILY MAINTENANCE.

- CHECK	Injection pipes, fuel hoses and the hose clamps	3-28
- CHECK	Wheel nut tightening	3-28
- CHECK	230 V electric power socket in the platform (OPTION)	3-28
- CHECK	Electric generator (OPTION)	3-28
- CHECK	Alternator/fan belt	3-28
- CHECK	Wheel motor seal	3-29
- CHECK	Tightening of wheel motor fixing screws	3-29
- CHECK	Tightening of the screws that fix the steering cylinder to the chassis	3-29
- CHECK	Overload alarm	3-29
- CHECK	Braking	3-30
- CHECK	Turntable rotation motor oil level	3-31
- CHECK	Emergency controls	3-31
- CLEAN	Fuel filter cartridge	3-32
- LUBRICATE	Shafts, hubs and cylinder rings	3-33
- LUBRICATE	Telescope	3-34
- LUBRICATE	Crown gear	3-34
- RESET	Maintenance warning	3-34

➔ ② 500H - PERIODIC MAINTENANCE - EVERY 500 HOURS OF SERVICE OR 1 YEAR

ALSO PERFORM THE DAILY SERVICE AND THE PERIODIC SERVICE AT 250 HOURS OF SERVICE.

- CHECK	Tilt sensor (from machine MAN00000K01079391)	3-35
- CHECK	Tightening of the platform fixing screws	3-35
- CHECK	Telescope setting	3-36
- CHECK	Tightening of the fixing screws for the crown gear	3-37
- CHECK	Tightening of the fixing screws on the turntable rotation motor	3-37
- CHECK	Counterweight fixing screw tightening	3-38
- CHECK	Hydraulic hoses	3-38
- REPLACE	Alternator/fan belt	3-38
- REPLACE	Fuel filter cartridge (pre-filter)	3-39
- REPLACE	Fuel filter cartridge	3-39
- REPLACE	Diesel engine oil	3-40
- REPLACE	Diesel engine oil filter cartridge	3-40
- REPLACE	Exterior air filter cartridge	3-41
- REPLACE	Turntable rotation motor oil	3-42
- REPLACE	Hydraulic pressure filter cartridge	3-42
- REPLACE	Hydrostatic transmission filter cartridge	3-43
- RESET	Maintenance warning	3-43

➔ ③ 1000H - PERIODIC MAINTENANCE - EVERY 1000 HOURS OF SERVICE OR 2 YEARS

ALSO PERFORM THE DAILY SERVICE AND THE PERIODIC SERVICES AT 250 HOURS AND 500 HOURS OF SERVICE.

- CLEAN	Fuel tank	3-44
- REPLACE	Interior air filter cartridge	3-44
- REPLACE	Coolant	3-45
- REPLACE	Hydraulic oil	3-46
- CLEAN	Filling filter and suction strainers	3-46
- CHECK	Diesel engine silent blocks *	3-47
- CHECK	Diesel engine speeds *	3-47
- CHECK	Valve lash *	3-47
- CHECK	Injection pump *	3-47
- CHECK	Fuel injectors *	3-47
- CHECK	Hydrostatic transmission circuit pressure *	3-47
- CHECK	Clearance of slewing ring gear *	3-47
- CHECK	Speeds of hydraulic movements *	3-47
- CHECK	Condition of cylinders *	3-47
- CHECK	Condition of electric wiring *	3-47
- RESET	Maintenance warning	3-47

* Consult your dealer.

➔ 4 2000H - PERIODIC MAINTENANCE - EVERY 2000 HOURS OF SERVICE OR 4 YEARS

ALSO PERFORM THE DAILY SERVICE AND THE PERIODIC SERVICES AT 250 HOURS, 500 HOURS AND 1000 HOURS OF SERVICE.

- CHECK	Coolant and oil radiators *	3-48
- CHECK	Water pump and thermostat *	3-48
- CHECK	Alternator and starter *	3-48
- CHECK	Hydraulic circuit pressures *	3-48
- CHECK	Hydraulic circuit flow rates *	3-48
- CLEAN	Hydraulic oil tank *	3-48
- REPLACE	Air intake line and air suction hose *	3-48
- REPLACE	Coolant radiator pipes and cable ties *	3-48
- REPLACE	Rubber water pipes *	3-48
- REPLACE	Injection pipes, fuel hoses and the hose clamps *	3-48
- RESET	Maintenance warning	3-48

*** Consult your dealer.**

OCCASIONAL MAINTENANCE AND OPERATIONS

⚠ IMPORTANT ⚠

OCCASIONAL MAINTENANCE AND OCCASIONAL OPERATIONS MUST BE PERFORMED BY MAINTENANCE PERSONNEL OR AN APPROVED PROFESSIONAL FROM THE MANITOU NETWORK.

➔ OCCASIONAL MAINTENANCE

- REPLACE	Wheels	3-50
- REPLACE	Fuses/relays	3-50
- BLEED	Fuel supply circuit	3-52

➔ OCCASIONAL OPERATIONS

- WINCH	Machine	3-54
- LIFT	Machine	3-55

FILTER CARTRIDGES AND BELTS

➔ 2 500H - PERIODIC MAINTENANCE - EVERY 500 HOURS OF SERVICE OR 1 YEAR



DIESEL ENGINE OIL FILTER CARTRIDGE

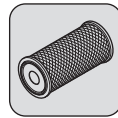

EXTERIOR AIR FILTER CARTRIDGE



ALTERNATOR/FAN BELT

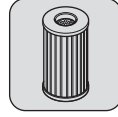

FUEL FILTER CARTRIDGE

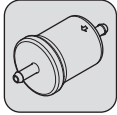

FUEL FILTER CARTRIDGE (PRE-FILTER)

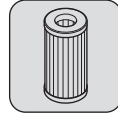

HYDRAULIC PRESSURE FILTER CARTRIDGE

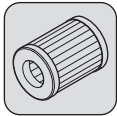

HYDROSTATIC TRANSMISSION FILTER CARTRIDGE

➔ 3 1000H - PERIODIC MAINTENANCE - EVERY 1000 HOURS OF SERVICE OR 2 YEARS

ALSO ADD FILTER CARTRIDGES AND BELTS FOR PERIODIC MAINTENANCE AFTER 500 HOURS OF SERVICE.

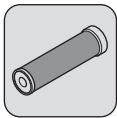

INTERIOR AIR FILTER CARTRIDGE

➔ AS REQUIRED

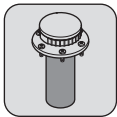

HYDRAULIC OIL TANK CAP/FILTER

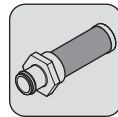

HYDRAULIC OIL TANK SUCTION STRAINER

LUBRICANTS AND FUEL

⚠ IMPORTANT ⚠

USE THE RECOMMENDED LUBRICANTS AND FUEL:

- For topping up, oils may not be miscible.
- For oil changes, MANITOU oils are perfectly appropriate.

DIAGNOSTIC ANALYSIS OF OILS

If a service or maintenance contract has been set up with the dealer, a diagnostic analysis of diesel engine, transmission and axle oils may be requested depending on the rate of use.

(*) REQUIRED FUEL SPECIFICATION

Use a high-quality fuel to obtain optimal performance of the diesel engine.

- ASTM D975 diesel fuel (sulfur content < 15 ppm)

RECOMMENDATION

DIESEL ENGINE		
DESCRIPTION	CAPACITY	RECOMMENDATION
		-40 °C -30 °C -20 °C -10 °C 0 °C 10 °C 20 °C 30 °C 40 °C 50 °C
DIESEL ENGINE OIL	5,1 L	10W30
		10W40
		MANITOU OIL 15W40 API CH4
COOLING CIRCUIT	4 L	COOLANT -35°C
FUEL TANK	53 L	DIESEL FUEL *

HYDRAULICS		
DESCRIPTION	CAPACITY	RECOMMENDATION
		-40 °C -30 °C -20 °C -10 °C 0 °C 10 °C 20 °C 30 °C 40 °C 50 °C
HYDRAULIC OIL TANK	60 L	ISO VG 100
		ISO VG 68
		MANITOU HYDRAULIC OIL ISO VG 46
		ISO VG 37
		ISO VG 32

TRANSMISSION		
DESCRIPTION	CAPACITY	RECOMMENDATION
		-40 °C -30 °C -20 °C -10 °C 0 °C 10 °C 20 °C 30 °C 40 °C 50 °C
STEERING PIVOT PINS		MANITOU BLACK MULTI-PURPOSE LUBRICANT

LIFTING STRUCTURE		
DESCRIPTION	CAPACITY	RECOMMENDATION
		-40 °C -30 °C -20 °C -10 °C 0 °C 10 °C 20 °C 30 °C 40 °C 50 °C
GENERAL GREASING		MANITOU BLACK MULTI-PURPOSE LUBRICANT
TELESCOPE LUBRICATION		MANITOU BLACK MULTI-PURPOSE LUBRICANT
CROWN GEAR BEARINGS		MANITOU BLACK MULTI-PURPOSE LUBRICANT
CROWN GEAR TEETH		MANITOU MULTI-PURPOSE EXTREME PRESSURE LUBRICANT
TURNTABLE ROTATION MOTOR	3 L	MANITOU MECHANICAL TRANSMISSION OIL SAE80W90

⚠ IMPORTANT ⚠

Consult the maintenance personnel if there is doubt about the condition of the machine.

NOTE: to carry out the general inspection of the machine, the turntable covers must be opened; the right chassis cover must be open; the front and rear chassis covers must be removed. They must be closed/put back in place once the general inspection has finished.

The operator must perform a visual and physical inspection of the machine:

- Check that the instructions for use are clean and complete
- Check the stickers and make sure they are all present, clean and legible, ☞ 2 - DESCRIPTION: STICKERS
- Check for the absence of leaks: fuel, diesel engine oil, coolant, battery fluid, hydraulic oil, lubricants, etc.
- Check the condition of the structure: absence of impacts, damage, cracked welding, corrosion, excessive mechanical play, wear, etc.
- Check the condition of the platform: structure, floor, sliding mid rails, gate, harness attachment points, etc.
- Check the condition of the hydraulic components: pumps, control valves, valves, diesel engines, cylinders, hoses, etc.
- Check the condition of the mechanical components: wheels, tires, tie rods, crown gear, shafts, etc.
- Check the condition of the electrical components: control panels, foot switch, control handles, switches, buttons, indicator lights, battery, fuses, cables, harnesses, rotating beacon light, etc.
- Check the condition of covers, handles, locks, plugs, etc.
- Check there are no parts missing or loose: screws, nuts, pins, etc.
- Check that no parts are missing or have had unauthorized modifications
- Check the general cleanliness of the machine: platform floor, diesel engine compartments, etc.

CHECK

Fuel level

CHECK

Battery voltage

⚠ IMPORTANT ⚠

Never smoke or approach with a flame when filling with fuel or when the tank cap has been removed.

Never fill up with fuel while the diesel engine is running.

If there is doubt about the battery voltage, refer to the maintenance personnel.

- Switch the machine on
- Check the fuel level displayed on the ground level control panel screen
- If the level is low:
 - Open the right-hand turntable cover
 - Remove the cap from the tank ☞ 2
 - Add fuel until the maximum level ☞ A is reached, ☞ LUBRICANTS AND FUEL
 - Refit the tank cap
- If the level is correct:
 - Ensure that the tank cap ☞ 2 is correctly closed
- Check the battery voltage displayed on the ground level control panel screen; refer to maintenance personnel if the charge level is low
- Switch the machine off
- Close the right-hand turntable cover



CHECK

Diesel engine oil level

- Remove the rear chassis cover
- Remove the dipstick **1**, clean it with a clean cloth and reinsert
- Remove the dipstick; the level is correct when the diesel engine oil is between the 2 marks **A** and **B**
- If the level is low:
 - Put the dipstick back in place
 - Remove the filler plug **2**
 - Add diesel engine oil, \triangleleft LUBRICANTS AND FUEL
 - Refit the filler cap
 - Wait 5 minutes for the oil to settle in the diesel engine crankcase
 - Remove the dipstick, clean it with a clean cloth and reinsert
 - Remove the dipstick; the level is correct when the diesel engine oil is between the 2 marks **A** and **B**
 - Put the dipstick back in place
- If the level is correct:
 - Put the dipstick back in place
 - Ensure that the filler cap **2** is correctly closed

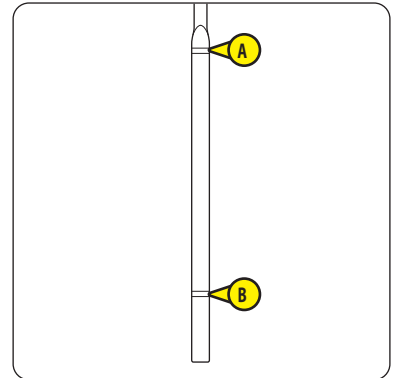
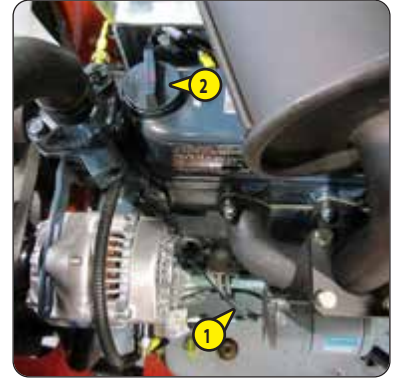

CHECK

Coolant level

⚠ IMPORTANT ⚠

*Wait until the diesel engine cools if it has been running for a while.
Do not remove the radiator cap until the diesel engine is completely cooled.*

REMINDER: the rear chassis cover has been removed.

- Remove the radiator cap **1**; the level is correct when the coolant reaches the top of the filling hole
- If the level is low, add coolant until the correct level is reached, \triangleleft LUBRICANTS AND FUEL
- Refit the radiator cap

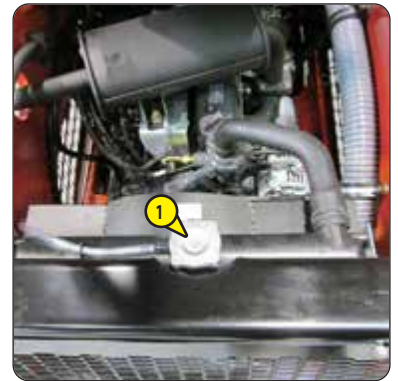

CHECK

Alternator/fan belt

⚠ IMPORTANT ⚠

If there is doubt about the condition of the belt, refer to the maintenance personnel.

REMINDER: the rear chassis cover has been removed.

- Check the condition of the belt **1**; ensure there are no cracks or signs of wear
- Check the belt tension between the crankshaft pulley and the alternator pulley:
 - Apply pressure with the thumb = 98 N. The clearance **A** must be between 7 mm and 9 mm to be correct
- Adjust if necessary:
 - Refer to the maintenance personnel
- Refit the rear chassis cover

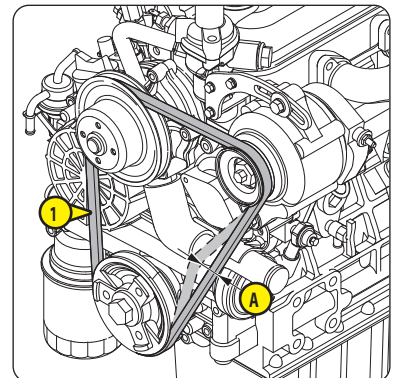

⚠ IMPORTANT ⚠

*The machine must be in TRANSPORT position with the jib lowered completely.
There can be a difference in level of 10 mm to 20 mm between hot and cold oil. It is recommended the level is checked again when the hydraulic oil is hot.
Clean the oil can before adding oil to the hydraulic oil tank.
Use a clean funnel to add oil to the hydraulic oil tank.*

- Locate the level indicator **1**; the level is correct when the oil reaches the red dot on the level indicator
- If the level is low:
 - Start the diesel engine
 - Turn the turntable to 90°
 - Switch the machine off
 - Remove the front chassis cover
 - Remove the cap from the tank **2**
 - Add hydraulic oil until the correct level is reached,  LUBRICANTS AND FUEL
 - Refit the tank cap
 - Refit the front chassis cover
 - Start the diesel engine
 - Put the turntable in NEUTRAL position
 - Switch the machine off
- If the level is correct:
 - Remove the front chassis cover
 - Ensure that the tank cap **2** is correctly closed
 - Refit the front chassis cover

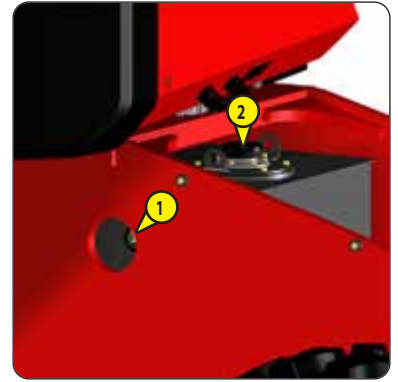

⚠ IMPORTANT ⚠

- ◀ 2 - DESCRIPTION for more information on the control panels on the ground and in the platform.
 Select a test area on a firm, level surface that is free of any obstacles.
 Look around and above you when maneuvering the machine (lifting, rotation, etc.).
 Pay particular attention to electric lines and any object that may be within the machine's working area.
 Identify and shut the machine down if a malfunction is detected.

GROUND LEVEL CONTROL PANEL

Note:

- Permanent orange rotating beacon light activated: the orange rotating beacon light must come on when the machine is powered up.
- Permanent orange rotating beacon light deactivated: the orange rotating beacon light must come on when the machine's functions are activated.
- All movements alarm option activated: the horn sounds intermittently when the machine functions are activated.

POWERING ON AND STARTING THE DIESEL ENGINE AND EMERGENCY STOP

Note: the battery cut-off (option) is in the OFF position. The ignition key is in the OFF position.

Note: the machine is in transport position. The turntable and the platform are in neutral position. The jib arm is completely lowered.

- Ensure that the emergency stop buttons on the ground level and platform control panels are in the ON position.
- Battery cut-off option: turn the battery cut-off to the ON position.
- Turn the ignition switch to the ON position.

Result:

- The screen should light up and display the machine's power-on cycle
- The audible alarm should sound once.
- Secondary protection system option SPS: the flashing light SPS must flash several times and then go out.
- If the outside temperature is above -10 °C:
 - Wait for the preheat cycle to finish.
 - Press and hold down the start button.

Result:

- The diesel engine should start.
- Release the start button.
- If the outside temperature is below -10 °C:
 - Wait for the preheat cycle to finish.
 - Press and release the start mode button.
 - Press and hold down the start button.

Result:

- The diesel engine should start and run at high speed.
- Release the start button.
- Wait for between 30 and 60 seconds without using the machine's functions.
- Raise the main arm for 3 seconds.

Result:

- The diesel engine must idle.
- Fully lower the main arm.
- Press the emergency stop button

Result:

- The emergency stop button should be pushed down (OFF position)
- The diesel engine should stop and the screen should go dark
- Pull the emergency stop button or turn it clockwise and release it (ON position)

Result:

- The emergency stop button should be pulled (ON position)
- The screen should light up and display the machine's power-on cycle
- The audible alarm should sound once.
- Secondary protection system option SPS: the flashing light SPS must flash several times and then go out.
- Wait until the preheat cycle has finished and start the diesel engine.

MACHINE FUNCTIONS

⚠ IMPORTANT ⚠

During this test, turn the turntable by a small angle to avoid injury.

REMINDER: the diesel engine is started; the machine is in the TRANSPORT position; the turntable and the platform are in the NEUTRAL position; the jib is completely lowered.

NOTE: do not drive or steer the machine during this test.

- Do not touch the ground/platform controls selector switch; try to activate the machine functions one by one

Result:

- It should not be possible to activate any of the machine's functions
- Push and hold the ground level/platform controls selector switch to the right.
- Activate all the machine's functions one by one. Check that all the movements are complete up to the mechanical stops.

Result:

- It should be possible to activate all the functions.
- All the movements must operate correctly and smoothly.
- All the movements must be complete up to the mechanical stops.
- Place the machine in transport position. Put the turntable in neutral position. Level the platform/jib. Fully lower the jib arm.
- Release the ground level/platform controls selector switch.

TILT ALARM up to machine MAN 00000P01079390

The engine has been started. The machine is in transport position. The turntable and the platform are in the neutral position. The jib arm is completely lowered.

- Open the right-hand turntable cover. Locate the tilt sensor.
- Press and hold the tilt sensor.

Result:

- The audible alarm should sound intermittently.
- The tilt sensor indicator lamp should go out.
- The LCD screen should display a tilt alarm page.
- Release the tilt sensor.

Result:

- The audible alarm should stop.
- The tilt sensor indicator lamp should light up.
- The LCD screen should no longer display the tilt alarm page.

OVERLOAD ALARM

REMINDER: the diesel engine is started; the machine is in the TRANSPORT position; the turntable and the platform are in the NEUTRAL position; the jib is completely lowered.

- Place a uniformly distributed 253 kg weight in the platform:

Result:

- The audible alarm should sound continuously
- The overload alert should be displayed on the screen
- Try to activate the machine's functions one by one

Result:

- It should not be possible to activate any of the functions
- Remove 23 kg so you have a 230 kg weight in the platform:

Result:

- The audible alarm should stop
- The overload warning should no longer be displayed on the screen
- Activate the machine's functions one by one

Result:

- It should be possible to activate all the functions

PLATFORM CONTROL PANEL

Note:

- Permanent orange rotating beacon light activated: the orange rotating beacon light must come on when the machine is powered up.
- Permanent orange rotating beacon light option deactivated: the orange rotating beacon light must come on when the machine functions are activated and when driving/steering the machine.
- All movements alarm option activated: the horn must sound intermittently when the machine functions are activated and when driving/steering the machine.
- Driving/steering alarm option activated: the horn should sound intermittently when driving/steering the machine.

OVERLOAD ALARM

REMINDER: the diesel engine is started; the machine is in the TRANSPORT position; the turntable and the platform are in the NEUTRAL position; the jib is completely lowered.

REMINDER: there is a 230 kg weight in the platform:

- Get into the platform

Result:

- The audible alarm should sound continuously
- The overload warning indicator lamp should flash

- Try to activate the machine's functions one by one

Result:

- It should not be possible to activate any of the functions

- Get out of the platform

Result:

- The audible alarm should stop
- The overload warning indicator lamp should go out

- Remove the whole weight from the platform

STARTING THE DIESEL ENGINE AND EMERGENCY STOP

REMINDER: the diesel engine is started; the machine is in the TRANSPORT position; the turntable and the platform are in the NEUTRAL position; the jib is completely lowered.

- Press the emergency stop button

Result:

- The emergency stop button should be pushed down (OFF position)
- The diesel engine should stop

- Pull the emergency stop button or turn it clockwise and release it (ON position)

Result:

- The emergency stop button should be in the ON position.
- The preheat light should light up
- The audible alarm should sound once.
- Secondary protection system option SPS: the flashing light SPS must flash several times and then go out.

- Wait for the preheat indicator lamp to go out

- Press the diesel engine start button

Result:

- The diesel engine should start

- Raise the jib, at the same time pressing the emergency stop button

- Result:

- The emergency stop button should be pressed down (OFF position)
- The jib should stop moving
- The diesel engine should stop

- Pull the emergency stop button or turn it clockwise and release it (ON position)

Result:

- The emergency stop button should be pulled (ON position)

- Wait until the preheat light goes out and start the diesel engine.

- Fully lower the jib

HORN

REMINDER: the diesel engine is started; the machine is in the TRANSPORT position; the turntable and the platform are in the NEUTRAL position; the jib is completely lowered.

- Press the horn button and release it

Result:

- The horn should sound

PLATFORM/JIB TILT



During this test, tilt the platform/jib arm up and down slightly to avoid injury.

REMINDER: the diesel engine is started; the machine is in the TRANSPORT position; the turntable and the platform are in the NEUTRAL position; the jib is completely lowered.

NOTE: do not drive or steer the machine during this test.

- Do not touch the foot switch. Try to tilt the platform/jib arm up and down.

Result:

- It should not be possible to activate any of the functions.
- Press and hold down the foot switch.
- Raise the jib slightly
- Tilt the platform/jib up and down slightly to avoid injury.

Result:

- It should be possible to activate the functions.
- Extend the telescope for 3 seconds

Result:

- It should be possible to activate the function.
- Try to tilt the platform/jib up and down.

Result:

- It should not be possible to activate the functions.
- Fully retract the telescope. Level the platform/jib. Fully lower the jib arm.
- Release the foot switch.

MACHINE FUNCTIONS (apart from platform/jib tilt)

REMINDER: the diesel engine is started; the machine is in the TRANSPORT position; the turntable and the platform are in the NEUTRAL position; the jib is completely lowered.

NOTE: do not drive or steer the machine during this test.

- Do not touch the foot switch. Try to activate the machine's functions one by one

Result:

- It should not be possible to activate any of the functions
- Press and hold down the foot switch
- Activate the machine's functions one by one; check that the movements are complete and stop at the mechanical stops

Result:

- It should be possible to activate the functions.
- All the movements must operate correctly and smoothly.
- All the movements must be complete up to the mechanical stops
- Place the machine in TRANSPORT position
- Put the turntable and platform in NEUTRAL position
- Fully lower the jib
- Release the foot switch.

DRIVING/STEERING/BRAKING FUNCTIONS AND DRIVING SPEED SELECTION

REMINDER: the diesel engine is started; the machine is in the TRANSPORT position; the turntable and the platform are in the NEUTRAL position; the jib is completely lowered.

- Do not touch the foot switch; do not touch the driving/steering control handle trigger; try to drive and steer the machine
- Do not touch the foot switch; press and hold down the driving/steering control handle trigger; try to drive and steer the machine
- Press and hold down the foot switch; do not touch the driving/steering control handle trigger; try to drive and steer the machine

Result:

- It should not be possible to activate the driving and steering functions
- Select HARE speed.
- Raise the jib slightly for better visibility
- Press and hold down the foot switch; press and hold down the driving/steering control handle trigger
- Drive the machine forward and brake; assess and remember the machine's braking distance
- Drive the machine forward, test the steering and brake

Result:

- It should be possible to activate the driving and steering functions
- Driving and steering should function properly and smoothly
- The brakes should function properly
- The driving speed must be HARE speed.
- Reverse the machine for a short distance and brake

Result:

- Driving should function properly and smoothly.
- The brakes should function properly.
- The driving speed must be RAMP speed.
- Select TORTOISE speed.
- Drive the machine forward and brake; assess and remember the machine's braking distance
- Reverse the machine for a short distance and brake

Result:

- Driving should function properly and smoothly.
- The brakes should function properly
- The driving speed must be TORTOISE speed.
- Select RAMP speed.
- Drive the machine forward and brake; assess and remember the machine's braking distance
- Reverse the machine for a short distance and brake

Result:

- Driving should function properly and smoothly.
- The brakes should function properly
- The driving speed must be RAMP speed.
- Align the front wheels
- Release the foot switch.

WORKING POSITION SPEED

REMINDER: the diesel engine is started; the machine is in the TRANSPORT position; the turntable and the platform are in the NEUTRAL position; the jib is slightly raised.

REMINDER: RAMP speed is selected; the front and rear wheels are aligned.

- Select TORTOISE speed.
- Drive the machine a short distance forward and brake; assess and remember the machine's speed
- Raise the main/secondary arm for 3 seconds
- Drive the machine forward for a short distance and brake

Result:

- The driving speed must be WORKING POSITION speed
- Fully lower the main/secondary arm
- Drive the machine forward for a short distance and brake

Result:

- The driving speed must be TORTOISE speed.
- Extend the telescope for 3 seconds
- Drive the machine forward for a short distance and brake

Result:

- The driving speed must be WORKING POSITION speed
- Fully retract the telescope
- Drive the machine forward for a short distance and brake

Result:

- The driving speed must be TORTOISE speed.

DIFFERENTIAL LOCK

REMINDER: the diesel engine is started; the machine is in the TRANSPORT position; the turntable and the platform are in the NEUTRAL position; the jib is slightly raised.

REMINDER: TORTOISE speed is selected; the front and rear wheels are aligned.

- Drive the machine forward and steer fully to the left or right.
- Press and release the differential lock button

Result:

- The rear right-hand wheel or the rear left-hand wheel should slip
- The differential lock warning light should come on
- Press and release the differential lock button

Result:

- The wheels should no longer slip
- The differential lock warning light should go out
- Align the front wheels
- Brake the machine
- Press and release the differential lock button

Result:

- The differential lock warning light should come on
- Wait at least 2 seconds

Result:

- The differential lock warning light should go out

DRIVING ON A SLOPE AND TILT ALARM

REMINDER: the diesel engine is started; the machine is in the TRANSPORT position; the turntable and the platform are in the NEUTRAL position; the jib is slightly raised.

REMINDER: TORTOISE speed is selected; the front and rear wheels are aligned.

TEST No. 1

- Select a slope between 20% (11.3°) and 30% (16.7°).
- Select RAMP speed.
- Raise the jib to the horizontal position
- Drive the machine forward slowly onto the slope, facing it, with the platform at the bottom of the slope

Result:

- The audible alarm should sound intermittently
 - The tilt warning indicator lamp should flash
- Brake the machine on the slope

Result:

- The brakes should function properly
 - The machine should come to rest on the slope for at least 1 minute
- Try to raise the main/secondary arm and extend the telescope

Result:

- It should not be possible to activate the machine's functions
- Reverse slowly to drive the machine off the slope onto a level surface

Result:

- The audible alarm should stop
 - The tilt warning indicator lamp should go out
- Brake the machine

TEST No. 2

- Extend the telescope for three seconds
- Drive the machine forward slowly onto the slope, facing it, with the platform at the bottom of the slope

Result:

- The machine should brake automatically
 - The audible alarm should sound intermittently
 - The tilt warning indicator lamp should flash
- Try to raise the main/secondary arm, extend the telescope, tilt the platform/jib up/down and drive/steer

Result:

- It should not be possible to activate the machine's functions
- Fully retract the telescope

Result:

- It should be possible to activate the function
- Reverse slowly to drive the machine off the slope onto a level surface

Result:

- The audible alarm should stop
 - The tilt warning indicator lamp should go out
- Brake the machine
 - Fully lower the jib
 - Get out of the platform
 - Switch the machine off

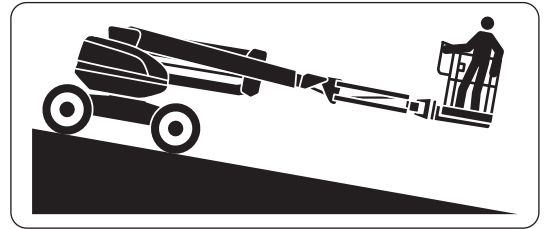

⚠ IMPORTANT ⚠

Select a test area on a firm, level surface that is free of any obstacles.
Identify and shut the machine down if a malfunction is detected.

FIRST VERSION "SAFEMANSYSTEM"

- Switch on the machine.

Result:

- The audible alarm should sound once.
- The flashing light SPS ① should flash several times and stop

- Get into the platform and start the diesel engine

- Extend the telescope for 5 seconds

- Turn the platform to the right or left, at the same time pressing the safety edge SPS ② and then release it

Result:

- The platform rotation should stop
- The horn should sound intermittently and the flashing light SPS should flash
- It should not be possible to activate the controls
- AUTOMATIC TELESCOPE RETRACTION option (depending on version): the telescope should retract automatically in less than 4 seconds.

- Press and release the reset button SPS ③.

Result:

- The horn should stop sounding and the flashing light SPS should stop flashing
- It should be possible to activate the controls

- Extend the telescope for 5 seconds

- Turn the turntable to the right or left, at the same time pressing the safety edge SPS ② and hold it down

Result:

- The platform rotation should stop
- The horn should sound intermittently and the flashing light SPS should flash
- It should not be possible to activate the controls
- AUTOMATIC TELESCOPE RETRACTION option (depending on version): the telescope should retract automatically in less than 4 seconds.

- Maintain pressure on the safety edge SPS ② and, at the same time, press and release the reset button SPS ③.

Result:

- The horn and the flashing light SPS should continue to operate
- It should be possible to activate the controls

- Release the safety edge SPS

Result:

- The horn should stop sounding and the flashing light SPS should stop flashing

- Put the machine in TRANSPORT position, put the turntable and the platform in NEUTRAL position and fully lower the jib

- Get out of the platform

- Stop the diesel engine and power down the machine

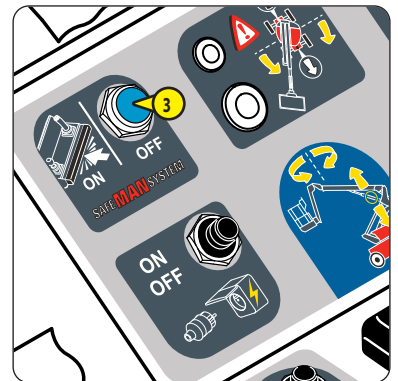
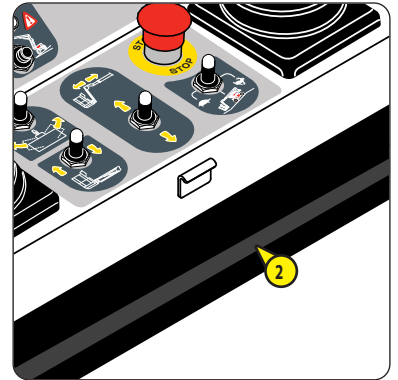

SECOND VERSION

- Switch on the machine.

Result:

- The audible alarm should sound once.
- The flashing light SPS ① should flash several times and stop

NOTE: if the safety cable SPS ② is defective, the flashing light SPS ① flashes rapidly and the audible alarm sounds intermittently. The machine can function normally, but the option is deactivated.

- Get into the platform and start the diesel engine
- Check the condition of the safety cable SPS ②; if there is any doubt about its condition, have it replaced by an approved professional from the Manitou network
- Extend the telescope for 5 seconds
- Turn the platform to the right or left, at the same time pushing the safety cable SPS ② forward, then release it

Result:

- The platform rotation should stop
- The horn should sound intermittently and the flashing light SPS should flash
- It should not be possible to activate the controls
- AUTOMATIC TELESCOPE RETRACTION option (depending on version): the telescope should retract automatically in less than 4 seconds.

- Press and release the reset button SPS ③.

Result:

- The horn should stop sounding and the flashing light SPS should stop flashing
- It should be possible to activate the controls

- Extend the telescope for 5 seconds
- Turn the platform to the right or left, at the same time pushing the safety cable SPS ② forward

Result:

- The platform rotation should stop
- The horn should sound intermittently and the flashing light SPS should flash
- It should not be possible to activate the controls
- AUTOMATIC TELESCOPE RETRACTION option (depending on version): the telescope should retract automatically in less than 4 seconds.

- Maintain pressure on the safety cable SPS ② and, at the same time, press and release the reset button SPS ③.

Result:

- The horn and the flashing light SPS should continue to operate
- It should be possible to activate the controls

- Release the safety cable SPS

Result:

- The horn should stop sounding and the flashing light SPS should stop flashing
- Put the machine in TRANSPORT position, put the turntable and the platform in NEUTRAL position and fully lower the jib
- Get out of the platform
- Stop the diesel engine and power down the machine

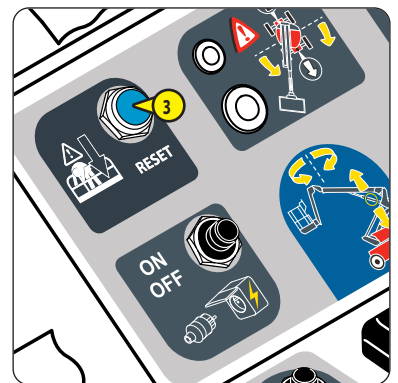
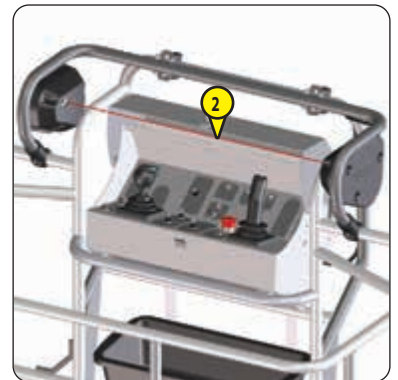



MONTHLY MAINTENANCE OR EVERY 50 HOURS OF SERVICE

ALSO PERFORM THE DAILY MAINTENANCE.

CHECK

Injection pipes, fuel hoses and the hose clamps

⚠ IMPORTANT ⚠

Never smoke or approach with a flame during this check.

If there is doubt about the condition of the injection pipes, fuel hoses and hose clamps, have them replaced by an authorized professional from the Manitou network.

- Open the right-hand turntable cover
- Remove the rear chassis cover
- Remove the left chassis cover
- Check the condition of all the injection pipes, fuel hoses and the tightening clamps
- Check for fuel leaks
- Refit the left chassis cover
- Refit the rear chassis cover
- Close the right-hand turntable cover

CHECK

Wheel nut tightening

⚠ IMPORTANT ⚠

Failure to follow this instruction may result in the machine tipping over.

- Check the tightening torques of all the wheel nuts:
 - 250 N.m \pm 25 N.m

CHECK

230 V electric power socket in the platform (OPTION)

⚠ IMPORTANT ⚠

Connect the plug to a 230 V/50 Hz power source delivering 16 A.

Only connect electrical appliances that work with 230 V/50 Hz, 16 A maximum.

Do not connect extension cords, power supply bars or plugs with multiple sockets to the electric power socket.

- Connect the plug ① to a power source.
- Plug an electrical appliance into the electric power socket ② and turn it on.

Result:

- The electrical appliance should operate.
- Open the electrical box cover panel ③A.
- Press and release the test button ③B.

Result:

- The switch ③C must move from the ON position to the OFF position, the indicators ③D and ③E should be green.
- The electrical appliance should not operate.
- Turn off the power to the electrical appliance.
- Push the switch ③C to the ON position.

Result:

- The switch must remain in the ON position, the indicators should be red.
- Switch the electrical appliance on.

Result:

- The electrical appliance should operate.
- Disconnect the electrical appliance.
- Disconnect the electrical plug.

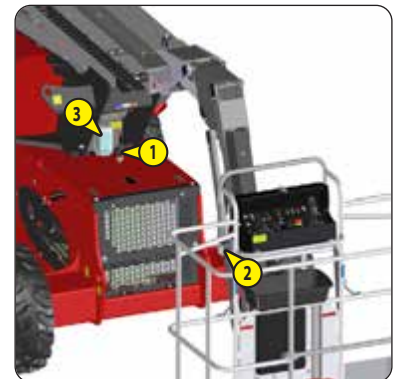

⚠ IMPORTANT ⚠

Only connect electrical appliances that work with:

- 110 V/50 Hz, 16 A maximum (110 V 3.5 kW electric generator option).

- 230 V/50 Hz, 16 A maximum (230 V 3.5 kW electric generator option).

Do not connect extension cords, power supply bars or plugs with multiple sockets to the electric power socket(s).

- Start the diesel engine.
- Start the electric generator.
 - Plug an electrical appliance into the electric power socket ① and turn it on.

Result:

- The electrical appliance should operate.

- Lift up the flap ②.
- Locate the electric generator ③.
- Press and release the test button ③A.

Result:

- The switch ③B must move from the ON position to the OFF position, the indicator ③C should be green.

- The electrical appliance should not operate.

- Turn off the power to the electrical appliance.
- Push the switch ③B to the ON position.

Result:

- The switch ③B must remain in the ON position, the indicator ③C should be red.

- Switch the electrical appliance on.

Result:

- The electrical appliance should operate.

- Disconnect the electrical appliance.
- Make sure the flap is in place
- Stop the generator.
- Switch off the machine.

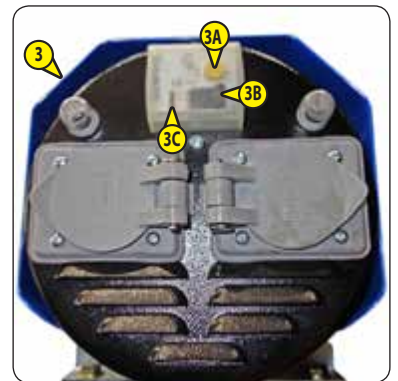
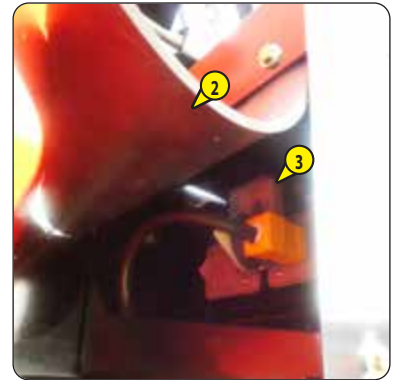

⚠ IMPORTANT ⚠

Clean the exterior air filter cartridge more often when the machine is operating in a dusty environment. If there is doubt about its condition, have it replaced by an approved professional from the Manitou network.

Never use the machine with a damaged air filter unit. If there is doubt about its condition, have it replaced by an approved professional from the Manitou network.

Never use the machine without the exterior air filter cartridge or if it is damaged. If there is doubt about its condition, have it replaced by an approved professional from the Manitou network.

Never use the machine without the interior air filter cartridge or if it is damaged. If there is doubt about its condition, have it replaced by an approved professional from the Manitou network.

If there is doubt about the condition of the air intake line, the air suction outlet hose and hose clamps, have them replaced by an authorized professional from the Manitou network.

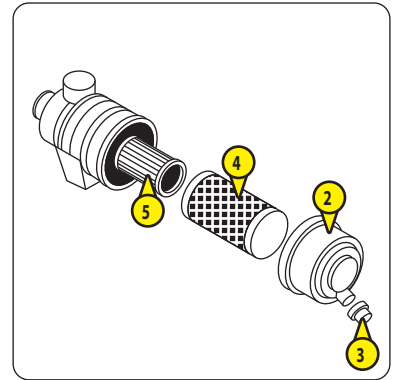

REMINDER: the rear chassis cover has been removed.

- Open the right-hand chassis cover
- Clean the outside of the air filter unit **1** with a clean, slightly damp cloth
- Unlock and remove the cover of the air filter unit **2**
- Clean the inside of the air filter unit cover with a clean, slightly damp cloth
- Remove the valve **3** and clean it
- Check the condition of the valve and replace it if it is damaged
- Put the valve back in place
- Remove the exterior air filter cartridge **4**, pulling it gently to prevent dust dispersion

NOTE: do not press the center of the interior air filter cartridge.

- Check the condition of the interior air filter cartridge **5** without taking it out
- Check the condition of the air filter unit, the air intake line, the air suction outlet hose and the tightening clamps
- Clean the exterior air filter cartridge **4** by tapping it gently

NOTE: if necessary, clean it with dry compressed air, from the inside out:

- Maximum pressure = 2 bar
- Minimum distance = 30 mm

- Check its condition and clean its seal with a clean cloth
- Refit it by pushing gently

NOTE: do not press the center of the exterior air filter cartridge

- Refit the air filter unit cover **2**, the valve **3** facing downward, the marking "TOP" facing upward
- Close the right-hand chassis cover
- Refit the rear chassis cover

CLEAN

Coolant and oil radiators

⚠ IMPORTANT ⚠

Clean the radiators more often when the machine is operating in a dusty environment.

If there is doubt about the condition of the hoses and hose clamps for the coolant and air radiators, it is essential to have them replaced by an authorized professional from the Manitou network.

- Remove the rear chassis cover
- Remove the ventilation grille ① and clean it with a clean, slightly damp cloth
- Clean the radiators ② with a small brush to remove the dust
- Clean them with compressed air, from the inside out
- Check the condition of the hoses and tightening clamps for the coolant and air radiators
- Check the condition of the oil radiator
- Put the ventilation grille back in place

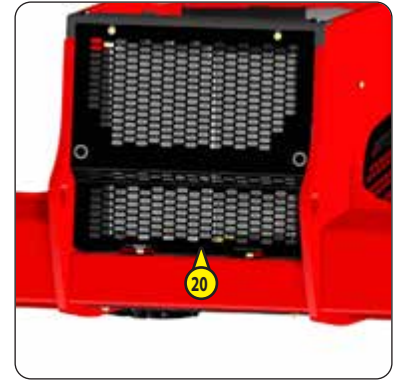

LUBRICATE

Steering pivots

⚠ IMPORTANT ⚠

Lubricate the axles more often when the machine is operating in a dusty environment.

- Remove the caps from the lubrication connectors ① on the steering pivots, on the right and left-hand sides
- Inject the lubricant into the lubrication connectors, LUBRICANTS AND FUEL
- Refit the caps of the lubrication connectors

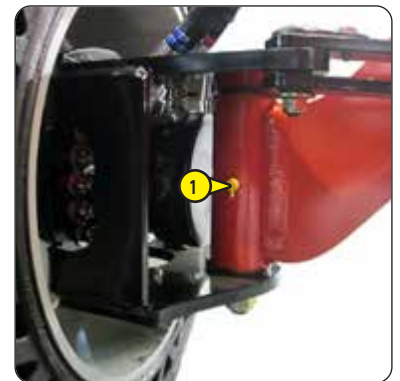

RESET

Maintenance warning

NOTE: it is not possible to reset the maintenance warning if it is not displayed. 2 - DESCRIPTION: GROUND LEVEL CONTROL PANEL SCREEN

- Switch the machine on
- Use the control keys to display the CODE menu
- Enter the access code
- Use the control keys to display the MAINTENANCE menu
- Use the control keys to reset the corresponding maintenance warnings.
- Use the control keys to return to the WORK PAGE.
- Switch the machine off

NB: 2 - DESCRIPTION: GROUND LEVEL CONTROL PANEL SCREEN: NAVIGATING THE MENUS

➔ 1 250H - PERIODIC MAINTENANCE - EVERY 250 HOURS OF SERVICE OR 6 MONTHS

ALSO PERFORM THE DAILY MAINTENANCE.

CHECK

Injection pipes, fuel hoses and the hose clamps

⚠ 50H: MONTHLY MAINTENANCE OR EVERY 50 HOURS OF SERVICE.

CHECK

Wheel nut tightening

⚠ 50H: MONTHLY MAINTENANCE OR EVERY 50 HOURS OF SERVICE.

CHECK

230 V electric power socket in the platform (OPTION)

⚠ 50H: MONTHLY MAINTENANCE OR EVERY 50 HOURS OF SERVICE.

CHECK

Electric generator (OPTION)

⚠ 50H: MONTHLY MAINTENANCE OR EVERY 50 HOURS OF SERVICE.

CHECK

Alternator/fan belt

⚠ IMPORTANT ⚠

If there is doubt about the condition of the belt, ⚠ 500H: REPLACE: ALTERNATOR/FAN BELT.

- Remove the rear chassis cover
- Check the condition of the belt ①; ensure there are no cracks or signs of wear
- Check the belt tension between the crankshaft pulley and the alternator pulley:
 - Apply pressure with the thumb = 98 N. The clearance A must be between 7 mm and 9 mm to be correct
- Adjust if necessary:
 - Loosen the screws ②
 - Adjust the belt tension by swiveling the alternator
 - Tighten the screws ②
- Check the belt tension again
- Refit the rear chassis cover

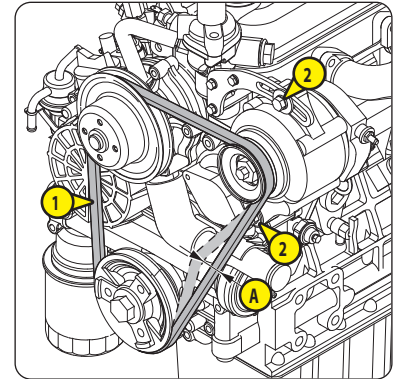

CHECK

Tightening of wheel motor fixing screws

⚠ IMPORTANT ⚠

Not observing this instruction may cause failure of the fixing screws and damage to the wheel motors.

NOTE: check the wheel motors one by one.

- Remove a wheel, OCCASIONAL MAINTENANCE: REPLACE WHEELS
- Check the wheel motor for leaks
- If a leak is detected:
 - Inspect the wheel motor and repair it if necessary, Machine REPAIR MANUAL
- Check the tightening torques of all the fixing screws :
 - 85 N.m ±8.5 N.m
- Put the wheel back in place, OCCASIONAL MAINTENANCE: REPLACE WHEELS
- Repeat the steps to check all the wheel motors

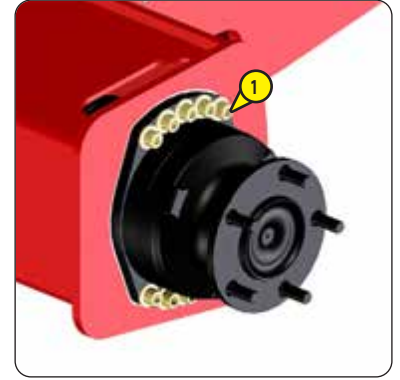

CHECK

Tightening of the screws that fix the steering cylinder to the chassis

⚠ IMPORTANT ⚠

Failure to follow this instruction may cause the machine to tip over.

- Check the tightening torques of all the fixing screws :
 - 255 N.m ±25.5 N.m

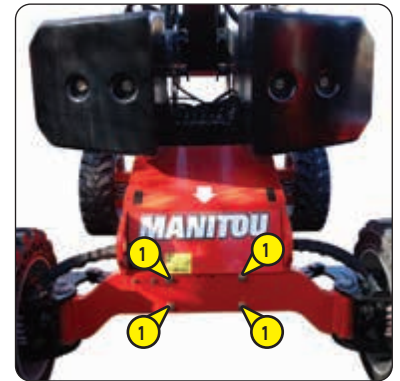

CHECK

Overload alarm

⚠ IMPORTANT ⚠

Refer to the machine repair manual if the overload alarm is not correctly calibrated.

REMINDER: the machine is in TRANSPORT position; the turntable and the platform are in NEUTRAL position; the jib is fully lowered

- Start the diesel engine
 - Place a uniformly distributed 253 kg load in the platform
- Result:
- The overload alarm should go off
- Remove 23 kg from the platform to obtain a load of 230 kg
- Result:
- The overload alarm should stop
- Remove the whole load from the platform

REMINDER: the diesel engine is started; the machine is in the TRANSPORT position; the turntable and the platform are in the NEUTRAL position; the jib is completely lowered.

PLACING IN FREEWHEEL MODE

- Perform the freewheel and brake function restoration procedure, ⚠ OCCASIONAL OPERATION: WINCH THE MACHINE

STOPPING DISTANCE ON LEVEL GROUND

- Place a uniformly distributed load in the platform:
 - Put 230 kg less the operator's weight
- Get into the platform
- Drive the machine forward, reach maximum speed and then release the joystick to stop the machine

Required results:

	Stopping distance
TRANSPORT position: HARE speed 	1400 mm ±300mm
WORKING position: WORKING POSITION speed	200 mm ±50mm

CHECKING THE BRAKES ON A SLOPE

- Place the machine in TRANSPORT position
- Raise the jib to the horizontal position
- Select RAMP speed 
- Drive the machine forward slowly on a 25% (14°) slope, facing it, with the platform at the bottom of the slope
- Brake the machine on the slope
- Switch off the diesel engine

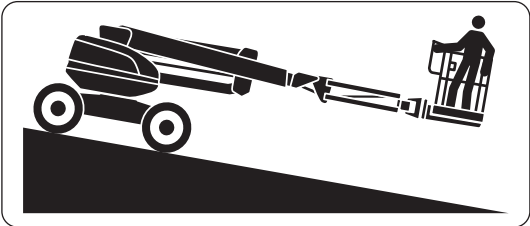

Result:

- The machine must not have moved backward after 1 minute
- Start the diesel engine
- Drive the machine off the slope onto a level surface
- Fully lower the jib
- Get out of the platform
- Remove the whole load from the platform
- Switch the machine off

CHECK

Turntable rotation motor oil level

- Open the left-hand turntable cover
- Check no oil is leaking from the turntable rotation motor ①
- Remove the filler plug ②
- Clean the dipstick on the filler cap with a clean cloth and put it back in place
- Remove the filler plug; the level is correct when the oil is between the 2 marks A and B
- If the level is low, add oil until the correct level is reached, LUBRICANTS AND FUEL
- Refit the filler cap
- Close the left-hand turntable cover.

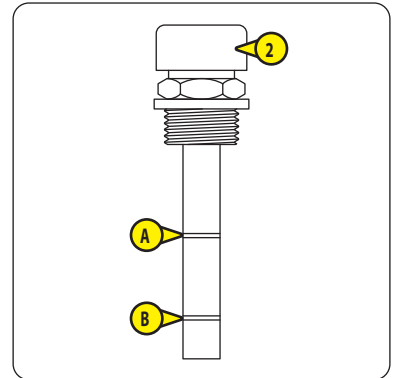

CHECK

Emergency controls

⚠ IMPORTANT ⚠

Use of the machine if there is a malfunction is prohibited.

- Check that the emergency controls are working, 2 - DESCRIPTION: RESCUE PROCEDURE

⚠ IMPORTANT ⚠

*Never smoke or approach with a flame when the fuel filter cartridge is being cleaned.
The diesel engine must be switched off and cold.*

Risk of fuel spatter (pressurized circuit).

*Never use the machine without the fuel filter cartridge or if it is damaged. If there is doubt about its condition,
⚠ 500H: REPLACE: fuel filter cartridge.*

NOTE: the machine is off and the engine is cold.

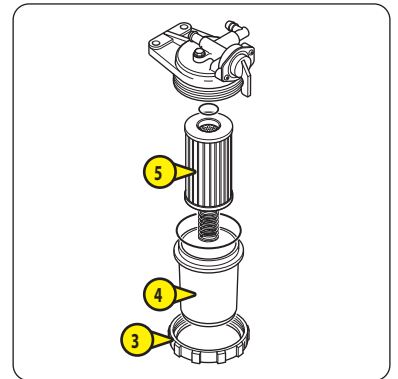
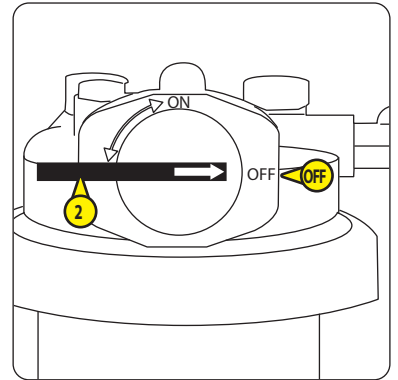

- Remove the left chassis cover
- Clean the outside of the fuel filter ① with a clean cloth
- Turn the tap ② to the position OFF
- Unscrew the retaining ring ③
- Remove the tank ④ and the fuel filter element ⑤; clean them with clean fuel, ⚠ LUBRICANTS AND FUEL
- Check their condition
- Check the condition of the fuel hoses and the hose clamps
- Refit the fuel filter cartridge, tank and retaining ring
- Bleed the fuel supply circuit, ⚠ OCCASIONAL MAINTENANCE
- Refit the left chassis cover



⚠ IMPORTANT ⚠

Always secure the raised arms using a suitable lifting device.

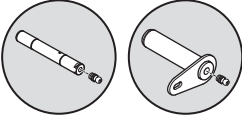
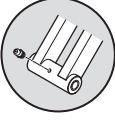
- Start the diesel engine
- Perform the appropriate movements of the main/secondary arm, the jib and the platform/jib tilting to access the various lubricators; secure the raised arm and the raised jib using a suitable lifting device
- Remove the caps of the lubrication connectors
- Inject the lubricant into each lubrication connector, ↙ LUBRICANTS AND FUEL
- Refit the caps of the lubrication connectors
- Tilt the platform/jib up/down until the platform floor is horizontal; fully lower the main/secondary arm and the jib
- Switch the machine off

KEY	
AXIS 	
HUB 	
CYLINDER RING 	

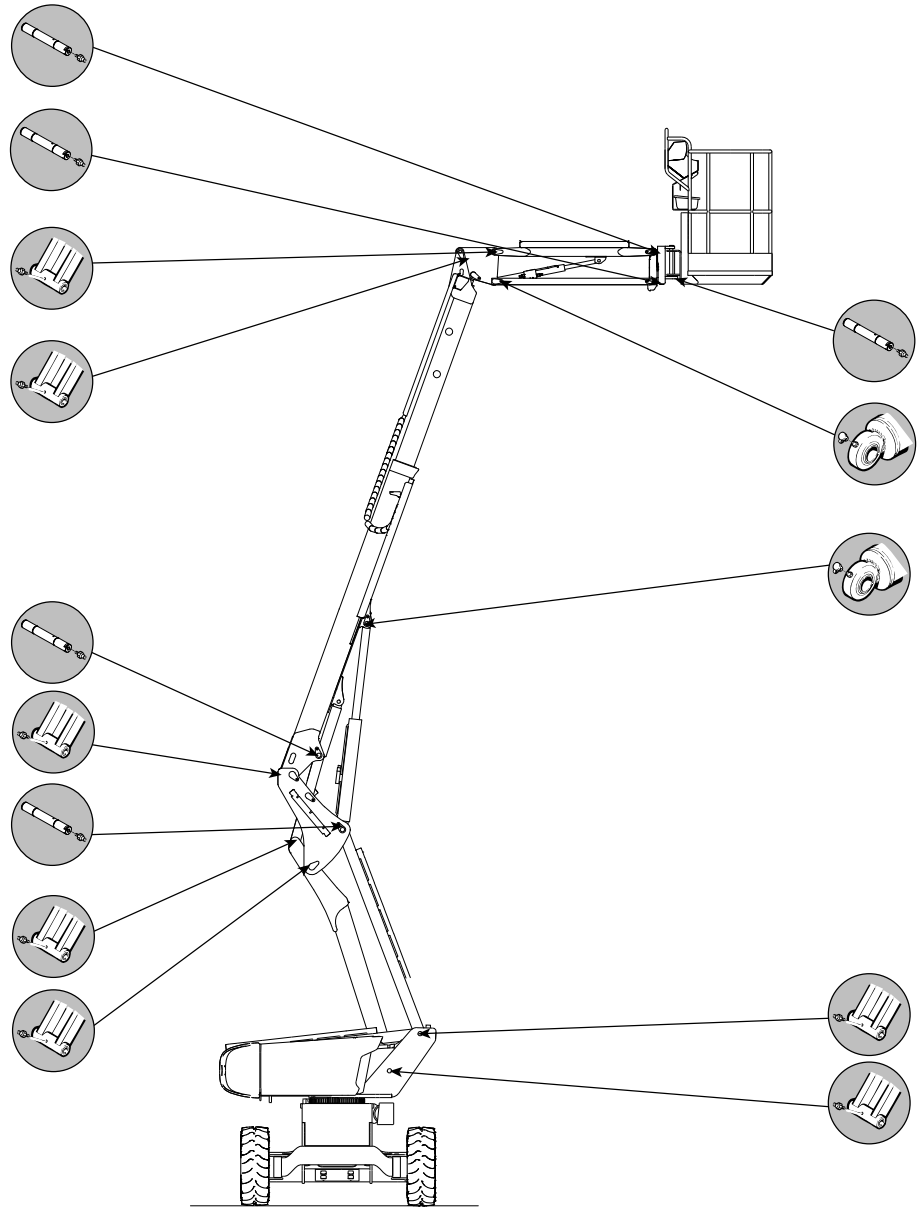

LUBRICATE

Telescope

⚠ IMPORTANT ⚠

Lubricate the telescope more often when the machine is operating in a dusty environment.

- Start the diesel engine
- Raise the jib slightly
- Fully extend the telescope

NOTE: ensure that the platform does not hit the ground; raise the jib again if necessary.

- Check the sliding surfaces **A** of the pads:
 - Surfaces must be smooth and free from corrosion
- Lubricate the telescope if necessary, LUBRICANTS AND FUEL

NOTE: retract and extend the telescope several times to spread the lubricant; remove the excess with a clean cloth.

- Fully retract the telescope
- Fully lower the jib
- Switch the machine off

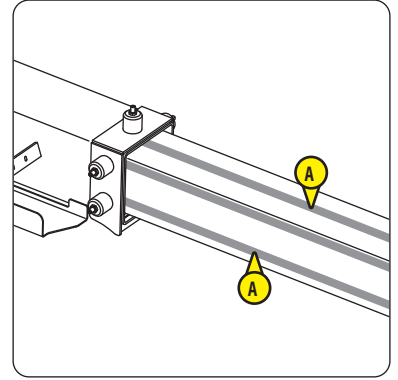

LUBRICATE

Crown gear

- Open the left and right-hand turntable covers
- Remove the caps of the 2 lubrication connectors **1** for the crown gear
- Inject the lubricant into the lubrication connectors, LUBRICANTS AND FUEL
- Start the diesel engine
- Turn the turntable 90° to the left or the right and inject lubricant again
- Refit the caps of the lubrication connectors
- Close the left and right turntable covers
- Lubricate the teeth of the crown gear **2**, LUBRICANTS AND FUEL
- Turn the turntable a full turn to spread the lubricant
- Put the turntable in NEUTRAL position
- Switch the machine off

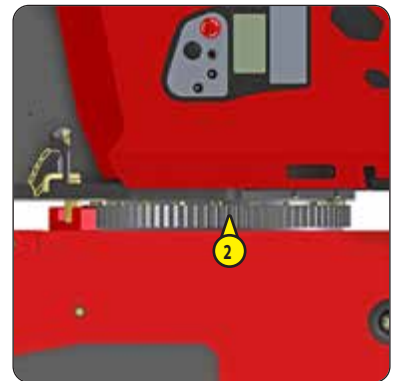

RESET

Maintenance warning

 50H: RESET: MAINTENANCE WARNING.

🔄 500H - PERIODIC MAINTENANCE - EVERY 500 HOURS OF SERVICE OR 1 YEAR

ALSO PERFORM THE DAILY SERVICE AND THE PERIODIC SERVICE AT 250 HOURS OF SERVICE.

CHECK

Tilt sensor (from machine MAN00000K01079391)

⚠️ IMPORTANT ⚠️

Failure to follow this instruction may result in the machine tipping over.

The machine must be in transport position with the turntable and the platform in neutral position and with the jib arm fully lowered.

- Start the diesel engine.
- Place the machine on a level surface.
- Access the "tilt calibration" menu on the ground level display screen.
- Check that the value displayed is $0^\circ \pm 0.3^\circ$.
- If the value is within the tolerances: return to the work page.
- If the value is outside the tolerances: refer to the machine repair manual to calibrate the tilt sensor.
- Switch off the machine.

CHECK

Tightening of the platform fixing screws

⚠️ IMPORTANT ⚠️

Failure to follow this instruction may result in the platform falling.

- Check the tightening torques of all the fixing screws 
 - $76.5 \text{ N.m} \pm 7 \text{ N.m}$

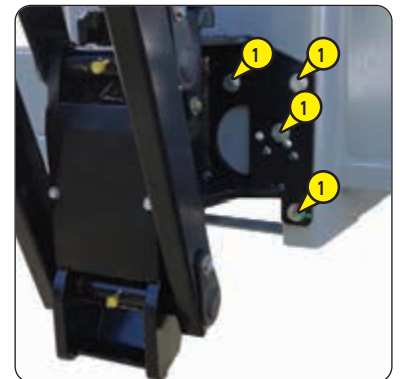
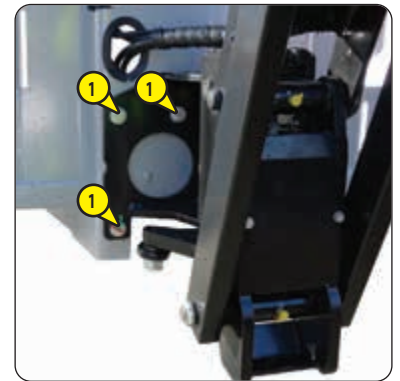

⚠ IMPORTANT ⚠

*It is recommended that the telescope wedging is adjusted if the clearances are higher than the maximum values, **REPAIR MANUAL.***

- Check the tightening torques of all the nuts **1**:
 - 69 N.m ±6.9 N.m
 - Start the diesel engine
 - Raise the jib slightly
 - Extend the telescope for 1 second
 - Check the clearances between the pads and the telescope:
 - **A** (upper pads **2**) must be between 1 mm and 1.5 mm
 - **B** (side pads **3**) must be between 0.5 mm and 0.75 mm on either side
 - Fully extend the telescope
- NOTE: ensure that the platform does not hit the ground; raise the jib again if necessary
- Check the clearances **A** and **B** again
 - Fully retract the telescope
 - Fully lower the jib
 - Take off the cover **4**
 - Raise the main/secondary arm slightly
 - Place several pallets under the platform
 - Slowly lower the main/secondary arm until the pads **5** are in contact with the main/secondary arm
 - Check the clearances between the pads and the main/secondary arm:
 - **C** (upper pads **6**) must be between 1 mm and 1.5 mm
 - **D** (side pads **7**) must be between 0.5 mm and 0.75 mm on either side
 - Raise the main/secondary arm slightly
 - Remove the pallets
 - Fully lower the main/secondary arm
 - Switch the machine off
 - Put the cover **4** back in place

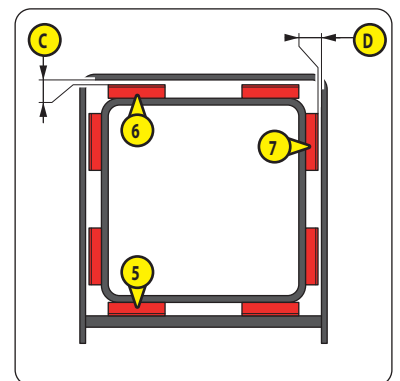
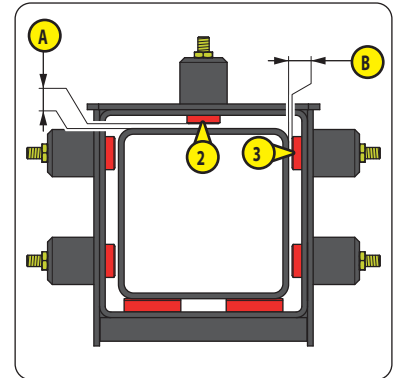
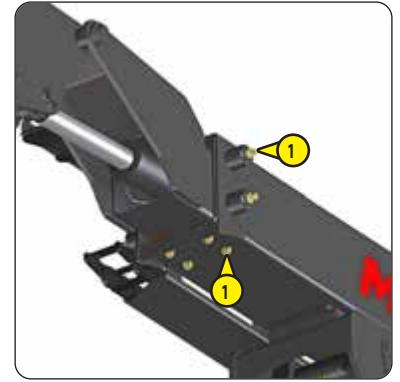

CHECK

Tightening of the fixing screws for the crown gear

⚠ IMPORTANT ⚠

*Failure to follow this instruction may result in the machine tipping over.
Always secure the raised secondary arm using a suitable lifting device.*

- Open the right-hand turntable cover
- Locate the drill hole **A**
- Open the left-hand turntable cover
- Locate the drill hole **B**
- Start the diesel engine
- Turn the turntable to align the drill holes **A** and **B** with 2 fixing screws **1**
- Check the tightening torques of the first 2 fixing screws **1**:
 - 117 N.m ± 11.7 N.m
- Turn the turntable to align the drill holes **A** and **B** with the 2 following fixing screws **1** to check their tightening torques
- Repeat the steps until the tightening torque for each fixing screw **1** has been checked
- Check the tightening torques of the fixing screws **2**:
 - 117 N.m ± 11.7 N.m
- Put the turntable in NEUTRAL position
- Switch the machine off

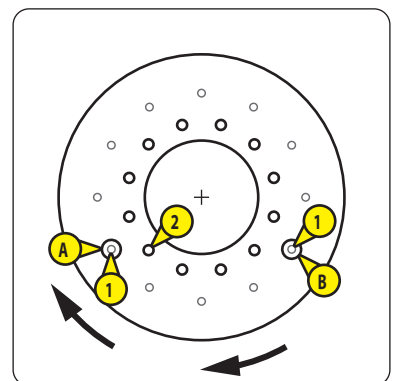
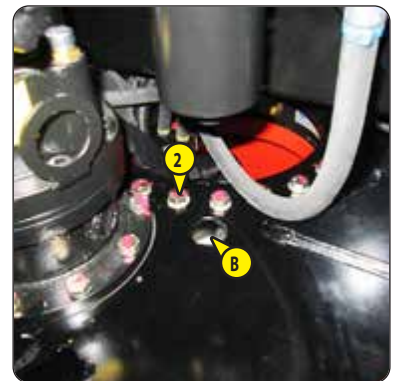
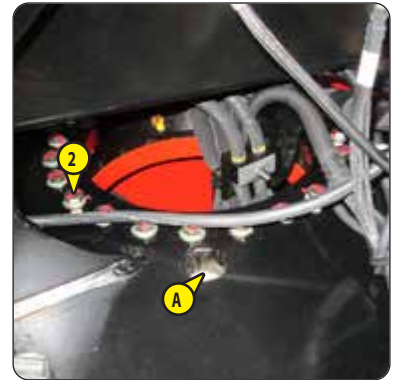
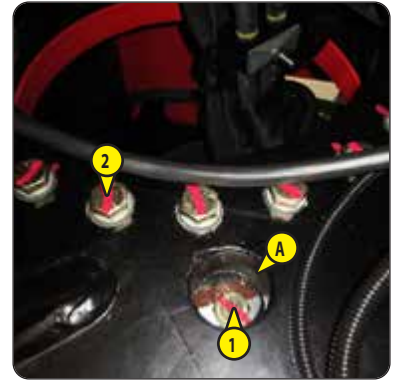

CHECK

Tightening of the fixing screws on the turntable rotation motor

⚠ IMPORTANT ⚠

*Failure to follow this instruction may result in involuntary movement of the turntable.
Always secure the raised secondary arm using a suitable lifting device.*

- REMINDER: the right and left turntable covers are open.
- Check the tightening torques of all the fixing screws **1**:
 - 96 N.m ± 9.6 N.m



CHECK

Counterweight fixing screw tightening

⚠ IMPORTANT ⚠

*Failure to follow this instruction may result in the machine tipping over.
Always secure the raised secondary arm using a suitable lifting device.*

REMINDER: the right and left turntable covers are open.

- Check the tightening torques of all the fixing screws ①:
 - 300 N.m ± 30 N.m



CHECK

Hydraulic hoses

⚠ IMPORTANT ⚠

*Always use a piece of paper or cardboard to check there are no hydraulic oil leaks.
Replace any damaged hydraulic hoses.*

REMINDER: the right and left turntable covers are open.

- Open the right-hand chassis cover
- Remove the left chassis cover
- Remove the front and rear chassis covers
- Check the condition of all the hydraulic hoses and that there are no leaks

REPLACE

Alternator/fan belt

REMINDER: the left and right turntable covers are open; the right chassis cover is open; the left, front and rear chassis covers have been removed.

- Replace the belt ①, FILTER CARTRIDGES AND BELTS:
 - Loosen the screws ②
 - Remove the used belt by swiveling the alternator
 - Replace it with a new belt
 - Tighten the screws ②
- Check the belt tension between the crankshaft pulley and the alternator pulley:
 - Apply pressure with the thumb = 98 N. The clearance ③ must be between 7 mm and 9 mm to be correct
- Adjust if necessary:
 - Loosen the screws ②
 - Adjust the belt tension by swiveling the alternator
 - Tighten the screws ②
- Check the belt tension again

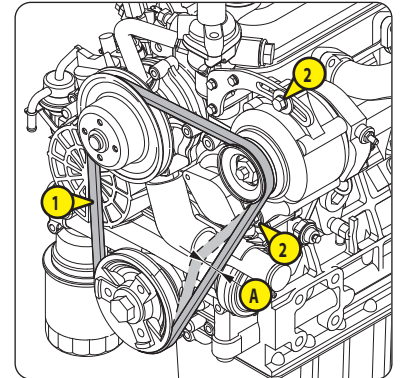

REPLACE

Fuel filter cartridge (pre-filter)

⚠ IMPORTANT ⚠

Never smoke or approach with a flame when the fuel pre-filter is being replaced.

REMINDER: the left and right turntable covers are open; the right chassis cover is open; the left, front and rear chassis covers have been removed.

- Locate the fuel filter cartridge (pre-filter) ① and put a drain pan underneath
- Replace the fuel filter cartridge (pre-filter), FILTER CARTRIDGES AND BELTS:
 - Remove the used fuel filter cartridge (pre-filter)
 - Check the condition of the fuel hoses and the hose clamps
 - Fit the new fuel filter cartridge (pre-filter); make sure the hose clamps are in place

NOTE: respect the fitting direction for the fuel filter cartridge (pre-filter) shown by an arrow.



REPLACE

Fuel filter cartridge

⚠ IMPORTANT ⚠

*Never smoke or approach with a flame when the fuel filter cartridge is being replaced.
Never use the machine without the fuel filter cartridge or if it is damaged.*

REMINDER: the left and right turntable covers are open; the right chassis cover is open; the left, front and rear chassis covers have been removed.

- Clean the outside of the fuel filter ① with a clean cloth
- Turn the tap ② to the position OFF
- Replace the fuel filter cartridge ⑤, FILTER CARTRIDGES AND BELTS:
 - Unscrew the retaining ring ③
 - Remove the tank ④ and the used fuel filter cartridge
 - Clean the tank with clean fuel, LUBRICANTS AND FUEL
 - Check its condition
 - Refit the new fuel filter cartridge, tank and retaining ring
- Check the condition of the fuel hoses and the hose clamps
- Bleed the fuel supply circuit, OCCASIONAL MAINTENANCE

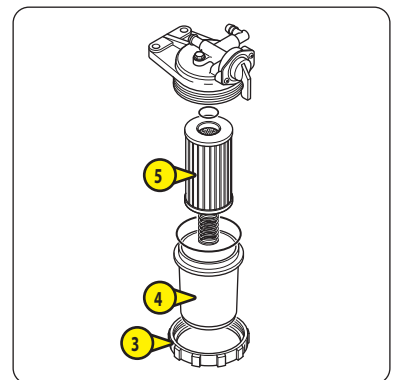
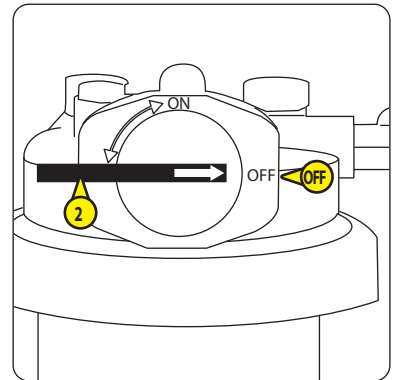

REPLACE

Diesel engine oil

REPLACE

Diesel engine oil filter cartridge

REMINDER: the left and right turntable covers are open; the right chassis cover is open; the left, front and rear chassis covers have been removed.

CHANGE THE OIL

- Remove the chassis cover ①
- Start the diesel engine
- Allow the diesel engine to run for 5 minutes
- Switch the machine off
- Locate the drain plug ② and put a drain pan underneath
- Remove the drain plug and the filler cap ③
- Wait until the crankcase is completely empty

REPLACE THE DIESEL ENGINE OIL FILTER

- Place a drain pan under the diesel engine oil filter cartridge ④
- Replace the diesel engine oil filter cartridge, FILTER CARTRIDGES AND BELTS:
 - Unscrew the used diesel engine oil filter cartridge
 - Lubricate the seal of the new engine oil filter cartridge with clean diesel engine oil, LUBRICANTS AND FUEL
 - Screw on the new diesel engine oil filter cartridge by hand and tighten it by three-quarters of a turn using the oil filter wrench

FILL THE DIESEL ENGINE

- Clean around the drain hole with a clean cloth
- Refit the drain plug
- Fill the diesel engine with new diesel engine oil, LUBRICANTS AND FUEL
- Wait 5 minutes for the oil to settle in the diesel engine crankcase
- Refit the filler cap
- Check the diesel engine oil level, DAILY MAINTENANCE: CHECK DIESEL ENGINE OIL LEVEL
- Start the diesel engine
- Allow the diesel engine to run for 5 minutes
- Check for leaks
- Switch the machine off
- Wait 5 minutes for the oil to settle in the diesel engine crankcase
- Check the diesel engine oil level again and top up if necessary, DAILY MAINTENANCE: CHECK DIESEL ENGINE OIL LEVEL
- Refit the chassis cover ①

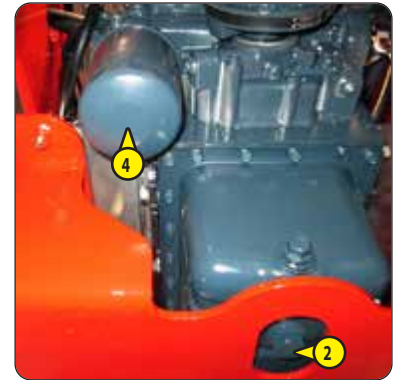
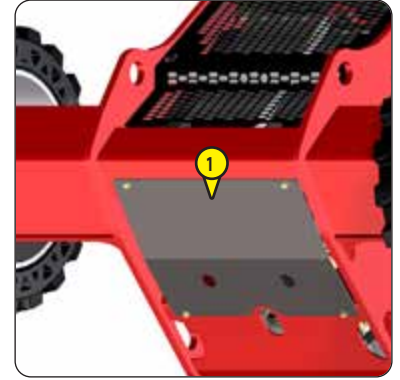

⚠ IMPORTANT ⚠

Never use the machine with a damaged air filter unit. Replace it if there is any doubt about its condition.

Never use the machine without the exterior air filter cartridge or if it is damaged.

Never use the machine without the interior air filter cartridge or if it is damaged. If there is doubt about its condition,

⚡ 1000H: REPLACE: INTERIOR AIR FILTER CARTRIDGE.

If there is doubt about the condition of the air intake line, the air suction outlet hose and hose clamps, ⚡ 1000H:

REPLACE: AIR INTAKE LINE AND AIR SUCTION OUTLET HOSE.

REMINDER: the left and right turntable covers are open; the right chassis cover is open; the left, front and rear chassis covers have been removed.

- Clean the outside of the air filter unit ① with a clean, slightly damp cloth
- Unlock and remove the cover of the air filter unit ②
- Clean the inside of the air filter unit cover with a clean, slightly damp cloth
- Remove the valve ③ and clean it
- Check the condition of the valve and replace it if it is damaged
- Put the valve back in place
- Remove the used interior air filter cartridge ④, pulling it gently to prevent dust dispersion

NOTE: do not press the center of the interior air filter cartridge.

- Check the condition of the interior air filter cartridge ⑤ without taking it out
- Check the condition of the air filter unit, the air intake line, the air suction outlet hose and the tightening clamps
- Replace the exterior air filter cartridge ④, ⚡ FILTER CARTRIDGES AND BELTS:
 - Clean the seal of the new exterior air filter cartridge with a clean cloth
 - Install the exterior air filter cartridge by pushing it gently

NOTE: do not press the center of the interior air filter cartridge.

- Refit the air filter unit cover ②, the valve ③ facing downward, the marking "TOP" facing upward

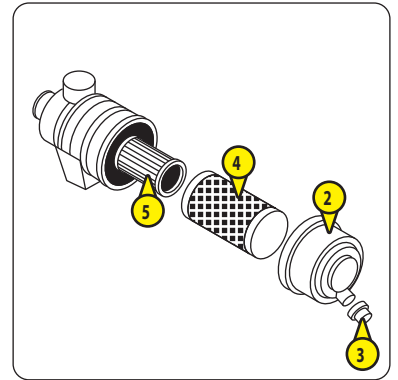
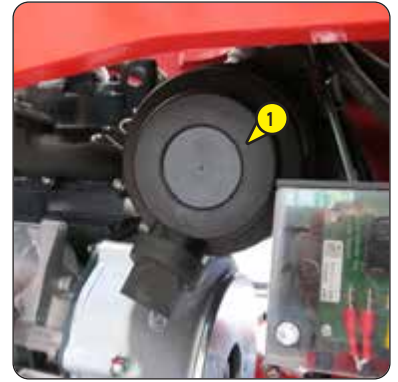

REPLACE

Turntable rotation motor oil

⚠ IMPORTANT ⚠

It is recommended that the oil is slightly warm before being changed.

REMINDER: the left and right turntable covers are open; the right chassis cover is open; the left, front and rear chassis covers have been removed.

CHANGE THE OIL

- Place a drain pan under the drain plug **1**
- Remove the drain plug and the filler cap **2**
- Wait until the crankcase is completely empty

FILL THE TURNTABLE ROTATION MOTOR

- Clean around the drain hole with a clean cloth
- Refit the drain plug
- Fill the turntable rotation motor with new oil, \triangleleft LUBRICANTS AND FUEL
- Clean the dipstick on the filler cap with a clean cloth and put it back in place
- Remove the filler plug; the level is correct when the oil is between the 2 marks **A** and **B**
- If the level is low, add oil until the correct level is reached, \triangleleft LUBRICANTS AND FUEL
- Refit the filler cap

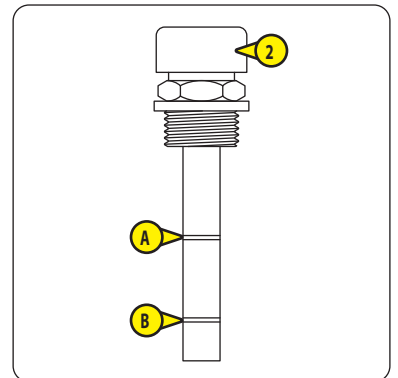

REPLACE

Hydraulic pressure filter cartridge

⚠ IMPORTANT ⚠

Never use the machine without the hydraulic pressure filter cartridge or if it is damaged.

REMINDER: the left and right turntable covers are open; the right chassis cover is open; the left, front and rear chassis covers have been removed.

- Clean the outside of the hydraulic pressure filter **1** with a clean cloth
- Place a drain pan underneath
- Replace the hydraulic pressure filter cartridge **2**, \triangleleft FILTER CARTRIDGES AND BELTS:
 - Unscrew the hydraulic pressure filter tank
 - Remove the used hydraulic pressure filter cartridge
 - Put the new hydraulic pressure filter cartridge in place
 - Put the hydraulic pressure filter tank back in place
- Start the diesel engine
- Lift/lower the main/secondary arm and the jib for several minutes
- Fully lower the main/secondary arms and the jib
- Check for leaks
- Switch the machine off
- Close the left and right turntable covers
- Close the right-hand chassis cover
- Refit the front and rear chassis covers



REPLACE

Hydrostatic transmission filter cartridge

⚠ IMPORTANT ⚠

Never use the machine without the hydrostatic transmission filter cartridge or if it is damaged.

REMINDER: the left chassis cover has been removed.

- Remove the chassis cover ①
- Clean the outside of the hydrostatic transmission filter ② with a clean cloth
- Place a drain pan underneath
- Replace the hydrostatic transmission filter cartridge ③, ⚠ FILTER CARTRIDGES AND BELTS:
 - Unscrew the hydrostatic transmission filter tank
 - Remove the used hydrostatic transmission filter cartridge
 - Put the new hydrostatic transmission filter cartridge in place
 - Put the hydrostatic transmission filter tank back in place
- Start the diesel engine
- Drive the machine forward and backward for several minutes
- Check for leaks
- Refit the chassis cover ①
- Refit the left chassis cover
- Check the hydraulic oil level, ⚠ DAILY MAINTENANCE: CHECK THE HYDRAULIC OIL LEVEL
- Switch the machine off

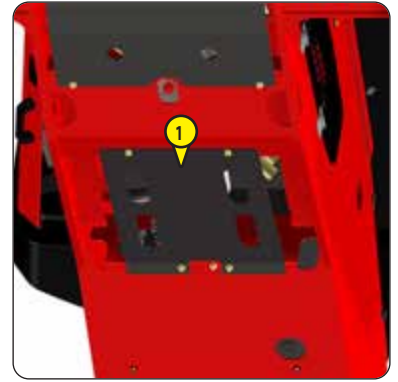

RESET

Maintenance warning

⚠ 50H: RESET: MAINTENANCE WARNING.

🔄 1000H - PERIODIC MAINTENANCE - EVERY 1000 HOURS OF SERVICE OR 2 YEARS

ALSO PERFORM THE DAILY SERVICE AND THE PERIODIC SERVICES AT 250 HOURS AND 500 HOURS OF SERVICE.

CLEAN

Fuel tank

⚠️ IMPORTANT ⚠️

Never smoke or approach with a flame when the fuel tank is being cleaned.

- Open the right-hand turntable cover
- Locate the drain plug ① and put a drain pan underneath
- Remove the drain plug and the tank plug ②
- Wait until the tank is completely empty
- Rinse the tank with 10 liters of clean fuel, \triangleleft LUBRICANTS AND FUEL
- Clean around the drain hole with a clean cloth
- Refit the drain plug
- Fill the tank completely with clean fuel, \triangleleft DAILY MAINTENANCE: CHECK FUEL LEVEL
- Refit the tank cap
- Bleed the fuel supply circuit, \triangleleft OCCASIONAL MAINTENANCE
- Close the right-hand turntable cover



REPLACE

Interior air filter cartridge

⚠️ IMPORTANT ⚠️

Never use the machine without the interior air filter cartridge or if it is damaged.

- Remove the rear chassis cover
 - Open the right-hand chassis cover
 - Follow the instructions described in 500H: REPLACE THE EXTERIOR AIR FILTER CARTRIDGE and replace the interior air filter cartridge ⑤, \triangleleft FILTER CARTRIDGES AND BELTS:
 - Remove the used exterior air filter cartridge, pulling it gently to prevent dust dispersion
 - Block the outlet of the air filter unit with a clean cloth
 - Clean the inside of the air filter unit with a clean, slightly damp cloth
 - Remove the cloth from the air filter unit outlet
 - Clean the seal of the new interior air filter cartridge with a clean cloth
 - Install the new interior air filter cartridge by pushing it gently
- NOTE: do not press the center of the interior air filter cartridge.

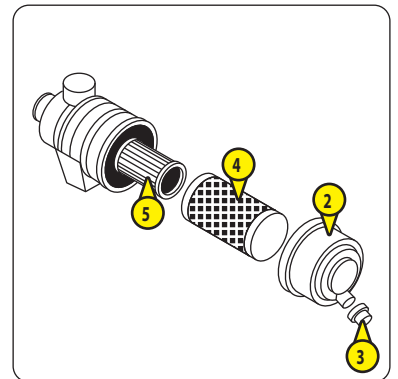

⚠ IMPORTANT ⚠

*Wait until the diesel engine cools if it has been running for a while.
Do not remove the radiator cap until the diesel engine is completely cooled.*

REMINDER: the right chassis cover is open and the rear chassis cover has been removed

DRAIN THE COOLANT

- Remove the chassis cover ①
- Locate the drain plug ② under the coolant radiator and put a drain pan underneath
- Locate the drain tap ③ near to the coolant radiator
- Open the drain tap ③
- Remove the drain plug ② and the radiator cap ④
- Wait until the cooling circuit is completely empty

FILL THE COOLING CIRCUIT

- Close the drain valve
- Clean around the drain hole with a clean cloth
- Refit the drain plug
- Fill the cooling circuit with new coolant, ◀ LUBRICANTS AND FUEL; the level is correct when the coolant reaches the top of the filling hole
- Refit the radiator cap
- Start the diesel engine
- Allow it to run for 5 minutes
- Check for leaks
- Switch the machine off
- Wait until the diesel engine cools
- Remove the radiator cap
- Check the coolant level and top up if necessary
- Refit the radiator cap
- Refit the chassis cover ①
- Close the right-hand chassis cover
- Refit the rear chassis cover

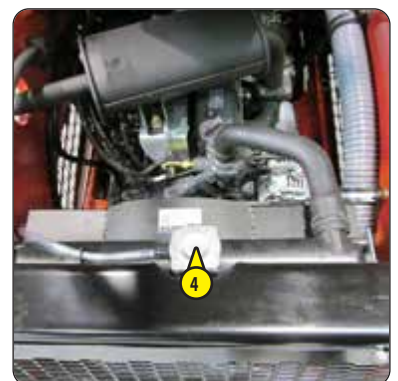
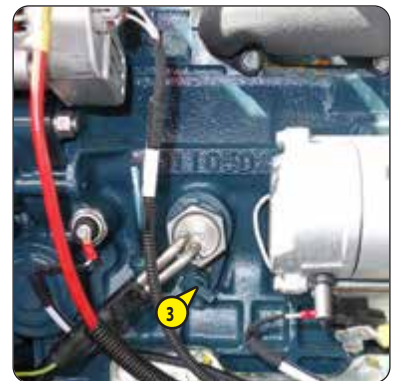
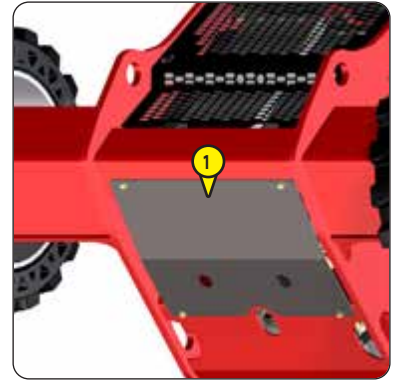

⚠ IMPORTANT ⚠

It is recommended that the oil is slightly warm before being changed.

There can be a difference in level of 10 mm to 20 mm between hot and cold oil. It is recommended the level is checked again when the hydraulic oil is hot.

Clean the oil can before adding oil to the hydraulic oil tank.

Use a clean funnel to add oil to the hydraulic oil tank.

CHANGE THE OIL

- Start the diesel engine
- Turn the turntable 90° to the left or the right
- Switch the machine off
- Remove the front chassis cover
- Remove the chassis cover ①
- Locate the drain plug ② under the machine's chassis and put a drain pan underneath
- Remove the drain plug and the tank plug ③
- Wait until the tank is completely empty

CLEAN THE FILLING FILTER AND SUCTION STRAINER

- Remove the filling filter ④
- Clean it with compressed air, from the outside in:
 - Maximum pressure = 3 bar
 - Minimum distance = 30 mm
- Check its condition and replace it if necessary, FILTER CARTRIDGES AND BELTS
- Refit the filling filter
- Locate the hydraulic hoses ⑤ and ⑥ and put a drain pan underneath
- Remove the hydraulic hoses and the suction strainers ⑦
- Clean the suction strainers with compressed air, from the inside out:
 - Maximum pressure = 3 bar
 - Minimum distance = 30 mm
- Check their condition and replace if necessary, FILTER CARTRIDGES AND BELTS
- Refit the suction strainers and the hydraulic hoses

FILL THE HYDRAULIC OIL TANK

- Refit the drain plug
- Fill the tank with new hydraulic oil, LUBRICANTS AND FUEL; the level is correct when the oil reaches the red dot on the level indicator ⑧
- Refit the tank cap
- Start the diesel engine
- Use the machine controls for 10 minutes
- Check for leaks
- Place the machine in TRANSPORT position
- Put the turntable and platform in NEUTRAL position
- Lower the jib completely.
- Check the hydraulic oil level; the level is correct when the oil reaches the red dot on the level indicator
- Add hydraulic oil if necessary
- Refit the chassis cover ①
- Refit the front chassis cover
- Switch the machine off

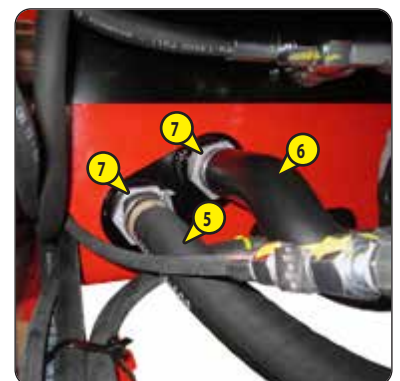
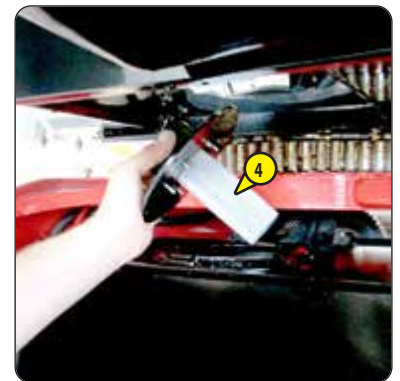
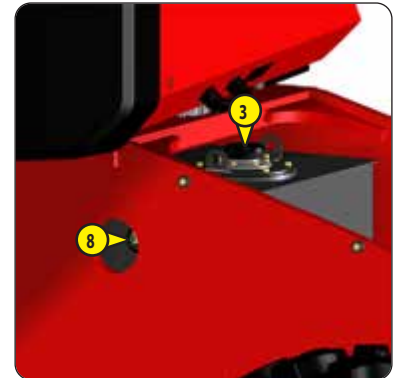
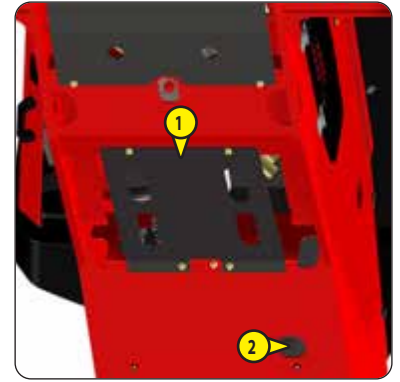

CHECK *Diesel engine silent blocks **

CHECK *Diesel engine speeds **

CHECK *Valve lash **

CHECK *Injection pump **

CHECK *Fuel injectors **

CHECK *Hydrostatic transmission circuit pressure **

CHECK *Clearance of slewing ring gear **

CHECK *Speeds of hydraulic movements **

CHECK *Condition of cylinders **

CHECK *Condition of electric wiring **

RESET *Maintenance warning*

⚠ 50H: RESET: MAINTENANCE WARNING.

** Consult your dealer.*

➡ ④ 2000H - PERIODIC MAINTENANCE - EVERY 2000 HOURS OF SERVICE OR 4 YEARS

ALSO PERFORM THE DAILY SERVICE AND THE PERIODIC SERVICES AT 250 HOURS, 500 HOURS AND 1000 HOURS OF SERVICE.

CHECK	Coolant and oil radiators *
CHECK	Water pump and thermostat *
CHECK	Alternator and starter *
CHECK	Hydraulic circuit pressures *
CHECK	Hydraulic circuit flow rates *
CLEAN	Hydraulic oil tank *
REPLACE	Air intake line and air suction hose *
REPLACE	Coolant radiator pipes and cable ties *
REPLACE	Rubber water pipes *
REPLACE	Injection pipes, fuel hoses and the hose clamps *
RESET	Maintenance warning

⚠ 50H: RESET: MAINTENANCE WARNING.

** Consult your dealer.*

↩ OCCASIONAL MAINTENANCE

REPLACE

Wheels

⚠ IMPORTANT ⚠

⚠ 2 - DESCRIPTION: SPECIFICATIONS and refer to the applicable stickers for information about the total weight of the machine and wheel load.

When lifting the machine with a mechanical or hydraulic jack:

- Always use a suitable jack for lifting the machine.
- Make sure that the 2 wheels on the opposite side to the lift are chocked.
- Position the jack near the wheel to be raised.
- Always use suitable jack stands to secure the raised machine.

⚠ IMPORTANT ⚠

Weight of a wheel = 96 kg

NOTE: we recommend the use of the hydraulic jack (MANITOU Part No. 505507) and the safety jack stand (MANITOU Part No. 554772).

- Loosen the wheel nuts slightly
- Lift the machine
- Remove the wheel nuts and the wheel
- Put the new wheel in place
- Refit the wheel nuts and tighten them slightly with a spanner
- Lower the machine to the ground
- Tighten the wheel nuts, ⚠ 50H: CHECK: WHEEL NUT TIGHTENING.



REPLACE

Fuses/relays

MAIN FUSE BOX

- Remove the front chassis cover
- Locate the main fuse box ①
- Remove the cover of the main fuse box
- Replace the fuse:

Ⓐ Main electrical power supply	250 A fuse
--------------------------------	------------

- Put the main fuse box cover back in place
- Refit the front chassis cover

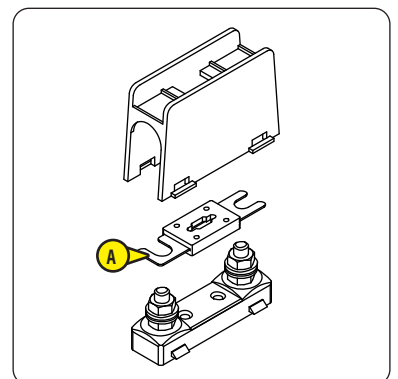

ENGINE FUSE/RELAY BOX

- Open the right-hand chassis cover
- Locate the engine fuse/relay box **2**
- Remove the cover of the engine fuse/relay box
- Replace the appropriate fuse/relay

A	Diesel engine preheat	60 A fuse
B	Ground level control panel	60 A fuse
F3	Engine immobiliser system (OPTION)	1 A fuse
K1	Engine preheat	12 V 40 A Relay

- Put the engine fuse/relay box cover back in place
- Close the right-hand chassis cover

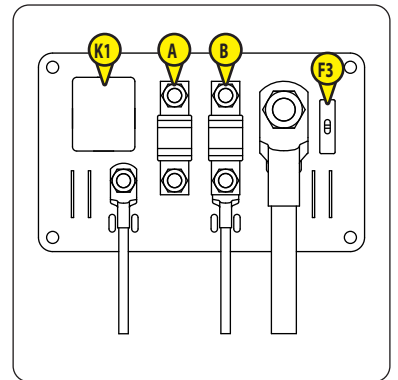

GROUND CONTROL PANEL FUSES/RELAYS

- Open the right-hand turntable cover
- Unlock and open the ground level control panel **3**
- Replace the appropriate fuse/relay

F1	Diesel engine starter button	5 A fuse
F2	Ground level control panel screen and control keys	5 A fuse
F3	Platform screen and control panel	5 A fuse
F4	Worklight power supply (OPTION)	5 A fuse
F6	Screen	5 A fuse
F7	Ignition switch	10 A fuse
F8	Diesel engine power supply	30 A fuse
K1	Engine immobilizer system (OPTION)	12 V 35 A Relay
K2	Engine stop	12 V 35 A Relay

- Close the ground control panel
- Close the right-hand turntable cover

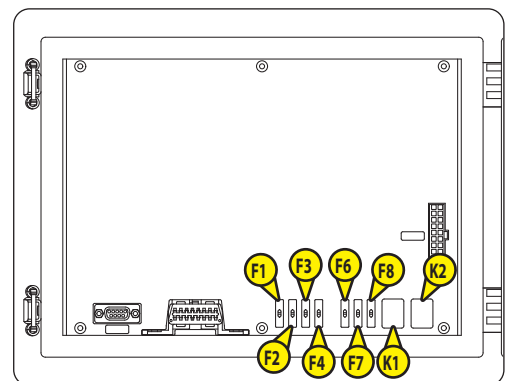
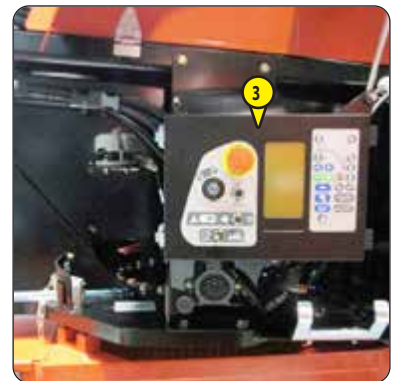

⚠ IMPORTANT ⚠

Never smoke or approach with a flame when the fuel supply circuit is being bled.

Always bleed the fuel supply circuit when:

- *The fuel tank has been drained and then filled.*
- *There has been a fuel breakdown and then the fuel tank has been filled.*
- *A component of the fuel supply circuit has been cleaned or replaced.*

If the engine runs irregularly or stops after bleeding the fuel supply circuit, check the condition of the entire fuel supply circuit.

BLEED THE FUEL FILTER

- Remove the left chassis cover
- Place a drain tank under the fuel filter **1**.
- Turn the tap **2** to the position **ON**
- Unscrew the bleeder screw **3**
- Locate the fuel pump **4**
- Operate the manual pump **5** until fuel runs out of the bleeder screw
- Continue pumping and tighten the bleeder screw

BLEED THE INJECTION PUMP

- Locate the bleeder screw **6** and put a drain pan underneath
- Unscrew the bleeder screw
- Operate the manual pump **5** until fuel runs out of the bleeder screw
- Continue pumping and tighten the bleeder screw
- Start the diesel engine
- Allow it to run for 5 minutes
- Check for leaks
- Switch the machine off
- Refit the left chassis cover

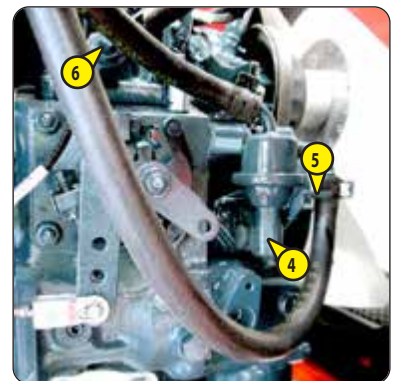
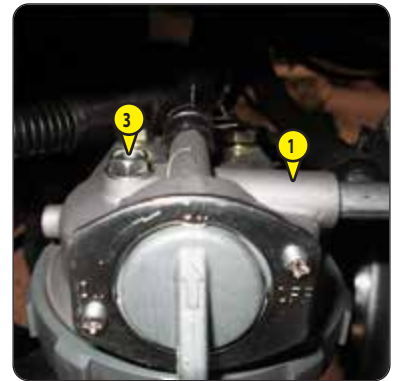
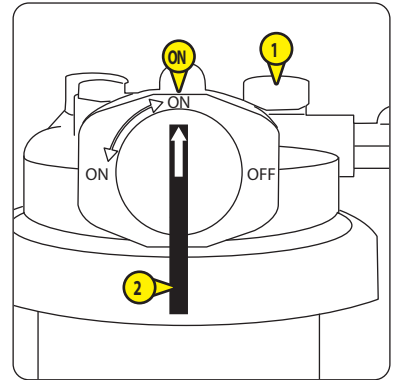

WINCH

Machine

⚠ IMPORTANT ⚠

Towing of the machine is prohibited.

The machine must be winched in transport position. Winching the machine in working position is prohibited,

◀ 2 - DESCRIPTION: OPERATING THE MACHINE: TRANSPORT/WORKING POSITION.

Always use a suitable winch for winching the machine.

Before releasing the brakes:

- The machine must be on a level surface.

- The wheels must be chocked.

The platform must be empty when the machine is being winched.

NB: ◀ 2 - DESCRIPTION: STICKERS: FREEWHEEL AND WINCHING PROCEDURE **D** and FREEWHEEL AND WINCHING PROCEDURE - HYDROSTATIC PUMP **C**.

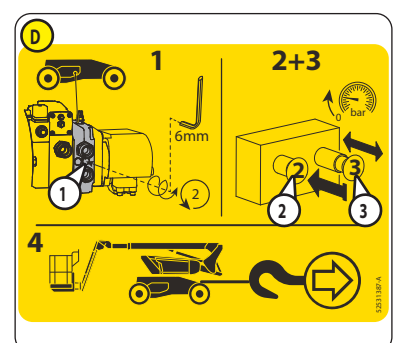
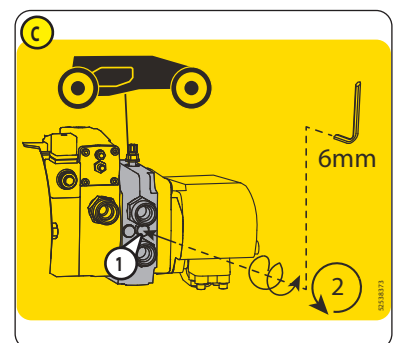
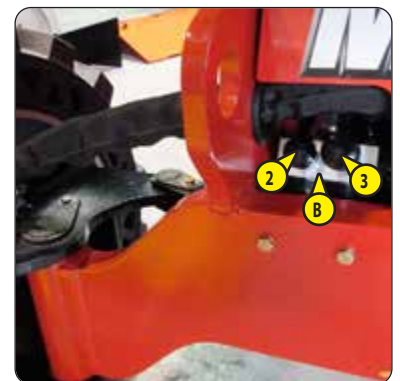
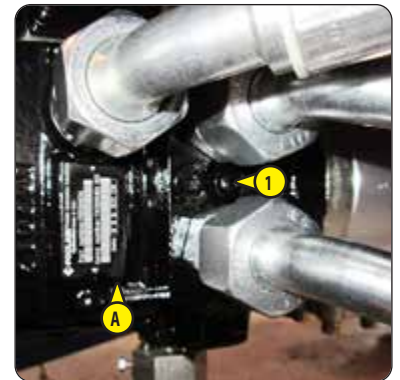

FREEWHEEL AND WINCH

- Attach the winch to the machine's anchoring points, ◀ 2 - DESCRIPTION: STICKERS: ANCHORING POINT
- Bypass the hydrostatic circuit:
 - Open the right-hand chassis cover
 - Locate the hydrostatic pump **A** and the screw **1** between the 2 pipes
 - Loosen the screw **1** by 2 turns counterclockwise with 1 Allen key
 - Close the right-hand chassis cover
- Release the brakes:
 - Locate the brake release device **B** at the front of the machine
 - Press and hold down the button **2**
 - Press the pump button **3** and pull it several times until the button **2** stays down
- Make sure the route is free of any obstruction
- Remove the chocks from the wheels
- Winch the machine slowly
- Chock the wheels when the machine is in the desired position

RESTORE BRAKE FUNCTION

- Pull the button **2**
- Reactivate the hydrostatic circuit:
 - Open the right-hand chassis cover
 - Tighten the screw **1** by 2 turns clockwise with 1 Allen key
 - Close the right-hand chassis cover
- Detach the winch and remove the wheel chocks
- Test the brakes:
 - Start the diesel engine
 - Drive the machine a short distance forward/backward and brake

Result: the brakes should work properly
- Switch the machine off

⚠ IMPORTANT ⚠

The surface of the departure/arrival zone must be closed, level and even.

If the departure/arrival zone is a transport vehicle:

- The transport vehicle must be parked on a level, firm surface.
- The wheels of the transport vehicle must be chocked.

Make sure that the lifting slings are solid enough to take the weight of the machine.

Make sure that the lifting capacity of the crane is sufficient to take the weight of the machine.

The turntable must be locked before lifting the machine,  2-DESCRIPTION: SAFETY COMPONENTS: TURNTABLE LOCKING PIN.

Covers must be closed and locked (if applicable) while the machine is being lifted.

CG = CENTER OF GRAVITY	
X	1095 mm
Y	985 mm
A	560 mm
B	897 mm
TOTAL WEIGHT	4150 kg

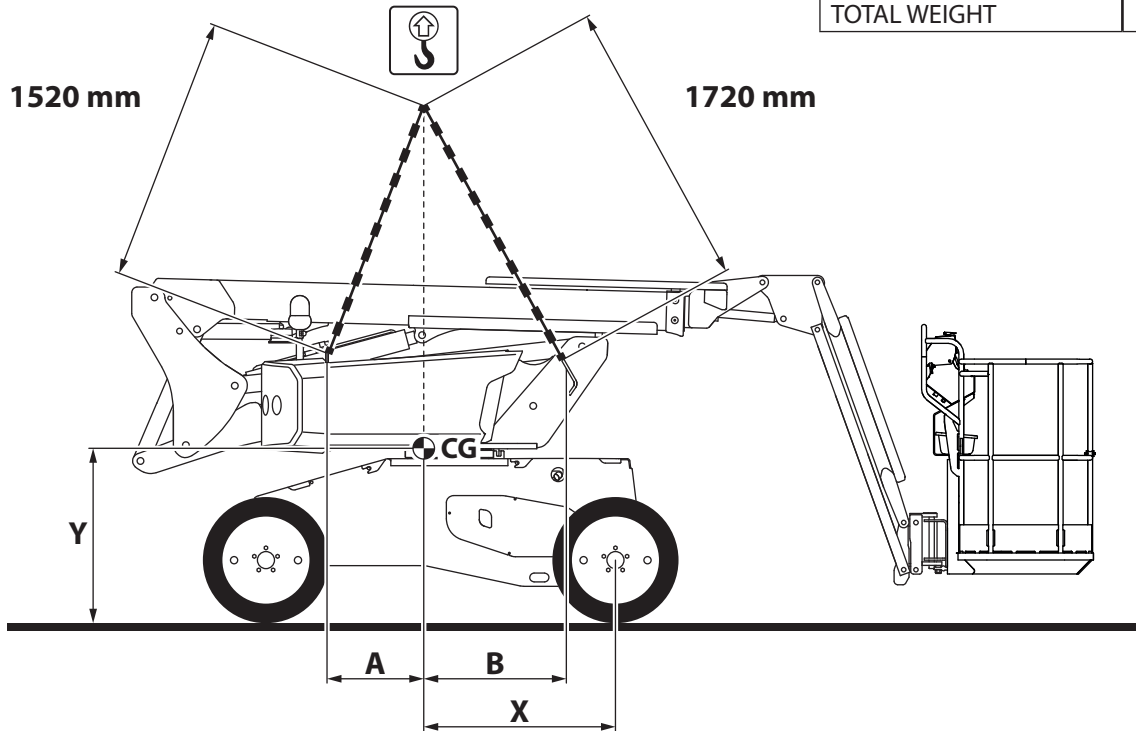

- Mark out a wide safety area around the machine.
- Start the diesel engine.
- Put the machine in transport position. Put the platform in neutral position, OPERATING THE MACHINE: TRANSPORT/WORKING POSITION.
- Fully lower the jib arm.
- Ensure that the turntable is locked, 2 - DESCRIPTION: SAFETY COMPONENTS: TURNTABLE LOCKING PIN
- Switch off the machine. Remove the key.
- Attach lifting slings to the 4 lifting points on the machine, 2 - DESCRIPTION: STICKERS: LIFTING POINT
- Attach the lifting slings at 1 point to the crane lifting hook.
- Slowly lift the crane's lifting hook until the lifting slings are slightly taut.
- If necessary, adjust the lifting slings to prevent damage and keep the machine level.
- Ensure that there is nobody in the safety zone.
- Lift the machine slowly and move it to the arrival zone.
- Slowly lower the machine until the 4 wheels are in contact with the receiving surface.
- Lower the crane's lifting hook until the lifting slings are no longer taut.
- Detach the lifting slings.

NB: 2 - DESCRIPTION: STICKERS: LIFTING