



647776 US (24/09/2025)

MT 733 EASY 75D ST5 S1  
MT 933 EASY 75D ST5 S1

**OPERATOR'S MANUAL**  
*(ORIGINAL MANUAL)*

## IMPORTANT

*Carefully read and understand this instruction manual before using this machine.*

*It contains all information relating to operation, handling and equipment, as well as important recommendations to be followed.*

*This document also contains precautions for use, as well as information on the service and routine maintenance required to ensure the machine's continued reliability and safety of use.*

WHENEVER YOU SEE THIS SYMBOL, IT MEANS:



**NOTE! BE CAREFUL! YOUR SAFETY, THAT OF OTHERS, OR THE SAFETY OF THE MACHINE IS AT RISK.**

- This manual has been produced based on the equipment list and technical characteristics given at the time of its design.
- The machine's equipment level depends on the options chosen and the country of sale.
- Depending on the machine's options and the date of sale, certain equipment or functions described in this manual may not be present on this machine.
- Descriptions and figures are nonbinding.
- MANITOU reserves the right to change its models and their equipment without being required to update this manual.
- The MANITOU network, consisting exclusively of qualified professionals, is available to answer all your questions.
- This manual is an integral part of the machine.
- It is to be kept in its storage location at all times for ease of reference.
- Give this manual to the new owner if the machine is resold.

## CALIFORNIA PROPOSITION 65 WARNINGS

### WARNING

This product can expose you to lead which is known to the State of California to cause cancer and birth defects or other reproductive harm.

For more information go to [www.P65Warnings.ca.gov](http://www.P65Warnings.ca.gov)

### WARNING

Breathing diesel engine exhaust exposes you to chemicals known to the State of California to cause cancer and birth defects or other reproductive harm.

- Always start and operate the engine in a well-ventilated area.
- If in an enclosed area, vent the exhaust to the outside.
- Do not modify or tamper with the exhaust system.
- Do not idle the engine except as necessary.

For more information go to [www.P65Warnings.ca.gov/diesel](http://www.P65Warnings.ca.gov/diesel)

## SILICA DUST HAZARD

Exposure to crystalline silica (found in sand, soil and rocks) has been associated with silicosis, a debilitating and often fatal lung disease. Comply with all applicable rules and regulations for the workplace. Wear approved respiratory protection or use water spray or other means if there is no other way to control the dust.

A Silica rule "29 CFR 1929.1153" by the U.S. Occupational Safety and Health (OSHA) indicates a significant risk of chronic silicosis for workers exposed to inhaled crystalline silica over a working lifetime. Refer to the rule for more information regarding exposure limits and hazard prevention.



**1<sup>st</sup> EDITION**

**28/02/2020**

**UPDATED**

**24/09/2025**

**0-0**

**1-1 – 1-34**

**2-16 – 2-17 ; 2-46**

**3-9 ; 3-10 ; 3-32 ; 3-34**

**4-6 – 4-7 ; 4-11 – 4-12**

*This brochure and all the information contained herein, including drawings, are the intellectual property of Manitou BF and/or its subsidiaries (hereinafter "Manitou Group") and are confidential. Any reproduction, publication or communication to third parties of all or part of the brochure without the express written consent of Manitou Group is strictly prohibited. Any violation will subject you to legal action. The logos and visual identity of the company are the property of Manitou Group and may not be used without express formal authorization. All rights reserved.*

*All trademarks mentioned, whether registered or not, are and shall remain the property of MANITOU BF or its owner respectively.*

*Any reproduction, source code access, decompilation, modification, copy (other than backup copies), correction of errors, transmission or distribution of any software built into Manitou Group machines is strictly prohibited.*

*In the event that the measures above nevertheless prove essential to enable use of the software, in accordance with its destination, or to obtain the information required for interoperability with other software created independently, the user should contact Manitou Group in advance and may, at its sole discretion, take the necessary measures or give access to only the information strictly necessary for interoperability.*

*Any breach of these requirements is likely to constitute a counterfeiting offense subject to legal action by Manitou Group.*

*Connected Manitou Group machines are equipped with boxes that collect technical data on the machines (such as geo-tracking data or data on component operation). This data, which is organized, processed and enhanced by algorithms and expertise proprietary to Manitou Group, constitutes, whether or not in conjunction with other independent elements, a protected database under applicable intellectual property laws and regulations.*

*It is strictly forbidden to have access to all or part of this database and to use the data (including in the event of accidental access) without explicit prior authorization from Manitou Group. In the event that Manitou Group authorizes a Manitou Group machine user to access all or part of this database, Manitou Group, as producer of this database, cedes to the user only a right to personal, non-exclusive, nontransferable use of the database, and only by access to an information technology platform hosted by a server owned or controlled by Manitou Group.*

*In any case, the following are strictly prohibited:*

- any extraction, reproduction, representation, reuse through provision to the public, distribution, transfer, permanent or temporary, on any medium, by any means, and in any form whatsoever, of all or of a qualitatively or quantitatively substantial part of the contents of this database,*
- any extraction, reproduction, representation, reuse through provision to the public, distribution, transfer, repeated or systematic of qualitatively or quantitatively insubstantial parts of the content of the database during operations manifestly exceeding normal use of the database by the user of the machine for his own needs,*
- any use of means to bypass technical protection measures for databases or the software source code embedded in the boxes, in accordance with the applicable intellectual property laws and regulations.*

*The latest applicable version of this document is available upon request.*

*Only the computerized version is managed.*

*MANITOU BF S.A. Public limited company with a board of directors.*

*Head office: 430 rue de l'Aubinière - 44150 Ancenis - France*

*Share capital: €39,548,949*

*Entered in the Nantes Trade and Companies Register under number 857 802 508.*

*Tel.: +33 (0) 2 40 09 10 11*

*www.manitou.com*

**1 - OPERATING AND SAFETY INSTRUCTIONS**

**2 - DESCRIPTION**

**3 - MAINTENANCE**

**4 - ATTACHMENTS**





# ***1 - OPERATING AND SAFETY INSTRUCTIONS***

# 1 - OPERATING AND SAFETY INSTRUCTIONS

## **INSTRUCTIONS TO THE COMPANY MANAGER**

**1-4**

<b>THE SITE</b>	<b>1-4</b>
<b>THE OPERATOR</b>	<b>1-4</b>
<b>THE MACHINE</b>	<b>1-4</b>
A - SUITABILITY OF THE MACHINE FOR THE TASK . . . . .	1-4
B - ADAPTING THE MACHINE TO USUAL ENVIRONMENTAL CONDITIONS . . . . .	1-4
C - MODIFYING THE MACHINE. . . . .	1-5
D - FRENCH ROAD TRAFFIC RULES. . . . .	1-5
E - MACHINE CAB PROTECTION. . . . .	1-5
<b>INSTRUCTIONS</b>	<b>1-6</b>
<b>MAINTENANCE</b>	<b>1-6</b>

## **INSTRUCTIONS FOR THE OPERATOR**

**1-8**

<b>FOREWORD</b>	<b>1-8</b>
<b>GENERAL INSTRUCTIONS</b>	<b>1-8</b>
A – OPERATOR'S MANUAL. . . . .	1-8
B - AUTHORIZATION FOR USE IN FRANCE. . . . .	1-8
C - MAINTENANCE . . . . .	1-8
D - TIRES . . . . .	1-9
E - MODIFYING THE MACHINE. . . . .	1-9
F - LIFTING PEOPLE. . . . .	1-9
<b>OPERATING INSTRUCTIONS UNLADEN AND LADEN</b>	<b>1-10</b>
A - BEFORE STARTING UP THE MACHINE . . . . .	1-10
B - AVAILABLE IN THE DRIVER'S CAB. . . . .	1-10
C - ENVIRONMENT . . . . .	1-10
D - VISIBILITY . . . . .	1-11
E - STARTING THE MACHINE . . . . .	1-12
F - OPERATING THE MACHINE . . . . .	1-12
G - STOPPING THE MACHINE. . . . .	1-14
H - DRIVING THE MACHINE ON THE PUBLIC HIGHWAY. . . . .	1-15
<b>INSTRUCTIONS FOR HANDLING A LOAD</b>	<b>1-18</b>
A - CHOICE OF ATTACHMENTS . . . . .	1-18
B - WEIGHT OF LOAD AND CENTER OF GRAVITY . . . . .	1-18
C - LONGITUDINAL STABILITY INDICATOR. . . . .	1-18
D - TRANSVERSE ATTITUDE OF THE MACHINE. . . . .	1-19
E - PICKING UP A LOAD ON THE GROUND . . . . .	1-19
F - PICKING UP AND PUTTING DOWN A HIGH LOAD ON TIRES . . . . .	1-20
G - PICKING UP AND PUTTING DOWN A HIGH LOAD ON STABILIZERS. . . . .	1-22
H - PICKING UP AND PUTTING DOWN A SUSPENDED LOAD. . . . .	1-24
I - TRAVELING WITH A SUSPENDED LOAD. . . . .	1-24
<b>INSTRUCTIONS FOR USE AS A LOADER</b>	<b>1-25</b>
A - LOADING . . . . .	1-25
B - BACKFILLING. . . . .	1-25
<b>INSTRUCTIONS FOR USING THE MOBILE ELEVATING WORK PLATFORM</b>	<b>1-26</b>
A - AUTHORIZATION FOR USE . . . . .	1-26
B - SUITABILITY OF THE PLATFORM FOR THE JOB . . . . .	1-26
C - PROVIDED ON THE PLATFORM . . . . .	1-26
D - USING THE PLATFORM. . . . .	1-27
E - ENVIRONMENT . . . . .	1-28
F - MAINTENANCE . . . . .	1-28
<b>INSTRUCTIONS FOR USING THE RADIO-CONTROL</b>	<b>1-29</b>
HOW TO USE THE RADIO-CONTROL. . . . .	1-29
PROTECTIVE DEVICES. . . . .	1-29

**MACHINE MAINTENANCE INSTRUCTIONS** **1-30**

---

**GENERAL INSTRUCTIONS** **1-30**

**PLACING THE JIB SAFETY WEDGE** **1-30**

FITTING THE WEDGE. . . . . 1-30

REMOVING THE WEDGE . . . . . 1-30

FITTING THE WEDGE. . . . . 1-30

REMOVING THE WEDGE . . . . . 1-30

**MAINTENANCE** **1-31**

MAINTENANCE LOGBOOK . . . . . 1-31

**LUBRICANT AND FUEL LEVELS** **1-31**

**HYDRAULICS** **1-31**

**ELECTRICITY** **1-31**

**WELDING ON THE MACHINE** **1-31**

**WASHING THE MACHINE** **1-32**

**TRANSPORTING THE MACHINE** **1-32**

**PROLONGED MACHINE SHUTDOWN** **1-32**

---

**INTRODUCTION** **1-32**

**PREPARATION OF THE MACHINE** **1-32**

**DEF (Diesel Exhaust Fluid) TANK** **1-32**

**PROTECTING THE ENGINE** **1-33**

**MACHINE PROTECTION** **1-33**

**RETURNING THE MACHINE TO SERVICE** **1-33**

**DISPOSING OF THE MACHINE** **1-34**

---

**RECYCLING OF MATERIALS** **1-34**

METALS. . . . . 1-34

PLASTICS. . . . . 1-34

RUBBER. . . . . 1-34

GLASS. . . . . 1-34

**ENVIRONMENTAL PROTECTION** **1-34**

WORN OR DAMAGED PARTS . . . . . 1-34

USED OIL. . . . . 1-34

USED BATTERIES . . . . . 1-34

# INSTRUCTIONS TO THE COMPANY MANAGER

## THE SITE

Proper management of the machine's area of travel will reduce the risk of accidents:

- ground not unnecessarily uneven or obstructed,
- no excessive slopes,
- pedestrian traffic controlled, etc.

## THE OPERATOR

- Only qualified, authorized personnel can use the machine. This authorization is given in writing by the appropriate person in the establishment where the machine is to be used and must be carried permanently by the operator.

### **⚠ IMPORTANT ⚠**

*Experience has shown that there are a number of inappropriate ways in which the machine might be operated. Such foreseeable misuse, of which the main examples are listed below, are strictly forbidden.*

*- The foreseeable abnormal behavior resulting from ordinary negligence, but not from any intentional misuse of the equipment.*

*- The reflex reactions of a person in the event of a malfunction, incident, fault, etc. during operation of the machine.*

*- Behavior resulting from application of the "principle of least effort" when performing a task.*

*- For certain machines, the foreseeable behavior of such persons as: apprentices, teenagers, handicapped persons, trainees tempted to drive a machine, operators tempted to operate a machine to win a bet, in competition or for their own personal experience.*

*The person in charge of the equipment must take these criteria into account when assessing whether or not a person will make a suitable driver.*

## THE MACHINE

### A - SUITABILITY OF THE MACHINE FOR THE TASK

- MANITOU has ensured that this machine is suitable for use under the standard operating conditions defined in this operator's manual, with a **STATIC TEST COEFFICIENT OF 1.25** and a **DYNAMIC TEST COEFFICIENT OF 1**, as specified in harmonized standard **EN 1459** for variable reach machines.
- Before commissioning, the facility manager must make sure that the machine is appropriate for the work to be done, and perform certain tests (in accordance with applicable legislation).

### B - ADAPTING THE MACHINE TO USUAL ENVIRONMENTAL CONDITIONS

#### **⚠ IMPORTANT ⚠**

*Lubricants are filled in the factory for average climatic use, i.e.: -15 °C (4,9 °F) to +35 °C (95 °F).*

*For operation under more severe climatic conditions, before starting up, drain all circuits then fill using lubricants suitable for the ambient temperatures.*

*The same applies to the coolant.*

#### **⚠ IMPORTANT ⚠**

*The machines are designed for outdoor use under normal atmospheric conditions and indoor use in suitably aerated and ventilated premises. It is prohibited to operate the machine in areas which presents a risk of fire or which are potentially explosive (e.g. refineries, fuel or gas depots, stores of flammable products, etc.).*

*Specialized equipment is available when operating in these areas (ask your dealer for information).*

- Our machines are designed to be used within a temperature range of -18 °C (-0.4°F) to +43 °C (109.4°F).
- In addition to the standard equipment fitted on your machine, many options are available, such as: road lighting, stop lights, rotating beacon light, reverse lights, front worklight, rear worklight, lifting structure worklight, etc. (depending on machine model).
- The operator must take into account the operating conditions to specify the machine's signaling and lighting equipment. Consult your dealer.
- Take into account the climatic and atmospheric conditions of the operation site. Consult your dealer for the suitability of lubricants and frost protection.
- Take into account the fire risk associated with use in dusty and flammable conditions (e.g. straw, flour, sawdust, organic waste, etc.).
- A machine operating in an area without fire extinguishing equipment must be equipped with an individual extinguisher. Solutions exist, consult your dealer.

Our machines comply with Directive 2014/30/EU (2015/208/EU for our type-approved "TRACTOR" machines) concerning electromagnetic compatibility (EMC), (UK : Electromagnetic Compatibility Regulations 2016) and with the corresponding harmonized standard EN 12895. Their correct operation is no longer guaranteed if they are used within areas in which the electromagnetic fields exceed the limit specified by this standard (20 V/m).

- Directive 2002/44/EC requires company managers to not expose their employees to excessive vibration doses. There is no recognized code of measurement for comparing the machines of different manufacturers. The actual doses received cannot therefore be measured under actual operating conditions at the user's premises.
- The following are some tips for minimizing these vibration doses:
  - Select the most suitable machine and attachment for the intended use.
  - Adapt the seat adjustment to the operator's weight (**depending on machine model**) and maintain it in good condition, as well as the cab suspensions. Inflate the tires in accordance with recommendations.
  - The seat is an essential way of reducing the vibrations transmitted to the operator. In the event of seat replacement, please contact MANITOU.
  - Ensure that the operators adapt their operating speed to suit the conditions on site.
  - As far as possible, arrange the site in such a way as to provide a flat running surface and remove obstacles and harmful potholes.

## C - MODIFYING THE MACHINE



**Modifying the structure and settings of the various components of your machine (hydraulic pressure, taring of limiters, engine speed, sensors, addition of extra equipment, addition of counterweights, unapproved and unauthorized attachments, alarm systems, etc.) yourself is strictly prohibited. In this case, the manufacturer cannot be held responsible.**

## D - FRENCH ROAD TRAFFIC RULES

(or see current legislation in other countries)

- Only one EC declaration of conformity is issued. It must be kept in a safe place.
- The road traffic rules for the machines are subject to the provisions of the highway code, according to the following categories:
  - Construction machinery (MT range): public works vehicle not predominantly for use on roads (point 6.9 of Article R.311-1 of the French Highway Code). The machine must have a 25 disc displayed on the rear of the machine and an operating license plate.
  - Non-type-approved "Tractor" machinery for agricultural work: (point 6.2 of Article R.311-1 of the French Highway Code). The machine must be fitted with an operating license plate.
  - Type-approved "Tractor" machinery for agricultural work: Agricultural tractor type T1a (point 5.1.1 of Article R.311-1 of the French Highway Code). The machine must be licensed.

## SPECIAL INSTRUCTIONS APPLICABLE TO TYPE-APPROVED "TRACTOR" MACHINES

- All approved machines are supplied with a "Tractor" certificate of compliance with Regulation 167/2013, to be retained by the owner, and a page of administrative details together with a CNIT number (national type approval code) for registration at the prefecture.
- The owner of the machine is responsible for carrying out the necessary procedures for obtaining the vehicle registration document within the time limit defined by the regulations.
- The operator must hold a category B driver's license, unless granted an exemption.
- The machine must be driven on the public highway in accordance with the instructions given in the manual supplied with the machine (Gross weight, Gross combination weight, towing load, axle loads, maximum speeds, etc. according to the type/version). The operator must be in possession of the machine's registration document.



**When towing a trailer or agricultural equipment, the traveling speed of the machine is limited to 25 km/h.**

**In this case, a "25" disc must be affixed to the rear of the convoy.**

## E - MACHINE CAB PROTECTION

- All machines comply with standard ISO 3471 Roll-over Protective Structures (ROPS)
- All machines comply with standard ISO 3449 Falling-Object Protective Structures (FOPS) (Level I or II) (← 2 - DESCRIPTION OF STICKERS AND PLATES)
- The windows used on our machines comply with standard ECE-R43 Operator Protective Structures (OPS).
- Approved "TRACTOR" machines also comply with the regulations:
  - (appendix 1322/2014-OCDE Code 4).
  - (appendix 1322/2014-OCDE Code 10).



**Structural damage or overturning, a modification, changes or a poorly executed repair can reduce the protective efficiency of the cab, canceling its compliance.**

**Do not perform welding or drilling on the cab structure.**

**Consult your dealer to determine the limits of this structure without canceling its compliance.**

## **INSTRUCTIONS**

---

- The operator's manual must always be in good condition, in the language of the operator and placed in the storage compartment provided.
- The operator's manual and any plates or stickers which are no longer legible or are damaged, must be replaced immediately.

## **MAINTENANCE**

---

**⚠ IMPORTANT ⚠**

*Refer to chapter: MACHINE MAINTENANCE INSTRUCTIONS.*

**⚠ IMPORTANT ⚠**

*Your machine must be periodically inspected to ensure its continued compliance.*

*The frequency of this inspection is defined by the legislation in force in the country in which the machine is used.*

- Maintenance or repairs other than those detailed in Part: 3 - MAINTENANCE must be carried out by qualified personnel (consult your dealer) and in the necessary safety conditions to preserve the health of the operator and any third party.
- Example for France "The manager in charge of the establishment using a machine must open and maintain a maintenance log for each machine (order of March 2, 2004) and undergo a general periodic inspection every 6 months (order of March 1, 2004)".



# INSTRUCTIONS FOR THE OPERATOR

## FOREWORD

### **⚠ IMPORTANT ⚠**

*The risk of accident while using, servicing or repairing this machine can be reduced if you follow the safety instructions and preventive measures detailed in this instruction manual.*

*Failure to respect the safety and operating instructions, or the instructions for repairing or servicing your machine may lead to serious, even fatal accidents.*

### **⚠ IMPORTANT ⚠**

*In order to reduce or prevent any danger with a MANITOU-approved attachment, follow the instructions in paragraph: 4 - ADAPTABLE ATTACHMENTS AVAILABLE ON THE RANGE: INTRODUCTION.*

- Only the operations and maneuvers described in these operator's manual must be performed. The manufacturer cannot predict all possible risky situations. Consequently, the safety instructions given in the operator's manual and on the machine itself are not exhaustive.
- At all times, as an operator, you must envisage, within reason, the possible risk to yourself, to others or to the machine when you use it.
- The operator is responsible for the machine in all circumstances, regardless of whether he is present in the driver's cab.

## GENERAL INSTRUCTIONS

### A – OPERATOR'S MANUAL

#### **⚠ IMPORTANT ⚠**

*Carefully read and understand this operator's manual before operating this machine.*

- The operator's manual must always be in good condition, in the language of the operator and placed in the storage compartment provided.
- Any operations or maneuvers not described in the operator's manual are proscribed.
- Follow the safety advice and the instructions described on the machine's stickers.
- Familiarize yourself with the machine on the ground where it will be operated.
- You must replace the instruction manual, as well as any plates or stickers, if they are no longer legible or are missing or damaged.

### B - AUTHORIZATION FOR USE IN FRANCE

*(or see current legislation in other countries).*

- Only qualified, authorized personnel can use the machine. This authorization is given in writing by the appropriate person in the establishment where the machine is to be used and must be carried permanently by the operator.
- The operator is not empowered to authorize the driving of the machine by another person.

### C - MAINTENANCE

- If the operator sees that the machine is not in good working order or does not comply with the safety instructions, he must inform his manager of this immediately.
- The operator is prohibited from carrying out any repairs or adjustments himself, unless he has been trained for this purpose. He must keep the machine properly cleaned if this is his responsibility.
- The operator must carry out the daily maintenance (↩ 3 - MAINTENANCE) before using the machine in his place of work.
- The operator is responsible for deciding and adjusting the frequency and type of the cleaning needed to prevent the risk of fire ensuing from the build-up of flammable material(s). The operator should pay special attention to all the areas of the machine where these high-risk materials are likely to accumulate (e.g. engine compartment, under the lifting structure, above the axles, inside the chassis, etc.).

## D - TIRES

### ⚠ IMPORTANT ⚠

*Do not use the machine if the wheels are damaged or excessively worn, because this could put your own safety or that of others at risk, or cause damage to the machine.*

- The operator must ensure tires are suitable for the nature of the ground (see contact surface with the ground for the tires in the chapter: 2 - DESCRIPTION: TIRES). Optional solutions are available, please consult your dealer.
  - SAND tires.
  - FARM tires.
  - Snow chains.
- The machine's four tires must be the same brand, the same dimensions, the same structure (radial or diagonal) and the same usage category (normal, snow or special), and must have the same degree of tread wear.
- In the event of tire replacement, use tires authorized by MANITOU that are the same type and dimensions. Using different tires voids the machine's type approval and you may be liable.
- If you are replacing just one of the machine's tires (e.g. because it is damaged), we recommend choosing a tire with the same degree of wear as the remaining tires so as not to damage the transmission's kinematic chain.

### ⚠ IMPORTANT ⚠

*Do not use the machine if the tires are damaged or excessively worn, because this could put your own safety or that of others at risk, or cause damage to the machine itself.*

*The fitting of foam inflated tires is prohibited and is not guaranteed by the manufacturer unless with prior authorization.*

## E - MODIFYING THE MACHINE

- ⚠ INSTRUCTIONS TO THE COMPANY MANAGER: ⚠ C - MODIFYING THE MACHINE.

## F - LIFTING PEOPLE

- The use of working equipment and load lifting attachments to lift people is:
  - either forbidden
  - or authorized exceptionally and under certain conditions (⚠ regulations in force in the country in which the machine is used).
- The pictogram posted at the operator station reminds you that:
  - Left-hand column
    - It is forbidden to lift people, with any kind of attachment, using a non PLATFORM-fitted machine.
  - Right-hand column
    - With a PLATFORM-fitted machine, people can only be lifted using platforms designed by MANITOU for this purpose.
- MANITOU sells equipment specifically designed for lifting people (OPTION PLATFORM-fitted machine; contact your dealer).

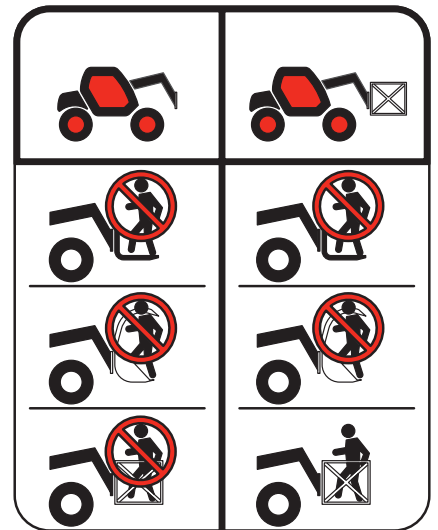

**A - BEFORE STARTING UP THE MACHINE**

- Perform the daily maintenance operations (< 3 - MAINTENANCE).
- Make sure that the driver's cab is clean, particularly the floor and floor mat. Check that no movable object may hinder the operation of the machine.
- Make sure the lights, turn signals and windshield wipers are working properly.
- Make sure the rear-view mirrors are in good condition, clean and properly adjusted.
- Make sure the horn works.

**B - AVAILABLE IN THE DRIVER'S CAB**

- Whatever his experience, the operator is advised to familiarize himself with the position and operation of all the controls and instruments before operating the machine.
- Wear clothes suitable for driving the machine, avoid loose clothing.
- Make sure you have the appropriate protective equipment for the task to be performed.
- Prolonged exposure to high noise levels may cause hearing problems. It is recommended to wear ear muffs to protect against excessive noise.
- Always face the driver's cab access when getting in and out of the lift truck and use the handle(s) provided for this purpose. Do not jump out of the machine.
- Remain alert at all times when using the machine. Do not listen to the radio or music using headphones or earphones.
- Never operate the lift truck when hands or feet are wet or soiled with greasy substances.
- For increased comfort, adjust the seat to your requirements and adopt the correct position in the driver's cab.



*Under no circumstances must the seat be adjusted while the machine is moving.*

- The operator must always be in his normal position in the driver's cab: Arms and legs, and generally any part of the body, should be kept inside the driver's cab of the machine.
- The safety belt must be worn and adjusted to the operator's size.
- The control units must never be used for any other than their intended purposes (e.g. Climbing onto or down from the machine, coat hanger, etc.).
- If the control components are fitted with a forced operation (lever lock) device, it is forbidden to leave the cab without first putting these controls in neutral.
- It is prohibited to carry passengers either on the machine or in the cab.

**C - ENVIRONMENT**

- Comply with site safety regulations.
- If you have to use the machine in a dark area or work at night, make sure it is equipped with work lights.
- During handling operations, make sure that no one is in the way of the machine and its load.
- Do not allow anybody to come near the working area of the machine or pass beneath an elevated load.
- The maximum slope on which the machine can be used in relation to the capacity of the brake is 20%.
- When using the lift truck on a transverse slope, before lifting the lifting structures, observe the instructions given in the paragraph: INSTRUCTIONS FOR HANDLING A LOAD: D - TRANSVERSE ATTITUDE OF THE MACHINE.
- Traveling on a longitudinal slope:
  - Drive and brake gently.

- Moving without load: Forks or attachment facing downhill.

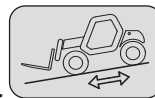

- Moving with load: Forks or attachment facing uphill.

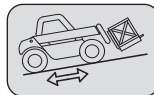

- Take into account the machine's dimensions and its load before trying to negotiate a narrow or low passageway.
- Never move onto a load bridge without having first checked:
  - That it is suitably positioned and made fast.
  - That the unit to which it is connected (wagon, truck, etc.) will not shift.
  - That this bridge is prescribed for the total weight of the machine, laden or unladen.
  - That this bridge is prescribed for the size of the machine.

- Never move onto a foot bridge, floor or freight lift, without being certain that they are suitable for the weight and size of the machine, laden or otherwise, and without having checked that they are in sound working order.
- Be careful in the area of loading bays, trenches, scaffolding, soft ground and manholes.
- Make sure the ground is stable and firm under the wheels and/or stabilizers before lifting or removing the load. If necessary, add appropriate wedging under the stabilizers.
- Make sure that the scaffolding, loading platform, pilings or ground is capable of bearing the load.
- Never stack loads on uneven ground, they may tip over.

**⚠ IMPORTANT ⚠**

*If the load or the attachment must remain above a structure for a prolonged period of time, there is the risk that it will bear on the structure as the lifting structure descends due to cooling of the oil in the cylinders.*

*To eliminate this risk:*

*- Regularly check the distance between the load or the attachment and the structure and readjust this if necessary.*

*- If possible use the machine at an oil temperature as close as possible to ambient temperature.*

- In the case of work near to overhead lines, ensure that the safety distance is sufficient between the machine's working area and the overhead line.

**⚠ IMPORTANT ⚠**

*Do not operate this machine during thunderstorms, snowstorms, periods of frost, or in hazardous weather conditions.*

**⚠ IMPORTANT ⚠**

*You must consult your local electrical supplier.*

*You could be electrocuted or seriously injured if you operate or park the machine too close to power lines.*

*In the event of high winds, do not carry out handling work that jeopardizes the stability of the machine and its load, particularly if the load catches the wind badly.*

- Prevent the fire risk associated with use in dusty and flammable conditions (e.g. straw, flour, sawdust, organic waste, etc.).

## **D - VISIBILITY**

- The safety of people within the machine's working area, as well as that of the machine itself and the operator, are dependent on good operator visibility of the machine's immediate surroundings in all situations and at all times.
- This machine has been designed to allow good operator visibility (direct or indirect by means of rear-view mirrors) of the immediate surroundings of the machine while driving with no load and with the boom in the transport position.
- Special precautions must be taken if the size of the load restricts visibility towards the front:
  - moving in reverse,
  - site layout,
  - assisted by a person directing the operation (while standing outside the machine's area of travel), making sure to keep this person clearly in view at all times,
  - in any case, avoid reversing over long distances.
- Certain special accessories may require the machine to travel with the boom in the raised position. In such cases, visibility on the right hand side is restricted, and special precautions must be taken:
  - site layout,
  - assisted by a person directing the operation (while standing outside the machine's area of travel).
  - replacement of a suspended load by a load on a pallet.
- If visibility of your road is inadequate, ask someone to assist by directing the operation (while standing outside the machine's area of travel), making sure to keep this person clearly in view at all times.
- Keep all components affecting visibility in a clean, properly adjusted state and in good working order (e.g. windshields, windows, windshield wipers, windshield washers, driving lights and worklights, rear-view mirrors).

## E - STARTING THE MACHINE

### SAFETY INSTRUCTIONS

#### **⚠ IMPORTANT ⚠**

*The machine must only be started up or maneuvered when the operator is sitting in the driver's cab with seat belt fastened and adjusted.*

- Never try to start the machine by pushing or towing it. Such an operation may cause severe damage to the transmission. If necessary, towing requires the transmission to be put in neutral (↩ 3 - MAINTENANCE).
- If using an emergency battery for start-up, use a battery with the same characteristics and respect battery polarity when connecting it. Connect at first the positive terminals before the negative terminals.

#### **⚠ IMPORTANT ⚠**

*Failure to respect polarity between batteries can cause serious damage to the electrical circuit.*

*The electrolyte in the battery may produce an explosive gas. Avoid flames and generation of sparks close to the batteries.*

*Never disconnect a battery while it is in charge.*

### INSTRUCTIONS

- Check the closing and locking of the hood(s).
- Check that the cab door is closed.
- Firmly press and hold down the brake pedal.
- Turn the ignition key to position (I) to switch on the machine and the engine preheat system.
- Check that the forward/reverse selector is in neutral, and that the manual parking brake is on.
- Check the fuel level on the dashboard gauge.
- Check the DEF (diesel exhaust fluid) level on the dashboard gauge. (depending on machine model)
- Turn the ignition key to position (III) for no longer than 15 seconds. The engine should then start. Release the ignition key and let the engine run at idling speed.
- Preheat the engine between each start attempt.
- Make sure all the signal lights on the control instrument panel are off.
- Do not use a machine that is non-compliant.
- Check all control instruments when the engine is warm and at regular intervals during use, so as to quickly detect any faults and to be able to correct them without any delay.
- If an instrument does not show the correct display, stop the engine and immediately carry out the necessary operations.

## F - OPERATING THE MACHINE

### SAFETY INSTRUCTIONS

#### **⚠ IMPORTANT ⚠**

*We would like to draw the operators' attention to the risks involved in using the machine, in particular:*

*- Risk of losing control.*

*- Risk of loss of lateral and frontal stability of the machine.*

*The operator must remain in control of the machine.*

*In the event of the machine overturning, do not try to leave the cab during the incident.*

**YOUR BEST PROTECTION IS TO STAY FASTENED IN THE CAB.**

- Observe the company's traffic regulations or, by default, the public highway code.
- Do not carry out operations which exceed the capacities of your machine or attachment.
- Always drive the machine with the forks or attachment in the transport position, i.e., at 300 mm (11.81 in) from the ground, the boom retracted and the forks carriage sloping backwards.
- Only carry loads which are balanced and properly anchored to avoid any risk of a load falling off.
- Ensure that pallets, cases, etc. are in good order and suitable for the load to be lifted.
- Familiarize yourself with the machine on the terrain where it will be used.
- Ensure that the brakes are working properly.
- The loaded machine must not travel at speeds in excess of 12 km/h (7.46 mph).
- Drive smoothly at an appropriate speed for the operating conditions (land configuration, load on the machine).
- Do not use the hydraulic boom controls when the machine is moving.
- Never change the steering mode whilst driving.
- Ensure that visibility is adequate.
- Do not maneuver the machine with the boom in the raised position unless under exceptional circumstances and then with extreme caution, at very low speed and using gentle braking.
- Take bends slowly.

- In all circumstances make sure you are in control of your speed.
- On damp, slippery or uneven terrain, drive slowly.
- Brake gently, never abruptly.
- Only use the machine's forward/reverse selector from a stationary position and never do so abruptly.
- Do not drive with your foot on the brake pedal.
- Always remember that hydrostatic type steering is extremely sensitive to movement of the steering wheel, so turn it gently and not jerkily.
- Never leave the engine on when the lift truck is unattended.
- Do not leave the cab when the machine has a raised load.
- Look where you are going and always make sure you have good visibility along the route.
- Use the rear-view mirrors frequently.
- Drive around obstacles.
- Never drive on the edge of a ditch or steep slope.
- It is dangerous to use two machines simultaneously to handle heavy or bulky loads, since this operation requires particular precautions to be taken. It must only be used exceptionally and after risk analysis.
- The ignition switch has an emergency stop mechanism in case of an operating anomaly occurring in the case of machines not fitted with a punch-operated cut-out.

## INSTRUCTIONS

- Always drive the machine with the forks or attachment in the transport position, i.e., 300 mm from the ground, the telescopic arm retracted and the forks carriage sloping backward.
- For machines with gearboxes, use the recommended gear (↩ 2 - DESCRIPTION: INSTRUMENTS AND CONTROLS).
- Select the steering mode appropriate for the use and/or working conditions (↩ 2 - DESCRIPTION: INSTRUMENTS AND CONTROLS) (depending on machine model).
- Deactivate the parking brake.
- Shift the forward/reverse selector to the selected direction of travel and accelerate gradually until the machine moves off.

### **⚠ IMPORTANT ⚠**

***Starting and moving the machine on a slope may be a real hazard.***

***If the machine is parked or stopped, adhere scrupulously to the following instructions for moving it:***

***- Press the brake pedal.***

***- Release the parking brake.***

***- Engage the appropriate gear. (depending on machine model)***

***- Select forward or reverse direction.***

***- Ensure that there is no one or anything impeding the movement of the machine.***

***- Release the brake pedal and accelerate the engine.***

***The use of the machine loaded or with a trailer increases the risk. In this case, remain extremely vigilant.***

***Each braking system operates independently.***

***In an emergency, use the brake pedal and/or the manual parking brake to immobilize the machine.***

***With the engine off, release the manual parking brake only after restarting the engine and making sure that the brake pedal is functional.***

## **G - STOPPING THE MACHINE**

### **SAFETY INSTRUCTIONS**

- Never leave the ignition key in the machine during the operator's absence.
- When the machine is stationary, or if the operator has to leave his cab (even for a moment), place the forks or attachment on the ground, apply the parking brake and place the forward/reverse selector in neutral.
- Make sure that the machine is not stopped in any position that will interfere with the traffic flow and at less than one meter from the track of a railway.
- In the event of prolonged parking on a site, protect the machine from bad weather, particularly from frost (check the level of antifreeze), and close and lock all the machine accesses (doors, windows, cowls, etc.).

### **INSTRUCTIONS**

- Park the machine on level ground.
- When parking on slopes of less than 15%, position the machine perpendicular to the slope.
- The slope must not exceed 15%.
- Press and hold the brake pedal.
- Set the forward/reverse selector to neutral.
- Activate the parking brake.
- Release the brake pedal.
- The machine must be stationary before leaving the driver's cab.
- Fully retract the telescopic arm.
- Lower the forks or attachment to rest on the ground.
- When using an attachment with a grab or jaws, or a bucket with hydraulic opening, close the attachment fully.
- Before stopping the machine after intensive work, leave the engine idling for a few moments to allow the coolant and oil to lower the temperature of the engine and transmission. Do not forget this precaution, in the event of frequent stops or warm stalling of the engine, or else the temperature of certain parts will rise significantly due to the stopping of the cooling system, with the risk of badly damaging such parts.
- Stop the engine with the ignition switch and remove the key.
- Lock all the openings to the machine (doors, windows, cowls, etc.).
- Turn the battery cut-off to the "OFF" position in accordance with the recommendations (↩ 2 - DESCRIPTION).

## H - DRIVING THE MACHINE ON THE PUBLIC HIGHWAY

(or see current legislation in other countries)

### FRENCH ROAD TRAFFIC RULES

- The driving of non-type-approved "Tractor" machines on the public highway is subject to the provisions of the French Highway Code relating to special machines, defined in Article R.311-1 of the French Highway Code, in category B of the Equipment Order of November 20, 1969, which determines the procedures applicable to special machines. The machine must be fitted with an operating license plate.
- The driving of type-approved "Tractor" machines on the public highway is subject to the provisions of the French Highway Code relating to agricultural tractors, defined in Article R.311-1 of the French Highway Code. The machine must be licensed.
- The machine must be driven on the public highway in accordance with the instructions given in the manual supplied with the machine (Gross weight, Gross combination weight, towing load, axle loads, maximum speeds, etc. according to the type/version). The operator must be in possession of the machine's registration document.
- The operator must hold an HGV license, unless granted an exemption.
- When towing a trailer or agricultural equipment, the travel speed of the machine is limited to 25 km/h. In this case, a "25" disc must be affixed to the rear of the convoy.

### GERMAN ROAD TRAFFIC RULES

#### **⚠ IMPORTANT ⚠**

*For machines with the "Allgemeine Betriebserlaubnis" (general operating permit or ABE, in accordance with Article 20 of the StVZO "Straßenverkehrs-Zulassungsordnung"), follow the instructions below:*

- Disconnect the reversing sound alarm before using a machine with a general operating permit (ABE) on the public highway.

#### **⚠ IMPORTANT ⚠**

*Always reconnect the sound alarm before handling on private roads.*

- Before you use the machine for handling operations on private roads:
  - Make sure that the machine's reversing sound alarm is connected and working properly.
  - Perform a functional test by putting the machine into reverse gear.
  - The audible alarm sounds.
  - Do not use the machine if the audible alarm is not working. Check the audible alarm's connection and repeat the test. Consult your dealer if the problem persists.

### SAFETY INSTRUCTIONS

- Operators driving on the public highway must comply with current highway code legislation.
- The machine must comply with current road legislation. If necessary, there are optional solutions. Contact your dealer.

### INSTRUCTIONS

- Make sure the revolving light is in place, switch it on and verify its operation.
- Make sure the lights, turn signals and windshield wipers are working properly.
- Check the cleanliness of the machine's mudguards.
- Check the general cleanliness of the machine before driving on public roads.
- Switch off the worklights if the machine is fitted with them.
- Select the steering mode "HIGHWAY TRAFFIC" (↩ 2 - DESCRIPTION: INSTRUMENTS AND CONTROLS) (depending on machine model).
- Fully retract the telescopic arm and set the attachment approximately 300 mm (11.81 in) off the ground.
- Put the frame leveling in the central position, i.e., the transverse axis of the axles parallel to the frame (depending on the machine model).
- Fully raise the stabilizers and turn the shoes inwards (depending on the machine model).

#### **⚠ IMPORTANT ⚠**

*Never coast in neutral (forward/reverse selector or gear lever in neutral or transmission cut-off button pressed) to preserve the machine's engine brake.*

*Failure to observe this instruction on a slope will lead to excessive speed, which may make the machine uncontrollable (steering, brakes) and cause serious mechanical damage.*

#### DRIVING THE MACHINE WITH A FRONT-MOUNTED ATTACHMENT

- You must comply with current regulations in your country, covering the possibility of driving on the public highway with a front-mounted attachment on your machine.
- If road legislation in your country authorizes circulation with a front-mounted attachment, you must at least:
  - Protect and report any sharp and/or dangerous edges on the attachment (↩ 4 - ADAPTABLE ATTACHMENTS AVAILABLE ON THE RANGE).
  - The attachment must not be loaded.
  - Make sure that the attachment does not mask the lighting range of the forward lights.
  - Make sure that current legislation in your country does not require other obligations.

#### OPERATING THE MACHINE WITH A TRAILER

- For using a trailer, observe the regulations in force in your country (maximum travel speed, braking, maximum weight of trailer, etc.).
- Do not forget to connect the trailer's electrical equipment to that of the machine.
- The trailer's braking system must comply with current legislation.
- If pulling a trailer with assisted braking, the tractor machine must be equipped with a trailer braking mechanism. In this case, do not forget to connect the trailer braking equipment to that of the machine.
- The vertical force on the towing hook must not exceed the maximum authorized by the manufacturer (consult the manufacturer's plate on your machine).
- The authorized gross vehicle weight must not exceed the maximum weight authorized by the manufacturer (↩ 2 - DESCRIPTION: SPECIFICATIONS).

**IF NECESSARY, CONSULT YOUR DEALER.**



## INSTRUCTIONS FOR HANDLING A LOAD

### A - CHOICE OF ATTACHMENTS

- Only attachments approved and authorized by MANITOU can be used on its machines.
- Make sure the attachment is suitable for the work to be done (↖ 4 - ADAPTABLE ATTACHMENTS AS OPTIONS ON THE RANGE).
- If the machine is equipped with the single sideshift attachment OPTION (TSDL), use only the authorized attachments (↖ 4 - ADAPTABLE ATTACHMENTS AS OPTIONS ON THE RANGE).
- Make sure the attachment is correctly installed and locked onto the machine carriage.
- Make sure that your machine attachments are working properly.
- Comply with the load chart limits for the machine for the attachment used.
- Do not exceed the rated capacity of the attachment.
- Never lift a slung load without the attachment provided for the purpose, as there is a risk of the sling slipping (↖ INSTRUCTIONS FOR HANDLING A LOAD: H - PICKING UP AND PUTTING DOWN A SUSPENDED LOAD).
- Do not handle loads suspended by straps directly on the forks (e.g.:big bags), as there is a risk of shearing on sharp edges. Use an attachment designed for this purpose.

### B - WEIGHT OF LOAD AND CENTER OF GRAVITY

- Before picking up a load, you must know its weight and its center of gravity.
- The longitudinal position of the center of gravity in relation to the heel of the forks (Fig. B1) is defined on the load chart for your machine (↖ 2 - DESCRIPTION: DIMENSIONS AND LOAD CHARTS). For loads with center of gravity exceeding this distance, contact your dealer.
- For irregular loads, determine the transverse center of gravity before any handling (fig. B2) and set it in the longitudinal axis of the machine.

#### ⚠ IMPORTANT ⚠

*It is forbidden to handle a load heavier than the effective capacity defined on the machine load chart.*

*For loads with a moving center of gravity (e.g. liquids), take account of the variations in the center of gravity in order to determine the load to be handled and be extra vigilant and careful to limit these variations as far as possible.*



### C - LONGITUDINAL STABILITY INDICATOR

#### ⚠ IMPORTANT ⚠

*Always watch this device during handling operations.*

- Letters and angle indicator (fig. C1) allow to read and respect load capacities of the lifttruck according to the load chart (↖ 2 - DESCRIPTION: LOAD CHART).
- When the device is in limit stability, it is forbidden to perform so-called «AGGRAVATING» movements, these being:
  - A - Extending the boom.
  - B - Lowering the boom.
- Perform movements to relieve aggravation in the following order (fig. C2): if necessary, raise the boom (1), retract the boom as far as possible (2) and lower the boom (3) to release the load.

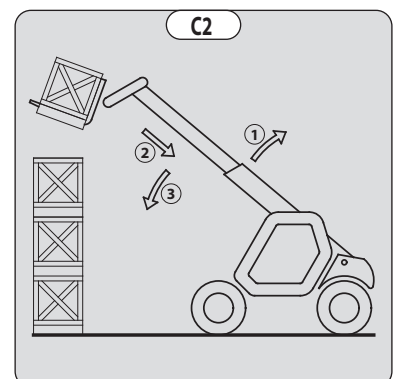
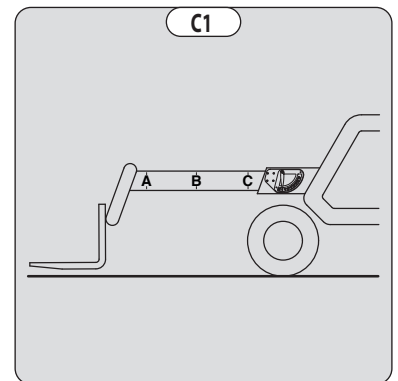

## D - TRANSVERSE ATTITUDE OF THE MACHINE

Depending on machine model

The transverse attitude is the transverse slope of the frame with respect to the horizontal. Raising the boom reduces the machine's lateral stability. The machine's transverse attitude must be set with the boom in the down position as follows:

### 1 - MACHINE WITHOUT FRAME LEVELING USED ON TIRES

- Position the machine so that the bubble in the level is between the two lines (↖ 2 - DESCRIPTION: INSTRUMENTS AND CONTROLS).

### 2 - MACHINE WITH FRAME LEVELING USED ON TIRES

- Correct the tilt using the hydraulic control and check the horizontality with the spirit level. The bubble of the level must be between the two lines (↖ 2 - DESCRIPTION: INSTRUMENTS AND CONTROLS).

### 3 - MACHINE USED ON STABILIZERS

- Set the two stabilizers on the ground and raise the two front wheels of the machine (fig. D1).
- Correct the tilt using the stabilizers (Fig. D2) and check the horizontality with the spirit level. The bubble of the level must be between the two lines (↖ 2 - DESCRIPTION: INSTRUMENTS AND CONTROLS). In this position, the two front wheels must be off the ground.

## E - PICKING UP A LOAD ON THE GROUND

- Approach the machine perpendicular to the load, with the boom retracted and the forks in a horizontal position (fig. E1).
- Adjust the fork spacing and centering relative to the load to ensure stability (Fig. E2) (optional solutions exist, consult your dealer).
- Never lift a load with a single fork.

### ⚠ IMPORTANT ⚠

*Beware of the risks of trapping or squashing limbs when manually adjusting the forks.*

- Move the machine forward slowly (1) and bring the forks up to the stop in front of the load (Fig. E3). If necessary, slightly lift the boom (2) while picking up the load.
- Bring the load into the transport position.
- Tilt the load far enough backward to ensure stability (loss of load on braking or going downhill).

### FOR A NON-PALLETIZED LOAD

- Tilt the carriage (1) forwards and move the machine slowly forwards (2), to insert the fork under the load (Fig. E4) (chock the load if necessary).
- Continue to move the machine (2) forward, tilting the carriage (3) (fig. E4) backward to position the load on the forks and check the load's longitudinal and lateral stability.

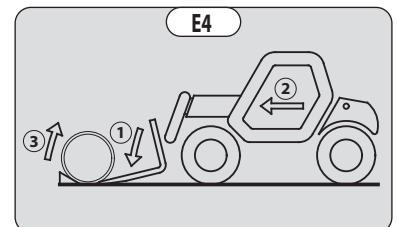
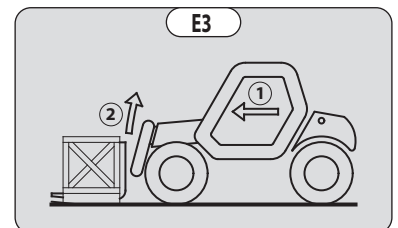
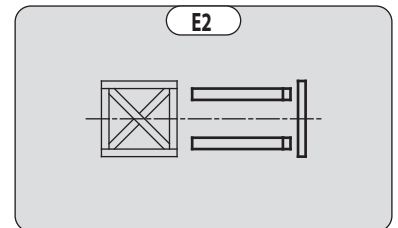
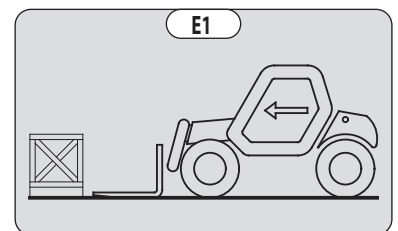
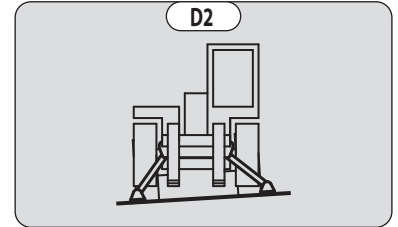
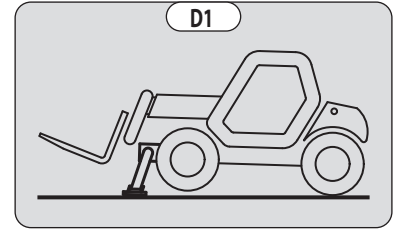

## F - PICKING UP AND PUTTING DOWN A HIGH LOAD ON TIRES

### ⚠ IMPORTANT ⚠

*You must not raise the boom if you have not checked the transverse attitude of the machine (← INSTRUCTIONS FOR HANDLING A LOAD D - TRANSVERSE ATTITUDE OF THE MACHINE).*

REMINDER: Make sure that the following operations can be performed with good visibility (← OPERATING INSTRUCTIONS UNLADEN AND LADEN: D - VISIBILITY).

### PICKING UP A HIGH LOAD ON TIRES

- Ensure that the forks will easily pass under the load.
- Raise and extend the boom (1) (2) until the forks are at the level of the load. If necessary, move the machine (3) forward (fig. F1), driving very slowly and carefully.
- Always remember to keep the distance necessary for inserting the forks under the load, between the stack and the machine (fig. F1) and use the shortest possible length of boom.
- Insert the forks under the load as far as they will go by alternately extending and lowering the boom (1) or, if necessary, moving the machine forward (2) (fig. F2). Activate the parking brake and place the forward/reverse selector in neutral.
- Lift the load slightly (1) and tilt the carriage (2) backwards to stabilize the load (Fig. F3).
- Tilt the load sufficiently backward to ensure its stability.
- Monitor the longitudinal stability indicator (← INSTRUCTIONS FOR HANDLING A LOAD: C - LONGITUDINAL STABILITY INDICATOR). If it is overloaded, set the load back down in the place from which it was picked up.
- If possible, lower the load without moving the machine. Raise the boom (1) to release the load, retract (2) and lower the jib (3) to set the load into transport position (fig. F4).
- If this is not possible, reverse the machine (1), maneuvering very gently and carefully to release the load. Retract (2) and lower the boom (3) to bring the load into the transport position (fig. F5).

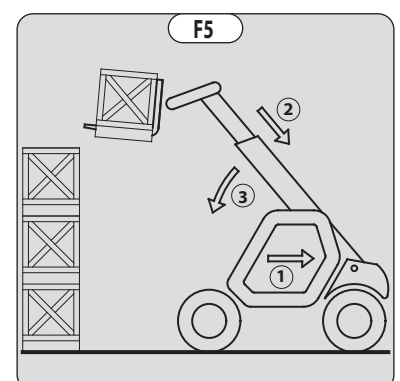
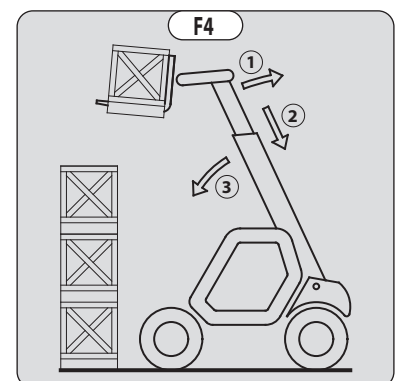
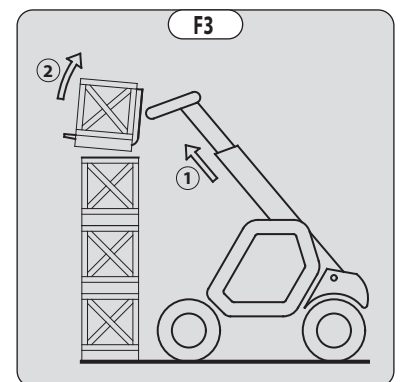
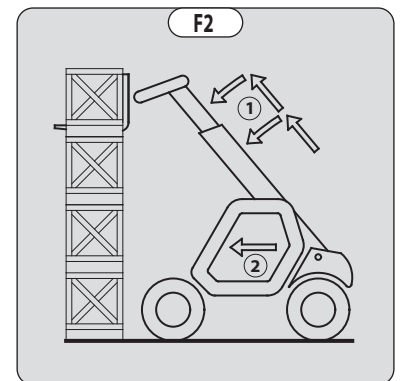
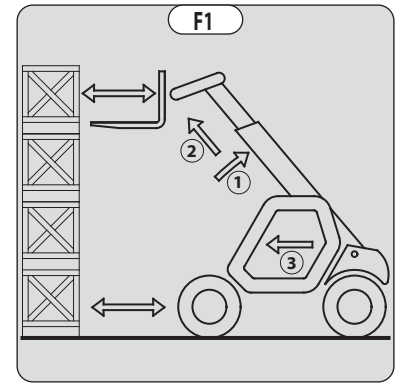

## PUTTING DOWN A HIGH LOAD ON TIRES

- Approach the load in the transport position in front of the stack (Fig. F6).
- Activate the parking brake and place the forward/reverse selector in neutral.
- Raise and extend the boom (1) (2) until the load is above the stack, while monitoring the longitudinal stability indicator (← INSTRUCTIONS FOR HANDLING A LOAD: C - LONGITUDINAL STABILITY INDICATOR). If necessary, move the lift truck (3) forward (fig. F7), driving very slowly and carefully.
- Place the load in a horizontal position and put it down on the pile by lowering and retracting the boom (1) (2) in order to position the load correctly (Fig. F8).
- If possible, release the forks by alternately retracting and raising the boom (1) (Fig. F9). Then set the forks into transport position.
- If this is not possible, reverse the machine (1), maneuvering very slowly and carefully to release the forks (fig. F10). Then set the forks into transport position.

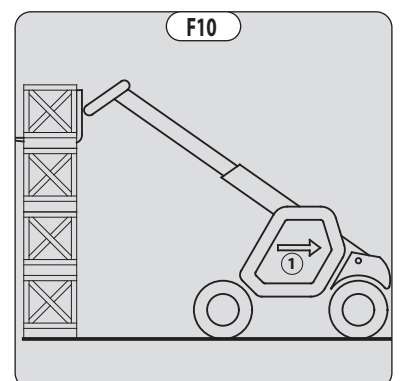
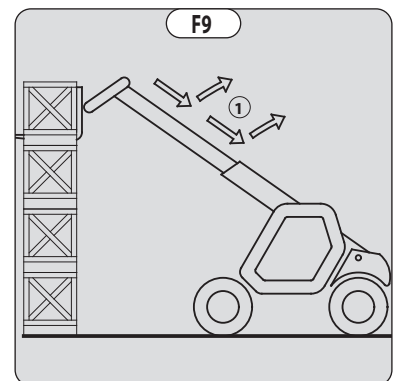
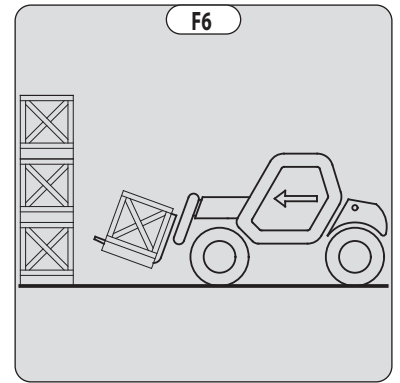

## G - PICKING UP AND PUTTING DOWN A HIGH LOAD ON STABILIZERS

Depending on machine model

### ⚠ IMPORTANT ⚠

*You must not raise the boom if you have not checked the transverse attitude of the machine (← INSTRUCTIONS FOR HANDLING A LOAD D - TRANSVERSE ATTITUDE OF THE MACHINE).*

REMINDER: Make sure that the following operations can be performed with good visibility (← OPERATING INSTRUCTIONS UNLADEN AND LADEN: D - VISIBILITY).

The stabilizers are used to optimize the machine's lifting performance (← 2 - DESCRIPTION: INSTRUMENTS AND CONTROLS).

POSITIONING THE STABILIZERS WITH THE FORKS IN TRANSPORT POSITION (UNLADEN AND LADEN)

- Set the forks in transport position in front of the elevation.
- Stay far enough away to allow the boom to be raised.
- Activate the parking brake and place the forward/reverse selector in neutral.
- Set the two stabilizers on the ground and lift the two front wheels of the machine (fig. G1), while maintaining its transverse stability.

RAISING THE STABILIZERS WITH THE FORKS IN TRANSPORT POSITION (UNLADEN AND LADEN)

- Raise both stabilizers fully and at the same time.

LOWERING THE STABILIZERS WITH JIB UP (UNLADEN AND LADEN)

### ⚠ IMPORTANT ⚠

*This operation must be exceptional and performed with great care.*

- Raise the boom and retract the telescopes completely.
- Set the machine in position in front of the elevation (fig. G2), moving very slowly and carefully.
- Activate the parking brake and place the forward/reverse selector in neutral.
- Move the stabilizers very slowly and gradually as soon as they are close to the ground or in contact with it.
- Lower the two stabilizers and lift the two front wheels of the machine (fig. G3). During this operation, transverse attitude must be permanently maintained: the bubble in the level must be kept between the two lines.

SETTING THE STABILIZERS WITH THE BOOM UP (UNLADEN AND LADEN)

### ⚠ IMPORTANT ⚠

*This operation must be exceptional and performed with great care.*

- Keep the boom raised and retract the telescopes completely (Fig. G3).
- Move the stabilizers very slowly and gradually as soon as they are in contact with the ground and when they leave the ground. During this operation, transverse attitude must be permanently maintained: the bubble in the level must be kept between the two lines.
- Raise both stabilizers completely.
- Deactivate the parking brake and reverse the machine (1) very slowly and carefully to release it and lower the forks (2) into transport position (fig. G4).

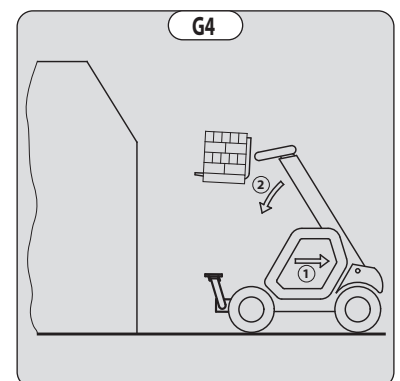
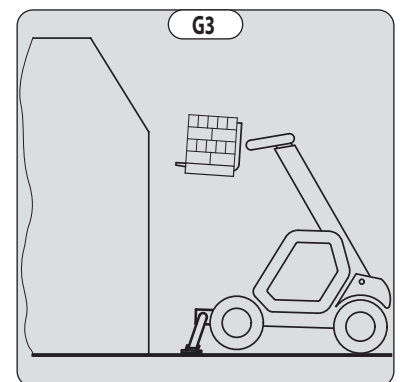
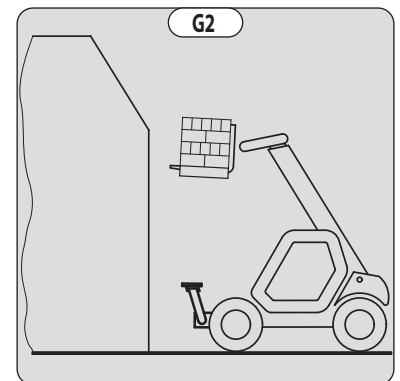
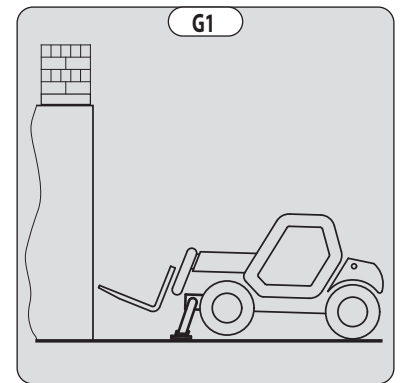

## PICKING UP A HIGH LOAD ON STABILIZERS

- Ensure that the forks will easily pass under the load.
- Check the position of the machine with respect to the load and make a test run, if necessary, without picking up the load.
- Raise and extend the boom (1) (2) until the forks are at the level of the load (Fig. G5).
- Bring the forks to the stop in front of the load by alternately extending and lowering the boom (1) (Fig. G6).
- Lift the load slightly (1) and tilt the carriage (2) backwards to stabilize the load (Fig. G7).
- Monitor the longitudinal stability indicator (⚠ INSTRUCTIONS FOR HANDLING A LOAD: C - LONGITUDINAL STABILITY INDICATOR). If it is overloaded, set the load back down in the place from which it was picked up.
- If possible, lower the load without moving the machine. Raise the boom (1) to release the load, retract (2) and lower the jib (3) to set the load into transport position (fig. G8).

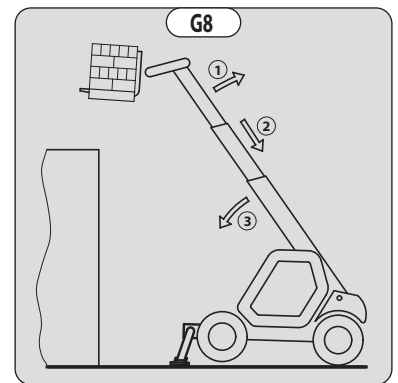
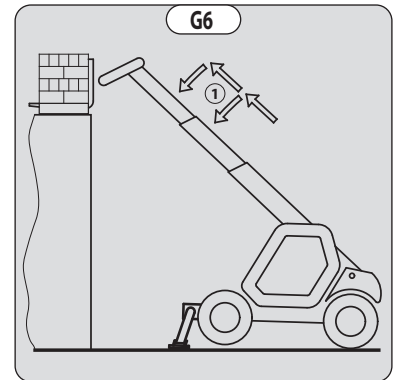
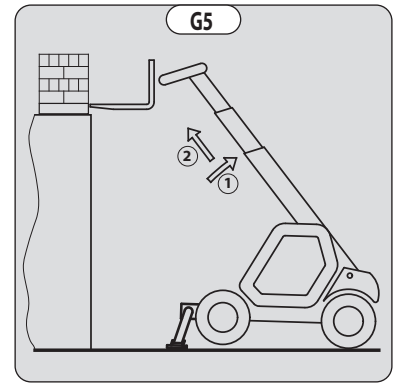

## SETTING DOWN A HIGH LOAD ON STABILIZERS

- Raise and extend the boom (1) (2) until the load is above the elevation (fig. G9), while monitoring the longitudinal stability indicator (⚠ INSTRUCTIONS FOR HANDLING A LOAD: C - LONGITUDINAL STABILITY INDICATOR).
- Position the load horizontally and release it by lowering and retracting the boom (1) (2) to position the load correctly (Fig. G10).
- Free the forks by alternately retracting and raising the boom (3) (Fig. G11).
- If possible, set the boom in transport position without moving the machine.

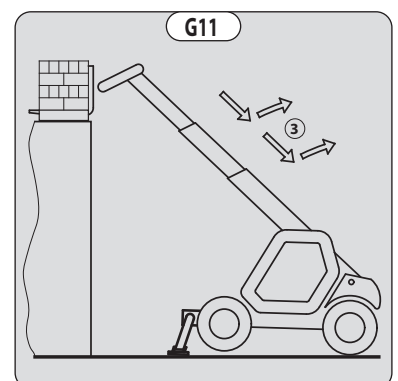
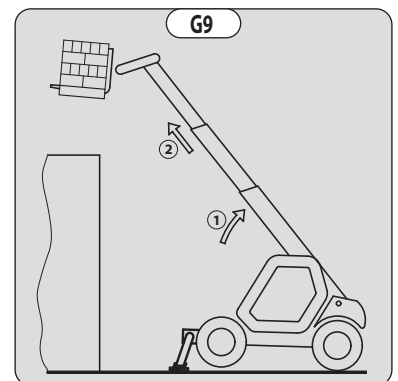

## H - PICKING UP AND PUTTING DOWN A SUSPENDED LOAD

### **⚠ IMPORTANT ⚠**

*Failure to follow the above instructions may lead the machine to lose stability and overturn.*

*MUST be used with a machine equipped with an operational hydraulic movement cut-off device.*

#### CONDITIONS OF USE

- The length of the sling or the chain shall be as short as possible to limit swinging of the load.
- Lift the load vertically along its axis, never by pulling sideways or lengthways.

#### HANDLING WITHOUT MOVING THE MACHINE

- Whether on stabilizers or on tires, the lateral attitude must not exceed 1% and the longitudinal attitude must not exceed 5%: the bubble of the level must be held at "0".
- Ensure that the wind speed is not higher than 10 m/s (32,8 fps).
- Ensure that there is no one between the load and the machine.

#### I - TRAVELING WITH A SUSPENDED LOAD

- Before moving, inspect the terrain in order to avoid excessive slopes and cross-falls, bumps and potholes, or soft ground.
- Ensure that the wind speed is not higher than (36 km/h 22,36 mph)
- The machine must not travel at more than 0.4 m/s (1.5 km/h (0.93 mph), i.e. one quarter walking speed).
- Drive and stop the machine gently and smoothly to minimize swinging of the load.
- Carry the load a few centimeters above the ground (max. 30 cm (11.81 in) the shortest possible jib length. Do not exceed the offset indicated on the load chart. If the load begins to swing excessively, do not hesitate to stop and lower the jib to set down the load.
- During transport, the lift truck operator must be assisted by a person on the ground (standing a minimum of 3 m (9 ft 10 in) from the load), who will limit swinging of the load using a bar or a rope. Ensure that this person is always clearly in view.
- The lateral attitude must not exceed 5%: the bubble in the level must be kept between the two "MAX" marks.
- The longitudinal attitude must not exceed 15% with the load facing uphill and 10% with the load facing downhill.
- The boom angle must not exceed 45°.

## INSTRUCTIONS FOR USE AS A LOADER

For agricultural-type machines (MLT range)

### A - LOADING

#### ⚠ IMPORTANT ⚠

*You must not raise the boom if you have not checked the transverse attitude of the machine (← INSTRUCTIONS FOR HANDLING A LOAD D - TRANSVERSE ATTITUDE OF THE MACHINE).*

REMINDER: Make sure that the following operations can be performed with good visibility (← OPERATING INSTRUCTIONS UNLADEN AND LADEN: D - VISIBILITY).

#### FILLING THE BUCKET

- Place the bottom of the bucket in a horizontal position, just in contact with the ground (1) (Fig. A1).
- Move forward gradually (2) while simultaneously raising the boom and tilting the bucket backwards (3), for improved filling and breakout (Fig. A1).
- Reverse the machine (1) very carefully and gently to free the bucket. Lower the boom (2) into the transport position (Fig. A2).

#### ⚠ IMPORTANT ⚠

*Tilt the bucket sufficiently back to avoid spilling product and ensure its stability (loss of product under braking).*

#### LOADING A TRAILER

- Approach the side of the trailer in the transport position (Fig. A3).
- Raise and extend the boom (1) (2) until the bucket is above the trailer, while monitoring the longitudinal stability indicator (← INSTRUCTIONS FOR HANDLING A LOAD: C - LONGITUDINAL STABILITY INDICATOR) (fig. A4).
- Drive the machine forward (3) very carefully and gently so that the bucket empties its load in the center of the trailer (Fig. A4).
- Immobilize the machine with the brake pedal and put the reversing shift lever in neutral.

N.B.: Immobilizing the machine with the brake pedal means that the transmission should be in neutral. Failure to follow this recommendation may lead to overheating and damage to the brakes.

- Slowly discharge the product (4) (Fig. A4).
- Tilt the bucket backwards (1) and reverse the machine (2) very carefully and gently (Fig. A5).
- Retract (3) and lower the boom (4) into the transport position (Fig. A5).

### B - BACKFILLING

- Place the bottom of the bucket in a horizontal position, just in contact with the ground (1) (Fig. B1).
- Drive forward gradually (2). Once filled, the bucket will act as a leveling blade (Fig. B1).

#### ⚠ IMPORTANT ⚠

*When driving, beware of trenches as well as recently excavated and/or backfilled ground.*

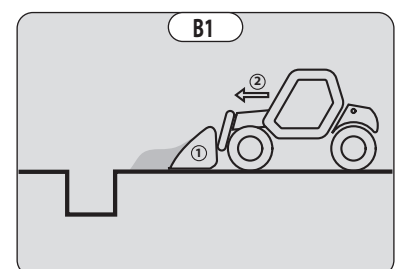
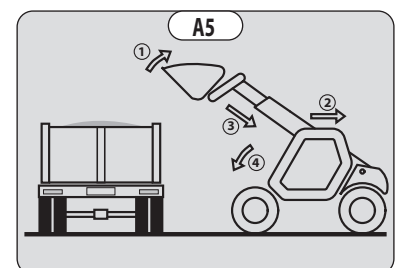
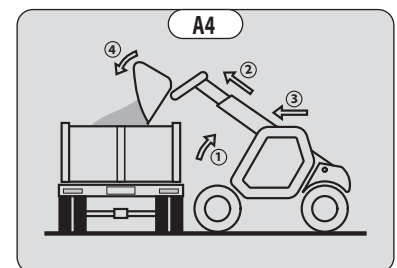
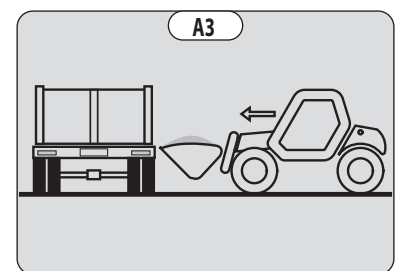
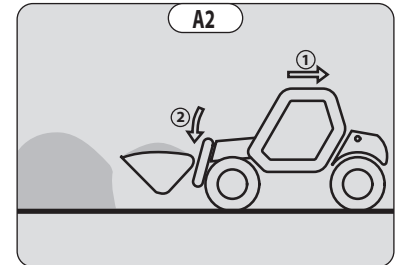
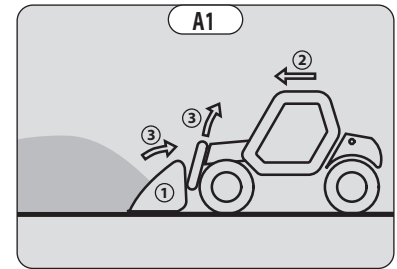

## ***INSTRUCTIONS FOR USING THE MOBILE ELEVATING WORK PLATFORM***

---

For machines equipped with a MOBILE ELEVATING WORK PLATFORM

### **A - AUTHORIZATION FOR USE**

- Operation of the platform requires further authorization in addition to that of the machine.

### **B - SUITABILITY OF THE PLATFORM FOR THE JOB**

- Our machines fitted with mobile elevating work platforms are compliant with standard **EN 280** for Europe and standard **AS/NZS 1418.10:2011** for Australia, corresponding to the classification of Group C1 to C3 in accordance with this standard.
- MANITOU has ensured that this platform is suitable for use under the normal operating conditions provided in this operator's manual, with a STATIC test coefficient of 1.25 and a DYNAMIC test coefficient of 1.1 as specified in harmonized European standard **EN 280** for mobile elevating work platforms.
- Before commissioning, the company manager must make sure that the platform is appropriate for the work to be done, and perform certain tests (in accordance with current legislation).

### **C - PROVIDED ON THE PLATFORM**

- Wear suitable clothing when using the platform, avoid loose-fitting garments.
- Never use the platform with hands or shoes that are wet or soiled with greasy substances.
- Remain alert at all times when using the platform. Do not listen to the radio or music using headphones or earphones.
- MANITOU strongly recommends wearing a safety harness attached to an attachment point in the platform. Wearing a safety harness or other personal protection equipment against falls may be compulsory. Comply with local, government and national regulations in force, employer's safety rules and work site regulations .
- The safety harness or other personal protection equipment against falls must comply with local, government, and national regulations in force. They must be inspected in accordance with the regulations in force.
- The control units must never be used for any other than their intended purposes (e.g. Climbing onto or down from the machine, coat hanger, etc.).
- Safety helmets must be worn.
- The operator must always be in his normal position in the driver's cab: it is prohibited to have arms or legs, or generally any part of the body, outside the platform.
- Ensure that materials loaded onto the platform (pipes, cables, containers, etc.) cannot fall out. Do not pile these materials to the point where it is necessary to step over them.

## D - USING THE PLATFORM

- However experienced they may be, operators must acquaint themselves with the emplacement and operation of all control instruments prior to operating the platform.
- Check before use that the platform has been correctly assembled and locked onto the machine.
- Do not enter or exit the platform unless it is fully lowered.
- Always enter and exit the platform through the gate or using the sliding mid rails (depending on the model).
- Always enter and exit facing the interior of the platform.
- Always use both hands and one foot or both feet and one hand to enter and exit the platform.
- Make sure that the sliding intermediate cross members (depending on the model) are in the lower position and that the gate is properly closed (depending on the model) before using this platform.
- Do not attach the sliding mid rails in the high position.
- The platform should be operated in an area free of any obstructions or danger when it is lowered to the ground.
- The operator using the platform must be aided by someone on the ground with adequate training.
- You should stay within the limits set out in the platform load chart.
- The lateral constraints are limited (↩ 2 - DESCRIPTION: SPECIFICATIONS).
- It is strictly forbidden to suspend a load from the platform or the machine's boom without an attachment provided for the purpose (↩ INSTRUCTIONS FOR HANDLING A LOAD: H - PICKING UP AND PUTTING DOWN A SUSPENDED LOAD).
- The platform cannot be used as a crane or a lift for permanently transporting people or materials, nor as jacks or supports.
- The machine must not be moved with one (or more) person(s) on the platform.
- It is forbidden to transport people on the platform using the hydraulic controls in the machine's cab (except in case of rescue).
- The operator must not climb onto to off the platform when it is not on ground level (jib retracted and in the down position).
- The machine must not be fitted with unauthorized attachments that increase the windage of the assembly.
- Do not use ladders or improvised structures on the platform to gain extra height.
- Do not climb onto the rails of the platform to gain extra height.
- It is forbidden to use the platform on forks. The fork slots are only to, be used for storing the platform and not for lifting people under any circumstances.

**E - ENVIRONMENT**

- Respect a safety distance between power lines or live components and any part of the body, any conductive object or any part of the machine, unless the local, government and national applicable regulations, the safety rules of the employer or construction site regulations are more strict in terms of distance required.
- Allow for platform movement and swaying or sagging power lines.

**⚠ IMPORTANT ⚠**

*It is forbidden to use the platform close to electricity cables. Maintain the specified safe distances.*

RATED VOLTAGE (VOLTS)	SAFETY DISTANCE (FT-IN/METRES)
50 < U < 1000	7-6.55/2,30
1000 < U < 30000	8-2.42/2,50
30000 < U < 45000	8-6.36/2,60
45000 < U < 63000	9-2.23/2,80
63000 < U < 90000	9-10.11/3,00
90000 < U < 150000	11-1.85/3,40
150000 < U < 225000	13-1.48/4,00
225000 < U < 400000	17-4.66/5,30
400000 < U < 750000	25-11.02/7,90

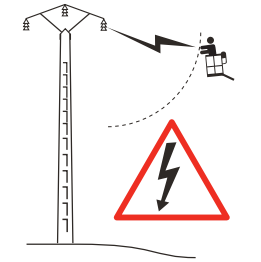

**⚠ IMPORTANT ⚠**

*It is strictly forbidden to use the platform when the wind speed exceeds 45 km/h (27.96 mph).*

- To visually recognize this wind speed, refer to the empirical wind evaluation scale below:

BEAUFORT scale (wind speed at a height of 32-9,7 ft-in (10 m) on a flat site)							
Force	Type of wind	Speed (knots)	Speed (mph)	Speed (km/h)	Speed (m/s)	Effects on Land	Sea conditions
0	Calm	0 - 1	0 - 1	0 - 1	<0.3	Smoke rises vertically.	Sea is like a mirror.
1	Light air	1 - 3	1 - 3	1 - 5	0.3 - 1.5	Smoke indicates direction of wind.	Ripples with appearance of scale, no foam crests.
2	Light breeze	4 - 6	4 - 7	6 - 11	1.6 - 3.3	Wind felt on face, leaves rustle.	Short wavelets, but pronounced.
3	Gentle breeze	7 - 10	8 - 12	12 - 19	3.4 - 5.4	Leaves and small twigs in constant motion.	Very small waves, crests begin to break.
4	Moderate breeze	11 - 16	13 - 18	20 - 28	5.5 - 7.9	Wind raises dust and loose pieces of paper; small branches are moved.	Small waves, becoming longer, numerous whitecaps.
5	Fresh breeze	17 - 21	19 - 24	29 - 38	8 - 10.7	Small trees in leaf begin to sway.	Wavelets form on inland waters; moderate waves, taking longer form.
6	Strong breeze	22 - 27	25 - 31	39 - 49	10.8 - 13.8	Large branches in motion, whistling heard in overhead wires, umbrella use becomes difficult.	Larger waves forming, whitecaps everywhere, some spray.
7	Near gale	28 - 33	32 - 38	50 - 61	13.9 - 17.1	Whole trees in motion, inconvenience felt when walking against the wind.	Sea heaps up; white foam from breaking waves begins to be blown in streaks along the direction of the wind.
8	Gale	34 - 40	39 - 46	62 - 74	17.2 - 20.7	Wind breaks twigs off trees; impedes progress.	Moderately high waves of greater length; edges of crests begin to break into spindrift.
9	Strong gale	41 - 47	47 - 54	75 - 88	20.8 - 24.4	Wind damages roofs (chimneys, slates, etc.).	High waves, crests of waves begin to topple, streaks of foam; reduced visibility.
10	Storm	48 - 55	55 - 63	89 - 102	24.5 - 28.4	Seldom experienced inland; trees uprooted; considerable structural damage occurs.	Very high waves; white streaks of foam; reduced visibility.
11	Violent storm	56 - 63	64 - 72	103 - 117	28.5 - 32.6	Very rare, widespread damage.	Exceptionally high waves able to hide medium sized ships from view, reduced visibility.
12	Hurricane	64 +	72 +	118 +	32.7 +	Devastating damage.	Sea completely white; air filled with foam and spray, very reduced visibility.

**F - MAINTENANCE**

**⚠ IMPORTANT ⚠**

*Your platform must be periodically inspected to ensure its continued compliance.*

*The frequency of this inspection is defined by the legislation in force in the country in which the platform is used.*

*In France, a general periodic inspection every 6 months (Decree of March 1, 2004).*

## INSTRUCTIONS FOR USING THE RADIO-CONTROL

For machines with RC radio control

### HOW TO USE THE RADIO-CONTROL

#### SAFETY INSTRUCTIONS

#### **⚠ IMPORTANT ⚠**

*It is prohibited to lift people in the platform using the radio-control.*

*It is prohibited to use the radio-control from the platform:*

- This radio-control consists of electronic and mechanical safety elements. It cannot receive commands from another transmitter because the internal encoding is unique to each radio-control.

#### **⚠ IMPORTANT ⚠**

*If it is used improperly or incorrectly, there is a risk of danger to:*

- *The physical and mental health of the user or others.*
- *The machine and other neighboring items.*

*Everyone working with this radio-control:*

- *Must be qualified in line with current regulations and trained accordingly.*
- *Must follow this instruction manual as closely as possible.*

- The system is used to control the machine remotely via radio waves. Commands are also transmitted if the machine is out of sight (behind an obstacle or a building for example), this is why:
  - After stopping the truck and removing the key switch (only possible when it is stationary), always place the transmitter in a safe, dry place.
  - Before performing any installation, servicing or repair work, always switch off power sources (in particular, electric welding devices and electric head units on hydraulic distributors must be disconnected at each section).
  - Never remove or alter the safety devices (such as the hand-guard frame, key, emergency stop button, etc.).

#### **⚠ IMPORTANT ⚠**

*Never drive the machine if it is not continuously and perfectly within view of the operator.*

- Before leaving the transmitter, the operator must make sure that it cannot be used by an unauthorized third person: either by removing the key button from the transmitter or locking it in an inaccessible place.
- The user must ensure that the instruction manual is accessible at all times and that operators have read and understood it.

#### INSTRUCTIONS

- Take up position in a stable place with no risk of slipping.
- Before using the transmitter, make sure there is nobody within the working area.
- Only use the transmitter with its carrying device or installed correctly on the platform.

#### **⚠ IMPORTANT ⚠**

*When you remove the transmitter, remove the accumulator and key button so that it cannot be used accidentally or deliberately by anyone else.*

#### PROTECTIVE DEVICES

- The machine will be immobilized within a maximum of 450 milliseconds (approx. 0.5 second):
  - If the emergency stop button of the transmitter is pressed (50 milliseconds), or that of the machine.
  - If the transmission distance of the radio waves is exceeded.
  - If the transmitter is faulty.
  - If an interfering radio signal is received from elsewhere.
  - If the accumulator is removed from its housing in the transmitter.
  - If the battery reaches the end of its autonomy.
  - If the transmitter is switched off by turning the key switch to the off position.
- These protective devices are provided for the safety of personnel and property and must never be modified, removed or bypassed in any way whatsoever!
- The hand-guard frame prevents external action on a joystick (e.g. if the transmitter is dropped, or if the operator leans on a guard-rail).
- An electronic safety device prevents radio transmission from being initiated if the joysticks are not mechanically and electrically at rest and if the internal combustion engine speed selector is not set to idle.

#### **⚠ IMPORTANT ⚠**

*In an emergency, press the transmitter emergency stop button immediately; then follow the manual's instructions (← 2 - DESCRIPTION: INSTRUMENTS AND CONTROLS).*

# MACHINE MAINTENANCE INSTRUCTIONS

## GENERAL INSTRUCTIONS

### ⚠ IMPORTANT ⚠

Carefully read and understand this operator's manual before any operation on this machine.

Carry out all repairs immediately, even if the repairs concerned are minor.

Repair all leaks immediately, even if the leak concerned is minor.

Be careful of the risk of burns and splashing (exhaust, radiator, engine, hydraulic oil, etc.).

- Make sure the area is adequately ventilated before starting up the machine.
- Wear clothes suitable for the maintenance of the machine. Avoid wearing jewelry and loose clothes. Tie back and protect your hair, if necessary.
- Stop the engine and remove the ignition key before carrying out any work.

## PLACING THE JIB SAFETY WEDGE

- The machine is equipped with a boom safety wedge (↖ 2 - DESCRIPTION: INSTRUMENTS AND CONTROLS) that must be installed on the lifting cylinder rod when working beneath the boom.
- Boom retracted without forks or attachments.

ACCORDING TO INSTALLATION

### FITTING THE WEDGE

- Fully raise the jib.
- Place the safety wedge 1 on the rod of the lifting cylinder and secure with the rod 2 and the pin 3.
- Slowly lower the jib then stop the hydraulic movements before it comes into contact with the wedge.

### REMOVING THE WEDGE

- Fully raise the jib.
- Remove the pin and the rod.
- Return the safety wedge to the storage location provided on the machine.

### ⚠ IMPORTANT ⚠

Only use the wedge supplied with the machine.

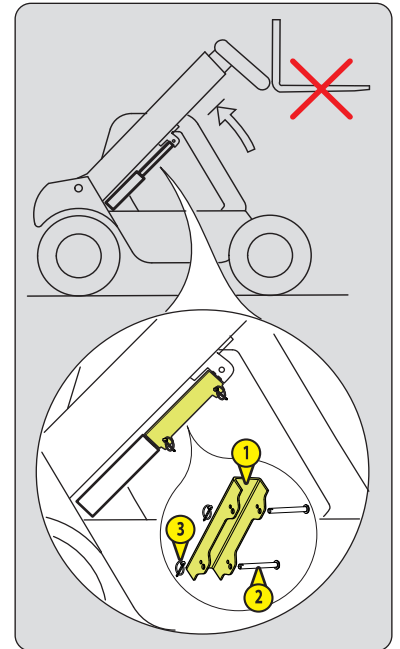

ACCORDING TO INSTALLATION

### FITTING THE WEDGE

- Fully raise the jib.
- Loosen the thumbwheels 1.
- Assemble the parts of the safety wedge 2 around the cylinder rod and lock with the pins 3.

NOTE: the stop flats 4 of the safety wedge must be located towards the bottom of the lifting cylinder 5.

- Slowly lower the jib then stop the hydraulic movements before it comes into contact with the wedge.

### REMOVING THE WEDGE

- Fully raise the jib.
- Remove the pins 3.
- Put the parts of the safety wedge 2 back on the machine and lock them with the thumbwheels 1.
- Replace the pins 3 on the parts of the safety wedge.

### ⚠ IMPORTANT ⚠

Only use the wedge supplied with the machine.

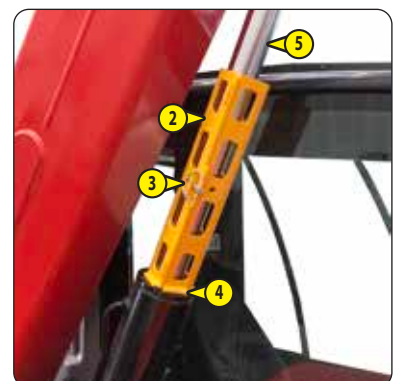
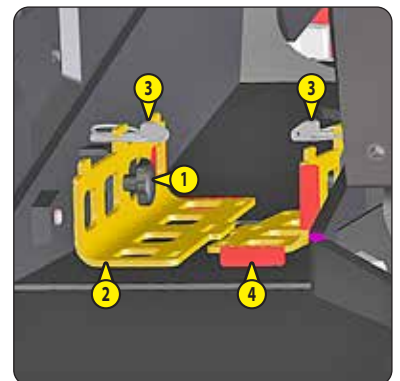

## **MAINTENANCE**

---

- Perform the periodic service (↩ 3 - MAINTENANCE) to keep your machine in good working order. Failure to perform periodic maintenance may invalidate the contractual warranty.

### **MAINTENANCE LOGBOOK**

- The maintenance operations carried out in accordance with the recommendations given in section 3 - MAINTENANCE and the other inspection, servicing or repair operations or modifications performed on the machine shall be recorded in a maintenance logbook.
- The entry for each operation should include the date of the work, the names of the individuals or companies having performed them, the type of operation and its frequency, if applicable.
- If machine elements are replaced, the part numbers of these elements shall be indicated.

## **LUBRICANT AND FUEL LEVELS**

---

- Use the recommended lubricants (never use contaminated lubricants).
- Do not fill the fuel tank when the engine is running.
- Only fill up the fuel tank in areas specified for this purpose.
- Do not fill the fuel tank to the maximum level.
- Do not smoke or approach the machine with a flame when the fuel tank is open or is being filled.

## **HYDRAULICS**

---

- Any work on the load handling hydraulic circuit is forbidden except for the operations described in chapter: 3 - MAINTENANCE.
- Do not attempt to loosen unions, hoses or any hydraulic component with the circuit under pressure.



**COUNTERBALANCE VALVE:** *it is dangerous to change the setting or remove the counterbalance valves or safety valves which may be fitted to the cylinders of your machine.*

**HYDRAULIC ACCUMULATOR:** *dismantling hydraulic accumulators and their pipes which may be fitted on your machine is dangerous. Such operations must only be performed by approved personnel (consult your dealer).*

## **ELECTRICITY**

---

- Do not short-circuit the starter relay to start the engine. If the forward/reverse selector is not in neutral and the parking brake is not on, the machine may suddenly start to move.
- Do not place metal items on the battery.
- Disconnect the battery before working on the electrical circuit.

## **WELDING ON THE MACHINE**

---



**Welding operations on the machine for the purposes of maintenance or repairs must only be carried out by people authorized by MANITOU.**

- Disconnect the battery before any welding operations on the machine.
- When carrying out electric welding work on the machine, connect the negative cable from the equipment directly to the part being welded so as to avoid very high current passing through the alternator.
- Never carry out welding or work which gives off heat on an assembled tire. The heat would increase the pressure which could cause the tire to explode.
- If the machine is equipped with an electronic control unit, disconnect it before starting to weld so as to avoid the risk of causing irreparable damage to electronic components.

## WASHING THE MACHINE

---

### **⚠ IMPORTANT ⚠**

*When washing with a high pressure cleaner, avoid the engine air intakes, the cylinder rod wiper seals, the hinges, the structural components and the electrical connections, etc.*

- Clean the machine or at least the area concerned before any intervention.
- Remember to close and lock all openings on the machine (doors, windows, cowls, etc.).
- If necessary, protect against penetration of water, steam or cleaning agents, components susceptible of being damaged, particularly electrical components and connections and the injection pump.
- Clean the machine of any traces of fuel, oil or grease.

## TRANSPORTING THE MACHINE

---

### **⚠ IMPORTANT ⚠**

*Transporting the machine involves real risks for the operator and others involved.*

- Towing, winching, slinging or transporting the machine (⚠ 3 - MAINTENANCE).

## PROLONGED MACHINE SHUTDOWN

### INTRODUCTION

---

### **⚠ IMPORTANT ⚠**

*Procedures to follow for long duration standstill and for bringing back the machine into service must be performed by your dealership.*

*This period of long duration standstill must not exceed 12 months.*

*After 12 months, repeat the procedures for putting the machine back into service and long-term shutdown.*

The recommendations below are intended to prevent the machine from being damaged when it is not used for a period of more than 3 months.

### PREPARATION OF THE MACHINE

---

- Clean the machine thoroughly.
- Check and repair any fuel, oil, water or air leaks.
- Replace or repair any worn or damaged parts.
- Wash the painted surfaces of the machine in clear and cold water and wipe them.
- Touch up the paintwork if necessary.
- Lower the lifting structure fully.
- Retract the telescopic arms.
- Release the pressure in the hydraulic circuits.
- Shut down the machine.

### DEF (Diesel Exhaust Fluid) TANK

---

Depending on machine model

- Drain down and rinse the DEF (Diesel Exhaust Fluid) tank.
- Replace the "DEF" (Diesel Exhaust Fluid) feed pump filter (⚠ 3 - MAINTENANCE).
- Slowly fill the tank with new DEF up to the bottom of the filler neck.
- Start up the machine to pressurize the circuit and bring it up to working temperature, then shut down the engine.
- If necessary, top up the tank.

## PROTECTING THE ENGINE

---

- Contact your dealer to obtain the procedure for protecting the inside of the engine (use of protection product).
- Fill the tank with fuel (<img alt="arrow icon" data-bbox="245 85 260 100"/> 3 - MAINTENANCE).
- Replace the engine oil and oil filter (<img alt="arrow icon" data-bbox="245 100 260 115"/> 3 - MAINTENANCE).
- Replace the coolant (<img alt="arrow icon" data-bbox="245 115 260 130"/> 3 - MAINTENANCE).
- Leave the engine running at idling speed for a few minutes, then switch off.
- Run the engine for a short time so that the oil and cooling liquid circulate inside.
- Disconnect the battery and store it in a safe place away from the cold, after charging it to maximum capacity.
- Block the outlet with waterproof adhesive tape.
- Remove the drive belts and store them in a safe place.
- Disconnect the engine cut-off solenoid on the injection pump and carefully insulate the connection.

## MACHINE PROTECTION

---

Place the machine on level ground.

- Set the machine on axle stands so that the tires are off the ground.
- Deactivate the parking brake (*depending on machine model*).
- Protect cylinder rods which will not be retracted from corrosion.
- Wrap the wheels.

N.B.: If the machine is to be stored outdoors, cover it with a waterproof tarpaulin.

## RETURNING THE MACHINE TO SERVICE

---

### **IMPORTANT**

*Make sure the area is adequately ventilated before starting up the machine.*

- Remove the waterproof adhesive tape from all the orifices.
- Remove the protection from the cylinder rods and wheels.
- Refit and reconnect the battery.
- Activate the parking brake and remove the axle stands.
- Perform the daily maintenance operations (<img alt="arrow icon" data-bbox="245 480 260 495"/> 3 - MAINTENANCE).
- Perform the weekly maintenance operations (<img alt="arrow icon" data-bbox="245 495 260 510"/> 3 - MAINTENANCE).
- Drain and clean the fuel tank (<img alt="arrow icon" data-bbox="245 510 260 525"/> 3 - MAINTENANCE).
- Fill the fuel tank with clean diesel filtered through the filler port.
- Replace the fuel filter (<img alt="arrow icon" data-bbox="245 525 260 540"/> 3 - MAINTENANCE).
- Replace the fuel pre-filter (<img alt="arrow icon" data-bbox="245 540 260 555"/> 3 - MAINTENANCE) (*depending on the model of machine*).
- Drain and rinse the DEF tank (*depending on the machine model*).
- Top up, slowly fill the tank with new "DEF" (Diesel Exhaust Fluid) up to the bottom of the filler neck (*depending on the machine model*).
- Refit and set the tension in the belts. (<img alt="arrow icon" data-bbox="245 605 260 620"/> 3 - MAINTENANCE).
- Turn the engine over with the starter, to allow the oil pressure to rise.
- Reconnect the engine cut-off solenoid.
- Lubricate the machine completely (<img alt="arrow icon" data-bbox="245 650 260 665"/> 3 - MAINTENANCE).
- Start up the machine, following the operating and safety instructions (<img alt="arrow icon" data-bbox="245 665 260 680"/> OPERATING INSTRUCTIONS UNLADEN AND LADEN).
- Perform all the lifting structure's hydraulic movements up to the end position for each cylinder.

## DISPOSING OF THE MACHINE

### **⚠ IMPORTANT ⚠**

*Consult your dealer before disposing of the machine.*

### **RECYCLING OF MATERIALS**

---

#### **METALS**

- Metals are 100% recoverable and recyclable.

#### **PLASTICS**

- Plastic parts are identified with a marking in accordance with current regulations.
- A limited range of materials is used to simplify the recycling process.
- The majority of the plastic components are made of "thermoplastic" plastics, which are easily recycled by melting, granulating or grinding.

#### **RUBBER**

- Tires and seals can be ground for use in cement manufacture or to obtain reusable granules.

#### **GLASS**

- Glass items can be removed and collected for processing by glaziers.

### **ENVIRONMENTAL PROTECTION**

---

By entrusting the maintenance of your machine to the MANITOU network, the risk of pollution is limited and the contribution to environmental protection is made.

#### **WORN OR DAMAGED PARTS**

- Do not dump them in the countryside.
- MANITOU and its network have signed-up to a scheme of environmental protection through recycling.

#### **USED OIL**

- The MANITOU network organizes the collection and processing of used oil.
- By handing over your waste oil to MANITOU, the risk of pollution is limited.

#### **USED BATTERIES**

- Do not throw away batteries, as they contain metals that are harmful for the environment.
- Return them to the MANITOU network or any other approved collection point.

N.B.: MANITOU aims to manufacture machines that provide the best performance and limit polluting emissions.

## ***2 - DESCRIPTION***



## 2 - DESCRIPTION

<b><u>SAFETY PLATES AND STICKERS</u></b>	<b>2-4</b>
<b><u>IDENTIFICATION OF THE LIFT TRUCK</u></b>	<b>2-8</b>
<b><u>CHARACTERISTICS</u></b> MT 733...	<b>2-12</b>
<b><u>CHARACTERISTICS</u></b> MT 933...	<b>2-14</b>
<b><u>TYRES</u></b>	<b>2-16</b>
<b><u>DIMENSIONS AND LOAD CHARTS</u></b> MT 733...	<b>2-18</b>
<b><u>DIMENSIONS AND LOAD CHARTS</u></b> MT 933...	<b>2-20</b>
<b><u>VISIBILITY</u></b>	<b>2-22</b>
<b><u>INSTRUMENTS AND CONTROLS</u></b>	<b>2-24</b>
<b><u>TOWING DEVICE</u></b>	<b>2-46</b>
<b><u>DESCRIPTION AND USE OF THE OPTIONS</u></b>	<b>2-48</b>

# SAFETY PLATES AND STICKERS

## ⚠ IMPORTANT ⚠

Clean all stickers and safety plates so that they are legible.  
 Any safety plates and stickers which are illegible or damaged must be replaced.  
 Check that stickers and safety plates are present after replacing any spare parts.

### EXTERNAL PLATES AND STICKERS

REF.	PART No.	DESCRIPTION
1	24653	-Slinging point
2	52563320	-Tie-down point
3	234798	-Hydraulic oil
4	296998	-Safety instruction
5	234805	-Hydraulic coupling instruction (OPTION)
6	52567646	-Emergency output
7	288174	-Accumulator instructions
8	307508	-Battery cut-off instruction
9	305405	-Fuel instruction
10	52552739	-Air conditioning (OPTION)
11	256513	-Boom electrical predisposition (OPTION)
12	250707	-Fan reversal (OPTION)
21	52588611	-Attachment and boom safety
22	52590031	-Attachment retaining shaft

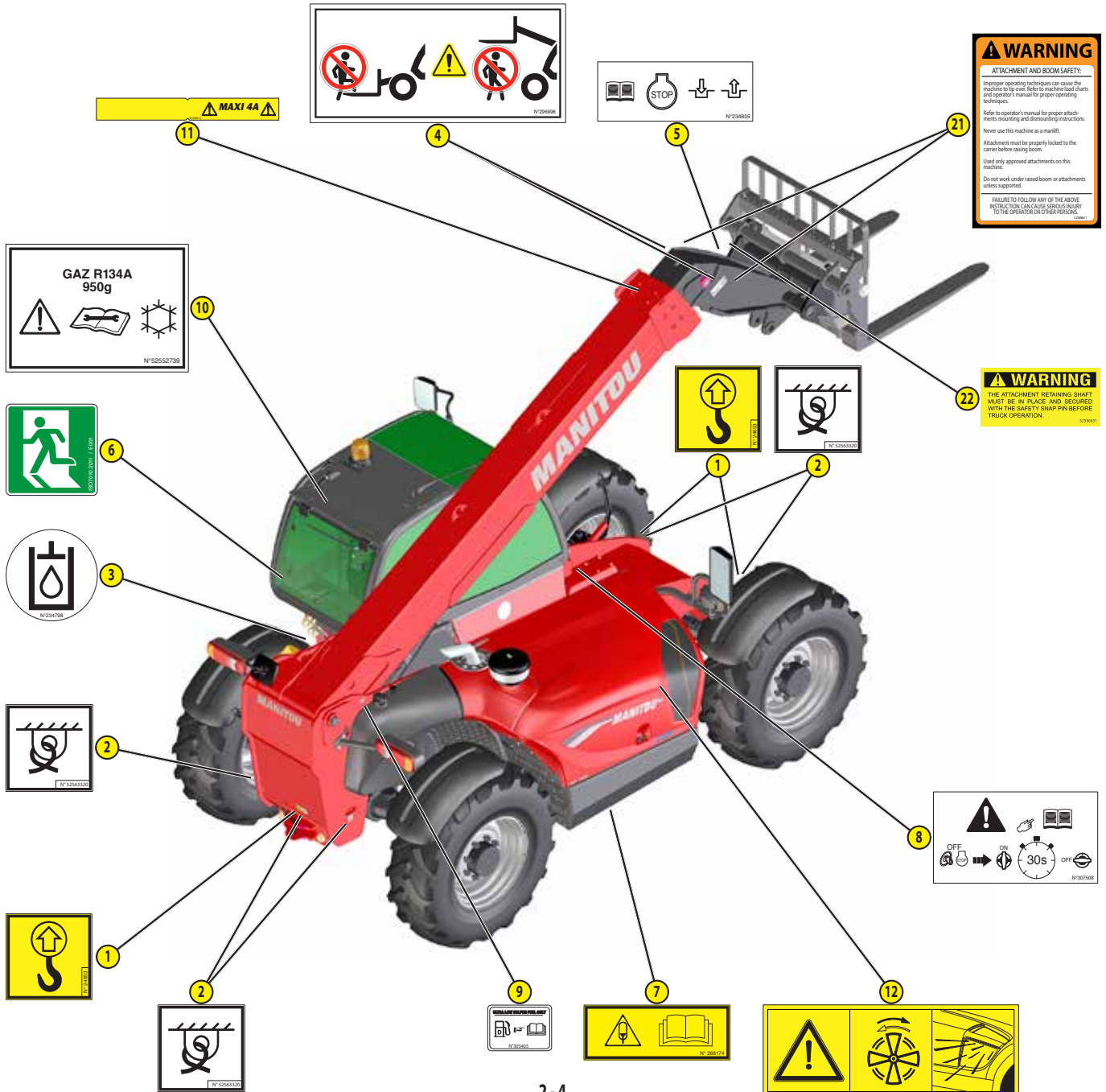



**PLATES AND STICKERS IN THE CAB**

REF.	PART No.	DESCRIPTION
1	193032	- Cab compliance
2	223324	- Patents
3	33460	- Gear selection
4	239594	- Sound power 104 dB
5	184276	- Steering selection control
6	290183	- Bucket instruction on telescope
7	268491	- Brake fluid instruction
8	52653778	- Fuses
9	52503175	- Reach chart sheet
10	241621	- Safety instruction
11	272040	- Transmission cut-off switch function
12	286277	- Joystick function
13	52588616	- Frame leveling warning
16	52599676	- Lubrication sheet
18	52527269	- Consumption sheet MT 733...
19		- Consumption sheet MT 933...
21	52651762	- Hydraulic controls activation
22	52655274	- Load chart for lifting ring on single carriage
23	265284	- Lifting ring on single carriage (OPTION)
24	52523027	- Load chart for lifting ring on single carriage (OPTION) MT 733...
25	52523028	- Load chart for lifting ring on single carriage (OPTION) MT 933...
26	52588612	- Before starting or operating
27	52588614	- No riders
28	52588615	- Power line
29	52588617	- Seat belt
30	52618158	- PROP 65 warning plomb
31	52618159	- PROP 65 warning diesel engine exhaust
32	52628703	- ADH CAN ICES-2 NMB-2

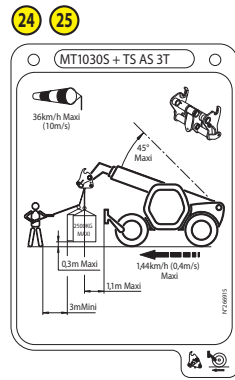
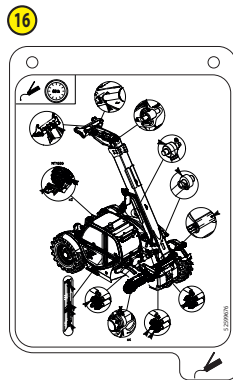
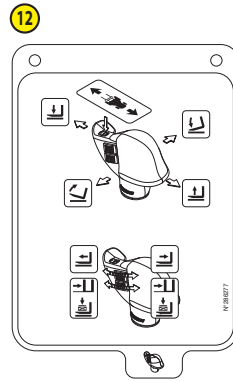
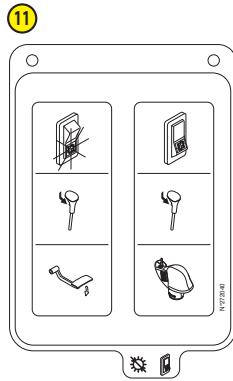

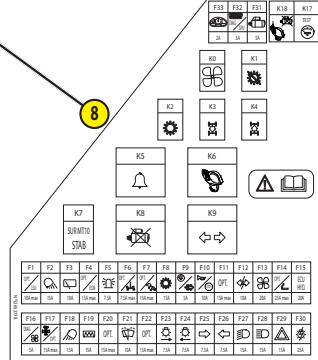
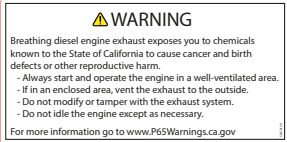
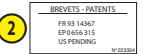
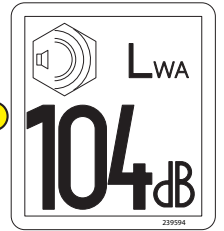
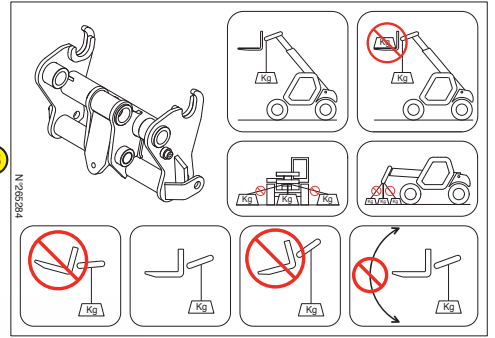
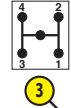
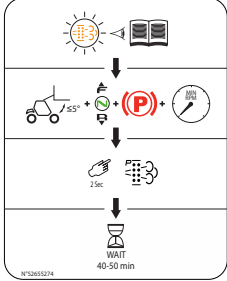
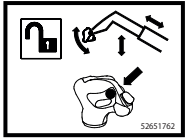
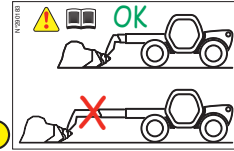

32

1

2

26

30

31

27

7

8

4

23

6

13

28

29

21

22

5

3

## IDENTIFICATION OF THE LIFT TRUCK

As our policy is to promote a constant improvement in our products, our range of lift trucks may undergo certain modifications, without any obligation for us to advise our customers.

When you order parts, or when you require any technical information, always specify the following information.

NOTE: For the owner's convenience, it is recommended that a note of these numbers is made in the spaces provided, at the time of the delivery of the lift truck.

For any further technical information regarding your lift truck refer to: CHARACTERISTICS.

### LIFT TRUCK MANUFACTURER'S PLATE

"Designation" Designation	
"Series" Series	
"Year of manufacture" Year of manufacture	
"Model year" Model year	
"Serial Number / Product Identification Number" Serial number/Product identification number	
"Unladen mass" Unladen weight	
"Power" Power	
"Authorized gross vehicle weight" Authorised gross vehicle weight	
"Rated capacity" Rated capacity	
"Max vertical force (on trailer hook)" Maximum vertical force (on towing hook)	
"Drag strain" Pulling force	



### ENGINE

"MODEL" Model	
"CODE" Code	
"E1" Identification	
"SERNO" Serial number	
"SPEC" Specification	

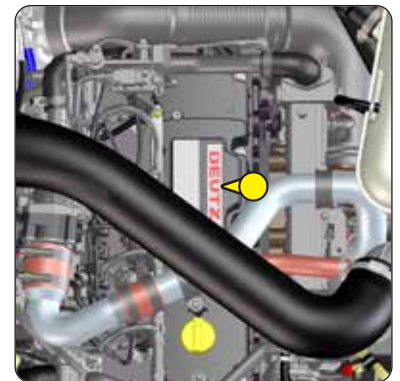

### GEARBOX

MANITOU Part No.	
Type	
Serial number	



### ANGLE GEAR-BOX

MANITOU Part No.	
Type	
Serial number	



### FRONT AXLE

Type	
Serial number	
MANITOU Part No.	



### REAR AXLE

Type	
Serial number	
MANITOU Part No.	



### CAB

"Constructeur" Manufacturer	
"Type Cabine" Cabin type	
"N° de série" Serial number	

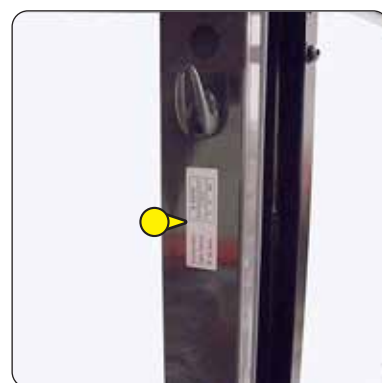

### BOOM

MANITOU Part No.	
Date of manufacture and manufacturer	



## FRAME

Serial number/Product identification number	
---------------------------------------------	--



## ATTACHMENT MANUFACTURER'S PLATE

"MODELE" Model	
"N° série" Serial number	
"Année Fabrication" Year of manufacture	
"Masse à vide" Unladen weight	
"Centre de gravité" Centre of gravity	
"Capacité Nominale" Rated capacity	
"Pression service" Working pressure	





<b>ENGINE</b>		
Type		DEUTZ TD3.6L/2501-2848
Fuel		Diesel
Number of cylinders		4 in line
Suction		Supercharged
Injection system		Direct
Ignition sequence		1.3.4.2
Capacity	cu.in (cm <sup>3</sup> )	221 (3621)
Bore and stroke	in (mm)	3.86 x 4.72 (98 x 120)
Compression ratio		18:1
Nominal speed laden	rpm	2200
Min. rpm unladen	rpm	930
Max. rpm unladen	rpm	2360
Power ISO/TR 14396	hp - kW	75 - 55,4
Power SAE J 1995	hp - kW	75 - 55,4
Maximum torque ISO/TR 14396	ft-lbs (Nm)	250.77 (340) to 1600 rpm
Air filtration efficiency	%	99,9
Type of cooling		By water
Fan		Puller
<b>TRANSMISSION</b>		
Gearbox		TURNER
- Type		Mechanical
- Reversing shift		Electro-hydraulic
- Torque converter		SACHS
- Number of forward speeds		4
- Number of reverse speeds		4
Angle gear box		TURNER
Front axle		DANA
- Differential		Limited slip
Rear axle		DANA
- Differential		Without locking
Drive wheels		Permanent 4 WD
- 2/4 wheel drive control		No
Front tyres		ALLIANCE
- Size		400/80-24 A325 162A8 ATG
- Pressure	psi (bar)	43.5 (3)
Rear tyres		ALLIANCE
- Size		400/80-24 A325 162A8 ATG
- Pressure	psi (bar)	43.5 (3)
<b>ELECTRIC CIRCUIT</b>		
Battery	STANDARD	12 V - 180 Ah - 900 A EN
	OPTION	12 V - 180 Ah - 1235 A EN
Alternator		14V - 95 A
- Type		ISKRA AAK3869
Starter		12 V - 3,2 kW
- Type		ISKRA AZE4668
<b>BRAKE SYSTEM</b>		
Service brake		Hydraulic power brake
- Type of brake		Oil-immersed multi-disc brake
- Type of control		Foot-operated for the front and rear axles
Parking brake		Mechanical
- Type of brake		Disk on gear-box output
- Type of control		Manual
<b>SOUND AND VIBRATION</b>		
Sound pressure level in the driver's cab LpA (according to standard NF EN 12053)	dB(A)	79 (cab closed); xx (cab open)
Sound pressure (according to Directive 2009/76)	dB(A)	xx (cab closed); xx (cab open)
Sound pressure level ensured in the LwA environment (according to Directive 2000/14/EC modified by Directive 2005/88/EC)	dB(A)	104 (measured); 104 (guaranteed)
Sound level in motion (according to Directive 2009/63)	dB(A)	xx
Average weighted acceleration on driver's body (according to standard NF EN 13059)	fps <sup>2</sup> (m/s <sup>2</sup> )	3.61 (1,1)
The average weighted acceleration transmitted to the driver's hand/ arm system (according to standard ISO 5349-2)	fps <sup>2</sup> (m/s <sup>2</sup> )	< 8.2 (< 2,5)
Standard seat vibration	fps <sup>2</sup> (m/s <sup>2</sup> )	xx (lightweight operator); xx (heavyweight operator)

<b>HYDRAULIC CIRCUIT</b>			
Hydraulic pump		Gear pump with flow divider	
- Type		1st casing	2nd casing
- Capacity	cu.in (cm <sup>3</sup> )	2.38 (39)	1.28 (21)
- Max. rating capacity unladen	gpm (L/min)	24.57 (93)	13.21 (50)
- Flow rate at 1,600 rpm	gpm (L/min)	16.64 (63)	8.99 (34)
Filtration			
- Return	mil (µm)	0.39 (10)	
- Suction	mil (µm)	4.92 (125)	
Maximum service pressure		3771 (260)	
- Telescoping circuit	psi (bar)	2755.7 (190) / 3771 (260)	
- Lifting circuit	psi (bar)	3771 (260) / 3771 (260)	
- Tilting circuit	psi (bar)	3771 (260) / 2755.7 (190)	
- Attachment circuit (OPTION)	psi (bar)	3771 (260)	
- Steering circuit	psi (bar)	2030.5 (140)	

<b>HYDRAULIC MOVEMENTS</b>			
Lifting motions (boom retracted)			
- Unladen lifting	s - fpm (m/min)	8,3 - 106.63 (32,5)	
- Laden lifting	s - fpm (m/min)	9 - 98.43 (30)	
- Unladen lowering	s - fpm (m/min)	6 - 147.64 (45)	
- Laden lowering	s - fpm (m/min)	6,1 - 145.34 (44,3)	
Telescoping motions (boom raised)			
- Unladen extending	s - fpm (m/min)	7,3 - 70.87 (21,6)	
- Laden extending	s - fpm (m/min)	7,5 - 72.83 (22,2)	
- Unladen retracting	s - fpm (m/min)	4,5 - 118.11 (36)	
- Laden retracting	s - fpm (m/min)	4,6 - 115.49 (35,2)	
Tilting movements			
- Unladen digging	s - °/s	3,4 - 42,9	
- Unladen discharging	s - °/s	2,8 - 52,1	

<b>SPECIFICATIONS AND WEIGHTS</b>			
Speed of movement for lift truck in standard configuration on flat ground (except in specific conditions)			
- Front unladen	1	mph (km/h)	2.73 (4,4)
	2	mph (km/h)	4.60 (7,4)
	3	mph (km/h)	9.32 (15)
	4	mph (km/h)	16.40 (26,4)
- Rear unladen	1	mph (km/h)	2.73 (4,4)
	2	mph (km/h)	4.60 (7,4)
	3	mph (km/h)	9.32 (15)
	4	mph (km/h)	16.40 (26,4)
Standard attachment		TFF 35 MT 1040	
- Weight of attachment (without forks)	lbs (kg)	363.76 (165)	
- Weight of forks (each)	lbs (kg)	148.81 (67,5)	
Rated capacity with standard attachment		lbs (kg)	
Tipping load at maximum reach on tires		lbs (kg)	
Distance from the centre of gravity of the load to the base of the forks		in (mm)	
Standard lifting height		in (mm)	
Lift truck weight without attachment		lbs (kg)	
Weight of lift truck with standard attachment			
- Unladen	lbs (kg)	14770.97 (6700)	
- At rated load	lbs (kg)	22046.23 (10000)	
Weight per axle with standard attachment (transport position)			
- Front unladen	lbs (kg)	7253.20 (3290)	
- Rear unladen	lbs (kg)	7517.76 (3410)	
- Front rated load	lbs (kg)	19246.36 (8730)	
- Rear rated load	lbs (kg)	2799.87 (1270)	
Weight per axle with standard attachment (boom extended)			
- Front rated load	lbs (kg)	15895.33 (7210)	
- Rear rated load	lbs (kg)	1300.72 (590)	
Drag strain on the coupling hook			
- Unladen (sliding)	lbf (daN)	12386.97 (5510)	
- At rated load (transmission setting)	lbf (daN)	18794.03 (8360)	
Break-out force with bucket (according to standard ISO 8313)		lbf (daN)	
		12971.48 (5770)	

<b>ENGINE</b>		
Type		DEUTZ TD3.6L/2501-2848
Fuel		Diesel
Number of cylinders		4 in line
Suction		Supercharged
Injection system		Direct
Ignition sequence		1.3.4.2
Capacity	cu.in (cm <sup>3</sup> )	221 (3621)
Bore and stroke	in (mm)	3.86 x 4.72 (98 x 120)
Compression ratio		18:1
Nominal speed laden	rpm	2200
Min. rpm unladen	rpm	930
Max. rpm unladen	rpm	2360
Power ISO/TR 14396	hp - kW	75 - 55,4
Power SAE J 1995	hp - kW	75 - 55,4
Maximum torque ISO/TR 14396	ft-lbs (Nm)	250.77 (340) to 1600 rpm
Air filtration efficiency	%	99,9
Type of cooling		By water
Fan		Puller
<b>TRANSMISSION</b>		
Gearbox		TURNER
- Type		Mechanical
- Reversing shift		Electro-hydraulic
- Torque converter		SACHS
- Number of forward speeds		4
- Number of reverse speeds		4
Angle gear box		TURNER
Front axle		DANA
- Differential		Limited slip
Rear axle		DANA
- Differential		Without locking
Drive wheels		Permanent 4 WD
- 2/4 wheel drive control		No
Front tyres		ALLIANCE
- Size		400/80-24 A325 162A8 ATG
- Pressure	psi (bar)	43.5 (3)
Rear tyres		ALLIANCE
- Size		400/80-24 A325 162A8 ATG
- Pressure	psi (bar)	43.5 (3)
<b>ELECTRIC CIRCUIT</b>		
Battery	STANDARD OPTION	12 V - 180 Ah - 900 A EN 12 V - 180 Ah - 1235 A EN
Alternator		14V - 95 A
- Type		ISKRA AAK3869
Starter		12 V - 3,2 kW
- Type		ISKRA AZE4668
<b>BRAKE SYSTEM</b>		
Service brake		Hydraulic power brake
- Type of brake		Oil-immersed multi-disc brake
- Type of control		Foot-operated for the front and rear axles
Parking brake		Mechanical
- Type of brake		Disk on gear-box output
- Type of control		Manual
<b>SOUND AND VIBRATION</b>		
Sound pressure level in the driver's cab LpA (according to standard NF EN 12053)	dB(A)	79 (cab closed); xx (cab open)
Sound pressure (according to Directive 2009/76)	dB(A)	xx (cab closed); xx (cab open)
Sound pressure level ensured in the LwA environment (according to Directive 2000/14/EC modified by Directive 2005/88/EC)	dB(A)	104 (measured); 104 (guaranteed)
Sound level in motion (according to Directive 2009/63)	dB(A)	xx
Average weighted acceleration on driver's body (according to standard NF EN 13059)	fps <sup>2</sup> (m/s <sup>2</sup> )	3.61 (1,1)
The average weighted acceleration transmitted to the driver's hand/ arm system (according to standard ISO 5349-2)	fps <sup>2</sup> (m/s <sup>2</sup> )	< 8.2 (< 2,5)
Standard seat vibration	fps <sup>2</sup> (m/s <sup>2</sup> )	xx (lightweight operator); xx (heavyweight operator)

<b>HYDRAULIC CIRCUIT</b>			
Hydraulic pump		Gear pump with flow divider	
- Type		1st casing	2nd casing
- Capacity	cu.in (cm <sup>3</sup> )	2.38 (39)	1.28 (21)
- Max. rating capacity unladen	gpm (L/min)	24.57 (93)	13.21 (50)
- Flow rate at 1,600 rpm	gpm (L/min)	16.64 (63)	8.99 (34)
Filtration			
- Return	mil (µm)	0.39 (10)	
- Suction	mil (µm)	4.92 (125)	
Maximum service pressure		3771 (260)	
- Telescoping circuit	psi (bar)	2755.7 (190) / 3771 (260)	
- Lifting circuit	psi (bar)	3771 (260) / 3771 (260)	
- Tilting circuit	psi (bar)	3771 (260) / 2755.7 (190)	
- Attachment circuit (OPTION)	psi (bar)	3771 (260)	
- Steering circuit	psi (bar)	2030.5 (140)	

<b>HYDRAULIC MOVEMENTS</b>			
Lifting motions (boom retracted)			
- Unladen lifting	s - fpm (m/min)	7,8 - 113.52 (34,6)	
- Laden lifting	s - fpm (m/min)	9 - 98.43 (30)	
- Unladen lowering	s - fpm (m/min)	6,3 - 140.75 (42,9)	
- Laden lowering	s - fpm (m/min)	6,4 - 138.45 (42,2)	
Telescoping motions (boom raised)			
- Unladen extending	s - fpm (m/min)	14,5 - 74.15 (22,6)	
- Laden extending	s - fpm (m/min)	13,8 - 70.54 (21,5)	
- Unladen retracting	s - fpm (m/min)	9,4 - 108.92 (33,2)	
- Laden retracting	s - fpm (m/min)	7,2 - 142.06 (43,3)	
Tilting movements			
- Unladen digging	s - °/s	3,4 - 42,9	
- Unladen discharging	s - °/s	2,9 - 50,3	

<b>SPECIFICATIONS AND WEIGHTS</b>			
Speed of movement for lift truck in standard configuration on flat ground (except in specific conditions)			
- Front unladen	1	mph (km/h)	2.73 (4,4)
	2	mph (km/h)	4.60 (7,4)
	3	mph (km/h)	9.32 (15)
	4	mph (km/h)	16.40 (26,4)
- Rear unladen	1	mph (km/h)	2.73 (4,4)
	2	mph (km/h)	4.60 (7,4)
	3	mph (km/h)	9.32 (15)
	4	mph (km/h)	16.40 (26,4)
Standard attachment		TFF 35 MT 1040	
- Weight of attachment (without forks)	lbs (kg)	363.76 (165)	
- Weight of forks (each)	lbs (kg)	148.81 (67,5)	
Rated capacity with standard attachment		lbs (kg)	
Tipping load at maximum reach on tires		lbs (kg)	
Distance from the centre of gravity of the load to the base of the forks		in (mm)	
Standard lifting height		in (mm)	
Lift truck weight without attachment		lbs (kg)	
Weight of lift truck with standard attachment			
- Unladen	lbs (kg)	15807.14 (7170)	
- At rated load	lbs (kg)	23082.40 (10470)	
Weight per axle with standard attachment (transport position)			
- Front unladen	lbs (kg)	7650.04 (3470)	
- Rear unladen	lbs (kg)	8157.10 (3700)	
- Front rated load	lbs (kg)	19577.05 (8880)	
- Rear rated load	lbs (kg)	3505.35 (1590)	
Weight per axle with standard attachment (boom extended)			
- Front rated load	lbs (kg)	15873.28 (7200)	
- Rear rated load	lbs (kg)	925.94 (420)	
Drag strain on the coupling hook			
- Unladen (sliding)	lbf (daN)	11307.89 (5030)	
- At rated load (transmission setting)	lbf (daN)	17804.87 (7920)	
Break-out force with bucket (according to standard ISO 8313)		lbf (daN)	
		12971.48 (5770)	

## TYRES

MT 733...		PRESSURE psi (bar)	LOAD PER TIRE lbs (kg)			
			FRONT UNLADEN	FRONT LADEN	REAR UNLADEN	REAR LADEN
ALLIANCE	400/80-24 A325 162A8 ATG	43.5 (3)	3638 (1650)	9590 (4350)	3748 (1700)	1433 (650)
MICHELIN	400/80-24 162A8 IND TL PCL	43.5 (3)				
	15,5R25 XHA TUBELESS	50.8 (3,5)				
	460/70 R24 159A8/159B IND TL BIBLOAD HARD SURFACE	49.3 (3,4)				
APOLLO	400/80-24 20PR 162A8 TL FX525	58 (4)				

		PRESSURE psi (bar)	LOAD lbs (kg)	GROUND CONTACT PRESSURE psi (kg/cm <sup>2</sup> )		GROUND CONTACT AREA in <sup>2</sup> (cm <sup>2</sup> )		
				HARD GROUND	SOFT GROUND	HARD GROUND	SOFT GROUND	
ALLIANCE	400/80-24 A325 162A8 ATG	43.5 (3)	1433 (650)					
			3638 (1650)					
			3748 (1700)					
			9590 (4350)					
MICHELIN	400/80-24 162A8 IND TL PCL	43.5 (3)	1433 (650)	29.6 (2,08)	8 (0,56)	50.8 (328)	189.4 (1222)	
			3638 (1650)	35.3 (2,48)	14.9 (1,05)	102.9 (664)	243.5 (1571)	
			3748 (1700)	35.6 (2,50)	15.2 (1,07)	105.4 (680)	246.3 (1589)	
			9590 (4350)	43.2 (3,04)	24.3 (1,71)	220.6 (1423)	390 (2516)	
	15,5R25 XHA TUBELESS	50.8 (3,5)	1433 (650)	57.3 (4,03)	32.3 (2,27)	26.2 (169)	46 (297)	
			3638 (1650)	68.4 (4,81)	36.1 (2,54)	53.2 (343)	100.7 (650)	
			3748 (1700)	68.8 (4,84)	36.3 (2,55)	54.4 (351)	103.4 (667)	
	460/70 R24 159A8/159B IND TL BIBLOAD HARD SURFACE	49.3 (3,4)	9590 (4350)	79.5 (5,59)	41.1 (2,89)	120 (774)	232 (1497)	
			1433 (650)					
			3638 (1650)					
	APOLLO	400/80-24 20PR 162A8 TL FX525	4	3748 (1700)				
				9590 (4350)				
1433 (650)								
3638 (1650)								

MT 933...		PRESSURE psi (bar)	LOAD PER TIRE lbs (kg)			
			FRONT UNLADEN	FRONT LADEN	REAR UNLADEN	REAR LADEN
ALLIANCE	400/80-24 A325 162A8 ATG	43.5 (3)	3858 (1750)	9811 (4450)	4079 (1850)	1764 (800)
MICHELIN	400/80-24 162A8 IND TL PCL	43.5 (3)				
	15,5R25 XHA TUBELESS	50.8 (3,5)				
	460/70 R24 159A8/159B IND TL BIBLOAD HARD SURFACE	49.3 (3,4)				
APOLLO	400/80-24 20PR 162A8 TL FX525	58 (4)				

		PRESSURE psi (bar)	LOAD lbs (kg)	GROUND CONTACT PRESSURE psi (kg/cm2)		GROUND CONTACT AREA in2 (cm2)	
				HARD GROUND	SOFT GROUND	HARD GROUND	SOFT GROUND
ALLIANCE	400/80-24 A325 162A8 ATG	43.5 (3)	1764 (800)				
			3858 (1750)				
			4079 (1850)				
			9811 (4450)				
MICHELIN	400/80-24 162A8 IND TL PCL	43.5 (3)	1764 (800)	30.4 (2,14)	9.1 (0,64)	58.6 (378)	197.5 (1274)
			3858 (1750)	35.7 (2,51)	15.5 (1,09)	107.9 (696)	248.9 (1606)
			4079 (1850)	36.1 (2,54)	15.9 (1,12)	112.5 (726)	254.4 (1641)
			9811 (4450)	43.5 (3,06)	24.6(1,73)	224.7 (1450)	395.4 (2551)
	15,5R25 XHA TUBELESS	50.8 (3,5)	1764 (800)	59 (4,15)	32.9 (2,31)	30.2 (195)	54.3 (350)
			3858 (1750)	69.1 (4,86)	36.3 (2,55)	55.8 (360)	106.2 (685)
			4079 (1850)	69.7(4,90)	36.6 (2,57)	58.4 (377)	111.4 (719)
			9811 (4450)	79.9 (5,62)	41.4 (2,91)	122.3 (789)	236.7 (1527)
	460/70 R24 159A8/159B IND TL BIBLOAD HARD SURFACE	49.3 (3,4)	1764 (800)				
			3858 (1750)				
			4079 (1850)				
			9811 (4450)				
APOLLO	400/80-24 20PR 162A8 TL FX525	4	1764 (800)				
			3858 (1750)				
			4079 (1850)				
			9811 (4450)				

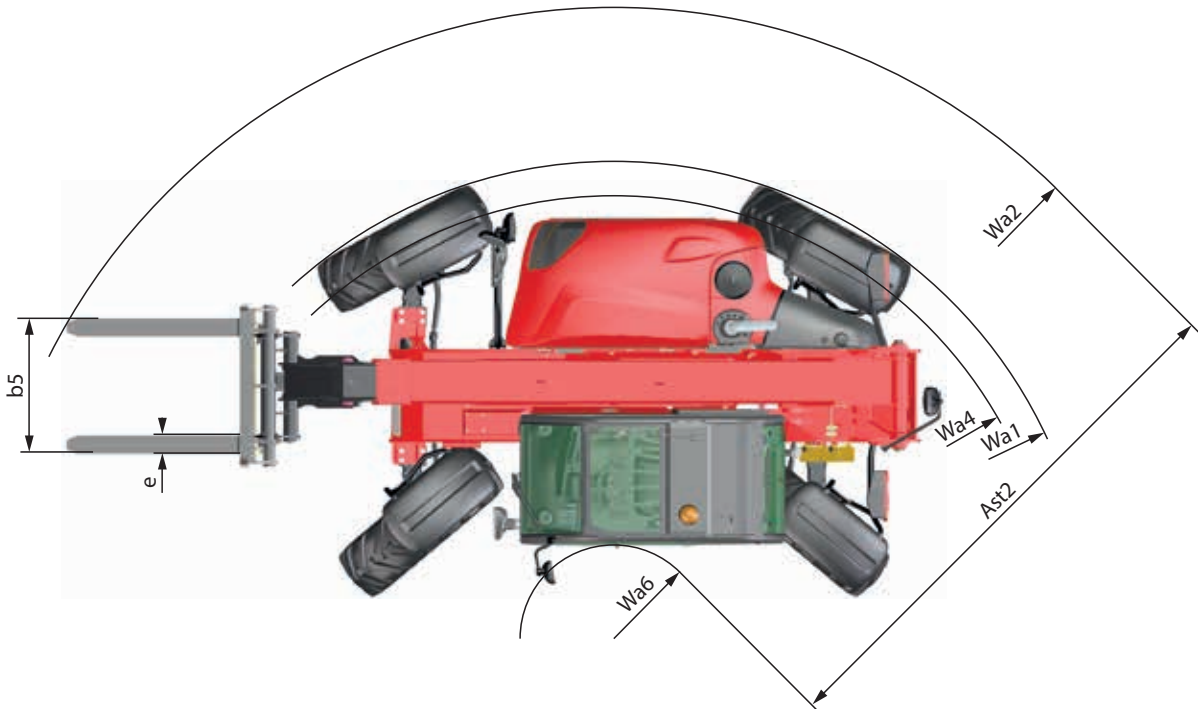
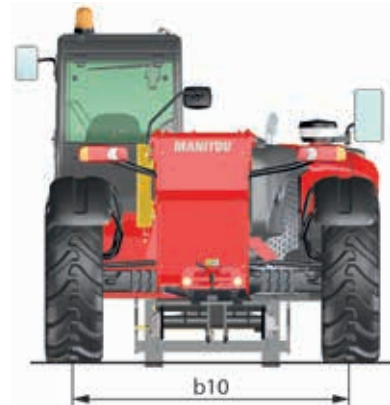
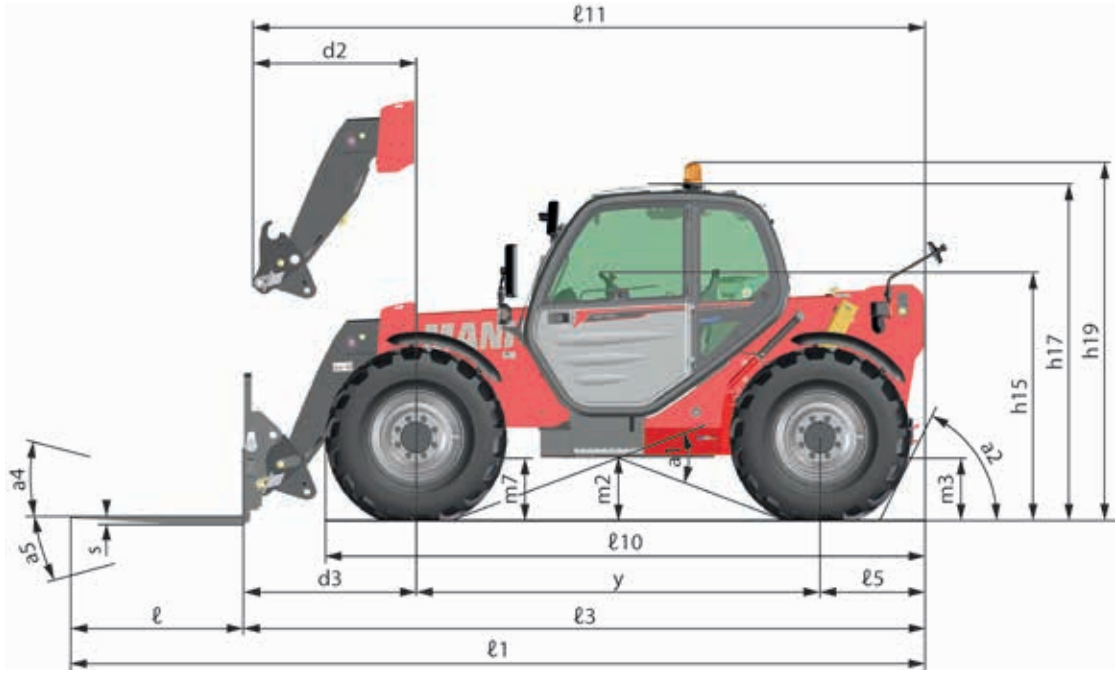

MACHINE LENGTH	<b>ℓ1</b>	in (mm)	233.43 (5929)
	<b>ℓ3</b>	in (mm)	186.18 (4729)
	<b>ℓ5</b>	in (mm)	28.54 (725)
	<b>ℓ10</b>	in (mm)	163.78 (4160)
	<b>ℓ11</b>	in (mm)	183.98 (4673)
MACHINE WIDTH	<b>b1</b>	in (mm)	91.89(2334)
	<b>b4</b>	in (mm)	35.04 (890)
	<b>b5</b>	in (mm)	40.94 (1040)
	<b>b9</b>	in (mm)	75.98 (1930)
	<b>b10</b>	in (mm)	75.98 (1930)
MACHINE HEIGHT	<b>h15</b>	in (mm)	67.60 (1717)
	<b>h17</b>	in (mm)	90.55 (2300)
	<b>h19</b>	in (mm)	98.43 (2500)
DISTANCE	<b>d2</b>	in (mm)	44.80 (1138)
	<b>d3</b>	in (mm)	47.01(1194)
AISLE WIDTH	<b>Ast2</b>	in (mm)	137.40 (3490)
ATTACHMENT	<b>ℓ</b>	in (mm)	47.24 (1200)
	<b>s</b>	in (mm)	1.77 (45)
	<b>e</b>	in (mm)	4.92 (125)
TURNING RADIUS	<b>Wa1</b>	in (mm)	149.61 (3800)
	<b>Wa2</b>	in (mm)	188.98 (4800)
	<b>Wa4</b>	in (mm)	141.65 (3598)
	<b>Wa6</b>	in (mm)	54.57 (1310)
GROUND CLEARANCE	<b>m2</b>	in (mm)	17.13 (435)
	<b>m3</b>	in (mm)	17.13 (435)
	<b>m7</b>	in (mm)	17.13 (435)
ANGLE	<b>a1</b>	°	38
	<b>a2</b>	°	64
	<b>a4</b>	°	12
	<b>a5</b>	°	114
WHEELBASE	<b>y</b>	in (mm)	110.63 (2810)

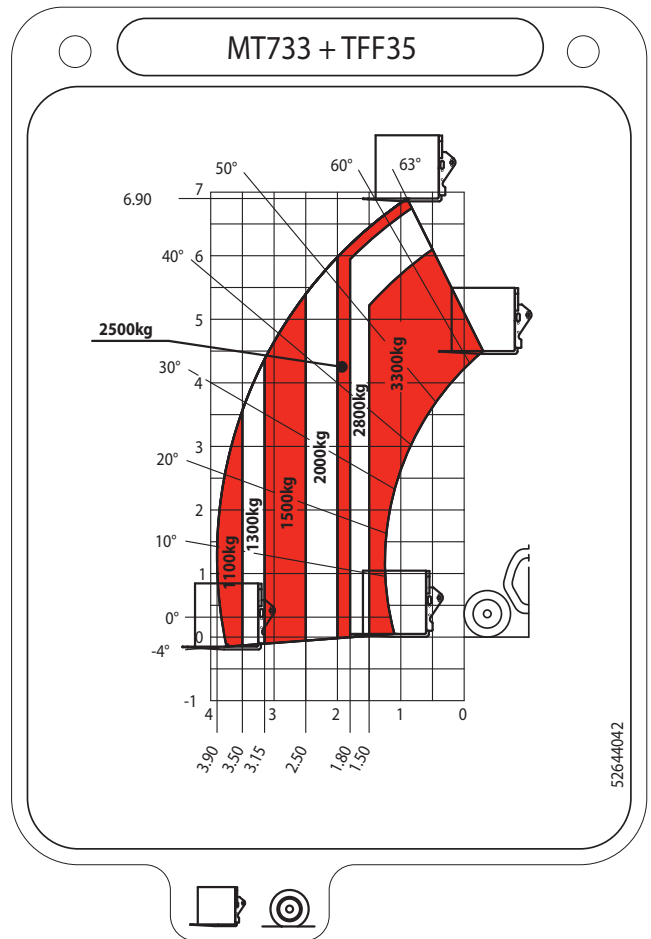

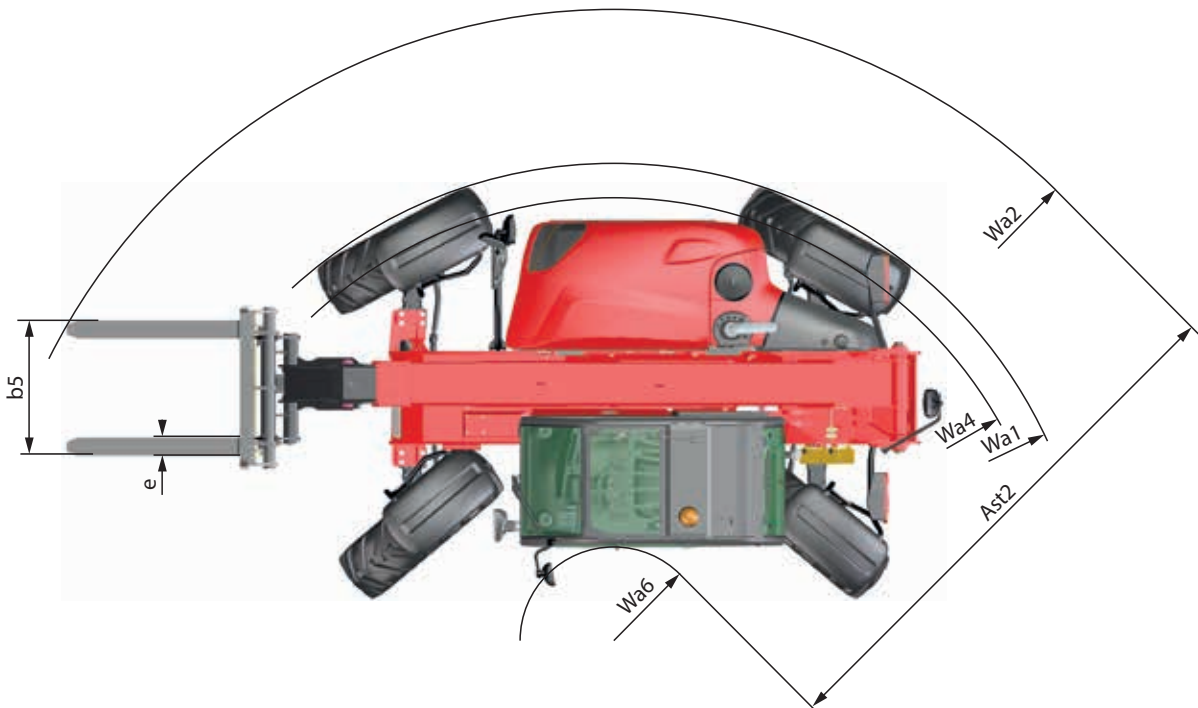
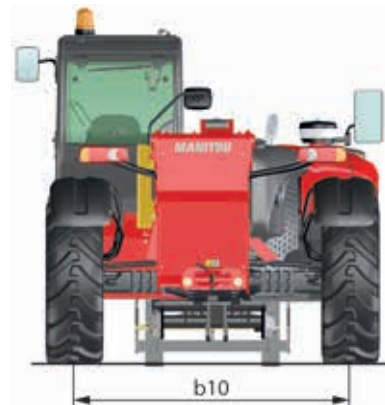
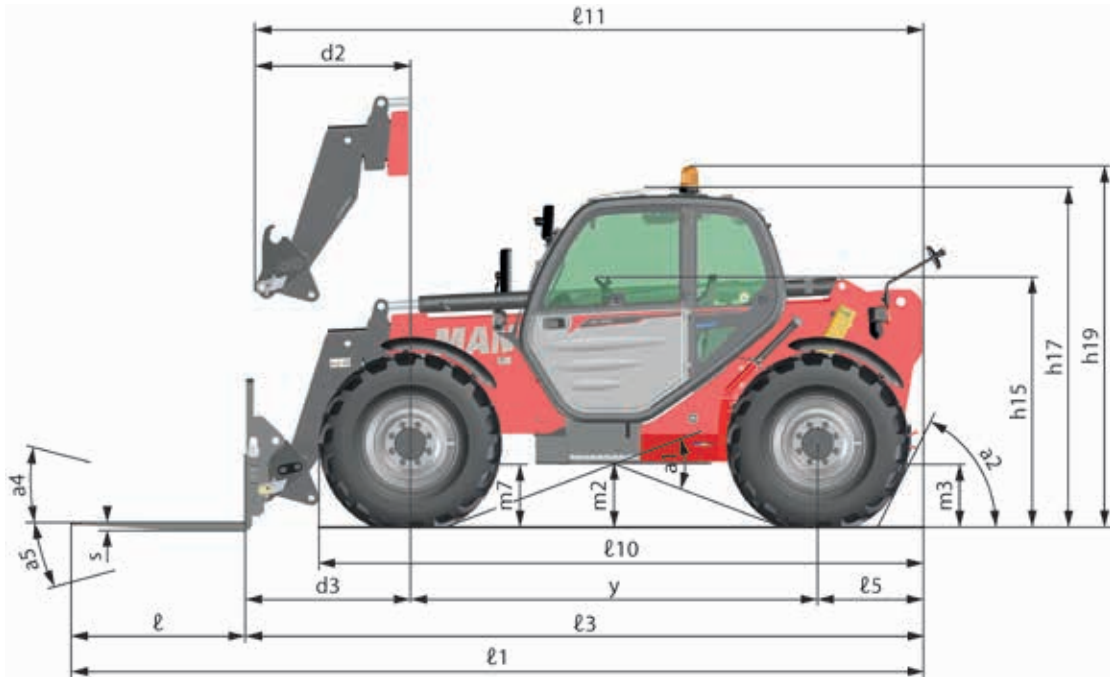

MACHINE LENGTH	<b>ℓ1</b>	in (mm)	231.42 (5878)
	<b>ℓ3</b>	in (mm)	184.17 (4678)
	<b>ℓ5</b>	in (mm)	28.54 (725)
	<b>ℓ10</b>	in (mm)	163.78 (4160)
	<b>ℓ11</b>	in (mm)	181.42 (4608)
MACHINE WIDTH	<b>b1</b>	in (mm)	91.89(2334)
	<b>b4</b>	in (mm)	35.04 (890)
	<b>b5</b>	in (mm)	40.94 (1040)
	<b>b9</b>	in (mm)	75.98 (1930)
	<b>b10</b>	in (mm)	75.98 (1930)
MACHINE HEIGHT	<b>h15</b>	in (mm)	67.60 (1717)
	<b>h17</b>	in (mm)	90.55 (2300)
	<b>h19</b>	in (mm)	98.43 (2500)
DISTANCE	<b>d2</b>	in (mm)	42.24 (1073)
	<b>d3</b>	in (mm)	45 (1143)
AISLE WIDTH	<b>Ast2</b>	in (mm)	136.22 (3460)
ATTACHMENT	<b>ℓ</b>	in (mm)	47.24 (1200)
	<b>s</b>	in (mm)	1.77 (45)
	<b>e</b>	in (mm)	4.92 (125)
TURNING RADIUS	<b>Wa1</b>	in (mm)	149.61 (3800)
	<b>Wa2</b>	in (mm)	187.80 (4770)
	<b>Wa4</b>	in (mm)	141.65 (3598)
	<b>Wa6</b>	in (mm)	54.57 (1310)
GROUND CLEARANCE	<b>m2</b>	in (mm)	17.13 (435)
	<b>m3</b>	in (mm)	17.13 (435)
	<b>m7</b>	in (mm)	17.13 (435)
ANGLE	<b>a1</b>	°	38
	<b>a2</b>	°	64
	<b>a4</b>	°	12
	<b>a5</b>	°	114
WHEELBASE	<b>y</b>	in (mm)	110.63 (2810)

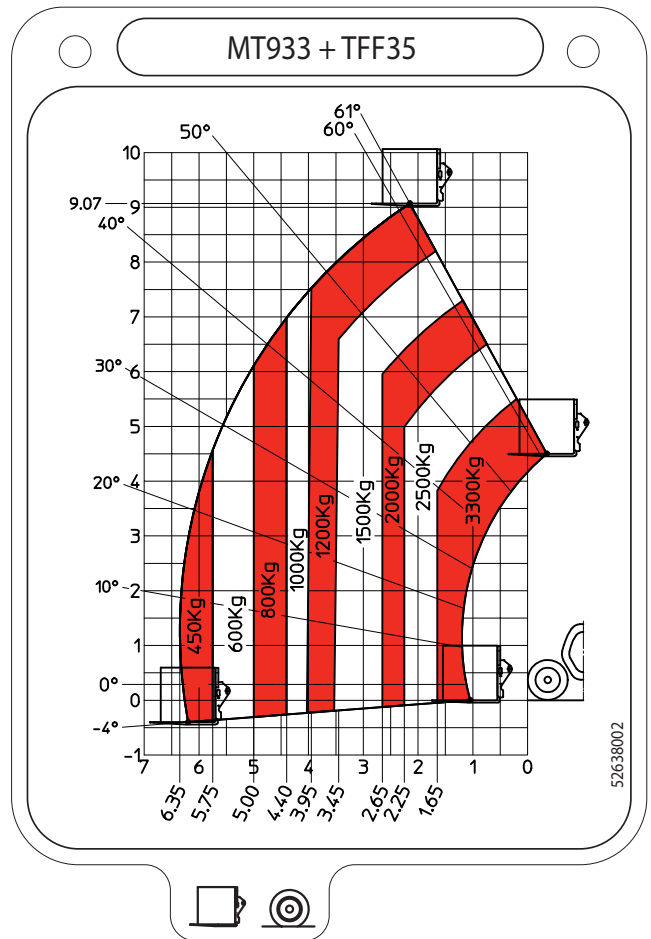

## VISIBILITY

We use European standard EN15830 relating to operator visibility.

- Adhere to the instructions for optimising operator visibility in the immediate vicinity (⇐ 1 - OPERATING AND SAFETY INSTRUCTIONS: INSTRUCTIONS TO THE OPERATOR: DRIVING INSTRUCTIONS UNLADEN AND LADEN: D - VISIBILITY).

### DESCRIPTION AND ADJUSTMENT OF REAR-VIEW MIRRORS

- 1 - LEFT REAR-VIEW MIRROR
- 2 - MAIN RIGHT REAR-VIEW MIRROR
- 3 - INSIDE REAR-VIEW MIRROR (OPTION)
- 4 - REAR-VIEW MIRROR

- Place the lift truck on level ground with the engine stopped, and the boom retracted and lowered as far as possible.
- Note the position of the reference points ●...○ in the illustrations, to see and correctly adjust the rear-view mirrors.

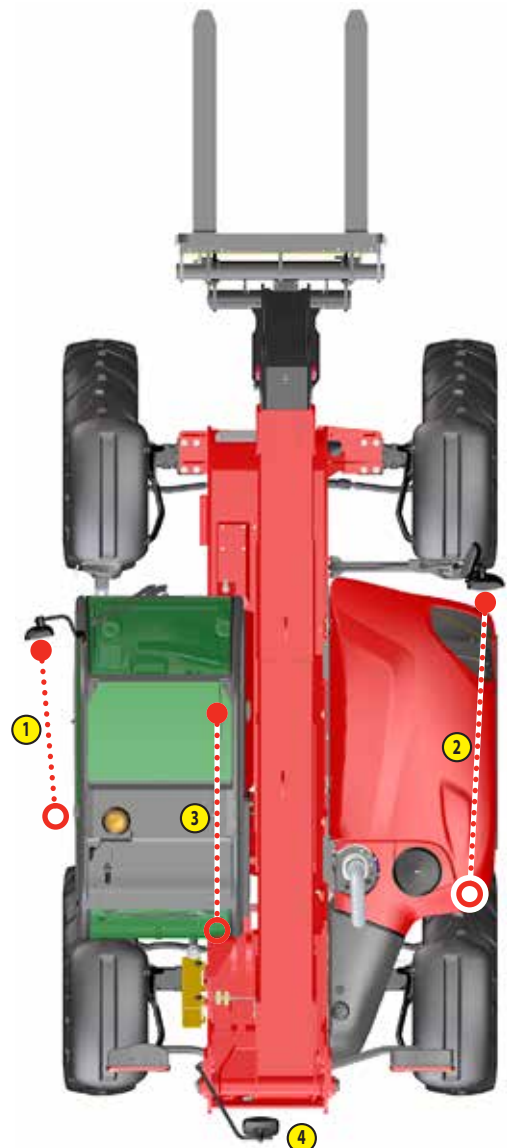
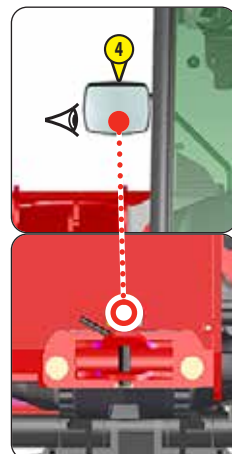
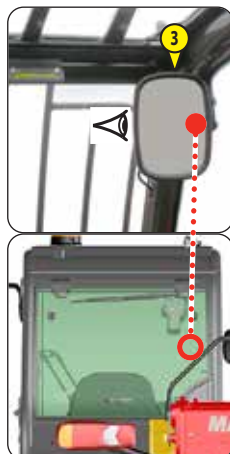
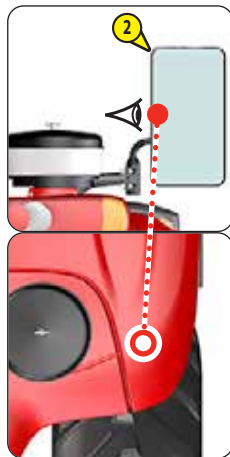
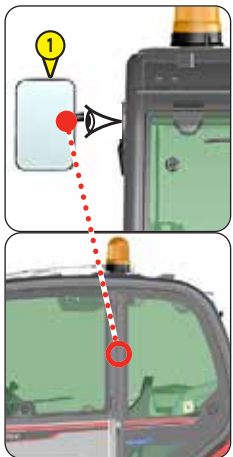



## INSTRUMENTS AND CONTROLS

### DESCRIPTION

NOTE: All the terms such as: RIGHT, LEFT, FRONT, REAR are as seen by an observer occupying the driver's seat and looking straight ahead.

1 - DRIVER'S CAB ACCESS .....	2-26
2 - DRIVER'S SEAT .....	2-26
3 - SEAT BELT .....	2-27
4 - IGNITION SWITCH .....	2-27
5 - EMERGENCY STOP .....	2-28
6 - CONTROL AND SIGNAL LIGHTS PANEL .....	2-28
7 - NOT USED .....	2-32
8 - SWITCHES .....	2-32
9 - LIGHTING, HORN AND INDICATOR SWITCH .....	2-34
10 - FRONT AND REAR WINDSCREEN WIPER SWITCH .....	2-34
11 - STEERING SELECTION .....	2-34
12 - FUSES AND RELAYS IN THE CAB .....	2-35
13 - FUSES AND RELAYS UNDER THE ENGINE COVER .....	2-36
14 - DIAGNOSTIC PLUG .....	2-37
15 - ACCELERATOR PEDAL .....	2-37
16 - SERVICE BRAKE PEDAL AND TRANSMISSION CUT-OFF .....	2-37
17 - GEAR LEVER AND TRANSMISSION CUT-OFF .....	2-37
18 - PARKING BRAKE LEVER .....	2-37
19 - FORWARD/NEUTRAL/REVERSE GEAR SELECTION .....	2-38
20 - HYDRAULIC CONTROLS .....	2-38
21 - FUNCTION FILES .....	2-39
22 - LEVEL INDICATOR .....	2-39
23 - HEATER CONTROL .....	2-40
24 - AIR CONDITIONING CONTROLS (AIR CONDITIONING OPTION) .....	2-40
25 - WINDSCREEN DEMISTER VENTS .....	2-40
26 - HEATING VENTS .....	2-40
27 - STEERING WHEEL ADJUSTMENT LEVER (OPTION) .....	2-41
28 - DOOR OPENING HANDLE .....	2-41
29 - LOCKING HANDLE FOR UPPER HALF-DOOR .....	2-41
30 - UNLOCKING BUTTON FOR UPPER HALF-DOOR .....	2-41
31 - HANDLE FOR REAR WINDOW OPENING .....	2-41
32 - STORAGE COMPARTMENT .....	2-41
33 - STORAGE NET .....	2-41
34 - SUN VISOR (OPTION) .....	2-42
35 - ROOF LIGHT .....	2-42
36 - HOOK .....	2-42
37 - INSIDE REAR-VIEW MIRROR (OPTION) .....	2-42
38 - ARMREST .....	2-42
39 - 12V SOCKET .....	2-42
40 - BATTERY CUT-OFF .....	2-43
41 - FRONT HEADLIGHTS .....	2-43
42 - REAR LIGHTS .....	2-43
43 - ROTATING BEACON LIGHT .....	2-43
44 - BOOM SAFETY WEDGE .....	2-44
45 - FUEL TANK .....	2-44

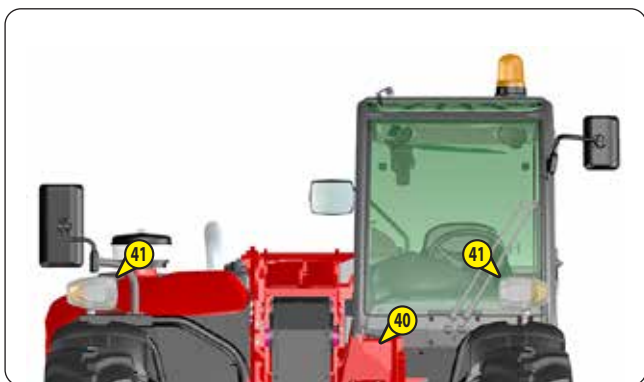
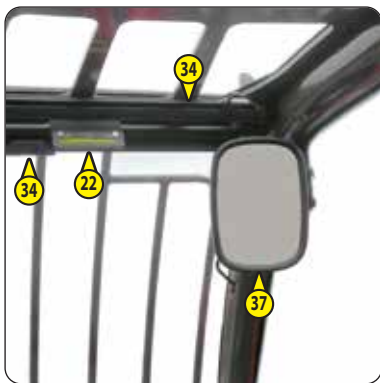
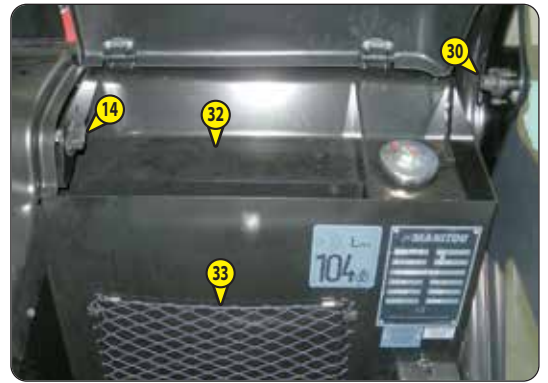
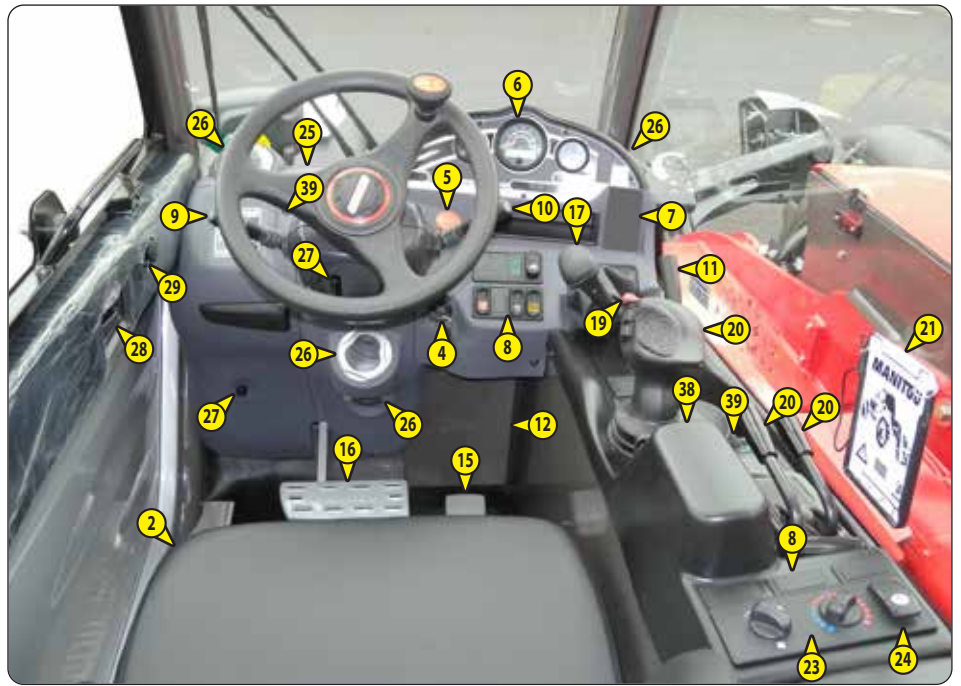

## 1 - DRIVER'S CAB ACCESS

- Face the driver's cab access to get in and out, and always use the three support points provided for this purpose.
  - 1 - Left handle.
  - 2 - Right handle.
  - 3 - Step.



## 2 - DRIVER'S SEAT

### DRIVER'S SEAT (STANDARD)

DESIGNED FOR MAXIMUM COMFORT, THIS SEAT CAN BE ADJUSTED AS FOLLOWS.

#### LONGITUDINAL ADJUSTMENT

- Unlock the locking lever 1.
- Slide the seat to the desired position.
- Release the lever and be sure it returns to the lock position.

#### SEAT HEIGHT ADJUSTMENT

- Sit down correctly in the seat.
- Turn the knob 2 according to the desired height, clockwise to raise, anti-clockwise to lower.

#### SEAT SUSPENSION ADJUSTMENT

- Make sure that the indicator 3 is in the green zone.

#### BACKREST ANGLE ADJUSTMENT

- Hold the backrest, push the lever 4 backwards and tilt the backrest to the desired position.



*If you do not support the backrest when making adjustments, it swings completely forwards.*

### DRIVER'S SEAT (OPTION)

DESIGNED FOR MAXIMUM COMFORT, THIS SEAT CAN BE ADJUSTED AS FOLLOWS.

#### SEAT HEIGHT ADJUSTMENT

- Sit down correctly in the seat.
- Turn the knob 1 according to the desired height, clockwise to raise, anti-clockwise to lower, ensuring that the green indicator lamp 2 remains visible.
- If indicator lamp 2 is red, re-adjust the height.

NOTE: The seat is designed so as not to require adjustment according to the driver's weight.

#### LONGITUDINAL ADJUSTMENT

- Pull lever 3 upwards.
- Slide the seat to the desired position.
- Release the lever and be sure it returns to the lock position.

#### BACKREST ANGLE ADJUSTMENT

- Hold the backrest, push the lever 4 backwards and tilt the backrest to the desired position.



*If you do not support the backrest when making adjustments, it swings completely forwards.*

#### HEADREST

- The height of the headrest 5 can be adjusted by pulling it upwards (the notches will click) up to the stop.
- The headrest can be removed by applying sufficient pressure to pull it off the stop.

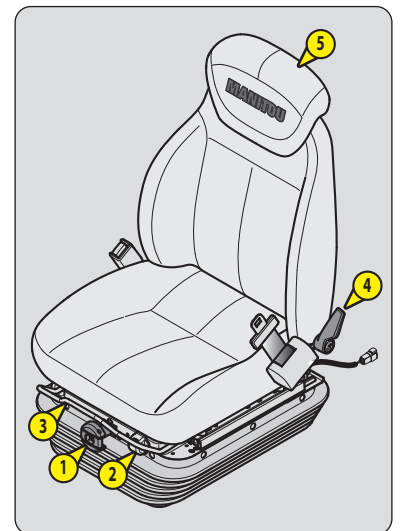

## DRIVER'S PNEUMATIC SEAT (OPTION)

MT 733...

DESIGNED FOR MAXIMUM COMFORT, THIS SEAT CAN BE ADJUSTED AS FOLLOWS.

### **SEAT HEIGHT ADJUSTMENT**

- Sit down correctly in the seat.
- Switch on lift truck ignition.
- Pull or push lever 1 according to the desired height, making sure that the green indicator lamp 2 remains visible.
- If indicator lamp 2 is red, re-adjust the height.

NOTE: The seat is designed so as not to require adjustment according to the driver's weight.

### **LONGITUDINAL ADJUSTMENT**

- Swing lever 3 upwards.
- Slide the seat to the desired position.
- Release the lever and be sure it returns to the lock position.

### **HORIZONTAL SHOCK ABSORBER**

In certain conditions (e.g. driving with a trailer) it is advised that a horizontal shock absorber be used. The driver's seat is thus better able to absorb jerks in the direction of travel.

- Swing lever 3 downwards to block the horizontal damper.

### **BACKREST ANGLE ADJUSTMENT**

- Hold the backrest, push the lever 4 backwards and tilt the backrest to the desired position.



*If you do not support the backrest when making adjustments, it swings completely forwards.*

### **HEADREST**

- The height of the headrest 5 can be adjusted by pulling it upwards (the notches will click) up to the stop.
- The headrest can be removed by applying sufficient pressure to pull it off the stop.

### **LUMBAR ADJUSTMENT**

- Turn knob 6 anti-clockwise to select one of the 5 lumbar support settings.

### **SEAT HEATING**

- Switch 7 operates the heating of the seat cushion and the backrest.

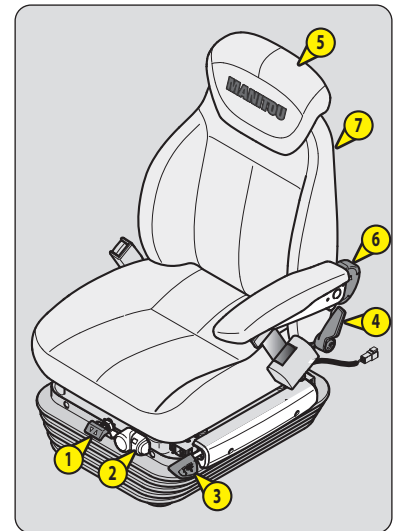

## 3 - SEAT BELT



*Under no circumstances must the lift truck be used if the seat belt is defective (fixing, locking, cuts, tears, etc.).  
Immediately repair or replace the seat belt.*

- Sit correctly on the seat.
- Check that seat belt is not twisted.
- Place the seat belt at hip level.
- Attach the seat belt and check that it locks.
- Adjust the seat belt to your body shape without compressing your pelvis and without excessive slack.

## 4 - IGNITION SWITCH

This switch has 5 positions:

- P - Not used.
- O - Ignition switched off and engine stopped.
- I - Ignition + preheat.
- II - Not
- III - Start-up and returns to position I as soon as the key is released.

## 5 - EMERGENCY STOP

In the event of danger, it enables the engine to be shut down, thereby cutting-off all hydraulic movements.

### ⚠ IMPORTANT ⚠

*Be ready for hydraulic movements suddenly stopping when you press this button.  
If possible stop the lift truck before using the emergency stop button.*

- Turn switch to disable.



## 6 - CONTROL AND SIGNAL LIGHTS PANEL

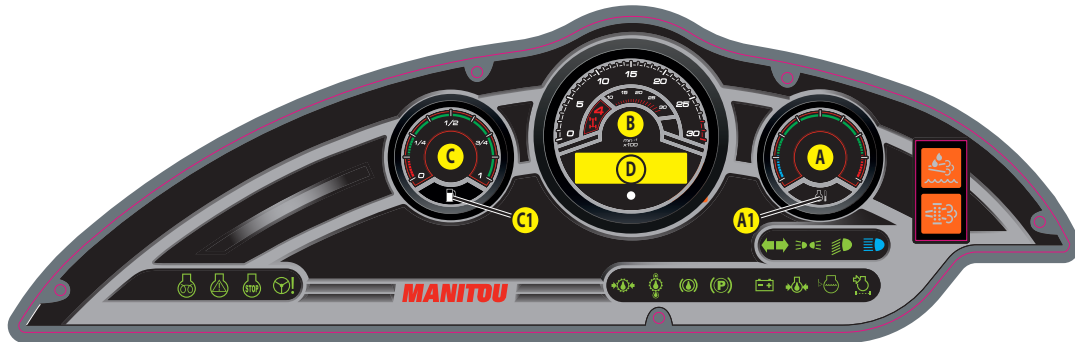

### ⚠ IMPORTANT ⚠

*A permanently lit or flashing warning lamp, with the engine running, is the sign of an operating fault.  
The lighting of some lamps may be accompanied by an audible signal. Do not ignore this warning, consult your dealer without delay.  
If one of the warning lamps comes on while the lift truck is in motion, stop the lift truck under the safest possible conditions.*

When activating the electrical system of the lift truck, all the red and orange lamps and the panel's buzzer must light to indicate their good working order. If one of the red lamps or the buzzer does not function, carry out the necessary repairs.

### A - ENGINE WATER TEMPERATURE





If indicator lamp A1 comes on when the lift truck is running, this means that the coolant temperature is high. Stop the engine immediately and seek the cause of the cooling system malfunction.

### B - REV COUNTER

### C - FUEL LEVEL

Indicator lamp C1 indicates that you are in reserve and that your running time is limited.

### D - SCREEN DISPLAYS

- Turn on the lift truck ignition using the ignition key.
- The  initialisation screen appears, please wait.
- The  screen appears to show:
  - The direction of travel (F for forward/R for reverse/N for neutral).
  - The hour meter.
  - The clock.
- Short press  button A to move successively from one screen to another, hold down the button  to enter the menus.



Main screen.	.....➔	To set the time, short press to increment the value or hold down to move to the next number.	.....➔
Daily hour meter screen.	.....➔	Reset to zero.	
Engine fault screen.	.....➔	Fault code display.	
ECU fault screen.	.....➔	Fault code display.	
Instantaneous consumption screen.			
Countdown to next regeneration screen (700h => 0h).			
Main screen.			

#### HELP SCREENS



FanOff



FanOn

Self-cleaning fan, these screens are displayed for 3 seconds.

#### WARNING SCREENS



Water

This screen is displayed for 3 seconds every 10 minutes in the event that there is water in the diesel. Drain the fuel pre-filter (↙ 3 - MAINTENANCE: 10H - DAILY OR EVERY 10 HOURS OF SERVICE).



#### ENGINE PREHEAT INDICATOR LAMP

Preheat is necessary. When the lift truck is switched on, the indicator lamp comes on for 2 seconds and goes off as soon as preheat is ended. Start the lift truck's engine.



#### ENGINE FAULT INDICATOR LAMP

If the indicator lamp comes on or flashes while the lift truck is in operation, a diagnostic fault has been detected. The lift truck will operate in reduced mode. Consult your dealer without delay.



#### CUT-OFF ENGINE INDICATOR LAMP

If the indicator lamp lights up or flashes, when the lift truck is running, stop the engine immediately and consult your dealer.



#### STEERING SYSTEM OIL PRESSURE WARNING INDICATOR LAMP

If the indicator lamp lights up when the lift truck is running, stop the engine immediately and determine the cause (possible leak, etc.).



### **GEAR BOX OIL PRESSURE WARNING INDICATOR LAMP**

The indicator lamp and buzzer come on when there is an abnormal drop in gear box pressure, in forward gear. Stop the engine and determine the cause (gear box oil level, possible leak, radiator, etc.).

NOTE: This indicator lamp operates in forward travel conditions only, and can be ignored when the lift truck is stopped with the engine running at min rpm.



### **GEAR BOX OIL TEMPERATURE WARNING INDICATOR LAMP**

The indicator lamp and buzzer come on when the gear box oil temperature is abnormally high. Stop the engine and determine the cause (gear box oil level, possible leak, radiator, etc.).



### **BRAKE FLUID LEVEL WARNING INDICATOR LAMP**

If the indicator lamp and buzzer come on, when the lift truck is running, stop the engine immediately and determine the cause (braking oil level, possible leak, etc.). In the event of an abnormal drop in the level, consult your dealer.



### **PARKING BRAKE INDICATOR LAMP**

This indicator lamp comes on when the parking brake is applied.



### **BATTERY CHARGE WARNING INDICATOR LAMP**

If the indicator lamp and buzzer come on when the lift truck is running, stop the engine immediately and determine the cause (electric circuit, alternator belt, alternator, etc.).



### **ENGINE OIL PRESSURE WARNING INDICATOR LAMP**

If the indicator lamp comes on when the forklift truck is operating, stop the engine immediately and look for the cause (see oil level in engine crankcase).

NOTE: After starting the engine, the indicator lamp remains lit for a few seconds then goes out when the correct engine oil pressure is reached. The full engine power is then available.



### **ENGINE WATER LEVEL WARNING INDICATOR LAMP**

If the indicator lamp and buzzer come on when the lift truck is running, stop the engine immediately and determine the cause (coolant level, possible leak, radiator, etc.).



### **AIR FILTER OR HYDRAULIC RETURN FILTER CLOGGING WARNING INDICATOR LAMP**

The indicator lamp and the buzzer come on when the air filter cartridge or the hydraulic return oil filter cartridge is clogged. Stop the engine and carry out the necessary repairs (↩ 3 - MAINTENANCE: FILTER CARTRIDGES AND BELTS).



### **INDICATOR LIGHTS INDICATOR LAMP**



### **SIDELIGHTS INDICATOR LAMP**



### **LOW BEAM INDICATOR LAMP**



### **MAIN BEAM INDICATOR LAMP**



## EXHAUST DECONTAMINATION SYSTEM WARNING INDICATOR LAMP







The indicator lamp comes on if the system efficiency is defective. Contact your dealer.



## SOOT LEVEL

If the indicator lamp comes on while the lift truck is operating, perform a "STATIONARY LIFT TRUCK" EXHAUST REGENERATION (<math>\leq 3</math> - MAINTENANCE; OCCASIONAL MAINTENANCE).

The indicator lamp also comes on when the count (700h => 0h) before next regeneration has elapsed.

Flashing indicator lamp 	- Perform "STATIONARY LIFT TRUCK" EXHAUST REGENERATION.
Fixed  indicator lamp + long audible signal.	- Perform "STATIONARY LIFT TRUCK" EXHAUST REGENERATION.
Fixed  indicator lamp +  + short audible signal.	- Reduced lift truck efficiency, perform "STATIONARY LIFT TRUCK" EXHAUST REGENERATION.
Fixed  indicator lamp +  + short audible signal.	<b><i>Reduced lift truck efficiency, shut down the lift truck and contact your dealer.</i></b>

8 - SWITCHES

The location of the switches may vary depending on the options.

 **BOOM ELECTRICAL PREDISPOSITION (OPTION)**

< DESCRIPTION AND USE OF THE OPTIONS

 **BOOM HEAD ELECTROVALVE (OPTION)**

< DESCRIPTION AND USE OF THE OPTIONS

 **HAZARD WARNING LIGHTS**

 **REAR FOG LIGHTS**

 **SELF-CLEANING FAN (OPTION)**

< DESCRIPTION AND USE OF THE OPTIONS

 **STEERING SELECTION**

 **TRANSMISSION CUT-OFF**

NOTE: In all cases transmission cut-off can be activated using the gear lever.

- Position 1: Indicator lamp is on, transmission is cut off with the service brake pedal and the forward/neutral/reverse gear lever.
- Position 2: Indicator lamp is off, transmission is cut off with the forward/neutral/reverse gear selector.

USE OF TRANSMISSION CUT-OFF

- Transmission cut-off to brake pedal (position 1).
  - When loading.
- Transmission cut-off with forward/neutral/reverse gear selector (position 2).
  - When driving.
  - For inching and continuous stop/start (delicate handling).
  - Start-up on a slope.



 **ROTATING BEACON LIGHT**

 **FRONT WORKING LIGHTS (OPTION)**

 **REAR WORKING LIGHTS (OPTION)**

 **FRONT AND REAR WORKING LIGHTS (OPTION)**

 **BOOM HEAD WORKING LIGHTS (OPTION)**

 **REAR WINDOW DEFROSTER (OPTION)**

 **ROOF WINDSCREEN WIPER + SIDE WINDSCREEN WIPER (OPTION)**





### **ATTACHMENT EASY HYDRAULIC CONNECTION (OPTION)**

< DESCRIPTION AND USE OF THE OPTIONS



### **BOOM SUSPENSION (OPTION)**

< DESCRIPTION AND USE OF THE OPTIONS



### **EXHAUST REGENERATION**

< 3 - MAINTENANCE: OCCASIONAL MAINTENANCE



### **OPTION**



### **GREEN ROTATING BEACON LIGHT (OPTION)**



### **ATTACHMENT HYDRAULIC LOCKING (OPTION)**

< DESCRIPTION AND USE OF THE OPTIONS



### **HYDRAULIC MOVEMENT NEUTRALISATION**

When driving on the road, it is highly recommended (mandatory in Germany) that you cut off all the hydraulic movements. The indicator lamp shows when it is in use.



## 9 - LIGHTING, HORN AND INDICATOR SWITCH

The switch controls the visual and sound alarms.

- A - All lights are off, the indicator lights do not flash.
- B - The right hand indicator lights flash.
- C - The left hand indicator lights flash.
- D - Sidelights and rear lights on.
- E - The dipped headlights and the rear lights are on.
- F - The main beam headlights and the rear lights are on.
- G - Headlight signalling.

Pressing the end of the switch sounds the horn.

NOTE: Positions D - E - F - G can be used without switching on the ignition.

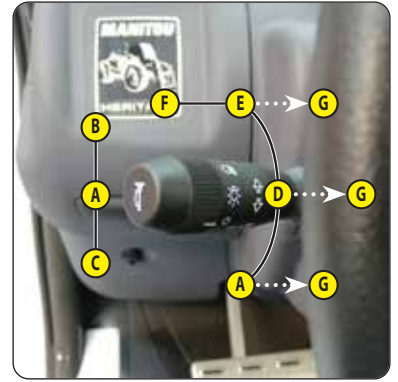

## 10 - FRONT AND REAR WINDSCREEN WIPER SWITCH

FRONT WINDSCREEN WIPER

- A - Front windscreen wiper off.
- B - Front windscreen wiper low speed setting.
- C - Front windscreen wiper high speed setting.
- D - Front windscreen wiper pulse driven.

REAR WINDSCREEN WIPER

- F - Rear windscreen wiper off.
- G - Rear windscreen wiper on.
- H - Rear windscreen washer, pulse driven (not used).

NOTE: These functions will only work when the ignition is switched on.

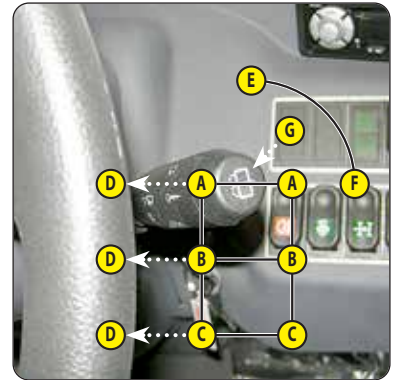

## 11 - STEERING SELECTION

### A - GREEN WHEEL ALIGNMENT INDICATOR LAMPS

**⚠ IMPORTANT ⚠**

*Before selecting one of the three steering possibilities, align the 4 wheels in relation to the lift truck axis.*

*Never change the steering mode whilst driving.*

These green indicator lamps come on to indicate the alignment of the wheels in relation to the lift truck. The A1 indicator lamp for the front wheels and the A2 indicator lamp for the rear wheels.

### B - STEERING SELECTION LEVER

- B1 - Front steering wheels (road mode).
- B2 - Front and rear steering wheels in opposite directions (short steering).
- B3 - Front and rear steering drive wheels in the same direction (crab steering).

CHECKING WHEEL ALIGNMENT

**⚠ IMPORTANT ⚠**

*Check the alignment of the front and rear wheels each time the lift truck is started.*

*Regularly check the alignment of the wheels when using the lift truck.*

*The wheels must be aligned and the lift truck must be in front steering wheels mode when used on public roads.*

*A green light comes on on the dashboard when the wheels are aligned.*

*Contact your dealer if you have any questions.*

- Select "short steering" (position B2).
- Turn the steering wheel and bring the rear wheels into alignment until the A2 indicator lamp comes on.
- Select "road driving" (position B1).
- Turn the steering wheel and bring the front wheels into alignment until the A1 indicator lamp comes on.

### C - SWITCH FOR ALIGNMENT OF THE WHEELS

This switch enables or disables the wheel alignment device. The indicator lamp indicates that it is in use.

- When driving on the road, disable the wheel alignment device.

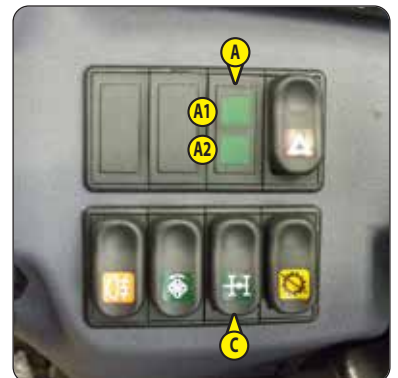

## 12 - FUSES AND RELAYS IN THE CAB

A sticker on the inside of the access panel provides a quick indication of the use of the fuse plate's components described below.

- Remove the access panel 1 to access the fuses and relays. Replace a used fuse with a new fuse of the same quality and capacity. Never reuse a repaired fuse.



### MINIFUSE

F1	7,5A	Rear camera (OPTION).
F2	15A	Rear working lights (OPTION).
F3	10A	Rear windscreen wiper.
		Roof windscreen wiper.
		Side windscreen wiper (OPTION).
F4	7,5A	Engine ECU wake-up.
		Diagnostic plug.
		Transmission and hydraulic oil temperature sensor. Fuel decongealant (OPTION).
F5	7,5A	Rotating beacon light. Green rotating beacon light (OPTION).
F6	5A	Wheel alignment. OPTION.
F7		OPTION.
F8	15A	JSM joystick.
		Transmission cut-off. Relay K2, K3, K4.
F9	5A	Control panel.
		Relay K17.
F10	10A	Horn.
		Stop switch.
F11	15A	Working lights on boom (OPTION).
F12	10A	Flashing unit.
F13	20A	Fan/heating.
F14	10A	12 V plug.
F15	20A	Hydraulic movement control unit.
F16	5A	Diagnostic plug.
		Heater relay control.
F17	10A	Self-cleaning fan (OPTION).
		Anti-theft system (OPTION).
F18	15A	Front working lights (OPTION).
F19	15A	Rear windscreen defrost (OPTION).
F20	10A	Pneumatic seat (OPTION).
F21	10A	Front windscreen wiper.
		Front windscreen washer.
F22	10A	Boom electrical predisposition (OPTION).
		Boom head electrovalve (OPTION).
F22	15A	Boom suspension (OPTION).
		Right sidelights.
F23	7,5A	Control panel illumination.
		Left sidelights.
F24	7,5A	Licence plate lighting (OPTION).
F25	7,5A	Right indicator lights.
F26	7,5A	Left indicator lights.
F27	15A	Dipped beam headlights.
		Rear fog lights.
F28	15A	Main beam headlights.
F29	15A	Hazard warning lights.
		Roof light.
		Anti-theft device predisposition.
		Rev counter.
F30	25A	Lighting, horn and indicator switch.
F31	5A	Starter relay.
F32	5A	Diagnostic plug.
		Hydraulic movement control unit power supply.
F33	2A	Control panel power supply.

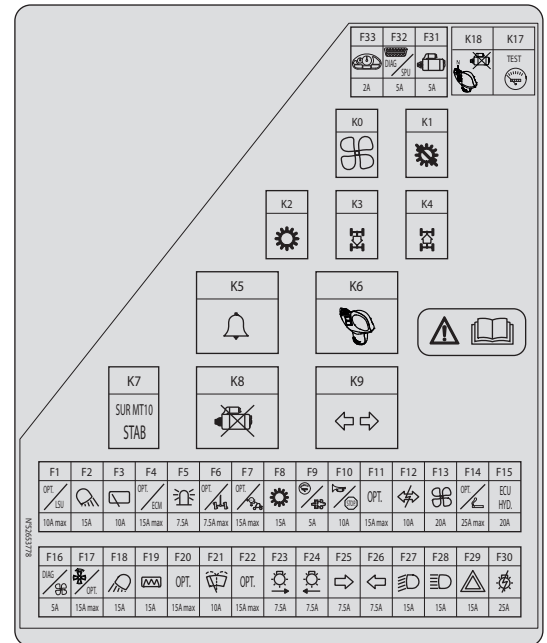

## RELAYS

K0	OPTION.
K1	Transmission cut-off relay.
K2	Transmission cut-off relay.
K3	Reverse gear relay.
K4	Forward gear relay.
K5	Buzzer.
K6	JSM activation relay.
K7	OPTION.
K8	Starter safety relay.
K9	Flashing unit.
K10	Boom suspension cut-off relay (OPTION).
K11	Boom suspension power supply relay (OPTION).
K17	Indicator lamps module relay.
K18	Neutral safety relay.

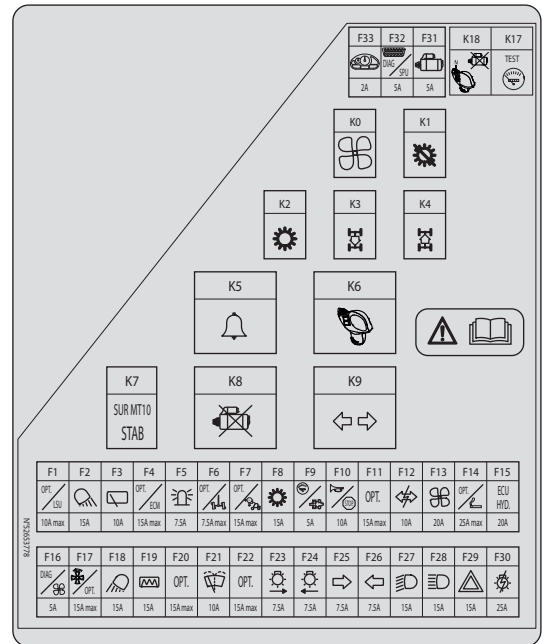

### 13 - FUSES AND RELAYS UNDER THE ENGINE COVER

- Open the engine bonnet, remove cover 1 to gain access to the fuses and relays. Replace a used fuse with a new fuse of the same quality and capacity. Never reuse a repaired fuse.

#### MINIFUSE

F41	5A	Engine diagnostic plug
F42		Free.
F43		Free.
F44	30A	Fuel decongealant (OPTION).
F45	15A	Relay power supply K23.
F46	30A	Air conditioning (OPTION).

#### MAXIFUSE

F47	30A	Engine control power unit.
F48	60A	Relay power supply K21.
F49	80A	Ignition switch.

#### RELAYS

K21	Engine preheat.
K23	Fuel pump.

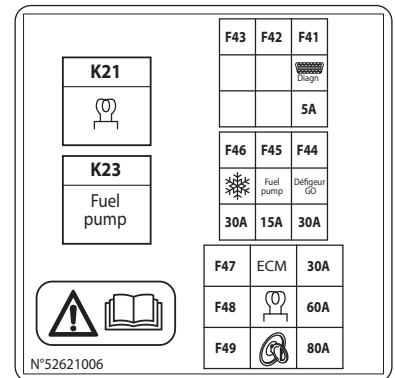
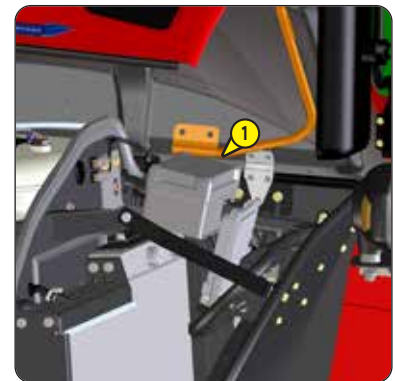

## 14 - DIAGNOSTIC PLUG



## 15 - ACCELERATOR PEDAL

### 16 - SERVICE BRAKE PEDAL AND TRANSMISSION CUT-OFF

The pedal acts on the front and rear wheels via a power assisted hydraulic braking system that slows the lift truck and brings it to a halt. Depending on the position of the transmission cut-off switch, it enables the transmission to be cut off during the free travel.

### 17 - GEAR LEVER AND TRANSMISSION CUT-OFF

In order to change gear, it is necessary to cut off the transmission by pressing button 1 on the lever.

#### USING THE GEARS ON THE GEAR BOX

On lift trucks such as these, that are equipped with torque converters, it is not necessary to systematically set off in first gear and work up through the gears.

#### **⚠ IMPORTANT ⚠**

*The gear box ratio selection should be made carefully depending on the work to be performed. A poor choice may result in the extremely rapid rise of the gear box oil temperature through excessive slipping of the converter, which could lead to serious gearbox damage (it is essential to stop and change the working conditions if the gear box oil temperature indicator lamp comes on).*

*This poor choice may also result in the forklift truck's performance deteriorating in forward gear. When the forward force increases, the forward speed in the r ratio (for example, in 3rd gear) may be lower than the forward speed that could be obtained with the r-1 gear (in 2nd instead of 3rd).*

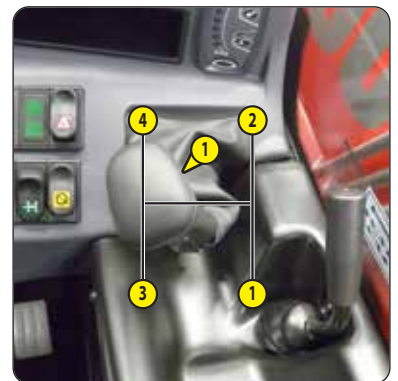

In general, we would advise you to use the following gears according to the nature of the work being carried out.

- ON THE ROAD: Set off in 3rd gear and change up to 4th if the conditions and state of the road permit it. In hilly areas, set off in 2nd gear and change up to 3rd if the conditions and state of the road permit it.
- WITH A TRAILER ON THE ROAD: Set off in 2nd gear and change up to 3rd if the conditions and state of the road permit it.
- HANDLING: Use 3rd gear. In confined spaces use 2nd gear.
- LOADING (picking-up with bucket, manure fork, etc.): Use 2nd gear.
- EARTH MOVING: Use 1st gear.

### 18 - PARKING BRAKE LEVER

To prevent accidental loosening or release, the lever is fitted with safety locking.

- To apply the parking brake, pull the lever backwards (position A).
- To loosen the parking brake, release and push the lever forwards (position B).

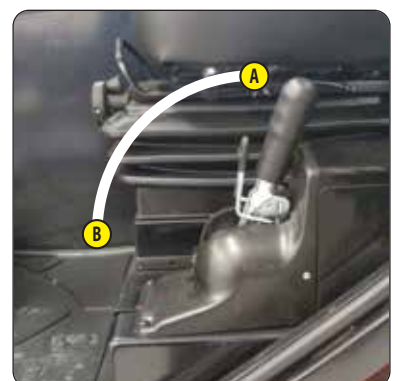

## 19 - FORWARD/NEUTRAL/REVERSE GEAR SELECTION

When changing the direction of travel, the lift truck should be travelling at slow speed and not accelerating.

- FORWARD: Push the switch forward (position A).
- REVERSE: Push the switch backward (position B). Reversing lights and an acoustic reversing alarm indicate that the lift truck is travelling in reverse.
- NEUTRAL: The switch must be in the neutral position (position C) to start the lift truck.

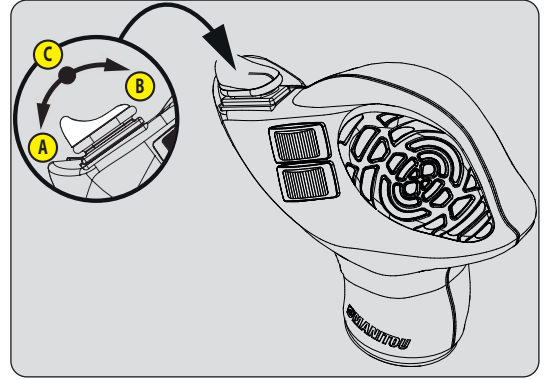

### SAFETY FOR MOVING THE LIFT TRUCK

The operator must observe the following sequence to move the truck forwards or backwards:

- 1 - sit down correctly in the driver's seat,
- 2 - release the hand brake,
- 3 - engage forward or reverse.

NOTE: The alternating display of F/N or R/N on the screen and a rapid, discontinuous audible signal indicates that the selector needs to be set to neutral.

To stop the forklift truck without switching off the ignition, the following sequence must be followed:

- 1 - Set the forward/reverse selector to neutral,
- 2 - Apply the parking brake,
- 3 - Get out of the lift truck.

NOTE: A discontinuous audible signal and a message on the screen will inform the driver if he has left the driver's cab without applying the parking brake.

## 20 - HYDRAULIC CONTROLS

### ⚠ IMPORTANT ⚠

*Do not attempt to alter the hydraulic system pressure by interfering with the pressure regulating valve. In the event of suspected malfunction, contact your dealer. ANY ALTERATION MAY RENDER THE WARRANTY NULL AND VOID AND INCURS LIABILITY IN THE EVENT OF AN ACCIDENT.  
Use the hydraulic controls gently without jerking, to avoid incidents caused by shaking the lift truck.*

NOTE: If necessary, operate the steering to reset the hydraulic control steering accumulator.

### HYDRAULIC CONTROLS ACTIVATION

This safety device prevents accidental operation of the hydraulic lifting, tilting, telescoping and attachment controls.

USING THE BUTTON	USING THE CAPACITIVE SENSOR
<p>The diagram shows a hand on the control lever. An arrow points to a button on the lever. A circular inset shows a close-up of the button being pressed. Below, another view shows the lever with arrows indicating hydraulic movement.</p>	<p>The diagram shows a hand on the control lever. An arrow points to a capacitive sensor on the lever. A circular inset shows a close-up of the hand touching the sensor. Below, another view shows the lever with arrows indicating hydraulic movement.</p>
<p>- Place your hand on the lever, activate the hydraulic controls by pressing the button and perform the hydraulic movement.</p>	<p>- Place your hand on the lever, activate the hydraulic controls by contact on the capacitive sensor and perform the hydraulic movement.</p>
<p>- Hydraulic controls activation is maintained on a timer while the lift truck is being used. - If necessary, reactivate the hydraulic controls.</p>	

**A1 - LIFTING**

**A2 - LOWERING**

**B1 - EXCAVATION**

**B2 - DUMP**

**C1 - TELESCOPE EXTENSION**

**C2 - TELESCOPE RETRACTION**

**D1 - ATTACHMENT**

**D2 - ATTACHMENT**

**E - BOOM ELECTRICAL PREDISPOSITION (OPTION)**

**BOOM HEAD ELECTROVALVE (OPTION)**

(↖ DESCRIPTION AND USE OF THE OPTIONS).

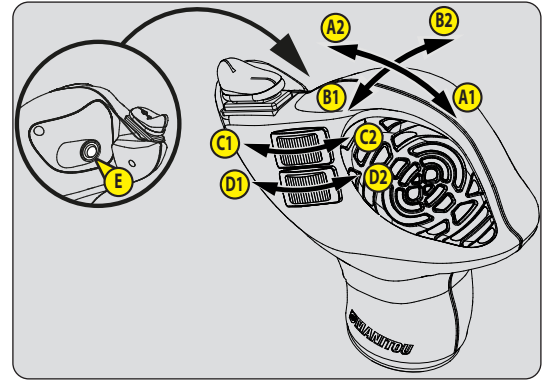

## **21 - FUNCTION FILES**

These files contain the description of the hydraulic controls and the load charts for the attachments used on the lift truck.



## **22 - LEVEL INDICATOR**

Enables the operator to check that the lift truck is in the horizontal position.



## 23 - HEATER CONTROL

### A - FAN CONTROL

This 4-speed control allows the air to be ventilated through the air vents.

### B - TEMPERATURE CONTROL

Adjusts the temperature inside the cab.

- B1 - The fan pumps in the air at ambient temperature.
- B2 - The fan pumps in warm air.

The intermediate positions allow the temperature to be adjusted.



## 24 - AIR CONDITIONING CONTROLS (AIR CONDITIONING OPTION)

### ⚠ IMPORTANT ⚠

*The air conditioning only works if the lift truck has been started.*

*When using your air conditioning, it is essential to work with the cab closed.*

*In winter: So as to ensure that the air conditioning unit is correctly operated and completely efficient, start up the compressor once a week, even for a short period of time, in order to lubricate the internal seals.*

*In cold weather: Warm the engine before switching on the compressor, in order to allow the coolant that has collected in the liquid state at the lowest point of the compressor's circuit to turn into gas under the effect of the heat given off by the engine, as the compressor is liable to be damaged by coolant in the liquid state.*

*If your air conditioning does not seem to be working correctly, have it examined by your dealer.*

*Never try to repair any faults yourself.*

### A - FAN CONTROL

This 3-speed control allows the air to be ventilated through the air vents.

### B - TEMPERATURE CONTROL

Adjusts the temperature inside the cab.

- B1 - The fan pumps in cold air.
- B2 - The fan pumps in warm air.

The intermediate positions allow the temperature to be adjusted.



### C - AIR CONDITIONING CONTROL

This control with a pilot light allows the air conditioning unit to be switched on.

#### HEATING MODE

- The controls must be adjusted in the following way:
  - C - Control with pilot light off.
  - B - At the desired temperature.
  - A - At the desired speed: 1, 2 or 3.

#### AIR CONDITIONING MODE

- The controls must be adjusted in the following way:
  - C - Control with pilot light on.
  - B - At the desired temperature.
  - A - At the desired speed: 1, 2 or 3.

#### DEMISTING MODE

- The controls must be adjusted in the following way:
  - C - Control with pilot light on.
  - B - At the desired temperature.
  - A - At speed 2 or 3.
- For optimum effectiveness, close the heating ventilators.

## 25 - WINDSCREEN DEMISTER VENTS

For optimum effectiveness, close the heating ventilators.

## 26 - HEATING VENTS

These swivelling heating vents, which can be shut off, allow you to direct and adjust the flow inside the cab.

### **27 - STEERING WHEEL ADJUSTMENT LEVER (OPTION)**

This handle enables the angle and height of the steering wheel to be adjusted.

- Pull the knob backwards.
- Adjust the steering wheel to the desired position.
- Push the knob back to lock the steering wheel in position.



### **28 - DOOR OPENING HANDLE**

Two keys are provided with the lift truck to enable the cab to be locked.

- Pull on the handle to open the door.



### **29 - LOCKING HANDLE FOR UPPER HALF-DOOR**

- Pull on the handle to release the upper half-door.
- Open the half-door fully and make sure it is locked in the open position.



### **30 - UNLOCKING BUTTON FOR UPPER HALF-DOOR**

### **31 - HANDLE FOR REAR WINDOW OPENING**

#### **EMERGENCY EXIT**

Use the rear window as an emergency exit, in the event that it is impossible to leave the cab by the door or by opening the windscreen.



### **32 - STORAGE COMPARTMENT**

There is an OPTIONAL cover for the storage compartment.

### **33 - STORAGE NET**

Ensure that the operator's manual is in its place in the storage net.



**34 - SUN VISOR (OPTION)**

---

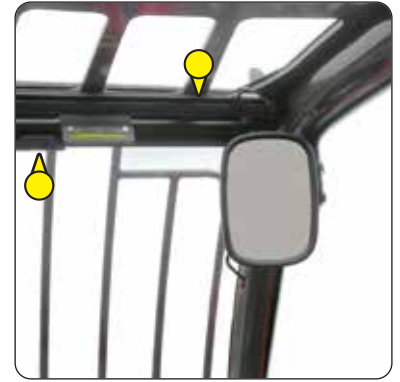

**35 - ROOF LIGHT**

---

**36 - HOOK**

---



**37 - INSIDE REAR-VIEW MIRROR (OPTION)**

---



**38 - ARMREST**

---

Lift the armrest to access the storage.

**39 - 12V SOCKET**

---

For 12 V appliance and max. amperage 15A.



## 40 - BATTERY CUT-OFF

For quickly disconnecting the battery when working on the electric circuit or when soldering, for example.

### ⚠ IMPORTANT ⚠

*Operate the battery cut-off no less than 30 seconds after turning off the ignition with the ignition key.*



## 41 - FRONT HEADLIGHTS

- A - Front left-hand indicator light.
- B - Front left-hand dipped headlight.
- C - Front left-hand headlight.
- D - Front left-hand sidelight.
- E - Front right-hand indicator light.
- F - Front right-hand dipped headlight.
- G - Front right-hand headlight.
- H - Right front sidelight.



## 42 - REAR LIGHTS

- A - Rear left-hand indicator light.
- B - Rear left-hand stop light.
- C - Rear left-hand headlight.
- D - Rear left-hand reversing light.
- E - Rear left-hand fog light.
- F - Rear right-hand fog light.
- G - Rear right-hand reversing light.
- H - Rear right hand headlight.
- I - Rear right-hand stop light.
- J - Rear right-hand indicator light.

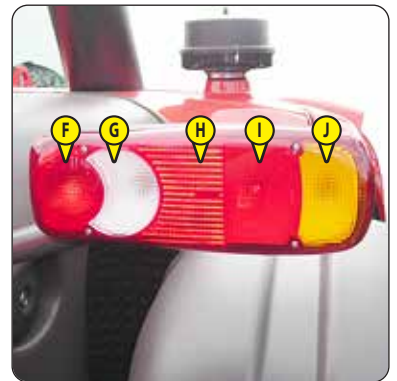
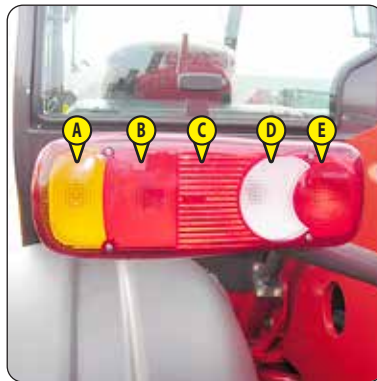

## 43 - ROTATING BEACON LIGHT

The magnetic rotating beacon light must be clearly visible on the roof of the cab and plugged into socket 1.



## 44 - BOOM SAFETY WEDGE

### **⚠ IMPORTANT ⚠**

*Only use the wedge supplied with the lift truck.*

The lift truck is equipped with a boom safety wedge which must be installed on the rod of the lifting cylinder when working beneath the boom (⇐ 1 - OPERATING AND SAFETY INSTRUCTIONS).



## 45 - FUEL TANK

As far as possible, keep the fuel tank well filled in order to minimise condensation due to the atmospheric conditions.

### **⚠ IMPORTANT ⚠**

*Never smoke or approach with a flame during filling operations or when the tank is open.*

*Never refill while engine is running.*

- If necessary, add diesel (⇐ 3 - MAINTENANCE: LUBRICANTS AND FUEL).
- Remove the cap 1.
- Fill the fuel tank with clean diesel filtered through the filler port.
- Refit the cap.
- Visually check that there is no leakage in the tank and pipes.

NOTE: A locking tank cap is available as an OPTION.





## TOWING DEVICE

### ⚠ IMPORTANT ⚠

*Do not tow a trailer or an attachment that is not in perfect working condition.  
Using a trailer in poor condition may affect the lift truck's steering and braking, and hence the safety of the assembly.  
If a third party helps in coupling or uncoupling the trailer, this person must be permanently visible to the driver and wait until the lift truck has stopped, the handbrake is on and the I.C. engine is switched off before performing the operation.*

Located at the rear of the lift truck, this device is used to couple a trailer. Capacity is limited for each lift truck by the authorised gross vehicle weight (AGVW), tractive effort and maximum vertical force on the coupling point. This information is given on the manufacturer's plate fixed to each lift truck (⇐ IDENTIFICATION OF THE LIFT TRUCK).

- To use a trailer, see current regulations in your country (maximum running speed, braking, maximum weight of trailer, etc.).
- Verify the trailer's condition before using it (tyre condition and pressures, electrical connection, hydraulic hose, brake system...).

### 1 - CLEVIS HITCH

#### ⚠ IMPORTANT ⚠

*Be careful not to get your fingers caught or crushed during this operation.  
Do not forget to put the cotter pin back in place.  
When uncoupling, make sure that the trailer is supported independently.*

#### COUPLING AND UNCOUPLING THE TRAILER

- To couple the trailer, position the lift truck as close as possible to the trailer ring.
- Apply the handbrake on and switch off the engine.
- Remove the pin 1, lift the towing pin 2 and place or remove the trailer ring.

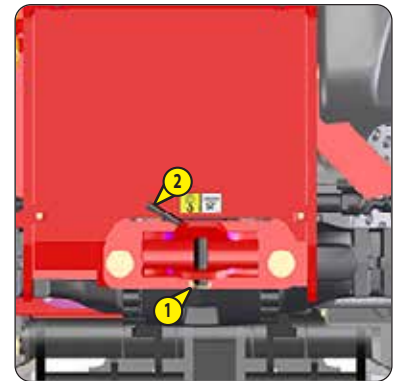

### 2 - REAR ELECTRIC SOCKET (OPTION)

- Connect the male plug to the female socket 1 on the lift truck and make sure the lights of the trailer or the light bar are working properly.
  - 1 - Left rear turn signal.
  - 2 - Rear fog light.
  - 3 - Ground.
  - 4 - Right rear turn signal.
  - 5 - Right rear light.
  - 6 - Rear left and right brake lights.
  - 7 - Left rear light.

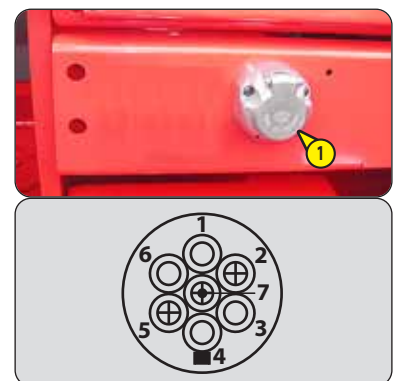

### 3 - REAR-VIEW MIRROR

The rear-view mirror allows the lift truck to approach the trailer ring more precisely.

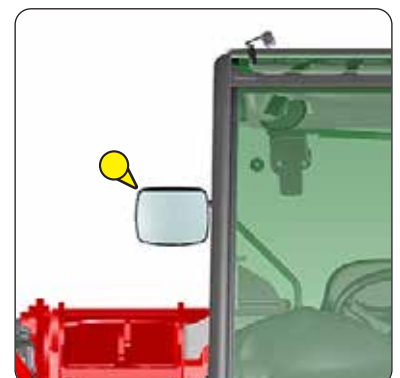



## DESCRIPTION AND USE OF THE OPTIONS

1 - WINDSCREEN GRILL .....	2-49
2 - REAR WINDOW STAY .....	2-49
3 - PROTECTIVE GRILLE FOR HEADLIGHTS AND REAR LIGHTS. ....	2-49
4 - TOOL BOX .....	2-49
5 - WATERPROOF DOCUMENT HOLDER .....	2-49
6 - BOOM HEAD SEALING .....	2-50
7 - ANGULAR SECTOR ON BOOM .....	2-50
8 - "A-B-C-D-E" MARKING ON BOOM .....	2-50
9 - LICENSE PLATE LIGHT .....	2-50
10 - ANTI-THEFT SYSTEM MODCOD .....	2-50
11 - SELF-CLEANING FAN CLEANFIX .....	2-51
12 - FUEL DECONGEALANT .....	2-51
13 - PREHEAT ROD .....	2-51
14 - GREEN ROTATING BEACON LIGHT .....	2-51
15 - REAR CAMERA .....	2-52
16 - ENGINE SPEED REGULATOR .....	2-52
17 - BOOM ELECTRICAL PREDISPOSITION .....	2-52
18 - ATTACHMENT CIRCUIT WITH QUICK-RELEASE COUPLERS .....	2-52
19 - EXTERIOR DRAIN-BACK .....	2-53
20 - ATTACHMENT HYDRAULIC CONTROL FORCED OPERATION .....	2-53
21 - BOOM SUSPENSION .....	2-53
22 - ATTACHMENT EASY HYDRAULIC CONNECTION .....	2-54
23 - ATTACHMENT HYDRAULIC LOCKING .....	2-54
24 - BOOM HEAD ELECTROVALVE .....	2-55
25 - BOOM HEAD ELECTROVALVE + HYDRAULIC ATTACHMENT LOCKING .....	2-55
26 - LIFTING RING ON SINGLE CARRIAGE .....	2-56

## **1 - WINDSCREEN GRILL**

### **DESCRIPTION**

The windscreen grill provides additional protection for the operator from any external elements spattered on the windscreen.

This grill must be removable from inside the cab to enable an emergency exit.

### **EMERGENCY EXIT**

- After breaking the windscreen with the emergency hammer, push (with force) on the windscreen grill at A to remove it.



## **2 - REAR WINDOW STAY**

- Holds the rear window half-open.



## **3 - PROTECTIVE GRILLE FOR HEADLIGHTS AND REAR LIGHTS**



## **4 - TOOL BOX**



## **5 - WATERPROOF DOCUMENT HOLDER**



## 6 - BOOM HEAD SEALING

---



## 7 - ANGULAR SECTOR ON BOOM

---

The angular sector displays the boom angle, and thus improves the reading of the load charts.



## 8 - "A-B-C-D-E" MARKING ON BOOM

---

The marking indicates the outreach of the boom and therefore improves reading of the load charts.

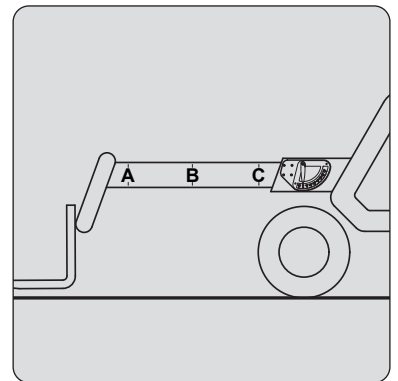

## 9 - LICENSE PLATE LIGHT

---



## 10 - ANTI-THEFT SYSTEM MODCOD

---

### OPERATION

- Switch on the lift truck: the red indicator 1 will flash.
- Enter your user code followed by "V" to validate: the green indicator 2 will come on.
- Start the lift truck within the next 60 seconds; otherwise the anti-theft system will be reactivated and the red indicator 1 will flash.

NOTE: If you make a mistake when entering the code, press key "A" to cancel and re-enter the code in full. If you wait more than 5 seconds between key presses or do not complete entering the code, the anti-theft system will be reactivated and the red indicator will flash.



## 11 - SELF-CLEANING FAN CLEANFIX

Cleans the radiator core and the grille of the engine cover by reversing the air flow.

### ⚠ IMPORTANT ⚠

*When in use, beware of the risk of projection into the eyes.*

#### OPERATION

- Set switch 1 to position A (indicator light on), the fan operates in self-cleaning mode for a few seconds once every 3 minutes.
- Set switch 1 to position B (indicator light on), the fan operates normally.



## 12 - FUEL DECONGELANT

The paraffin particles found naturally in diesel crystallise at low temperatures. The fuel decongelant helps to limit accumulation in the filter.



## 13 - PREHEAT ROD

Enables the engine to be kept warm during prolonged periods of stoppage and thus improves engine starting.

#### ENVIRONMENTAL CONDITIONS FOR USE:

- Maximum ambient temperature for using preheating: +77°F (+ 25 °C)

#### CONDITIONS FOR CONNECTION AND USE OF PREHEATING:

- The preheating system should not be used for an external ambient temperature higher than +77°F (+ 25 °C).
- 
- It is essential that the power supply to the preheating system:
  - Is effected with a cable that conforms to the installation standards in force and contains a protective earth conductor.
  - Contains an appropriate sectioning system.
  - Incorporates an appropriate safety system against short circuits (fuses or circuit breaker) and a differential circuit breaker with 30 mA sensitivity.
- Only connect to and disconnect from the power supply while the unit is switched off and the engine is stopped.

### ⚠ IMPORTANT ⚠

*Make sure that the electrical extension is still correctly stored in its place in the document holder net.*



## 14 - GREEN ROTATING BEACON LIGHT

The magnetic green rotating beacon light must be clearly visible on the roof of the cab and plugged in to socket 1.

- It indicates that the operator has fastened the seat belt.
- Do not use the green rotating beacon light on public roads.

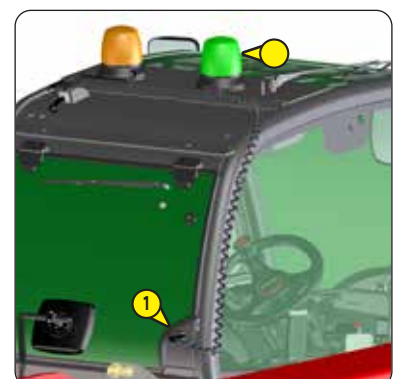

## 15 - REAR CAMERA



## 16 - ENGINE SPEED REGULATOR

**⚠ IMPORTANT ⚠**

*The engine speed regulator cannot under any circumstances be used while driving on the road.*

### OPERATION

- Turn button 1 to increase or reduce the engine speed, and thus control the hydraulic flow within the attachment circuit.
- View the rev. counter to adjust the engine speed.
- Return the engine to idle before switching off the lift truck's ignition.



## 17 - BOOM ELECTRICAL PREDISPOSITION

Enables an electrical function to be used at the boom head.

### ATTACHMENT LINE CONTROL

- Put switch 1 to position A (indicator lamp off).
- Push switch 2 forward or backward.

### BOOM ELECTRIC FUNCTION CONTROL

- Set switch 1 to position B (indicator lamp on).
- Hold down button 3 and operate button 2 forwards or backwards.

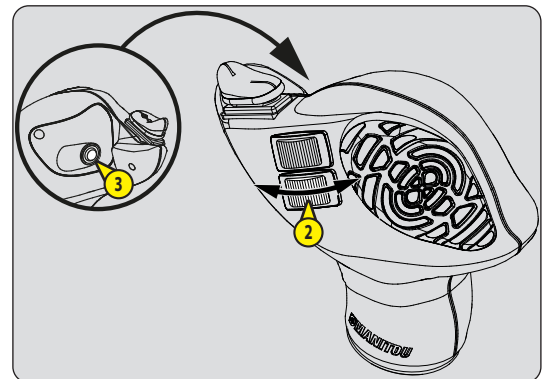

## 18 - ATTACHMENT CIRCUIT WITH QUICK-RELEASE COUPLERS



## 19 - EXTERIOR DRAIN-BACK

Enables connection of a hydraulic attachment for which drain-back is required.



## 20 - ATTACHMENT HYDRAULIC CONTROL FORCED OPERATION

### ⚠ IMPORTANT ⚠

*This OPTION must only be used with an attachment requiring continuous hydraulic movement, such as a brush, feeder bucket, mixer, spray etc. It is strictly forbidden for use in handling operations and all other applications (winch, crane jib, crane jib with winch, hook, etc.).*

*Never leave the driver's cab without resetting the potentiometer C to 0%.  
Before starting the lift truck, make sure that this potentiometer is at 0%.*

### CONTINUOUS HYDRAULIC MOVEMENT OF THE ATTACHMENT

- Check that potentiometer C is set to 0 %.
- Switch button A to the front or the back (depending on the type of attachment), press button B and release button A. The red indicator 1 flashes to indicate that it is in operation.
- Set the required flow rate using potentiometer C.
- To stop continuous hydraulic movement of the attachment, move switch A forwards or backwards or press button B. Indicator 1 goes out.
- Set potentiometer C to 0 %.

NOTE: If the operator leaves the driver's cab, the continuous hydraulic movement will automatically stop and must be restarted.

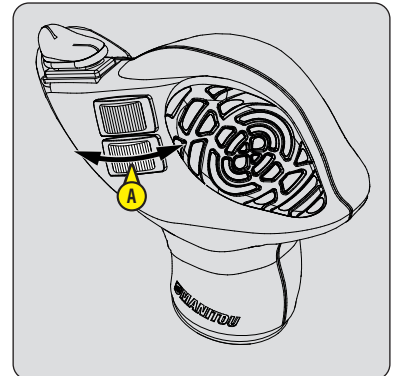

## 21 - BOOM SUSPENSION

The boom suspension dampens shaking of the lift truck on rough ground (e.g. handling straw in a field).

### ⚠ IMPORTANT ⚠

*The boom suspension remains active up to carriage hinge pin lift height of 118.11 in (3.00 m) relative to the ground, with the boom retracted.*

*When you exceed this height or when you perform another hydraulic movement (tilt, telescoping, attachment), the boom suspension is momentarily deactivated and the lamp on switch 1 goes out.*

### OPERATION

- Set the forks or attachment down on the ground and raise the front wheels by a few centimetres only.
- Press switch 1 in position A, the indicator lamp comes on indicating that boom suspension is activated.
- Press switch 1 in position B, the indicator lamp goes out indicating that the boom suspension is deactivated.
- When the engine is off, boom suspension is automatically deactivated.



## 22 - ATTACHMENT EASY HYDRAULIC CONNECTION

For easy connection and disconnection of hydraulic attachments.

### OPERATION

- Switch on lift truck ignition.
- Press for two seconds on pushbutton 1 to release the attachment circuit hydraulic pressure.
- Connect or disconnect the quick couplers of the hydraulic attachment (⇐ 4 - ADAPTABLE ATTACHMENTS AS AN OPTION ON THE RANGE: PICKING UP THE ATTACHMENTS).



## 23 - ATTACHMENT HYDRAULIC LOCKING

Enables the attachment to be locked onto the carriage and a hydraulic attachment to be used by the same hydraulic circuit.

### ⚠ IMPORTANT ⚠

*After locking the attachment, return switch 2 to position A (indicator lamp off) to prevent accidental unlocking of the attachment.*

### ATTACHMENT LOCKING CONTROL

- Put tap 1 in position A and press switch 2 at position B (indicator lamp on).
- Push switch 3 forward to lock the attachment and backward to release it.

### HYDRAULIC ATTACHMENT CONTROL

- Set valve 1 to position B and press switch 2 in position B (indicator lamp on).
- Push switch 3 forward or backward.

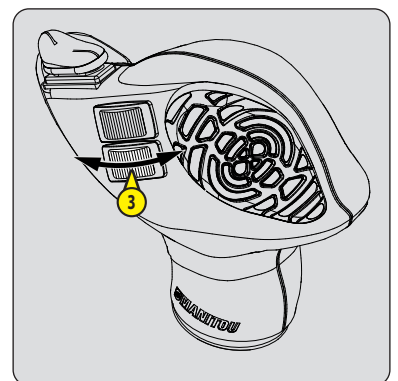
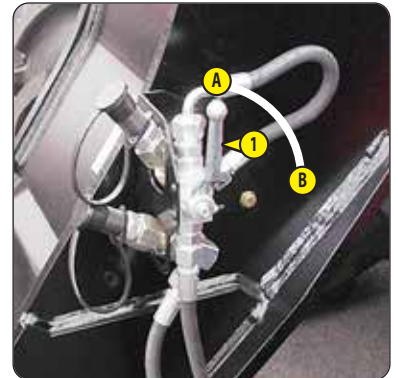

## 24 - BOOM HEAD ELECTROVALVE

Enables use of two hydraulic functions on the attachment circuit.

NOTE: For ease of connection of the quick-release couplers, decompress the hydraulic circuit by pressing button 1 on the electrovalve.

### ATTACHMENT LINE L1 CONTROL

- Put switch 2 to position A (indicator lamp off).
- Push switch 3 forward or backward.

### ATTACHMENT LINE L2 CONTROL

- Set switch 2 to position B (indicator lamp on).
- Hold down button 4 and operate button 3 forwards or backwards.

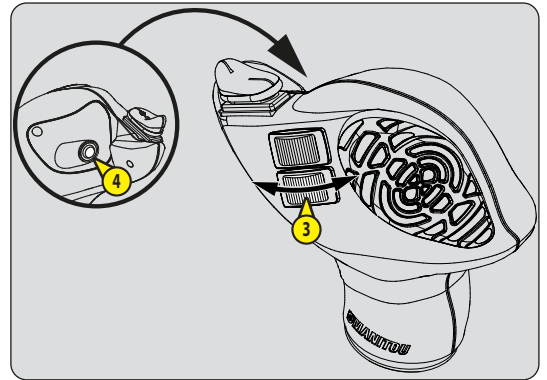
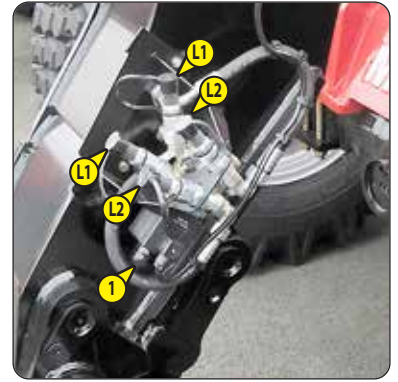

## 25 - BOOM HEAD ELECTROVALVE + HYDRAULIC ATTACHMENT LOCKING

The addition of these two options on the attachment line allows two hydraulic functions to be used and locks the attachment onto the carriage.

### ⚠ IMPORTANT ⚠

To facilitate connection of the quick couplers, decompress the hydraulic circuit by pressing button 1 on the electrovalve. Once the attachment is locked, return valve 4 to position B to prevent accidental release of the attachment.

### ATTACHMENT LINE L1 CONTROL

- Put switch 2 to position A (indicator lamp off).
- Push switch 3 forward or backward.

### ATTACHMENT LINE L2 CONTROL + HYDRAULIC ATTACHMENT LOCKING

#### LOCKING AN ATTACHMENT

- Set valve 4 to position A.
- Set switch 2 to position B (indicator lamp on).
- Hold down button 5 and push button 3 forward to lock the attachment and backward to release it.

#### HYDRAULIC ATTACHMENT

- Set switch 2 to position B (indicator lamp on).
- Hold down button 5 and operate button 3 forwards or backwards.

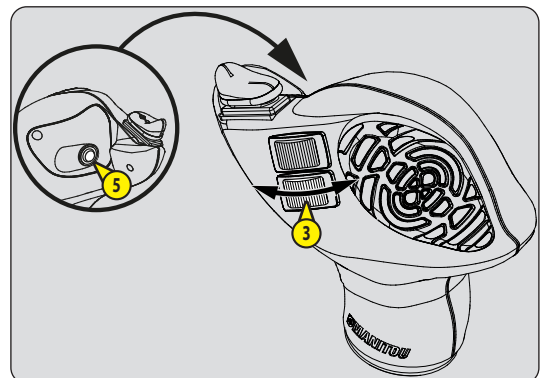
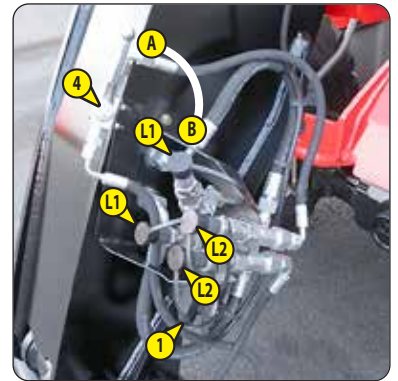

## 26 - LIFTING RING ON SINGLE CARRIAGE

### CONDITIONS OF USE

#### **⚠ IMPORTANT ⚠**

Follow the instructions given in the instruction manual (← 1 - OPERATING AND SAFETY INSTRUCTIONS: INSTRUCTIONS FOR HANDLING LOADS).

The load charts are defined for use without forks and without attachments (← SAFETY PLATES AND STICKERS).

- The lifting ring must be used WITHOUT FORKS AND ATTACHMENTS, but the angle of inclination of the carriage must be the same as when the forks are used in the horizontal position.
- Check the maximum permitted angle, which is 45°.
- Do not change the angle of the carriage while using the lifting ring.
- The lifting hook, the chains and slings shall have a minimum capacity of 6614 lb (3000 kg) with a safety coefficient of 4 in relation to breakage.

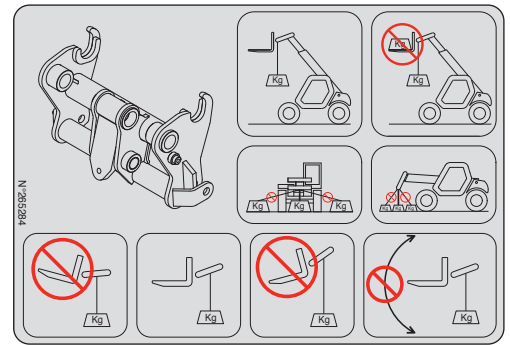

# ***3 - MAINTENANCE***

### 3 - MAINTENANCE

<b>ORIGINAL MANITOU SPARE PARTS AND EQUIPMENT</b>	<b>3-3</b>
<b>FORKLIFT TRUCK MAINTENANCE</b>	<b>3-4</b>
<b>DAILY AND WEEKLY MAINTENANCE</b>	<b>3-4</b>
<b>MANDATORY FIRST 500 HOURS OR 6 MONTHS SERVICE</b>	<b>3-5</b>
<b>PERIODIC SERVICE</b>	<b>3-6</b>
<b>OCCASIONAL MAINTENANCE AND OPERATION</b>	<b>3-8</b>
<b>FILTERING ELEMENTS AND BELTS</b>	<b>3-9</b>
<b>LUBRICANTS AND FUEL</b>	<b>3-10</b>
<b>➞ 10H - DAILY SERVICE OR EVERY 10 HOURS OF SERVICE</b>	<b>3-12</b>
<b>➞ 50H - WEEKLY SERVICE OR EVERY 50 HOURS OF SERVICE</b>	<b>3-14</b>
<b>➞ ① 250H - PERIODIC SERVICE - EVERY 250 HOURS OF SERVICE</b>	<b>3-20</b>
<b>➞ ② 500H - PERIODIC SERVICE - EVERY 500 HOURS OF SERVICE OR 1 YEAR</b>	<b>3-22</b>
<b>➞ ③ 1000H - PERIODIC SERVICE - EVERY 1,000 HOURS OF SERVICE OR 2 YEARS</b>	<b>3-26</b>
<b>➞ ④ 2000H - PERIODIC SERVICE - EVERY 2,000 HOURS OF SERVICE OR 4 YEARS</b>	<b>3-32</b>
<b>➞ OCCASIONAL MAINTENANCE</b>	<b>3-36</b>
<b>➞ OCCASIONAL OPERATION</b>	<b>3-38</b>

## ORIGINAL MANITOU SPARE PARTS AND EQUIPMENT

OUR LIFT TRUCKS MUST BE SERVICED USING ORIGINAL MANITOU PARTS.

### **BY ALLOWING THE USE OF NON ORIGINAL MANITOU PARTS, YOU RISK:**

#### **⚠ IMPORTANT ⚠**

**THE USE OF COUNTERFEIT PARTS OR COMPONENTS NOT APPROVED BY THE MANUFACTURER, MEANS YOU LOSE THE BENEFIT OF THE CONTRACTUAL GUARANTEE.**

- Legally - to be held responsible in the event of an accident.
- Technically - to cause operating malfunctions or shorten the life of the lift truck.

### **BY USING ORIGINAL MANITOU PARTS FOR MAINTENANCE OPERATIONS, YOU BENEFIT FROM OUR KNOW-HOW**

Through its network, MANITOU provides the user with,

- Know-how and competence.
- The guarantee of high-quality work.
- Original replacement parts.
- Help with preventive maintenance.
- Efficient help with diagnosis.
- Improvements due to experience feedback.
- Operator training.
- Only the MANITOU network has detailed knowledge of the design of the lift truck and therefore the best technical ability to provide maintenance.

#### **⚠ IMPORTANT ⚠**

**ORIGINAL REPLACEMENT PARTS ARE DISTRIBUTED EXCLUSIVELY BY MANITOU AND ITS DEALER NETWORK.**

*The dealer network list is available on the MANITOU web site: [www.manitou.com](http://www.manitou.com)*

## FORKLIFT TRUCK MAINTENANCE

### DAILY AND WEEKLY MAINTENANCE

#### **⚠ IMPORTANT ⚠**

**THE OPERATOR IS AUTHORISED TO CARRY OUT THIS MAINTENANCE.**

These maintenance operations enable the operator to maintain the lift truck in a clean and safe condition.

### MANDATORY FIRST 500 HOURS OR 6 MONTHS SERVICE

#### **⚠ IMPORTANT ⚠**

**THIS SERVICE MUST BE CARRIED OUT AFTER THE FIRST 500 HOURS OF SERVICE OR WITHIN THE 6 MONTHS FOLLOWING PUTTING THE MACHINE INTO SERVICE (WHICHEVER OCCURS FIRST).**

### PERIODIC SERVICE

#### **⚠ IMPORTANT ⚠**

**THE PERIODIC MAINTENANCE MUST BE CARRIED OUT BY AN APPROVED PROFESSIONAL FROM THE MANITOU NETWORK.**

### MAINTENANCE SCHEDULE

This schedule enables the operator to keep up with the periodic service of the lift truck by notifying the total number of hours of operation and the date of the service performed by the professional approved by the MANITOU network.

### OCCASIONAL MAINTENANCE AND OPERATION

These maintenance tasks and operations are to be performed as required for the safety and upkeep of the lift truck.

## DAILY AND WEEKLY MAINTENANCE

### 🔄 10H - DAILY SERVICE OR EVERY 10 HOURS OF SERVICE

- CHECK	Lift truck environment .....	3-12
- CHECK	Engine oil level .....	3-12
- CHECK	Cooling liquid level .....	3-12
- CHECK	Fuel pre-filter .....	3-13
- CLEAN	Cyclonic pre-filter .....	3-13

### 🔄 50H - WEEKLY SERVICE OR EVERY 50 HOURS OF SERVICE

- CHECK	Gear box oil level .....	3-14
- CHECK	Tyre pressures .....	3-14
- CHECK	Wheel nut tightening .....	3-14
- CHECK	Front axle differential seal .....	3-14
- CHECK	Rear axle differential seal .....	3-14
- CHECK	Front wheel reducer seals .....	3-14
- CHECK	Rear wheel reducer seals .....	3-14
- CHECK	Brake fluid level .....	3-15
- CHECK	Boom pad slide pathways .....	3-15
- CHECK	Hydraulic oil level .....	3-16
- CHECK	Windscreen washer liquid level .....	3-16
- CLEAN	Radiator cores .....	3-16
- CLEAN	Dry air filter cartridge .....	3-17
- CLEAN	Condenser harness (Air conditioning OPTION) .....	3-17
- LUBRICATE	General lubrication .....	3-18

## MANDATORY FIRST 500 HOURS OR 6 MONTHS SERVICE

### FIRST 500 HOURS BEFORE THE FIRST 6 MONTHS

- If the lift truck has reached the first 500 hours of service before the first 6 months have expired, perform both the mandatory service and periodic 500 H service (◀ ▶ ① 500H - PERIODIC SERVICE - EVERY 500 HOURS OF SERVICE OR 1 YEAR).

### FIRST 6 MONTHS BEFORE THE FIRST 500 HOURS

- If the lift truck has not completed 500 hours of service in the first 6 months, just carry out the mandatory service.

## MANDATORY SERVICE

- CHECK	Gear box oil level.....	3-14
- CHECK	Tyre pressures .....	3-14
- CHECK	Wheel nut tightening .....	3-14
- CHECK	Front axle differential seal .....	3-14
- CHECK	Rear axle differential seal .....	3-14
- CHECK	Front wheel reducer seals .....	3-14
- CHECK	Rear wheel reducer seals .....	3-14
- CHECK	Brake fluid level.....	3-15
- CHECK	Boom pad slide pathways .....	3-15
- CHECK	Hydraulic oil level.....	3-16
- CHECK	Windscreen washer liquid level.....	3-16
- CLEAN	Radiator cores .....	3-16
- CLEAN	Dry air filter cartridge .....	3-17
- CLEAN	Condenser harness (Air conditioning OPTION) .....	3-17
- LUBRICATE	General lubrication .....	3-18
- CHECK	Angle gear box oil level .....	3-20
- CHECK	Parking brake.....	3-20
- CLEAN	Heating block check valve.....	3-20
- CHECK	Countdown before "stationary lift truck" exhaust regeneration.....	3-22
- CHECK	Alternator belt tension .....	3-22
- CHECK	Hydraulic oil .....	3-22
- LUBRICATE	Parking brake lever mechanism .....	3-23
- CHECK	Fork wear * .....	3-25
- CHECK	Seat belt.....	3-26
- CLEAN	Fuel tank .....	3-26
- CHECK	Engine silent blocks * .....	3-31
- CHECK	Valve lash * .....	3-31
- CHECK	Gearbox silent blocks * .....	3-31
- CHECK	Gear box controls * .....	3-31
- CHECK	Brake system pressure * .....	3-31
- CHECK	Boom pad wear * .....	3-31
- CHECK	Condition of wiring harnesses and cables * .....	3-31
- CHECK	Lights and signals * .....	3-31
- CHECK	Warning indicators * .....	3-31
- CHECK	Condition of the rear-view mirrors * .....	3-31
- CHECK	Cabin structure * .....	3-31
- CHECK	Frame structure * .....	3-31
- CHECK	Attachment carriage * .....	3-31
- CHECK	Condition of attachments * .....	3-31

*\* Consult your dealer.*

## PERIODIC SERVICE

### MAINTENANCE SCHEDULE

		↻ OR ↻				
WHEN DUE ↻	250 H	FIRST 6 MONTHS	FIRST 500 HOURS	500 H or 1 YEAR	750 H	1000 H or 2 YEARS
PERIODIC SERVICE ↻	①	MANDATORY SERVICE	MANDATORY SERVICE + ②	①+②	①	①+②+③
MACHINE COUNTER ↻						
DATE OF SERVICING ↻						

WHEN DUE ↻	1250 H	1500 H or 3 YEARS	1750 H	2000 H or 4 YEARS	2250 H	2500 H or 5 YEARS	2750 H
PERIODIC SERVICE ↻	①	①+②	①	①+②+③+④	①	①+②	①
MACHINE COUNTER ↻							
DATE OF SERVICING ↻							

WHEN DUE ↻	3000 H or 6 YEARS	3250 H	3500 H or 7 YEARS	3750 H	4000 H or 8 YEARS	4250 H	4500 H or 9 YEARS
PERIODIC SERVICE ↻	①+②+③	①	①+②	①	①+②+③+④	①	①+②
MACHINE COUNTER ↻							
DATE OF SERVICING ↻							

WHEN DUE ↻	4750 H	5000 H or 10 YEARS	5250 H	5500 H or 11 YEARS	5750 H	6000 H or 12 YEARS	6250 H
PERIODIC SERVICE ↻	①	①+②+③	①	①+②	①	①+②+③+④	①
MACHINE COUNTER ↻							
DATE OF SERVICING ↻							

#### ↻ ① 250H - PERIODIC SERVICE - EVERY 250 HOURS OF SERVICE

- |         |                                 |      |
|---------|---------------------------------|------|
| - CHECK | Angle gear box oil level .....  | 3-20 |
| - CHECK | Parking brake .....             | 3-20 |
| - CLEAN | Heating block check valve ..... | 3-20 |

## ➔ 2 500H - PERIODIC SERVICE - EVERY 500 HOURS OF SERVICE OR 1 YEAR

- CHECK	Countdown before "stationary lift truck" exhaust regeneration.....	3-22
- CHECK	Alternator belt tension.....	3-22
- CHECK	Hydraulic oil.....	3-22
- LUBRICATE	Parking brake lever mechanism.....	3-23
- REPLACE	Engine oil.....	3-23
- REPLACE	Engine oil filter.....	3-23
- REPLACE	Gear box oil filter.....	3-24
- REPLACE	Front axle differential oil.....	3-24
- REPLACE	Rear axle differential oil.....	3-24
- REPLACE	Hydraulic return oil filter cartridge.....	3-24
- REPLACE	Cabin fan filters.....	3-25
- CHECK	Fork wear *.....	3-25

*\* Consult your dealer.*

## ➔ 3 1000H - PERIODIC SERVICE - EVERY 1,000 HOURS OF SERVICE OR 2 YEARS

### **ALSO PERFORM THE 500 HOUR PERIODIC MAINTENANCE OPERATIONS.**

- CHECK	Seat belt.....	3-26
- CLEAN	Fuel tank.....	3-26
- REPLACE	Fuel tank breather.....	3-26
- REPLACE	Coolant.....	3-26
- REPLACE	Dry air filter cartridge.....	3-27
- REPLACE	Fuel pre-filter.....	3-28
- REPLACE	Fuel filter.....	3-28
- REPLACE	Alternator belt.....	3-28
- REPLACE	Gearbox oil.....	3-29
- CLEAN	Gearbox sump strainer.....	3-29
- REPLACE	Angle gear box oil.....	3-30
- REPLACE	Front wheel reducer oil.....	3-30
- REPLACE	Rear wheel reducer oil.....	3-30
- CHECK	Engine silent blocks *.....	3-31
- CHECK	Valve lash *.....	3-31
- CHECK	Gearbox silent blocks *.....	3-31
- CHECK	Gear box controls *.....	3-31
- CHECK	Brake system pressure *.....	3-31
- CHECK	Boom pad wear *.....	3-31
- CHECK	Condition of wiring harnesses and cables *.....	3-31
- CHECK	Lights and signals *.....	3-31
- CHECK	Warning indicators *.....	3-31
- CHECK	Condition of the rear-view mirrors *.....	3-31
- CHECK	Cabin structure *.....	3-31
- CHECK	Frame structure *.....	3-31
- CHECK	Attachment carriage *.....	3-31
- CHECK	Condition of attachments *.....	3-31
- REPLACE	Brake fluid *.....	3-31
- BLEED	Brake circuit *.....	3-31
- ADJUST	Brake *.....	3-31

*\* Consult your dealer.*

## 4 2000H - PERIODIC SERVICE - EVERY 2,000 HOURS OF SERVICE OR 4 YEARS

### ALSO PERFORM THE 500 HOUR AND 1,000 HOUR PERIODIC MAINTENANCE OPERATIONS.

- CHECK	Wheel nut tightening torques .....	3-32
- REPLACE	Dry air filter safety cartridge .....	3-32
- REPLACE	Hydraulic oil .....	3-33
- CLEAN	Hydraulic oil tank suction strainer .....	3-33
- REPLACE	Hydraulic oil tank filter cap .....	3-33
- REPLACE	Distributor control head filter .....	3-33
- CHECK	Radiator * .....	3-34
- CHECK	Water pump and thermostat * .....	3-34
- CHECK	Alternator and starter * .....	3-34
- CHECK	Turbocharger * .....	3-34
- CHECK	Transmission pressures * .....	3-34
- CHECK	Steering * .....	3-34
- CHECK	Steering swivel joints * .....	3-34
- CHECK	Brake pad and brake disk wear * .....	3-34
- CHECK	Condition of boom assembly * .....	3-34
- CHECK	Bearings and bushings of the boom * .....	3-34
- CHECK	Condition of hoses and flexible pipes * .....	3-34
- CHECK	Condition of cylinders (leakage, rods) * .....	3-34
- CHECK	Hydraulic circuit pressures * .....	3-34
- CHECK	Bearings and bushings of the frame* .....	3-34
- CLEAN	Air conditioning (OPTION) * .....	3-34
- REPLACE	Compressor belt (Air Conditioning OPTION) * .....	3-34

*\* Consult your dealer.*

## OCCASIONAL MAINTENANCE AND OPERATION

### OCCASIONAL MAINTENANCE

- CLEAN	"Stationary lift truck" exhaust regeneration .....	3-36
- REPLACE	Wheels .....	3-36
- REPLACE	Battery .....	3-37
- ADJUST	Front headlights .....	3-37

### OCCASIONAL OPERATION

- TOW OR WINCH	Lift truck .....	3-38
- SLING	Lift truck .....	3-38
- TRANSPORT	Lift truck .....	3-39

## FILTERING ELEMENTS AND BELTS

### ➔ 2 500H - PERIODIC SERVICE - EVERY 500 HOURS OF SERVICE OR 1 YEAR

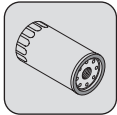

ENGINE OIL FILTER

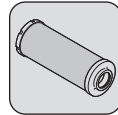

HYDRAULIC RETURN OIL FILTER CARTRIDGE

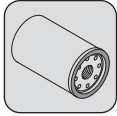

GEAR BOX OIL FILTER

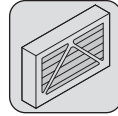

CAB FAN FILTER

### ➔ 3 1000H - PERIODIC SERVICE - EVERY 1,000 HOURS OF SERVICE OR 2 YEARS

*ALSO ADD FILTER CARTRIDGES FOR PERIODIC MAINTENANCE AFTER 500 HOURS OF SERVICE.*



DRY AIR FILTER CARTRIDGE

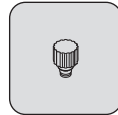

FUEL TANK BREATHER

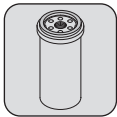

FUEL FILTER

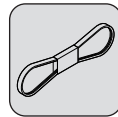

ALTERNATOR BELT



FUEL PRE-FILTER

### ➔ 4 2000H - PERIODIC SERVICE - EVERY 2,000 HOURS OF SERVICE OR 4 YEARS

*ALSO ADD FILTER CARTRIDGES FOR PERIODIC MAINTENANCE AT 500 HOURS AND 1,000 HOURS OF SERVICE.*

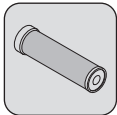

SAFETY DRY AIR FILTER CARTRIDGE

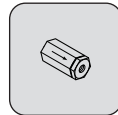

DISTRIBUTOR CONTROL HEAD FILTER

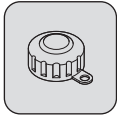

FILTER CAP FOR HYDRAULIC FLUID TANK

### ➔ OCCASIONAL MAINTENANCE

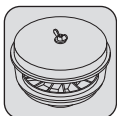

CYCLONIC PRE-FILTER

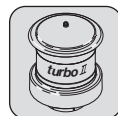

TURBO 2 SELF-CLEANING PRE-FILTER (OPTION)

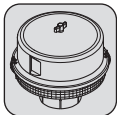

AUTOMATIC VACUUM-CLEANING PRE-FILTER (OPTION)

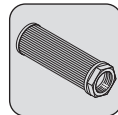

SUCTION STRAINER FOR HYDRAULIC OIL TANK

## LUBRICANTS AND FUEL

### ⚠ IMPORTANT ⚠

USE THE RECOMMENDED LUBRICANTS AND FUEL:

- For topping up, oils may not be miscible.
- For oil changes, MANITOU oils are perfectly appropriate.

### DIAGNOSTIC ANALYSIS OF OILS

If a service or maintenance contract has been set up with the dealer, a diagnostic analysis of engine, transmission and axle oils may be requested depending on the rate of use.

### (\*) REQUIRED FUEL SPECIFICATION

### ⚠ IMPORTANT ⚠

- Halve the engine maintenance intervals when using biodiesel B11 or above.
- Replace the water separator O-ring when switching from diesel fuel to biodiesel fuel such as HVO, B11 or higher.
- Pay special attention to the seals and fuel hoses when using HVO.

Use fuel that meets the following standards:

- Diesel fuel EN590
- Diesel fuel ASTM D975
- Biodiesel B10 to B20 EN16709
- Biodiesel HVO100 EN15940

### RECOMMENDATION

ENGINE		RECOMMENDATION									
DESCRIPTION	CAPACITY	-40 °F	-22	-4	+14	+32	+50	+68	+86	+104	+122 °F
		-40 °C	-30	-20	-10	0	+10	+20	+30	+40	+50 °C
ENGINE	9.5 Ql US (9 ℓ)	5W30									
		5W40									
		10W30									
		MANITOU EVOLOGY OIL 10W40 API CJ4									
		15W30									
		15W40									
		-40 °C	-30	-20	-10	0	+10	+20	+30	+40	+50 °C
COOLING CIRCUIT	22.2 Ql US (21 ℓ)	COOLANT -35 °C									
		-40 °C	-30	-20	-10	0	+10	+20	+30	+40	+50 °C
FUEL TANK	31.7 Gl US (120 ℓ)	DIESEL *									
TRANSMISSION		RECOMMENDATION									
DESCRIPTION	CAPACITY	-40 °F	-22	-4	+14	+32	+50	+68	+86	+104	+122 °F
		-40 °C	-30	-20	-10	0	+10	+20	+30	+40	+50 °C
GEARBOX	17.5 Ql US (16,6 ℓ)	MANITOU DX IIIG AUTOMATIC TRANSMISSION OIL									
		-40 °C	-30	-20	-10	0	+10	+20	+30	+40	+50 °C
ANGLE GEAR BOX	2.3 Ql US (2,2 ℓ)	MANITOU SAE80W90 MECHANICAL TRANSMISSION OIL									
FRONT AXLE		RECOMMENDATION									
DESCRIPTION	CAPACITY	-40 °F	-22	-4	+14	+32	+50	+68	+86	+104	+122 °F
		-40 °C	-30	-20	-10	0	+10	+20	+30	+40	+50 °C
FRONT AXLE DIFFERENTIAL	8.6 Ql US (8,1 ℓ)	SPECIAL MANITOU OIL FOR IMMERSED BRAKES									
		-40 °C	-30	-20	-10	0	+10	+20	+30	+40	+50 °C
FRONT WHEEL REDUCING GEAR	2 x 0.8 Ql US (2 x 0,8 ℓ)	MANITOU SAE80W90 MECHANICAL TRANSMISSION OIL									
		-40 °C	-30	-20	-10	0	+10	+20	+30	+40	+50 °C
FRONT WHEEL REDUCING GEAR PIVOTS		MANITOU BLACK MULTI-PURPOSE LUBRICANT									

<b>REAR AXLE</b>											
DESCRIPTION	CAPACITY	RECOMMENDATION									
REAR AXLE DIFFERENTIAL	8.6 Ql US (8,1 ℓ)	<b>SPECIAL MANITOU OIL FOR IMMERSED BRAKES</b>									
		-40 °F	-22	-4	+14	+32	+50	+68	+86	+104	+122 °F
		-40 °C	-30	-20	-10	0	+10	+20	+30	+40	+50 °C
REAR WHEEL REDUCING GEAR	2 x 0.8 Ql US (2 x 0,8 ℓ)	<b>MANITOU SAE80W90 MECHANICAL TRANSMISSION OIL</b>									
		-40 °C	-30	-20	-10	0	+10	+20	+30	+40	+50 °C
REAR WHEEL REDUCING GEAR PIVOTS		<b>MANITOU BLACK MULTI-PURPOSE LUBRICANT</b>									
		-40 °C	-30	-20	-10	0	+10	+20	+30	+40	+50 °C
REAR AXLE OSCILLATION		<b>MANITOU BLUE MULTI-PURPOSE LUBRICANT</b>									

<b>BRAKES</b>											
DESCRIPTION	CAPACITY	RECOMMENDATION									
BRAKE SYSTEM	1 Ql US (1 ℓ)	<b>MANITOU MINERAL BRAKE FLUID</b>									

<b>BOOM</b>											
DESCRIPTION	CAPACITY	RECOMMENDATION									
		-40 °F	-22	-4	+14	+32	+50	+68	+86	+104	+122 °F
		-40 °C	-30	-20	-10	0	+10	+20	+30	+40	+50 °C
BOOM PAD SLIDE PATHWAYS		<b>MANITOU BLACK MULTI-PURPOSE LUBRICANT</b>									
		-40 °C	-30	-20	-10	0	+10	+20	+30	+40	+50 °C
GREASING OF THE BOOM		<b>MANITOU BLUE MULTI-PURPOSE LUBRICANT</b>									

<b>HYDRAULICS</b>											
DESCRIPTION	CAPACITY	RECOMMENDATION									
		-40 °F	-22	-4	+14	+32	+50	+68	+86	+104	+122 °F
		-40 °C	-30	-20	-10	0	+10	+20	+30	+40	+50 °C
HYDRAULIC OIL TANK	29 GI US (110 ℓ)	ISO VG 100									
		ISO VG 68									
		<b>MANITOU ISO VG 46 HYDRAULIC OIL</b>									
		ISO VG 37									
		ISO VG 68									

<b>CAB</b>											
DESCRIPTION	CAPACITY	RECOMMENDATION									
		-40 °F	-22	-4	+14	+32	+50	+68	+86	+104	+122 °F
		-40 °C	-30	-20	-10	0	+10	+20	+30	+40	+50 °C
CAB DOOR		<b>MANITOU BLUE MULTI-PURPOSE LUBRICANT</b>									
WINDSCREEN WASHER TANK	2.1 Ql US (2 ℓ)	<b>WINDSCREEN WASHER LIQUID</b>									

**CHECK**

**Lift truck environment**

Carry out a general inspection around the lift truck:

- Fluid leaks or stains on the ground.
- Additional objects on the lift truck and in the cabin.
- Mounting and locking of the attachment.
- Mounting and adjustment of rear-view mirrors.
- Condition of the tyres to detect cuts, blisters, wear, etc.

**⚠ IMPORTANT ⚠**

*Follow the operator instructions (↩ 1 - OPERATING AND SAFETY INSTRUCTIONS: OPERATOR INSTRUCTIONS).*

**CLEANLINESS OF THE FORKLIFT**

- Cleanliness of lights and rear-view mirror.
- Excess dirt or build-up of material (e.g. straw, flour, sawdust, organic waste, etc.).
- On a daily basis, according to the conditions of use and the environment, the operator should ensure that the forklift truck is kept in a clean condition.
- Particular attention should be paid to accumulations of flammable materials (e.g. straw, flour, sawdust, organic waste, etc.) and fuel or lubricant leaks, as these significantly increase the risk of fire outbreaks.
- A regular inspection of the whole lift truck, especially the engine housing and the central part of the frame, is necessary to see how frequently it needs to be cleaned to prevent these potential accumulations of material or leakages.

**CHECK**

**Engine oil level**

Place the lift truck on level ground with the engine stopped, and let the oil settle in the sump.

- Open the engine cover.
- Pull out dipstick 1.
- Clean the dipstick and check the correct level between the two notches.
- If necessary, add oil (↩ LUBRICANTS AND FUEL) through the filler hole 2.
- Visually check that there is no leakage or seepage.



**CHECK**

**Cooling liquid level**

Place the lift truck on level ground with the engine stopped, and allow the engine to cool.

**⚠ IMPORTANT ⚠**

*To avoid any risk of spraying or scalding, wait until the engine has cooled down before removing the cooling system filler plug.*

*In the event of an emergency, it is possible to use water as the coolant, but then proceed to drain the coolant circuit as quickly as possible.*

- Open the engine cover.
- The liquid must be at the MAX. level on the expansion tank 1.
- If necessary, add coolant (↩ LUBRICANTS AND FUEL) through the filler hole 2.
- Visually check that there is no leakage or seepage.



## CHECK

### Fuel pre-filter

#### ⚠ IMPORTANT ⚠

*Carefully clean the outside of the pre-filter and its holder, to prevent dust from getting into the system.*

- Open the engine cover.
- Disconnect electrical wiring harness 1 from the fuel pre-filter.
- Place a hose on the drain plug 2 and the other end in a container.
- Unscrew the drain plug 2 by two turns.
- Allow the diesel fuel to flow out until it is free from impurities and water.
- Retighten drain plug 2 and reconnect the wiring harness 1.



## CLEAN

### Cyclonic pre-filter

The cleaning interval is given as a guide, however the pre-filter must be emptied and cleaned as soon as impurities reach the MAX level on the tank.

#### ⚠ IMPORTANT ⚠

*When cleaning, take care not to let impurities into the dry air filter.*

- Loosen nut 1 remove cover 2 and empty the tank.
- Clean the pre-filter unit with a clean dry cloth and reassemble the unit.



## 50H - WEEKLY SERVICE OR EVERY 50 HOURS OF SERVICE

### CHECK

### Gear box oil level

Park the lift truck on level ground with the boom raised, the engine stopped. Carry out the check within 5 minutes of the engine being stopped.

#### ⚠ IMPORTANT ⚠

*Raise the boom and place the boom safety wedge on the rod of the lifting cylinder (↖ 1 - INSTRUCTIONS AND SAFETY RECOMMENDATIONS: LIFT TRUCK MAINTENANCE INSTRUCTIONS).*

- Remove the plastic cap 1.
- Pull out dipstick 2.
- Wipe the dipstick and check the correct level between the two MIN and MAX marks.
- If necessary, add oil (↖ 1000H: REPLACE Gear box oil).
- Visually check that there is no leakage or seepage.



### CHECK

### Tyre pressures

### CHECK

### Wheel nut tightening

#### ⚠ IMPORTANT ⚠

*Check that the air hose is correctly connected to the tyre valve before inflating and keep all persons at a distance during inflation. Follow the recommended tyre pressures.*

- Check the wheel nut tightening. Non-compliance with this instruction can lead to deterioration and breakage of the wheel bolts and distortion of the wheels.
- Check and restore tyre pressures if necessary (↖ 2 - DESCRIPTION: TYRES).

NOTE: There is an OPTIONAL wheel tool kit.

### CHECK

### Front axle differential seal

### CHECK

### Rear axle differential seal

Place the lift truck on level ground with the engine stopped.

- Visually check that there is no leakage or seepage.
- If there is any leakage or seepage, check the level:
  - Remove the level plug 1, the oil should be flush with the edge of the hole.
  - If necessary, add oil (↖ LUBRICANTS AND FUEL) through the filler hole 2.
  - Refit and tighten the level plug (tightening torque 25 - 36 ft-lbs 34 - 49 N.m).

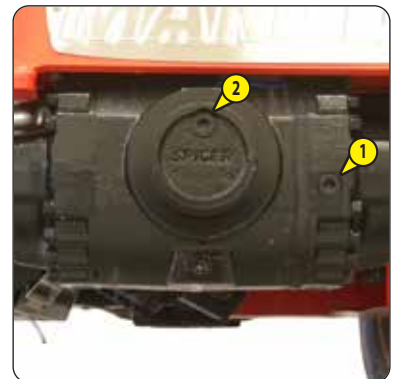

### CHECK

### Front wheel reducer seals

### CHECK

### Rear wheel reducer seals

Place the lift truck on level ground with the engine stopped.

- Visually check that there is no leakage or seepage.
- If there is any leakage or seepage, check the level:
  - Place level plug 1 in a horizontal position.
  - Remove the level plug; the oil should be flush with the edge of the opening.
  - If necessary, add oil (↖ LUBRICANTS AND FUEL) by the same hole.
  - Refit and tighten the level plug (tightening torque 25 - 36 ft-lbs 34 - 49 N.m).



## CHECK

### Brake fluid level

Place the lift truck on level ground.

#### **⚠ IMPORTANT ⚠**

*If the brake oil level is abnormal consult your dealer.*

- Loosen screw 1 and lift up the brake fluid and windshield washer tank access panel 2.
- Check tank 3. The correct level should be at the MAX. level on the tank.
- Visually check that there is no leakage or seepage.
- If necessary, add oil (⚠ LUBRICANTS AND FUEL).
- Pivot the tank 3 to access filler cap 4.
- Remove the cap 4.
- Add oil through filler port.
- Refit the cap.



## CHECK

### Boom pad slide pathways

To preserve optimum operation, the pad slide pathways should be correctly lubricated:

#### **⚠ IMPORTANT ⚠**

**MANDATORY GREASING OF THE BOOM AFTER:**

*Cleaning the boom, especially after using high pressure cleaner.*

*The forklift has been unused for a long period of time.*

- Fully extend the boom.
- Check the condition of the surface of the pad slide pathways, surface run in (steel whitened) without traces of corrosion.
- If necessary lubricate the pad slide pathways (⚠ LUBRICANTS AND FUEL).
- Telescope the boom several times in order to spread the lubricant evenly.
- Remove the surplus lubricant.

#### **⚠ IMPORTANT ⚠**

*If the lift truck is used in an abrasive environment (dust, sand, coal) use lubricating varnish (MANITOU Part No.: 483536).*

*Consult your dealer.*



## CHECK

### Hydraulic oil level

Place the lift truck on level ground with the engine stopped, and the boom retracted and lowered as far as possible.

#### **⚠ IMPORTANT ⚠**

*Use a clean funnel and clean the underside of the oil drum before filling.*

- Check dipstick 1, the correct level must be at the level of the red dot.
- If necessary, add oil (☞ LUBRICANTS AND FUEL).
- Remove the cap 2.
- Add oil through filler port 2.
- Refit the cap.
- Visually check that there is no leakage or seepage.



## CHECK

### Windscreen washer liquid level

Place the lift truck on level ground.

- Loosen screw 1 and lift up the brake fluid and windscreen washer tank access panel 2.
- Visually check the level in the tank.
- If necessary add windscreen washer fluid (☞ LUBRICANTS AND FUEL).
- Remove the cap 3.
- Add windscreen washer liquid through filler port.
- Refit the cap.



## CLEAN

### Radiator cores

#### **⚠ IMPORTANT ⚠**

*In a polluting atmosphere, clean the radiator cores every day.*

*Do not use a water jet or high pressure steam as this could damage the fins.*

- Open the engine cover.
- If necessary, clean the intake grille on the engine bonnet.
- Using a soft cloth, clean the radiator cores in order to remove as much dirt as possible.
- Clean the radiator using a compressed air jet aimed from the engine towards the radiator, in the opposite direction to the cooling air flow.



When used in very dusty atmospheres there are pre-filtration elements (⇐ FILTER CARTRIDGES AND BELTS). The cartridge checking and cleaning interval must also be reduced.

**⚠ IMPORTANT ⚠**

*If the clogging indicator light comes on, this operation should be performed as soon as possible (maximum 1 hour).*

*Never operate the lift truck with the air filter removed or damaged.*

*Maintain a safety distance of 1.18 in (30 mm) between the jet of air and the cartridge to avoid tearing or piercing the cartridge.*

*The cartridge must not be blown through close to the air filter casing.*

*Never clean the cartridge by tapping it on a hard surface.*

*Protect your eyes during this operation.*

*Never wash a dry air filter cartridge.*

*Never clean the safety cartridge located inside the filter cartridge. Change it for a new one if it is clogged or damaged.*

- For the dismantling and refitting of the cartridge (⇐ 1000H: REPLACE Air filter cartridge).
- Clean the filter cartridge using a compressed air jet (max. pressure 43.5 psi (3 bars) directed from the top to the bottom and from the inside towards the outside at a minimum distance of 1.18 in (30 mm) from the cartridge wall.
- Cleaning is completed when there is no more dust on the cartridge.
- Clean the cartridge seal surface with a damp, clean lint-free cloth and grease with a silicone lubricant (MANITOU part no.: 479292).
- Check visually the outer condition of the air filter and its mounts. Verify the condition of the hoses and their mounts also.

**⚠ IMPORTANT ⚠**

*In a polluting atmosphere, clean the radiator core every day.*

*Do not use a water jet or high-pressure steam as this could damage the condenser fins.*

- Remove the protective grid 1 and clean it if necessary.
- Visually check whether the condenser is clean and clean it if necessary.
- Clean the condenser using a compressed air jet aimed in the same direction as the air flow.
- Clean with the fans running for best results.



To be carried out weekly, if the lift truck has been operated for less than 50 hours during the week.

**⚠ IMPORTANT ⚠**

*In the event of prolonged use in an extremely dusty or oxidising atmosphere, reduce this interval to 10 hours of service or every day.*

Clean, then lubricate the following points with grease (← LUBRICANTS AND FUEL) and remove the surplus.

**BOOM**

- 1 - Lubricators of the boom pin (2 lubricators).
- 2 - Lubricators of the carriage pin (2 lubricators).
- 3 - Lubricator of the tilting cylinder foot pin (1 lubricator).
- 4 - Lubricator of the tilt cylinder head axle (1 lubricator).
- 5 - Lubricator of the lifting cylinder foot pin (1 lubricator).
- 6 - Lubricator of the lifting cylinder head pin (1 lubricator).
- 7 - Lubricator of the compensation cylinder foot pin (1 lubricator).
- 8 - Lubricator of the compensation cylinder head pin(1 lubricator).

**CAB DOOR**

- 9 - Door lubricators (4 lubricators).

**FRONT AND REAR WHEEL REDUCTION GEAR PIVOTS**

- 10 - Lubricators of the wheel reduction gear pivot pins (8 lubricators).

**REAR AXLE OSCILLATION**

- 11 - Rear axle oscillation lubricators (2 lubricators).

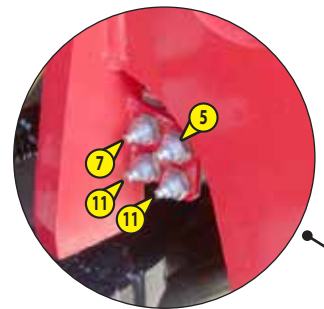

**OPTION**





## ➔ 1 250H - PERIODIC SERVICE - EVERY 250 HOURS OF SERVICE

### CHECK

#### Angle gear box oil level

Park the lift truck on level ground with the boom raised and the engine stopped.

#### ⚠ IMPORTANT ⚠

**Raise the boom and place the boom safety wedge on the rod of the lifting cylinder (↖ 1 - INSTRUCTIONS AND SAFETY RECOMMENDATIONS: LIFT TRUCK MAINTENANCE INSTRUCTIONS).**

- Pull out dipstick 1.
- Wipe the dipstick and check the correct level between the two MIN and MAX marks.
- If necessary, add oil (↖ 1000H: REPLACE Angle gear box oil).
- Visually check that there is no leakage or seepage.



### CHECK

#### Parking brake

Place the lift truck on a slope of at least 15% with the rated load in the transport position.

- Check the tightening adjustment by locking the parking brake in position A.
- The adjustment is correct when the lift truck remains stationary on the slope.
- Adjust if necessary.
- Press the brake pedal, then release the parking brake in position B.
- Progressively tighten the end of the lever 1 and recheck braking.
- Repeat the operation until the correct braking adjustment is obtained.

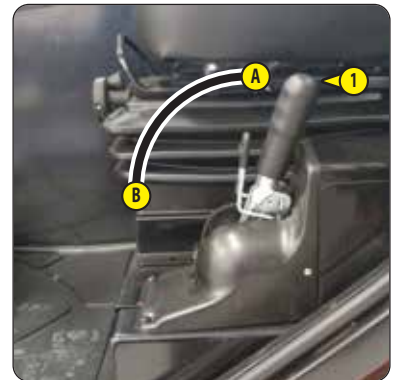

### CLEAN

#### Heating block check valve

- Since one-way valve 1 is located under the cab, it is possible for it to become obstructed with spattered mud for example. Clean if necessary.





## 🔄 500H - PERIODIC SERVICE - EVERY 500 HOURS OF SERVICE OR 1 YEAR

### **CHECK** Countdown before "stationary lift truck" exhaust regeneration

Depending on the countdown before the next regeneration, you can evaluate and, if necessary, perform a regeneration during the periodic 500-hour service (⏪ 3 - MAINTENANCE: OCCASIONAL MAINTENANCE).

- Short press button A to move from one screen to the next until the countdown before next regeneration screen is displayed (700h => 0h).



### **CHECK** Alternator belt tension

#### **⚠ IMPORTANT ⚠**

*If the compressor belt has to be changed, check the tension again after the first 20 hours of operation.*

- Open the engine cover.
- Remove the protective casing 1.
- Check the belt for signs of wear and cracks, and change if necessary (⏪ FILTER ELEMENTS AND BELTS).
- Check the belt tension between the crankshaft and alternator pulleys.
- Under a normal pressure exerted with the thumb 10.12 lbs (45 N), the clearance should be approximately 0.39 in (10 mm).
- Adjust if necessary.
- Loosen the screws 2 and 3 by two to three thread turns.
- Tighten the screw 4 to tighten the belt to the tension required.
- Retighten the screws 2 (tightening torque 22 ft-lbs 30 N.m) and the screw 3 (tightening torque 31 ft-lbs 42 N.m).
- Refit the protective casing 1.

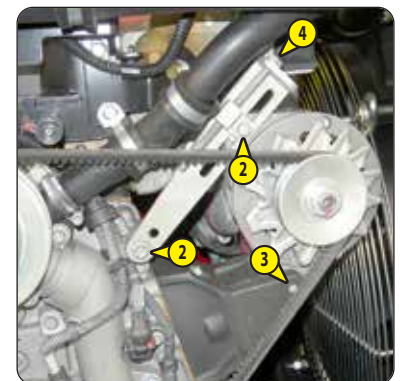

### **CHECK** Hydraulic oil

MANITOU offers a hydraulic oil analysis kit which might make it possible to delay the recommended deadline in the periodic maintenance schedule (2,000 hours). In this case we recommend an analysis of the hydraulic oil every 500 hours of service.

The oil analysis kit also makes it possible to confirm the oil quality so as to obtain a deadline of 2000 hours for specific uses causing constraints on the hydraulic circuit: extreme environmental conditions, use of the attachments with a very high hydraulic flow rate (such as a sweeper, or a concrete mixer).

- Order an oil analysis kit from your dealer.
- Upon receiving the kit, take a sample of oil and follow the instructions shown on the kit.
- According to the results, keep the analysis report or replace the hydraulic oil.

**Oil analysis kit (MANITOU Part No.: 958162)**



**LUBRICATE**

**Parking brake lever mechanism**

- Clean and lubricate the pivot pins 1 with grease (↩ LUBRICANTS AND FUEL).

**REPLACE**

**Engine oil**

**REPLACE**

**Engine oil filter**

Place the lift truck on level ground, let the engine run at idling speed for a few minutes, then stop the engine.

**⚠ IMPORTANT ⚠**

*Dispose of the drain oil in an ecological manner.*

*Tighten the oil filter by hand pressure only and lock the filter in place by a quarter turn.*

**DRAINING THE OIL**

- Open the engine cover.
- Remove access panels 1 and 2.

NOTE: When removing cover plates and hatches, clean the surrounding area and remove any accumulations of flammable materials.

- Place a container under the drain hole and unscrew the drain plug 3.
- Take drain hose 4.
- Place the end of the drain hose in the container and screw the hose fully to the drain connector 3.
- Remove the filler plug 5 to ensure correct drainage.

**REPLACEMENT OF THE FILTER**

- Unscrew and discard the engine oil filter 6, together with its seal.
- Clean the filter bracket with a clean, lint-free cloth.
- Lightly oil the seal before refitting the new oil filter (↩ FILTER CARTRIDGES AND BELTS) on its bracket (tightening torque 11 - 12 ft-lbs 15 - 17 N.m).

**FILLING WITH OIL**

- Remove, clean and refit drain hose 4.
- Refit and tighten the drain plug 3.
- Fill up with oil (↩ LUBRICANTS AND FUEL) through filler hole 5.
- Wait a few minutes to allow the oil to flow into the sump.
- Start the engine and let it run for a few minutes.
- Check for possible leaks from the drain plug and the oil filter.
- Stop the engine, wait a few minutes and check the correct level between the two marks on the dipstick 7.
- Top up the level if necessary.
- Refit access panels 1 and 2.



## REPLACE

### Gear box oil filter

#### ⚠ IMPORTANT ⚠

*Raise the boom and place the boom safety wedge on the rod of the lifting cylinder (↩ 1 - INSTRUCTIONS AND SAFETY RECOMMENDATIONS: LIFT TRUCK MAINTENANCE INSTRUCTIONS).*

*Tighten the gear box oil filter by hand pressure only and lock the filter in place by a quarter turn.*

- Remove the cover plate 1.

NOTE: When removing cover plates and hatches, clean the surrounding area and remove any accumulations of flammable materials.

- Unscrew and discard gear box oil filter 2.
- Carefully clean the filter head with a clean, lint-free cloth.
- Lightly oil the new seal and fit it to the filter.
- Fill up the new gear box oil filter (↩ FILTER CARTRIDGES AND BELTS) with oil (↩ LUBRICANTS AND FUEL).
- Refit the filter, making sure that the seal is correctly positioned and tightened.
- Refit cover plate 1.



## REPLACE

### Front axle differential oil

## REPLACE

### Rear axle differential oil

Place the lift truck on level ground with the engine stopped and the still warm differential oil.

#### ⚠ IMPORTANT ⚠

*Dispose of the drain oil in an ecological manner.*

- Place a container under drain plugs 1 and unscrew them.
- Remove level plug 2 and filling plug 3 to ensure that the oil is drained properly.
- Refit and tighten the drain plugs 1 (tightening torque 25 - 36 ft-lbs 34 - 49 N.m).
- Fill up with oil (↩ LUBRICANTS AND FUEL) through filler hole 3.
- The level is correct when the oil level is flush with the edge of opening 2.
- Check for any possible leaks at the drain plugs.
- Refit and tighten level plug 2 (tightening torque 25 - 36 ft-lbs 34 - 49 N.m) and filling plug 3 (tightening torque 25 - 36 ft-lbs 34 - 49 N.m).
- Repeat this operation for the rear axle differential.

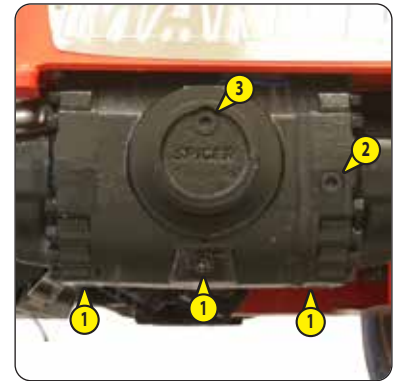

## REPLACE

### Hydraulic return oil filter cartridge

Stop the engine and release the pressure from the systems by operating the hydraulic controls.

#### ⚠ IMPORTANT ⚠

*Thoroughly clean the outside of the filter and its surroundings before any operation to prevent any risk of polluting the hydraulic system.*

*Tighten the body of the filter by hand pressure only and lock the body of the filter in place by a quarter turn.*

- Place a container under hydraulic return oil filter 1.
- Unscrew the body of the filter.
- Remove the hydraulic return oil filter cartridge and replace with a new one (↩ FILTER CARTRIDGES AND BELTS).
- Make sure that the cartridge is correctly positioned and refit the body of the filter.
- Wait a few moments while the oil flows into the container.



## **REPLACE**

### **Cabin fan filters**

- Unscrew thumbscrew 1 and remove protective casing 2.
- Remove the cab ventilation filter 3 and replace it with a new one (⇐ FILTER CARTRIDGES AND BELTS).
- Refit the protective casing.



## **CHECK**

### **Fork wear\***

*\* Consult your dealer.*

**CHECK**

**Seat belt**

**⚠ IMPORTANT ⚠**

*Under no circumstances must the lift truck be used if the seat belt is defective (fixing, locking, cuts, tears, etc.).  
Immediately repair or replace the seat belt.*

**SEAT BELT WITH TWO ANCHORING POINTS**

- Check the following points:
  - Fixing of the anchoring points on the seat.
  - Cleanness of the strap and the locking mechanism.
  - Triggering of the locking mechanism.
  - Condition of the strap (cuts, curled edges).

**REELED SEAT BELT WITH TWO ANCHORING POINTS**

- Check the points listed above together with the following points:
  - The correct winding of the belt.
  - Condition of the reel guards.
  - Roller locking mechanism when the strap is given a sharp tug.

NOTE: After an accident, replace the seat belt.

**CLEAN**

**Fuel tank**

**REPLACE**

**Fuel tank breather**

Place the lift truck on level ground with the engine stopped.

**⚠ IMPORTANT ⚠**

*While carrying out these operations, do not smoke or work near a flame.*

*Never try to carry out a weld or any other operation by yourself, this could provoke an explosion or a fire.*

- Inspect the parts of the fuel circuit and the tank liable to leak, both visually and by touch.
- In the event of a leak, contact your dealer.
- Place a container under drain plug 1 and unscrew the plug.
- Remove the filler plug 2 to ensure correct drainage.
- Rinse with ten litres of clean diesel through filler hole 3.
- Refit and tighten the drain plug 1 (tightening torque 21 - 29 ft-lbs 29 - 39 N.m).
- Unscrew the breather 4 and replace with a new one (⇐ FILTER CARTRIDGES AND BELTS) (tightening torque 3.7 ± 1.5 ft-lbs (5 ± 2 N.m)).
- Fill the fuel tank with clean diesel filtered through the filler port.
- Refit the filler plug.



**REPLACE**

**Coolant**

These operations are to be carried out as necessary or every 2 years at the beginning of winter. Place the lift truck on level ground with the engine stopped and cold.

**⚠ IMPORTANT ⚠**

*The engine does not contain any anti-corrosion elements and must be filled throughout the year with a mixture containing 25% ethylene glycol-based antifreeze.*

**DRAINING THE LIQUID**

- Open the engine cover.
- Remove access panel 1.



NOTE: When removing cover plates and hatches, clean the surrounding area and remove any accumulations of flammable materials.

- Place a container under radiator drain plug 2 and unscrew the plug.
- Take drain hose 3.
- Place the end of the drain hose in the container and screw the hose fully to the drain connector 2.
- Remove filler plug 4 from the expansion tank and fully open the heating control to ensure correct drainage.
- Let the cooling circuit drain entirely while ensuring that the ports do not get clogged.
- Check the condition of the hoses as well as the fastening devices and change the hoses if necessary.
- Rinse the circuit with clean water and use a cleaning agent if necessary.



### FILLING WITH COOLANT

- Remove, clean and refit drain hose 3.
- Refit and tighten the radiator drain plug 2.
- Slowly fill the circuit with coolant (⚠ LUBRICANTS AND FUEL) up to the MAX level of the expansion tank 5 through the filler hole.
- Refit the filler plug 4.
- Run the engine at idle for a few minutes.
- Check for any possible leaks.
- Refit access panel 1.
- Check the level and refill if necessary.



### REPLACE

#### Dry air filter cartridge

In case of use in a heavily dust laden atmosphere, there are pre-filtration cartridges, (⚠ FILTER CARTRIDGES AND BELTS). Also, the checking and cleaning periodicity of the cartridge must be reduced (up to 250 hours in a very dusty atmosphere and with pre-filtration).

#### ⚠ IMPORTANT ⚠

*Change the cartridge in a clean location, with the engine stopped.  
Never operate the lift truck with a cartridge removed or damaged.*

- Open the engine cover.
- Loosen the locks and remove cover 1.
- Gently remove the cartridge 2 to reduce dust falling as far as possible.
- Leave the safety cartridge in place.
- Carefully clean the following parts with a damp, clean lint-free cloth.
  - The inside of the filter and cover.
  - The inside of the filter inlet hose.
  - The gasket surfaces in the filter and in the cover.
- Check pipes and connections between the air filter and the engine and the connection and state of the clogging indicator on the filter.
- Before fitting check the condition of the new cartridge (⚠ FILTER CARTRIDGES AND BELTS).
- Insert the cartridge in the filter axis and push the cartridge pressing against the outer edge and not the centre.
- Reassemble the cover, guiding the valve downwards.

## REPLACE

### Fuel pre-filter

#### ⚠ IMPORTANT ⚠

*Carefully clean the outside of the pre-filter and its holder, to prevent dust from getting into the system.  
Tighten the fuel filter by hand only and lock in place by a quarter turn.*

- Switch off the lift truck's ignition.
- Open the engine cover.
- Close the diesel supply with valve 1.
- Disconnect electrical wiring harness 2 from the fuel pre-filter.
- Place a hose on the drain plug 3 and the other end in a container.
- Unscrew the drain plug 3 by two turns.
- Open bleed screw 4 to ensure proper emptying.
- Retighten bleed screw 4 once the pre-filter is emptied.
- Loosen pre-filter 5 and discard it, together with its seal.
- Clean the inside of the pre-filter head using a brush immersed in clean diesel oil.
- Refit a pre-filter and a new seal lubricated with clean diesel beforehand (⚡ FILTER CARTRIDGES AND BELTS).
- Reconnect electrical wiring harness 2 on the fuel pre-filter.
- Replace the fuel filter.



## REPLACE

### Fuel filter

#### ⚠ IMPORTANT ⚠

*Carefully clean the outside of the filter and its holder, to prevent dust from getting into the system.*

- Unscrew and discard the fuel filter 1.
- Clean the inside of the filter head using a brush immersed in clean diesel oil.
- Refit a filter and a new seal lubricated with clean diesel beforehand (⚡ FILTER CARTRIDGES AND BELTS).
- Tighten the filter, making sure that the seal is correctly positioned (tightening torque 7.4 - 8.8 ft-lbs 10 - 12 N.m).
- Open the diesel supply with valve 2.
- Open the bleed screw 4 of the fuel pre-filter and the bleed screw 3 of the fuel filter.
- Switch on the lift truck's ignition, and close the bleed screw as soon as the diesel flows with no air.



## REPLACE

### Alternator belt

#### ⚠ IMPORTANT ⚠

*Check the belt tension again after the first 20 hours of operation.*

- Open the engine cover.
- Remove the protective casing 1.
- Loosen the screws 2 and 3 by two to three thread turns.
- Loosen the screw 4 to swivel the alternator assembly so as to free the belt 5.
- Remove the belt and replace with a new one (⚡ FILTER CARTRIDGES AND BELTS).
- Adjust the belt tension between the crankshaft and alternator pulleys.
- Tighten the screw 4 to tighten the belt to the tension required.
- Under a normal pressure exerted with the thumb (10.12 lbs (45 N), the clearance should be approximately 0.39 in (10 mm).
- Retighten the screws 2 (tightening torque 22 ft-lbs 30 N.m) and the screw 3 (tightening torque 31 ft-lbs 42 N.m).
- Refit the protective casing 1.

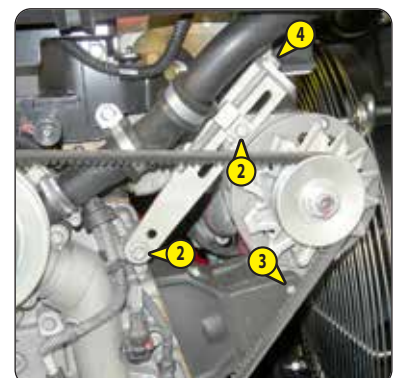

## REPLACE

## Gearbox oil

## CLEAN

## Gearbox sump strainer

Place the lift truck on level ground with the engine stopped and the gear box oil still warm.

### ⚠ IMPORTANT ⚠

*Raise the boom and place the boom safety wedge on the rod of the lifting cylinder (↖ 1 - INSTRUCTIONS AND SAFETY RECOMMENDATIONS: LIFT TRUCK MAINTENANCE INSTRUCTIONS).*

*Dispose of the drain oil in an ecological manner.*

### DRAINING THE OIL

- Place a container under drain plug 1 and under cover 2 and unscrew the drain plug.
- Remove the cover plate 3.

NOTE: When removing cover plates and hatches, clean the surrounding area and remove any accumulations of flammable materials.

- Remove dipstick 4 and unscrew filling plug 5 in order to ensure that the oil is drained properly.

### CLEANING THE STRAINER

- Remove cover 2 and set aside the O-ring joint and sealing washer.
- Allow the rest of the oil to drain away.
- Remove and clean the strainer using a compressed air jet.
- Clean the magnetic section on the plate.
- Refit the assembly and tighten up plate 2 (tightening torque 13 - 23 ft-lbs 18 - 31 N.m).

### FILLING WITH OIL

- Refit and tighten the drain plug 1 (tightening torque 25 - 40 ft-lbs 34 - 54 N.m).
- Fill up with oil (↖ LUBRICANTS AND FUEL) through the filler port 5 and refit the plug.
- Start the engine and let it run for a few minutes.
- Check any possible leaks from the drain plug or cover.
- Stop the engine, and within 5 minutes of the engine being stopped, check the correct level between the MIN and MAX marks on the dipstick 4.
- Top up the level if necessary.
- Refit cover plate 3.



## REPLACE

### Angle gear box oil

Place the lift truck on level ground with the engine stopped, the angle gear box oil still warm.

#### **⚠ IMPORTANT ⚠**

*Raise the boom and place the boom safety wedge on the rod of the lifting cylinder (↖ 1 - INSTRUCTIONS AND SAFETY RECOMMENDATIONS: LIFT TRUCK MAINTENANCE INSTRUCTIONS).*

*Dispose of the drain oil in an ecological manner.*

- Place a container under drain plug 1 and unscrew the plug.
- Remove dipstick 2 and unscrew filling plug 3 in order to ensure that the oil is drained properly.
- Refit and tighten the drain plug 1 (tightening torque 15 - 21 ft-lbs 20 - 29 N.m).
- Fill up with oil (↖ LUBRICANTS AND FUEL) through the filler port 3 and refit the plug.
- Check the correct level between the MIN and MAX marks on dipstick 2.
- Check for any possible leaks at the drain plug.

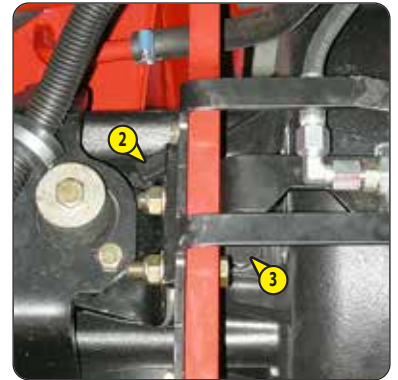

## REPLACE

### Front wheel reducer oil

## REPLACE

### Rear wheel reducer oil

Place the lift truck on level ground with the engine stopped and the reducers' oil still warm.

#### **⚠ IMPORTANT ⚠**

*Dispose of the drain oil in an ecological manner.*

- Drain and change the oil of each wheel reduction gear.
- Place drain plug 1 in position A.
- Place a container under the drain plug and unscrew the plug.
- Let the oil drain fully.
- Place the drain port in position B, i.e. in a level port.
- Fill up with oil (↖ LUBRICANTS AND FUEL) through level hole 1.
- The level is correct when the oil level is flush with the edge of the hole.
- Refit and tighten the drain plug (tightening torque 25 - 36 ft-lbs 34 - 49 N.m).

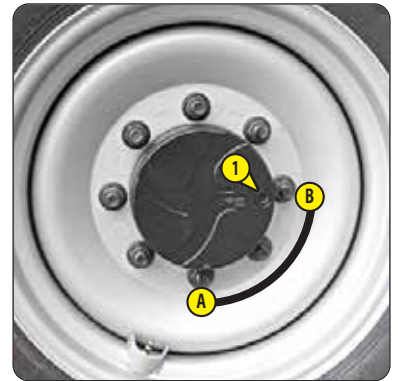

<b>CHECK</b>	<b>Engine silent blocks *</b>
<b>CHECK</b>	<b>Valve lash *</b>
<b>CHECK</b>	<b>Gearbox silent blocks *</b>
<b>CHECK</b>	<b>Gear box controls *</b>
<b>CHECK</b>	<b>Brake system pressure *</b>
<b>CHECK</b>	<b>Boom pad wear *</b>
<b>CHECK</b>	<b>Condition of wiring harnesses and cables *</b>
<b>CHECK</b>	<b>Lights and signals *</b>
<b>CHECK</b>	<b>Warning indicators *</b>
<b>CHECK</b>	<b>Condition of the rear-view mirrors *</b>
<b>CHECK</b>	<b>Cabin structure *</b>
<b>CHECK</b>	<b>Frame structure *</b>
<b>CHECK</b>	<b>Attachment carriage *</b>
<b>CHECK</b>	<b>Condition of attachments *</b>
<b>REPLACE</b>	<b>Brake fluid *</b>
<b>BLEED</b>	<b>Brake circuit *</b>
<b>ADJUST</b>	<b>Brake *</b>

**\* Consult your dealer.**

## ➔ 4 2000H - PERIODIC SERVICE - EVERY 2,000 HOURS OF SERVICE OR 4 YEARS

ALSO PERFORM THE 500 HOUR AND 1,000 HOUR PERIODIC MAINTENANCE OPERATIONS.

### CHECK

### Wheel nut tightening torques

- Check the condition of the tyres to detect cuts, blisters, wear, etc.
- Check the tightening torque of the wheel nuts with a torque wrench:
  - Front wheels =  $465 \pm 70$  ft-lbs ( $630 \pm 94$  N.m)
  - Rear wheels =  $465 \pm 70$  ft-lbs ( $630 \pm 94$  N.m)

### REPLACE

### Dry air filter safety cartridge

#### ⚠ IMPORTANT ⚠

*The safety cartridge replacement frequency is given for information only. It must be changed every second time the dry air filter cartridge is changed.*

- For the dismantling and refitting of the cartridge (↩ 1000H: REPLACE Air filter cartridge).
- Remove the dry air filter safety cartridge 1 carefully, to minimise dust fall.
- Clean the gasket surface on the filter with a damp, clean lint-free cloth.
- Check the condition of the new safety cartridge before fitting (↩ FILTER CARTRIDGES AND BELTS).
- Insert the cartridge in the filter axis and push the cartridge pressing against the outer edge and not the centre.



**REPLACE**

**Hydraulic oil**

**CLEAN**

**Hydraulic oil tank suction strainer**

**REPLACE**

**Hydraulic oil tank filter cap**

**REPLACE**

**Distributor control head filter**

Place the lift truck on level ground with the engine shut down, and the boom retracted and lowered as far as possible.

**⚠ IMPORTANT ⚠**

*Before any intervention, thoroughly clean the area surrounding the filter, the drain plugs and the suction cover on the hydraulic tank.*

*Dispose of the drain oil in an ecological manner.*

*Use a very clean container and funnel and clean the underside of the oil drum before filling.*

**DRAINING THE OIL**

- Place a container under drain plugs 1 and unscrew them.
- Remove level and filling plug 2 to ensure that the oil is drained properly and discard.

**CLEANING THE STRAINER**

- Remove the inlet cover 3.
- Remove and clean the suction strainer using a compressed air jet, check its condition and replace if necessary (⚡ FILTER CARTRIDGES AND BELTS).
- Refit the strainer and tighten the inlet cover 3 (tightening torque 60 ft-lbs 81 N.m) making sure the seal is in the correct position.

**REPLACING THE DISTRIBUTOR CONTROL HEAD FILTER**

**⚠ IMPORTANT ⚠**

*Be careful to mount the filter 6 in the same direction as the arrow.*

- Remove the half clamp 4.
- Undo the two couplings 5 and replace the filter 6.
- Refit half clamp 4.

**FILLING WITH OIL**

- Clean and refit the drain plugs 1 (tightening torque 21 - 29 ft-lbs 29 - 39 N.m).
- Fill up with oil (⚡ LUBRICANTS AND FUEL) through filler hole 7.
- Observe the oil level on dipstick 8, the oil level should be at the level of the red dot.
- Check for any possible leaks at the drain plugs.
- Replace filler plug with a new filler plug 2 (⚡ FILTER CARTRIDGES AND BELTS).



<b>CHECK</b>	<b>Radiator *</b>
<b>CHECK</b>	<b>Water pump and thermostat *</b>
<b>CHECK</b>	<b>Alternator and starter *</b>
<b>CHECK</b>	<b>Turbocharger *</b>
<b>CHECK</b>	<b>Transmission pressures *</b>
<b>CHECK</b>	<b>Steering *</b>
<b>CHECK</b>	<b>Steering swivel joints *</b>
<b>CHECK</b>	<b>Brake pad and brake disk wear *</b>
<b>CHECK</b>	<b>Condition of boom assembly *</b>
<b>CHECK</b>	<b>Bearings and bushings of the boom *</b>
<b>CHECK</b>	<b>Condition of hoses and flexible pipes *</b>
<b>CHECK</b>	<b>Condition of cylinders (leakage, rods) *</b>
<b>CHECK</b>	<b>Hydraulic circuit pressures *</b>
<b>CHECK</b>	<b>Bearings and bushings of the frame *</b>
<b>CLEAN</b>	<b>Air conditioning (OPTION) *</b>
<b>REPLACE</b>	<b>Compressor belt (Air Conditioning OPTION) *</b>

*\* Consult your dealer.*



### CLEAN

### "Stationary lift truck" exhaust regeneration

#### ⚠ IMPORTANT ⚠

*If you are performing regeneration during the periodic 500-hour service, do the regeneration before replacing the engine oil.*

- Park the lift truck in a safe and adequately ventilated place.
- Check the following points:
  - forward/reverse selector in neutral,
  - parking brake applied,
  - no action on the hydraulic control joystick,
  - boom in transport position,
  - idling speed,
- Check that the fuel level is sufficient.
- Start the lift truck and run the engine for a few minutes to bring it up to its normal operating temperature.
- Press the top of switch 1 and hold for at least two seconds to launch exhaust regeneration. Indicator lamp  coming on fixed and the engine speed increasing confirm the start of regeneration.
- The length of the exhaust regeneration procedure varies (between 40 and 50 minutes).



#### ⚠ IMPORTANT ⚠

*Exhaust regeneration must only be stopped if absolutely necessary.*

*Regeneration stops automatically if the operator:*

- activates the hydraulic control joystick,
- engages forward or reverse gear,
- switches off the engine,
- presses switch 1.

- When regeneration is complete, the indicator lamp  goes out and the countdown to next regeneration screen reverts to 700 hours (700h => 0h).

### REPLACE

### Wheels

For this operation, we advise you to use the hydraulic jack (MANITOU part no.: 505507) and the safety support prop (MANITOU part no.: 554772).

#### ⚠ IMPORTANT ⚠

*In the event of a wheel being changed on the public highway, secure the lift truck vicinity:*

- Stop the lift truck, if possible on firm, level ground.
- Stop the lift truck (⚠ 1 - OPERATING AND SAFETY INSTRUCTIONS: DRIVING INSTRUCTIONS UNLADEN AND LADEN).
- Switch on the hazard warning lights.
- Immobilise the lift truck in both directions on the axle opposite to the wheel to be changed.
- Unlock the nuts of the wheel to be changed.
- Place the jack under the flared axle tube, as near as possible to the wheel and adjust the jack.
- Raise the wheel until it is clear of the ground and place the safety support under the axle.
- Completely unscrew the wheel nuts and remove them.
- Free the wheel by reciprocating movements and roll it to the side.
- Slip the new wheel on the wheel hub.
- Hand-tighten the nuts, grease them if necessary.
- Remove the safety support and lower the lift truck with the jack.
- Tighten the wheel nuts with a torque wrench (⚠ 2000H - PERIODIC SERVICE - EVERY 2,000 HOURS OF SERVICE OR EVERY 4 YEARS) for the tightening torque.



## REPLACE

## Battery

### ⚠ IMPORTANT ⚠

Operate the battery cut-off for a minimum of 30 seconds after having switched off the ignition with the ignition key.  
Handling and servicing a battery can be dangerous, take the following precautions:

- Wear protective goggles.
  - Keep the battery horizontal.
  - Never smoke or work near a naked flame.
  - Work in a well-ventilated area.
- In the event of electrolyte being spilled onto the skin or splashed in the eyes, rinse thoroughly with cold water for 15 minutes and call a doctor.

- Remove the protective casing 1.
- Bring a backup battery of the same type as that of the lift truck, together with battery cables.
- Connect the back-up battery, respecting the polarity (-) (+).
- Start the lift truck and remove the cables as soon as the engine is running.

### ⚠ IMPORTANT ⚠

Raise the boom and place the boom safety wedge on the rod of the lifting cylinder (⚠ 1 - INSTRUCTIONS AND SAFETY RECOMMENDATIONS: LIFT TRUCK MAINTENANCE INSTRUCTIONS).

- Change the battery 2.



## ADJUST

## Front headlights

### RECOMMENDED SETTING

(according to standard ECE-76/756 76/761 ECE20)

Adjustment of -2 % of the dipped beam harness relative to the horizontal axis of the headlight.

### ADJUSTMENT PROCEDURE

- Place the unladen lift truck in the transport position and perpendicular to a white wall on flat, level ground.
- Check the tyre pressures (⚠ 2 - DESCRIPTION: TYRES).
- Place the forward/reverse selector in neutral.

### CALCULATING THE HEIGHT OF THE DIPPED BEAM (H2)

- h1 = Height of the dipped beam in relation to the ground.
- h2 = Height of the adjusted beam.
- l = Distance between the dipped beam and the white wall.

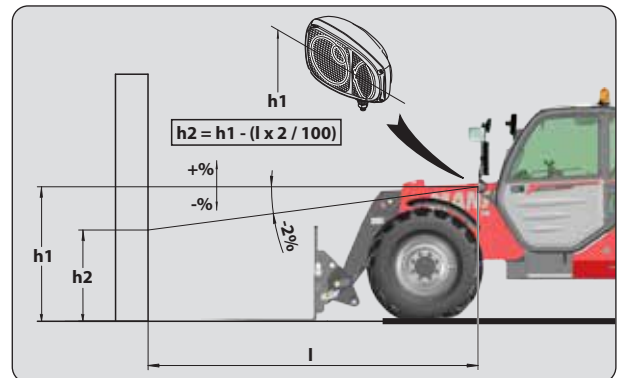

#### ⚠ IMPORTANT ⚠

*Do not tow the lift truck at more than 9.32 mph (15 km/h), and abide by local traffic regulations.*

- Place the forward/reverse selector and the gear lever in neutral.
- Release the hand brake.
- Switch on the hazard warning lights.

Since there will be no steering or braking hydraulic assistance, operate the steering and pedal slowly, avoiding sudden or jerky movements.

### SLING

### Lift truck

- Take into account the position of the lift truck centre of gravity for lifting.

A = 56.30 in (1430 mm)	B = 54.33 in (1380 mm)	MT 733...
A = 57.09 in (1450 mm)	B = 53.54 in (1360 mm)	MT 933...

- Place the hooks in the fastening points 1 provided.

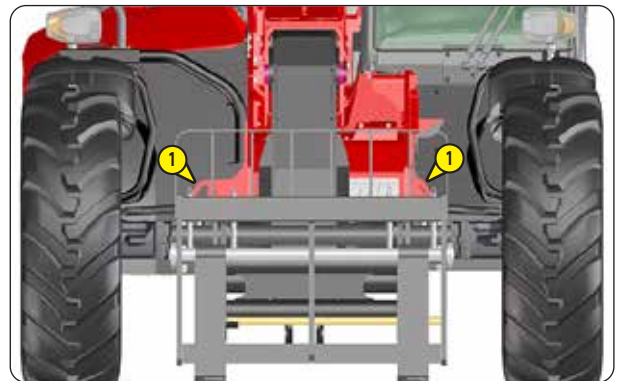
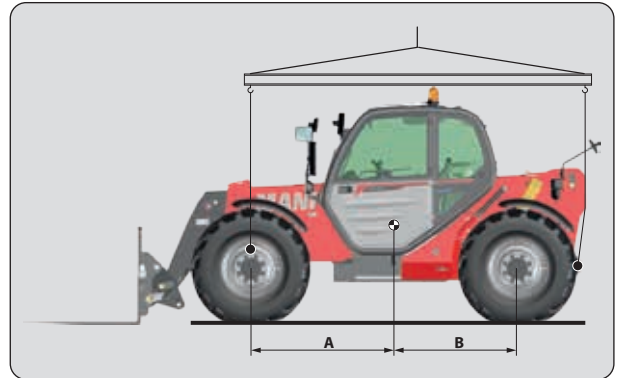

**⚠ IMPORTANT ⚠**

Ensure that the safety instructions associated with the flatbed are complied with before loading the lift truck and that the driver of the carrier vehicle is informed of the dimensions and the weight of the lift truck (<1 2 - DESCRIPTION: CHARACTERISTICS).

Ensure that the platform is of sufficient size and load capacity for transporting the lift truck. Check also the allowable ground contact pressure of the platform relative to the lift truck.

**⚠ IMPORTANT ⚠**

For lift trucks equipped with a turbo-charged engine, block off the exhaust outlet to avoid rotation of the turbo shaft without lubrication when transporting the vehicle.

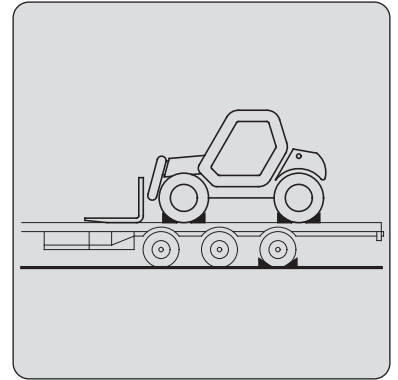

**LOADING THE LIFT TRUCK**

- Block the wheels of the platform.
- Attach the loading ramps to the platform in such a way as to give the shallowest possible ramp angle for the lift truck.
- Load the lift truck parallel to the platform.
- Stop the lift truck (<1 1 - OPERATING AND SAFETY INSTRUCTIONS: DRIVING INSTRUCTIONS UNLADEN AND LADEN).

**STOWING THE LIFT TRUCK**

- Fix the chocks to the flatbed at the front and at the back of each tyre.
- Also fix the chocks to the flatbed on the inside of each tyre.
- Secure the lift truck to the flatbed with straps, in the anchoring points 1 provided.
- In order to ensure the lift truck is securely lashed to the flatbed, observe the lashing angles ( $\alpha$ ) and ( $\beta$ ) and the resistance (LC) of the straps.
- Tighten the straps.

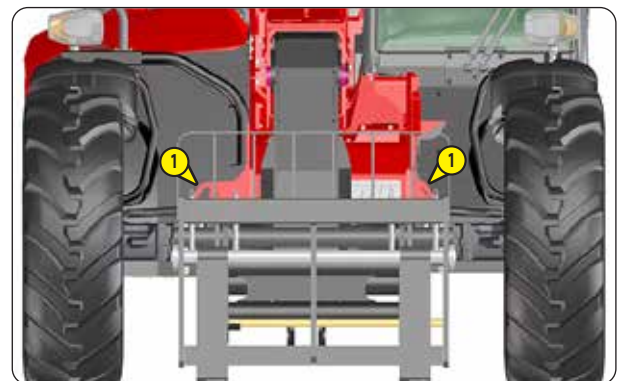
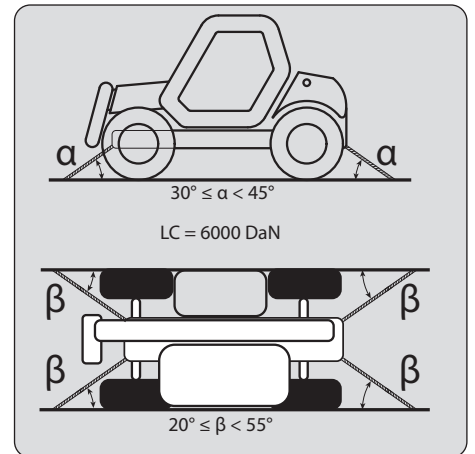



# ***4 - OPTIONAL ADAPTABLE ATTACHMENTS FOR THE RANGE***

## **4 - OPTIONAL ADAPTABLE ATTACHMENTS FOR THE RANGE**

<b><i>INTRODUCTION</i></b>	<b><i>4-3</i></b>
<b><i>PICKING UP THE ATTACHMENTS</i></b>	<b><i>4-4</i></b>
<b><i>TECHNICAL SPECIFICATIONS OF ATTACHMENTS</i></b>	<b><i>4-6</i></b>
<b><i>ATTACHMENT GUARDS</i></b>	<b><i>4-14</i></b>

## INTRODUCTION

- Your lift truck must be used with interchangeable equipment. These items are called: ATTACHMENTS.
- A wide range of attachments is available, guaranteed by MANITOU and designed to fit your lift truck perfectly.

### **⚠ IMPORTANT ⚠**

*Only attachments approved by MANITOU can be used on its lift trucks (← TECHNICAL CHARACTERISTICS OF ATTACHMENTS).*

*The manufacturer cannot be held responsible for any modifications or adaptations to attachments without its knowledge.*

- The attachments are delivered with a load chart concerning your lift truck. The operator's manual and the load chart should be kept in the places provided in the lift truck. For standard attachments, their use is governed by the instructions contained on this notice.

### **⚠ IMPORTANT ⚠**

*Maximum loads are defined by the capacity of a lift truck taking account of the attachment's mass and centre of gravity.*

*Should the attachment have a lower capacity than the lift truck, never exceed this limit.*

- Some particular uses require the adaptation of the attachment which is not provided in the price-listed options. Optional solutions exist, consult your dealer.

### **⚠ IMPORTANT ⚠**

*Depending on their size, certain attachments may, when the boom is lowered and retracted, come into contact with the front tyres and cause damage to them if excavation is activated in the direction of the discharge.*

**TO PREVENT THIS RISK, EXTEND THE TELESCOPE TO A SUFFICIENT EXTENT FOR THE PARTICULAR LIFT TRUCK AND ATTACHMENT SO THAT THIS CONTACT IS NOT POSSIBLE.**

## SUSPENDED LOAD

### **⚠ IMPORTANT ⚠**

*Suspended loads MUST be handled with a lift truck designed for that purpose (← 1 - OPERATING AND SAFETY INSTRUCTIONS: LOAD HANDLING INSTRUCTIONS: H - PICKING UP AND PUTTING DOWN A SUSPENDED LOAD).*

## USE OF BUCKETS

### **⚠ IMPORTANT ⚠**

*MT 733/933 lift trucks are essentially intended for handling, for which occasional use with the buckets CBC/CBR/CB4x1 is authorised (only with the boom fully retracted, in order to reduce stresses on the boom head), but under no circumstances for difficult applications (quarry, waste, cereals, agriculture, etc).*

## PICKING UP THE ATTACHMENTS

### 1 - ATTACHMENT WITHOUT HYDRAULICS AND HAND LOCKING DEVICE

#### FITTING AN ATTACHMENT

- Ensure that the attachment is in a position facilitating the locking to the carriage. If it is not correctly oriented, take the necessary precautions in order to move it safely.
- Check that the locking pin is in position in the bracket (Fig. A).
- Place the lift truck with the boom lowered in front of and parallel to the attachment, and tilt the carriage forwards (Fig. B).
- Bring the carriage under the locking tube of the attachment, slightly raise the boom, tilt the carriage backwards in order to position the attachment (Fig. C).
- Lift the attachment off the ground to facilitate locking.

#### MANUAL LOCKING

- Take the locking pin on the bracket (Fig. A) and lock the attachment (Fig. D). Do not forget to fit the cotter pin.

#### MANUAL UNLOCKING

- Proceed in the reverse order to MANUAL LOCKING, taking care to refit the locking pin in the bracket (Fig. A).

#### REMOVING THE ATTACHMENT

- Proceed in the reverse order to FITTING AN ATTACHMENT, taking care to store the attachment flat on the ground and in the closed position.

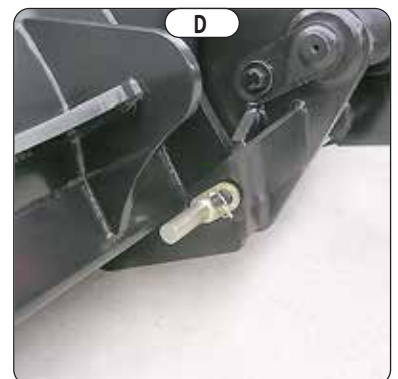
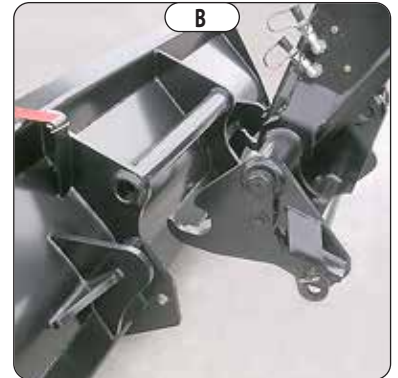
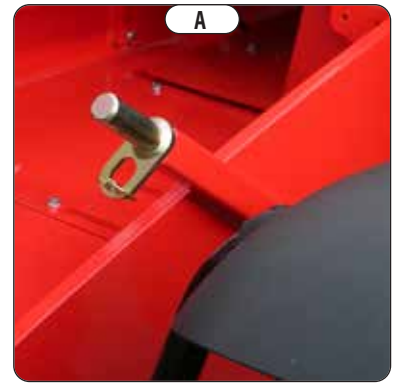

## 2 - HYDRAULIC ATTACHMENT AND MANUAL LOCKING DEVICE

### FITTING AN ATTACHMENT

- Ensure that the attachment is in a position facilitating the locking to the carriage. If it is not correctly oriented, take the necessary precautions in order to move it safely.
- Check that the locking pin is in position in the bracket (Fig. A).
- Place the lift truck with the boom lowered in front of and parallel to the attachment, and tilt the carriage forwards (Fig. B).
- Bring the carriage under the locking tube of the attachment, slightly raise the boom, tilt the carriage backwards in order to position the attachment (Fig. C).
- Lift the attachment off the ground to facilitate locking.

### MANUAL LOCKING AND CONNECTION OF THE ATTACHMENT

#### **⚠ IMPORTANT ⚠**

*Make sure that the rapid connectors are clean and protect the holes which are not used, with the caps provided.*

- Take the locking pin on the bracket and lock the attachment (fig. D). Do not forget to fit the cotter pin.
- Stop the engine and keep the ignition on the lift truck.
- Release the pressure in the attachment hydraulic circuit by moving switch 1 on the hydraulic controls lever backwards and forwards 4 or 5 times.
- Connect the quick-release couplers according to the logic of the attachment's hydraulic movements.

### MANUAL RELEASE AND DISCONNECTION OF THE ATTACHMENT

- Proceed in the reverse order of paragraph MANUAL LOCKING AND CONNECTION OF THE ATTACHMENT, taking care to refit the locking pin in the bracket.

### REMOVING THE ATTACHMENT

- Proceed in the reverse order to FITTING AN ATTACHMENT, taking care to store the attachment flat on the ground and in the closed position.

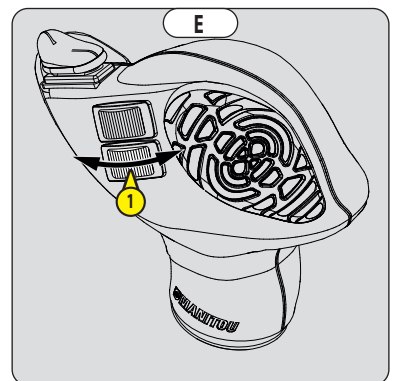
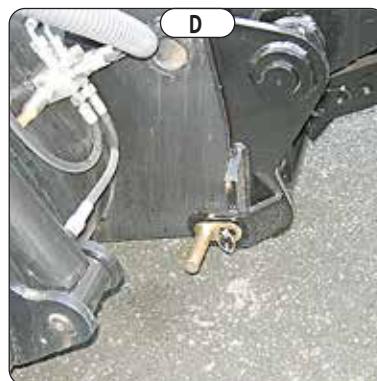
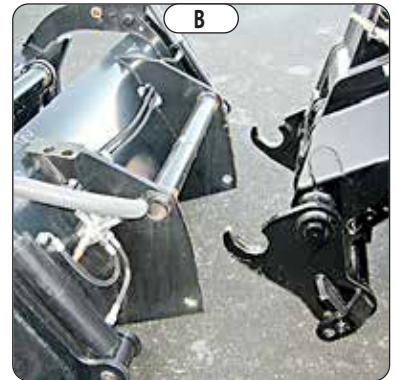
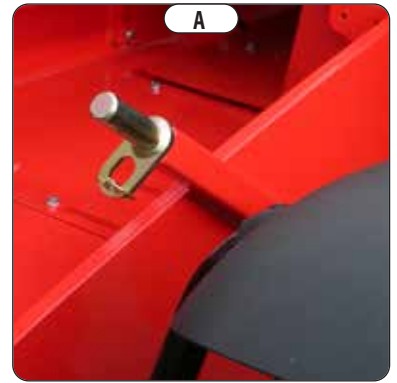

## TECHNICAL SPECIFICATIONS OF ATTACHMENTS

### FLOATING FORK CARRIAGE (first version)

	TFF 35 MT-1040	TFF 35 MT-1300
<b>PART No.</b>	<b>654093</b>	<b>654094</b>
Rated capacity	3500 kg	3500 kg
Width	1040 mm	1300 mm
Weight	300 kg	340 kg

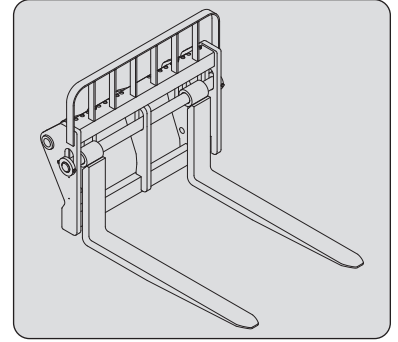

### FLOATING FORK SIDE-SHIFT CARRIAGE

	TFF 35 MT-1040 DL	TFF 35 MT-1300 DL
<b>PART No.</b>	<b>751543</b>	<b>751544</b>
Rated capacity	3500 kg	3500 kg
Side-shift	2x100 mm	2x100 mm
Width	1040 mm	1300 mm
Weight	345 kg	375 kg

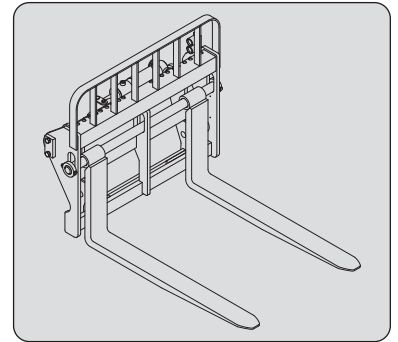

### FLOATING FORK

	<b>PART No.</b>	<b>415801</b>
Section		125x45x1200 mm
Weight		68 kg

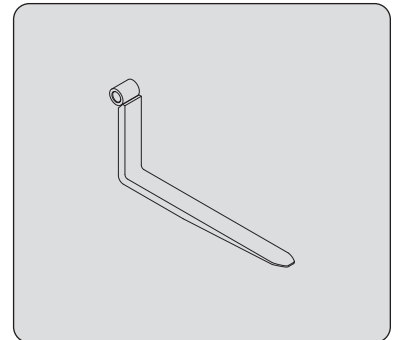

### FLOATING FORK CARRIAGE (second version)

	CAF 1040/4.1T	CAF 1300/4.1T
<b>PART No.</b>	<b>52722290</b>	<b>52810870</b>
Rated capacity	4100 kg	4100 kg
Spacing	493/1022 mm	245/1282 mm
Width	1160 mm	1420 mm
Weight	317 kg	355 kg

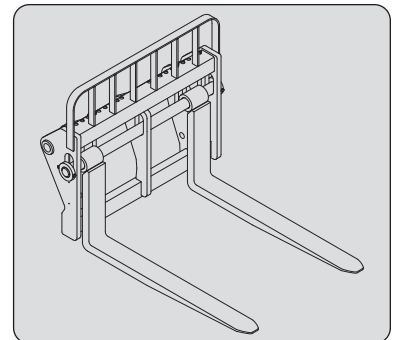

### FLOATING FORK

	<b>PART No.</b>	<b>52725383</b>
Section		100x50x1200 mm
Weight		62 kg

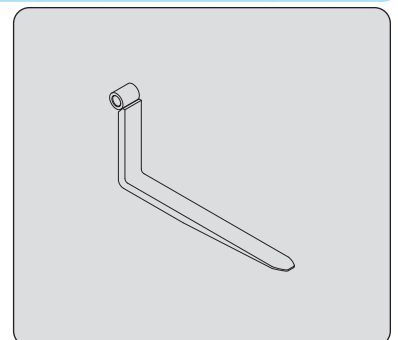

## FLOATING FORK CARRIAGE (third version)

	CAF 1040/4100 LB 52866338	CAF 1300/4100 LB 52866340
PART No.		
Rated capacity	4100 kg	4100 kg
Spacing	450/1020 mm	450/1280 mm
Width	1160 mm	1420 mm
Weight	335 kg	363 kg

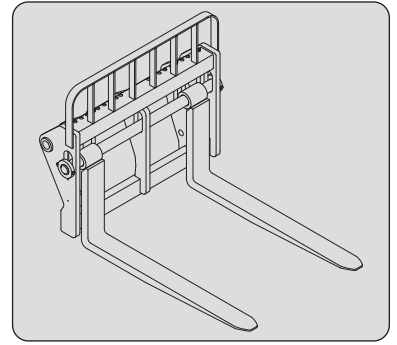

## FLOATING FORK

	PART No.	415947
Section		100x50x1200 mm
Weight		62 kg

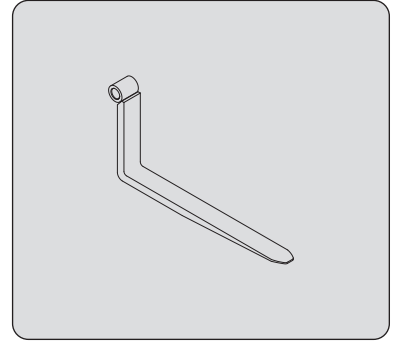

## FORK POSITIONER

	PART No.	CAF 1260/4500 P 52000273
Rated capacity		4500 kg
Spacing		275/1010 mm
Width		1260 mm
Weight		350 kg

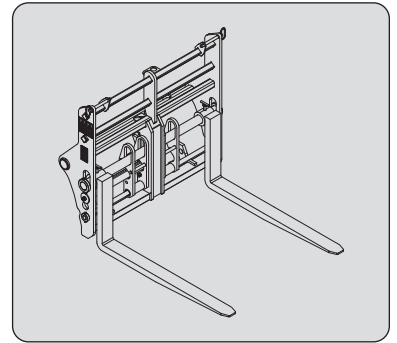

## FLOATING FORK

	PART No.	719611
Section		100x50x1200 mm
Weight		62 kg

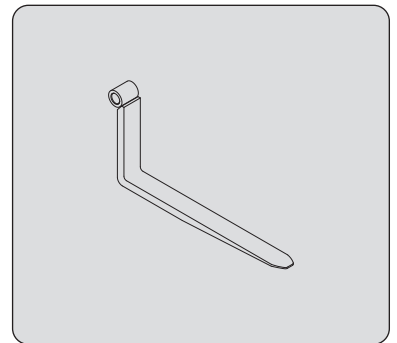

### STANDARDISED TILTING FORK CARRIAGE

	<b>PFB 35 N MT-1260 S2</b>	<b>PFB 35 N MT-1470 S2</b>	<b>PFB 35 N MT-1580 S2</b>
<b>PART No.</b>	<b>653744</b>	<b>653745</b>	<b>653746</b>
Rated capacity	3500 kg	3500 kg	3500 kg
Width	1260 mm	1470 mm	1580 mm
Weight	95 kg	120 kg	125 kg

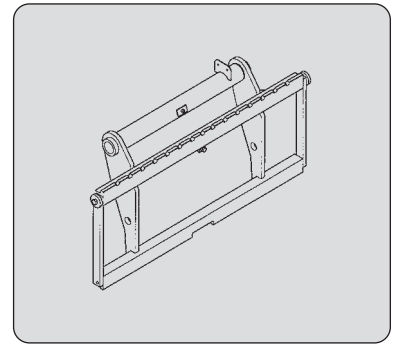

### STANDARDISED FORK

	<b>PART No.</b>	<b>415618</b>
Section		125x45x1200 mm
Weight		72 kg

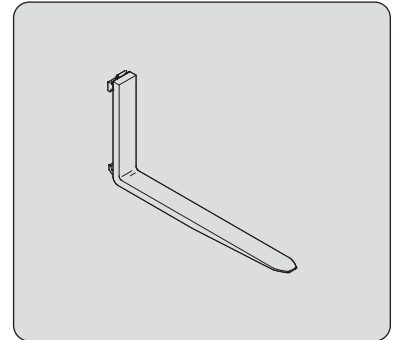

### STANDARDISED TILTING FORK CARRIAGE + STANDARDISED SIDE-SHIFT CARRIAGE

	<b>PFB 35 N 1260 DL</b>	<b>PFB 35 N 1580 DL</b>
<b>PART No.</b>	<b>52000101</b>	<b>52000102</b>
Rated capacity	3150 kg	3150 kg
Side-shift	2x100 mm	2x100 mm
Width	1260 mm	1580 mm
Weight	175 kg	300 kg

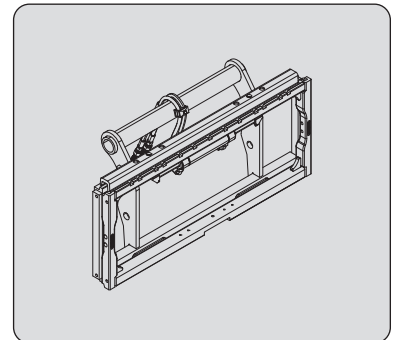

### STANDARDISED TILTING FORK CARRIAGE + LOAD BACK REST

	<b>PFB 35N 1260 LB</b>	<b>PFB 35N 1470 LB</b>
<b>PART No.</b>	<b>52000200</b>	<b>52000201</b>
Rated capacity	3500 kg	3500 kg
Width	1260 mm	1470 mm
Weight	130 kg	158 kg

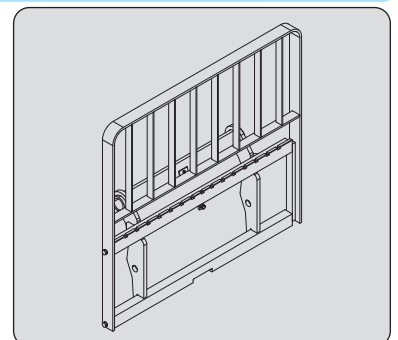

### STANDARDISED TILTING FORK CARRIAGE + STANDARDISED SIDE-SHIFT CARRIAGE + LOAD BACK REST

	<b>PFB 35 N 1260 DL/LB</b>
<b>PART No.</b>	<b>52000205</b>
Rated capacity	3150 kg
Side-shift	2x100 mm
Width	1260 mm
Weight	210 kg

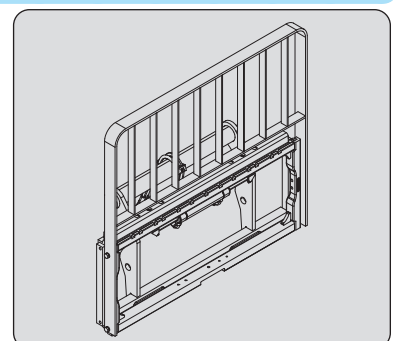



## BUILDING BUCKET

	<b>CBC 800 L2250</b>	<b>CBC 900 L2450</b>
<b>PART No.</b>	<b>654471</b>	<b>654470</b>
Rated capacity	814 ℓ	893 ℓ
Width	2250 mm	2450 mm
Weight	366 kg	391 kg

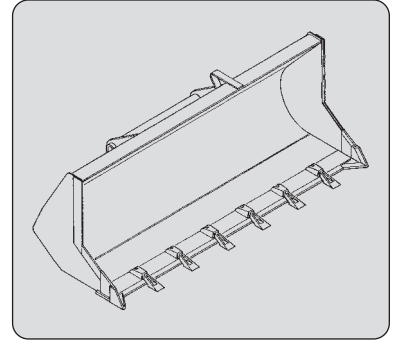

## LOADING BUCKET

	<b>CBR 900 L2250</b>	<b>CBR 1000 L2450</b>
<b>PART No.</b>	<b>653749</b>	<b>654716</b>
Rated capacity	904 ℓ	990 ℓ
Width	2250 mm	2450 mm
Weight	390 kg	410 kg

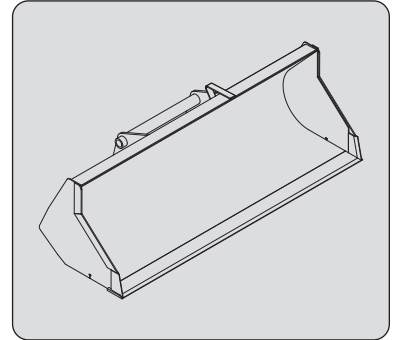

## CLAMSHELL BUCKET (REMOVABLE AND REVERSIBLE BLADE)

	<b>CBR 1000 L2450 LDR</b>
<b>PART No.</b>	<b>52000370</b>
Rated capacity	990 ℓ
Width	2450 mm
Weight	441 kg

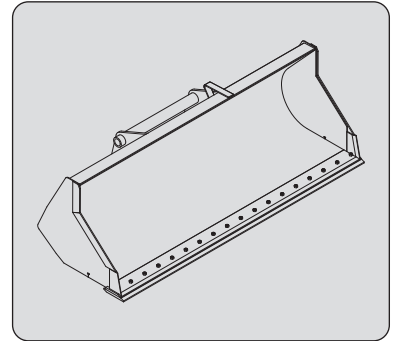

## MULTIPURPOSE BUCKET DISPLAY

	<b>CB4X1-700 L1950</b>	<b>CB4X1-850 L2300</b>	<b>CB4X1-900 L2450</b>
<b>PART No.</b>	<b>751402</b>	<b>751401</b>	<b>751465</b>
Rated capacity	700 ℓ	850 ℓ	900 ℓ
Width	1950 mm	2300 mm	2450 mm
Weight	640 kg	735 kg	765 kg

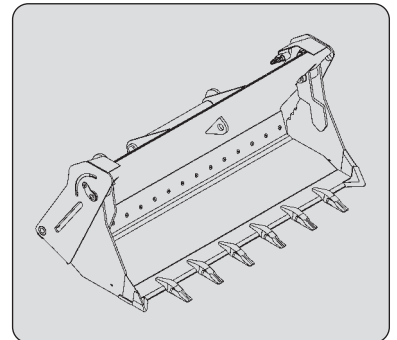

## CONCRETE BUCKET (ADAPTABLE ON FORKS) (first version)

	<b>BB 500 S4</b>	<b>BBH 500 S4</b>
<b>PART No.</b>	<b>654409</b>	<b>751462</b>
Rated capacity	500 ℓ/1300 kg	500 ℓ/1300 kg
Width	1100 mm	1100 mm
Weight	205 kg	220 kg

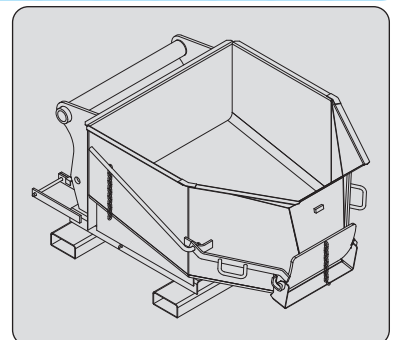

**CONCRETE BUCKET (ADAPTABLE ON FORKS)** (second version)

<b>PART No.</b>	<b>BB 500</b> <b>52000637</b>	<b>BBH 500</b> <b>52000638</b>
Rated capacity	500 ℓ/1200 kg	500 ℓ/1300 kg
Width	1216 mm	1100 mm
Weight	191 kg	200 kg

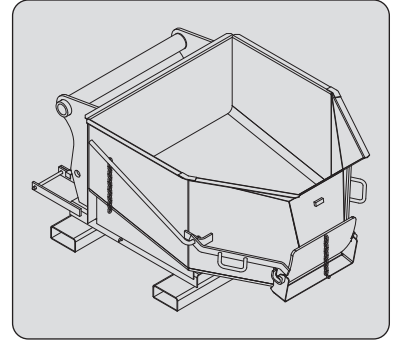
**CONCRETE BUCKET WITH SPOUT (ADAPTABLE ON FORKS)** (first version)

<b>PART No.</b>	<b>BBG 500 S4</b> <b>654411</b>	<b>BBHG 500 S4</b> <b>751464</b>
Rated capacity	500 ℓ/1300 kg	500 ℓ/1300 kg
Width	1100 mm	1100 mm
Weight	220 kg	235 kg

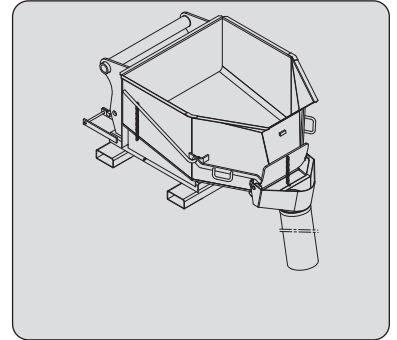
**CONCRETE BUCKET WITH SPOUT (ADAPTABLE ON FORKS)** (second version)

<b>PART No.</b>	<b>BBG 500</b> <b>52000639</b>	<b>BBHG 500</b> <b>52000640</b>
Rated capacity	500 ℓ/1300 kg	500 ℓ/1300 kg
Width	1220 mm	1100 mm
Weight	201 kg	210 kg

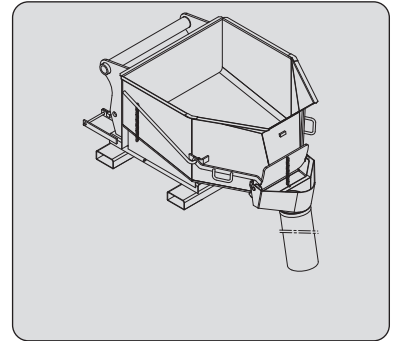
**SPOUT BUCKET (ADAPTABLE ON FORKS)** (first version)

<b>PART No.</b>	<b>GL 600 S2</b> <b>174373</b>	<b>GL 600 H S2</b> <b>784630</b>
Rated capacity	600 ℓ/1440 kg	600 ℓ/1440 kg
Weight	290 kg	290 kg

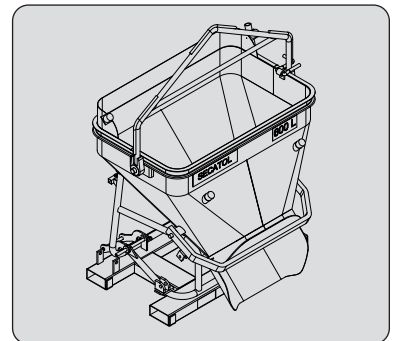
**SPOUT BUCKET (ADAPTABLE ON FORKS)** (second version)

<b>PART No.</b>	<b>GL 600</b> <b>52000528</b>	<b>GL 600 H</b> <b>52000529</b>
Rated capacity	600 ℓ/1440 kg	600 ℓ/1440 kg
Weight	230 kg	241 kg

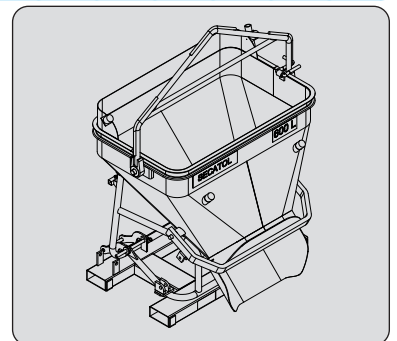

**JIB**

<b>PART No.</b>	<b>P 600 MT S3</b>
Rated capacity	600 kg
Weight	170 kg

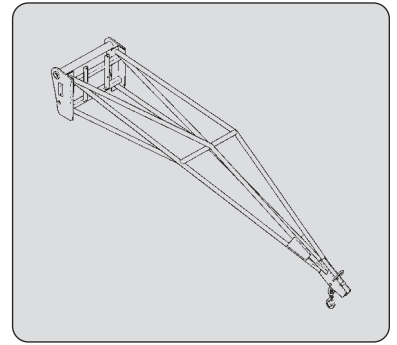
**JIB**

<b>PART No.</b>	<b>P 4000 MT S2</b>
Rated capacity	4000 kg/1200 kg
Weight	210 kg

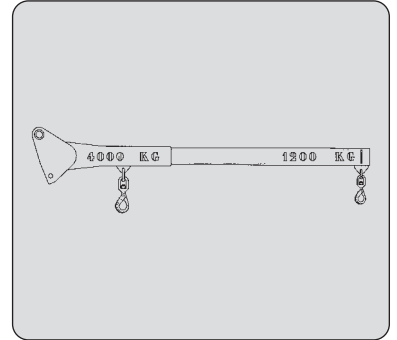
**CRANE JIB WITH WINCH (first version)**

<b>PART No.</b>	<b>PT 600 MT S6</b>
Rated capacity	600 kg
Weight	288 kg

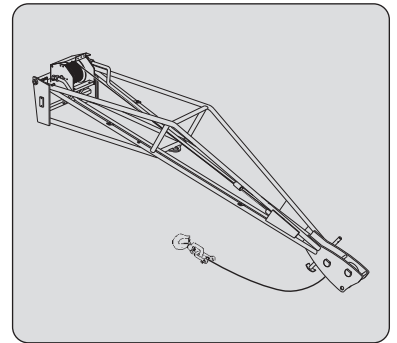
**CRANE JIB WITH WINCH (second version)**

<b>PART No.</b>	<b>PT 600</b>
Rated capacity	600 kg
Weight	320 kg

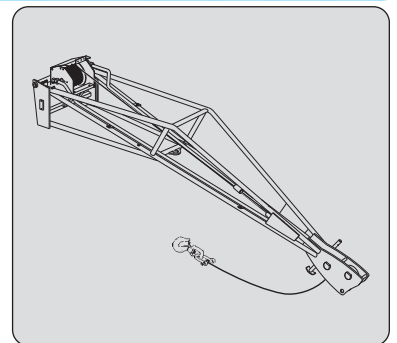
**CRANE JIB WITH WINCH (third version)**

<b>PART No.</b>	<b>PT 600</b>
Rated capacity	600 kg
Weight	278 kg

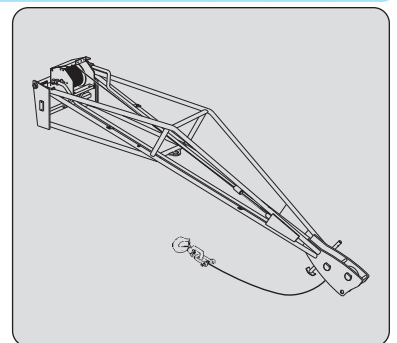

## 15°/15° MULTI-DIRECTIONAL CRANE JIB

	<b>PO 600 L2500</b>	<b>PO 1000 L1500</b>	<b>PO 2000 L1000</b>
<b>PART No.</b>	<b>784641</b>	<b>784642</b>	<b>784643</b>
Rated capacity	600 kg	1000 kg	2000 kg
Weight	320 kg	275 kg	255 kg

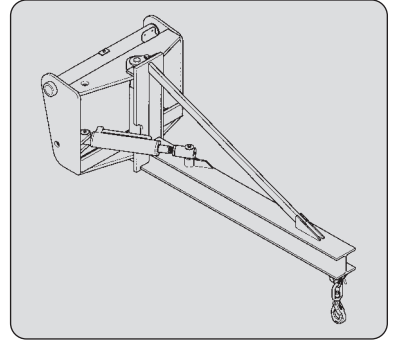

## JIB

	<b>PC 50</b>
<b>PART No.</b>	<b>708544</b>
Rated capacity	5000 kg
Weight	120 kg

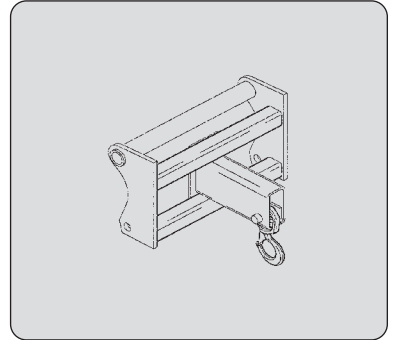

## JIB

	<b>JE 6000/600</b>
<b>PART No.</b>	<b>939995</b>
Rated capacity	600 kg
Weight	182 kg

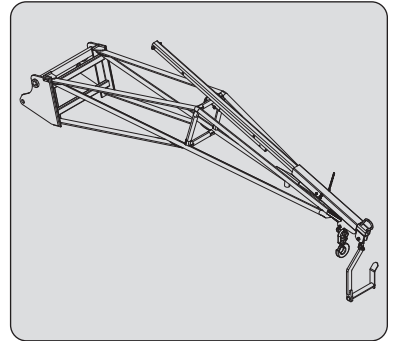

## BOOM CRANE WITH BIG BAG

	<b>HBB 1500/2400</b>
<b>PART No.</b>	<b>931627</b>
Rated capacity	2400 kg
Weight	186 kg

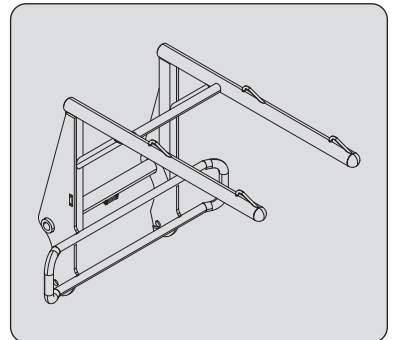

## ATTACHMENT GUARDS

### FORK GUARD

PART No. 227801

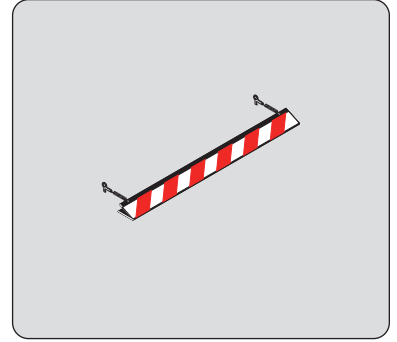

### FORK BLOCK FOR FLOATING FORK CARRIAGE

PART No. 261210

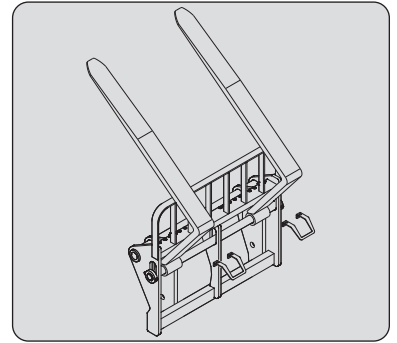

### BUCKET PROTECTOR

*Always ensure that the width of the protector you choose is less than or equal to the width of the bucket.*

Width	PART No. 206734	206732	206730
	1375 mm	1500 mm	1650 mm
Width	PART No. 235854	206728	206726
	1850 mm	1950 mm	2000 mm
Width	PART No. 223771	223773	206724
	2050 mm	2100 mm	2150 mm
Width	PART No. 206099	206722	223775
	2250 mm	2450 mm	2500 mm

