



**647874 EN-USM3 B102023**

MLT 841 145 PS+ Y ST5 S1  
MLT 1041 145 PS+ LY ST5 S1

**OPERATOR'S MANUAL**  
**(ORIGINAL INSTRUCTIONS)**

## IMPORTANT

*Carefully read and understand this instruction manual before using the lift truck.*

*It contains all information relating to operation, handling and lift truck equipment, as well as important recommendations to be followed.*

*This document also contains precautions for use, as well as information on the servicing and routine maintenance required to ensure the lift truck's continued safety of use and reliability.*

WHENEVER YOU SEE THIS SYMBOL IT MEANS:



**WARNING ! BE CAREFUL ! YOUR SAFETY OR THE SAFETY OF THE LIFT TRUCK IS AT RISK.**

- This manual has been produced on the basis of the equipment list and the technical characteristics given at the time of its design.
- The level of equipment of the lift truck depends on the options chosen and the country of sale.
- According to the lift truck options and the date of sale, certain items of equipment/functions described herein may not be available.
- Descriptions and figures are non binding.
- MANITOU reserves the right to change its models and their equipment without being required to update this manual.
- The MANITOU network, consisting exclusively of qualified professionals, is at your disposal to answer all your questions.
- This manual is an integral part of the lift truck.
- It is to be kept in its storage space at all times for ease of reference.
- Hand this manual to the new owner if the lift truck is resold.

## CALIFORNIA PROPOSITION 65 WARNINGS

### **WARNING**

This product can expose you to lead which is known to the State of California to cause cancer and birth defects or other reproductive harm.

For more information go to [www.P65Warnings.ca.gov](http://www.P65Warnings.ca.gov)

### **WARNING**

Breathing diesel engine exhaust exposes you to chemicals known to the State of California to cause cancer and birth defects or other reproductive harm.

- Always start and operate the engine in a well-ventilated area.
- If in an enclosed area, vent the exhaust to the outside.
- Do not modify or tamper with the exhaust system.
- Do not idle the engine except as necessary.

For more information go to [www.P65Warnings.ca.gov/diesel](http://www.P65Warnings.ca.gov/diesel)

## SILICA DUST HAZARD

Exposure to crystalline silica (found in sand, soil and rocks) has been associated with silicosis, a debilitating and often fatal lung disease. Comply with all applicable rules and regulations for the workplace. Wear approved respiratory protection or use water spray or other means if there is no other way to control the dust.

A Silica rule "29 CFR 1929.1153" by the U.S. Occupational Safety and Health (OSHA) indicates a significant risk of chronic silicosis for workers exposed to inhaled crystalline silica over a working lifetime. Refer to the rule for more information regarding exposure limits and hazard prevention.



1st ISSUE	A122020	
UPDATED	B-10/2023	0-0 1-14 ; 1-15 3-10 ; 3-18 ; 3-29

Manitou BF S.A Limited liability company with a Board of Directors.  
 Head office: 430, Rue de l'Aubinière - 44150 Ancenis - FRANCE  
 Share capital: 39,548,949 euros  
 857 802 508 RCS Nantes.  
 Tel: +33 (0)2 40 09 10 11  
 www.manitou.com

*This manual is for information purposes only. Any reproduction, copy, representation, recording, transfer, distribution, or other, in part or in whole, in any format is prohibited. The plans, designs, views, commentaries and instructions, even the document organization that are found in this document, are the intellectual property of MANITOU BF. Any violation of the aforementioned may lead to civil and criminal prosecution. The logos as well as the visual identity of the company are the property of MANITOU BF and may not be used without express and formal authorization. All rights are reserved.*

**Clause relating to restrictions on the use of database**

Manitou connected machines are equipped with boxes that collect technical data concerning the machines (such as geolocation, operating and component data). This data, which is organized, processed and enriched by Manitou's own algorithms and know-how, constitutes a protected database in accordance with Article L.341-1 of the French Intellectual Property Code.

It is strictly forbidden to have access to all or part of this database and to use this data (including in case of fortuitous access), except prior to Manitou's express authorization. In the event that Manitou authorises a user of a Manitou machine to access all or part of this database, Manitou as producer of this database only grants the user a personal, non-exclusive and non-transferable right to use the database, and only via access to a computer platform hosted on a server owned or controlled by Manitou.

In any case, are strictly prohibited:

- any extraction, reproduction, representation, reuse by making available to the public, diffusion, transfer, permanent or temporary, on any support, by any means and in any form whatsoever, of all or a qualitatively or quantitatively substantial part of the contents of the database,
- any extraction, reproduction, representation, reuse by making available to the public, dissemination, transfer, repeated and systematic extraction of qualitatively or quantitatively insubstantial parts of the contents of the database when these operations clearly exceed the conditions of normal use of the database by the user of the machine for his own needs,
- any use of a means of circumventing technical measures for the protection of databases or the source code of the software embedded in the boxes, in accordance with Article L.331-5 of the Intellectual Property Code.

**1 - OPERATING AND SAFETY INSTRUCTIONS**

**2 - DESCRIPTION**

**3 - MAINTENANCE**

**4 - OPTIONAL ADAPTABLE ATTACHMENTS FOR THE RANGE**



# ***1 - OPERATING AND SAFETY INSTRUCTIONS***

# 1 - OPERATING AND SAFETY INSTRUCTIONS

## INSTRUCTIONS TO THE COMPANY MANAGER

1-4

<b>THE SITE</b>	<b>1-4</b>
<b>THE OPERATOR</b>	<b>1-4</b>
<b>THE MACHINE</b>	<b>1-4</b>
A - SUITABILITY OF THE MACHINE FOR THE TASK . . . . .	1-4
B - ADAPTING THE MACHINE TO USUAL ENVIRONMENTAL CONDITIONS . . . . .	1-4
C - MODIFYING THE MACHINE . . . . .	1-5
D - FRENCH ROAD TRAFFIC RULES . . . . .	1-5
E - MACHINE CAB PROTECTION . . . . .	1-5
<b>INSTRUCTIONS</b>	<b>1-6</b>
<b>MAINTENANCE</b>	<b>1-6</b>

## INSTRUCTIONS FOR THE OPERATOR

1-8

<b>FOREWORD</b>	<b>1-8</b>
<b>GENERAL INSTRUCTIONS</b>	<b>1-8</b>
A - OPERATOR'S MANUAL . . . . .	1-8
B - AUTHORIZATION FOR USE IN FRANCE . . . . .	1-8
C - MAINTENANCE . . . . .	1-8
D - TIRES . . . . .	1-8
E - MODIFYING THE MACHINE . . . . .	1-9
F - LIFTING PEOPLE . . . . .	1-9
<b>OPERATING INSTRUCTIONS UNLADEN AND LADEN</b>	<b>1-10</b>
A - BEFORE STARTING UP THE MACHINE . . . . .	1-10
B - AVAILABLE IN THE DRIVER'S CAB . . . . .	1-10
C - ENVIRONMENT . . . . .	1-10
D - VISIBILITY . . . . .	1-11
E - STARTING THE MACHINE . . . . .	1-12
F - OPERATING THE MACHINE . . . . .	1-12
G - STOPPING THE MACHINE . . . . .	1-14
H - DRIVING THE MACHINE ON THE PUBLIC HIGHWAY . . . . .	1-15
<b>INSTRUCTIONS FOR HANDLING A LOAD</b>	<b>1-18</b>
A - CHOICE OF ATTACHMENTS . . . . .	1-18
B - WEIGHT OF LOAD AND CENTER OF GRAVITY . . . . .	1-18
C - LONGITUDINAL STABILITY INDICATOR . . . . .	1-18
D - TRANSVERSE ATTITUDE OF THE MACHINE . . . . .	1-19
E - PICKING UP A LOAD ON THE GROUND . . . . .	1-19
F - PICKING UP AND PUTTING DOWN A HIGH LOAD ON TIRES . . . . .	1-20
G - PICKING UP AND PUTTING DOWN A HIGH LOAD ON STABILIZERS . . . . .	1-22
H - PICKING UP AND PUTTING DOWN A SUSPENDED LOAD . . . . .	1-24
I - TRAVELING WITH A SUSPENDED LOAD . . . . .	1-24
<b>INSTRUCTIONS FOR USE AS A LOADER</b>	<b>1-25</b>
A - LOADING . . . . .	1-25
B - BACKFILLING . . . . .	1-25
<b>INSTRUCTIONS FOR USING THE MOBILE ELEVATING WORK PLATFORM</b>	<b>1-26</b>
A - AUTHORIZATION FOR USE . . . . .	1-26
B - SUITABILITY OF THE PLATFORM FOR THE JOB . . . . .	1-26
C - PROVIDED ON THE PLATFORM . . . . .	1-26
D - USING THE PLATFORM . . . . .	1-27
E - ENVIRONMENT . . . . .	1-28
F - MAINTENANCE . . . . .	1-28
<b>INSTRUCTIONS FOR USING THE RADIO-CONTROL</b>	<b>1-29</b>
HOW TO USE THE RADIO-CONTROL . . . . .	1-29
PROTECTIVE DEVICES . . . . .	1-29

## ***MACHINE MAINTENANCE INSTRUCTIONS***

**1-30**

<b>GENERAL INSTRUCTIONS</b>	<b>1-30</b>
<b>PLACING THE JIB SAFETY WEDGE</b>	<b>1-30</b>
FITTING THE WEDGE . . . . .	1-30
REMOVING THE WEDGE . . . . .	1-30
<b>MAINTENANCE</b>	<b>1-30</b>
MAINTENANCE LOGBOOK . . . . .	1-30
<b>LUBRICANT AND FUEL LEVELS</b>	<b>1-31</b>
<b>HYDRAULICS</b>	<b>1-31</b>
<b>ELECTRICITY</b>	<b>1-31</b>
<b>WELDING</b>	<b>1-31</b>
<b>WASHING THE MACHINE</b>	<b>1-31</b>
<b>TRANSPORTING THE MACHINE</b>	<b>1-31</b>

## ***PROLONGED MACHINE SHUTDOWN***

**1-32**

<b>INTRODUCTION</b>	<b>1-32</b>
<b>PREPARATION OF THE MACHINE</b>	<b>1-32</b>
<b>DEF (Diesel Exhaust Fluid) TANK</b>	<b>1-32</b>
<b>PROTECTING THE ENGINE</b>	<b>1-32</b>
<b>MACHINE PROTECTION</b>	<b>1-32</b>
<b>RETURNING THE MACHINE TO SERVICE</b>	<b>1-33</b>

## ***DISPOSING OF THE MACHINE***

**1-34**

<b>RECYCLING OF MATERIALS</b>	<b>1-34</b>
METALS . . . . .	1-34
PLASTICS . . . . .	1-34
RUBBER . . . . .	1-34
GLASS . . . . .	1-34
<b>ENVIRONMENTAL PROTECTION</b>	<b>1-34</b>
WORN OR DAMAGED PARTS . . . . .	1-34
USED OIL . . . . .	1-34
USED BATTERIES. . . . .	1-34

## INSTRUCTIONS TO THE COMPANY MANAGER

### THE SITE

Proper management of the machine's area of travel will reduce the risk of accidents:

- ground not unnecessarily uneven or obstructed,
- no excessive slopes,
- pedestrian traffic controlled, etc.

### THE OPERATOR

- Only qualified, authorized personnel can use the machine. This authorization is given in writing by the appropriate person in the establishment where the machine is to be used and must be carried permanently by the operator.

#### **⚠ IMPORTANT ⚠**

*Experience has shown that there are a number of inappropriate ways in which the machine might be operated. Such foreseeable misuse, of which the main examples are listed below, are strictly forbidden.*

*- The foreseeable abnormal behavior resulting from ordinary negligence, but not from any intentional misuse of the equipment.*

*- The reflex reactions of a person in the event of a malfunction, incident, fault, etc. during operation of the machine.*

*- Behavior resulting from application of the "principle of least effort" when performing a task.*

*- For certain machines, the foreseeable behavior of such persons as: apprentices, teenagers, handicapped persons, trainees tempted to drive a machine, operators tempted to operate a machine to win a bet, in competition or for their own personal experience.*

*The person in charge of the equipment must take these criteria into account when assessing whether or not a person will make a suitable driver.*

### THE MACHINE

#### A - SUITABILITY OF THE MACHINE FOR THE TASK

- MANITOU has ensured that this machine is suitable for use under the standard operating conditions defined in this operator's manual, with a **STATIC TEST COEFFICIENT OF 1.25** and a **DYNAMIC TEST COEFFICIENT OF 1**, as specified in harmonized standard **EN 1459** for variable reach machines.
- Before commissioning, the facility manager must make sure that the machine is appropriate for the work to be done, and perform certain tests (in accordance with applicable legislation).

#### B - ADAPTING THE MACHINE TO USUAL ENVIRONMENTAL CONDITIONS

- Our machines are designed to be used within a temperature range of -18 °C (-0.4°F) to +43 °C (109.4°F).
- In addition to the standard equipment fitted on your machine, many options are available, such as: road lighting, stop lights, rotating beacon light, reverse lights, front worklight, rear worklight, boom head worklight, etc. (depending on machine model).
- The operator must take into account the operating conditions to specify the machine's signaling and lighting equipment. Consult your dealer.
- Take into account the climatic and atmospheric conditions of the operation site.
  - Protection against frost (↖ 3 - MAINTENANCE: LUBRICANTS AND FUEL).
  - Adaptation of lubricants (ask your dealer for information).
  - Engine filtration (↖ 3 - MAINTENANCE: FILTER CARTRIDGES AND BELTS).

#### **⚠ IMPORTANT ⚠**

*For operation under average climatic conditions, i.e. between -15 °C and +35 °C, correct levels of lubricants in all the circuits are checked in production. -15 °C to +35 °C*

*For operation under more severe climatic conditions, before starting up, drain all circuits then fill using lubricants suitable for the ambient temperatures.*

*The same applies to the coolant.*

- Take into account the fire risk associated with use in dusty and flammable conditions (e.g. straw, flour, sawdust, organic waste, etc.).
- MANITOU recommends fitting your machine with an individual fire extinguisher to neutralize any fire as soon as it starts. Solutions exist, consult your dealer.

#### **⚠ IMPORTANT ⚠**

*Your machine is designed for outdoor use under normal atmospheric conditions and indoor use in suitably aerated and ventilated premises. For use in very dusty atmospheres (flour, sawdust), solutions are available. Consult your dealer.*

*It is prohibited to use the machine in areas where there is a risk of fire or which are potentially explosive (e.g. refineries, fuel or gas depots, stores of inflammable products, etc.).*

*Special equipment is available for use in such areas (ask your dealer for information).*

Our machines comply with Directive 2014/30/EU (2015/208/EU for our type-approved "TRACTOR" machines) concerning electromagnetic compatibility (EMC), and with the corresponding harmonized standard EN 12895. Their correct operation is no longer guaranteed if they are used within areas in which the electromagnetic fields exceed the limit specified by this standard (20 V/m).

**⚠ IMPORTANT ⚠**

*After commissioning, any machine equipped with devices that are likely to emit non-ionizing radiation (e.g. radio transmitter, radiofrequency ID reader, data collection system, etc.) can cause injury, especially to people with active or inactive medical devices or implants.*

- Directive 2002/44/EC requires company managers to not expose their employees to excessive vibration doses. There is no recognized code of measurement for comparing the machines of different manufacturers. The actual doses received cannot therefore be measured under actual operating conditions at the user's premises.
- The following are some tips for minimizing these vibration doses:
  - Select the most suitable machine and attachment for the intended use.
  - Adapt the seat adjustment to the operator's weight (depending on machine model) and maintain it in good condition, as well as the cab suspensions. Inflate the tires in accordance with recommendations.
  - The seat is an essential way of reducing the vibrations transmitted to the operator. In the event of seat replacement, please contact MANITOU.
  - Ensure that the operators adapt their operating speed to suit the conditions on site.
  - As far as possible, arrange the site in such a way as to provide a flat running surface and remove obstacles and harmful potholes.

### C - MODIFYING THE MACHINE

- For your safety and that of others, you must not change the structure and settings of the various components of your machine (hydraulic pressure, calibrating limiters, engine speed, addition of extra equipment, addition of counterweight, unapproved attachments, alarm systems, etc.) yourself. In this case, the manufacturer cannot be held responsible.

### D - FRENCH ROAD TRAFFIC RULES

*(or see current legislation in other countries)*

- Only one EC declaration of conformity is issued. It must be kept in a safe place.
- The road traffic rules for the machines are subject to the provisions of the highway code, according to the following categories:
  - Construction machinery (MT range): public works vehicle not predominantly for use on roads (point 6.9 of Article R.311-1 of the French Highway Code). The machine must have a 25 disc displayed on the rear of the machine and an operating license plate.
  - Non-type-approved "Tractor" machinery for agricultural work: (point 6.2 of Article R.311-1 of the French Highway Code). The machine must be fitted with an operating license plate.
  - Type-approved "Tractor" machinery for agricultural work: Agricultural tractor type T1a (point 5.1.1 of Article R.311-1 of the French Highway Code). The machine must be licensed.

### SPECIAL INSTRUCTIONS APPLICABLE TO TYPE-APPROVED "TRACTOR" MACHINES

- All approved machines are supplied with a "Tractor" certificate of compliance with Regulation 167/2013, to be retained by the owner, and a page of administrative details together with a CNIT number (national type approval code) for registration at the prefecture.
- The owner of the machine is responsible for carrying out the necessary procedures for obtaining the vehicle registration document within the time limit defined by the regulations.
- The operator must hold a category B driver's license, unless granted an exemption.
- The machine must be driven on the public highway in accordance with the instructions given in the manual supplied with the machine (Gross weight, Gross combination weight, towing load, axle loads, maximum speeds, etc. according to the type/version). The operator must be in possession of the machine's registration document.

**⚠ IMPORTANT ⚠**

*When towing a trailer or agricultural equipment, the traveling speed of the machine is limited to 25 km/h.  
In this case, a "25" disc must be affixed to the rear of the convoy.*

### E - MACHINE CAB PROTECTION

- All machines comply with standard ISO 3471 Roll-over Protective Structures (ROPS)
- All machines comply with standard ISO 3449 Falling-Object Protective Structures (FOPS) (Level I or II) (← 2 - DESCRIPTION OF STICKERS AND PLATES)
- The windows used on our machines comply with standard ECE-R43 Operator Protective Structures (OPS).
- Approved "TRACTOR" machines also comply with the regulations:
  - (appendix 1322/2014-OCDE Code 4).
  - (appendix 1322/2014-OCDE Code 10).

**⚠ IMPORTANT ⚠**

*Structural damage or overturning, a modification, changes or a poorly executed repair can reduce the protective efficiency of the cab, canceling its compliance.  
Do not perform welding or drilling on the cab structure.  
Consult your dealer to determine the limits of this structure without canceling its compliance.*

## **INSTRUCTIONS**

---

- The operator's manual must always be in good condition and kept in the place provided in the machine and in the language used by the operator.
- The operator's manual and any plates or stickers which are no longer legible or are damaged, must be replaced immediately.

## **MAINTENANCE**

---

- Maintenance or repairs other than those detailed in Part: 3 - MAINTENANCE must be carried out by qualified personnel (consult your dealer) and in the necessary safety conditions to preserve the health of the operator and any third party.

**⚠ IMPORTANT ⚠**

*Your machine must be periodically inspected to ensure its continued compliance.*

*The frequency of this inspection is defined by the current legislation in force in the country in which the machine is used.*

- Example for France "The manager in charge of the establishment using a machine must open and maintain a maintenance log for each machine (order of March 2, 2004) and undergo a general periodic inspection every 6 months (order of March 1, 2004)".



# INSTRUCTIONS FOR THE OPERATOR

## FOREWORD

### ⚠ IMPORTANT ⚠

*The risk of accident while using, servicing or repairing your machine can be reduced if you follow the safety instructions and preventive measures detailed in this manual. Failure to respect the safety and operating instructions, or the instructions for repairing or servicing your machine may lead to serious, even fatal accidents.*

- Only the operations and maneuvers described in these operator's manual must be performed. The manufacturer cannot predict all possible risky situations. Consequently, the safety instructions given in the operator's manual and on the machine itself are not exhaustive.
- At all times, as an operator, you must envisage, within reason, the possible risk to yourself, to others or to the machine when you use it.
- The operator is responsible for the machine in all circumstances, regardless of whether he is present in the driver's cab.

### ⚠ IMPORTANT ⚠

*In order to reduce or prevent any danger with a MANITOU-approved attachment, follow the instructions in paragraph: 4 - ADAPTABLE ATTACHMENTS AVAILABLE ON THE RANGE: INTRODUCTION.*

## GENERAL INSTRUCTIONS

### A – OPERATOR'S MANUAL

- Read the operator's manual carefully.
- The operator's manual must always be in good condition and in the place provided for it on the machine.
- You must report any plates and stickers which are no longer legible or which are damaged.

### B - AUTHORIZATION FOR USE IN FRANCE

*(or see current legislation in other countries).*

- Only qualified, authorized personnel can use the machine. This authorization is given in writing by the appropriate person in the establishment where the machine is to be used and must be carried permanently by the operator.
- The operator is not empowered to authorize the driving of the machine by another person.

### C - MAINTENANCE

- If the operator sees that the machine is not in good working order or does not comply with the safety instructions, he must inform his manager of this immediately.
- The operator is prohibited from carrying out any repairs or adjustments himself, unless he has been trained for this purpose. He must keep the machine properly cleaned if this is his responsibility.
- The operator is responsible for carrying out daily maintenance (↩ 3 - MAINTENANCE).
- The operator is responsible for deciding and adjusting the frequency and type of the cleaning needed to prevent the risk of fire ensuing from the build-up of flammable material(s). The operator should pay special attention to all the areas of the machine where these high-risk materials are likely to accumulate (e.g. engine compartment, under the boom, above the axles, etc.).

### D - TIRES

- The operator must ensure tires are suitable for the nature of the ground (see contact surface with the ground for the tires in the chapter: 2 - DESCRIPTION: TIRES). Optional solutions are available, please consult your dealer.
  - SAND tires.
  - FARM tires.
  - Snow chains.
- The machine's four tires must be the same brand, the same dimensions, the same structure (radial or diagonal) and the same usage category (normal, snow or special), and must have the same degree of tread wear.
- In the event of tire replacement, use tires authorized by MANITOU that are the same type and dimensions. Using different tires voids the machine's type approval and you may be liable.
- If you are replacing just one of the machine's tires (e.g. because it is damaged), we recommend choosing a tire with the same degree of wear as the remaining tires so as not the damage the transmission's kinematic chain.

### ⚠ IMPORTANT ⚠

*Do not use the machine if the tires are damaged or excessively worn, because this could put your own safety or that of others at risk, or cause damage to the machine itself. The fitting of foam inflated tires is prohibited and is not guaranteed by the manufacturer unless with prior authorization.*

**E - MODIFYING THE MACHINE**

- For your safety and that of others, you must not change the structure and settings of the various components of the machine (hydraulic pressure, calibrating limiters, engine speed, addition of extra equipment, addition of counterweight, unapproved attachments, alarm systems, etc.) yourself. In this event, the manufacturer cannot be held responsible.

**F - LIFTING PEOPLE**

- The use of working equipment and load lifting attachments to lift people is:
  - either forbidden
  - or authorized exceptionally and under certain conditions (< regulations in force in the country in which the machine is used).
- The pictogram posted at the operator station reminds you that:
  - Left-hand column
    - It is forbidden to lift people, with any kind of attachment, using a non PLATFORM-fitted machine.
  - Right-hand column
    - With a PLATFORM-fitted machine, people can only be lifted using platforms designed by MANITOU for this purpose.
- MANITOU sells equipment specifically designed for lifting people (OPTION PLATFORM-fitted machine; contact your dealer).

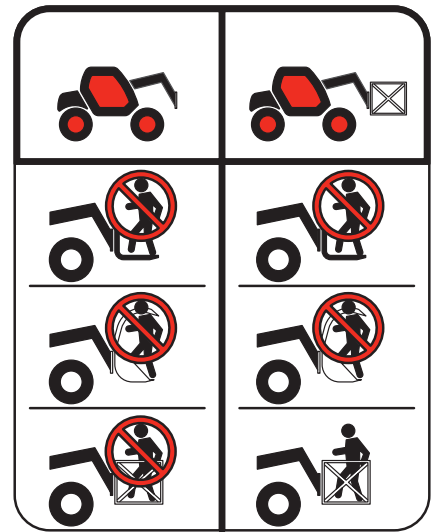

**A - BEFORE STARTING UP THE MACHINE**

- Perform the daily maintenance operations (< 3 - MAINTENANCE).
- Make sure that the driver's cab is clean, particularly the floor and floor mat. Check that no movable object may hinder the operation of the machine.
- Make sure the lights, turn signals and windshield wipers are working properly.
- Make sure the rear-view mirrors are in good condition, clean and properly adjusted.
- Make sure the horn works.

**B - AVAILABLE IN THE DRIVER'S CAB**

- Whatever his experience, the operator is advised to familiarize himself with the position and operation of all the controls and instruments before operating the machine.
- Wear clothes suitable for driving the machine, avoid loose clothing.
- Make sure you have the appropriate protective equipment for the task to be performed.
- Prolonged exposure to high noise levels may cause hearing problems. It is recommended to wear ear muffs to protect against excessive noise.
- Always face the driver's cab access when getting in and out of the lift truck and use the handle(s) provided for this purpose. Do not jump out of the machine.
- Remain alert at all times when using the machine. Do not listen to the radio or music using headphones or earphones.
- Never operate the lift truck when hands or feet are wet or soiled with greasy substances.
- For increased comfort, adjust the seat to your requirements and adopt the correct position in the driver's cab.

**⚠ IMPORTANT ⚠**

*Under no circumstances must the seat be adjusted while the machine is moving.*

- The operator must always be in his normal position in the driver's cab: Arms and legs, and generally any part of the body, should be kept inside the driver's cab of the machine.
- The safety belt must be worn and adjusted to the operator's size.
- The control units must never be used for any other than their intended purposes (e.g. Climbing onto or down from the machine, coat hanger, etc.).
- If the control components are fitted with a forced operation (lever lock) device, it is forbidden to leave the cab without first putting these controls in neutral.
- It is prohibited to carry passengers either on the machine or in the cab.

**C - ENVIRONMENT**

- Comply with site safety regulations.
- If you have to use the machine in a dark area or work at night, make sure it is equipped with work lights.
- During handling operations, make sure that no one is in the way of the machine and its load.
- Do not allow anybody to come near the working area of the machine or pass beneath an elevated load.
- The maximum slope on which the machine can be used in relation to the capacity of the service brake is 20%.
- When using the lift truck on a transverse slope, before lifting the boom observe the instructions given in the paragraph: INSTRUCTIONS FOR HANDLING A LOAD: D - TRANSVERSE ATTITUDE OF THE MACHINE.
- Traveling on a longitudinal slope:
  - Drive and brake gently.

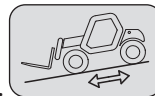

- Moving without load: Forks or attachment facing downhill.

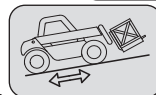

- Moving with load: Forks or attachment facing uphill.

- Take into account the machine's dimensions and its load before trying to negotiate a narrow or low passageway.
- Never move onto a load bridge without having first checked:
  - That it is suitably positioned and made fast.
  - That the unit to which it is connected (wagon, truck, etc.) will not shift.
  - That this bridge is prescribed for the total weight of the machine, laden or unladen.
  - That this bridge is prescribed for the size of the machine.
- Never move onto a foot bridge, floor or freight lift, without being certain that they are suitable for the weight and size of the machine, laden or otherwise, and without having checked that they are in sound working order.
- Be careful in the area of loading bays, trenches, scaffolding, soft ground and manholes.

- Make sure the ground is stable and firm under the wheels and/or stabilizers before lifting or removing the load. If necessary, add appropriate wedging under the stabilizers.
- Make sure that the scaffolding, loading platform, pilings or ground is capable of bearing the load.
- Never stack loads on uneven ground, they may tip over.

**⚠ IMPORTANT ⚠**

*If the load or the attachment must remain above a structure for a prolonged period of time, there is the risk that it will bear on the structure as the jib descends due to cooling of the oil in the cylinders.*

*To eliminate this risk:*

- *Regularly check the distance between the load or the attachment and the structure and readjust this if necessary.*
- *If possible use the machine at an oil temperature as close as possible to ambient temperature.*

- In the case of work near to overhead lines, ensure that the safety distance is sufficient between the machine's working area and the overhead line.

**⚠ IMPORTANT ⚠**

*Do not operate this machine during thunderstorms, snowstorms, periods of frost, or in hazardous weather conditions.*

**⚠ IMPORTANT ⚠**

*You must consult your local electrical supplier.*

*You could be electrocuted or seriously injured if you operate or park the machine too close to power lines.*

*In the event of high winds, do not carry out handling work that jeopardizes the stability of the machine and its load, particularly if the load catches the wind badly.*

- Prevent the fire risk associated with use in dusty and flammable conditions (e.g. straw, flour, sawdust, organic waste, etc.).

## **D - VISIBILITY**

- The safety of people within the machine's working area, as well as that of the machine itself and the operator, are dependent on good operator visibility of the machine's immediate surroundings in all situations and at all times.
- This machine has been designed to allow good operator visibility (direct or indirect by means of rear-view mirrors) of the immediate surroundings of the machine while driving with no load and with the boom in the transport position.
- Special precautions must be taken if the size of the load restricts visibility towards the front:
  - moving in reverse,
  - site layout,
  - assisted by a person directing the operation (while standing outside the machine's area of travel), making sure to keep this person clearly in view at all times,
  - in any case, avoid reversing over long distances.
- Certain special accessories may require the machine to travel with the boom in the raised position. In such cases, visibility on the right hand side is restricted, and special precautions must be taken:
  - site layout,
  - assisted by a person directing the operation (while standing outside the machine's area of travel).
  - replacement of a suspended load by a load on a pallet.
- If visibility of your road is inadequate, ask someone to assist by directing the operation (while standing outside the machine's area of travel), making sure to keep this person clearly in view at all times.
- Keep all components affecting visibility in a clean, properly adjusted state and in good working order (e.g. windshields, windows, windshield wipers, windshield washers, driving lights and worklights, rear-view mirrors).

## E - STARTING THE MACHINE

### SAFETY INSTRUCTIONS

#### **⚠ IMPORTANT ⚠**

*The machine must only be started up or maneuvered when the operator is sitting in the driver's cab with seat belt fastened and adjusted.*

- Never try to start the machine by pushing or towing it. Such an operation may cause severe damage to the transmission. If necessary, towing requires the transmission to be put in neutral (< 3 - MAINTENANCE).
- If using an emergency battery for start-up, use a battery with the same characteristics and respect battery polarity when connecting it. Connect at first the positive terminals before the negative terminals.

#### **⚠ IMPORTANT ⚠**

*Failure to respect polarity between batteries can cause serious damage to the electrical circuit.  
The electrolyte in the battery may produce an explosive gas. Avoid flames and generation of sparks close to the batteries.  
Never disconnect a battery while it is in charge.*

### INSTRUCTIONS

- Check the closing and locking of the hood(s).
- Check that the cab door is closed.
- Firmly press the brake pedal and hold in position and hold it down.
- Turn the ignition key to position (I) to switch on the machine and the engine preheat system.
- Check that the forward/reverse selector is in neutral, and that the manual parking brake is on.
- Check the fuel level on the dashboard gauge.
- Check the DEF (diesel exhaust fluid) level on the dashboard gauge. (depending on machine model)
- Turn the ignition key to position (III) for no longer than 15 seconds. The engine should then start. Release the ignition key and let the engine run at idling speed.
- Preheat the engine between each start attempt.
- Make sure all the signal lights on the control instrument panel are off.
- Do not use a machine that is non-compliant.
- Check all control instruments when the engine is warm and at regular intervals during use, so as to quickly detect any faults and to be able to correct them without any delay.
- If an instrument does not show the correct display, stop the engine and immediately carry out the necessary operations.

## F - OPERATING THE MACHINE

### SAFETY INSTRUCTIONS

#### **⚠ IMPORTANT ⚠**

*We would like to draw the operators' attention to the risks involved in using the machine, in particular:*

*- Risk of losing control.*

*- Risk of loss of lateral and frontal stability of the machine.*

*The operator must remain in control of the machine.*

*In the event of the machine overturning, do not try to leave the cab during the incident.*

***YOUR BEST PROTECTION IS TO STAY FASTENED IN THE CAB.***

- Observe the company's traffic regulations or, by default, the public highway code.
- Do not carry out operations which exceed the capacities of your machine or attachment.
- Always drive the machine with the forks or attachment in the transport position, i.e., 300 mm (11.81 in) from the ground, the boom retracted and the forks carriage sloping backwards.
- Only carry loads which are balanced and properly anchored to avoid any risk of a load falling off.
- Ensure that pallets, cases, etc. are in good order and suitable for the load to be lifted.
- Familiarize yourself with the machine on the terrain where it will be used.
- Ensure that the service brakes are working properly.
- The loaded machine must not travel at speeds in excess of 12 km/h (7.46 mph).
- Drive smoothly at an appropriate speed for the operating conditions (land configuration, load on the machine).
- Do not use the hydraulic boom controls when the machine is moving.
- Never change the steering mode whilst driving.
- Ensure that visibility is adequate.
- Do not maneuver the machine with the boom in the raised position unless under exceptional circumstances and then with extreme caution, at very low speed and using gentle braking.
- Take bends slowly.

- In all circumstances make sure you are in control of your speed.
- On damp, slippery or uneven terrain, drive slowly.
- Brake gently, never abruptly.
- Only use the machine's forward/reverse selector from a stationary position and never do so abruptly.
- Do not drive with your foot on the brake pedal.
- Always remember that hydrostatic type steering is extremely sensitive to movement of the steering wheel, so turn it gently and not jerkily.
- Never leave the engine on when the lift truck is unattended.
- Do not leave the cab when the machine has a raised load.
- Look where you are going and always make sure you have good visibility along the route.
- Use the rear-view mirrors frequently.
- Drive around obstacles.
- Never drive on the edge of a ditch or steep slope.
- It is dangerous to use two machines simultaneously to handle heavy or bulky loads, since this operation requires particular precautions to be taken. It must only be used exceptionally and after risk analysis.
- The ignition switch has an emergency stop mechanism in case of an operating anomaly occurring in the case of machines not fitted with a punch-operated cut-out.

## INSTRUCTIONS

- Always drive the machine with the forks or attachment in the transport position, i.e., 300 mm (11.81 in) from the ground, the boom retracted and the forks carriage sloping backwards.
- For machines with gearboxes, use the recommended gear (↩ 2 - DESCRIPTION: INSTRUMENTS AND CONTROLS).
- Select the steering mode appropriate for the use and/or working conditions (↩ 2 - DESCRIPTION: INSTRUMENTS AND CONTROLS) (depending on machine model).
- Deactivate the parking brake.
- Shift the forward/reverse selector to the selected direction of travel and accelerate gradually until the machine moves off.

### **⚠ IMPORTANT ⚠**

*Starting and moving the machine on a slope may be a real hazard.*

*If the machine is parked or stopped, adhere scrupulously to the following instructions for moving it:*

*- Press the service brake pedal.*

*- Release the parking brake.*

*- Engage the appropriate gear. (depending on machine model)*

*- Select forward or reverse direction.*

*- Ensure that there is no one or anything impeding the movement of the machine.*

*- Release the service brake pedal and accelerate the engine.*

*The use of the machine loaded or with a trailer increases the risk. In this case, remain extremely vigilant.*

*Each braking system operates independently.*

*In the event of an emergency, use the service brake and/or manual parking brake to immobilize the machine.*

*With the engine off, release the manual parking brake only after restarting the engine and making sure that the service brake is functional.*

## G - STOPPING THE MACHINE

### SAFETY INSTRUCTIONS

- Never leave the ignition key in the machine during the operator's absence.
- When the machine is stationary, or if the operator has to leave his cab (even for a moment), place the forks or attachment on the ground, apply the parking brake and place the forward/reverse selector in neutral.
- Make sure that the machine is not stopped in any position that will interfere with the traffic flow and at less than one meter from the track of a railway.
- In the event of prolonged parking on a site, protect the machine from bad weather, particularly from frost (check the level of antifreeze), and close and lock all the machine accesses (doors, windows, cowls, etc.).

### INSTRUCTIONS

- Preferably place the lift truck on flat ground.
- Set the forward/reverse selector to neutral. If parking on a slope, position the lift truck perpendicular to the slope. The slope must be less than 15%.
- Apply the parking brake. Make sure the lift truck has come to a complete standstill before getting out of the driver's cab.
- Fully retract the jib.
- Lower the forks or attachment to rest on the ground.
- When using an attachment with a grab or jaws, or a bucket with hydraulic opening, close the attachment fully.
- Before stopping the machine after intensive work, leave the engine idling for a few moments to allow the coolant and oil to lower the temperature of the engine and transmission. Do not forget this precaution, in the event of frequent stops or warm stalling of the engine, or else the temperature of certain parts will rise significantly due to the stopping of the cooling system, with the risk of badly damaging such parts.
- Stop the engine with the ignition switch and remove the key.
- Lock all the openings to the machine (doors, windows, cowls, etc.).
- Turn the battery cut-off to the "OFF" position in accordance with the recommendations (↩ 2 - DESCRIPTION)

## H - DRIVING THE MACHINE ON THE PUBLIC HIGHWAY

(or see current legislation in other countries)

### FRENCH ROAD TRAFFIC RULES

- The driving of non-type-approved "Tractor" machines on the public highway is subject to the provisions of the French Highway Code relating to special machines, defined in Article R.311-1 of the French Highway Code, in category B of the Equipment Order of November 20, 1969, which determines the procedures applicable to special machines. The machine must be fitted with an operating license plate.
- The driving of type-approved "Tractor" machines on the public highway is subject to the provisions of the French Highway Code relating to agricultural tractors, defined in Article R.311-1 of the French Highway Code. The machine must be licensed.
- The machine must be driven on the public highway in accordance with the instructions given in the manual supplied with the machine (Gross weight, Gross combination weight, towing load, axle loads, maximum speeds, etc. according to the type/version). The operator must be in possession of the machine's registration document.
- The operator must hold an HGV license, unless granted an exemption.
- When towing a trailer or agricultural equipment, the travel speed of the machine is limited to 25 km/h. In this case, a "25" disc must be affixed to the rear of the convoy.

### GERMAN ROAD TRAFFIC RULES

#### **⚠ IMPORTANT ⚠**

*For machines with the "Allgemeine Betriebserlaubnis" (general operating permit or ABE, in accordance with Article 20 of the StVZO "Straßenverkehrs-Zulassungsordnung"), follow the instructions below:*

- Disconnect the reversing sound alarm before using a machine with a general operating permit (ABE) on the public highway.

#### **⚠ IMPORTANT ⚠**

*Always reconnect the sound alarm before handling on private roads.*

- Before you use the machine for handling operations on private roads:
  - Make sure that the machine's reversing sound alarm is connected and working properly.
  - Perform a functional test by putting the machine into reverse gear.
  - The audible alarm sounds.
  - Do not use the machine if the audible alarm is not working. Check the audible alarm's connection and repeat the test. Consult your dealer if the problem persists.

### SAFETY INSTRUCTIONS

- Operators driving on the public highway must comply with current highway code legislation.
- The machine must comply with current road legislation. If necessary, there are optional solutions. Contact your dealer.

### INSTRUCTIONS

- Make sure the revolving light is in place, switch it on and verify its operation.
- Make sure the lights, turn signals and windshield wipers are working properly.
- Check the cleanliness of the machine's mudguards.
- Check the general cleanliness of the machine before driving on public roads.
- Switch off the worklights if the machine is fitted with them.
- Select the steering mode "HIGHWAY TRAFFIC" (↩ 2 - DESCRIPTION: INSTRUMENTS AND CONTROLS) (depending on machine model).
- Fully retract the jib and set the attachment approximately 300 mm (11.81 in) off the ground.
- Put the frame leveling in the central position, i.e., the transverse axis of the axles parallel to the frame (depending on the machine model).
- Fully raise the stabilizers and turn the shoes inwards (depending on the machine model).

#### **⚠ IMPORTANT ⚠**

*Never coast in neutral (forward/reverse selector or gear lever in neutral or transmission cut-off button pressed) to preserve the machine's engine brake. Failure to observe this instruction on a slope will lead to excessive speed, which may make the machine uncontrollable (steering, brakes) and cause serious mechanical damage.*

#### DRIVING THE MACHINE WITH A FRONT-MOUNTED ATTACHMENT

- You must comply with current regulations in your country, covering the possibility of driving on the public highway with a front-mounted attachment on your machine.
- If road legislation in your country authorizes circulation with a front-mounted attachment, you must at least:
  - Protect and report any sharp and/or dangerous edges on the attachment (◀ 4 - ADAPTABLE ATTACHMENTS AVAILABLE ON THE RANGE).
  - The attachment must not be loaded.
  - Make sure that the attachment does not mask the lighting range of the forward lights.
  - Make sure that current legislation in your country does not require other obligations.

#### OPERATING THE MACHINE WITH A TRAILER

- For using a trailer, observe the regulations in force in your country (maximum travel speed, braking, maximum weight of trailer, etc.).
- Do not forget to connect the trailer's electrical equipment to that of the machine.
- The trailer's braking system must comply with current legislation.
- If pulling a trailer with assisted braking, the tractor machine must be equipped with a trailer braking mechanism. In this case, do not forget to connect the trailer braking equipment to that of the machine.
- The vertical force on the towing hook must not exceed the maximum authorized by the manufacturer (consult the manufacturer's plate on your machine).
- The authorized gross vehicle weight must not exceed the maximum weight authorized by the manufacturer (◀ 2 - DESCRIPTION: SPECIFICATIONS).

**IF NECESSARY, CONSULT YOUR DEALER.**



## INSTRUCTIONS FOR HANDLING A LOAD

### A - CHOICE OF ATTACHMENTS

- Only attachments approved and authorized by MANITOU can be used on its machines.
- Make sure the attachment is suitable for the work to be done (◀ 4 - ADAPTABLE ATTACHMENTS AS OPTIONS ON THE RANGE).
- If the machine is equipped with the single sideshift attachment OPTION (TSDL), use only the authorized attachments (◀ 4 - ADAPTABLE ATTACHMENTS AS OPTIONS ON THE RANGE).
- Make sure the attachment is correctly installed and locked onto the machine carriage.
- Make sure that your machine attachments are working properly.
- Comply with the load chart limits for the machine for the attachment used.
- Do not exceed the rated capacity of the attachment.
- Never lift a slung load without the attachment provided for the purpose, as there is a risk of the sling slipping (◀ INSTRUCTIONS FOR HANDLING A LOAD: H - PICKING UP AND PUTTING DOWN A SUSPENDED LOAD).
- Do not handle loads suspended by straps directly on the forks (e.g.:big bags), as there is a risk of shearing on sharp edges. Use an attachment designed for this purpose.

### B - WEIGHT OF LOAD AND CENTER OF GRAVITY

- Before picking up a load, you must know its weight and its center of gravity.
- The longitudinal position of the center of gravity in relation to the heel of the forks (Fig. B1) is defined on the load chart for your machine (◀ 2 - DESCRIPTION: DIMENSIONS AND LOAD CHARTS). For loads with center of gravity exceeding this distance, contact your dealer.
- For irregular loads, determine the transverse center of gravity before any handling (fig. B2) and set it in the longitudinal axis of the machine.

#### ⚠ IMPORTANT ⚠

*It is forbidden to handle a load heavier than the effective capacity defined on the machine load chart.  
For loads with a moving center of gravity (e.g. liquids), take account of the variations in the center of gravity in order to determine the load to be handled and be extra vigilant and careful to limit these variations as far as possible.*

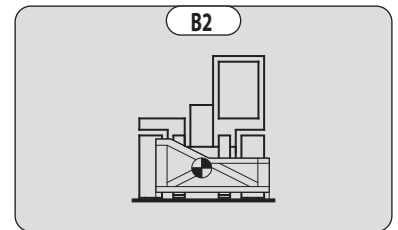
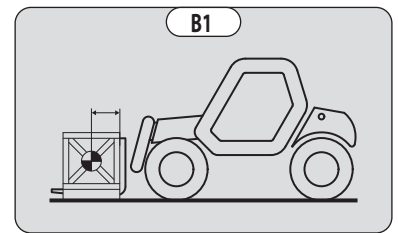

### C - LONGITUDINAL STABILITY INDICATOR

#### ⚠ IMPORTANT ⚠

*Always watch this device during handling operations.*

- Letters and angle indicator (fig. C1) allow to read and respect load capacities of the lifttruck according to the load chart (◀ 2 - DESCRIPTION: LOAD CHART).
- When the device is in limit stability, it is forbidden to perform so-called «AGGRAVATING» movements, these being:
  - Extending the boom.
  - Lowering the boom.
- Perform movements to relieve aggravation in the following order (fig. C2): if necessary, raise the boom (1), retract the boom as far as possible (2) and lower the boom (3) to release the load.

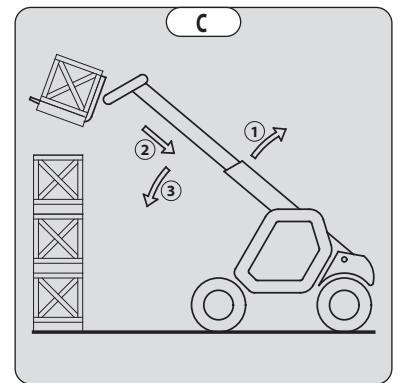

## D - TRANSVERSE ATTITUDE OF THE MACHINE

Depending on machine model

The transverse attitude is the transverse slope of the frame with respect to the horizontal. Raising the boom reduces the machine's lateral stability. The machine's transverse attitude must be set with the boom in the down position as follows:

### 1 - MACHINE WITHOUT FRAME LEVELING USED ON TIRES

- Position the machine so that the bubble in the level is between the two lines (↖ 2 - DESCRIPTION: INSTRUMENTS AND CONTROLS).

### 2 - MACHINE WITH FRAME LEVELING USED ON TIRES

- Correct the tilt using the hydraulic control and check the horizontality with the spirit level. The bubble of the level must be between the two lines (↖ 2 - DESCRIPTION: INSTRUMENTS AND CONTROLS).

### 3 - MACHINE USED ON STABILIZERS

- Set the two stabilizers on the ground and raise the two front wheels of the machine (fig. D1).
- Correct the tilt using the stabilizers (Fig. D2) and check the horizontality with the spirit level. The bubble of the level must be between the two lines (↖ 2 - DESCRIPTION: INSTRUMENTS AND CONTROLS). In this position, the two front wheels must be off the ground.

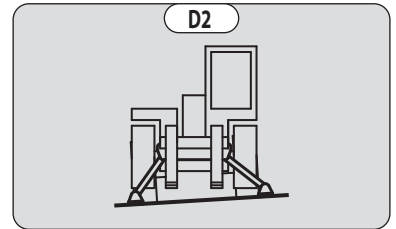
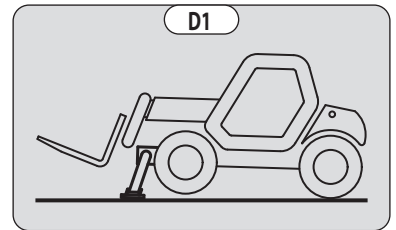

## E - PICKING UP A LOAD ON THE GROUND

- Approach the machine perpendicular to the load, with the boom retracted and the forks in a horizontal position (fig. E1).
- Adjust the fork spacing and centering relative to the load to ensure stability (Fig. E2) (optional solutions exist, consult your dealer).
- Never lift a load with a single fork.

### ⚠ IMPORTANT ⚠

*Beware of the risks of trapping or squashing limbs when manually adjusting the forks.*

- Move the machine forward slowly (1) and bring the forks up to the stop in front of the load (Fig. E3). If necessary, slightly lift the boom (2) while picking up the load.
- Bring the load into the transport position.
- Tilt the load far enough backward to ensure stability (loss of load on braking or going downhill).

### FOR A NON-PALLETIZED LOAD

- Tilt the carriage (1) forwards and move the machine slowly forwards (2), to insert the fork under the load (Fig. E4) (chock the load if necessary).
- Continue to move the machine (2) forward, tilting the carriage (3) (fig. E4) backward to position the load on the forks and check the load's longitudinal and lateral stability.

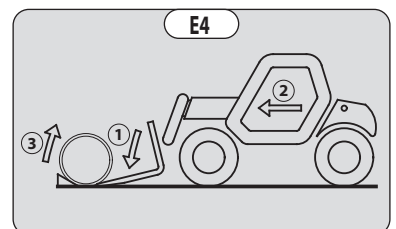
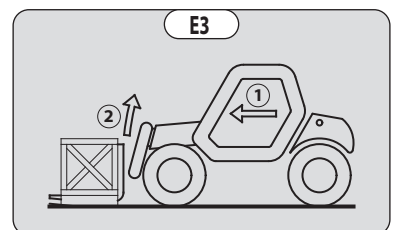
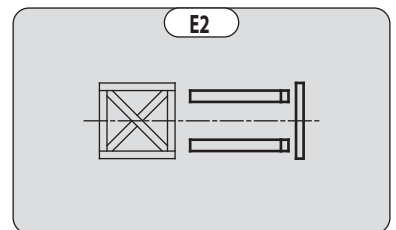
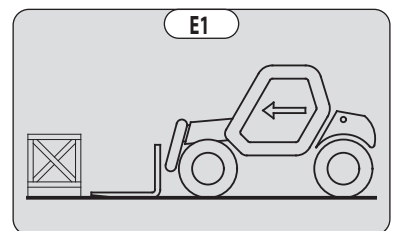

## F - PICKING UP AND PUTTING DOWN A HIGH LOAD ON TIRES

### ⚠ IMPORTANT ⚠

*You must not raise the boom if you have not checked the transverse attitude of the machine (← INSTRUCTIONS FOR HANDLING A LOAD D - TRANSVERSE ATTITUDE OF THE MACHINE).*

REMINDER: Make sure that the following operations can be performed with good visibility (← OPERATING INSTRUCTIONS UNLADEN AND LADEN: D - VISIBILITY).

### PICKING UP A HIGH LOAD ON TIRES

- Ensure that the forks will easily pass under the load.
- Raise and extend the boom (1) (2) until the forks are at the level of the load. If necessary, move the machine (3) forward (fig. F1), driving very slowly and carefully.
- Always remember to keep the distance necessary for inserting the forks under the load, between the stack and the machine (fig. F1) and use the shortest possible length of boom.
- Insert the forks under the load as far as they will go by alternately extending and lowering the boom (1) or, if necessary, moving the machine forward (2) (fig. F2). Activate the parking brake and place the forward/reverse selector in neutral.
- Lift the load slightly (1) and tilt the carriage (2) backwards to stabilize the load (Fig. F3).
- Tilt the load sufficiently backward to ensure its stability.
- Monitor the longitudinal stability indicator (← INSTRUCTIONS FOR HANDLING A LOAD: C - LONGITUDINAL STABILITY INDICATOR). If it is overloaded, set the load back down in the place from which it was picked up.
- If possible, lower the load without moving the machine. Raise the boom (1) to release the load, retract (2) and lower the jib (3) to set the load into transport position (fig. F4).
- If this is not possible, reverse the machine (1), maneuvering very gently and carefully to release the load. Retract (2) and lower the boom (3) to bring the load into the transport position (fig. F5).

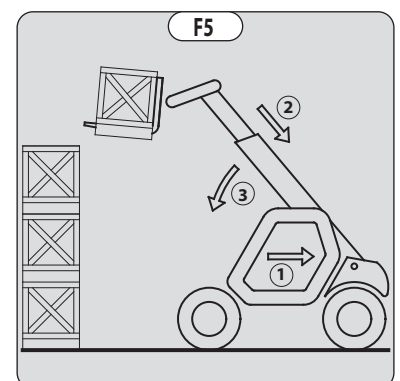
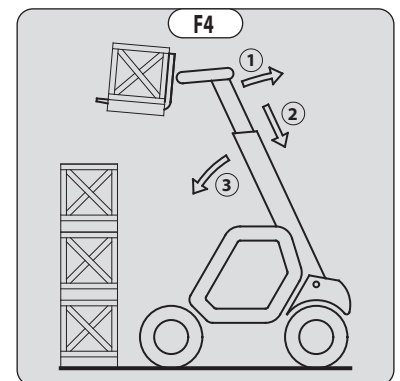
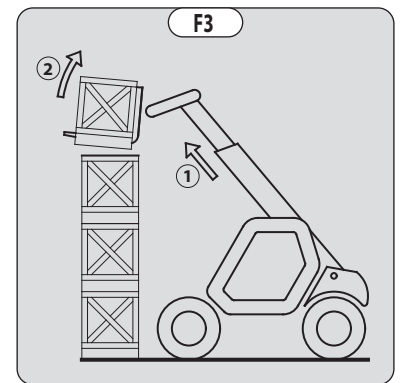
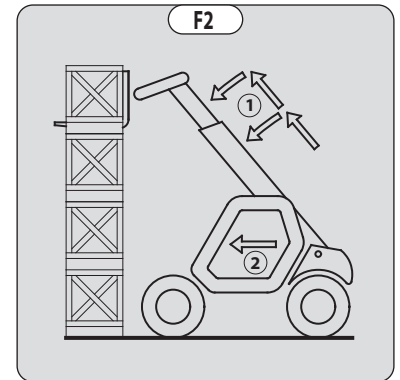
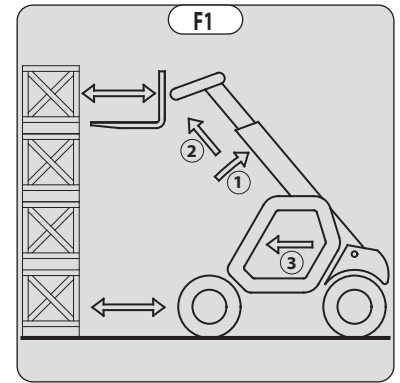

## PUTTING DOWN A HIGH LOAD ON TIRES

- Approach the load in the transport position in front of the stack (Fig. F6).
- Activate the parking brake and place the forward/reverse selector in neutral.
- Raise and extend the boom (1) (2) until the load is above the stack, while monitoring the longitudinal stability indicator (☞ INSTRUCTIONS FOR HANDLING A LOAD: C - LONGITUDINAL STABILITY INDICATOR). If necessary, move the lift truck (3) forward (fig. F7), driving very slowly and carefully.
- Place the load in a horizontal position and put it down on the pile by lowering and retracting the boom (1) (2) in order to position the load correctly (Fig. F8).
- If possible, release the forks by alternately retracting and raising the boom (1) (Fig. F9). Then set the forks into transport position.
- If this is not possible, reverse the machine (1), maneuvering very slowly and carefully to release the forks (fig. F10). Then set the forks into transport position.

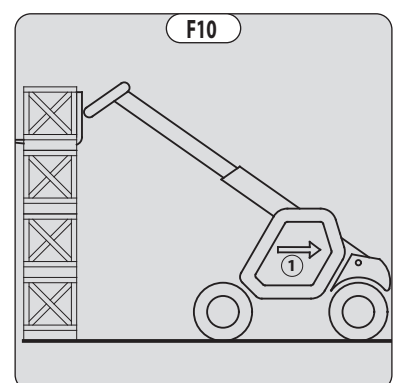
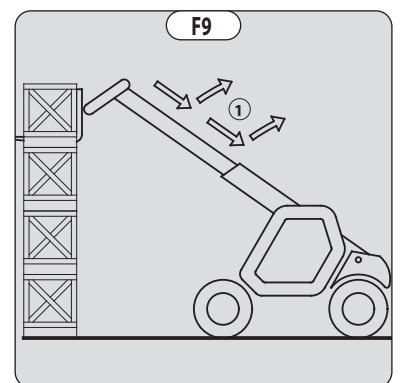
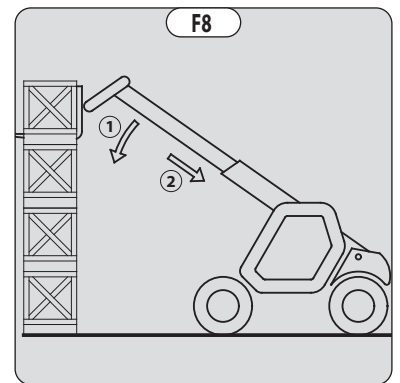
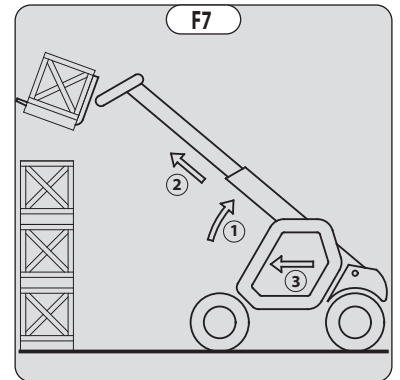
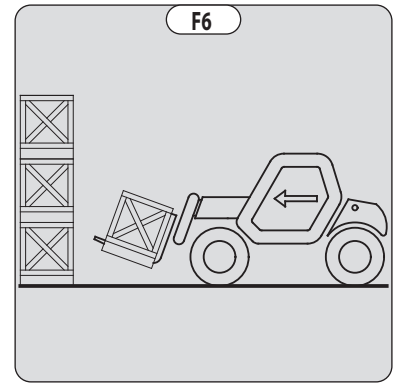

## G - PICKING UP AND PUTTING DOWN A HIGH LOAD ON STABILIZERS

Depending on machine model

### **⚠ IMPORTANT ⚠**

*You must not raise the boom if you have not checked the transverse attitude of the machine (← INSTRUCTIONS FOR HANDLING A LOAD D - TRANSVERSE ATTITUDE OF THE MACHINE).*

REMINDER: Make sure that the following operations can be performed with good visibility (← OPERATING INSTRUCTIONS UNLADEN AND LADEN: D - VISIBILITY).

The stabilizers are used to optimize the machine's lifting performance (← 2 - DESCRIPTION: INSTRUMENTS AND CONTROLS).

POSITIONING THE STABILIZERS WITH THE FORKS IN TRANSPORT POSITION (UNLADEN AND LADEN)

- Set the forks in transport position in front of the elevation.
- Stay far enough away to allow the boom to be raised.
- Activate the parking brake and place the forward/reverse selector in neutral.
- Set the two stabilizers on the ground and lift the two front wheels of the machine (fig. G1), while maintaining its transverse stability.

RAISING THE STABILIZERS WITH THE FORKS IN TRANSPORT POSITION (UNLADEN AND LADEN)

- Raise both stabilizers fully and at the same time.

LOWERING THE STABILIZERS WITH JIB UP (UNLADEN AND LADEN)

### **⚠ IMPORTANT ⚠**

*This operation must be exceptional and performed with great care.*

- Raise the boom and retract the telescopes completely.
- Set the machine in position in front of the elevation (fig. G2), moving very slowly and carefully.
- Activate the parking brake and place the forward/reverse selector in neutral.
- Move the stabilizers very slowly and gradually as soon as they are close to the ground or in contact with it.
- Lower the two stabilizers and lift the two front wheels of the machine (fig. G3). During this operation, transverse attitude must be permanently maintained: the bubble in the level must be kept between the two lines.

SETTING THE STABILIZERS WITH THE BOOM UP (UNLADEN AND LADEN)

### **⚠ IMPORTANT ⚠**

*This operation must be exceptional and performed with great care.*

- Keep the boom raised and retract the telescopes completely (Fig. G3).
- Move the stabilizers very slowly and gradually as soon as they are in contact with the ground and when they leave the ground. During this operation, transverse attitude must be permanently maintained: the bubble in the level must be kept between the two lines.
- Raise both stabilizers completely.
- Deactivate the parking brake and reverse the machine (1) very slowly and carefully to release it and lower the forks (2) into transport position (fig. G4).

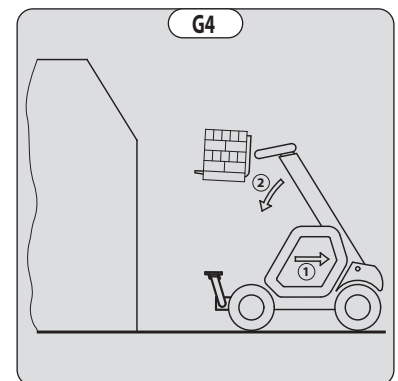
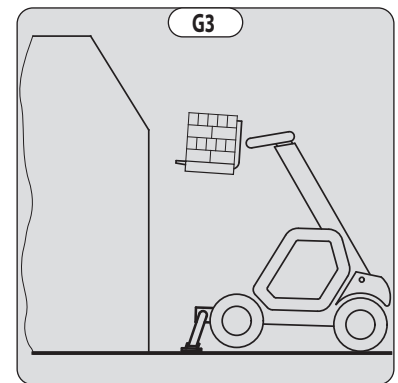
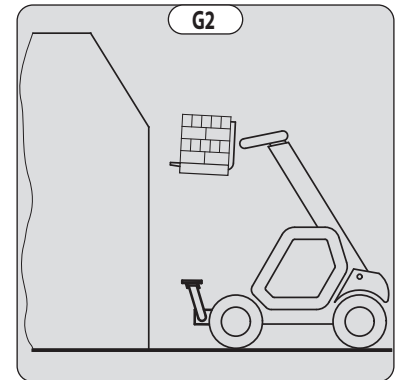
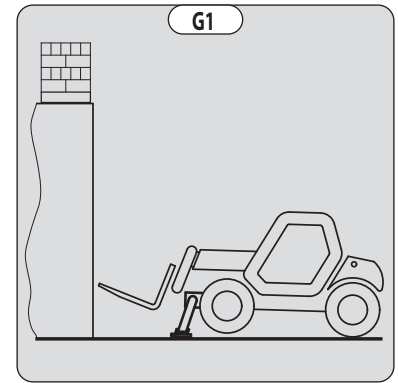

## PICKING UP A HIGH LOAD ON STABILIZERS

- Ensure that the forks will easily pass under the load.
- Check the position of the machine with respect to the load and make a test run, if necessary, without picking up the load.
- Raise and extend the boom (1) (2) until the forks are at the level of the load (Fig. G5).
- Bring the forks to the stop in front of the load by alternately extending and lowering the boom (1) (Fig. G6).
- Lift the load slightly (1) and tilt the carriage (2) backwards to stabilize the load (Fig. G7).
- Monitor the longitudinal stability indicator (⚠ INSTRUCTIONS FOR HANDLING A LOAD: C - LONGITUDINAL STABILITY INDICATOR). If it is overloaded, set the load back down in the place from which it was picked up.
- If possible, lower the load without moving the machine. Raise the boom (1) to release the load, retract (2) and lower the jib (3) to set the load into transport position (fig. G8).

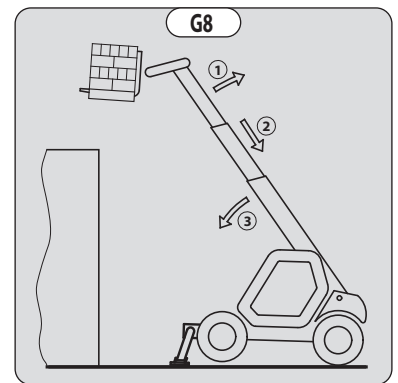
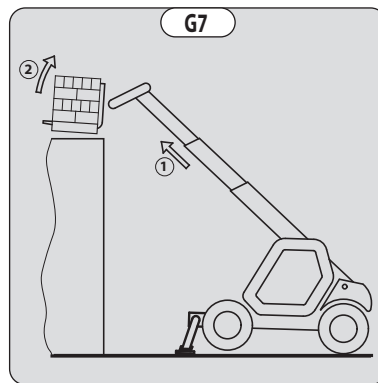
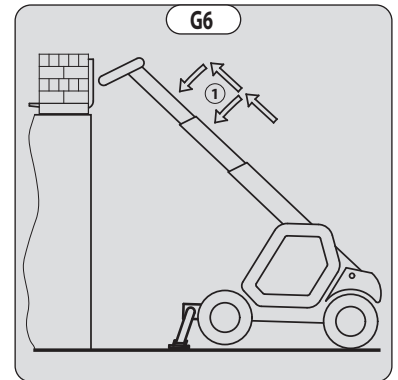
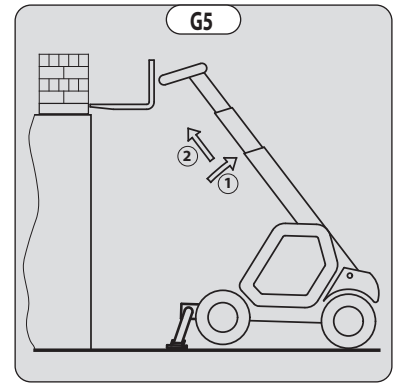

## SETTING DOWN A HIGH LOAD ON STABILIZERS

- Raise and extend the boom (1) (2) until the load is above the elevation (fig. G9), while monitoring the longitudinal stability indicator (⚠ INSTRUCTIONS FOR HANDLING A LOAD: C - LONGITUDINAL STABILITY INDICATOR).
- Position the load horizontally and release it by lowering and retracting the boom (1) (2) to position the load correctly (Fig. G10).
- Free the forks by alternately retracting and raising the boom (3) (Fig. G11).
- If possible, set the boom in transport position without moving the machine.

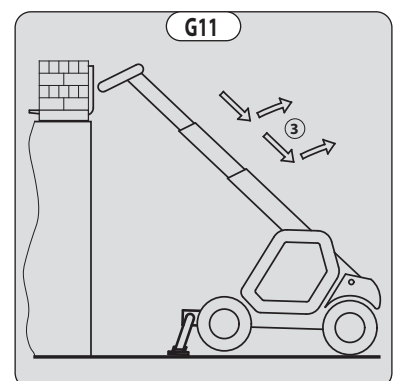
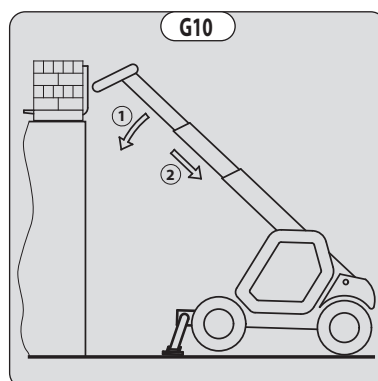
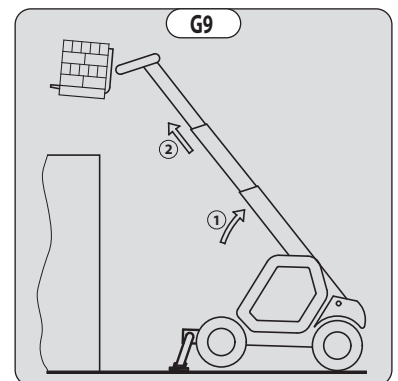

## H - PICKING UP AND PUTTING DOWN A SUSPENDED LOAD

### **⚠ IMPORTANT ⚠**

*Failure to follow the above instructions may lead the machine to lose stability and overturn.  
MUST be used with a machine equipped with an operational hydraulic movement cut-off device.*

#### CONDITIONS OF USE

- The length of the sling or the chain shall be as short as possible to limit swinging of the load.
- Lift the load vertically along its axis, never by pulling sideways or lengthways.

#### HANDLING WITHOUT MOVING THE MACHINE

- Whether on stabilizers or on tires, the lateral attitude must not exceed 1% and the longitudinal attitude must not exceed 5%: the bubble of the level must be held at "0".
- Ensure that the wind speed is not higher than 10 m/s (32,8 fps).
- Ensure that there is no one between the load and the machine.

#### I - TRAVELING WITH A SUSPENDED LOAD

- Before moving, inspect the terrain in order to avoid excessive slopes and cross-falls, bumps and potholes, or soft ground.
- Ensure that the wind speed is not higher 36 km/h (22.37 mph).
- The machine must not travel at more than 0.4 m/s (1.5 km/h (0.93 mph), i.e. one quarter walking speed).
- Drive and stop the machine gently and smoothly to minimize swinging of the load.
- Carry the load a few centimeters above the ground (max. 30 cm (11.81 in) the shortest possible jib length. Do not exceed the offset indicated on the load chart. If the load begins to swing excessively, do not hesitate to stop and lower the jib to set down the load.
- During transport, the lift truck operator must be assisted by a person on the ground (standing a minimum of 3 m (9-10.11 ft-in) from the load), who will limit swinging of the load using a bar or a rope. Ensure that this person is always clearly in view.
- The lateral attitude must not exceed 5%: the bubble in the level must be kept between the two "MAX" marks.
- The longitudinal attitude must not exceed 15% with the load facing uphill and 10% with the load facing downhill.
- The boom angle must not exceed 45°..

## INSTRUCTIONS FOR USE AS A LOADER

For agricultural-type machines (MLT range)

### A - LOADING

#### ⚠ IMPORTANT ⚠

*You must not raise the boom if you have not checked the transverse attitude of the machine (← INSTRUCTIONS FOR HANDLING A LOAD D - TRANSVERSE ATTITUDE OF THE MACHINE).*

REMINDER: Make sure that the following operations can be performed with good visibility (← OPERATING INSTRUCTIONS UNLADEN AND LADEN: D - VISIBILITY).

#### FILLING THE BUCKET

- Place the bottom of the bucket in a horizontal position, just in contact with the ground (1) (Fig. A1).
- Move forward gradually (2) while simultaneously raising the boom and tilting the bucket backwards (3), for improved filling and breakout (Fig. A1).
- Reverse the machine (1) very carefully and gently to free the bucket. Lower the boom (2) into the transport position (Fig. A2).

#### ⚠ IMPORTANT ⚠

*Tilt the bucket sufficiently back to avoid spilling product and ensure its stability (loss of product under braking).*

#### LOADING A TRAILER

- Approach the side of the trailer in the transport position (Fig. A3).
- Raise and extend the boom (1) (2) until the bucket is above the trailer, while monitoring the longitudinal stability indicator (← INSTRUCTIONS FOR HANDLING A LOAD: C - LONGITUDINAL STABILITY INDICATOR) (fig. A4).
- Drive the machine forward (3) very carefully and gently so that the bucket empties its load in the center of the trailer (Fig. A4).
- Immobilize the machine with the service brake pedal and put the reversing shift lever in neutral.

N.B.: Immobilizing the machine with the service brakes means that the transmission should be in neutral. Failure to follow this recommendation may lead to overheating and damage to the brakes.

- Slowly discharge the product (4) (Fig. A4).
- Tilt the bucket backwards (1) and reverse the machine (2) very carefully and gently (Fig. A5).
- Retract (3) and lower the boom (4) into the transport position (Fig. A5).

### B - BACKFILLING

- Place the bottom of the bucket in a horizontal position, just in contact with the ground (1) (Fig. B1).
- Drive forward gradually (2). Once filled, the bucket will act as a leveling blade (Fig. B1).

#### ⚠ IMPORTANT ⚠

*When driving, beware of trenches as well as recently excavated and/or backfilled ground.*

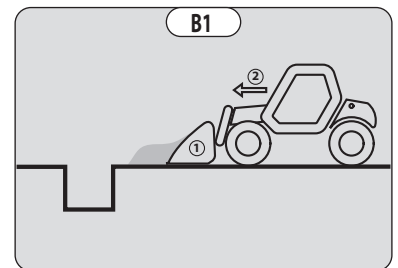
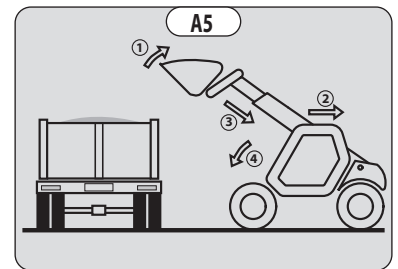
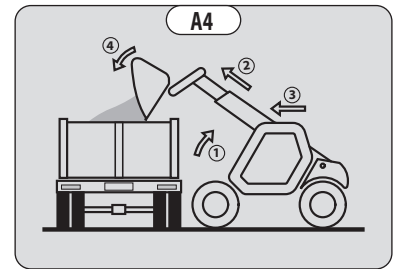
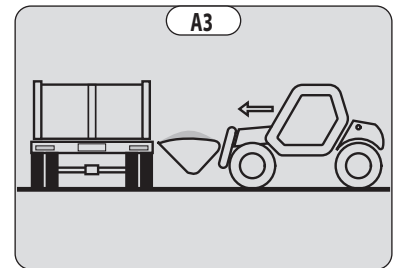
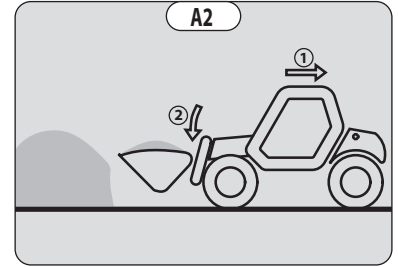
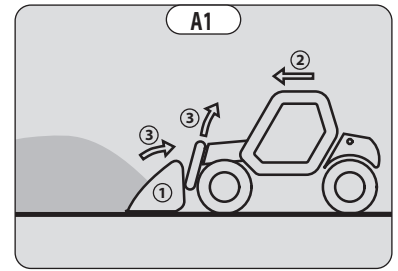

## **INSTRUCTIONS FOR USING THE MOBILE ELEVATING WORK PLATFORM**

---

For machines equipped with a MOBILE ELEVATING WORK PLATFORM

### **A - AUTHORIZATION FOR USE**

- Operation of the platform requires further authorization in addition to that of the machine.

### **B - SUITABILITY OF THE PLATFORM FOR THE JOB**

- Our machines fitted with mobile elevating work platforms are compliant with standard **EN 280** for Europe and standard **AS/NZS 1418.10:2011** for Australia, corresponding to the classification of Group C1 to C3 in accordance with this standard.
- MANITOU has ensured that this platform is suitable for use under the normal operating conditions provided in this operator's manual, with a STATIC test coefficient of 1.25 and a DYNAMIC test coefficient of 1.1 as specified in harmonized European standard **EN 280** for mobile elevating work platforms.
- Before commissioning, the company manager must make sure that the platform is appropriate for the work to be done, and perform certain tests (in accordance with current legislation).

### **C - PROVIDED ON THE PLATFORM**

- Wear suitable clothing when using the platform, avoid loose-fitting garments.
- Never use the platform with hands or shoes that are wet or soiled with greasy substances.
- Remain alert at all times when using the platform. Do not listen to the radio or music using headphones or earphones.
- MANITOU strongly recommends wearing a safety harness attached to an attachment point in the platform. Wearing a safety harness or other personal protection equipment against falls may be compulsory. Comply with local, government and national regulations in force, employer's safety rules and work site regulations .
- The safety harness or other personal protection equipment against falls must comply with local, government, and national regulations in force. They must be inspected in accordance with the regulations in force.
- The control units must never be used for any other than their intended purposes (e.g. Climbing onto or down from the machine, coat hanger, etc.).
- Safety helmets must be worn.
- The operator must always be in his normal position in the driver's cab: it is prohibited to have arms or legs, or generally any part of the body, outside the platform.
- Ensure that materials loaded onto the platform (pipes, cables, containers, etc.) cannot fall out. Do not pile these materials to the point where it is necessary to step over them.

## D - USING THE PLATFORM

- However experienced they may be, operators must acquaint themselves with the emplacement and operation of all control instruments prior to operating the platform.
- Check before use that the platform has been correctly assembled and locked onto the machine.
- Do not enter or exit the platform unless it is fully lowered.
- Always enter and exit the platform through the gate or using the sliding intermediate cross members (depending on the model).
- Always enter and exit facing the interior of the platform.
- Always use both hands and one foot or both feet and one hand to enter and exit the platform.
- Make sure that the sliding intermediate cross members (depending on the model) are in the lower position and that the gate is properly closed (depending on the model) before using this platform.
- Do not attach the sliding mid rails in the high position.
- The platform should be operated in an area free of any obstructions or danger when it is lowered to the ground.
- The operator using the platform must be aided by someone on the ground with adequate training.
- You should stay within the limits set out in the platform load chart.
- The lateral constraints are limited (↩ 2 - DESCRIPTION: SPECIFICATIONS).
- It is strictly forbidden to suspend a load from the platform or the machine's boom without an attachment provided for the purpose (↩ INSTRUCTIONS FOR HANDLING A LOAD: H - PICKING UP AND PUTTING DOWN A SUSPENDED LOAD).
- The platform cannot be used as a crane or a lift for permanently transporting people or materials, nor as jacks or supports.
- The machine must not be moved with one (or more) person(s) on the platform.
- It is forbidden to transport people on the platform using the hydraulic controls in the machine's cab (except in case of rescue).
- The operator must not climb onto to off the platform when it is not on ground level (jib retracted and in the down position).
- The machine must not be fitted with unauthorized attachments that increase the windage of the assembly.
- Do not use ladders or improvised structures on the platform to gain extra height.
- Do not climb onto the rails of the platform to gain extra height.
- It is forbidden to use the platform on forks. The fork slots are only to, be used for storing the platform and not for lifting people under any circumstances.

**E - ENVIRONMENT**

- Respect a safety distance between power lines or live components and any part of the body, any conductive object or any part of the machine, unless the local, government and national applicable regulations, the safety rules of the employer or construction site regulations are more strict in terms of distance required.
- Allow for platform movement and swaying or sagging power lines.

**⚠ IMPORTANT ⚠**

*It is forbidden to use the platform close to electricity cables. Maintain the specified safe distances.*

RATED VOLTAGE (VOLTS)	SAFETY DISTANCE (FT-IN/METRES)
50 < U < 1000	7-6.55/2,30
1000 < U < 30000	8-2.42/2,50
30000 < U < 45000	8-6.36/2,60
45000 < U < 63000	9-2.23/2,80
63000 < U < 90000	9-10.11/3,00
90000 < U < 150000	11-1.85/3,40
150000 < U < 225000	13-1.48/4,00
225000 < U < 400000	17-4.66/5,30
400000 < U < 750000	25-11.02/7,90

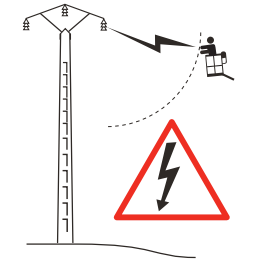

**⚠ IMPORTANT ⚠**

*It is strictly forbidden to use the platform when the wind speed exceeds 45 km/h (27.96 mph).*

To visually recognize this wind speed, refer to the empirical wind evaluation scale below:

BEAUFORT scale (wind speed at a height of 32-9,7 ft-in (10 m) on a flat site)							
Force	Type of wind	Speed (knots)	Speed (mph)	Speed (km/h)	Speed (m/s)	Effects on Land	Sea conditions
0	Calm	0 - 1	0 - 1	0 - 1	<0.3	Smoke rises vertically.	Sea is like a mirror.
1	Light air	1 - 3	1 - 3	1 - 5	0.3 - 1.5	Smoke indicates direction of wind.	Ripples with appearance of scale, no foam crests.
2	Light breeze	4 - 6	4 - 7	6 - 11	1.6 - 3.3	Wind felt on face, leaves rustle.	Short wavelets, but pronounced.
3	Gentle breeze	7 - 10	8 - 12	12 - 19	3.4 - 5.4	Leaves and small twigs in constant motion.	Very small waves, crests begin to break.
4	Moderate breeze	11 - 16	13 - 18	20 - 28	5.5 - 7.9	Wind raises dust and loose pieces of paper; small branches are moved.	Small waves, becoming longer, numerous whitecaps.
5	Fresh breeze	17 - 21	19 - 24	29 - 38	8 - 10.7	Small trees in leaf begin to sway.	Wavelets form on inland waters; moderate waves, taking longer form.
6	Strong breeze	22 - 27	25 - 31	39 - 49	10.8 - 13.8	Large branches in motion, whistling heard in overhead wires, umbrella use becomes difficult.	Larger waves forming, whitecaps everywhere, some spray.
7	Near gale	28 - 33	32 - 38	50 - 61	13.9 - 17.1	Whole trees in motion, inconvenience felt when walking against the wind.	Sea heaps up; white foam from breaking waves begins to be blown in streaks along the direction of the wind.
8	Gale	34 - 40	39 - 46	62 - 74	17.2 - 20.7	Wind breaks twigs off trees; impedes progress.	Moderately high waves of greater length; edges of crests begin to break into spindrift.
9	Strong gale	41 - 47	47 - 54	75 - 88	20.8 - 24.4	Wind damages roofs (chimneys, slates, etc.).	High waves, crests of waves begin to topple, streaks of foam; reduced visibility.
10	Storm	48 - 55	55 - 63	89 - 102	24.5 - 28.4	Seldom experienced inland; trees uprooted; considerable structural damage occurs.	Very high waves; white streaks of foam; reduced visibility.
11	Violent storm	56 - 63	64 - 72	103 - 117	28.5 - 32.6	Very rare, widespread damage.	Exceptionally high waves able to hide medium sized ships from view, reduced visibility.
12	Hurricane	64 +	72 +	118 +	32.7 +	Devastating damage.	Sea completely white; air filled with foam and spray, very reduced visibility.

**F - MAINTENANCE**

**⚠ IMPORTANT ⚠**

*Your platform must be periodically inspected to ensure its continued compliance. The frequency of this inspection is defined by the legislation in force in the country in which the platform is used. In France, a general periodic inspection every 6 months (Decree of March 1, 2004).*

## INSTRUCTIONS FOR USING THE RADIO-CONTROL

For machines with RC radio control

### HOW TO USE THE RADIO-CONTROL

#### SAFETY INSTRUCTIONS

#### **⚠ IMPORTANT ⚠**

*It is prohibited to lift people in the platform using the radio-control.*

*It is prohibited to use the radio-control from the platform:*

- This radio-control consists of electronic and mechanical safety elements. It cannot receive commands from another transmitter because the internal encoding is unique to each radio-control.

#### **⚠ IMPORTANT ⚠**

*If it is used improperly or incorrectly, there is a risk of danger to:*

*- The physical and mental health of the user or others.*

*- The machine and other neighboring items.*

*Everyone working with this radio-control:*

*- Must be qualified in line with current regulations and trained accordingly.*

*- Must follow this instruction manual as closely as possible.*

- The system is used to control the machine remotely via radio waves. Commands are also transmitted if the machine is out of sight (behind an obstacle or a building for example), this is why:
  - After stopping the truck and removing the key switch (only possible when it is stationary), always place the transmitter in a safe, dry place.
  - Before performing any installation, servicing or repair work, always switch off power sources (in particular, electric welding devices and electric head units on hydraulic distributors must be disconnected at each section).
  - Never remove or alter the safety devices (such as the hand-guard frame, key, emergency stop button, etc.).

#### **⚠ IMPORTANT ⚠**

*Never drive the machine if it is not continuously and perfectly within view of the operator.*

- Before leaving the transmitter, the operator must make sure that it cannot be used by an unauthorized third person: either by removing the key button from the transmitter or locking it in an inaccessible place.
- The user must ensure that the instruction manual is accessible at all times and that operators have read and understood it.

#### INSTRUCTIONS

- Take up position in a stable place with no risk of slipping.
- Before using the transmitter, make sure there is nobody within the working area.
- Only use the transmitter with its carrying device or installed correctly on the platform.

#### **⚠ IMPORTANT ⚠**

*When you remove the transmitter, remove the accumulator and key button so that it cannot be used accidentally or deliberately by anyone else.*

#### PROTECTIVE DEVICES

- The machine will be immobilized within a maximum of 450 milliseconds (approx. 0.5 second):
  - If the emergency stop button of the transmitter is pressed (50 milliseconds), or that of the machine.
  - If the transmission distance of the radio waves is exceeded.
  - If the transmitter is faulty.
  - If an interfering radio signal is received from elsewhere.
  - If the accumulator is removed from its housing in the transmitter.
  - If the battery reaches the end of its autonomy.
  - If the transmitter is switched off by turning the key switch to the off position.
- These protective devices are provided for the safety of personnel and property and must never be modified, removed or bypassed in any way whatsoever!
- The hand-guard frame prevents external action on a joystick (e.g. if the transmitter is dropped, or if the operator leans on a guard-rail).
- An electronic safety device prevents radio transmission from being initiated if the joysticks are not mechanically and electrically at rest and if the internal combustion engine speed selector is not set to idle.

#### **⚠ IMPORTANT ⚠**

*In an emergency, press the transmitter emergency stop button immediately; then follow the manual's instructions (← 2 - DESCRIPTION: INSTRUMENTS AND CONTROLS).*

# MACHINE MAINTENANCE INSTRUCTIONS

## GENERAL INSTRUCTIONS

- Make sure the area is adequately ventilated before starting up the machine.
- Wear clothes suitable for the maintenance of the machine. Avoid wearing jewelry and loose clothes. Tie back and protect your hair, if necessary.
- Stop the engine and remove the ignition key before carrying out any work.
- Read the operator's manual carefully.
- Carry out all repairs immediately, even if the repairs concerned are minor.
- Repair all leaks immediately, even if the leak concerned is minor.
- Ensure that process materials and of spare parts are disposed in all safely and in an ecological manner.
- Be careful of the risk of burning and splashing (exhaust, radiator, engine, etc.).

## PLACING THE JIB SAFETY WEDGE

- The machine is equipped with a boom safety wedge (↖ 2 - DESCRIPTION: INSTRUMENTS AND CONTROLS) that must be installed on the lifting cylinder rod when working beneath the boom.

### FITTING THE WEDGE

- Fully raise the jib.
- Place the safety wedge 1 on the rod of the lifting cylinder and secure with the rod 2 and the pin 3.
- Slowly lower the jib then stop the hydraulic movements before it comes into contact with the wedge.

### REMOVING THE WEDGE

- Fully raise the jib.
- Remove the pin and the rod.
- Return the safety wedge to the storage location provided on the machine.

**⚠ IMPORTANT ⚠**

*Only use the wedge supplied with the machine.*

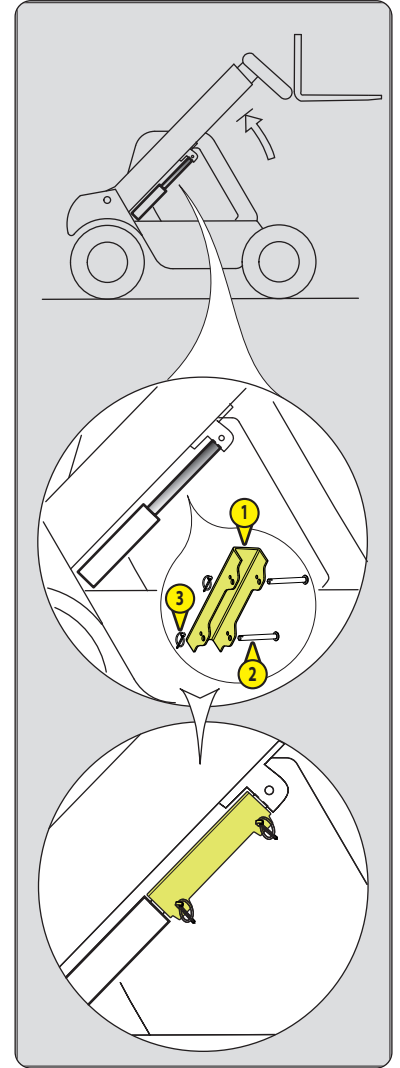

## MAINTENANCE

- Perform the periodic service (↖ 3 - MAINTENANCE) to keep your machine in good working order. Failure to perform periodic maintenance may invalidate the contractual warranty.

### MAINTENANCE LOGBOOK

- The maintenance operations carried out in accordance with the recommendations given in Part: 3 - MAINTENANCE and the other inspection, servicing or repair operations or modifications performed on the machine or its attachments should be recorded in a maintenance logbook. The entry for each operation should include the date of the work, the names of the individuals or companies having performed them, the type of operation and its frequency, if applicable. If machine elements are replaced, the part numbers of these elements shall be indicated.

## LUBRICANT AND FUEL LEVELS

---

- Use the recommended lubricants (never use contaminated lubricants).
- Do not fill the fuel tank when the engine is running.
- Only fill up the fuel tank in areas specified for this purpose.
- Do not fill the fuel tank to the maximum level.
- Do not smoke or approach the machine with a flame when the fuel tank is open or is being filled.

## HYDRAULICS

---

- Any work on the load handling hydraulic circuit is forbidden except for the operations described in chapter: 3 - MAINTENANCE.
- Do not attempt to loosen unions, hoses or any hydraulic component with the circuit under pressure.

### **IMPORTANT**

**COUNTERBALANCE VALVE:** It is dangerous to change the setting or remove the balancing valves or safety valves which may be fitted to your machine cylinders. The HYDRAULIC ACCUMULATORS which may be fitted on your machine are pressurized units. Removing them and their pipework is dangerous. operation and must only be performed by approved personnel (consult your dealer).

## ELECTRICITY

---

- Do not short-circuit the starter relay to start the engine. If the forward/reverse selector is not in neutral and the parking brake is not on, the machine may suddenly start to move.
- Do not place metal items on the battery.
- Disconnect the battery before working on the electrical circuit.

## WELDING

---

- Disconnect the battery before any welding operations on the machine.
- When carrying out electric welding work on the machine, connect the negative cable from the equipment directly to the part being welded so as to avoid very high current passing through the alternator.
- Never carry out welding or work which gives off heat on an assembled tire. The heat would increase the pressure which could cause the tire to explode.
- If the machine is equipped with an electronic control unit, disconnect it before starting to weld so as to avoid the risk of causing irreparable damage to electronic components.

## WASHING THE MACHINE

---

- Clean the machine or at least the area concerned before any intervention.
- Remember to close and lock all openings on the machine (doors, windows, cowls, etc.).
- During washing, avoid the articulations and electrical components and connections.
- If necessary, protect against penetration of water, steam or cleaning agents, components susceptible of being damaged, particularly electrical components and connections and the injection pump.
- Clean the machine of any traces of fuel, oil or grease.

## TRANSPORTING THE MACHINE

---

### **IMPORTANT**

**Transporting the machine involves real risks for the operator and others involved.**

- Towing, winching, slinging or transporting the machine (< 3 - MAINTENANCE).

## PROLONGED MACHINE SHUTDOWN

### INTRODUCTION

#### **⚠ IMPORTANT ⚠**

*Procedures to follow for long duration standstill and for bringing back the machine into service must be performed by your dealership.*

*This period of long duration standstill must not exceed 12 months.*

*After 12 months, repeat the procedures for putting the machine back into service and long-term shutdown.*

The recommendations below are intended to prevent the machine from being damaged when it is not used for a period of more than 3 months.

### PREPARATION OF THE MACHINE

- Clean the machine thoroughly.
- Check and repair any fuel, oil, water or air leaks.
- Replace or repair any worn or damaged parts.
- Wash the painted surfaces of the machine in clear and cold water and wipe them.
- Touch up the paintwork if necessary.
- Shut down the machine (◀ OPERATING INSTRUCTIONS UNLADEN AND LADEN).
- Make sure the boom cylinder rods are all in the retracted position.
- Release the pressure in the hydraulic circuits.

### DEF (Diesel Exhaust Fluid) TANK

Depending on machine model

- Empty and rinse the DEF tank.
- Replace the "DEF" (Diesel Exhaust Fluid) supply pump filter (◀ 3 - MAINTENANCE).
- Slowly fill the tank with new "DEF" (Diesel Exhaust Fluid) up to the bottom of the filler neck.
- Start up the machine to pressurize the circuit and bring it up to working temperature, then shut down the engine.
- If necessary, top up the tank.

### PROTECTING THE ENGINE

- Contact your dealer to obtain the procedure for protecting the inside of the engine (use of protection product).
- Fill the tank with fuel (◀ 3 - MAINTENANCE).
- Drain and replace the coolant (◀ 3 - MAINTENANCE).
- Leave the engine running at idling speed for a few minutes, then switch off.
- Replace the engine oil and oil filter (◀ 3 - MAINTENANCE).
- Run the engine for a short time so that the oil and cooling liquid circulate inside.
- Disconnect the battery and store it in a safe place away from the cold, after charging it to maximum capacity.
- Block the outlet with waterproof adhesive tape.
- Remove the drive belts and store them in a safe place.
- Disconnect the engine cut-off solenoid on the injection pump and carefully insulate the connection.

### MACHINE PROTECTION

Place the machine on level ground.

- Set the machine on axle stands so that the tires are off the ground.
- Deactivate the parking brake (depending on machine model).
- Protect cylinder rods which will not be retracted from corrosion.
- Protect the wheels.

N.B.: If the machine is to be stored outdoors, cover it with a waterproof tarpaulin.

## RETURNING THE MACHINE TO SERVICE

---

- Remove the waterproof adhesive tape from all the orifices.
- Remove the protection from the cylinder rods and wheels.
- Refit and reconnect the battery.
- Perform the daily maintenance operations (↩ 3 - MAINTENANCE).
- Perform the weekly maintenance operations (↩ 3 - MAINTENANCE).
- Activate the parking brake and remove the axle stands.
- Drain and clean the fuel tank (↩ 3 - MAINTENANCE).
- Fill the fuel tank with clean diesel filtered through the filler port.
- Replace the fuel filter (↩ 3 - MAINTENANCE).
- Replace the fuel pre-filter (↩ 3 - MAINTENANCE) (depending on the model of machine).
- Drain and rinse the DEF tank (depending on the machine model).
- Top up, slowly fill the tank with new "DEF" (Diesel Exhaust Fluid) up to the bottom of the filler neck (depending on the machine model).
- Refit the drive belts and adjust the tension (↩ 3 - MAINTENANCE).
- Turn the engine over with the starter, to allow the oil pressure to rise.
- Reconnect the engine cut-off solenoid.
- Lubricate the machine completely (↩ 3 - MAINTENANCE).

**⚠ IMPORTANT ⚠**

*Make sure the area is adequately ventilated before starting up the machine.*

- Start up the machine, following the operating and safety instructions (↩ OPERATING INSTRUCTIONS UNLADEN AND LADEN).
- Carry out all the boom hydraulic movements, concentrating on the ends of travel for each cylinder.

## DISPOSING OF THE MACHINE

### **⚠ IMPORTANT ⚠**

*Consult your dealer before disposing of the machine.*

### **RECYCLING OF MATERIALS**

---

#### **METALS**

- Metals are 100% recoverable and recyclable.

#### **PLASTICS**

- Plastic parts are identified with a marking in accordance with current regulations.
- A limited range of materials is used to simplify the recycling process.
- The majority of the plastic components are made of "thermoplastic" plastics, which are easily recycled by melting, granulating or grinding.

#### **RUBBER**

- Tires and seals can be ground for use in cement manufacture or to obtain reusable granules.

#### **GLASS**

- Glass items can be removed and collected for processing by glaziers.

### **ENVIRONMENTAL PROTECTION**

---

By entrusting the maintenance of your machine to the MANITOU network, the risk of pollution is limited and the contribution to environmental protection is made.

#### **WORN OR DAMAGED PARTS**

- Do not dump them in the countryside.
- MANITOU and its network have signed-up to a scheme of environmental protection through recycling.

#### **USED OIL**

- The MANITOU network organizes the collection and processing of used oil.
- By handing over your waste oil to MANITOU, the risk of pollution is limited.

#### **USED BATTERIES**

- Do not throw away batteries, as they contain metals that are harmful for the environment.
- Return them to the MANITOU network or any other approved collection point.

N.B.: MANITOU aims to manufacture machines that provide the best performance and limit polluting emissions.

# ***2 - DESCRIPTION***



## 2 - DESCRIPTION

<b><u>SAFETY PLATES AND STICKERS</u></b>		<b>2-4</b>
<b><u>IDENTIFICATION OF THE LIFT TRUCK</u></b>		<b>2-8</b>
<b><u>SPECIFICATIONS</u></b>	<b>MLT 841 145 PS+ Y ST5 S1</b>	<b>2-10</b>
<b><u>SPECIFICATIONS</u></b>	<b>MLT 1041 145 PS+ L Y ST5 S1</b>	<b>2-12</b>
<b><u>TIRES</u></b>		<b>2-14</b>
<b><u>DIMENSIONS AND LOAD CHARTS</u></b>	<b>MLT 841 145 PS+ Y ST5 S1</b>	<b>2-18</b>
<b><u>DIMENSIONS AND LOAD CHARTS</u></b>	<b>MLT 1041 145 PS+ L Y ST5 S1</b>	<b>2-20</b>
<b><u>VISIBILITY</u></b>	<b>MLT 841 145 PS+ Y ST5 S1</b>	<b>2-22</b>
<b><u>VISIBILITY</u></b>	<b>MLT 1041 145 PS+ L Y ST5 S1</b>	<b>2-23</b>
<b><u>INSTRUMENTS AND CONTROLS</u></b>		<b>2-24</b>
<b><u>TOWING DEVICE</u></b>		<b>2-56</b>
<b><u>DESCRIPTION AND USE OF THE OPTIONS</u></b>		<b>2-62</b>

# SAFETY PLATES AND STICKERS

## ⚠ IMPORTANT ⚠

Clean all stickers and safety plates so that they are legible.  
 Any safety plates and stickers which are illegible or damaged must be replaced.  
 Check that stickers and safety plates are present after replacing any spare parts.

### EXTERNAL PLATES AND STICKERS

REF.	PART NO.	DESCRIPTION
1	52563320	- Tie-down point
2	296740	- Towing instruction
3	52705448	- Jack point
4	24653	- Slings point
5	305405	- Fuel
6	52694835	- Battery cut-off
7	52551668	- Air conditioning (OPTION)
8	288430	- Repair instruction
9	264476	- Boom electrical predisposition (OPTION)
10	296998	- Maniscopic safety instruction
11	234805	- Hydraulic coupling instruction
12	250707	- Ventilation reversal
13	288174	- Accumulator Instructions
14	52518055	- Battery troubleshooting

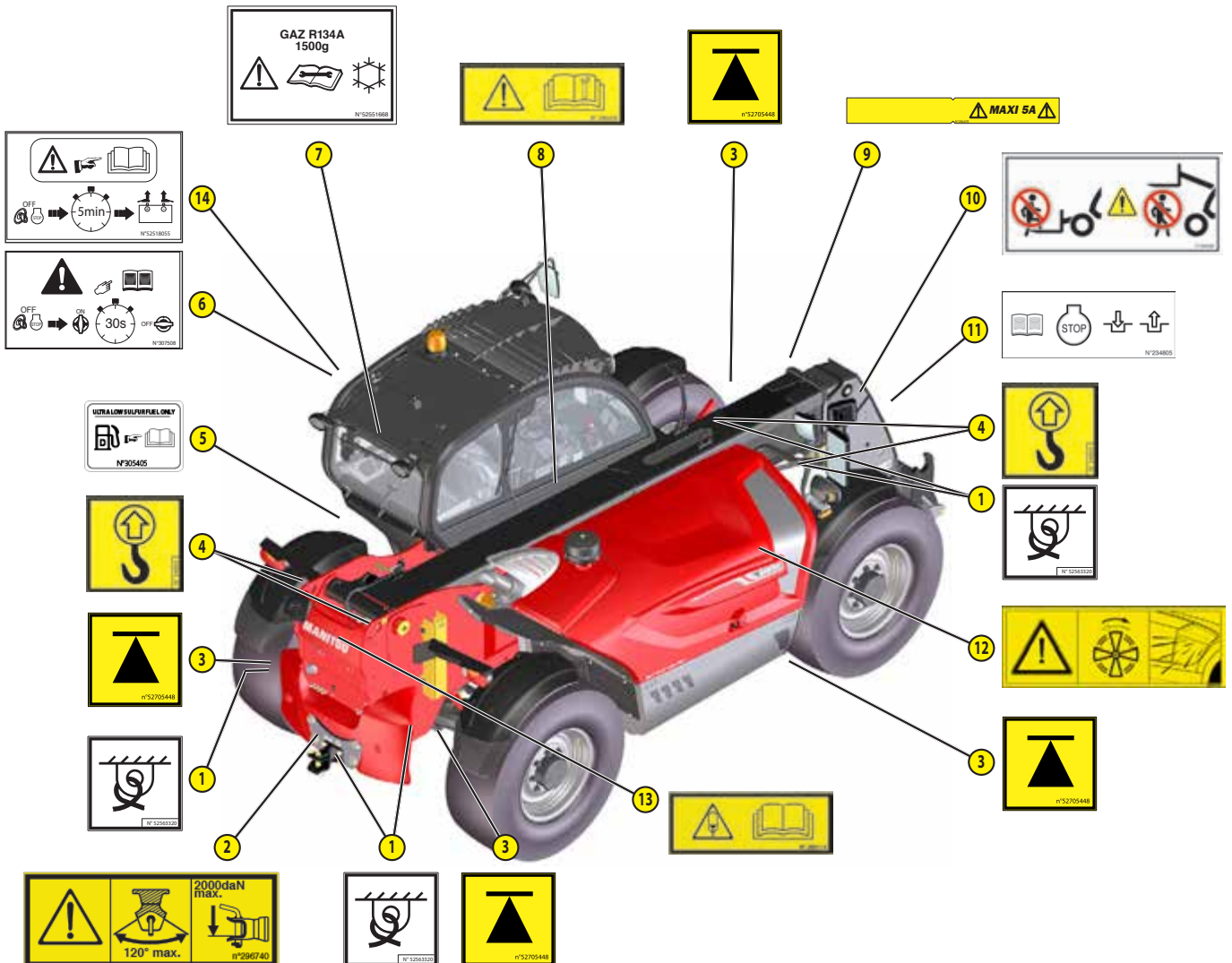

## STICKERS AND PLATES UNDER THE ENGINE HOOD

ITEM	PART No.	DESCRIPTION
1	259398	- Water/diesel separator
2	52501046	- Anti-freeze
3	52664803	- Engine fuse
4	296741	- "Do not mount" safety instruction
5	52588611	- Attachment and boom safety
5	52590031	- Attachment retaining shaft

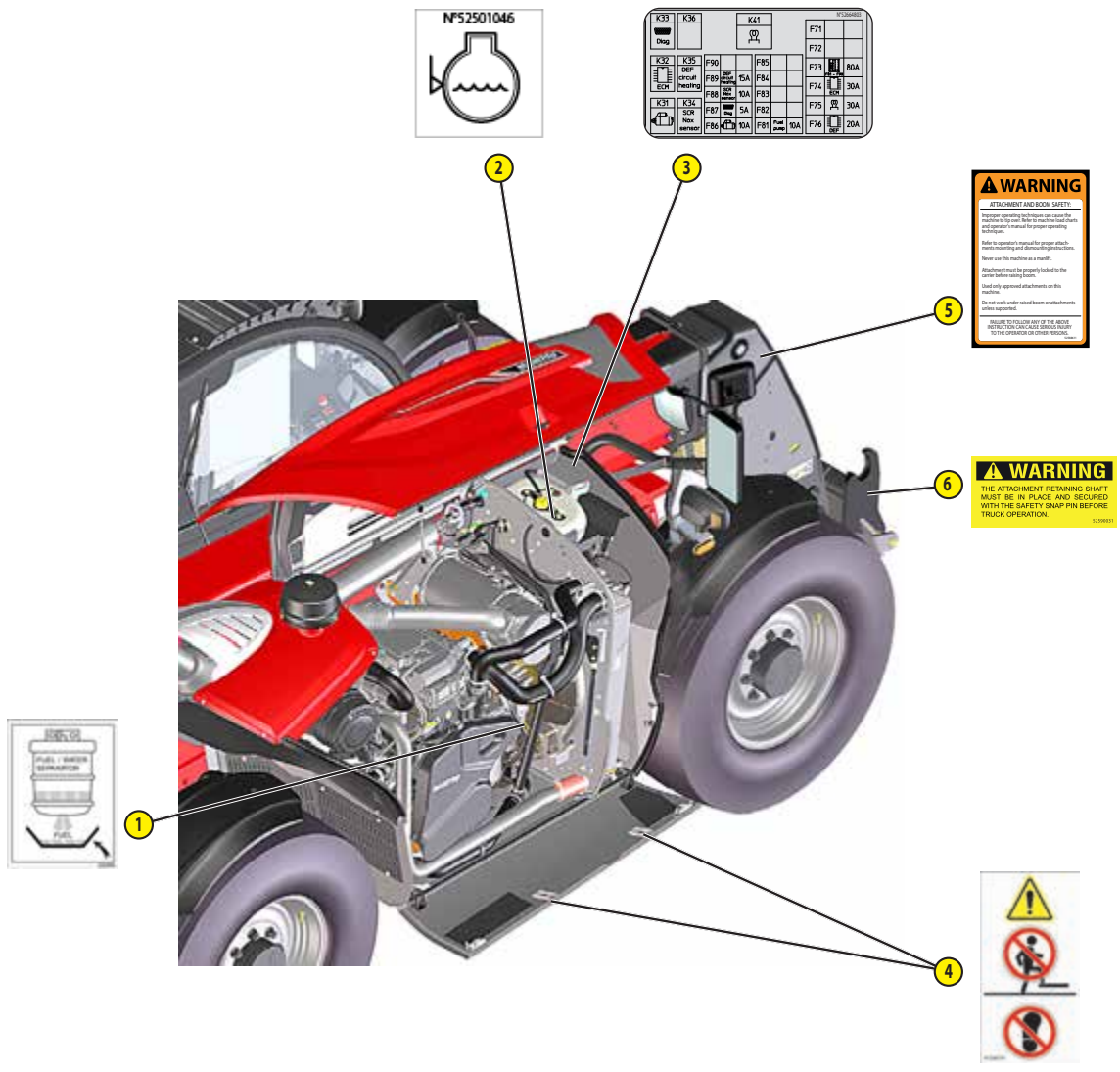

**PLATES AND STICKERS IN THE CAB**

REF.	PART NO.	DESCRIPTION
1	309219	- Boom position
2	52651762	- Hydraulic controls activation
4	52544967	- Switch pictograms
5	290183	- Bucket instruction on telescope
6	52664763	- Cab homologation
7	223324	- Patents
8	52579106	- Cab category 1
9	52567646	- Emergency exit
10	52715956	- Cab fuses
11	204079	- Hydraulic towing hook (OPTION)
12	52664800	- Cab compliance
13	239595	- Sound power level 105dB
14	52697439	- Fuel
15	52553497	- Reach chart sheet
16	241621	- Safety instruction
17	52664732	- Joystick function
18	52669922	- Joystick function 20 km/h (only for Germany)
19	52698381	- Tires <b>MLT 841</b>
20	52698382	- Tires <b>MLT 1041</b>
21	52710484	- Greasing instructions <b>MLT 841</b>
22	52710558	- Greasing instructions <b>MLT 1041</b>
23	52673886	- Hydraulic attachment locking (OPTION)
24	52674430	- Boom head electrovalve (OPTION)
25	52674427	- Boom head electrovalve + hydraulic attachment locking (OPTION)
26	52709999	- Hydraulic towing hook (OPTION)
27	52709510	- Hydraulic towing hook + double-acting predisposition (OPTION)
28	52709949	- Double-acting rear hydraulic predisposition joystick function
29	52709975	- Double-acting rear hydraulic predisposition double joystick function
30	52713063	- Consumption sheet <b>MLT 841</b>
31	52713087	- Consumption sheet <b>MLT 1041</b>
32	52588614	- No riders
33	52588617	- Seat belt
34	52588616	- DANGER leverage
35	52588615	- Power line
36	52618158	- PROP 65 warning plomb
37	52618159	- PROP 65 warning diesel engine exhaust
38	52628703	- ADH CAN ICES-2 NMB-2
34	52588612	- Before starting or operating

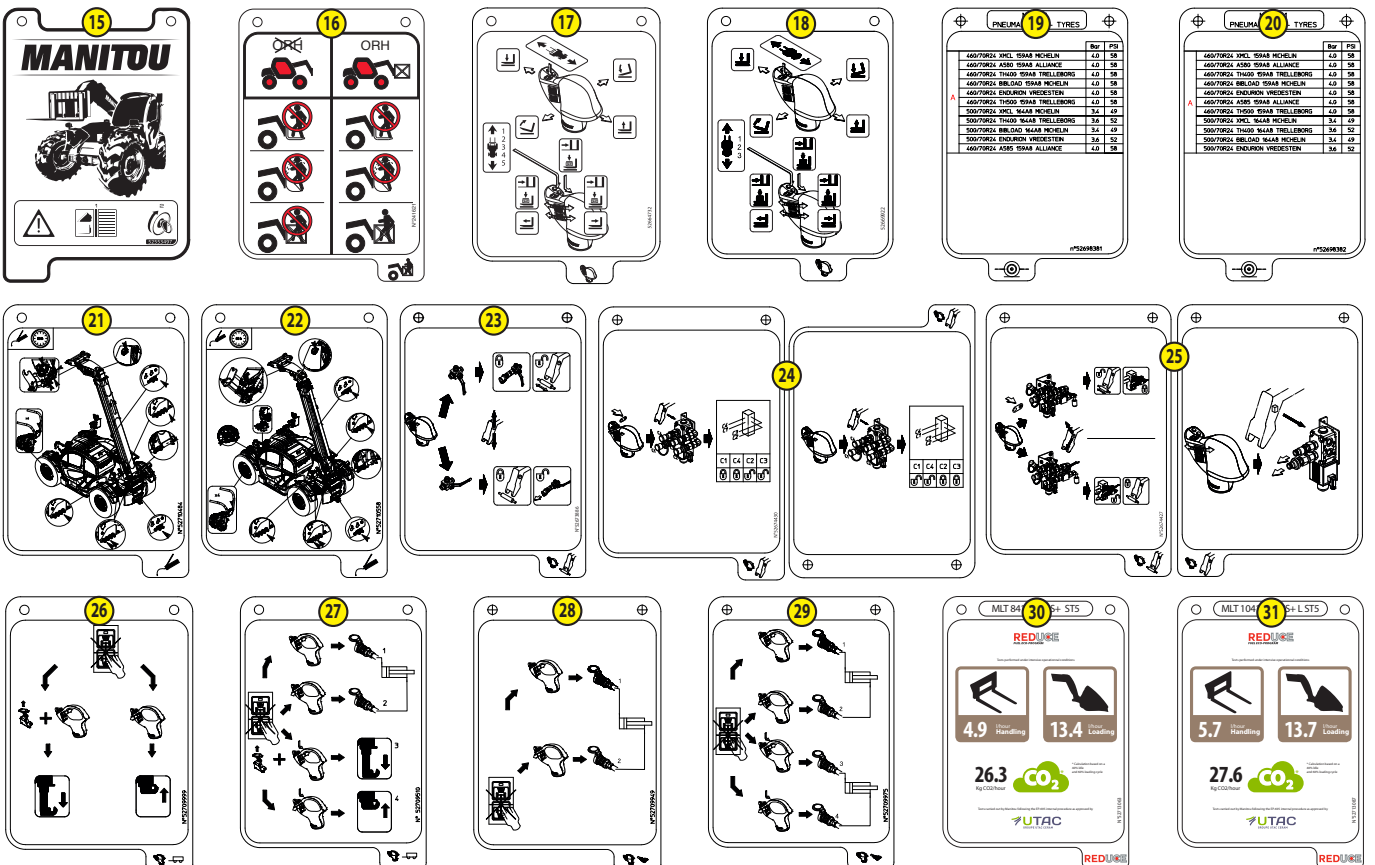

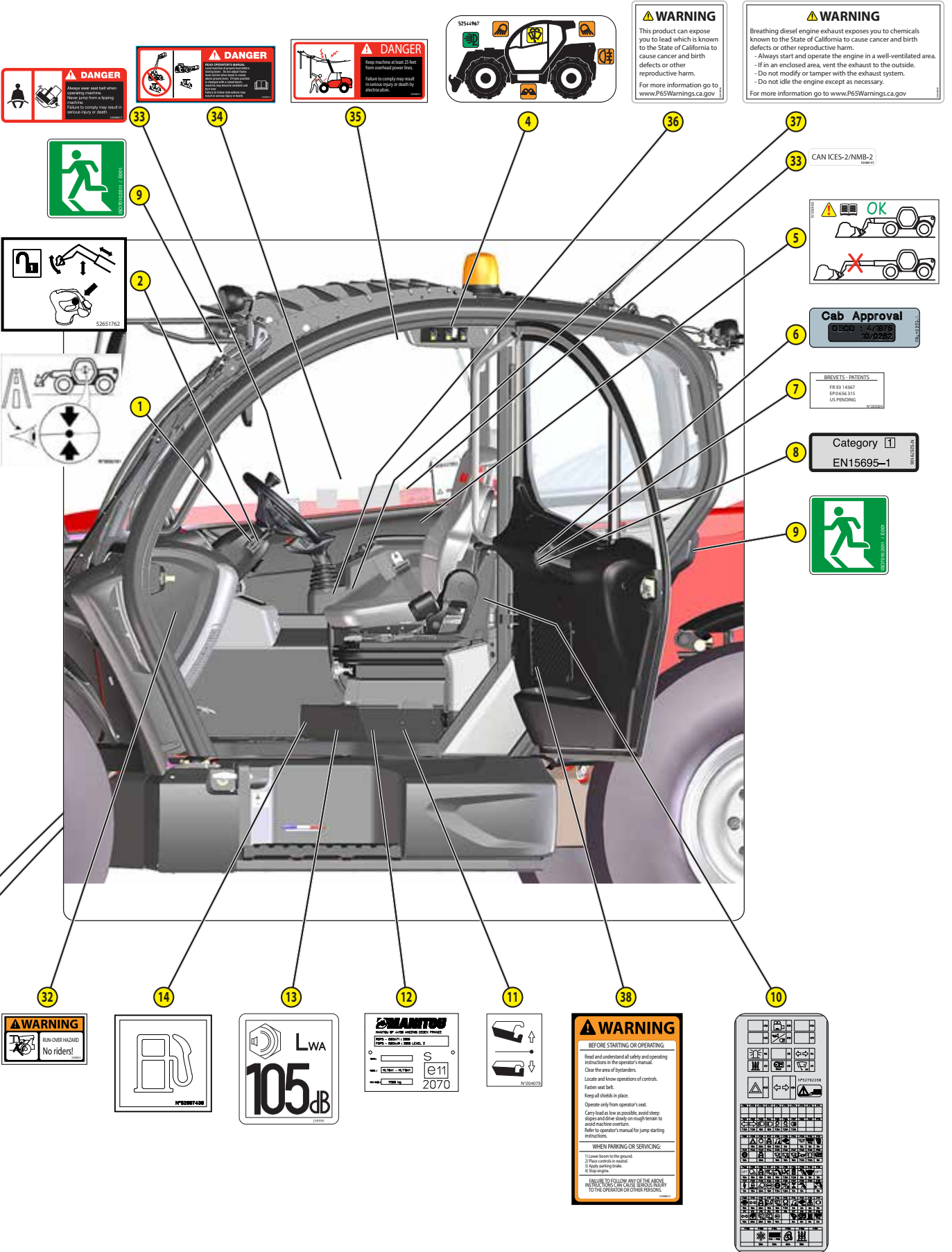

## IDENTIFICATION OF THE LIFT TRUCK

As our policy is to promote a constant improvement of our products, our range of lift trucks may undergo certain modifications, without any obligation for us to advise our customers.

When you order parts, or when you require any technical information, always specify the following information.

NOTE: For the owner's convenience, it is recommended that these numbers be entered in the spaces provided, at the time of the delivery of the lift truck.

For any further technical information regarding your lift truck, refer to: SPECIFICATIONS.

### LIFT TRUCK MANUFACTURER'S PLATE

"Designation" Designation	
"Series" Series	
"Year of manufacture" Year of manufacture	
"Model year" Model year	
"Serial Number / Product Identification Number" Serial number / Product Identification Number	
"Unladen mass" Unladen weight	
"Power" Power	
"Authorized gross vehicle weight" Authorized gross vehicle weight	
"Rated capacity" Rated capacity	
"Max vertical force (on trailer hook)" Maximum vertical force (on trailer hook)	
"Drag strain" Drawbar pull	



### ENGINE

"MODEL" Model	
"CODE" Code	
"E1" Identification	
"SERNO" Serial number	
"SPEC" Specification	

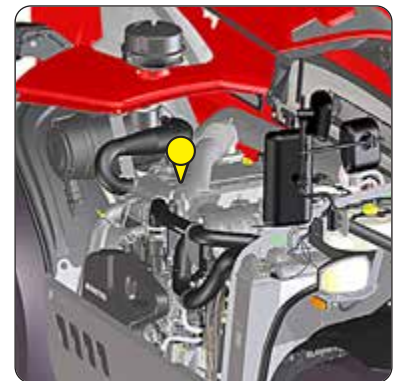

### GEARBOX

Type	
Serial number	
MANITOU Part No.	



### FRONT AXLE

Type	
Serial number	
MANITOU Part No.	



**REAR AXLE**

Type	
Serial number	
MANITOU Part No.	

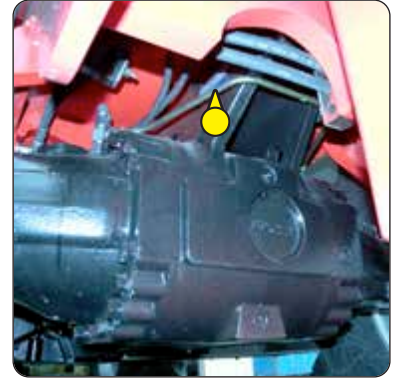

**CAB**

"Constructeur" Manufacturer	
"Type Cabine" Cab type	
"Numéro de série" Serial number	



**BOOM**

MANITOU Part No.	
Date of manufacture and manufacturer	



**CHASSIS**

Serial number / Product Identification Number	
---	--



**ATTACHMENT MANUFACTURER'S PLATE**

"MODELE" Model	
"N° série" Serial number	
"Année Fabrication" Year of manufacture	
"Masse à vide" Unladen weight	
"Centre de gravité" Center of gravity	
"Capacité Nominale" Rated capacity	
"Pression service" Working pressure	



647874-EN-USM3 B102023  
 MLT 841 145 PS+ Y ST5 S1  
 MLT 1041 145 PS+ LY ST5 S1

## SPECIFICATIONS

MLT 841 145 PS+ Y ST5 S1

<b>ENGINE</b>		
Type		YANMAR 4TN107FHT-5SMUF/4TN107FHT-5SMUF
Fuel		Diesel
Number of cylinders		4 in line
Suction		Supercharged
Injection system		Direct
Ignition sequence		1.3.4.2
Displacement	cm <sup>3</sup>	4567
Bore and stroke	mm	107 x 127
Compression ratio		17,5
Nominal speed laden	rpm	2200
Min. rpm unladen	rpm	900
Max. rpm unladen	rpm	2350
Power ISO 3046	hp - kW	141 - 105
Power SAE J 1995	hp - kW	141 - 105
Maximum torque ISO 3046	Nm	602 to 1,500 rpm
Gravimetric efficiency ISO 5011	%	99,9
Type of cooling		Coolant
Fan		Puller

<b>TRANSMISSION</b>		
Gearbox		DANA
- Type		Mechanical
- Shuttle lever		Electro-hydraulic
- Torque converter		ZF SACHS
- Number of forward speeds		5
- Number of reverse speeds		3
Angle gearbox		-
Front axle		DANA
- Differential		Limited slip
Rear axle		DANA
- Differential		Limited slip
Drive wheels		Permanent 4 WD
- 2/4 wheel drive control		No
Front tires		ALLIANCE
- Size		460/70-R24 A580 159A8
- Pressure	bar	4
Rear tires		ALLIANCE
- Size		460/70-R24 A580 159A8
- Pressure	bar	4

<b>ELECTRIC CIRCUIT</b>		
Battery		12 V - 180 Ah - 1200 A EN
Alternator		14 V - 150 A
- Type		BOSCH HD 8
Starter		4,7V - 3,4 kW
- Type		MITSUBISHI

<b>BRAKE SYSTEM</b>		
Service brake		Hydraulic power brake
- Type of brake		Oil-immersed multi-disc brake
- Type of control		Foot-operated for the front and rear axles
Parking brake		Low pressure brake
- Type of brake		Disk on gear-box output
- Type of control		Electro-hydraulic

<b>SOUND AND VIBRATION</b>		
Sound pressure level in the driver's cab LpA (according to standard EN 12053)	dB(A)	69 (cab closed)
Sound pressure (according to Directive 2009/76)	dB(A)	(cab closed); (cab open)
Sound pressure level ensured in the LwA environment (according to Directive 2000/14/EC modified by Directive 2005/88/EC)	dB(A)	104 (measured) ; 105 (guaranteed)
Sound level in motion (according to Directive 2009/63)	dB(A)	
Average weighted acceleration on driver's body (according to standard EN 13059)	m/s <sup>2</sup>	0.8
The average weighted acceleration transmitted to the driver's hand/ arm system (according to standard ISO 5349-2)	m/s <sup>2</sup>	< 2,5
Standard seat vibration	m/s <sup>2</sup>	1,14 (lightweight operator) ; 0,91 (heavyweight operator)

<b>HYDRAULIC CIRCUIT</b>		
Hydraulic pump		
- Type		Variable displacement pump
- Displacement	cm <sup>3</sup>	85
- Max. rating capacity unladen	l/min	200
- Flow rate at 1,600 rpm	l/min	136
Filtration		
- Return	µm	10
- Suction	µm	135
Maximum service pressure		
- Telescoping circuit	bar	200 / 270
- Lifting circuit	bar	270 / 270
- Tilting circuit	bar	270 / 200
- Stabilizer system	bar	-
- Frame leveling circuit	bar	-
- Attachment circuit	bar	270
- Steering circuit	bar	175

<b>HYDRAULIC MOVEMENTS</b>		
Lifting motions (boom retracted)		
- Unladen lifting	s - m/min	6,4 - 47,3
- Laden lifting	s - m/min	6,4 - 47,3
- Unladen lowering	s - m/min	4,6 - 65,9
- Laden lowering	s - m/min	4,6 - 65,9
Telescoping motions (boom raised)		
- Unladen extending	s - m/min	6,1 - 29,3
- Laden extending	s - m/min	6,1 - 29,3
- Unladen retracting	s - m/min	5,2 - 34,3
- Laden retracting	s - m/min	5,2 - 34,3
Tilting movements		
- Unladen crowd	s - °/s	3 - 48,9
- Unladen dump	s - °/s	2,2 - 66,7

<b>SPECIFICATIONS AND WEIGHTS</b>		
Speed of movement for lift truck in standard configuration on flat ground		
- Front unladen	1	km/h
	2	km/h
	3	km/h
	4	km/h
	5	km/h
- Rear unladen	1	km/h
	2	km/h
	3	km/h
Standard attachment		
- Weight with forks	kg	200
- Weight of forks (each)	kg	70
Rated capacity with standard attachment	kg	4100
Tipping load at maximum reach on tires	kg	1450
Distance from the center of gravity of the load to the base of the forks	mm	500
Standard lifting height	mm	7600
Lift truck weight without attachment	kg	8820
Weight of lift truck with standard attachment		
- Unladen	kg	9160
- At rated load	kg	13260
Weight per axle with standard attachment (transport position)		
- Front unladen	kg	3970
- Rear unladen	kg	5190
- Front rated load	kg	11380
- Rear rated load	kg	1880
Weight per axle with standard attachment (boom extended)		
- Front rated load	kg	9610
- Rear rated load	kg	1100
Tractive effort on the coupling hook		
- Unladen (sliding)	daN	5935
- At rated load (transmission setting)	daN	8727
Break-out force with bucket (according to standard ISO 8313)	daN	5268

## SPECIFICATIONS

MLT 1041 145 PS+ L Y ST5 S1

ENGINE		
Type		YANMAR 4TN107FHT-5SMUF
Fuel		Diesel
Number of cylinders		4 in line
Suction		Supercharged
Injection system		Direct
Ignition sequence		1.3.4.2
Displacement	cm <sup>3</sup>	4,567
Bore and stroke	mm	107 x 127
Compression ratio		17.5
Nominal speed laden	rpm	2,200
Min. rpm unladen	rpm	900
Max. rpm unladen	rpm	2,350
Power ISO 3046	hp - kW	141 - 105
Power SAE J 1995	hp - kW	141 - 105
Maximum torque ISO 3046	Nm	602 to 1,500 rpm
Gravimetric efficiency ISO 5011	%	99.9
Type of cooling		Coolant
Fan		Puller

TRANSMISSION		
Gearbox		DANA
- Type		Mechanical
- Shuttle lever		Electro-hydraulic
- Torque converter		ZF SACHS
- Number of forward speeds		5
- Number of reverse speeds		3
Angle gearbox		-
Front axle		DANA
- Differential		Limited slip
Rear axle		DANA
- Differential		Limited slip
Drive wheels		Permanent 4 WD
- 2/4 wheel drive control		No
Front tires		ALLIANCE
- Size		460/70-R24 A580 159A8
- Pressure	bar	4
Rear tires		ALLIANCE
- Size		460/70-R24 A580 159A8
- Pressure	bar	4

ELECTRIC CIRCUIT		
Battery		12 V - 180 Ah - 1200 A EN
Alternator		14 V - 150 A
- Type		BOSCH HD 8
Starter		4,7V - 3,4 kW
- Type		MITSUBISHI

BRAKE SYSTEM		
Service brake		Hydraulic power brake
- Type of brake		Oil-immersed multi-disc brake
- Type of control		Foot-operated for the front and rear axles
Parking brake		Low pressure brake
- Type of brake		Disk on gear-box output
- Type of control		Electro-hydraulic

SOUND AND VIBRATION		
Sound pressure level in the driver's cab LpA (according to standard EN 12053)	dB(A)	69 (cab closed)
Sound pressure (according to Directive 2009/76)	dB(A)	(cab closed); (cab open)
Sound pressure level ensured in the LwA environment (according to Directive 2000/14/EC modified by Directive 2005/88/EC)	dB(A)	104 (measured) ; 105 (guaranteed)
Sound level in motion (according to Directive 2009/63)	dB(A)	
Average weighted acceleration on driver's body (according to standard EN 13059)	m/s <sup>2</sup>	0.8
The average weighted acceleration transmitted to the driver's hand/ arm system (according to standard ISO 5349-2)	m/s <sup>2</sup>	< 2,5
Standard seat vibration	m/s <sup>2</sup>	1,14 (lightweight operator) ; 0,91 (heavyweight operator)

<b>HYDRAULIC CIRCUIT</b>		
Hydraulic pump		
- Type		Variable displacement pump
- Displacement	cm <sup>3</sup>	85
- Max. rating capacity unladen	l/min	200
- Flow rate at 1,600 rpm	l/min	136
Filtration		
- Return	µm	10
- Suction	µm	135
Maximum service pressure		
- Telescoping circuit	bar	200 / 270
- Lifting circuit	bar	270 / 270
- Tilting circuit	bar	270 / 200
- Stabilizer system	bar	-
- Frame leveling circuit	bar	-
- Attachment circuit	bar	270
- Steering circuit	bar	175

<b>HYDRAULIC MOVEMENTS</b>		
Lifting motions (boom retracted)		
- Unladen lifting	s - m/min	6,6 - 44,3
- Laden lifting	s - m/min	6,6 - 44,3
- Unladen lowering	s - m/min	4,7 - 62,2
- Laden lowering	s - m/min	4,7 - 62,2
Telescoping motions (boom raised)		
- Unladen extending	s - m/min	9,5 - 33,1
- Laden extending	s - m/min	9,5 - 33,1
- Unladen retracting	s - m/min	6,9 - 45,6
- Laden retracting	s - m/min	6,9 - 45,6
Tilting movements		
- Unladen crowd	s - °/s	3,7 - 39,7
- Unladen dump	s - °/s	2,8 - 52,4

<b>SPECIFICATIONS AND WEIGHTS</b>		
Speed of movement for lift truck in standard configuration on flat ground		
- Front unladen	1	km/h
	2	km/h
	3	km/h
	4	km/h
	5	km/h
- Rear unladen	1	km/h
	2	km/h
	3	km/h
Standard attachment		
- Weight with forks	kg	200
- Weight of forks (each)	kg	70
Rated capacity with standard attachment		
		kg
		4100
Tipping load at maximum reach on tires		
		kg
		700
Distance from the center of gravity of the load to the base of the forks		
		mm
		500
Standard lifting height		
		mm
		9650
Lift truck weight without attachment		
		kg
		9350
Weight of lift truck with standard attachment		
- Unladen	kg	9690
- At rated load	kg	13790
Weight per axle with standard attachment (transport position)		
- Front unladen	kg	4230
- Rear unladen	kg	5460
- Front rated load	kg	11220
- Rear rated load	kg	2570
Weight per axle with standard attachment (boom extended)		
- Front rated load	kg	9160
- Rear rated load	kg	1230
Tractive effort on the coupling hook		
- Unladen (sliding)	daN	6400
- At rated load (transmission setting)	daN	9130
Break-out force with bucket (according to standard ISO 8313)		
		daN
		5043

## TIRES

MLT 841 145 PS+ Y ST5 S1		PRESSURE (bar)	LOAD PER TIRE (kg)			
			FRONT (UNLADEN)	FRONT (LADEN)	REAR (UNLADEN)	REAR (LADEN)
MICHELIN	460/70-R24 XMCL 159A8	4	2000	5700	2600	950
	500/70-R24 XMCL 164A8	3,4				
	460/70-R24 BIBLOAD 159A8	4				
	500/70-R24 BIBLOAD 164A8	3,4				
ALLIANCE	460/70-R24 A580 159A8	4				
	460/70-R24 A585 159A8	4				
TRELLEBORG	460/70-R24 TH400 159A8	4				
	460/70-R24 TH500 159A8	4				
	500/70-R24 TH400 164A8	3,6				
VREDESTEIN	460/70-R24 ENDURION	4				
	500/70-R24 ENDURION	3,6				

MLT 1041 145 PS+ LY ST5 S1		PRESSURE (bar)	LOAD PER TIRE (kg)			
			FRONT (UNLADEN)	FRONT (LADEN)	REAR (UNLADEN)	REAR (LADEN)
MICHELIN	460/70-R24 XMCL 159A8	4	2100	5600	2750	1300
	500/70-R24 XMCL 164A8	3,4				
	460/70-R24 BIBLOAD 159A8	4				
	500/70-R24 BIBLOAD 164A8	3,4				
ALLIANCE	460/70-R24 A580 159A8	4				
	460/70-R24 A585 159A8	4				
TRELLEBORG	460/70-R24 TH400 159A8	4				
	460/70-R24 TH500 159A8	4				
	500/70-R24 TH400 164A8	3,6				
VREDESTEIN	460/70-R24 ENDURION	4				
	500/70-R24 ENDURION	3,6				

		PRESSURE (bar)	LOAD (kg)	GROUND CONTACT PRESSURE (kg/cm <sup>2</sup> )		GROUND CONTACT AREA (cm <sup>2</sup> )	
				HARD GROUND	SOFT GROUND	HARD GROUND	SOFT GROUND
MICHELIN	460/70-R24 XMCL 159A8	4	950				
			1300				
			2000				
			2100				
			2600				
			2750				
			5600				
			5700				
	500/70-R24 XMCL 164A8	3,4	950				
			1300				
			2000				
			2100				
			2600				
			2750				
			5600				
			5700				
	460/70-R24 BIBLOAD 159A8	4	950				
			1300				
			2000				
			2100				
			2600				
			2750				
			5600				
			5700				
	500/70-R24 BIBLOAD 164A8	3,4	950				
			1300				
			2000				
			2100				
2600							
2750							
5600							
5700							
ALLIANCE	460/70-R24 A580 159A8	4	950				
			1300				
			2000				
			2100				
			2600				
			2750				
			5600				
			5700				
	460/70-R24 A585 159A8	4	950				
			1300				
			2000				
			2100				
			2600				
			2750				
			5600				
			5700				

		PRESSURE (bar)	LOAD (kg)	GROUND CONTACT PRESSURE (kg/cm <sup>2</sup> )		GROUND CONTACT AREA (cm <sup>2</sup> )	
				HARD GROUND	SOFT GROUND	HARD GROUND	SOFT GROUND
TRELLEBORG	460/70-R24 TH400 159A8	4	950				
			1300				
			2000				
			2100				
			2600				
			2750				
			5600				
			5700				
	460/70-R24 TH500 159A8	4	950				
			1300				
			2000				
			2100				
			2600				
			2750				
			5600				
			5700				
	500/70-R24 TH400 164A8	3,6	950				
			1300				
			2000				
			2100				
			2600				
			2750				
			5600				
			5700				
VREDESTEIN	460/70-R24 ENDURION	4	950				
			1300				
			2000				
			2100				
			2600				
			2750				
			5600				
			5700				
	500/70-R24 ENDURION	3,6	950				
			1300				
			2000				
			2100				
			2600				
			2750				
			5600				
			5700				



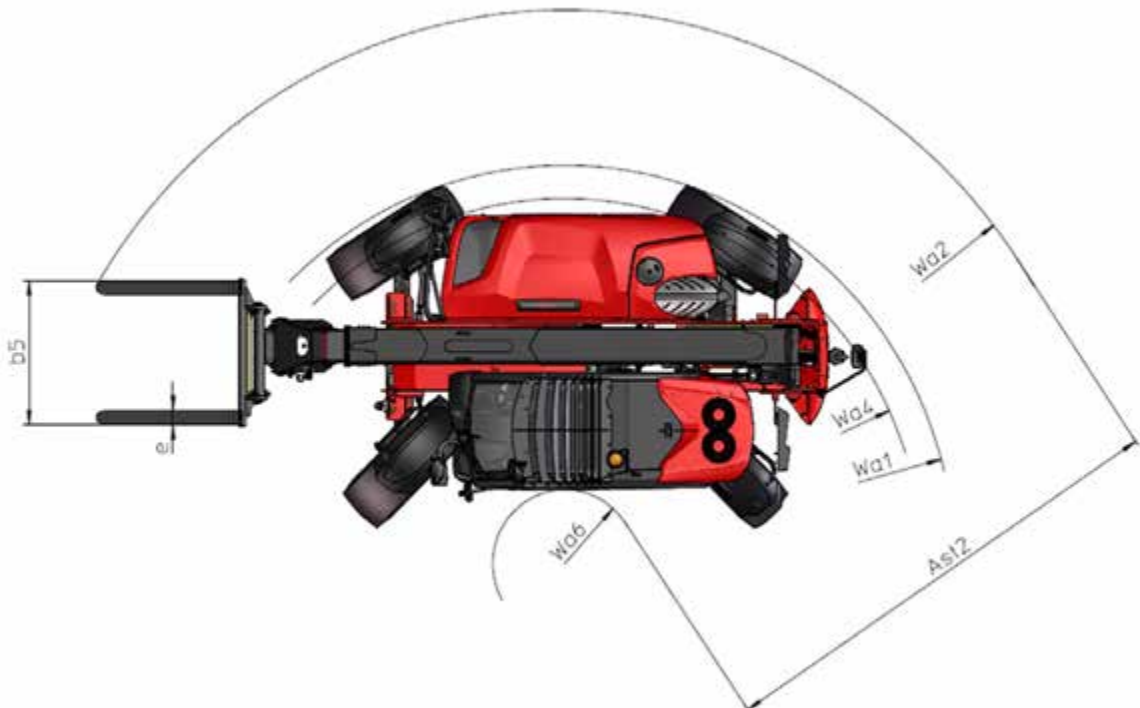
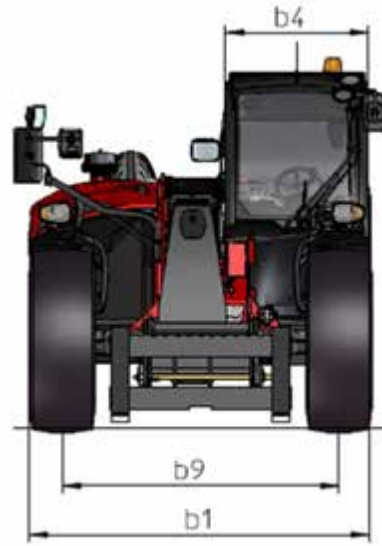
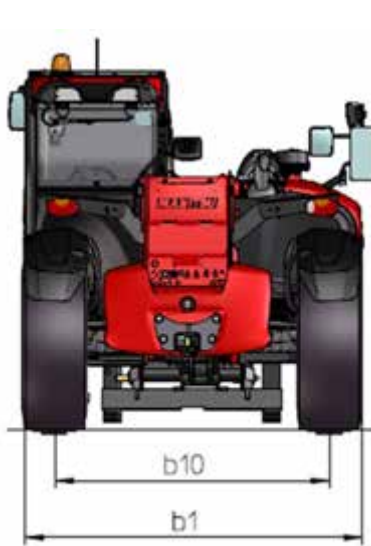
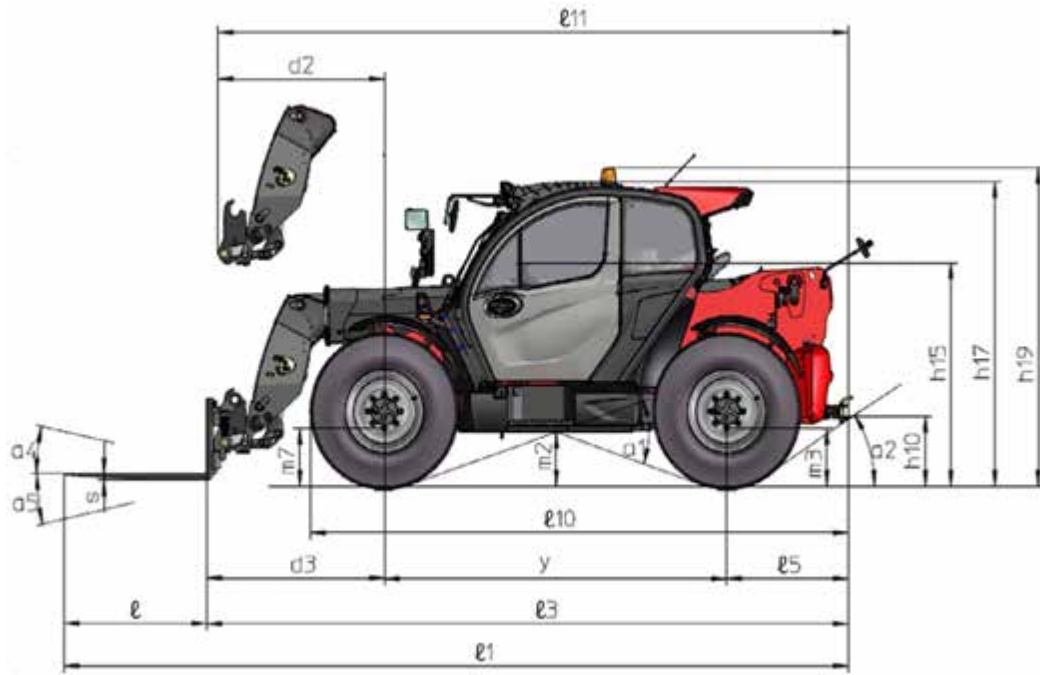

MACHINE LENGTH	<b>ℓ1</b>	mm	6598
	<b>ℓ3</b>	mm	5398
	<b>ℓ5</b>	mm	1023
	<b>ℓ10</b>	mm	4527
	<b>ℓ11</b>	mm	5270
MACHINE WIDTH	<b>b1</b>	mm	2392
	<b>b4</b>	mm	994
	<b>b5</b>	mm	1245
	<b>b9</b>	mm	1925
	<b>b10</b>	mm	1925
MACHINE HEIGHT	<b>h10</b>	mm	557
	<b>h15</b>	mm	1775
	<b>h17</b>	mm	2421
	<b>h19</b>	mm	2532
DISTANCE	<b>d2</b>	mm	1367
	<b>d3</b>	mm	1495
AISLE WIDTH	<b>Ast2</b>	mm	4100
ATTACHMENT	<b>ℓ</b>	mm	1200
	<b>s</b>	mm	50
	<b>e</b>	mm	125
TURNING RADIUS	<b>Wa1</b>	mm	3744
	<b>Wa2</b>	mm	5030
	<b>Wa4</b>	mm	3510
	<b>Wa6</b>	mm	930
GROUND CLEARANCE	<b>m2</b>	mm	430
	<b>m3</b>	mm	457
	<b>m7</b>	mm	457
ANGLE	<b>a1</b>	°	38
	<b>a2</b>	°	33
	<b>a4</b>	°	12
	<b>a5</b>	°	135
	<b>a11</b>	°	-
	<b>a12</b>	°	-
WHEELBASE	<b>y</b>	mm	2880

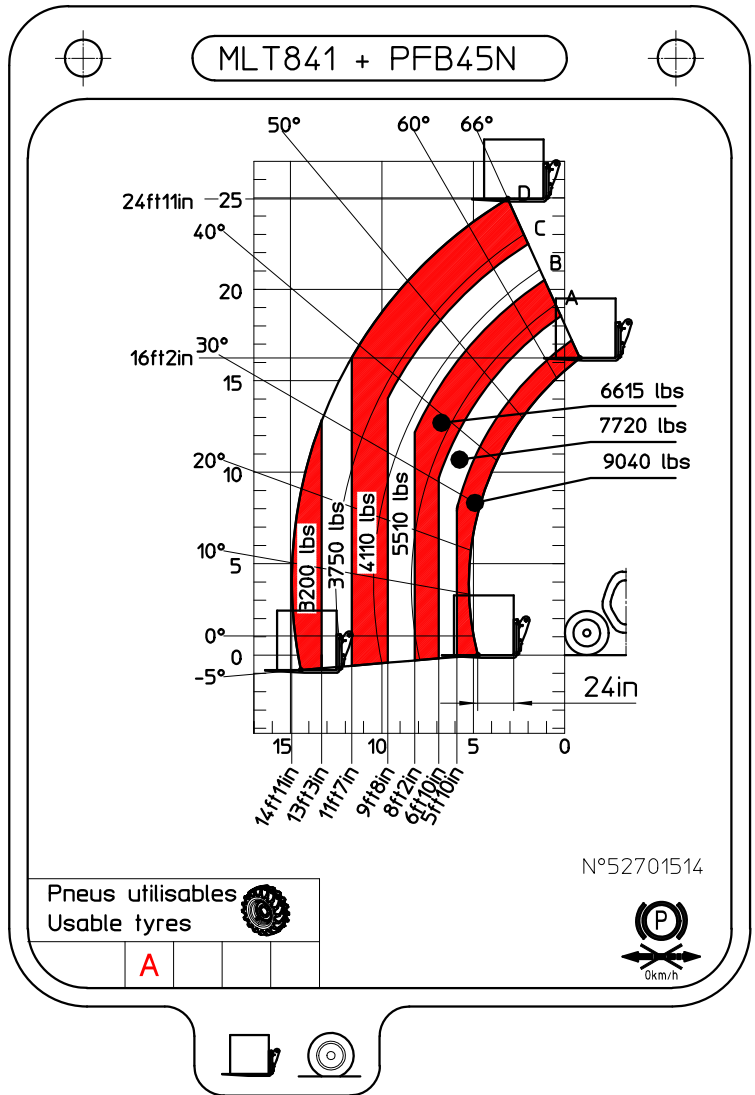

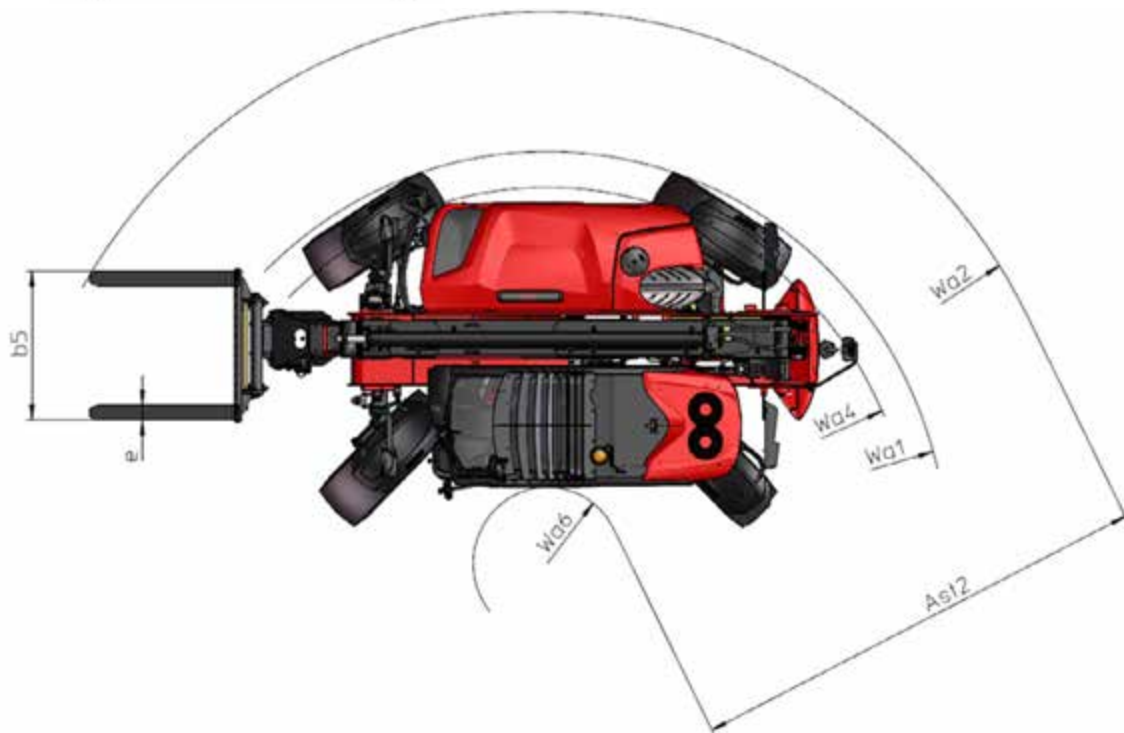
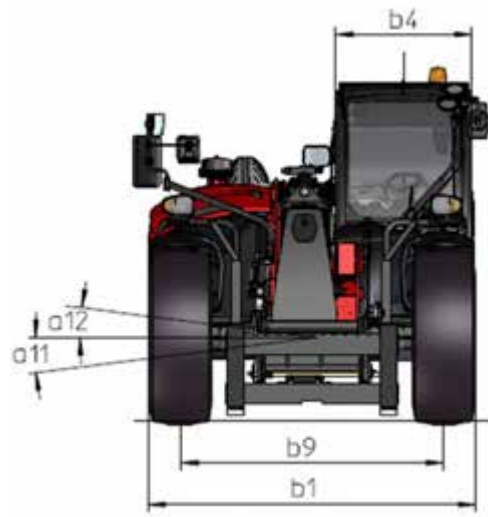
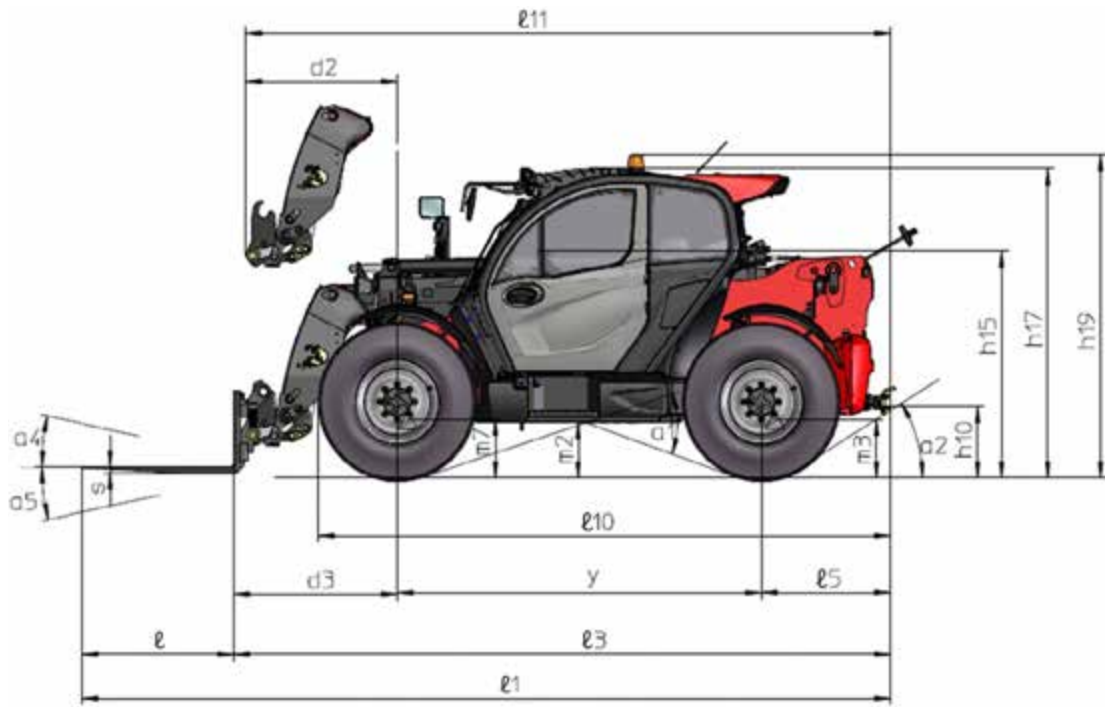

MACHINE LENGTH	<b>ℓ1</b>	mm	6398
	<b>ℓ3</b>	mm	5198
	<b>ℓ5</b>	mm	1023
	<b>ℓ10</b>	mm	4527
	<b>ℓ11</b>	mm	5101
MACHINE WIDTH	<b>b1</b>	mm	2392
	<b>b4</b>	mm	994
	<b>b5</b>	mm	1245
	<b>b9</b>	mm	1925
	<b>b10</b>	mm	1925
MACHINE HEIGHT	<b>h10</b>	mm	557
	<b>h15</b>	mm	1775
	<b>h17</b>	mm	2421
	<b>h19</b>	mm	2532
DISTANCE	<b>d2</b>	mm	1198
AISLE WIDTH	<b>d3</b>	mm	1295
	<b>Ast2</b>	mm	4100
ATTACHMENT	<b>ℓ</b>	mm	1200
	<b>s</b>	mm	50
	<b>e</b>	mm	125
TURNING RADIUS	<b>Wa1</b>	mm	3744
	<b>Wa2</b>	mm	4830
	<b>Wa4</b>	mm	3510
	<b>Wa6</b>	mm	930
GROUND CLEARANCE	<b>m2</b>	mm	430
	<b>m3</b>	mm	457
	<b>m7</b>	mm	457
ANGLE	<b>a1</b>	°	38
	<b>a2</b>	°	33
	<b>a4</b>	°	12
	<b>a5</b>	°	135
	<b>a11</b>	°	7
	<b>a12</b>	°	7
WHEELBASE	<b>y</b>	mm	2880

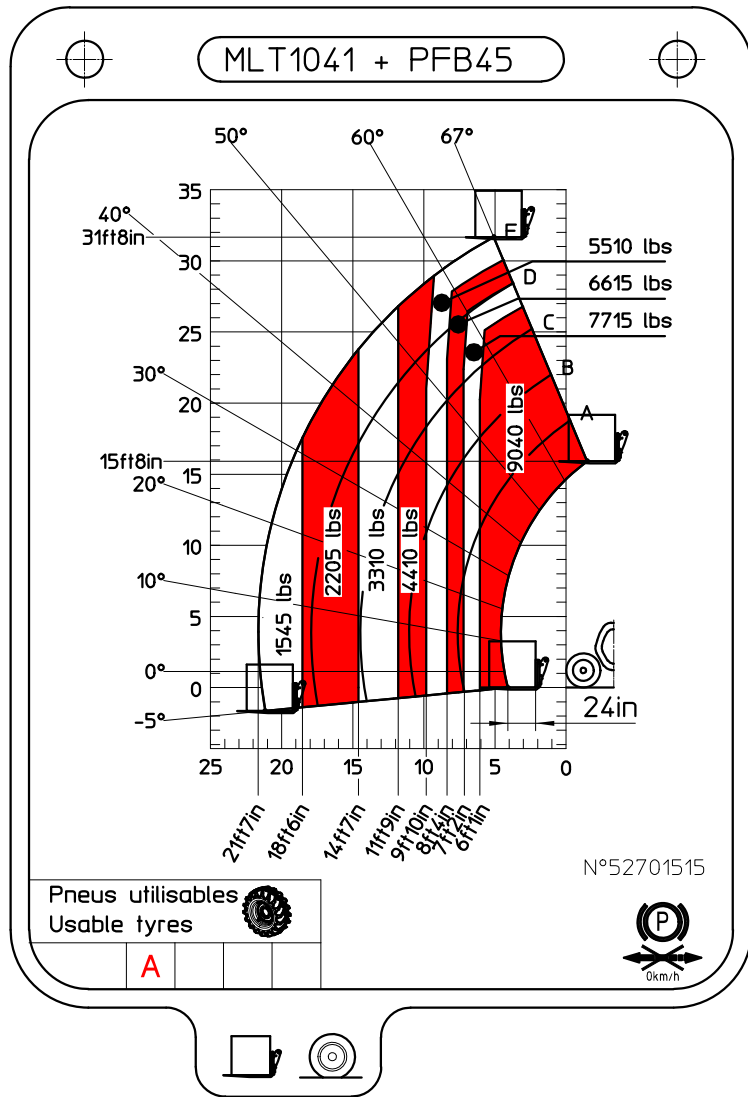

We use European standard EN15830 relating to operator visibility.

- Adhere to the instructions for optimizing operator visibility in the immediate vicinity ( $\leq 1$  - OPERATING AND SAFETY INSTRUCTIONS: OPERATOR INSTRUCTIONS: OPERATING INSTRUCTIONS WITH AND WITHOUT LOAD: D - VISIBILITY).

**DESCRIPTION AND ADJUSTMENT OF REAR-VIEW MIRRORS**

- 1 - LEFT REAR-VIEW MIRROR
- 2 - MAIN RIGHT REAR-VIEW MIRROR
- 3 - SECONDARY RIGHT REAR-VIEW MIRROR (OPTION)
- 4 - RIGHT REAR-VIEW MIRROR (OPTION)
- 5 - INTERNAL REAR-VIEW MIRROR (OPTION)
- 6 - REAR-VIEW MIRROR

- Place the lift truck on level ground with the engine stopped, and the boom retracted and lowered as far as possible.
- Note the position of the reference points ●...○ in the illustrations, to see and correctly adjust the rear-view mirrors.

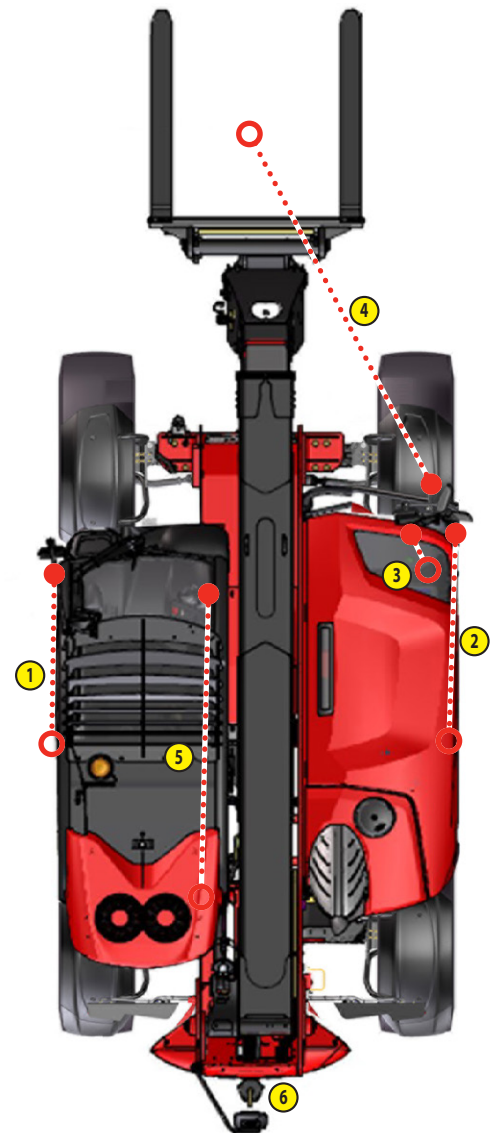
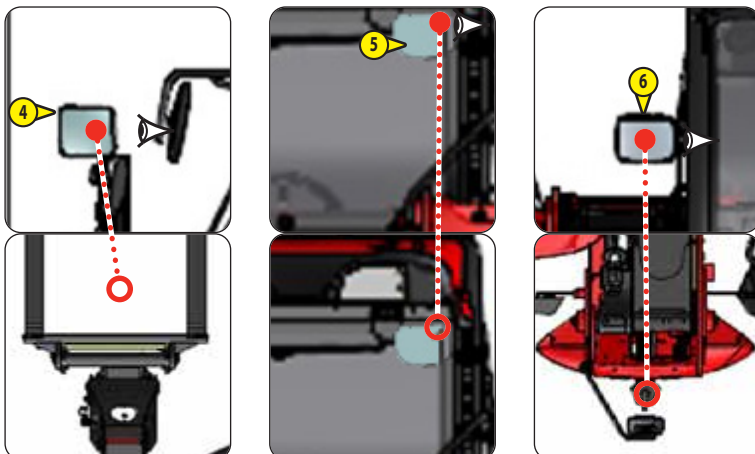
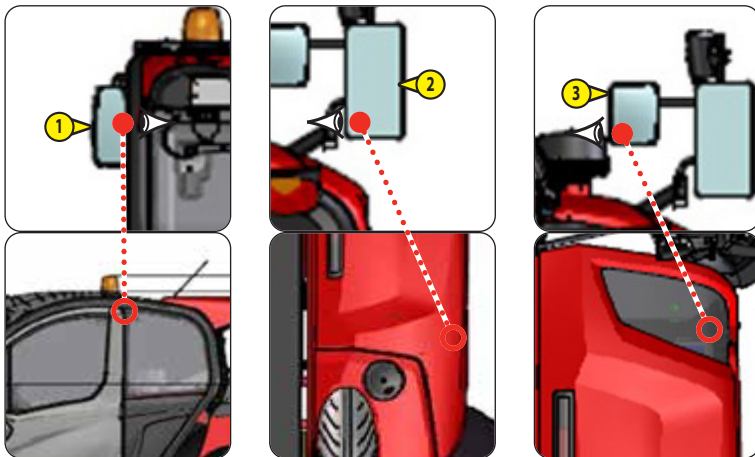
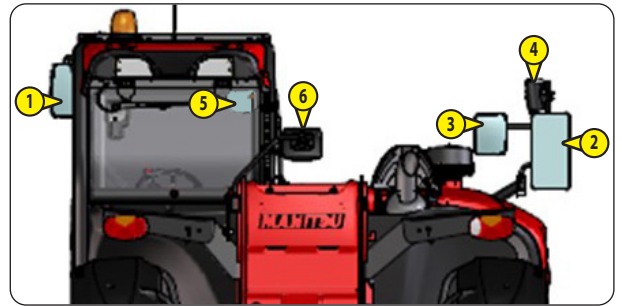

We use European standard EN15830 relating to operator visibility.

- Adhere to the instructions for optimizing operator visibility in the immediate vicinity (<math>\leq 1</math> - OPERATING AND SAFETY INSTRUCTIONS: OPERATOR INSTRUCTIONS: OPERATING INSTRUCTIONS WITH AND WITHOUT LOAD: D - VISIBILITY).

**DESCRIPTION AND ADJUSTMENT OF REAR-VIEW MIRRORS**

- 1 - LEFT REAR-VIEW MIRROR
- 2 - MAIN RIGHT REAR-VIEW MIRROR
- 3 - SECONDARY RIGHT REAR-VIEW MIRROR (OPTION)
- 4 - RIGHT REAR-VIEW MIRROR (OPTION)
- 5 - INTERNAL REAR-VIEW MIRROR (OPTION)
- 6 - REAR-VIEW MIRROR

- Place the lift truck on level ground with the engine stopped, and the boom retracted and lowered as far as possible.
- Note the position of the reference points ●○○ in the illustrations, to see and correctly adjust the rear-view mirrors.

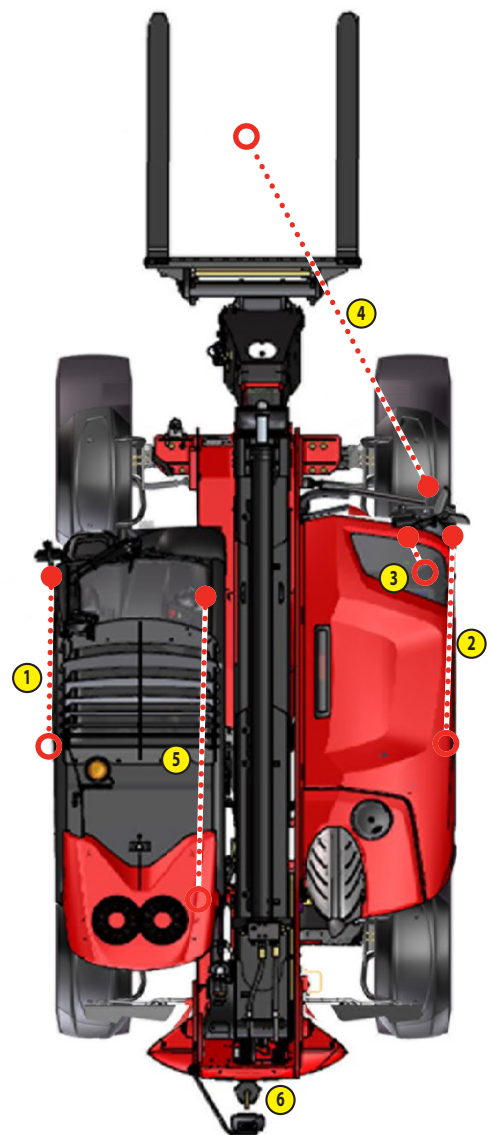
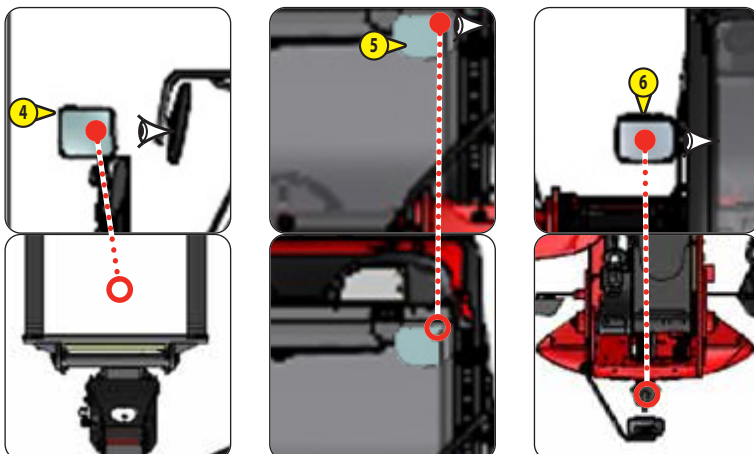
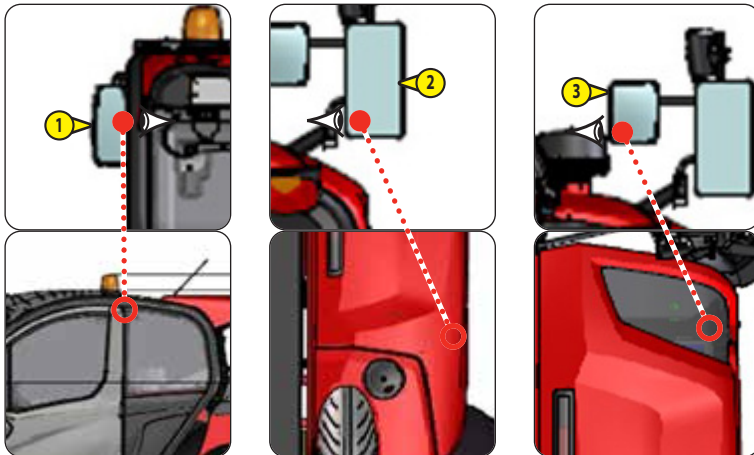
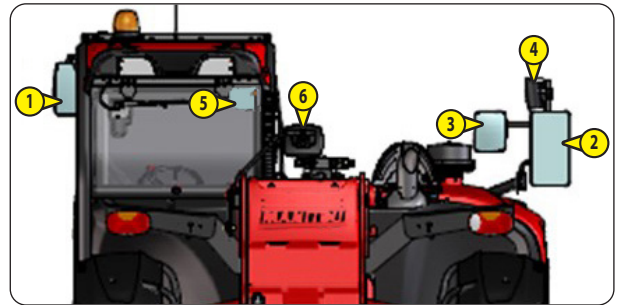

# INSTRUMENTS AND CONTROLS

## DESCRIPTION

NOTE: All the terms such as: RIGHT, LEFT, FRONT, REAR are as seen by an observer occupying the driver's seat and looking straight ahead.

1 - DRIVER'S CAB ACCESS .....	2-26
2 - STEP LIGHTING .....	2-26
3 - DRIVER'S SEAT .....	2-26
4 - ARMREST AND STORAGE .....	2-31
5 - SEAT BELT .....	2-31
6 - BATTERY CUT-OFF .....	2-31
7 - EMERGENCY STOP .....	2-31
8 - IGNITION SWITCH .....	2-31
9 - DASHBOARD "HARMONY" .....	2-32
10 - DASHBOARD "VISION" .....	2-36
11 - ANGULAR SECTOR ON BOOM .....	2-39
12 - INFORMATION SCREEN CONTROL CONSOLE .....	2-40
13 - PUSH BUTTON PANEL .....	2-41
14 - SWITCHES .....	2-43
15 - 12 V SOCKET .....	2-43
16 - DIAGNOSTIC PLUG .....	2-43
17 - USB CHARGING SOCKET .....	2-44
18 - LIGHTING, HORN AND INDICATOR SWITCH .....	2-44
19 - FRONT AND REAR WINDSHIELD WIPER SWITCH .....	2-44
20 - FUSES AND RELAYS IN THE CAB .....	2-45
21 - FUSES AND RELAYS UNDER THE ENGINE HOOD .....	2-47
22 - FORWARD/NEUTRAL/REVERSE GEAR SELECTION .....	2-48
23 - GEAR SELECTOR) .....	2-48
24 - STEERING SELECTION .....	2-49
25 - ACCELERATOR PEDAL .....	2-49
26 - SERVICE BRAKE PEDAL AND TRANSMISSION CUT-OFF .....	2-49
27 - FUNCTION FILES .....	2-49
28 - HYDRAULIC BOOM CONTROLS .....	2-50
29 - LEVEL INDICATOR .....	2-50
30 - HEATER CONTROL .....	2-51
31 - AIR CONDITIONING CONTROLS (AIR CONDITIONING OPTION) .....	2-51
32 - HEATING VENTS .....	2-51
33 - WINDSHIELD DEFROSTER VENTS .....	2-51
34 - WINDOW WINDER .....	2-52
35 - DOOR OPENING AND CLOSING HANDLE .....	2-52
36 - REAR WINDOW STAY .....	2-52
37 - STORAGE NET .....	2-52
38 - STORAGE .....	2-52
39 - CUP HOLDER .....	2-52
40 - FRONT HEADLIGHTS .....	2-52
41 - REAR LIGHTS .....	2-53
42 - ROTATING BEACON LIGHT .....	2-53
43 - SUN VISOR .....	2-53
44 - ROOF LIGHT .....	2-53
45 - HOOK .....	2-53
46 - INTERNAL REAR-VIEW MIRROR .....	2-53
47 - TELEPHONE HOLDER .....	2-53
48 - STEERING WHEEL ADJUSTMENT LEVER .....	2-54
49 - EMERGENCY HAMMER .....	2-54
50 - BOOM SAFETY WEDGE .....	2-54
51 - BUTTON FOR OPENING THE TANK FILLER ACCESS PANEL .....	2-54
52 - FUEL TANK .....	2-55
53 - "DEF" (Diesel Exhaust Fluid) TANK .....	2-55

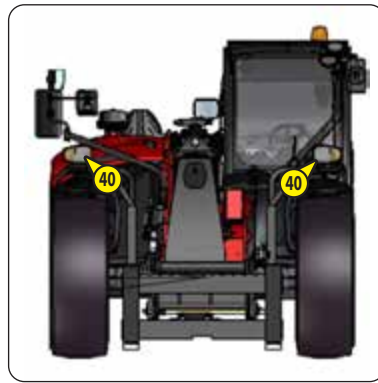
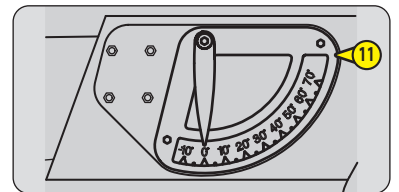
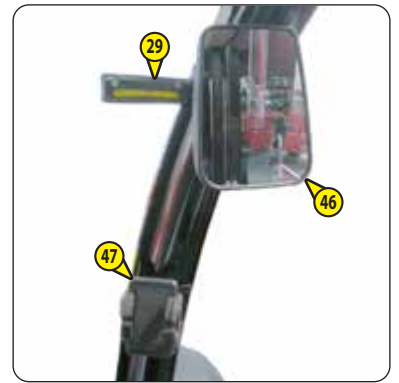
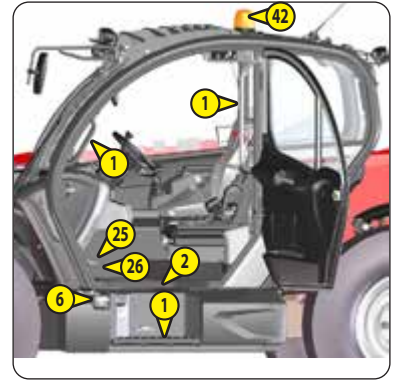
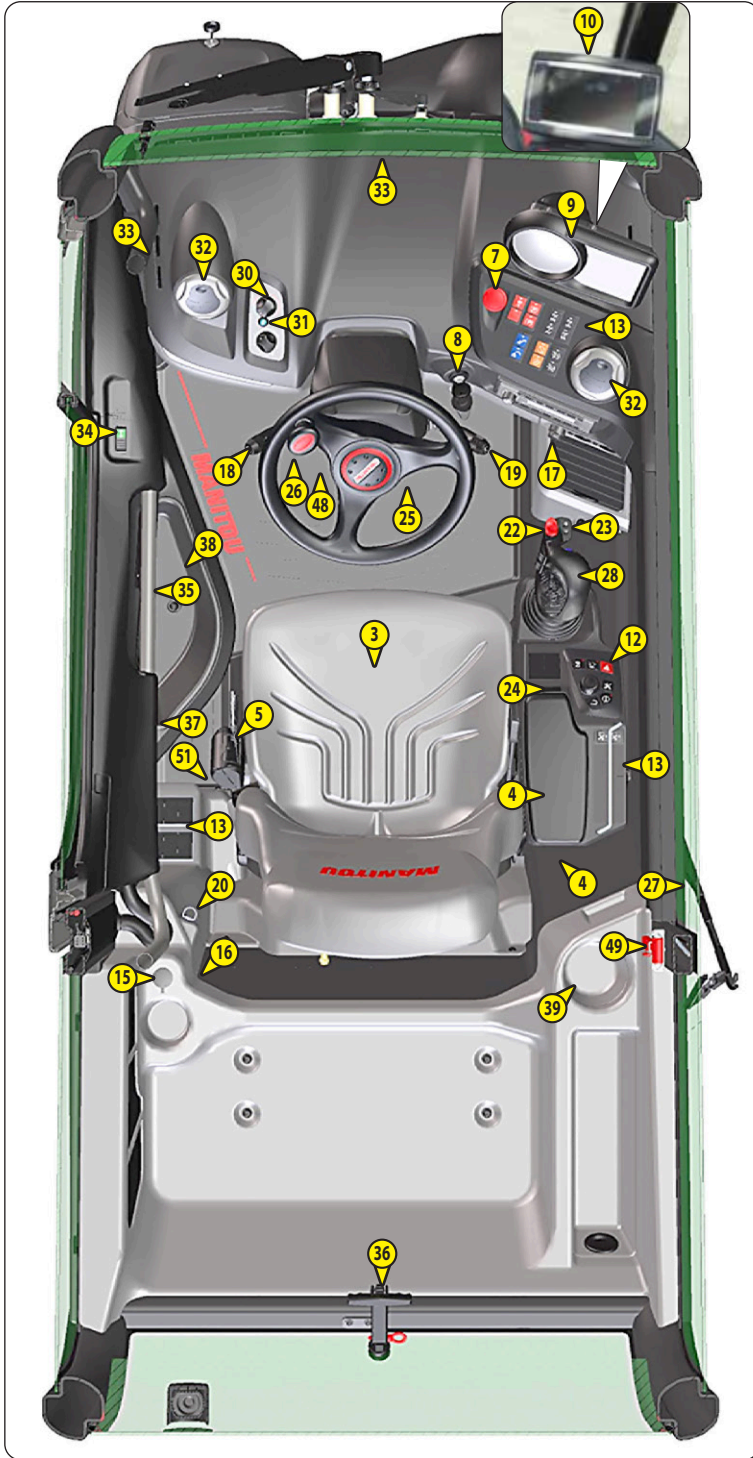

647874-EN-USM3 B102023  
MLT 841 145 PS+ Y ST5 S1  
MLT 1041 145 PS+ LY ST5 S1

## 1 - DRIVER'S CAB ACCESS

- Face the driver's cab access to get in and out, and always use the three support points provided for this purpose.
- 1 - Left handle.
- 2 - Right handle.
- 3 - Step.



## 2 - STEP LIGHTING



## 3 - DRIVER'S SEAT

For increased comfort, adjust the seat to your requirements and adopt the correct position in the driver's cab.

### ⚠ IMPORTANT ⚠

*Under no circumstances must the seat be adjusted while the lift truck is moving.*

### MAINTENANCE

### ⚠ IMPORTANT ⚠

*A moving backrest increases the risk of an accident!*

Dirt may adversely affect the correct operation of the seat. For this reason, make sure your seat is always clean.

- To clean or change the cushions, simply remove them from the seat frame.
- Avoid wetting the cushion fabric when cleaning it. Firstly check the resistance of the fabric on a small hidden area before using any fabric or plastic cleaner.

### DRIVER'S SEAT "CLASSIC"

DESIGNED FOR MAXIMUM COMFORT, THIS SEAT CAN BE ADJUSTED AS FOLLOWS.

#### WEIGHT ADJUSTMENT

It is advised that the weight be adjusted when the driver is not sitting in the cab.

- Refer to graduation 1 of the seat.
- Turn handle 2 according to the driver's weight.

NOTE: To avoid health problems, it is recommended that the weight adjustment should be checked and adjusted before starting the lift truck.

#### HEADREST

- The height of the headrest 3 can be adjusted by pulling it upwards (the notches will click) up to the stop.
- The headrest can be removed by applying sufficient pressure to pull it off the stop.

#### BACKREST ANGLE ADJUSTMENT

### ⚠ IMPORTANT ⚠

*If you do not support the backrest when making adjustments, it swings completely forward.*

- Support the backrest, pull the lever 4 and tilt the backrest to the desired position.

#### LONGITUDINAL ADJUSTMENT

- Engage the locking lever 5 in the desired position. This then locks, preventing the seat from being moved into another position.



## PNEUMATIC DRIVER'S SEAT "PREMIUM"

DESIGNED FOR MAXIMUM COMFORT, THIS SEAT CAN BE ADJUSTED AS FOLLOWS.

### **WEIGHT AND SEAT HEIGHT ADJUSTMENT**

#### **WEIGHT ADJUSTMENT**

Adjust the seat according to your weight while correctly seated.

- Switch on lift truck ignition.
- Push or pull lever 1 until green appears in display 2 indicating correct adjustment according to your weight.

NOTE: To avoid health problems, it is recommended that the weight adjustment should be checked and adjusted before starting the lift truck.

#### **SEAT HEIGHT ADJUSTMENT**

#### **⚠ IMPORTANT ⚠**

*To avoid damage, do not operate the compressor for more than 1 minute.*

When weight adjustment has been carried out, you can then modify seat height.

- Keep the ignition on in the lift truck.
- Push or pull lever 1 until green appears and adjust the height of the seat while checking that the green in display 2 remains visible.

#### **HEADREST**

- The height of the headrest 3 can be adjusted by pulling it upwards (the notches will click) up to the stop.
- The headrest can be removed by applying sufficient pressure to pull it off the stop.

#### **BACKREST ANGLE ADJUSTMENT**

#### **⚠ IMPORTANT ⚠**

*If you do not support the backrest when making adjustments, it swings completely forward.*

- Support the backrest, pull the lever 4 and tilt the backrest to the desired position.

#### **LONGITUDINAL ADJUSTMENT**

- Engage the locking lever 5 in the desired position. This then locks, preventing the seat from being moved into another position.

#### **ARMREST ADJUSTMENT**

- Tip the armrest backwards or adjust its height.
- Remove cap 6 to adjust the height.
- Undo the nut, adjust the height of the armrest and do the nut back up.
- Refit the cap 6.
- You can modify the tilt of the armrest by turning the knob 7.



## PNEUMATIC DRIVER'S SEAT "ÉLITE"

DESIGNED FOR MAXIMUM COMFORT, THIS SEAT CAN BE ADJUSTED AS FOLLOWS.

### WEIGHT AND SEAT HEIGHT ADJUSTMENT

#### **⚠ IMPORTANT ⚠**

*To avoid damage, do not operate the compressor for more than 1 minute.*

#### WEIGHT ADJUSTMENT

Adjust the seat according to your weight while correctly seated.

- Switch on lift truck ignition.
- Briefly pull up lever 1 to automatically adjust the seat according to your weight.

NOTE: To avoid health problems, it is recommended that the weight adjustment should be checked and adjusted before starting the lift truck.

#### SEAT HEIGHT ADJUSTMENT

- Fully push in or pull out lever 1 to adjust the height of the seat. When the upper or lower end stop is reached, the seat automatically adjusts itself, thus minimizing the damping stroke.

### HORIZONTAL SHOCK ABSORBER

In certain conditions (e.g. driving with a trailer) it is advised the horizontal shock absorber 2 be used. The driver's seat is thus better able to absorb jerks in the direction of travel.

- Position A: Horizontal shock absorber removed.
- Position B: Horizontal shock absorber fitted.

### HEADREST

- The height of the headrest 3 can be adjusted by pulling it upwards (the notches will click) up to the stop.
- The headrest can be removed by applying sufficient pressure to pull it off the stop.

### BACKREST ANGLE ADJUSTMENT

#### **⚠ IMPORTANT ⚠**

*If you do not support the backrest when making adjustments, it swings completely forward.*

- Support the backrest, pull the lever 4 and tilt the backrest to the desired position.

### LONGITUDINAL ADJUSTMENT

- Engage the locking lever 5 in the desired position. This then locks, preventing the seat from being moved into another position.

### LUMBAR ADJUSTMENT

This increases the comfort of the seat and the driver's freedom of movement.

- Turn the handle 6 either left or right to adjust the height or depth of the lumbar support.

### ARMREST ADJUSTMENT

- Tip the armrest backwards or adjust its height.
- Remove cap 7 to adjust the height.
- Undo the nut, adjust the height of the armrest and do the nut back up.
- Refit the cap 7.
- You can modify the tilt of the armrest by turning the knob 8.



## PNEUMATIC DRIVER'S SEAT "LUXE"

DESIGNED FOR MAXIMUM COMFORT, THIS SEAT CAN BE ADJUSTED AS FOLLOWS.

### WEIGHT AND SEAT HEIGHT ADJUSTMENT

#### **⚠ IMPORTANT ⚠**

*To avoid damage, do not operate the compressor for more than 1 minute.*

#### WEIGHT ADJUSTMENT

Adjust the seat according to your weight while correctly seated.

- Switch on lift truck ignition.
- Briefly pull up lever 1 to automatically adjust the seat according to your weight.

NOTE: To avoid health problems, it is recommended that the weight adjustment should be checked and adjusted before starting the lift truck.

#### SEAT HEIGHT ADJUSTMENT

- Fully push in or pull out lever 1 to adjust the height of the seat. When the upper or lower end stop is reached, the seat automatically adjusts itself, thus minimizing the damping stroke.

### HORIZONTAL SHOCK ABSORBER

In certain conditions (e.g. driving with a trailer) it is advised the horizontal shock absorber 2 be used. The driver's seat is thus better able to absorb jerks in the direction of travel.

- Position A: Horizontal shock absorber removed.
- Position B: Horizontal shock absorber fitted.

### HEADREST

- The height of the headrest 3 can be adjusted by pulling it upwards (the notches will click) up to the stop.
- The headrest can be removed by applying sufficient pressure to pull it off the stop.

### BACKREST ANGLE ADJUSTMENT

#### **⚠ IMPORTANT ⚠**

*If you do not support the backrest when making adjustments, it swings completely forward.*

- Support the backrest, pull the lever 4 and tilt the backrest to the desired position.

### LONGITUDINAL ADJUSTMENT

- Engage the locking lever 5 in the desired position. This then locks, preventing the seat from being moved into another position.

### LUMBAR ADJUSTMENT

This increases the comfort of the seat and the driver's freedom of movement.

- The lumbar support in the upper or lower part of the backrest can be separately adjusted by operating the upper or lower switch.
- The curvature of the lumbar adjustment setting is adjusted by pressing "+" or "-" on the corresponding switch 6.
- Release the switch when the desired backrest curvature is achieved.

### ARMREST ADJUSTMENT

- Tip the armrest backwards or adjust its height.
- Remove cap 7 to adjust the height.
- Undo the nut, adjust the height of the armrest and do the nut back up.
- Refit the cap 7.
- You can modify the tilt of the armrest by turning the knob 8.

### HEATING

- Operate switch 9 to enable or disable the seat heating function.



## PNEUMATIC DRIVER'S SEAT "ALDDS"

DESIGNED FOR MAXIMUM COMFORT, THIS SEAT CAN BE ADJUSTED AS FOLLOWS.

### SEAT ADJUSTMENT

#### **⚠ IMPORTANT ⚠**

*To avoid damage, do not operate the compressor for more than 1 minute.*

#### WEIGHT ADJUSTMENT

Adjust the seat according to your weight while correctly seated.

- Turn on the ignition with the ignition key.
- Briefly pull up lever 1 to automatically adjust the seat according to your weight.

NOTE: To avoid health problems, it is recommended that the weight adjustment should be checked and adjusted before starting the lift truck.

#### SEAT HEIGHT ADJUSTMENT

- Fully push in or pull out lever 1 to adjust the height of the seat. When the upper or lower end stop is reached, the seat automatically adjusts itself, thus minimizing the damping stroke.

#### SEAT TILT ADJUSTMENT

- Pull the handle 2 upward while increasing or reducing the pressure on the front or back of the seat to find a comfortable position.

#### SEAT DEPTH ADJUSTMENT

- Pull the handle 3 upward while moving the seat backward or forward to find the desired position.

### HORIZONTAL SHOCK ABSORBER

In certain conditions (e.g. driving with a trailer) it is advised the horizontal shock absorber 4 be used. The driver's seat is thus better able to absorb jerks in the direction of travel.

- Position A: Horizontal shock absorber ACTIVATED.
- Position B: Horizontal shock absorber DEACTIVATED.

### HEADREST

- The height of the headrest 5 can be adjusted by pulling it upwards (the notches will click) up to the stop.
- The headrest can be removed by applying sufficient pressure to pull it off the stop.

### BACKREST ANGLE ADJUSTMENT

#### **⚠ IMPORTANT ⚠**

*If you do not support the backrest when making adjustments, it swings completely forward.*

- Support the backrest, pull the lever 6 and tilt the backrest to the desired position.

### LONGITUDINAL ADJUSTMENT

- Engage the locking lever 7 in the desired position. This then locks, preventing the seat from being moved into another position.

### LUMBAR ADJUSTMENT

This increases the comfort of the seat and the driver's freedom of movement.

- The lumbar support in the upper or lower part of the backrest can be separately adjusted by operating the upper or lower switch.
- The curvature of the lumbar adjustment setting is adjusted by pressing "+" or "-" on the corresponding switch 8.
- Release the switch when the desired backrest curvature is achieved.

### ARMREST ADJUSTMENT

- Tip the armrest backwards or adjust its height.
- Remove cap 9 to adjust the height.
- Undo the nut, adjust the height of the armrest and do the nut back up.
- Refit the cap 9.
- You can modify the tilt of the armrest by turning the knob 10.

### HEATING

- Operate switch 11 to enable or disable the seat heating function



## 4 - ARMREST AND STORAGE

Lift the armrest to access the storage.

### ARMREST ADJUSTMENT

The armrest adjustment positions the controller.

#### ⚠ IMPORTANT ⚠

*Make sure that the armrest's position is as ergonomic as possible to improve comfortable operation or handling hydraulics.*

- Adjust the height of the armrest with knob A.
- Adjust the armrest forward or backward using knobs B.



## 5 - SEAT BELT

#### ⚠ IMPORTANT ⚠

*Under no circumstances must the lift truck be used if the seat belt is defective (fixing, locking, cuts, tears, etc.). Immediately repair or replace the seat belt.*

- Sit correctly on the seat.
- Check that the seat belt is not twisted.
- Place the seat belt at hip level.
- Attach the seat belt and check that it locks.
- Adjust the seat belt to your body shape without compressing your pelvis and without excessive slack.



## 6 - BATTERY CUT-OFF

For quickly disconnecting the battery when working on the electric circuit or when soldering, for example.

#### ⚠ IMPORTANT ⚠

*Switch off the ignition with the key, wait 30 seconds, then operate the battery cut-off.*

*Wait 5 minutes before disconnecting the battery, this is required in order to purge the Diesel Exhaust Fluid (DEF) system.*



## 7 - EMERGENCY STOP

In case of danger, forces the transmission to neutral and cuts-off hydraulic movements.

#### ⚠ IMPORTANT ⚠

*Be ready for hydraulic movements suddenly stopping when you press this button.*

*If possible stop the lift truck before using the emergency stop button.*

- Turn switch to disable.



## 8 - IGNITION SWITCH

This key switch has 5 positions:

- P - Not used.
- O - Ignition electrical cut-off and engine stop.
- I - Ignition + preheat.
- II - Not used.
- III - Start-up and return to I position as soon as the key is released.



## 9 - DASHBOARD "HARMONY"

### INSTRUMENTS AND INDICATORS

#### A - TACHOMETER

#### B - ENGINE COOLANT TEMPERATURE

If the indicator light  comes on when the lift truck is running, this means that the coolant temperature is high. Leave the engine idling to lower the water temperature. If the fault persists, turn the engine off and investigate the cooling circuit for the cause of the malfunction.

#### C - FUEL LEVEL

Indicator lamp , indicates that you are in reserve and that your running time is limited.

#### D - "DEF" (Diesel Exhaust Fluid) LEVEL

The indicator lamp  lights if the level is below 15%.

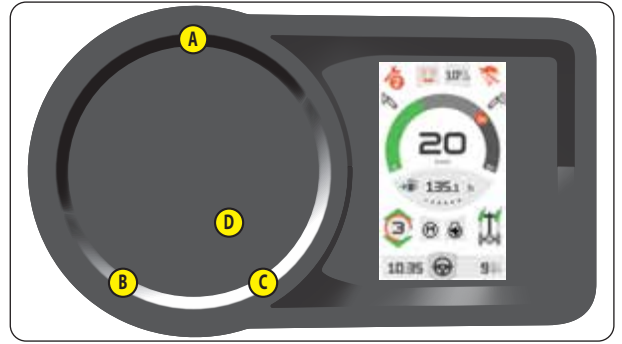

#### BATTERY CHARGE FAULT INDICATOR

If the indicator and the buzzer come on when the lift truck is running, stop the engine immediately and determine the cause (electric circuit, alternator belt, alternator, etc.).

#### STEERING SYSTEM OIL PRESSURE FAULT INDICATOR

If the indicator comes on when the lift truck is running, stop the engine immediately and determine the cause (possible leak, etc.).

#### WATER IN FUEL PRE-FILTER FAULT INDICATOR

The indicator light will come on when water is detected in the fuel pre-filter. Stop the lift truck and carry out the necessary repairs.

#### BRAKING OIL LEVEL WARNING INDICATOR LAMP

If the indicator light and buzzer come on when the lift truck is running, stop the engine immediately and determine the cause (brake fluid level, possible leak, etc.). If the brake fluid level is abnormal, consult your dealer.

#### ENGINE OIL PRESSURE FAULT INDICATOR

If the indicator light comes on when the lift truck is in operation, stop the engine immediately and look for the cause (oil level in engine crankcase).

NOTE: After starting the engine, the indicator light remains on for a few seconds then goes out when the correct engine oil pressure is reached. The full engine power is then available.

#### ENGINE PREHEATING INDICATOR

Preheat is necessary. When the lift truck is switched on, the indicator lamp comes on for 2 seconds and goes off as soon as preheat is ended. Start the lift truck's engine.

#### GEARBOX OIL PRESSURE FAULT INDICATOR

The indicator lamp and buzzer come on when there is an abnormal drop in gearbox pressure, in forward gear. Stop the engine and determine the cause (gearbox oil level, possible leak, radiator, etc.).

NOTE: This indicator lamp operates in forward travel conditions only, and can be ignored when the lift truck is stopped with the engine running at min rpm.



### GEARBOX OIL TEMPERATURE FAULT INDICATOR

The indicator and buzzer come on when the gearbox oil temperature is abnormally high. Stop the engine and determine the cause (gearbox oil level, possible leak, radiator, etc.).



### HYDRAULIC RETURN FILTER CLOGGING FAULT INDICATOR

The indicator light and buzzer come on when the hydraulic return oil filter cartridge is clogged. Stop the engine and carry out the necessary repairs (↩ 3 - MAINTENANCE: FILTER CARTRIDGES AND BELTS).



### ENGINE COOLANT LEVEL FAULT INDICATOR

If the indicator light and buzzer come on when the lift truck is in operation, stop the engine immediately and determine the cause (coolant level, possible leak, radiator, etc.).



### ENGINE STOPPED FAULT INDICATOR

If the indicator lights up or flashes when the lift truck is in operation, stop the engine immediately and consult your dealer.



### AIR FILTER CLOGGING FAULT INDICATOR

The light and the buzzer come on when the air filter cartridge is clogged. Stop the engine and carry out the necessary repairs (↩ 3 - MAINTENANCE: FILTER CARTRIDGES AND BELTS).







### ENGINE FAULT INDICATOR

If the indicator light comes on or flashes while the lift truck is in operation, a diagnostic fault has been detected. The lift truck will operate in reduced mode. Consult your dealer as soon as possible.



### FAULT INDICATOR "SCR" (selective catalytic reduction)

The indicator comes on if the system is above the efficiency threshold or if a diesel exhaust fluid quality problem is detected.

Flashing  indicator light +  + audible signal	- "DEF" (diesel exhaust fluid) level below 10%.
 +  + audible signal	- Consult your dealer as soon as possible.



### CRYSTALLIZATION OR SULFURIZATION LEVEL INDICATOR

If the indicator lamp flashes while the lift truck is running, perform a "STATIONARY LIFT TRUCK" EXHAUST REGENERATION (↩ 3 - MAINTENANCE: OCCASIONAL MAINTENANCE).

**INFORMATION SCREEN**

 **HIGH BEAM HEADLIGHTS INDICATOR**

 **LOW BEAM HEADLIGHTS INDICATOR**

 **TURN SIGNAL INDICATOR**

 **PARKING BRAKE LAMP**

 **BEACON INDICATOR**

 **MAINTENANCE REQUIRED**

 **MAINTENANCE OVERDUE**

 **MAINTENANCE OVERDUE + NUMBER OF ERROR CODES**

 **BOOM ANGLE**

 **HYDRAULIC MOVEMENT NEUTRALIZATION**

 **NOT USED**

 **NOT USED**

 **GEAR RATIO**

 **MANUAL TRANSMISSION**

 **AUTOMATIC TRANSMISSION**

 **WHEEL STEERING INDICATOR**

 **CLOCK**

 **DRIVING MODE**

 **WORK MODE**

 **EXTERNAL TEMPERATURE**





### HOUR METER

- This screen is displayed for a few seconds when the ignition is switched on.



### SPEEDOMETER

- This screen is displayed in driving mode.



### HYDRAULIC FLOW RATE ADJUSTMENT

- This screen is displayed in work mode.

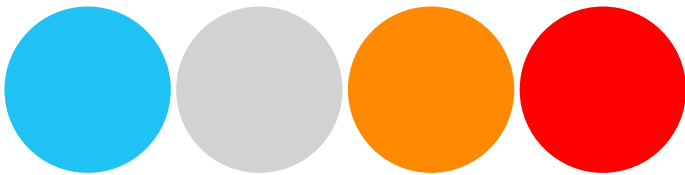

### POP UP

- Blue POP UP: information message.
- Grey POP UP: operating message.
- Orange POP UP: warning message.
- Red POP UP: fault warning message, consult your dealer.



### INFORMATION SCREEN

- Hold down and turn the navigation knob A to change the mode.

- Total hour meter.
- Partial hour meter.
- Instantaneous fuel consumption.
- Average fuel consumption.
- Fuel autonomy.
- Tachometer.



## 10 - DASHBOARD "VISION"

### INSTRUMENTS AND INDICATORS

#### A - TACHOMETER

#### B - ENGINE COOLANT TEMPERATURE



If the indicator light  comes on when the lift truck is running, this means that the coolant temperature is high. Leave the engine idling to lower the water temperature. If the fault persists, turn the engine off and investigate the cooling circuit for the cause of the malfunction.

#### C - FUEL LEVEL





Indicator lamp , indicates that you are in reserve and that your running time is limited.

#### D - "DEF" (Diesel Exhaust Fluid) LEVEL



The indicator lamp  lights if the level is below 15%.

#### E - FAULT WARNING LAMP DISPLAY ZONE

A maximum of five indicator lamps are displayed in the display zone. A red arrow  indicates a sixth fault. Beyond six faults, the  arrow flashes.



#### BATTERY CHARGE FAULT INDICATOR

If the indicator and the buzzer come on when the lift truck is running, stop the engine immediately and determine the cause (electric circuit, alternator belt, alternator, etc.).



#### STEERING SYSTEM OIL PRESSURE FAULT INDICATOR

If the indicator comes on when the lift truck is running, stop the engine immediately and determine the cause (possible leak, etc.).



#### WATER IN FUEL PRE-FILTER FAULT INDICATOR

The indicator light will come on when water is detected in the fuel pre-filter. Stop the lift truck and carry out the necessary repairs.



#### BRAKING OIL LEVEL WARNING INDICATOR LAMP

If the indicator light and buzzer come on when the lift truck is running, stop the engine immediately and determine the cause (brake fluid level, possible leak, etc.). If the brake fluid level is abnormal, consult your dealer.



#### ENGINE OIL PRESSURE FAULT INDICATOR

If the indicator light comes on when the lift truck is in operation, stop the engine immediately and look for the cause (oil level in engine crankcase).

NOTE: After starting the engine, the indicator light remains on for a few seconds then goes out when the correct engine oil pressure is reached. The full engine power is then available.



#### ENGINE PREHEATING INDICATOR

Preheat is necessary. When the lift truck is switched on, the indicator lamp comes on for 2 seconds and goes off as soon as preheat is ended. Start the lift truck's engine.





### GEARBOX OIL PRESSURE FAULT INDICATOR

The indicator lamp and buzzer come on when there is an abnormal drop in gearbox pressure, in forward gear. Stop the engine and determine the cause (gearbox oil level, possible leak, radiator, etc.).

NOTE: This indicator lamp operates in forward travel conditions only, and can be ignored when the lift truck is stopped with the engine running at min rpm.



### GEARBOX OIL TEMPERATURE FAULT INDICATOR

The indicator and buzzer come on when the gearbox oil temperature is abnormally high. Stop the engine and determine the cause (gearbox oil level, possible leak, radiator, etc.).



### HYDRAULIC RETURN FILTER CLOGGING FAULT INDICATOR

The indicator light and buzzer come on when the hydraulic return oil filter cartridge is clogged. Stop the engine and carry out the necessary repairs (<math>\leq 3</math> - MAINTENANCE: FILTER CARTRIDGES AND BELTS).



### ENGINE COOLANT LEVEL FAULT INDICATOR

If the indicator light and buzzer come on when the lift truck is in operation, stop the engine immediately and determine the cause (coolant level, possible leak, radiator, etc.).



### ENGINE STOPPED FAULT INDICATOR

If the indicator lights up or flashes when the lift truck is in operation, stop the engine immediately and consult your dealer.



### AIR FILTER CLOGGING FAULT INDICATOR

The light and the buzzer come on when the air filter cartridge is clogged. Stop the engine and carry out the necessary repairs (<math>\leq 3</math> - MAINTENANCE: FILTER CARTRIDGES AND BELTS).







### ENGINE FAULT INDICATOR

If the indicator light comes on or flashes while the lift truck is in operation, a diagnostic fault has been detected. The lift truck will operate in reduced mode. Consult your dealer as soon as possible.



### FAULT INDICATOR "SCR" (selective catalytic reduction)

The indicator comes on if the system is above the efficiency threshold or if a diesel exhaust fluid quality problem is detected.

Flashing  indicator light +  + audible signal	- "DEF" (diesel exhaust fluid) level below 10%.
 +  + audible signal	- Consult your dealer as soon as possible.



### CRYSTALLIZATION OR SULFURIZATION LEVEL INDICATOR

If the indicator lamp flashes while the lift truck is running, perform a "STATIONARY LIFT TRUCK" EXHAUST REGENERATION (<math>\leq 3</math> - MAINTENANCE: OCCASIONAL MAINTENANCE).

**INFORMATION SCREEN**



HIGH BEAM HEADLIGHTS INDICATOR



LOW BEAM HEADLIGHTS INDICATOR

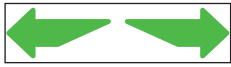

TURN SIGNAL INDICATOR



PARKING BRAKE LAMP



BEACON INDICATOR



BOOM ANGLE



MAINTENANCE REQUIRED



MAINTENANCE OVERDUE



MAINTENANCE OVERDUE + NUMBER OF ERROR CODES



HYDRAULIC MOVEMENT NEUTRALIZATION



NOT USED



GEAR RATIO



MANUAL TRANSMISSION



AUTOMATIC TRANSMISSION



WHEEL STEERING INDICATOR



CLOCK



DRIVING MODE



WORK MODE



CAMERA (OPTION)



EXTERNAL TEMPERATURE





### HOUR METER

- This screen is displayed for a few seconds when the ignition is switched on.



### SPEEDOMETER

- This screen is displayed in driving mode.



### HYDRAULIC FLOW RATE ADJUSTMENT

- This screen is displayed in work mode.

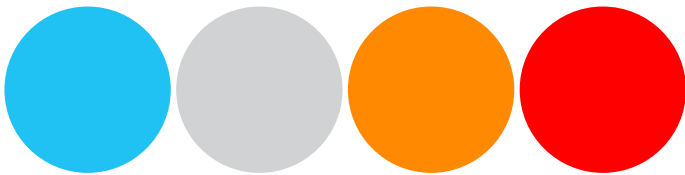

### POP UP

- Blue POP UP: information message.
- Grey POP UP: operating message.
- Orange POP UP: warning message.
- Red POP UP: fault warning message, consult your dealer.



### INFORMATION SCREEN

- Hold down and turn the navigation knob A to change the mode.

- Total hour meter.
- Partial hour meter.
- Instantaneous fuel consumption.
- Average fuel consumption.
- Fuel autonomy.
- Tachometer.



## 11 - ANGULAR SECTOR ON BOOM

The angular sector displays the boom angle, and thus improves the reading of the load charts.

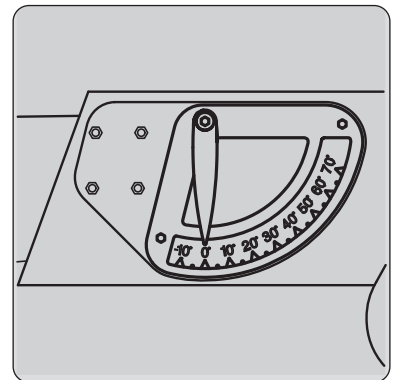

## 12 - INFORMATION SCREEN CONTROL CONSOLE

NOTE: The content of the "PREFERENCES" and "INFORMATION" menus varies according to the lift truck equipment.



### A - NAVIGATION AND VALIDATION BUTTON

#### B - Preferences MENU

- Press button B to display the "PREFERENCES" menu
- Turn knob A to navigate through the menus and sub-menus.
- Press knob A to confirm.

SYSTEM	> DATE AND TIME	
	> LANGUAGES	
	> UNITS	
	> SCREEN	
	> POP UPS	
	> DIGICODE (OPTION)	
	> CAMERAS (OPTION)	
	> CUSTOMER CODE	
	> CONFIGURATION (customer or expert code)	> PARTIAL HOUR METER RESET
		> MAINTENANCE HOUR METER RESET
TRANSMISSION	> ECO MODE (OPTION)	
	> MANUAL ACCELERATOR (OPTION)	
	> TRAILER BRAKE TEST (OPTION)	
HYDRAULICS	> STABILITY REBALANCING	
	> LSU HYDRAULICS	
	> STABILITY TEST	
	> EASY CONNECT SYSTEM (OPTION)	
	> JSM AUTOPOWER	
	> AXLE BLOCKING TEST	
	> CONFIGURATION (customer or expert code)	> OVERRIDE
		> FORCED OPERATION NO DRIVER
ENGINE SPECIFICATION	> ECO STOP (OPTION)	
	> FAN DRIVE VENTILATION REVERSAL	
	> REGENERATION	
EXPERT (expert code)	> STABILITY CALIBRATION	
	> BOOM ANGLE CALIBRATION	
	> PEDAL CALIBRATION INCHING	
	> CARRIAGE ANGLE CALIBRATION	
	> DISTRIBUTOR CALIBRATION	
	> INCLINOMETER CALIBRATION	
	> EXPERT CODE	

### C - INFORMATION MENU

- Press the button to display the "INFORMATION" menu
- Turn knob A to navigate through the menus and sub-menus.
- Press knob A to confirm.

TROUBLESHOOTING	> FAULTS
MAINTENANCE	> MAINTENANCE RESET
GENERAL	> IDENTIFICATION
	> SOFTWARE VERSION
HYDRAULICS	> OIL LEVEL

### D - BACK

- Press the button to return to the previous screen.



#### HYDRAULIC MOVEMENT NEUTRALIZATION

When driving on the road, it is highly recommended (mandatory in Germany) that you disconnect all hydraulic movement. The indicator lamp will light and the  pictogram will be displayed on the screen when it is in use.



#### ROTATING BEACON LIGHT

The indicator lamp indicates it is in use.



#### HAZARD WARNING LIGHTS

### 13 - PUSH BUTTON PANEL

#### PUSH BUTTON FUNCTIONS

- Red button: Safety.
- Orange button: Transmission / Engine.
- Blue button: Hydraulics.
- Black button: Other.

#### PUSH BUTTON DIAGNOSTICS

- If all buttons are unlit, there is a power supply problem. Contact your dealer.
- If all buttons are flashing, there is a connection problem. Contact your dealer.



#### TRANSMISSION CUT-OFF

##### USE OF TRANSMISSION CUT-OFF

- Indicator lamp on, transmission is cut off with the service brake pedal and the forward/neutral/reverse gear lever.
  - When loading.
- Indicator lamp off, transmission is cut off with the forward/neutral/reverse gear selector.
  - When driving.
  - For inching and continuous stop/start (delicate handling).



#### AUTOMATIC TRANSMISSION (OPTION)

#### ⚠ IMPORTANT ⚠

*Before switching to automatic transmission, stop the lift truck and place the forward/reverse selector in neutral.*

- Press the button to switch to automatic transmission.
- The light is on, gear changes are automatic and the pictogram  on the information screen indicates that it is in use.



#### ENGINE SPEED MEMORIZATION (OPTION)

##### DESCRIPTION AND USE OF THE OPTIONS



#### GEAR RATIO MEMORIZATION (OPTION)

##### DESCRIPTION AND USE OF THE OPTIONS



#### "MANUAL MODE" AUTOMATIC PARKING BRAKE

- Press the  button to activate. The indicator lamp will show it is in use.
- Press the button again to deactivate.



#### AUTOMATIC PARKING BRAKE

The function is used to engage the parking brake when the lift truck is stopped and to release the parking brake when the lift truck movement conditions are met.

- Press the  button to activate. The indicator lamp will show it is in use.
- Press the button again to deactivate.



#### USE OF FRONT OR REAR ATTACHMENT SYSTEM (OPTION)

##### DESCRIPTION AND USE OF THE OPTIONS



### BOOM SUSPENSION (OPTION)

< DESCRIPTION AND USE OF THE OPTIONS



### FORCED BOOM SUSPENSION (OPTION)

< DESCRIPTION AND USE OF THE OPTIONS



### ATTACHMENT CIRCUIT FLOW RATE LIMITER (OPTION)

< DESCRIPTION AND USE OF THE OPTIONS



### ATTACHMENT CIRCUIT MANUAL OVERRIDE (OPTION)

< DESCRIPTION AND USE OF THE OPTIONS



### TILT CIRCUIT LOCKING (OPTION)

- Press the button to shut off the tilt circuit hydraulic movements. The indicator lamp indicates it is in use.



### ATTACHMENT CIRCUIT LOCKING (OPTION)

- Press the button to shut off the attachment circuit hydraulic movements. The indicator lamp indicates it is in use.



### INTELLIGENT HYDRAULICS FUNCTIONS "INTELLIGENT HYDRAULICS" (OPTION)

< DESCRIPTION AND USE OF THE OPTIONS



### AUTOMATIC VENTILATION REVERSAL

Cleans the radiator core and the grille of the engine hood by reversing the air flow.

#### ⚠ IMPORTANT ⚠

*The ventilation reversal is operational from an engine coolant temperature of 40 °C.*

*When in use, beware of the risk of projection into the eyes.*

- The indicator light is on, the fan operates in self-cleaning mode for a few seconds once every 3 minutes.
- By default, the cycle time is 3 minutes.
- Press button B to display the "PREFERENCES" menu
- Turn knob A to navigate through the menus and sub-menus.



ENGINE SPECIFICATION > "FAN DRIVE" VENTILATION REVERSAL

- Select the cycle time and press knob A to confirm.



### FORCED VENTILATION REVERSAL

- Press the button to force a cleaning cycle. The indicator lamp will light when it is in use.
- Wait for the cycle time between each request.



### FRAME LEVELING ON LEFT MLT 1041 145 PS+ LY ST5 S1



### FRAME LEVELING ON RIGHT MLT 1041 145 PS+ LY ST5 S1

NOTE: The tilt correction may only be performed if the lifting angle for the boom is less than 34°.



### SEMI-AUTOMATIC WHEEL ALIGNMENT (OPTION)

< DESCRIPTION AND USE OF THE OPTIONS



### EXHAUST REGENERATION

< 3 - MAINTENANCE: OCCASIONAL SERVICING



### ECO STOP (OPTION)

< DESCRIPTION AND USE OF THE OPTIONS



NOT USED

## 14 - SWITCHES



### BOOM HEAD WORKLIGHTS (OPTION)



### FRONT WORKLIGHTS



### REAR WORKLIGHTS



### SIDE WINDSHIELD WIPER (OPTION)



### SIDE WORKLIGHTS (OPTION)



### REAR FOG LIGHTS (OPTION)



### BOOM HEAD ELECTROVALVE (OPTION)



### BOOM ELECTRICAL PREDISPOSITION (OPTION)

< DESCRIPTION AND USE OF THE OPTIONS



### "COMFORT STEERING SYSTEM" (OPTION)

< DESCRIPTION AND USE OF THE OPTIONS



### REAR WINDSHIELD DEFROST

### MAIN RIGHT REAR-VIEW MIRROR DEFROST (OPTION)



## 15 - 12 V SOCKET

For 12 V appliance and max. amperage 10A.

## 16 - DIAGNOSTIC PLUG

## 17 - USB CHARGING SOCKET



## 18 - LIGHTING, HORN AND INDICATOR SWITCH

The switch controls the visual and sound alarms.

- A - All lights are off, the turn signals work.
- B - The right hand indicator lights flash.
- C - The left hand indicator lights flash.
- D - Parking and rear lights on.
- E - The low beam headlights and the rear lights are on.
- F - The high beam headlights and the rear lights are on.
- G - Headlight signaling.

Pressing the end of the switch sounds the horn.

NOTE: Positions D - E - F - G can be used without switching on the ignition.

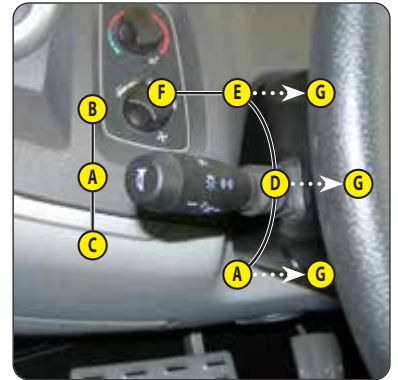

## 19 - FRONT AND REAR WINDSHIELD WIPER SWITCH

FRONT WINDSHIELD WIPER

- A - Front windshield wiper off.
- B - Front windshield wiper low speed setting.
- C - Front windshield wiper low speed setting.
- D - Front windshield wiper intermittent operation.
- E - Front windshield wiper pulse driven.

REAR WINDSHIELD WIPER

- F - Rear windshield wiper off.
- G - Rear windshield wiper on.
- H - Rear windshield washer, pulse driven (not used).

NOTE: These functions will only work when the ignition is switched on.

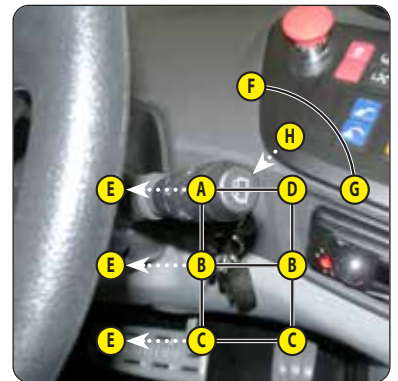

## 20 - FUSES AND RELAYS IN THE CAB

A sticker on the inside of the access panel provides a quick indication of the use of the fuse plate's components described below.

- Remove access panel 1 to gain access to the fuses and relays. Replace a blown fuse with a new fuse of the same quality and rating. Never use a repaired fuse.

### MINIFUSE

F1	15A	Relay (K4 K21).
F2	20A	Window winder.
F3	20A	Front windshield wiper. Front windshield washer. Relay (K1).
F4	10A	Rear windshield wiper. Rear windshield washer.
F5	10A	12 V plug.
F6		
F7	5A	JSM joystick.
F8	5A	Screen/navigator wake-up.
F9	5A	Relay (K3).
F10	5A	Diagnostics plug.
F11	5A	Brake system pressure sensors
F12	2A	Immobilizer (OPTION).
F13	2A	Customer immobilizer (OPTION).
F14	5A	Car radio.
F15	7,5A	Trailer brake valve Pneumatic brake Sensors.
F16	10A	Side windshield wiper Side windshield washer.
F17	15A	Pneumatic seat (OPTION).
F18	20A	Main ECU SPU 40-26.
F19	15A	Side worklights (OPTION).
F20	15A	3-pin 12 V connector (OPTION).

F21	5A	Boom head electric power socket (OPTION).
F22	15A	Engine ECU wake-up. Engine sensor.
F23	20A	Front worklights.
F24	10A	Stop light.
F25	7,5A	Transmission ECU.
F26	7,5A	Relay (K12).
F27	5A	Wheel alignment sensors.
F28	5A	Boom angle sensor.
F29		
F30	5A	Carriage angle sensor power supply (OPTION). Boom head camera (OPTION).
F31	5A	Relay (K15) (OPTION). Central lubrication (OPTION).
F32	5A	"Comfort steering system"(OPTION).
F33	5A	Boom retraction slowing and overload sensors (OPTION).
F34	7,5A	Electric rear-view mirror and defrost (OPTION).
F35	7,5A	Self-cleaning fan.
F36	10A	Rear hydraulic solenoid valve Boom head solenoid valve (OPTION).
F37	15A	Worklights on boom (OPTION).
F38	15A	Auxiliary ECU SPU 25-15.
F39	15A	Rear worklights (OPTION).
F40	15A	Greasing unit (OPTION).

F41	10A	Transmission ECU.
F42		
F43	20A	Main ECU SPU 40-26.
F44		
F45	10A	Front windshield wiper automatic return.
F46	10A	Rear windshield wiper automatic return.
F47	10A	Side windshield wiper automatic return.
F48	7,5A	Horn.
F49	7,5A	Relay (K6).
F50	5A	Relay (K2).

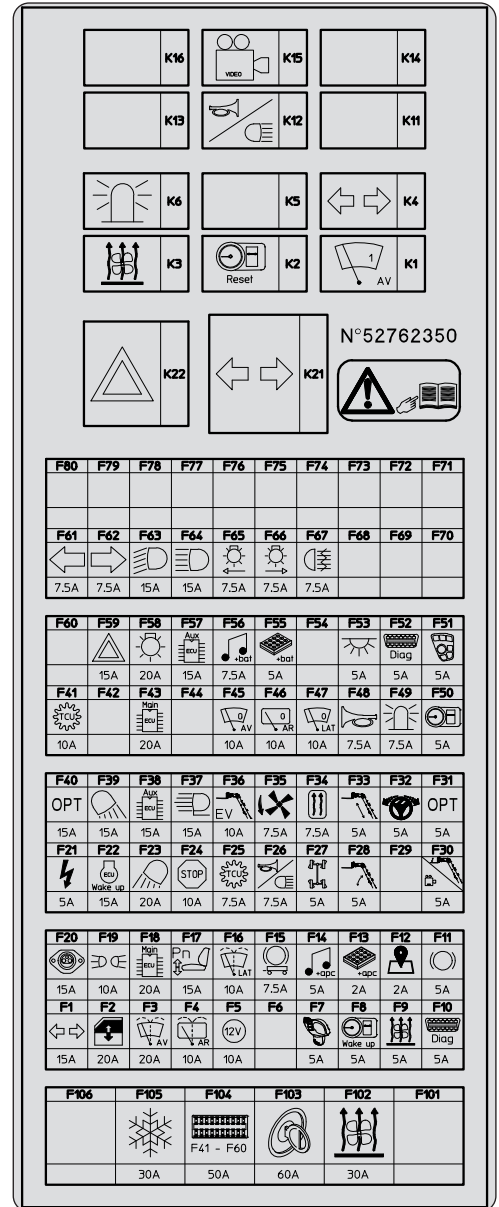

F51	5A	Information screen control console.
F52	5A	Diagnostics plug.
F53	5A	Roof light.
F54		Unused.
F55	5A	Customer immobilizer (OPTION).
F56	7,5A	Car radio
F57	15A	Auxiliary ECU SPU 25-15.
F58	20A	Lighting, horn and indicator switch.
F59	15A	Relay (K4).
F60		

F61	7,5A	Left turn signals.
F62	7,5A	Right turn signals.
F63	15A	Low beam headlights.
F64	15A	High beam headlights.
F65	7,5A	Left parking lights.
F66	7,5A	Right parking lights.
F67	7,5A	Rear fog lights.
F68		Unused.
F69		Unused.
F70		Unused.
F71		Unused.
F72		Unused.
F73		Unused.
F74		Unused.
F75		Unused.
F76		Unused.
F77		Unused.
F78		Unused.
F79		Unused.
F80		Unused.

F95	2A	Immobilizer (OPTION).
-----	----	-----------------------

### MAXIFUSE

F101		Unused.
F102	30A	Relay (K3).
F103	60A	Ignition switch.
F104	50A	Module 3 fuses (F41 - F60).
F105	30A	Air conditioning (OPTION).
F106		Unused.

### RELAYS

K1	Front windshield wiper speed 1.
K2	Dashboard power supply.
K3	Ventilation/heating.
K4	Flashing light unit power supply.
K5	Unused
K6	Rotating beacon.

K11	Unused.
K12	Reversing lights and backup alarm.
K13	Unused.
K14	Trailer brake test (OPTION).
K15	Camera control (OPTION).
K16	Unused.

K21	Flashing unit.
K22	Hazard warning lights.

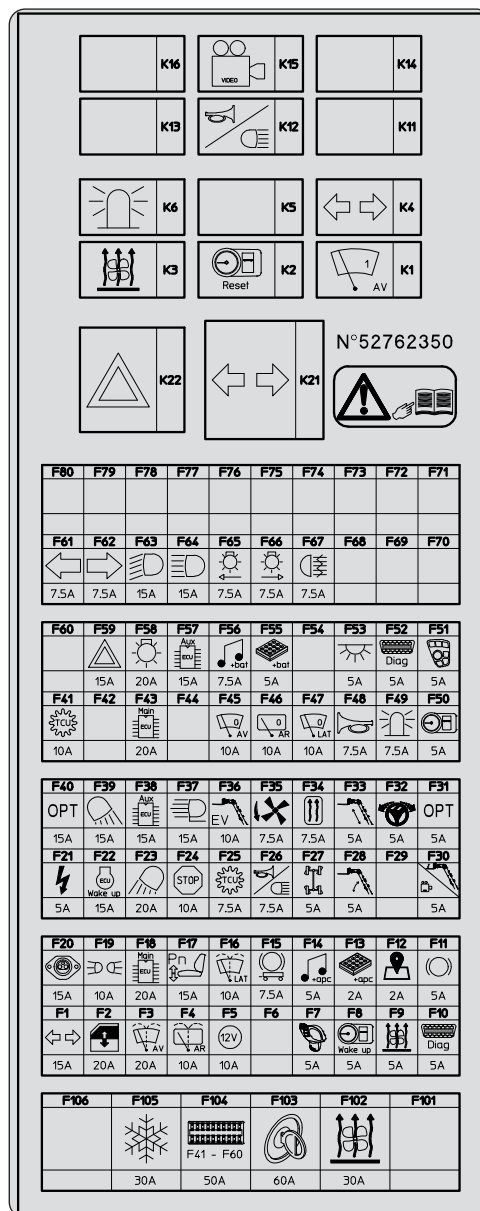

## 21 - FUSES AND RELAYS UNDER THE ENGINE HOOD

- Open the engine hood, remove cover 1 to gain access to the fuses and relays.  
Replace a blown fuse with a new fuse of the same quality and rating. Never use a repaired fuse.



### MAXIFUSE

F71		Unused.
F72		Unused.
F73	80A	Module 2 fuses (F81 - F90).
F74	30A	Relay power supply (K32).
F75	30A	Relay power supply (K41).
F76	20A	Power supply (OPTION).

### MINIFUSE

F81	10A	Fuel pump.
F82	5A	Pressure line preheat
F83	5A	Return line preheat
F84	5A	Suction line preheat
F85		Unused.
F86	10A	Engine start (K31).
F87	5A	Engine diagnostic plug (K33).
F88	10A	Sensors NOx (K34).
F89	15A	Quality, level and temperature sensor "DEF" (K35).
F90		Unused.

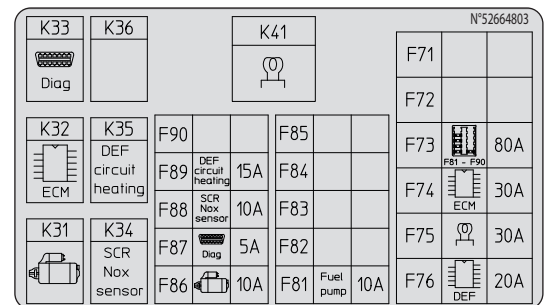

### RELAYS

K31	Engine start-up
K32	Engine ECU
K33	Diagnostics plug.
K34	Sensors NOx.
K35	Heating system "DEF".
K36	
K41	Preheat.

## 22 - FORWARD/NEUTRAL/REVERSE GEAR SELECTION

When changing the direction of travel, the lift truck should be traveling at slow speed and not accelerating.

- FORWARD: Push the switch forward (position A).
- REVERSE: Push the switch backward (position B). Reversing lights and a backup alarm indicate that the lift truck is traveling in reverse.
- NEUTRAL: The switch must be in the neutral position (position C) to start the lift truck.

NOTE: Backup alarm (OPTIONAL or STANDARD).

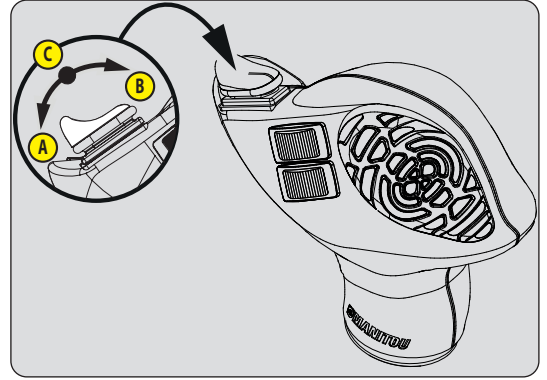

### SAFETY FOR MOVING THE LIFT TRUCK

The operator must observe the following sequence to move the truck forward or backward:

- 1 - sit down correctly in the driver's seat,
- 2 - release the hand brake,
- 3 - engage forward or reverse gear.

NOTE: The alternate display of the forward or reverse section arrow  on the information screen requires the selector to be set to neutral.

To stop the forklift truck without switching off the ignition, the following sequence must be followed:

- 1 - set the forward/reverse selector to neutral,
- 2 - apply the parking brake,
- 3 - get out of the lift truck.

NOTE: A discontinuous audible signal and a message on the screen will inform the driver if he has left the driver's cab without applying the parking brake.

## 23 - GEAR SELECTOR

The gear is selected by means of the (-) and (+) buttons. The selected gear is indicated on the information screen .

NOTE: When reversing the direction of travel, the selected gear remains the same, except for the 4th, 5th and 6th forward gears which become 3rd gear in reverse.

### CONDITION OF USE OF GEARBOX RATIOS

On lift trucks such as these, that are equipped with torque converters, it is not necessary to systematically set off in first gear and work up through the gears.

#### **⚠ IMPORTANT ⚠**

*The gearbox ratio selection should be made carefully depending on the work to be performed.*

*A poor choice may result in the extremely rapid rise of the gearbox oil temperature through excessive slipping of the converter, which could lead to serious gearbox damage (it is essential to stop and change the working conditions if the gearbox oil temperature indicator light comes on).*

*This poor choice may also result in the forklift truck's performance deteriorating in forward gear: When the forward force increases, the forward speed in the r ratio (for example, in 3rd gear) may be lower than the forward speed that could be obtained with the r-1 gear (in 2nd instead of 3rd).*



## 24 - STEERING SELECTION

### ⚠ IMPORTANT ⚠

*Before selecting one of the three steering possibilities, align the 4 wheels in relation to the lift truck axis.  
Never change the steering mode whilst driving.*



The green indicator lights  on the information screen come on to indicate the alignment of the wheels relative to the lift truck.

### A - STEERING SELECTION SWITCH



Front steering wheels (road mode).



Front and rear steering wheels in opposite directions (short steering).



Front and rear steering drive wheels in the same direction (crab steering).



Front steering wheels and locking of the rear wheel steering angle.





- Align the rear and front wheels.
- Select the desired steering mode, a flashing indicator lamp will confirm the selection.
- Turn the wheels as instructed on the information screen. The indicator lamp will remain steadily lit while the steering mode is enabled.



### CHECKING WHEEL ALIGNMENT

### ⚠ IMPORTANT ⚠

*Check the alignment of the front and rear wheels each time the lift truck is started.  
Regularly check the alignment of the wheels when using the lift truck.  
The wheels must be aligned and the lift truck must be in front steering wheels mode when used on public roads.  
A green light illuminates on the dashboard when the wheels are aligned.  
Contact your dealer if you have any questions.*

- Select "short steering" ).
- Turn the steering wheel and bring the rear wheels into alignment until the  indicator lamps light on the rear wheels.
- Select "road driving" .
- Turn the steering wheel and bring the rear wheels into alignment until the  indicator lamps light on the front wheels.

## 25 - ACCELERATOR PEDAL

### 26 - SERVICE BRAKE PEDAL AND TRANSMISSION CUT-OFF

The pedal applies on the front and rear wheels by an hydraulic brake system, and allows the lift truck to be slowed down and stopped. Depending on the position of the transmission cut-off switch, it enables the transmission to be cut off during the free travel (⇐ PUSH BUTTON PANEL).

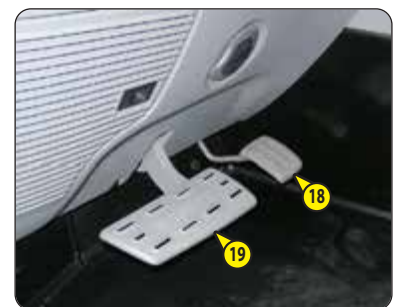

### 27 - FUNCTION FILES

These files contain the description of the hydraulic controls and the load charts for the attachments used on the lift truck.



## 28 - HYDRAULIC BOOM CONTROLS

### ⚠ IMPORTANT ⚠

**Do not try to modify the hydraulic pressure of the system. If it malfunctions contact your dealer. ANY MODIFICATION INVALIDATES THE WARRANTY AND YOU WILL BE CRIMINALLY LIABLE IN THE EVENT OF AN ACCIDENT.**

**Use the hydraulic controls gently without jerking, to avoid incidents caused by shaking the lift truck.**

NOTE: If necessary, operate the steering to reset the hydraulic control steering accumulator.

NOTE: When driving on the road, it is highly recommended (mandatory in Germany) that you disconnect all hydraulic movement (⇐ PUSH BUTTON PANEL).

### HYDRAULIC CONTROLS ACTIVATION

This safety device prevents accidental operation of the hydraulic lifting, tilting, telescoping and attachment controls.

- Place your hand on the lever, activate the hydraulic controls by contact on sensor 1 and perform the hydraulic movement.
- Hydraulic controls activation is maintained on a timer while the lift truck is being used.
- If necessary, reactivate the hydraulic controls.

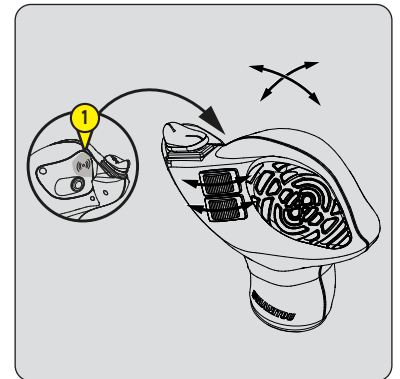

**A1 - LIFTING**

**A2 - LOWERING**

**B1 - CROWD**

**B2 - DUMP**

**C1 - TELESCOPE EXTENSION**

**C2 - TELESCOPE RETRACTION**

**D1 - ATTACHMENT**

**D2 - ATTACHMENT**

**E - HYDRAULIC CONTROL (OPTION)**

⇐ DESCRIPTION AND USE OF THE OPTIONS

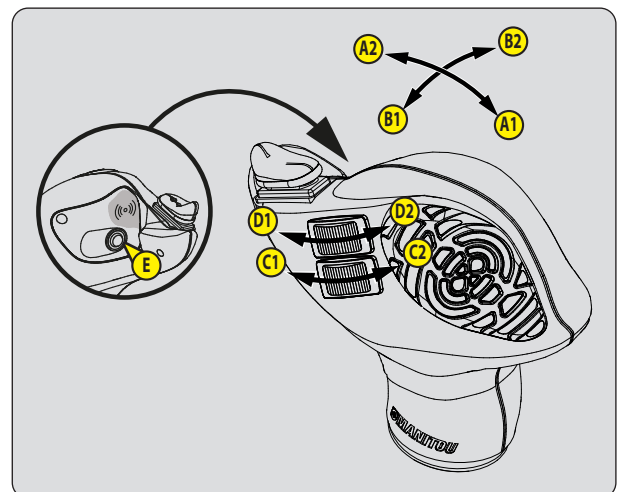

## 29 - LEVEL INDICATOR

**A - SPIRIT LEVEL**

Enables the operator to check that the lift truck is in the horizontal position.

**B - TILT INDICATOR**      MLT 1041 145 PS+ L Y ST5 S1

When the two marks are aligned, the chassis is parallel with the front axle.

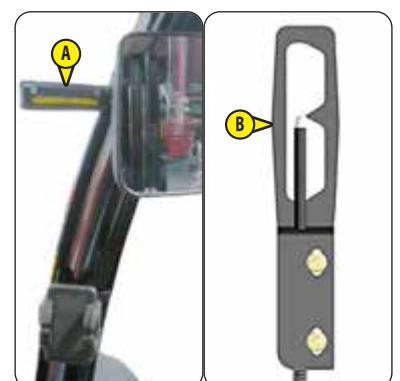

647874-EN-USM3 B102023  
MLT 841 145 PS+ Y ST5 S1  
MLT 1041 145 PS+ L Y ST5 S1

## 30 - HEATER CONTROL

### A - FAN CONTROL

This 4-speed control allows the air to be ventilated through the air vents.

### B - TEMPERATURE CONTROL

Adjusts the temperature inside the cab.

- B1 - The fan pumps in the air at ambient temperature.
- B2 - The fan pumps in warm air.

The intermediate positions allow the temperature to be adjusted.



## 31 - AIR CONDITIONING CONTROLS (AIR CONDITIONING OPTION)

### ⚠ IMPORTANT ⚠

*The air conditioning only works if the lift truck has been started.*

*When using your air conditioning, it is essential to work with the cab closed.*

*In winter: So as to ensure that the air conditioning unit is correctly operated and completely efficient, start up the compressor once a week, even for a short period of time, in order to lubricate the internal seals.*

*In cold weather: Warm the engine before switching on the compressor, in order to allow the coolant that has collected in the liquid state at the lowest point of the compressor's circuit to turn into gas under the effect of the heat given off by the engine, as the compressor is liable to be damaged by coolant in the liquid state.*

*If it seems to you that the air conditioning is not working properly, have it inspected by your dealer.*

*Never try to repair any faults yourself.*

### A - FAN CONTROL

This 4-speed control allows the air to be ventilated through the air vents.

### B - TEMPERATURE CONTROL

Adjusts the temperature inside the cab.

- B1 - The fan pumps in cold air.
- B2 - The fan pumps in warm air.

The intermediate positions allow the temperature to be adjusted.

### C - AIR CONDITIONING CONTROL

This control with a pilot light allows the air conditioning unit to be switched on.

#### HEATING MODE

- The controls must be adjusted in the following way:
  - C - Control with pilot light off.
  - B - At the desired temperature.
  - A - At the desired speed: 1, 2 or 3.

#### AIR CONDITIONING MODE

- The controls must be adjusted in the following way:
  - C - Control with pilot light on.
  - B - At the desired temperature.
  - A - At the desired speed: 1, 2 or 3.

#### DEFROST MODE

- The controls must be adjusted in the following way:
  - C - Control with pilot light on.
  - B - At the desired temperature.
  - A - At speed 2 or 3.
- For optimum effectiveness, close the heating vents.



## 32 - HEATING VENTS

These swiveling heating vents, which can be shut off, allow you to direct and adjust the flow inside the cab.

## 33 - WINDSHIELD DEFROSTER VENTS

For optimum effectiveness, close the heating vents.

### 34 - WINDOW WINDER

---

### 35 - DOOR OPENING AND CLOSING HANDLE

---

Two keys are provided with the lift truck to enable the cab to be locked.

- Press the door handle trigger to open the door.
- Pull on the handle to close the door.



### 36 - REAR WINDOW STAY

---

#### EMERGENCY EXIT

Use the rear window as an emergency exit, in the event that it is impossible to leave the cab by the door or by opening the windshield.

- Remove the pin to fully open the rear window.

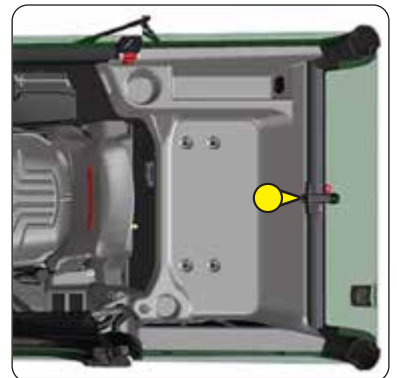

### 37 - STORAGE NET

---

Ensure that the operator's manual is in its place in the storage net.



### 38 - STORAGE

---

### 39 - CUP HOLDER

---



### 40 - FRONT HEADLIGHTS

---

- A - Front left-hand indicator light.
- B - Front left-hand dipped headlight.
- C - Front left-hand headlight.
- D - Front left-hand sidelight.
- E - Front right-hand indicator light.
- F - Front right-hand low beam headlight.
- G - Front left-hand high beam headlight.
- H - Front right-hand sidelight.



### 41 - REAR LIGHTS

- A - Rear left-hand indicator light.
- B - Rear left-hand stop light.
- C - Rear left-hand headlight.
- D - Rear fog light.
- E - Rear reversing light.
- F - Rear right hand headlight.
- G - Rear right-hand stop light.
- H - Rear right-hand indicator light.

**⚠ IMPORTANT ⚠**

*When driving on the road, turn back the rear lights using the bolts 1.*

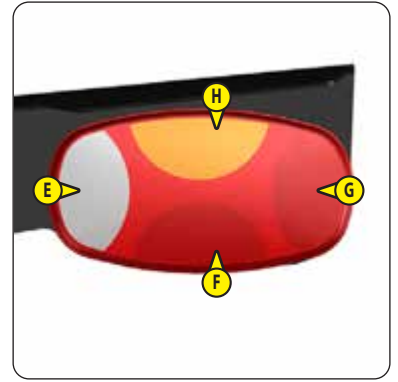
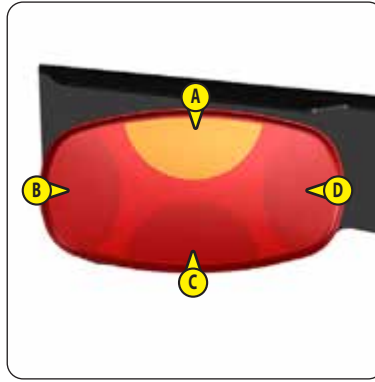

### 42 - ROTATING BEACON LIGHT

The magnetic rotating beacon light must be clearly visible on the roof of the cab and plugged-in to socket 1.



### 43 - SUN VISOR

### 44 - ROOF LIGHT

### 45 - HOOK



### 46 - INTERNAL REAR-VIEW MIRROR

### 47 - TELEPHONE HOLDER



## 48 - STEERING WHEEL ADJUSTMENT LEVER

This handle enables the angle and height of the steering wheel to be adjusted.

- Pull the knob backwards.
- Adjust the steering wheel to the desired position.
- Push the knob back to lock the steering wheel in position.



## 49 - EMERGENCY HAMMER

### EMERGENCY EXIT

Use the emergency hammer to break one of the windows in the event that it is impossible to exit the cab by the door or by opening the rear window.



## 50 - BOOM SAFETY WEDGE

### ⚠ IMPORTANT ⚠

*Only use the wedge supplied with the lift truck.*

The lift truck is equipped with a boom safety wedge which must be installed on the rod of the lifting cylinder when working beneath the boom (⚠ 1 - OPERATING AND SAFETY INSTRUCTIONS).



## 51 - BUTTON FOR OPENING THE TANK FILLER ACCESS PANEL

Press the button to open the tank filler access panel.



## 52 - FUEL TANK

As far as possible, keep the fuel tank well filled in order to minimize condensation due to the atmospheric conditions.

### **⚠ IMPORTANT ⚠**

*Never smoke or approach with a flame during filling operations or when the tank is open.*

*Never refill while engine is running.*

- If necessary, add diesel (☞ 3 - MAINTENANCE: LUBRICANTS AND FUEL).
- Remove plug 1.
- Fill the fuel tank with clean diesel filtered through the filler port.
- Refit the cap.
- Visually check that there is no leakage in the tank and pipes.

NOTE: A locking tank cap is available as an OPTION.



## 53 - "DEF" (Diesel Exhaust Fluid) TANK

### **⚠ IMPORTANT ⚠**

*Diesel exhaust fluid is corrosive: protect the bodywork and wear personal protective equipment (gloves and goggles).*

*The Diesel Exhaust Fluid level is important. Operating with a low or empty DEF tank level may affect engine performance.*

- If necessary, add diesel exhaust fluid (☞ 3 - MAINTENANCE: LUBRICANTS AND FUEL).
- Remove plug 1.
- Slowly fill the tank to the bottom of the filler neck.
- Always maintain a good level to avoid alternation of the product.
- Refit the cap.

NOTE: A locking tank cap is available as an OPTION.



### "DEF" (Diesel Exhaust Fluid) QUALITY

The diesel exhaust fluid quality can be measured using a refractometer. The diesel exhaust fluid must comply with standard ISO 22241-1 with a urea concentration of 32.5%.

Refractometer (MANITOU part number: 959709)

### "DEF" (Diesel Exhaust Fluid) STORAGE

Up to 4 months without using the lift truck, check the quality of the diesel exhaust fluid with a refractometer.

Beyond 4 months, replace the diesel exhaust fluid. Empty and rinse the tank.

NOTE: For a prolonged shutdown of the lift truck, ☞ 1 - OPERATING AND SAFETY INSTRUCTIONS: IF THE LIFT TRUCK IS NOT TO BE USED FOR A LONG TIME.

## TOWING DEVICE

1 - CHASSIS-MOUNTED FRONT TOWING HOOK .....	2-57
2 - CLEVIS HITCH .....	2-57
3 - AUTOMATIC CLEVIS HITCH (OPTION) .....	2-57
4 - CLEVIS HITCH ON COUPLING LADDER (OPTION) .....	2-58
5 - AUTOMATIC CLEVIS HITCH ON COUPLING LADDER (OPTION) .....	2-58
6 - AUTOMATIC BALL HITCH ON COUPLING LADDER (OPTION) .....	2-59
7 - FIXED PIN ON COUPLING LADDER (OPTION) .....	2-59
8 - HYDRAULIC TOWING HOOK (OPTION) .....	2-60
9 - REAR ELECTRIC SOCKET .....	2-60
10 - HYDRAULIC TRAILER BRAKING (OPTION) .....	2-61
11 - PNEUMATIC TRAILER BRAKE (OPTION) .....	2-61

### **⚠ IMPORTANT ⚠**

*Do not tow a trailer or an attachment that is not in perfect working condition.*

*Using a trailer in poor condition may affect the lift truck's steering and braking, and hence the safety of the assembly.*

*If a third party helps in coupling or uncoupling the trailer, this person must be permanently visible to the driver and wait until the lift truck has stopped, the handbrake is on and the I.C. engine is switched off before performing the operation.*

Located at the rear of the lift truck, this device is used to attach a trailer. Its capacity is limited for each lift truck by the Authorized Gross Vehicle Weight, tractive force and maximum vertical force on the coupling point. This information is given on the manufacturer's plate fixed to each lift truck ( <img alt="arrow icon" data-bbox="335 615 345 625"/> IDENTIFICATION OF THE LIFT TRUCK).

- To use a trailer, see current regulations in your country (maximum running speed, braking, maximum weight of trailer, etc.).
- Verify the trailer's condition before using it (tire condition and pressures, electrical connection, hydraulic hose, brake system, etc.).

NOTE: Our tractor type-approved lift trucks are not compatible for use with trailers fitted with the ISO7638socket.

## 1 - CHASSIS-MOUNTED FRONT TOWING HOOK

### ⚠ IMPORTANT ⚠

*This pin is only intended for towing or winching the lift truck in the event of a breakdown.*

*⚠ - MAINTENANCE: OCCASIONAL OPERATION for towing or winching the lift truck.*

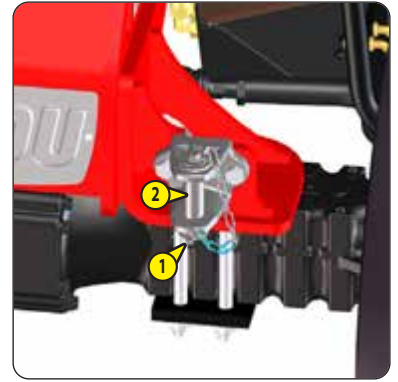

## 2 - CLEVIS HITCH

### ⚠ IMPORTANT ⚠

*Be careful not to get your fingers caught or crushed during this operation.*

*Do not forget to put the cotter pin back in place.*

*When uncoupling, make sure that the trailer is supported independently.*

### COUPLING AND UNCOUPLING THE TRAILER

- To couple the trailer, position the lift truck as close as possible to the trailer ring.
- Apply the parking brake and switch off the engine.
- Remove the pin 1, lift the towing pin 2 and place or remove the trailer ring.



## 3 - AUTOMATIC CLEVIS HITCH (OPTION)

### ⚠ IMPORTANT ⚠

*When uncoupling, make sure that the trailer is supported independently.*

### COUPLING THE TRAILER

- Remove the automatic towing pin using lever 1.
- Back up the lift truck so that the trailer ring slots into the automatic hook.

NOTE: The pin closes automatically when the trailer ring touches the back of the clevis. The pin can be lowered by hand using lever 1.

### UNCOUPLING THE TRAILER

- Lift the pin using lever 1 to uncouple the trailer.



#### 4 - CLEVIS HITCH ON COUPLING LADDER (OPTION)

**⚠ IMPORTANT ⚠**

*Be careful not to get your fingers caught or crushed during this operation.  
When uncoupling, make sure that the trailer is supported independently.*

- Position the lift truck as close as possible to the trailer ring.
- Apply the parking brake and switch off the engine.

##### ADJUSTING THE CLEVIS HITCH

- Lift the handle 1 and pivot it upwards to release the pins 2 on either side of the ladder.
- Support the clevis and adjust it according to the height of the trailer ring.
- Pivot the handle 1 downwards to engage the 2 pins in the ladder and release the handle.

##### COUPLING AND UNCOUPLING THE TRAILER

- Remove the towing pin 3 and place or remove the trailer ring.
- Refit and lock towing pin 3 in position.

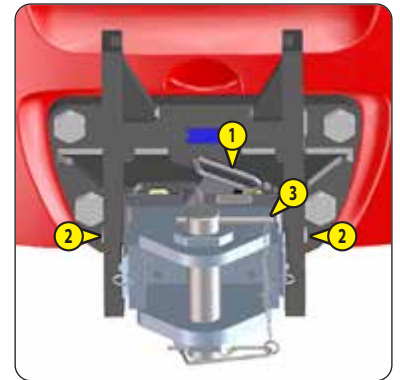
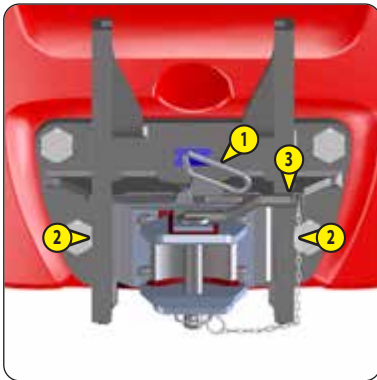
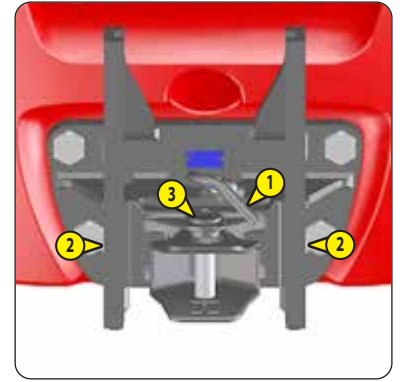

#### 5 - AUTOMATIC CLEVIS HITCH ON COUPLING LADDER (OPTION)

**⚠ IMPORTANT ⚠**

*Be careful not to get your fingers caught or crushed during this operation.  
When uncoupling, make sure that the trailer is supported independently.*

- Position the lift truck as close as possible to the trailer ring.

##### ADJUSTING THE CLEVIS HITCH

- Lift the handle 1 and pivot it upwards to release the pins 2 on either side of the ladder.
- Support the clevis and adjust it according to the height of the trailer ring.
- Pivot the handle 1 downwards to engage the 2 pins in the ladder and release the handle.

##### COUPLING THE TRAILER

- Remove the automatic towing pin using lever 3.
- Back up the lift truck so that the trailer ring slots into the automatic hook.

NOTE: The pin closes automatically when the trailer ring touches the back of the clevis. The pin can be lowered by hand using lever 3.

##### UNCOUPLING THE TRAILER

- Lift the pin using lever 3 to uncouple the trailer.

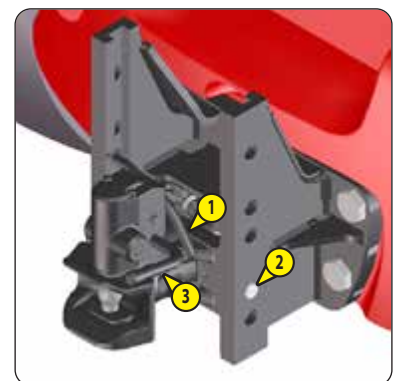

## 6 - AUTOMATIC BALL HITCH ON COUPLING LADDER (OPTION)

### ⚠ IMPORTANT ⚠

*Be careful not to get your fingers caught or crushed during this operation.  
When uncoupling, make sure that the trailer is supported independently.*

- Position the lift truck as close as possible to the trailer ring.

### ADJUSTING THE CLEVIS HITCH

- Lift the handle 1 and pivot it upwards to release the pins 2 on either side of the ladder.
- Support the clevis and adjust it according to the height of the trailer ring.
- Pivot the handle 1 downwards to engage the 2 pins in the ladder and release the handle.

### COUPLING AND UNCOUPLING THE TRAILER

- Remove the cotter pin 3 and the locking pin 4.
- Lift the hitch bolt 5.
- Place or remove the coupling head of the trailer on the ball hitch.
- Refit the hitch bolt 5, the locking pin 4 and the cotter pin 3.

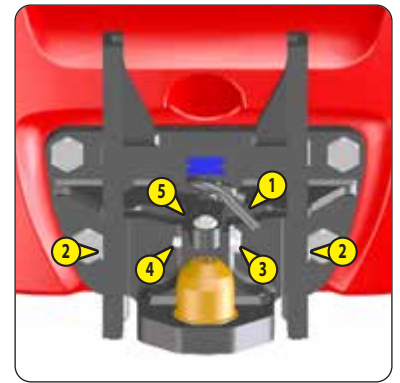

## 7 - FIXED PIN ON COUPLING LADDER (OPTION)

### ⚠ IMPORTANT ⚠

*Be careful not to get your fingers caught or crushed during this operation.  
When uncoupling, make sure that the trailer is supported independently.*

- Position the lift truck as close as possible to the trailer ring.

### ADJUSTING THE CLEVIS HITCH

- Lift the handle 1 and pivot it upwards to release the pins 2 on either side of the ladder.
- Support the clevis and adjust it according to the height of the trailer ring.
- Pivot the handle 1 downwards to engage the 2 pins in the ladder and release the handle.

### COUPLING AND UNCOUPLING THE TRAILER

- Remove the cotter pin 3 and the locking pin 4.
- Lift the hitch bolt 5.
- Place or remove the coupling head of the trailer on the fixed pin.
- Refit the hitch bolt 5, the locking pin 4 and the cotter pin 3.

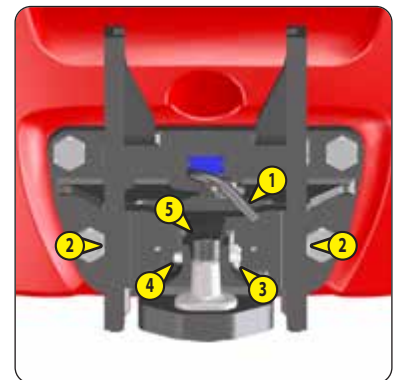

## 8 - HYDRAULIC TOWING HOOK (OPTION)

### ⚠ IMPORTANT ⚠

*Never use the tow hook to raise the rear of the lift truck (when changing the rear wheel for example).  
When uncoupling, make sure that the trailer is supported independently.*

- Select the rear attachment hydraulic line .
- Push switch 1 forwards to release the locking pin securing the hook 2.
- Pull on the knob 3 and hold in position.
- Push switch 1 backwards to lower the towing hook.
- Release knob 3.
- Couple or uncouple the trailer.
- Push switch 1 forwards to fully raise the towing hook.
- Next, push switch 1 backwards to bring the locking pin into contact with the hook 2.

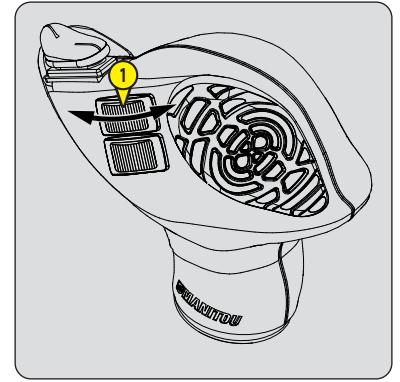
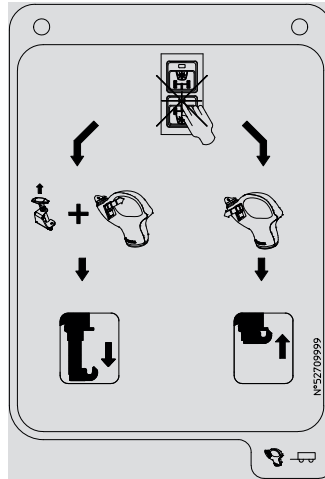

## 9 - REAR ELECTRIC SOCKET

- Connect the male plug to the female socket 1 on the lift truck and make sure the lights of the trailer or the light bar are working properly.

## 10 - HYDRAULIC TRAILER BRAKING (OPTION)

### TRAILER BRAKE WITH A SINGLE "CL" LINE

- Connect the brake hose to the lift truck "CL" line.
- Make sure the trailer brakes are working properly and test the effects of braking before taking the trailer onto the public highway.

### TRAILER BRAKE WITH A DOUBLE "SL" AND "CL" LINE

- Connect the brake hose to the lift truck "CL" line.
- Connect the brake release hose to the lift truck "SL" line.
- Make sure the trailer brakes are working properly and test the effects of braking before taking the trailer onto the public highway.



## 11 - PNEUMATIC TRAILER BRAKE (OPTION)

The pressure gage 1 indicates the working pressure of the pneumatic circuit (8 bar).

- Connect the brake hose to the lift truck "J" line.
- Connect the brake release hose to the lift truck "R" line.
- Make sure the trailer brakes are working properly and test the effects of braking before taking the trailer onto the public highway.

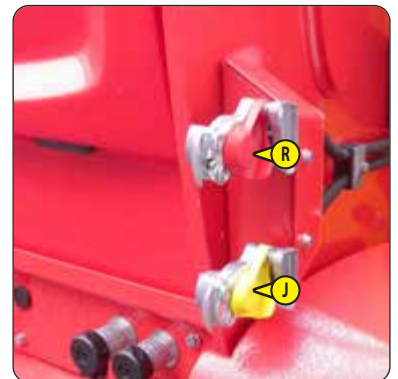

## DESCRIPTION AND USE OF THE OPTIONS

1 - WINDSHIELD GRID .....	2-63
2 - MARKING ON BOOM .....	2-63
3 - AUTOMATIC CENTRAL GREASING .....	2-63
4 - 3 POLE 12V CONNECTOR .....	2-63
5 - RJ45 PLUG (VISION SCREEN OPTION) .....	2-63
6 - IDENTIFICATION KEYPAD "EasyMANAGER" .....	2-64
7 - ELECTRICAL ADJUSTMENT OF MAIN RIGHT REAR-VIEW MIRROR .....	2-64
8 - REAR AND SIDE CAMERAS .....	2-65
9 - BOOM HEAD CAMERA .....	2-65
10 - BOOM ELECTRICAL PREDISPOSITION .....	2-65
11 - ENGINE SPEED REGULATOR .....	2-66
12 - GEAR RATIO LIMITER .....	2-66
13 - "ECO STOP" ENGINE .....	2-67
14 - EXTERIOR DRAIN-BACK .....	2-67
15 - ATTACHMENT EASY HYDRAULIC CONNECTION .....	2-68
16 - HYDRAULIC ATTACHMENT LOCKING .....	2-68
17 - BOOM HEAD ELECTROVALVE .....	2-69
18 - BOOM HEAD ELECTROVALVE + HYDRAULIC ATTACHMENT LOCKING .....	2-70
19 - ATTACHMENT CIRCUIT FLOW RATE LIMITER .....	2-71
20 - ATTACHMENT CIRCUIT MANUAL OVERRIDE .....	2-71
21 - BOOM SUSPENSION .....	2-72
22 - "INTELLIGENT HYDRAULICS" FUNCTIONS .....	2-72
23 - SEMI-AUTOMATIC WHEEL ALIGNMENT .....	2-73
24 - "COMFORT STEERING SYSTEM" .....	2-73
25 - DOUBLE-ACTING REAR HYDRAULIC CONTROL PREDISPOSITION .....	2-74
26 - TWO DOUBLE-ACTING REAR HYDRAULIC CONTROL PREDISPOSITIONS .....	2-75
27 - HYDRAULIC TRAILER HOOK + DOUBLE-ACTING REAR HYDRAULIC CONTROL PREDISPOSITION .....	2-75

## 1 - WINDSHIELD GRID

### DESCRIPTION

The windshield grid provides additional protection for the operator from any external elements spattered on the windshield.

This grid must be removable from inside the cab to enable an emergency exit.

### EMERGENCY EXIT

- After breaking the windshield with the emergency hammer, push (with force) on the windshield grid at A to remove it.



## 2 - MARKING ON BOOM

The marking indicates the outreach of the boom and therefore improves reading of the load charts.

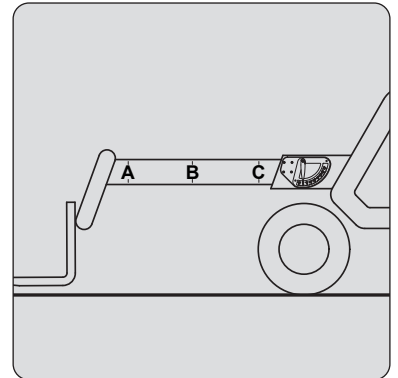

## 3 - AUTOMATIC CENTRAL GREASING

### ⚠ IMPORTANT ⚠

*Before using the lift truck, check the condition of the greasing unit and check the grease level, topping it up, if necessary (↩ 3 - MAINTENANCE: 10H - DAILY SERVICING OR EVERY 10 HOURS OF SERVICE).*

*Never use the lift truck with the grease tank empty.*

*When washing the lift truck with a high-pressure cleaner, the greasing unit must be protected from splashes.*

This option ensures automatic lubrication of all of the lift truck's greasing points from start-up.

After turning on the ignition, check the automatic greasing control indicator light 1:

- Light on for 3s = system OK.
- Light flashing every 0.5s = greasing cycle in progress.
- Light flashing every 1s = grease level low (error code 8C-7F07E.11).
- Light on continuous = grease tank empty or system error.

In the event of a system error, perform a test cycle by pressing test button 2:

- Press once and the light flashes once every 2 seconds and initiates the test on output 1.
- Press twice and the light flashes twice every 2 seconds and launches the test on output 2.

NOTE: After an interruption, when the system is powered back on, the greasing cycle continues where it stopped previously.

If the system error persists, contact your dealer as soon as possible.



## 4 - 3 POLE 12V CONNECTOR

For 12 V appliance and max. amperage 16A.

## 5 - RJ45 PLUG (VISION SCREEN OPTION)

Software maintenance plug



## **6 - IDENTIFICATION KEYPAD "EasyMANAGER"**

A code must be created for the operator via the "EasyMANAGER" portal. For more information, contact your dealer.

### **OPERATION**

#### **BY ID CODE**

- Switch on lift truck ignition, LED 1 comes on.
- Enter your ID code and conform by pressing the "V" key.
- LED 2 comes on to confirm the operator's identification.
- Immediately start the lift truck, otherwise the identification process is canceled and LED 2 turns red.

NOTE: In case of an input error, LED 2 lights up red, press the "X" key, and wait 10 seconds before entering the correct identification code.

#### **BY ID CARD**

- Switch on lift truck ignition, LED 1 comes on.
- Present your ID card; an audible beep confirms that the card has been read.
- LED 2 comes on to confirm the operator's identification.
- Immediately start the lift truck, otherwise the identification process is canceled and LED 2 turns red.



## **7 - ELECTRICAL ADJUSTMENT OF MAIN RIGHT REAR-VIEW MIRROR**



## 8 - REAR AND SIDE CAMERAS

To activate a camera:

- Turn knob A to select the rear or side camera .
- The screen displays the view of the selected camera.

The rear camera (SafeView) can be configured in automatic mode when in reverse gear.

- Press button B to display the "PREFERENCES" menu.
- Turn knob A to select the menu.

SYSTEM > CAMERA (OPTION)

- Press knob A to confirm.
- Activate the automatic configuration using knob A.
- Press knob A to confirm.



## 9 - BOOM HEAD CAMERA

To activate the camera:

- Turn knob A to select the boom head camera .
- The screen displays the view of the selected camera.

The boom head camera (HighView) can be configured in automatic mode as soon as the boom angle reaches 25°. When the boom goes back down, the previous screen reappears.

- Press button B to display the "PREFERENCES" menu.
- Turn knob A to select the menu.

SYSTEM > CAMERA (OPTION)

- Press knob A to confirm.
- Activate the automatic configuration using knob A.
- Press knob A to confirm.

NOTE: "Manual" selection of the boom head camera from the information screen activates it permanently. The boom head camera (HighView) can be combined with the rear and side cameras option (SafeView).

### BOOM HEAD CAMERA INSTALLATION

- Lower the boom as far as it will go and turn off the lift truck ignition.
- Position the indexing finger 1 and tighten the thumbwheels 2.
- Point the camera using the thumbwheel 3.

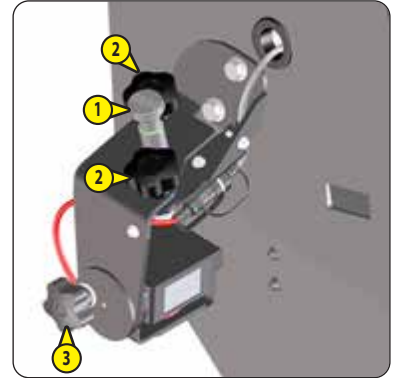

## 10 - BOOM ELECTRICAL PREDISPOSITION

Enables an electrical function to be used at the boom head.

### OPERATION

- Press the switch. The indicator  will come on when the function is enabled.



## 11 - ENGINE SPEED REGULATOR



### ⚠ IMPORTANT ⚠

*The engine speed regulator cannot under any circumstances be used while driving on the road.*



#### USING THE REGULATOR

- Control the engine speed with lever 1.

#### SPEED MEMORIZATION

- Control the engine speed with lever 1 or the accelerator pedal.
- Hold down the  button to memorize the engine speed.
- Press the  button again or operate lever 1 to return to idle speed.

#### ACTIVATING THE MEMORIZED ENGINE SPEED

- Press the  button to activate the memorized engine speed.
- Confirm by pressing the  button a second time or pressing knob A.
- Press the  button again or operate lever 1 to return to idle speed.



## 12 - GEAR RATIO LIMITER

### ⚠ IMPORTANT ⚠





*BE CAREFUL when using the gear ratio limiter while driving.*



*As soon as  appears on the information screen, selecting the gear ratio with button A will act directly on*

*the lift truck and may cause it to decelerate sharply.  
Always reduce speed before use.*

#### GEAR RATIO LIMITER USE AND MEMORIZATION

- Turn the navigation knob A to select driving mode .
- Press knob A or press and hold the ;  will appear on the information screen.
- Turn knob A to select the gear ratio.
- Press knob A to confirm and save.
- The memorized gear ratio will be displayed on the information screen .

#### ACTIVATING THE MEMORIZED GEAR RATIO

- Press the  button to activate. The indicator light will come on, showing that it is in use.
- Press the button again to deactivate.
- Press the button again to deactivate.



### 13 - "ECO STOP" ENGINE

This function can take charge of engine shutdown to reduce consumption. It can be used if all of the following conditions are met within a time period defined by the operator.

- Engine running.
- Engine speed less than 1,000 rpm.
- No driver presence.
- No manual override in progress.
- No "stationary lift truck" exhaust regeneration.
- Parking brake applied.
- Engine coolant temperature higher than 40 °C.

#### TIME DELAY ADJUSTMENT

- Press button B to display the "PREFERENCES" menu
- Turn knob A to navigate through the menus and sub-menus.

ENGINE SPECIFICATION > ECO STOP

- Select the time delay (between 1 and 20 minutes) and press knob A to confirm.

#### OPERATION

- Press the  button to activate. The indicator light will come on, showing that it is in use.

NOTE: To restart the engine, turn the ignition key to position O.

#### **⚠ IMPORTANT ⚠**

*The "ECO STOP" function does not under any circumstances replace lift truck shutdown. You must shut down the lift truck at the end of the job or the end of the day (⚠ 1 - OPERATING AND SAFETY INSTRUCTIONS: OPERATOR INSTRUCTIONS: OPERATING INSTRUCTIONS WITH AND WITHOUT LOAD: G - STOPPING THE LIFT TRUCK).*



### 14 - EXTERIOR DRAIN-BACK

Enables connection of a hydraulic attachment for which drain-back is required.



## 15 - ATTACHMENT EASY HYDRAULIC CONNECTION

For easy connection and disconnection of hydraulic attachments.

### PUSH BUTTON OPERATION

- Switch on lift truck ignition.
- Press for two seconds on pushbutton 1 to release the attachment circuit hydraulic pressure.
- Connect or disconnect the quick couplers of the hydraulic attachment (<math>\leq 4</math> - ADAPTABLE ATTACHMENTS AS AN OPTION ON THE RANGE: PICKING UP THE ATTACHMENTS).



### NAVIGATION BUTTON OPERATION

- Switch on lift truck ignition.
- Press button B to display the "PREFERENCES" menu
- Turn knob A to navigate through the menus and sub-menus.

HYDRAULICS > EASY CONNECT SYSTEM

- Press knob A to confirm.
- Connect or disconnect the quick couplers of the hydraulic attachment (<math>\leq 4</math> - ADAPTABLE ATTACHMENTS AS AN OPTION ON THE RANGE: PICKING UP THE ATTACHMENTS).



## 16 - HYDRAULIC ATTACHMENT LOCKING

Enables the attachment to be locked onto the carriage and a hydraulic attachment to be used by the same circuit.

### ⚠ IMPORTANT ⚠

Once the attachment is locked, return valve 1 to position B to prevent accidental release of the attachment.  
OR

Press the button  to shut off the attachment circuit hydraulic movements. The indicator lamp indicates it is in use.

### ATTACHMENT LOCKING CONTROL

- Set valve 1 to position A.
- Push switch 2 forward to lock the attachment and backward to release it.
- Set valve 1 to position B.

### HYDRAULIC ATTACHMENT CONTROL

- Set valve 1 to position B.
- Push switch 2 forward or backward.

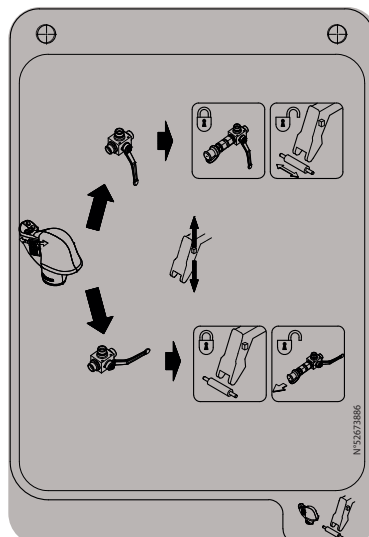
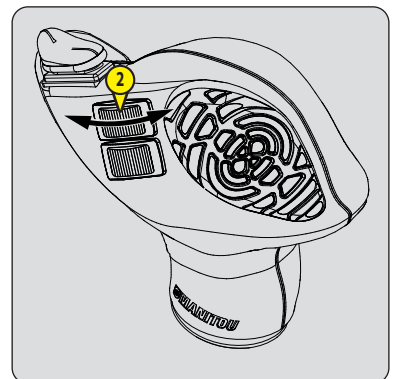
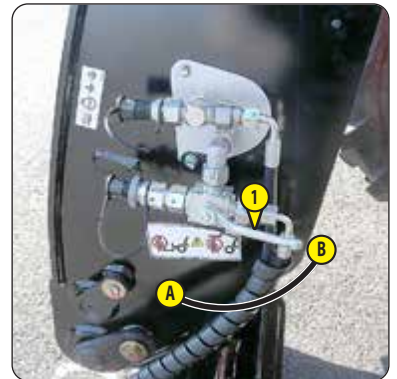

## 17 - BOOM HEAD ELECTROVALVE

Enables use of two hydraulic functions on the attachment circuit.

NOTE: For ease of connection of the quick-release couplers, decompress the hydraulic circuit by pressing button 1 on the electrovalve.

### ATTACHMENT LINE CONTROL "C1-C4"

- Turn off the  switch (indicator lamp off).
- Push switch 2 forward or backward to control the attachment line "C1-C4".

### ATTACHMENT LINE CONTROL "C1-C4 / C2-C3"

- Turn on the  switch (indicator lamp on).
- Push switch 2 forward or backward to control the attachment line "C1-C4".
- Hold down button 3 and push switch 2 forward or backward to control the attachment line "C2-C3".

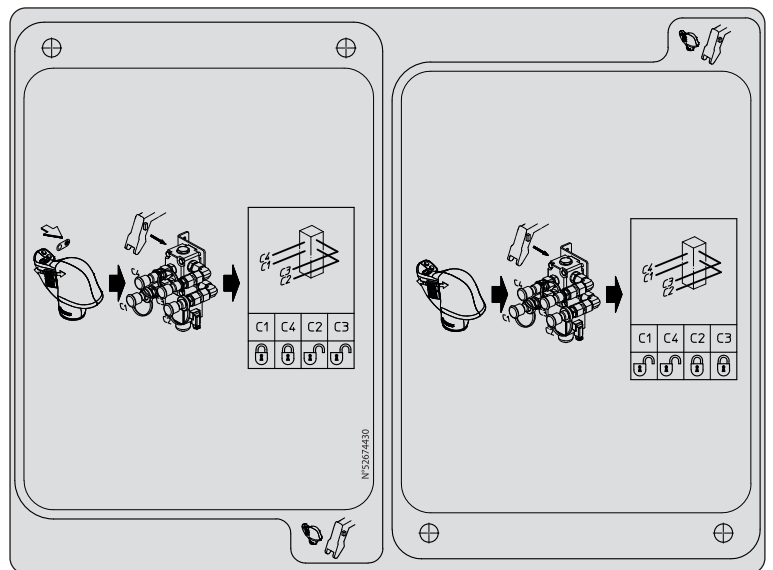
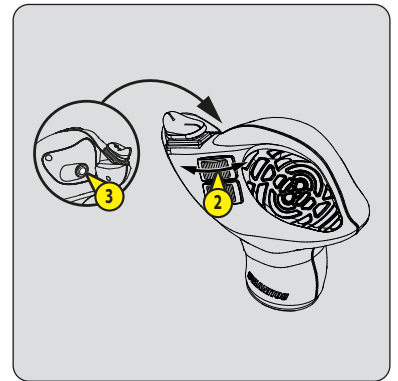
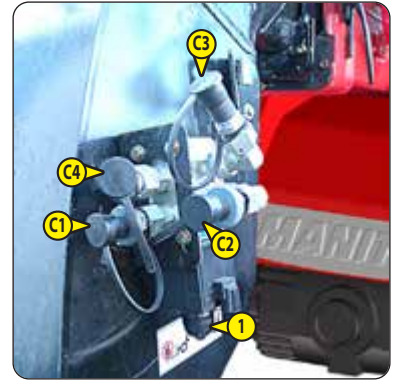

## 18 - BOOM HEAD ELECTROVALVE + HYDRAULIC ATTACHMENT LOCKING

The addition of these two options on the attachment line allows two hydraulic functions to be used and locks the attachment onto the carriage.

NOTE: For ease of connection of the quick-release couplers, decompress the hydraulic circuit by pressing button 1 on the electrovalve.

### ⚠ IMPORTANT ⚠

*Once the attachment is locked, return valve 2 to position B to prevent accidental release of the attachment.*

#### ATTACHMENT LINE CONTROL "C1-C4"

- Turn off the  switch (indicator lamp off).
- Push switch 3 forward or backward to control the attachment line "C1-C4".

#### ATTACHMENT LINE CONTROL "C1-C4 / C2-C3" + HYDRAULIC ATTACHMENT LOCKING

- Turn on the  switch (indicator lamp on).
- Set valve 2 to position B.
- Push switch 3 forward or backward to control the attachment line "C1-C4".
- Hold down button 4 and push switch 3 forward or backward to control the attachment line "C2-C3".

#### LOCKING AN ATTACHMENT

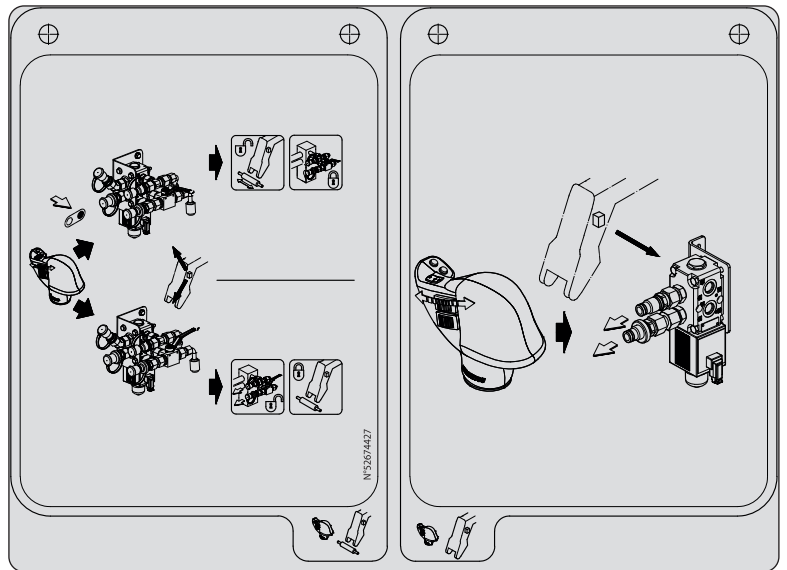
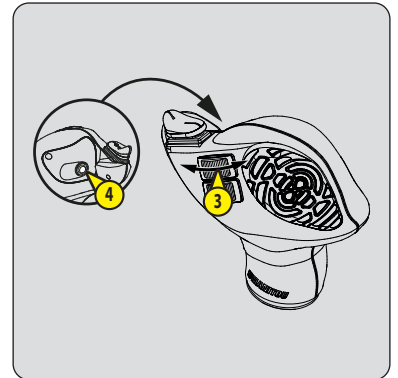
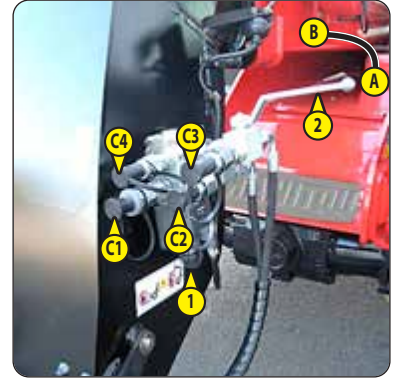

- Turn on the  switch (indicator lamp on).
- Set valve 2 to position A.
- Hold down button 4 and push button 3 forward to lock the attachment and backward to release it.
- Set valve 2 to position B.



## 19 - ATTACHMENT CIRCUIT FLOW RATE LIMITER

### FLOW RATE MEMORIZATION

- Hold down the  button,  will appear on the information screen.

NOTE: Depending on the OPTIONS, you can have two attachment circuits  . Press button B to select the second circuit.

- Turn knob A to limit the flow rate to a value of your choice.
- Press knob A to confirm and proceed to the adjustment of the other line.
- Press knob A again to confirm and exit the setting menu.



### ACTIVATING THE MEMORIZED FLOW RATE



- Press the  button to activate. The indicator light will come on, showing that it is in use.
- Press the button again to deactivate.



## 20 - ATTACHMENT CIRCUIT MANUAL OVERRIDE

### ⚠ IMPORTANT ⚠

*This OPTION must only be used with an attachment requiring continuous hydraulic movement, such as a brush, feeder bucket, mixer, spray etc. It is strictly forbidden for use in handling operations and all other applications (winch, crane jib, crane jib with winch, hook, etc.).*



### USING AND STORING MANUAL OVERRIDE

- Turn the navigation knob A to select work mode .
- Press knob A or press and hold the ;  will appear on the information screen.

NOTE: Depending on the OPTIONS, you can have two attachment circuits  . Press button B to select the second circuit.

- Turn the knob A to select the line.
- Confirm by pressing knob A.
- Turn knob A to set the desired flow rate.
- Press knob A to confirm and save.

### ACTIVATING THE STORED MANUAL OVERRIDE

- Press the  button to activate manual override.
- Confirm by pressing the  button a second time or pressing knob A.
- Press the  button again to deactivate.

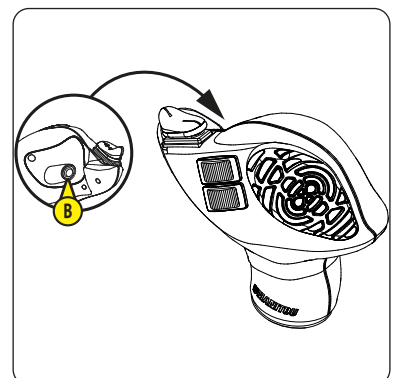

## 21 - BOOM SUSPENSION

The boom suspension dampens shaking of the lift truck on rough ground (e.g. handling straw in a field).

### ⚠ IMPORTANT ⚠

*When you make a hydraulic downward or tilting movement, boom suspension is temporarily disabled and the button's*

*indicator light  goes off.  
Boom suspension is active from 5 km/h.*

- Press the  button to activate. The indicator light will come on, showing that it is in use.
- Press the button again to deactivate.
- When the engine is off, boom suspension is automatically deactivated.

NOTE: Forced boom suspension  allows it to be used below 5 km/h.



## 22 - "INTELLIGENT HYDRAULICS" FUNCTIONS

Hydraulic functions can be combined in order to optimize repetitive movement cycles (e.g. loading material in a dump truck).

### QUICK LIFT "QUICKLIFT"

Optimizes the cycle times by combining telescope raising/extension and lowering/retraction hydraulic movements.

The load offset is adjustable within a horizontal range of  $\pm 50$  cm, beyond this offset, the "Quicklift" function is no longer operational. Push switch B backward to retract the telescope and recover the function.

- Place the lift truck in the transport position.
- Press the  button to activate. The indicator light will come on, showing that it is in use.
- Pull lever A backwards to perform combined lifting and extension.
- Push lever A forwards to perform combined lowering and retraction.

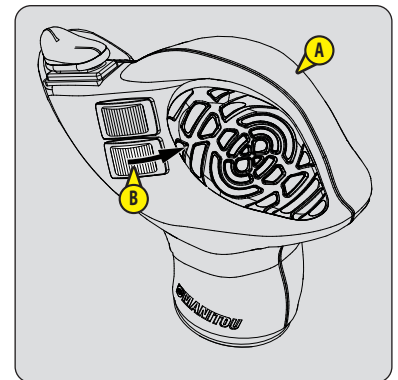

### BUCKET SHAKING "BUCKET SHAKER"

Performs a bucket shaking sequence when the tilt-down instruction is maintained. Maximum shaking intensity is obtained at an engine speed of approx. 1,600 rpm.

- Press the  button to activate. The indicator light will come on, showing that it is in use.
- Push and hold lever A fully to the right to tilt down and shake the bucket.

### LOADING POSITION RETURN "RETURN TO LOAD"

Returns the bucket to the loading position (e.g. Loading a trailer).

- Place the lift truck in the transport position.
- Place the bucket in the loading position.
- Press the  button to save the position. The indicator lamp will show it is in use.
- Fill and tilt up the bucket into the transport position.
- Empty the bucket into the trailer.
- Tilt up the bucket and reverse the lift truck.
- Push lever A fully forward to return the bucket to the loading position.

## 23 - SEMI-AUTOMATIC WHEEL ALIGNMENT

### ⚠ IMPORTANT ⚠

*Check the alignment of the front and rear wheels each time the lift truck is started.*

*Regularly check the alignment of the wheels when using the lift truck.*

*The wheels must be aligned and the lift truck must be in front steering wheels mode when used on public roads.*

*A green light illuminates on the dashboard when the wheels are aligned.*

*It is not possible to change the steering mode above 11 km/h.*

*Contact your dealer if you have any questions.*



### CHANGING THE STEERING MODE



Front steering wheels (road mode).



Front and rear steering wheels in opposite directions (short steering).



Front and rear steering drive wheels in the same direction (crab steering).



Front steering wheels and locking of the rear wheel steering angle.

- Align the rear and front wheels.
- Select the desired steering mode, a flashing indicator lamp will confirm the selection.
- Turn the wheels as instructed on the information screen. The indicator lamp will remain steadily lit while the steering mode is enabled.

## 24 - "COMFORT STEERING SYSTEM"

The function enables the wheels to be turned in a single turn of the steering wheel.

The number of turns of the steering when increases proportionally with the speed of travel of the lift truck and/or the boom lifting angle.

### OPERATION



- Press switch 1 the indicator  will come on when the function is enabled.

NOTE: The function is disabled when the speed exceed 15 km/h.



## 25 - DOUBLE-ACTING REAR HYDRAULIC CONTROL PREDISPOSITION

Enables the use of a hydraulic attachment at the rear of the lift truck (e.g. a trailer with hydraulic tipping).

### DOUBLE-ACTING REAR HYDRAULIC CONTROL "L1-L2"

- Select the rear attachment hydraulic line .
- Push switch 1 forward or backward.

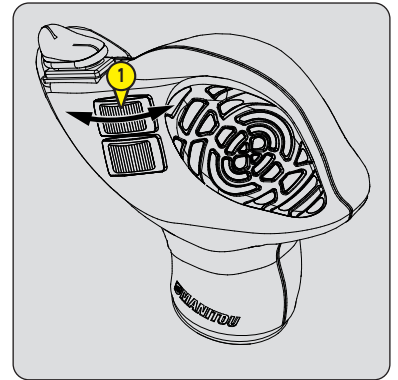
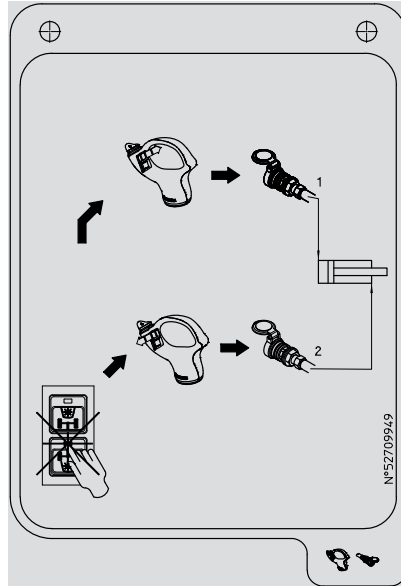

**26 - TWO DOUBLE-ACTING REAR HYDRAULIC CONTROL PREDISPOSITIONS**

Enables two hydraulic circuits at the rear of the lift truck to be selected for use.

**DOUBLE-ACTING REAR HYDRAULIC CONTROL "L1-L2"**

- Select the rear attachment hydraulic line 
- Push switch 1 forward or backward.

**DOUBLE-ACTING REAR HYDRAULIC CONTROL "L3-L4"**

- Select the rear attachment hydraulic line 
- Hold down button 2 and operate button 1 forwards or backwards.

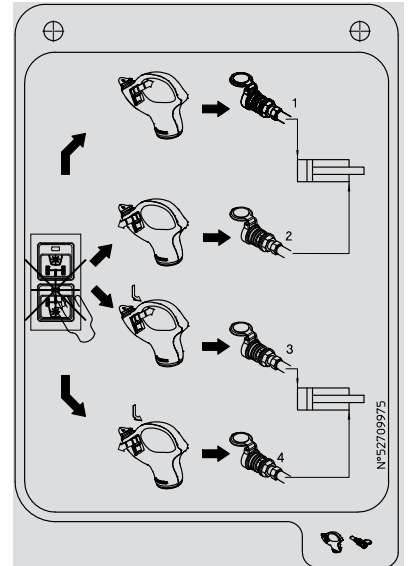
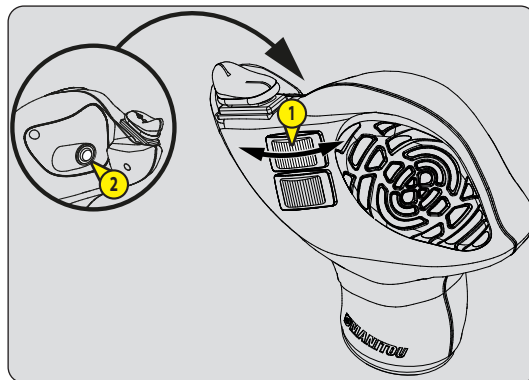

**27 - HYDRAULIC TRAILER HOOK + DOUBLE-ACTING REAR HYDRAULIC CONTROL PREDISPOSITION**

Enables use of the towing hook (TOWING DEVICE) or a hydraulic attachment at the rear of the lift truck.

**DOUBLE-ACTING REAR HYDRAULIC CONTROL "L1-L2"**

- Select the rear attachment hydraulic line 
- Push switch 1 forward or backward.

**HYDRAULIC TOWING HOOK "L3-L4"**

- Select the rear attachment hydraulic line 
- Hold down button 2 and operate button 1 forwards or backwards.

TOWING PIN AND HOOK

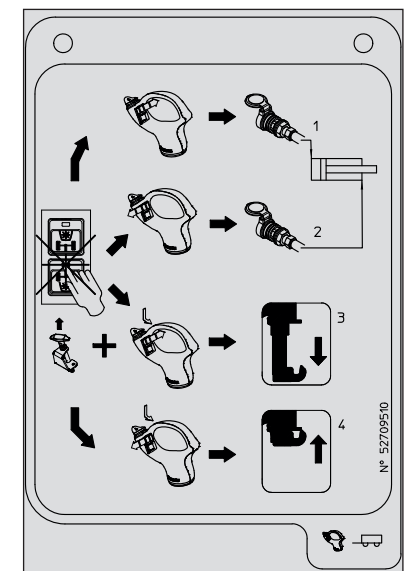
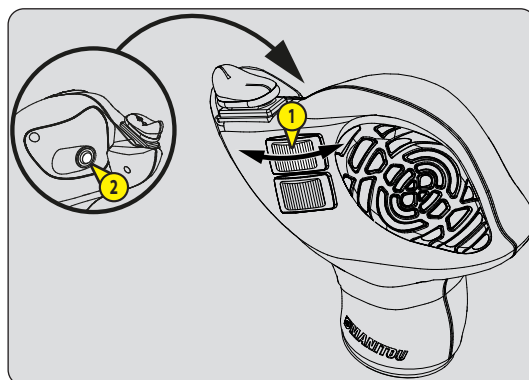



# ***3 - MAINTENANCE***

### 3 - MAINTENANCE

<b>ORIGINAL MANITOU SPARE PARTS AND EQUIPMENT</b>	<b>3-3</b>
<b>FORKLIFT TRUCK MAINTENANCE</b>	<b>3-4</b>
<b>DAILY AND WEEKLY MAINTENANCE</b>	<b>3-4</b>
<b>MANDATORY FIRST 500 HOURS OR 6 MONTHS OF SERVICE</b>	<b>3-5</b>
<b>PERIODIC MAINTENANCE</b>	<b>3-6</b>
<b>OCCASIONAL MAINTENANCE AND OPERATION</b>	<b>3-8</b>
<b>FILTER CARTRIDGES AND BELTS</b>	<b>3-8</b>
<b>LUBRICANTS AND FUEL</b>	<b>3-10</b>
<b>➔ 10H - DAILY SERVICE OR EVERY 10 HOURS OF SERVICE</b>	<b>3-14</b>
<b>➔ 50H - WEEKLY SERVICE OR EVERY 50 HOURS OF OPERATION</b>	<b>3-16</b>
<b>➔ ① 500H - PERIODIC MAINTENANCE - EVERY 500 HOURS OF SERVICE OR 1 YEAR</b>	<b>3-20</b>
<b>➔ ② 1000H - PERIODIC MAINTENANCE - EVERY 1,000 HOURS OF SERVICE OR EVERY 2 YEARS</b>	<b>3-22</b>
<b>➔ ③ 2000H - PERIODIC MAINTENANCE - EVERY 2,000 HOURS OF SERVICE OR EVERY 4 YEARS</b>	<b>3-30</b>
<b>➔ ④ 3000H - PERIODIC MAINTENANCE - EVERY 3,000 HOURS OF SERVICE OR EVERY 6 YEARS</b>	<b>3-32</b>
<b>➔ ⑤ 4500H - PERIODIC MAINTENANCE - EVERY 4,500 HOURS OF SERVICE OR EVERY 9 YEARS</b>	<b>3-33</b>
<b>➔ ⑥ 6000H - PERIODIC MAINTENANCE - EVERY 6,000 HOURS OF SERVICE OR 12 YEARS</b>	<b>3-33</b>
<b>➔ ⑦ 9000H - PERIODIC MAINTENANCE - EVERY 9,000 HOURS OF SERVICE OR 18 YEARS</b>	<b>3-33</b>
<b>➔ OCCASIONAL SERVICING</b>	<b>3-34</b>
<b>➔ OCCASIONAL OPERATION</b>	<b>3-36</b>

## ORIGINAL MANITOU SPARE PARTS AND EQUIPMENT

OUR LIFT TRUCKS MUST BE SERVICED USING ORIGINAL MANITOU PARTS.

### **BY ALLOWING THE USE OF NON ORIGINAL MANITOU PARTS, YOU RISK:**

#### **⚠ IMPORTANT ⚠**

**THE USE OF NON-OEM PARTS OR COMPONENTS NOT APPROVED BY THE MANUFACTURER, MEANS YOU LOSE THE BENEFIT OF THE CONTRACTUAL GUARANTEE.**

- Legally - to incur liability in the event of an accident.
- Technically - to cause operating malfunctions or shorten the life of the lift truck.

### **BY USING ORIGINAL MANITOU PARTS FOR MAINTENANCE OPERATIONS, YOU BENEFIT FROM OUR KNOW-HOW**

Through its network, MANITOU provides the user with,

- Know-how and competence.
- The guarantee of high-quality work.
- Original replacement parts.
- Help with preventive maintenance.
- Efficient help with diagnosis.
- Improvements due to experience feedback.
- Operator training.
- Only the MANITOU network has detailed knowledge of the design of the lift truck and therefore the best technical ability to provide maintenance.

#### **⚠ IMPORTANT ⚠**

**ORIGINAL REPLACEMENT PARTS ARE DISTRIBUTED EXCLUSIVELY BY MANITOU AND ITS DEALER NETWORK.**

*The dealer network list is available on the MANITOU web site: [www.manitou.com](http://www.manitou.com)*

## FORKLIFT TRUCK MAINTENANCE

### DAILY AND WEEKLY MAINTENANCE



**THE OPERATOR IS AUTHORISED TO CARRY OUT THIS MAINTENANCE.**

These maintenance operations enable the operator to maintain the lift truck in a clean and safe condition.

### MANDATORY FIRST 500 HOURS OR 6 MONTHS OF SERVICE



**THIS SERVICE MUST BE CARRIED OUT AFTER THE FIRST 500 HOURS OF SERVICE OR WITHIN THE 6 MONTHS FOLLOWING PUTTING THE MACHINE INTO SERVICE (WHICHEVER OCCURS FIRST).**

### PERIODIC MAINTENANCE



**THE PERIODIC MAINTENANCE MUST BE CARRIED OUT BY AN APPROVED PROFESSIONAL FROM THE MANITOU NETWORK.**

### MAINTENANCE SCHEDULE

This schedule enables the operator to keep up with the periodic maintenance of the lift truck by notifying the total number of hours of operation and the date of the service performed by the professional approved by the MANITOU network.

### OCCASIONAL MAINTENANCE AND OPERATION

These maintenance tasks and operations are to be performed as required for the safety and upkeep of the lift truck.

## DAILY AND WEEKLY MAINTENANCE

### 🔄 10H - DAILY SERVICE OR EVERY 10 HOURS OF SERVICE

- CHECK	Lift truck environment .....	3-14
- CHECK	Engine oil level.....	3-14
- CHECK	Coolant level.....	3-14
- CHECK	Fuel pre-filter .....	3-15
- CHECK	Greasing unit level (OPTION) .....	3-15

### 🔄 50H - WEEKLY SERVICE OR EVERY 50 HOURS OF OPERATION

- CHECK	Gear box oil level.....	3-16
- CHECK	Tire pressure.....	3-16
- CHECK	Wheel nut torque .....	3-16
- CHECK	Front axle differential seal .....	3-16
- CHECK	Rear axle differential seal .....	3-16
- CHECK	Front wheel reducer seals .....	3-16
- CHECK	Rear wheel reducer seals .....	3-16
- CHECK	Boom pad slide pathways .....	3-17
- CHECK	Hydraulic fluid level.....	3-17
- CHECK	Windshield washer fluid level.....	3-18
- CLEAN	Radiator harness .....	3-18
- CLEAN	Condenser harness (Air conditioning OPTION) .....	3-18
- CHECK	Parking brake efficiency.....	3-18
- LUBRICATE	General lubrication .....	3-19

## MANDATORY FIRST 500 HOURS OR 6 MONTHS OF SERVICE

### FIRST 500 HOURS BEFORE THE FIRST 6 MONTHS

- If the lift truck has reached the first 500 hours of operation before the first 6 months have expired, perform both the mandatory maintenance and periodic 500 H maintenance (◀ ➡ ① 500H - PERIODIC MAINTENANCE - EVERY 500 HOURS OF SERVICE OR 1 YEAR)

### FIRST 6 MONTHS BEFORE THE FIRST 500 HOURS

- If the lift truck has not completed 500 hours of service in the first 6 months, just carry out the mandatory service.

## ➡ MANDATORY SERVICE

- CHECK	Gear box oil level.....	3-16
- CHECK	Tire pressure.....	3-16
- CHECK	Wheel nut torque.....	3-16
- CHECK	Front axle differential seal.....	3-16
- CHECK	Rear axle differential seal.....	3-16
- CHECK	Front wheel reducer seals.....	3-16
- CHECK	Rear wheel reducer seals.....	3-16
- CHECK	Boom pad slide pathways.....	3-17
- CHECK	Hydraulic fluid level.....	3-17
- CHECK	Windshield washer fluid level.....	3-18
- CLEAN	Radiator harness.....	3-18
- CLEAN	Condenser harness (Air conditioning OPTION).....	3-18
- LUBRICATE	General lubrication.....	3-19
- CHECK	Fork wear *.....	3-21
- ADJUST	Service brake and parking brake *.....	3-21
- CHECK	Seat belt.....	3-22
- CHECK	Engine silent blocks *.....	3-29
- CHECK/ADJUST	Intake **.....	3-29
- CHECK	Flexible pipes and hoses **.....	3-29
- CHECK	Gearbox silent blocks *.....	3-29
- CHECK	Brake system pressure *.....	3-29
- CHECK	Boom pad wear *.....	3-29
- CHECK	Condition of wiring harnesses and cables *.....	3-29
- CHECK	Lights and signals *.....	3-29
- CHECK	Warning indicators *.....	3-29
- CHECK	Condition of the rear view mirrors *.....	3-29
- CHECK	Cab structure *.....	3-29
- CHECK	Chassis structure *.....	3-29
- CHECK	Attachment mounting system *.....	3-29
- CHECK	Condition of attachments *.....	3-29

**\*\* Engine service, consult your dealer.**

**\* Consult your dealer.**

# PERIODIC MAINTENANCE

## MAINTENANCE SCHEDULE

WHEN DUE →	↕ OR ↕		500 H or 1 YEAR	1000 H or 2 YEARS	1500 H or 3 YEARS	2000 H or 4 YEARS
	FIRST 6 MONTHS	FIRST 500 HOURS				
PERIODIC MAINTENANCE →	MANDATORY SERVICE	MANDATORY SERVICE + ①	①	①+②	①	①+②+③
MACHINE COUNTER →						
DATE OF SERVICING →						

WHEN DUE →	2500 H or 5 YEARS	3000 H or 6 YEARS	3500 H or 7 YEARS	4000 H or 8 YEARS	4500 H or 9 YEARS	5000 H or 10 YEARS	5500 H or 11 YEARS
PERIODIC MAINTENANCE →	①	①+②+④	①	①+②+③	①+⑤	①+②	①
MACHINE COUNTER →							
DATE OF SERVICING →							

WHEN DUE →	6000 H or 12 YEARS	6500 H or 13 YEARS	7000 H or 14 YEARS	7500 H or 15 YEARS	8000 H or 16 YEARS	8500 H or 17 YEARS	9000 H or 18 YEARS
PERIODIC MAINTENANCE →	①+②+③+④+⑥	①	①+②	①	①+②+③	①	①+②+④+⑤+⑦
MACHINE COUNTER →							
DATE OF SERVICING →							

### ➔ ① 500H - PERIODIC MAINTENANCE - EVERY 500 HOURS OF SERVICE OR 1 YEAR

- CHECK	Hydraulic fluid .....	3-20
- REPLACE	Front axle differential oil .....	3-20
- REPLACE	Rear axle differential oil .....	3-20
- REPLACE	Cab ventilation filters .....	3-21
- REPLACE	Filter coupling (OPTIONAL Automatic central greasing).....	3-21
- CHECK	Fork wear * .....	3-21
- ADJUST	Service brake and parking brake * .....	3-21

\* Consult your dealer.

### ➔ ② 1000H - PERIODIC MAINTENANCE - EVERY 1,000 HOURS OF SERVICE OR EVERY 2 YEARS

ALSO CARRY OUT THE PERIODIC MAINTENANCE FOR 500 HOURS OF SERVICE.

- CHECK	Seat belt .....	3-22
- REPLACE	Engine oil .....	3-22
- REPLACE	Engine oil filter .....	3-22
- CLEAN	Fuel tank .....	3-23
- REPLACE	Fuel tank breather .....	3-23
- REPLACE	Fuel pre-filter .....	3-23
- REPLACE	Fuel filter .....	3-24
- REPLACE	Coolant .....	3-24
- REPLACE	Dry air filter cartridge .....	3-25
- REPLACE	"DEF" (Diesel Exhaust Fluid) supply pump filter .....	3-26
- REPLACE	Tank breather "DEF" (diesel exhaust fluid) .....	3-26
- REPLACE	Gearbox oil .....	3-27
- REPLACE	Gear box oil filter .....	3-27
- REPLACE	Front wheel reducer oil .....	3-28
- REPLACE	Rear wheel reducer oil .....	3-28
- REPLACE	Hydraulic return oil filter cartridge .....	3-28

- REPLACE	Pressure hydraulic oil filter cartridge	3-28
- CHECK	Engine silent blocks *	3-29
- CHECK/ADJUST	Intake **	3-29
- CHECK	Flexible pipes and hoses **	3-29
- CHECK	Gearbox silent blocks *	3-29
- CHECK	Brake system pressure *	3-29
- CHECK	Boom pad wear *	3-29
- CHECK	Condition of wiring harnesses and cables *	3-29
- CHECK	Lights and signals *	3-29
- CHECK	Warning indicators *	3-29
- CHECK	Condition of the rear view mirrors *	3-29
- CHECK	Cab structure *	3-29
- CHECK	Chassis structure *	3-29
- CHECK	Attachment mounting system *	3-29
- CHECK	Condition of attachments *	3-29

**\*\* Engine service, consult your dealer.**

**\* Consult your dealer.**

### ➔ ③ 2000H - PERIODIC MAINTENANCE - EVERY 2,000 HOURS OF SERVICE OR EVERY 4 YEARS

**ALSO PERFORM THE 500-HOUR AND 1,000-HOUR PERIODIC MAINTENANCE PROCEDURES.**

- CHECK	Wheel nut tightening torque	3-30
- REPLACE	Dry air filter safety cartridge	3-30
- REPLACE	Hydraulic fluid	3-30
- CLEAN	Hydraulic fluid tank suction strainers	3-30
- CHECK	Radiator *	3-31
- CHECK	Transmission pressures *	3-31
- CHECK	Gearbox calibration *	3-31
- CHECK	Steering *	3-31
- CHECK	Steering swivel joints *	3-31
- CHECK	Condition of boom assembly *	3-31
- CHECK	Bearings and bushings *	3-31
- CHECK	Condition of hoses and flexible pipes *	3-31
- CHECK	Condition of cylinders (leakage, rods) *	3-31
- CHECK	Hydraulic circuit pressures *	3-31
- CHECK	Bearings and bushings *	3-31
- CLEAN	Air conditioning (OPTION) *	3-31

**\* Consult your dealer.**

### ➔ ④ 3000H - PERIODIC MAINTENANCE - EVERY 3,000 HOURS OF SERVICE OR EVERY 6 YEARS

**ALSO PERFORM THE 500-HOUR AND 1,000-HOUR PERIODIC MAINTENANCE PROCEDURES.**

- REPLACE	Alternator belt	3-32
-----------	-----------------	------

### ➔ ⑤ 4500H - PERIODIC MAINTENANCE - EVERY 4,500 HOURS OF SERVICE OR EVERY 9 YEARS

**ALSO CARRY OUT THE PERIODIC MAINTENANCE FOR 500 HOURS OF SERVICE.**

- CHECK	Engine crankcase breather	3-33
- REPLACE	Engine breather crankcase filter	3-33
- CHECK	ECU and associated sensors and actuators **	3-33
- CHECK	Turbocharger **	3-33
- CHECK/CLEAN	(EGR) Exhaust gas recirculation system valve **	3-33
- CHECK	Selective catalytic reduction (SCR) / Diesel oxidation catalyst (DOC) **	3-33
- CHECK/CLEAN	Injector **	3-33

**\*\* Engine service, consult your dealer.**

### ➔ ⑥ 6000H - PERIODIC MAINTENANCE - EVERY 6,000 HOURS OF SERVICE OR 12 YEARS

**ALSO PERFORM THE PERIODIC MAINTENANCE AT 500 HOURS, 1,000 HOURS, 2,000 HOURS AND 3,000 HOURS OF SERVICE.**

- CHECK	Diesel Particulate Filter (DPF) **	3-33
---------	------------------------------------	------

**\*\* Engine service, consult your dealer.**

### ➔ ⑦ 9000H - PERIODIC MAINTENANCE - EVERY 9,000 HOURS OF SERVICE OR 18 YEARS

**ALSO PERFORM THE PERIODIC MAINTENANCE AT 500 HOURS, 1,000 HOURS, 3,000 HOURS AND 4,500 HOURS OF SERVICE.**

- REPLACE	Diesel Particulate Filter (DPF) **	3-33
- REPLACE	Selective catalytic reduction (SCR) **	3-33

**\*\* Engine service, consult your dealer.**

## OCCASIONAL MAINTENANCE AND OPERATION

### OCCASIONAL SERVICING

- CLEAN	"Stationary lift truck" exhaust regeneration" .....	3-34
- REPLACE	Wheels .....	3-34
- REPLACE	Battery .....	3-35
- ADJUST	Front headlights .....	3-35

### OCCASIONAL OPERATION

- TOW OR WINCH	Lift truck .....	3-36
- SLING	Lift truck .....	3-37
- TRANSPORT	Lift truck .....	3-38

## FILTER CARTRIDGES AND BELTS

### 1 500H - PERIODIC MAINTENANCE - EVERY 500 HOURS OF SERVICE OR 1 YEAR

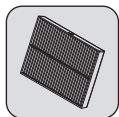

INTERIOR CAB VENTILATION FILTER  
Part No.: 52543388



FILTER COUPLING  
(AUTOMATIC CENTRAL GREASING OPTION)  
Part No.: 52654729

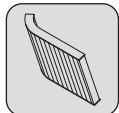

EXTERIOR CAB VENTILATION FILTER  
Part No.: 958671

### 2 1000H - PERIODIC MAINTENANCE - EVERY 1,000 HOURS OF SERVICE OR EVERY 2 YEARS

ALSO ADD THE FILTER CARTRIDGES FROM THE PERIODIC MAINTENANCE FOR 500 HOURS OF SERVICE.

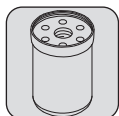

ENGINE OIL FILTER  
Part No.: 964294

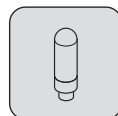

TANK BREATHER "DEF" (Diesel Exhaust Fluid)  
Part No.: 960341



FUEL FILTER  
Part No.: 964303

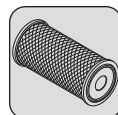

DRY AIR FILTER CARTRIDGE  
Part No.: 52686670

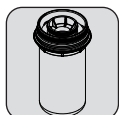

FUEL PRE-FILTER  
Part No.: 52708330

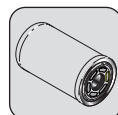

GEARBOX OIL FILTER  
Part No.: 745878



FUEL TANK BREATHER  
Part No.: 266219

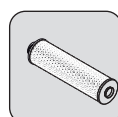

HYDRAULIC RETURN OIL FILTER CARTRIDGE  
Part No.: 282526



DEF (Diesel Exhaust Fluid) FEED PUMP FILTER  
Part No.: 941976

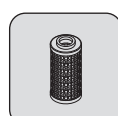

PRESSURE HYDRAULIC OIL FILTER CARTRIDGE  
Part No.: 518251

### ➔ ③ 2000H - PERIODIC MAINTENANCE - EVERY 2,000 HOURS OF SERVICE OR EVERY 4 YEARS

---

**ALSO ADD FILTER ELEMENTS FOR PERIODIC MAINTENANCE AT 500 HOURS AND 1,000 HOURS OF SERVICE.**

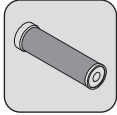

SAFETY DRY AIR FILTER CARTRIDGE  
Part No.: 52686672

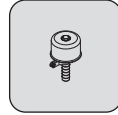

BREATHER FOR THE HYDRAULIC OIL TANK  
Part No.: 278288

### ➔ ④ 3000H - PERIODIC MAINTENANCE - EVERY 3,000 HOURS OF SERVICE OR EVERY 6 YEARS

---

**ALSO ADD FILTER ELEMENTS FOR PERIODIC MAINTENANCE AT 500 HOURS AND 1,000 HOURS OF SERVICE.**



ALTERNATOR BELT  
Part No.: 964292

### ➔ ⑤ 4500H - PERIODIC MAINTENANCE - EVERY 4,500 HOURS OF SERVICE OR EVERY 9 YEARS

---

**ALSO ADD THE FILTER CARTRIDGES FROM THE PERIODIC MAINTENANCE FOR 500 HOURS OF SERVICE.**

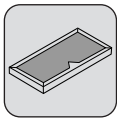

ENGINE BREATHER CRANKCASE FILTER  
Part No.: 52715195

### ➔ OCCASIONAL SERVICING

---



COMPRESSOR BELT  
(AIR CONDITIONING OPTION)  
Part No.: 319790

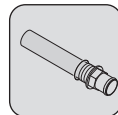

SUCTION STRAINER FOR HYDRAULIC FLUID  
TANK  
Part No.: 52522593



SELF-CLEANING PRE-FILTER  
Part No.: 226611

## LUBRICANTS AND FUEL

### ⚠ IMPORTANT ⚠

USE THE RECOMMENDED LUBRICANTS AND FUEL:

- For topping up, oils may not be miscible.
- For oil changes, MANITOU oils are perfectly appropriate.

### DIAGNOSTIC ANALYSIS OF OILS

If a service or maintenance contract has been set up with the dealer, a diagnostic analysis of engine, transmission and axle oils may be requested depending on the rate of use.

#### (\*) REQUIRED FUEL SPECIFICATION

Use a high-quality fuel to obtain optimal performance of the engine.

- Type of diesel fuel EN590 (sulfur content < 10 ppm)
- Type of diesel fuel ASTM D975 (sulfur content < 15 ppm)
- Biodiesel B8 to B20 EN16709
- Biodiesel HVO100 EN15940

#### (\*\*) SPECIFICATION "DEF" (Diesel Exhaust Fluid)

- Aqueous urea solution at 32.5% (ISO22241)
- Solidification at -11 °C and 10% expansion
- Non-flammable product
- Thermal degradation (>60 °C)
- Storage between -5 °C and 30 °C

### ⚠ IMPORTANT ⚠

Corrosive to metals, requires wearing personal protection (gloves and goggles).

## RECOMMENDATION

ENGINE		RECOMMENDATION									
DESCRIPTION	CAPACITY	-40 °F	-22	-4	+14	+32	+50	+68	+86	+104	+122 °F
		-40 °C	-30	-20	-10	0	+10	+20	+30	+40	+50 °C
ENGINE	19.02 US qt (18 L)	SAE 5W30									
		SAE 10W30									
		MANITOU EVOLOGY OIL 10W40 API CJ4									
		SAE 10W40									
		SAE 15W40									
		-40 °F	-22	-4	+14	+32	+50	+68	+86	+104	+122 °F
		-40 °C	-30	-20	-10	0	+10	+20	+30	+40	+50 °C
COOLING CIRCUIT	22.19 US qt (21 L)	COOLANT -35 °C									
		-40 °F	-22	-4	+14	+32	+50	+68	+86	+104	+122 °F
		-40 °C	-30	-20	-10	0	+10	+20	+30	+40	+50 °C
FUEL TANK	150.05 US qt (142 L)	HP NON-ROAD DIESEL (GNR) *									
"DEF" TANK (Diesel Exhaust Fluid)	22.19 US qt (21 L)	DEF **									
TRANSMISSION		RECOMMENDATION									
DESCRIPTION	CAPACITY	-40 °F	-22	-4	+14	+32	+50	+68	+86	+104	+122 °F
		-40 °C	-30	-20	-10	0	+10	+20	+30	+40	+50 °C
GEARBOX	22.19 US qt (21 L)	MANITOU DX III G AUTOMATIC TRANSMISSION OIL									

<b>BOOM</b>												
DESCRIPTION		RECOMMENDATION										
		-40 °F	-22	-4	+14	+32	+50	+68	+86	+104	+122 °F	
		-40 °C	-30	-20	-10	0	+10	+20	+30	+40	+50 °C	
BOOM PAD SLIDE PATHWAYS		MANITOU BLACK MULTI-PURPOSE LUBRICANT										
		-40 °F	-22	-4	+14	+32	+50	+68	+86	+104	+122 °F	
		-40 °C	-30	-20	-10	0	+10	+20	+30	+40	+50 °C	
GREASING OF THE BOOM		MANITOU BLUE MULTI-PURPOSE LUBRICANT										
<b>HYDRAULICS</b>												
DESCRIPTION		CAPACITY	RECOMMENDATION									
			-40 °F	-22	-4	+14	+32	+50	+68	+86	+104	+122 °F
			-40 °C	-30	-20	-10	0	+10	+20	+30	+40	+50 °C
HYDRAULIC FLUID TANK		110.95 US qt (105 L)	ISO VG 100 ISO VG 68 <b>MANITOU ISO VG 46 HYDRAULIC FLUID</b> ISO VG 37 ISO VG 32									
<b>CAB</b>												
DESCRIPTION		CAPACITY	RECOMMENDATION									
WINDSHIELD WASHER TANK		8.45 US qt (8 L)	WINDSHIELD WASHER FLUID									
<b>FRONT AXLE</b>												
DESCRIPTION		CAPACITY	RECOMMENDATION									
FRONT AXLE DIFFERENTIAL		8.45 US qt (8 L)	SPECIAL MANITOU OIL FOR IMMERSER BRAKES									
			-40 °F	-22	-4	+14	+32	+50	+68	+86	+104	+122 °F
			-40 °C	-30	-20	-10	0	+10	+20	+30	+40	+50 °C
FRONT WHEEL REDUCING GEAR		2 x 0.69 US qt (2 x 0.65 L)	MANITOU SAE80W90 MECHANICAL TRANSMISSION OIL									
			-40 °F	-22	-4	+14	+32	+50	+68	+86	+104	+122 °F
			-40 °C	-30	-20	-10	0	+10	+20	+30	+40	+50 °C
FRONT WHEEL REDUCING GEAR PIVOTS			MANITOU BLACK MULTI-PURPOSE LUBRICANT									
			-40 °F	-22	-4	+14	+32	+50	+68	+86	+104	+122 °F
			-40 °C	-30	-20	-10	0	+10	+20	+30	+40	+50 °C
FRONT AXLE OSCILLATION			MANITOU BLUE MULTI-PURPOSE LUBRICANT									
<b>REAR AXLE</b>												
DESCRIPTION		CAPACITY	RECOMMENDATION									
REAR AXLE DIFFERENTIAL		6.34 US qt (6 L)	SPECIAL MANITOU OIL FOR IMMERSER BRAKES									
			-40 °F	-22	-4	+14	+32	+50	+68	+86	+104	+122 °F
			-40 °C	-30	-20	-10	0	+10	+20	+30	+40	+50 °C
REAR WHEEL REDUCING GEAR		2 x 0.69 US qt (2 x 0.65 L)	MANITOU SAE80W90 MECHANICAL TRANSMISSION OIL									
			-40 °F	-22	-4	+14	+32	+50	+68	+86	+104	+122 °F
			-40 °C	-30	-20	-10	0	+10	+20	+30	+40	+50 °C
REAR WHEEL REDUCING GEAR PIVOTS			MANITOU BLACK MULTI-PURPOSE LUBRICANT									
			-40 °F	-22	-4	+14	+32	+50	+68	+86	+104	+122 °F
			-40 °C	-30	-20	-10	0	+10	+20	+30	+40	+50 °C
REAR AXLE OSCILLATION			MANITOU BLUE MULTI-PURPOSE LUBRICANT									

<b>CHASSIS</b>										
DESCRIPTION	RECOMMENDATION									
	-40 °F	-22	-4	+14	+32	+50	+68	+86	+104	+122 °F
	-40 °C	-30	-20	-10	0	+10	+20	+30	+40	+50 °C
FRAME LEVELING										<b>MANITOU BLUE MULTI-PURPOSE LUBRICANT</b>

<b>AUTOMATIC CENTRAL GREASING (OPTION)</b>											
DESCRIPTION	CAPACITY	RECOMMENDATION									
		-40 °F	-22	-4	+14	+32	+50	+68	+86	+104	+122 °F
		-40 °C	-30	-20	-10	0	+10	+20	+30	+40	+50 °C
GREASING UNIT TANK	3.17 US qt (3 L)										<b>MANITOU BLUE MULTI-PURPOSE LUBRICANT</b>

## CONDITIONING

<b>OIL</b>						
PRODUCT	PACKAGING / REFERENCE					
	1.06 US qt	2.11 US qt	5.28 US qt	5.3 US gal	14.5 US gal	55.2 US gal
	1 ℓ	2 ℓ	5 ℓ	20 ℓ	55 ℓ	209 ℓ
- MANITOU EVOLOGY OIL 10W40 API CJ4			895837	895838	895839	895840
- MANITOU DX III G AUTOMATIC TRANSMISSION OIL	958186		947972	947973	947974	947975
- MANITOU ISO VG 46 HYDRAULIC FLUID			545500	582297	546108	546109
- SPECIAL MANITOU OIL FOR IMMersed BRAKES			545976	582391	947918	894257
- MANITOU SAE80W90 MECHANICAL TRANSMISSION OIL		499237	720184	546330	546221	546220

<b>GREASE</b>						
PRODUCT	PACKAGING / REFERENCE					
	0.42 US qt	0.88 lbs	2.20 lbs	11.02 lbs	44.09 lbs	110.23 lbs
	400 Mℓ	400 GR	1 KG	5 KG	20 KG	50 KG
- MANITOU BLACK MULTI-PURPOSE LUBRICANT		947766	161590			499235
- MANITOU BLUE MULTI-PURPOSE LUBRICANT		161589		554974	958177	958176

<b>LIQUID</b>						
PRODUCT	PACKAGING / REFERENCE					
	1.06 US qt	2.11 US qt	5.28 US qt	5.3 US gal	14.5 US gal	55.5 US gal
	1 ℓ	2 ℓ	5 ℓ	20 ℓ	55 ℓ	210 ℓ
- COOLANT -35 °C			894967	894968		894969
- WINDSHIELD WASHER FLUID	490402		486424			
- DEF (diesel exhaust fluid)			958575		958576	

**CHECK**

**Lift truck environment**

Carry out a general inspection around the lift truck:

- Fluid leaks or stains on the ground.
- Additional objects on the lift truck and in the cab.
- Mounting and locking of the attachment.
- Mounting and adjustment of rear-view mirrors.
- Condition of the tires, to detect cuts, blisters, wear, etc.

**⚠ IMPORTANT ⚠**

Follow the operator instructions (➔ 1 - OPERATING AND SAFETY INSTRUCTIONS: OPERATOR INSTRUCTIONS).

**CLEANLINESS OF THE FORKLIFT**

- Cleanliness of lights and rear-view mirror.
- Excess dirt or build-up of material (e.g. straw, flour, sawdust, organic waste, etc.).
- On a daily basis, according to the conditions of use and the environment, the operator should ensure that the forklift truck is kept in a clean condition.
- Particular attention should be paid to accumulations of flammable materials (e.g. straw, flour, sawdust, organic waste, etc.) and fuel or lubricant leaks, as these significantly increase the risk of fire outbreaks.
- A regular inspection of the whole lift truck, especially the engine housing and the central part of the frame, is necessary to see how frequently it needs to be cleaned to prevent these potential accumulations of material or leakages.

**CHECK**

**Engine oil level**

Place the lift truck on level ground with the engine stopped, and let the oil settle in the sump.

- Open the engine hood.
- Pull out dipstick 1.
- Clean the dipstick and check the correct level between the two notches.
- If necessary, add oil (➔ LUBRICANTS AND FUEL) through the filler hole 2.
- Visually check that there is no leakage or seepage.

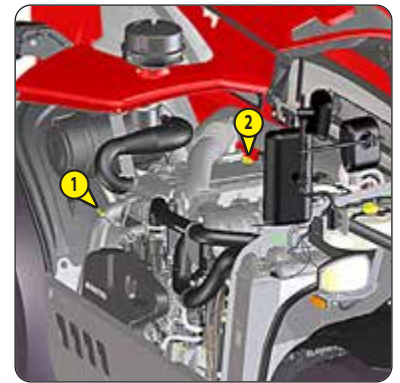

**CHECK**

**Coolant level**

Place the lift truck on level ground with the engine stopped, and allow the engine to cool.

**⚠ IMPORTANT ⚠**

To avoid any risk of spraying or scalding, wait until the engine has cooled down before removing the cooling system filler plug.

In the event of an emergency, it is possible to use water as the coolant, but then proceed to replace the coolant as soon as possible.

- The liquid must be at the MAX. level on the expansion tank 1.
- If necessary, add coolant (➔ LUBRICANTS AND FUEL) through the filler hole 2.
- Visually check that there is no leakage or seepage.

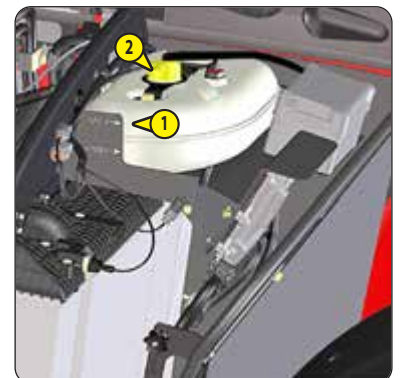

## CHECK

## Fuel pre-filter

### ⚠ IMPORTANT ⚠

*Never smoke or use open flames in the area.  
The diesel engine must be switched off.*

*Consult the maintenance personnel if there is doubt about the condition of the water separator.*

- Check for water in the tank 1 and drain, if necessary.
- Place a receptacle under the drain plug 2 and loosen it in two to three thread turns.
- Allow the diesel fuel to flow out until it is free from impurities and water.
- Tighten the drain plug 2 while the diesel fuel is running out.
- Close the engine hood.



## CHECK

## Greasing unit level (OPTION)

Check the following points of the greasing system:

- The grease level in the greasing unit tank.
- The condition of the greasing unit (damage and leaks).
- No damage or leaks on the primary and secondary lines.
- There must be a collar of fresh grease on all of the greasing points.

The greasing unit is equipped with a filter coupling 1 on which a grease pump can be installed.

- Top up with the recommended grease as required (⇐ LUBRICANTS AND FUEL).

### FILLING PROCEDURE:

- Carefully clean the filter coupling 1 and your filling system.
- Connect your filling system to the filter coupling.
- Fill the tank to its maximum level as indicated on the tank.



### ⚠ IMPORTANT ⚠

*Never fill the tank higher than the maximum level indicated, as this may damage the system.  
If filling is difficult, check the condition of the filter coupling and replace it.*

- Remove your filling system.
- Clean the filter coupling before putting it back.

## ➔ 50H - WEEKLY SERVICE OR EVERY 50 HOURS OF OPERATION

### CHECK

### Gear box oil level

Place the lift truck on level ground with the boom raised and the engine running.

- Bring the gearbox oil up to its operating temperature (50°C - 80°C).

#### **⚠ IMPORTANT ⚠**

**Raise the boom and place the boom safety wedge on the rod of the lifting cylinder (↖ 1 - INSTRUCTIONS AND SAFETY RECOMMENDATIONS: LIFT TRUCK MAINTENANCE INSTRUCTIONS).**

- Unscrew the level plug 1.
- Wipe the dipstick and check the correct level against the MAX mark.
- If necessary, add oil (↖ LUBRICANTS AND FUEL).
- Visually check that there is no leakage or seepage of oil in the gearbox.



### CHECK

### Tire pressure

### CHECK

### Wheel nut torque

#### **⚠ IMPORTANT ⚠**

**Check that the air hose is correctly connected to the tire valve before inflating and keep all persons at a distance during inflation. Inflate to the recommended tire pressures.**

- Check the wheel nut torque. Non-compliance with this instruction can lead to deterioration and breakage of the wheel lugs and distortion of the wheels.
- Check and restore tire pressure, if necessary (↖ DESCRIPTION: TIRES).

NOTE: An OPTIONAL wheel tool kit is available.

### CHECK

### Front axle differential seal

### CHECK

### Rear axle differential seal

Place the lift truck on level ground with the engine stopped.

- Visually check that there is no leakage or seepage.
- If there is any leakage or seepage, check the level:
  - Remove the level plug 1, the oil should be flush with the edge of the hole.
  - If necessary, add oil (↖ LUBRICANTS AND FUEL) through the filler hole 2.
  - Refit and tighten the level plug 1 (tightening torque 25 - 36 ft-lbs 34 - 49 N.m).

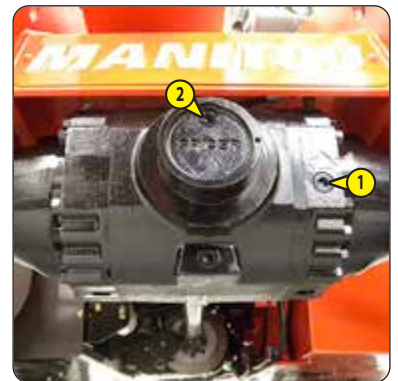

### CHECK

### Front wheel reducer seals

### CHECK

### Rear wheel reducer seals

Place the lift truck on level ground with the engine stopped.

- Visually check that there is no leakage or seepage.
- If there is any leakage or seepage, check the level:
  - Place level plug 1 in a horizontal position.
  - Remove the level plug; the oil should be flush with the edge of the opening.
  - If necessary, add oil (↖ LUBRICANTS AND FUEL) by the same hole.
  - Refit and tighten the level plug (tightening torque 25 - 36 ft-lbs 34 - 49 N.m).



## CHECK

### Boom pad slide pathways

To preserve optimum operation, the pad slide pathways should be correctly lubricated:

#### ⚠ IMPORTANT ⚠

**MANDATORY GREASING OF THE BOOM AFTER:**  
*Cleaning the boom, especially after using high pressure cleaner.  
The forklift has been unused for a long period of time.*

- Fully extend the boom.
- Check the condition of the surface of the pad slide pathways, surface run in (steel whitened) without traces of corrosion.
- If necessary lubricate the pad slide pathways (↔ LUBRICANTS AND FUEL).
- Telescope the boom several times in order to spread the lubricant evenly.
- Remove the surplus lubricant.

#### ⚠ IMPORTANT ⚠

*If the lift truck is used in an abrasive environment (dust, sand, coal) use lubricating varnish (MANITOU Part No.: 483536). Contact your dealer.*



## CHECK

### Hydraulic fluid level

Place the lift truck on level ground with the engine stopped, and the boom retracted and lowered as far as possible.

#### ⚠ IMPORTANT ⚠

*Use a clean funnel and clean the underside of the oil drum before filling.*

- Press the button 1 to open the tank filler access panel 2.
- Visually check that there is no leakage or seepage.
- Check dipstick 3, the correct level must be at the level of the red dot.
- If necessary, add oil (↔ LUBRICANTS AND FUEL).
- Remove the lock 4 of the filler cap 5.
- Add oil through filler port.
- Refit the cap and its lock.
- close the filling access panel 2.

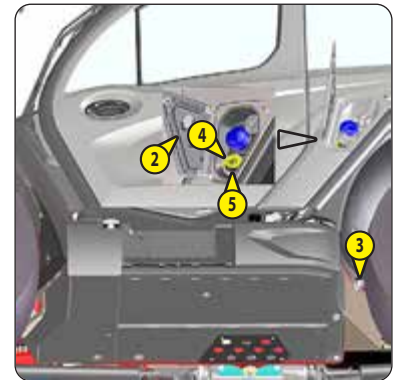

**CHECK**

**Windshield washer fluid level**

- Open the protective casing 1 with the ignition key.
- Visually check the level in tank 2.
- If necessary, add windshield washer fluid (↩ LUBRICANTS AND FUEL).
- Remove the cap 3.
- Add windshield washer liquid through filler port.
- Refit the cap.



**CLEAN**

**Radiator harness**

**⚠ IMPORTANT ⚠**

*In a polluting atmosphere, clean the radiator cores every day. Do not use a water jet or high pressure steam as this could damage the fins.*

- If necessary, clean the suction grid on the engine hood.
- Open the engine hood and the lower cover.
- Using a soft cloth, clean the radiator core 1 in order to remove as much dirt as possible.
- Remove dirt via the panel 2 using handle 3.
- Close the lower cover and the engine hood.

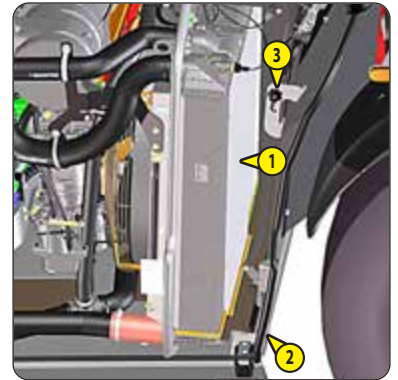

**CLEAN**

**Condenser harness (Air conditioning OPTION)**

**⚠ IMPORTANT ⚠**

*In a polluting atmosphere, clean the radiator harness daily. Do not use a water jet or high-pressure steam as this could damage the condenser fins.*

- Visually check whether the condenser is clean and clean it if necessary.
- Clean the condenser using a compressed air jet aimed in the same direction as the air flow.
- Clean with the fans running for best results.



**CHECK**

**Parking brake efficiency**

- Place the lift truck on a 15% slope.
- Activate the parking brake.
- Check that the lift truck is held on the slope.

To be carried out weekly, if the lift truck has been operated for less than 50 hours during the week.

**⚠ IMPORTANT ⚠**

*In the event of prolonged use in an extremely dusty or oxidizing atmosphere, reduce this interval to every 10 hours of service or every day.*

Clean, then lubricate the following points with grease (← LUBRICANTS AND FUEL) and remove the surplus.

**BOOM**

- 1 - Lubricators of the boom pin (2 lubricators).
- 2 - Lubricators of the carriage pin (1 lubricator).
- 3 - Lubricator of the tilting cylinder head pin (1 lubricator).
- 4 - Lubricator of the tilting cylinder foot pin (1 lubricator).
- 5 - Lubricators of the carriage connecting rod pins (3 lubricators).
- 6 - Lubricator of the lifting cylinder foot pin (1 lubricator).
- 7 - Lubricator of the lifting cylinder head pin (1 lubricator).
- 8 - Lubricator of the compensation cylinder foot axle (1 lubricator).
- 9 - Lubricator of the compensation cylinder head axle (1 lubricator).

**FRONT AND REAR WHEEL REDUCTION GEAR PIVOTS**

- 10 - Lubricators of the wheel reduction gear pivot pins (8 lubricators).

**AXLE OSCILLATION**

- 11 - Rear axle oscillation lubricators (2 lubricators).
- 12 - Front axle oscillation lubricators (2 lubricators) MLT 1041 145 PS+ L Y ST5 S1.

**FRAME LEVELING**

- 13 - Lubricator of the tilting corrector cylinder foot axle (2 lubricators) MLT 1041 145 PS+ L Y ST5 S1.
- 14 - Lubricator of the tilting corrector cylinder head pin (1 lubricator) MLT 1041 145 PS+ L Y ST5 S1.

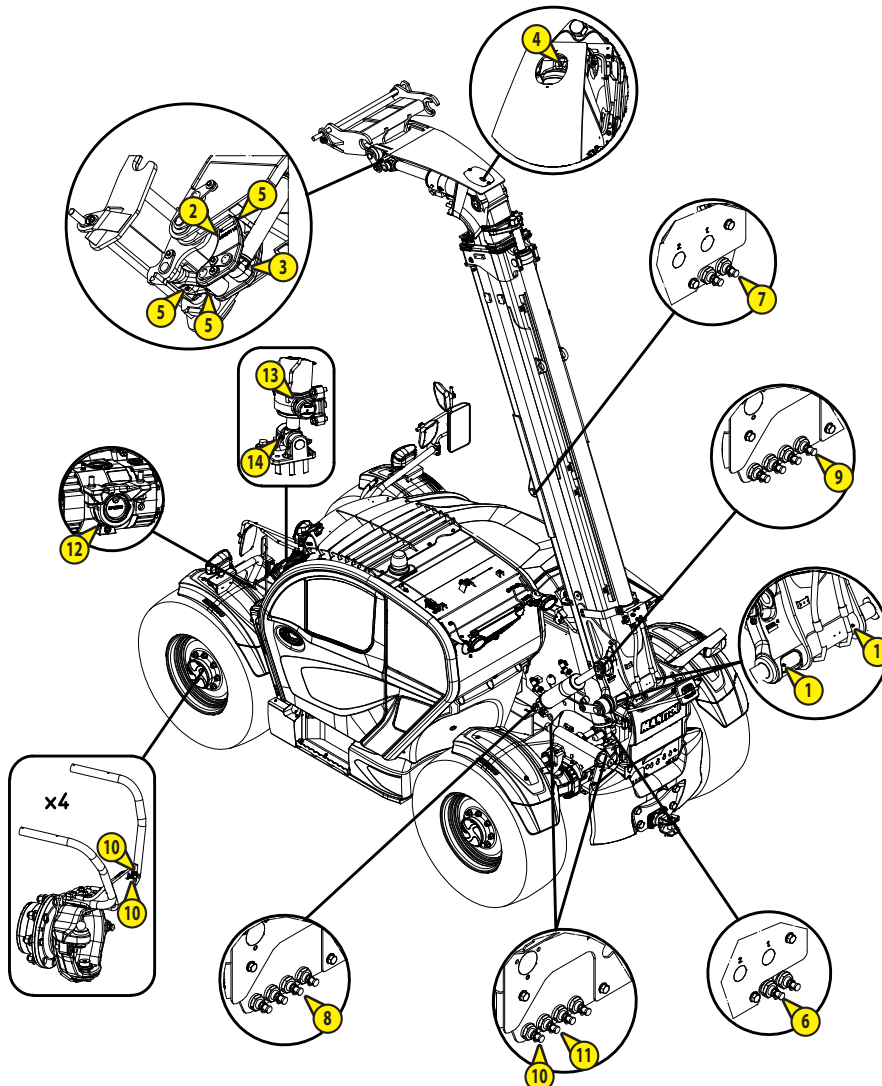

## ➔ 1 500H - PERIODIC MAINTENANCE - EVERY 500 HOURS OF SERVICE OR 1 YEAR

### CHECK

### Hydraulic fluid

MANITOU offers a hydraulic fluid analysis kit which might make it possible to delay the recommended deadline in the periodic maintenance schedule (2,000 hours). In this case we recommend an analysis of the hydraulic fluid every 500 hours or 1 year of service.

The oil analysis kit also makes it possible to confirm the oil quality so as to obtain a deadline of 2,000 hours for specific uses causing constraints on the hydraulic circuit: extreme environmental conditions, use of the attachments with a very high hydraulic flow rate (such as a sweeper, or a concrete mixer).

- Order an oil analysis kit from your dealer.
- Upon receiving the kit, take a sample of oil and follow the instructions shown on the kit.
- According to the results, keep the analysis report or replace the hydraulic fluid.

**Oil analysis kit (MANITOU part no.: 958162).**



### REPLACE

### Front axle differential oil

### REPLACE

### Rear axle differential oil

Place the lift truck on level ground with the engine stopped and the still warm differential oil.

#### **⚠ IMPORTANT ⚠**

*Dispose of the used oil in an ecological manner.*

- Place a container under drain plugs 1 and unscrew them.
- Remove level plug 2 and filling plug 3 to ensure that the oil is drained properly.
- Refit and tighten the drain plugs 1 (tightening torque 25 - 36 ft-lbs 34 - 49 N.m).
- Fill up with oil (⚠ LUBRICANTS AND FUEL) through filler hole 3.
- The level is correct when the oil level is flush with the edge of opening 2.
- Check for any possible leaks at the drain plugs.
- Refit and tighten level plug 2 (tightening torque 25 - 36 ft-lbs 34 - 49 N.m) and filling plug 3 (tightening torque 25 - 36 ft-lbs 34 - 49 N.m).
- Repeat this operation for the rear axle differential.

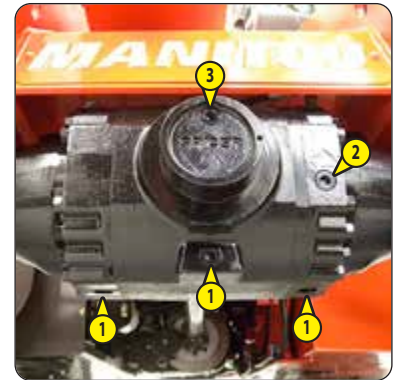

## **REPLACE**

### **Cab ventilation filters**

#### **EXTERNAL CAB VENTILATION FILTER**

- Remove protective casing 1 using the ignition key.
- Remove the cab ventilation filter 2 and replace it with a new one (⇐ FILTER CARTRIDGES AND BELTS).
- Refit the protective casing.



#### **INTERNAL CAB VENTILATION FILTER**

- Remove the protective grid 3.
- Remove the cab ventilation filter 4 and replace it with a new one (⇐ FILTER CARTRIDGES AND BELTS).
- Refit the protective grid.



## **REPLACE**

### **Filter coupling (OPTIONAL Automatic central greasing)**

- Switch off the lift truck's ignition.
- Remove the filter coupling 1 from the greasing unit.
- Clean the hole in the unit with a clean rag.
- Fit the new filter coupling to the unit (⇐ FILTER CARTRIDGES AND BELTS).
- Top up with grease if required.



## **CHECK**

### **Fork wear \***

## **ADJUST**

### **Service brake and parking brake \***

*\* Consult your dealer.*

**CHECK**

**Seat belt**

**⚠ IMPORTANT ⚠**

*Under no circumstances must the lift truck be used if the seat belt is defective (fixing, locking, cuts, tears, etc.).  
Immediately repair or replace the seat belt.*

**SEAT BELT WITH TWO ANCHORING POINTS**

- Check the following points:
  - Fixing of the anchoring points on the seat.
  - Cleanness of the strap and the locking mechanism.
  - Triggering of the locking mechanism.
  - Condition of the strap (cuts, curled edges).

**REELED SEAT BELT WITH TWO ANCHORING POINTS**

- Check the points listed above together with the following points:
  - The correct winding of the belt.
  - Condition of the reel guards.
  - Roller locking mechanism when the strap is given a sharp tug.

NOTE: Replace the seat belt after an accident.

**REPLACE**

**Engine oil**

**REPLACE**

**Engine oil filter**

Place the lift truck on level ground, let the engine run at idle for a few minutes, then stop the engine.

**⚠ IMPORTANT ⚠**

*Tighten the oil filter by hand pressure only and lock the filter in place by a quarter turn.*

**DRAINING THE OIL**

- Open the engine hood and the lower cover.
- Remove access panel 1.

NOTE: When removing access panels and hatches, clean the surrounding environment and remove any accumulations of flammable materials.

- Place a container under the drain hole and unscrew the drain plug 2.
- Take drain hose 3.
- Place the end of the drain hose in the container and screw the hose fully to the drain connector 2.
- Remove the filler plug 4 to ensure correct drainage.

**REPLACEMENT OF THE FILTER**

- Unscrew and discard the engine oil filter 5, together with its seal.
- Clean the filter bracket with a clean, lint-free cloth.
- Lightly grease the seal before refitting the new oil filter (⇐ FILTER CARTRIDGES AND BELTS) on its bracket.

**FILLING WITH OIL**

- Remove, clean and refit drain hose 3.
- Refit and tighten the drain plug 2.
- Fill up with oil (⇐ LUBRICANTS AND FUEL) through filler hole 4.
- Wait a few minutes to allow the oil to flow into the sump.
- Start the engine and let it run for a few minutes.
- Check for possible leaks from the drain plug and the oil filter.
- Stop the engine, wait a few minutes and check the correct level between the two marks on the dipstick 6.
- Top up the level, if necessary.
- Refit access panel 1.

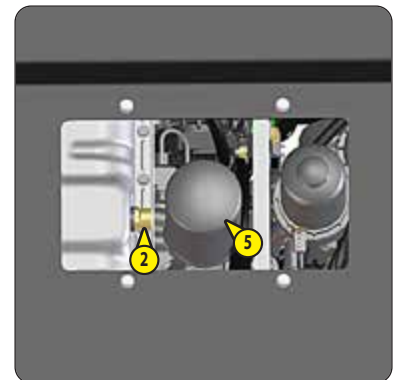
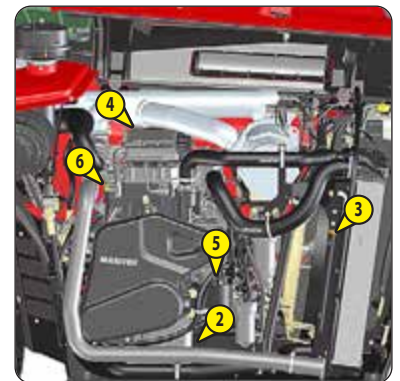
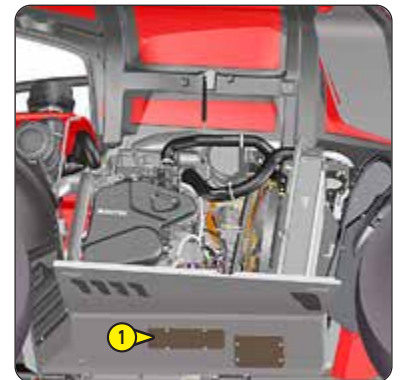

## CLEAN

### REPLACE

## Fuel tank

### Fuel tank breather

Place the lift truck on level ground with the engine stopped.

#### ⚠ IMPORTANT ⚠

*Raise the boom and place the boom safety wedge on the rod of the lifting cylinder (↖ 1 - INSTRUCTIONS AND SAFETY RECOMMENDATIONS: LIFT TRUCK MAINTENANCE INSTRUCTIONS).*

*While carrying out these operations, do not smoke or work near a flame.*

*Never try to carry out a weld or any other operation by yourself, this could provoke an explosion or a fire.*

- Inspect the parts of the fuel circuit and the tank liable to leak, both visually and by touch.
- In the event of a leak, contact your dealer.
- Press the button 1 to open the tank access panel.
- Place a container under drain plug 2 and unscrew the plug.
- Remove the filler plug 3 to ensure correct drainage.
- Rinse with ten liters of clean diesel through filler hole 4.
- Refit and tighten the drain plug 2 (tightening torque 21 - 29 ft-lbs 29 - 39 N.m).
- Unscrew the breather 5 and replace with a new one (↖ FILTER CARTRIDGES AND BELTS) (tightening torque  $3 \pm 1.5$  ft-lbs  $5 \pm 2$  N.m).
- Fill the fuel tank with clean diesel filtered through the filler port.
- Refit the filler plug.
- Close the tank access panel 6.



## REPLACE

## Fuel pre-filter

#### ⚠ IMPORTANT ⚠

*Carefully clean the outside of the pre-filter and its holder, to prevent dust from getting into the system.*

*Tighten the fuel filter by hand only and lock in place by a quarter turn.*

- Switch off the ignition with the ignition key.
- Open the engine hood and the lower cover.
- Place a collecting pan under the tank 1.
- Turn the valve 2 to the OFF position.
- Unscrew the drain valve 3.
- Unscrew the tank 1.
- Clean the tank and the floater with clean fuel.
- Check the condition of the seal 6; replace it, if necessary.
- Unscrew the breather 4 and replace it with a new one (↖ FILTER CARTRIDGES AND BELTS).
- Check the condition of the seal 6; replace it, if necessary.
- Put the floater 5 back in the tank.
- Retighten tank 1 by hand.
- Turn the valve 2 to the ON position.

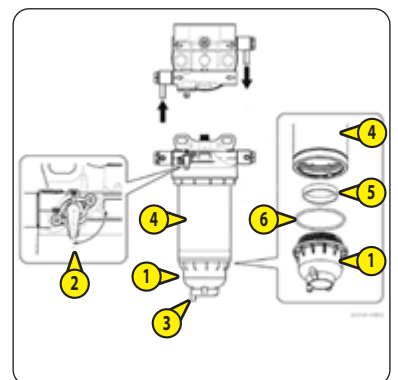
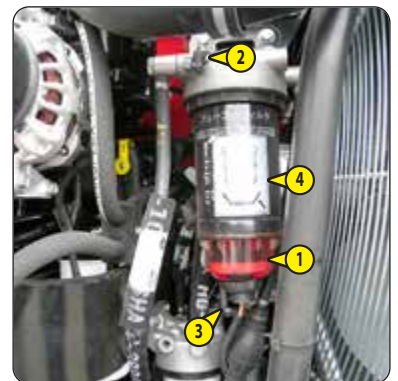

## REPLACE

## Fuel filter

### ⚠ IMPORTANT ⚠

*Carefully clean the outside of the filter and its holder, to prevent dust from getting into the system.*

- Carefully clean the outside of the filter and its holder, to prevent dust from getting into the system.
- Place a receptacle under the filter and empty using drain plug 1.
- Loosen the filter 2 and discard it as well as its seals.
- Clean the inside of the filter head using a brush immersed in clean diesel oil.
- Lightly lubricate the new seals with clean engine oil and refit the assembly with a new filter (↩ FILTER CARTRIDGES AND BELTS).
- Retighten the filter on its support (tightening torque 22 ft-lbs ±4 ft-lbs 30 N.m ±5 N.m).
- Start the engine and check for leaks.

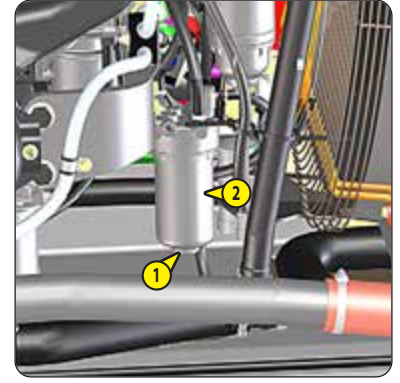

## REPLACE

## Coolant

These operations are to be carried out as necessary or every 2 years at the beginning of winter. Place the lift truck on level ground with the engine stopped and cold.

### ⚠ IMPORTANT ⚠

*The engine does not contain any anti-corrosion elements and must be filled throughout the year with a mixture containing 25% ethylene glycol-based antifreeze.*

### DRAINING THE LIQUID

- Open the engine hood and the lower cover.
- Remove access panel 1.

NOTE: When removing access panels and hatches, clean the surrounding environment and remove any accumulations of flammable materials.

- Place a container under radiator drain plug 2 and unscrew the plug.
- Take drain hose 3.
- Place the end of the drain hose in the container and screw the hose fully to the drain connector 2.
- Remove filler plug 4 from the expansion tank and fully open the heating control to ensure correct drainage.
- Let the cooling circuit drain entirely while ensuring that the ports do not get clogged.
- Check the condition of the hoses as well as the fastening devices and change the hoses if necessary.
- Rinse the circuit with clean water and use a cleaning agent if necessary.

### FILLING WITH COOLANT

- Remove, clean and refit drain hose 3.
- Refit and tighten the radiator drain plug 2.
- Slowly fill the circuit with coolant (↩ LUBRICANTS AND FUEL) up to the middle of the expansion tank 5 by the filler hole.
- Refit the filler plug 4.
- Run the engine at idle for a few minutes.
- Check for any possible leaks.
- Refit access panel 1.
- Check the level and refill if necessary.
- Close the lower cover and the engine hood.

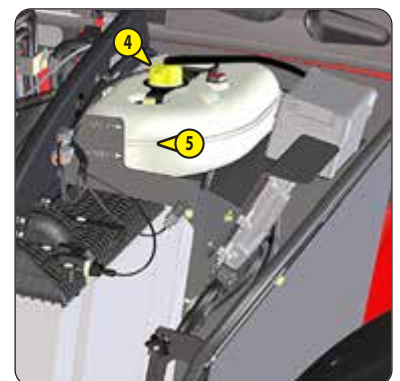
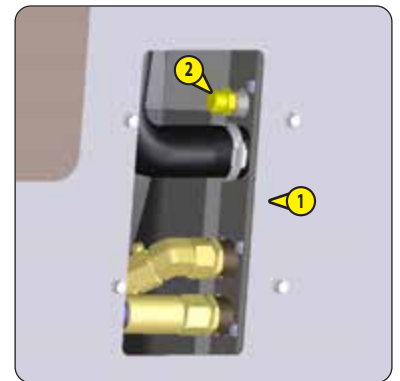
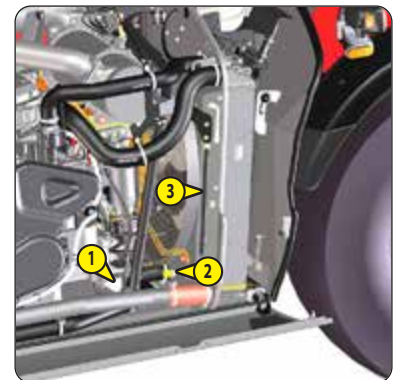

## REPLACE

### Dry air filter cartridge

Prefiltration elements are available for use in very dusty conditions (⇐ FILTER CARTRIDGES AND BELTS). Also, the checking and cleaning periodicity of the cartridge must be reduced (up to 250 hours in a very dusty atmosphere and with pre-filtration).

#### **⚠ IMPORTANT ⚠**

*Change the cartridge in a clean location, with the engine stopped. Never operate the lift truck with a cartridge removed or damaged.*

- Open the engine hood.
- Loosen the locks and remove cover 1.
- Gently remove the cartridge 2 to reduce dust falling as far as possible.
- Leave the safety cartridge in place.
- Carefully clean the following parts with a damp, clean lint-free cloth.
  - The inside of the filter and cover.
  - The inside of the filter inlet hose.
  - The gasket surfaces in the filter and in the cover.
- Check pipes and connections between the air filter and the engine and the connection and state of the clogging indicator on the filter.
- Before fitting check the condition of the new cartridge (⇐ FILTER CARTRIDGES AND BELTS).
- Insert the cartridge in the filter axis and push the cartridge pressing against the outer edge and not in the center.
- Reassemble the cover, guiding the valve downward.



## REPLACE

### "DEF" (Diesel Exhaust Fluid) supply pump filter

Place the lift truck on level ground with the engine stopped.

#### ⚠ IMPORTANT ⚠

*Diesel exhaust fluid is corrosive: protect the bodywork and wear personal protective equipment (gloves and goggles). Carefully clean the outside of the fuel filter, to prevent dust from getting into the system.*

- Switch off the lift truck's ignition and wait for the pump to stop.
- Unscrew the pump cover 1, remove the compensation element 2 and discard.
- Insert the extraction tool 3 (provided with the new filter) into the filter 4 until a click is heard or felt.
- Pull the tool to extract and discard the assembly.
- Lightly oil the cover joint with clean engine oil.
- Replace with a new filter and compensation element (↩ FILTER CARTRIDGES AND BELTS) in the pump and screw the cover 1 (torque 17 ft-lbs 23 N.m).

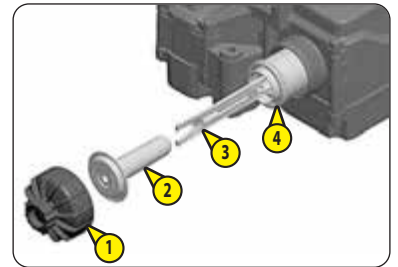

## REPLACE

### Tank breather "DEF" (diesel exhaust fluid)

- Remove access panel 1.
- Unscrew the breather 2 and replace it with a new one (↩ FILTER CARTRIDGES AND BELTS).
- Refit access panel 1.



## REPLACE

## Gearbox oil

## REPLACE

## Gear box oil filter

Place the lift truck on level ground with the engine stopped and the gearbox oil still warm.

### ⚠ IMPORTANT ⚠

*Raise the boom and place the boom safety wedge on the rod of the lifting cylinder (↖ 1 - INSTRUCTIONS AND SAFETY RECOMMENDATIONS: LIFT TRUCK MAINTENANCE INSTRUCTIONS).*

*Dispose of the used oil in an ecological manner.*

*Tighten the oil filter by hand pressure only and lock the filter in place by a quarter turn.*

### DRAINING THE OIL

- Remove cover plate 1.
- NOTE: When removing access panels and hatches, clean the surrounding environment and remove any accumulations of flammable materials.
- Place a container under drain plug 2 and unscrew the plug.
- Remove level plug 2 in order to ensure that the oil is drained properly.

### REPLACEMENT OF THE FILTER

- Unscrew and discard gearbox oil filter 4, together with its seal.
- Clean the filter bracket with a clean, lint-free cloth.
- Lightly grease the seal before refitting the new oil filter (↖ FILTER CARTRIDGES AND BELTS) on its bracket.

### FILLING WITH OIL

- Refit and tighten the drain plug 2 (tightening torque 25 - 40 ft-lbs 34 - 54 N.m).
- Unscrew the filler cap 5, and fill up with oil (↖ LUBRICANTS AND FUEL) through the port, and refit the filler cap 5.
- Bring the gearbox oil up to its operating temperature (50°C - 80°C).
- Check for possible leaks from the drain plug and the oil filter.
- Leave the engine running idle.
- Check the correct level against the MAX mark on the level plug 3.
- Top up the level, if necessary.
- Refit cover plate 1.

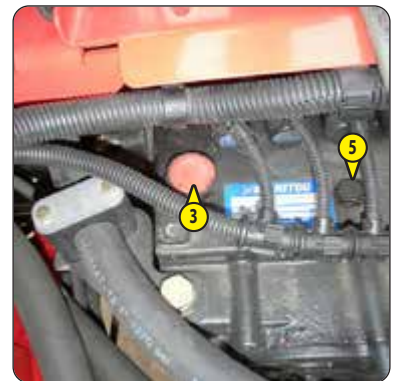

## REPLACE

### Front wheel reducer oil

## REPLACE

### Rear wheel reducer oil

Place the lift truck on level ground with the engine stopped and the reducers' oil still warm.

#### **⚠ IMPORTANT ⚠**

*Dispose of the used oil in an ecological manner.*

- Drain and change the oil of each wheel reduction gear.
- Place drain plug 1 in position A.
- Place a container under the drain plug and unscrew the plug.
- Let the oil drain fully.
- Place the drain port in position B, i.e. in a level port.
- Fill up with oil (↩ LUBRICANTS AND FUEL) through level hole 1.
- The level is correct when the oil level is flush with the edge of the hole.
- Refit and tighten the drain plug (tightening torque 25 - 36 ft-lbs 34 - 49 N.m).

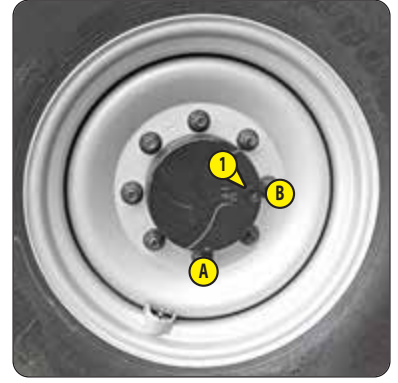

## REPLACE

### Hydraulic return oil filter cartridge

Stop the engine and release the pressure from the systems by operating the hydraulic controls.

#### **⚠ IMPORTANT ⚠**

*Thoroughly clean the outside of the filter and its surroundings before any operation to prevent any risk of polluting the hydraulic system.*

- Remove the protective casing 1.
- Unscrew the fastening screws of the cover 2.
- Wait a few moments while the oil flows into the tank.
- Remove the hydraulic return oil filter cartridge 3 and replace it with a new one (↩ FILTER CARTRIDGES AND BELTS).
- Before replacing the cartridge, clean the inside of the filter body with a clean, lint-free cloth.
- Make sure that the cartridge is correctly positioned and refit the cover 2.
- Refit the protective casing 1.



## REPLACE

### Pressure hydraulic oil filter cartridge

Place the lift truck on horizontal ground with the engine stopped and remove the pressure from the circuits by acting on the hydraulic controls.

#### **⚠ IMPORTANT ⚠**

*Thoroughly clean the outside of the filter and its surroundings before any operation to prevent any risk of polluting the hydraulic system.*

- Unscrew and discard the oil filter 1.
- Clean the filter bracket with a clean, lint-free cloth.
- Lightly grease the seal before refitting the new oil filter (↩ FILTER CARTRIDGES AND BELTS) on its bracket.

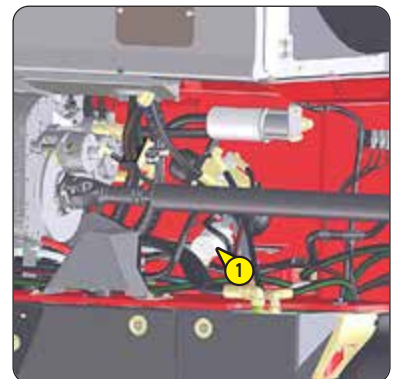

**CHECK** *Engine silent blocks \**

---

**CHECK/ADJUST** *Intake \*\**

---

**CHECK** *Flexible pipes and hoses \*\**

---

**CHECK** *Gearbox silent blocks \**

---

**CHECK** *Brake system pressure \**

---

**CHECK** *Boom pad wear \**

---

**CHECK** *Condition of wiring harnesses and cables \**

---

**CHECK** *Lights and signals \**

---

**CHECK** *Warning indicators \**

---

**CHECK** *Condition of the rear view mirrors \**

---

**CHECK** *Cab structure \**

---

**CHECK** *Chassis structure \**

---

**CHECK** *Attachment mounting system \**

---

**CHECK** *Condition of attachments \**

---

**\*\* Engine service, consult your dealer.**

**\* Consult your dealer.**

## 2000H - PERIODIC MAINTENANCE - EVERY 2,000 HOURS OF SERVICE OR EVERY 4 YEARS

ALSO PERFORM THE 500-HOUR AND 1,000-HOUR PERIODIC MAINTENANCE PROCEDURES.

### CHECK

### Wheel nut tightening torque

- Check the condition of the tires, to detect cuts, blisters, wear, etc.
- Check the tightening torque of the wheel nuts with a torque wrench:
  - Front wheels = 465 ± 70 ft-lbs ( 630 N.m ± 94 N.m)
  - Rear wheels = 465 ± 70 ft-lbs ( 630 N.m ± 94 N.m)

### REPLACE

### Dry air filter safety cartridge

#### ⚠ IMPORTANT ⚠

The safety cartridge replacement frequency is given for information only. It must be changed every second time the dry air filter cartridge is changed.

- For the dismantling and refitting of the cartridge (⏪ 1000H: REPLACE Air filter cartridge).
- Remove the dry air filter safety cartridge 1 carefully, to avoid spilling the dust.
- Clean the gasket surface on the filter with a damp, clean lint-free cloth.
- Check the condition of the new safety cartridge before fitting (⏪ FILTER CARTRIDGES AND BELTS).
- Insert the cartridge in the filter axis and push the cartridge pressing against the outer edge and not the center.



### REPLACE

### Hydraulic fluid

### CLEAN

### Hydraulic fluid tank suction strainers

Place the lift truck on level ground with the engine shut down and the boom retracted and lowered as far as possible.

#### ⚠ IMPORTANT ⚠

Before any intervention, thoroughly clean the area surrounding the drain plug 2, the suction strainer and the outside of the filter on the hydraulic tank.

Use a clean container and funnel and clean the underside of the oil drum before filling.  
Dispose of the used oil in an ecological manner.

### DRAINING THE OIL

- Place a container under drain plugs 1 and unscrew them.
- Open the tank filling access hatch 2 (⏪ BUTTON FOR OPENING TANK FILLING ACCESS PANEL).
- Remove the filler cap lock 3.
- Remove the filler plug 4 to ensure correct drainage.

### CLEANING THE STRAINER

- Remove the protective casing 5.

NOTE: When removing access panels and hatches, clean the surrounding environment and remove any accumulations of flammable materials.

- Disconnect hose 6.
- Remove and clean the suction strainer 7 using a compressed air jet, check its condition and replace if necessary (⏪ 2 - FILTER CARTRIDGES AND BELTS).
- Refit the suction strainer making sure the seal is in the correct position.
- Reconnect the hose 6.

### FILLING WITH OIL

- Refit and tighten the drain plugs 2 (tightening torque 21 - 29 ft-lbs 29 - 39 N.m).
- Fill up with oil (⏪ LUBRICANTS AND FUEL) through filler hole 8.
- Observe the oil level on the dipstick 9; the oil level should be at the level of the red dot.
- Check for any possible leaks at the drain plug.
- Remove the filler plug 4.
- Remove the filler cap lock 3.

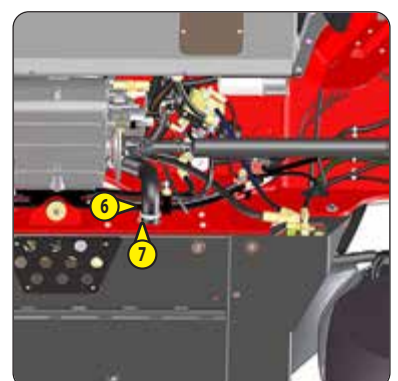
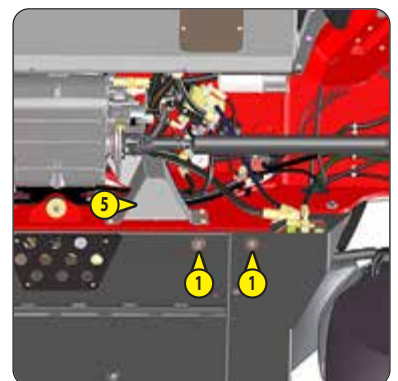
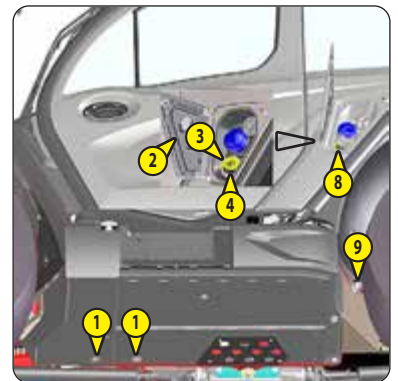

<b>CHECK</b>	<b>Radiator *</b>
<b>CHECK</b>	<b>Transmission pressures *</b>
<b>CHECK</b>	<b>Gearbox calibration *</b>
<b>CHECK</b>	<b>Steering *</b>
<b>CHECK</b>	<b>Steering swivel joints *</b>
<b>CHECK</b>	<b>Condition of boom assembly *</b>
<b>CHECK</b>	<b>Bearings and bushings *</b>
<b>CHECK</b>	<b>Condition of hoses and flexible pipes *</b>
<b>CHECK</b>	<b>Condition of cylinders (leakage, rods) *</b>
<b>CHECK</b>	<b>Hydraulic circuit pressures *</b>
<b>CHECK</b>	<b>Bearings and bushings *</b>
<b>CLEAN</b>	<b>Air conditioning (OPTION) *</b>

**CLEANING CONDENSER AND EVAPORATOR COILS**

**CLEANING CONDENSATE TRAY AND RELIEF VALVE**

**COLLECTING COOLANT TO REPLACE DRIER FILTER**

**REFILLING WITH COOLANT AND CHECKING THE THERMOSTATIC CONTROL AND PRESSURE SWITCHES**

NOTE: When opening the evaporator unit, remember to replace the cover seal.

**⚠ IMPORTANT ⚠**

**NEVER TRY TO REPAIR ANY FAULTS YOURSELF. WHEN REFILLING CIRCUITS, ALWAYS REFER TO A DEALER WHO HAS THE CORRECT SPARE PARTS AND THE TECHNICAL KNOWLEDGE AND TOOLS REQUIRED.**

*In any of the following circumstances, call a doctor.*

*If inhaled, take the victim to fresh air.*

*If there is contact with the skin, wash immediately with plenty of water.*

*If there is frostbite, apply a sterile dressing.*

*If there is contact with the eyes, rinse with clear water for 15 minutes.*

**IMPORTANT INFORMATION REGARDING THE COOLANT USED**

- This product contains fluorinated greenhouse gases covered by the Kyoto Protocol.
- Coolant type: R134A ; it is colorless and odorless and heavier than air. Its GWP (Global Warming Potential) is 1430.
- Do not allow the gases to escape into the atmosphere. Do not open the system under any circumstances, as this could cause refrigerant to escape.
- The compressor has a fluid level gage; never unscrew this gage because it would depressurize the system. The fluid level should only be checked when draining the system.

**\* Consult your dealer.**

## ➔ 4 3000H - PERIODIC MAINTENANCE - EVERY 3,000 HOURS OF SERVICE OR EVERY 6 YEARS

ALSO PERFORM THE 500-HOUR AND 1,000-HOUR PERIODIC MAINTENANCE PROCEDURES.

### REPLACE

### Alternator belt

- Open the engine hood and the lower cover.
- Remove the protective casing 1.
- Place a socket wrench in the square of the automatic tensioner 2 to slacken the belt and remove it.
- Release the force and remove the socket wrench.
- Refit a new alternator belt (⚠ FILTER CARTRIDGES AND BELTS) ensuring that it is properly seated in the grooves of each pulley and tighten the belt using the automatic tensioner 2.

NOTE: Take the opportunity provided by the removal of the belt to check that the pulleys and bearings are working correctly (noise, friction, play, etc.).

- Refit the protective casing 1.
- Close the lower cover and the engine hood.

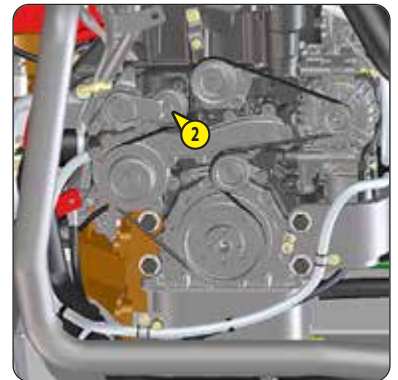

## 🔄 5 4500H - PERIODIC MAINTENANCE - EVERY 4,500 HOURS OF SERVICE OR EVERY 9 YEARS

ALSO CARRY OUT THE PERIODIC MAINTENANCE FOR 500 HOURS OF SERVICE.

### CHECK

### Engine crankcase breather

#### REPLACE

#### Engine breather crankcase filter

- Open the engine hood.
- Remove the crankcase 1.
- Replace the filter 2 with a new one (⇐ FILTER CARTRIDGES AND BELTS).
- Refit the crankcase 1.
- Close the engine hood.

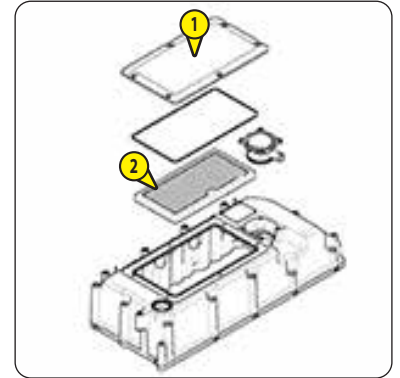

### CHECK

### ECU and associated sensors and actuators \*\*

### CHECK

### Turbocharger \*\*

### CHECK/CLEAN

### (EGR) Exhaust gas recirculation system valve \*\*

### CHECK

### Selective catalytic reduction (SCR) / Diesel oxidation catalyst (DOC) \*\*

### CHECK/CLEAN

### Injector \*\*

\*\* Engine service, consult your dealer.

## 🔄 6 6000H - PERIODIC MAINTENANCE - EVERY 6,000 HOURS OF SERVICE OR 12 YEARS

ALSO PERFORM THE PERIODIC MAINTENANCE AT 500 HOURS, 1,000 HOURS, 2,000 HOURS AND 3,000 HOURS OF SERVICE.

### CHECK

### Diesel Particulate Filter (DPF) \*\*

\*\* Engine service, consult your dealer.

## 🔄 7 9000H - PERIODIC MAINTENANCE - EVERY 9,000 HOURS OF SERVICE OR 18 YEARS

ALSO PERFORM THE PERIODIC MAINTENANCE AT 500 HOURS, 1,000 HOURS, 3,000 HOURS AND 4,500 HOURS OF SERVICE.

### REPLACE

### Diesel Particulate Filter (DPF) \*\*

### REPLACE

### Selective catalytic reduction (SCR) \*\*

\*\* Engine service, consult your dealer.

#### ⚠ IMPORTANT ⚠

Exhaust regeneration is an automated procedure activated by the operator when the following indicator lights are displayed:  or  +  after 50 hours of operation with a 25% engine speed reduction.

- Park the lift truck in a safe and adequately ventilated place.
- Check the following points:
  - forward/reverse selector in neutral,
  - parking brake applied,
  - no action on the hydraulic control joystick,
  - boom in transport position,
  - accelerator pedal released,
  - hand throttle not used (OPTION),
- Check that the fuel level is sufficient.
- Start the lift truck and run the engine for a few minutes to bring it up to its operating temperature (60°C).
- Press and hold the  button for at least two seconds to start the exhaust regeneration procedure.
- The beginning of the procedure is confirmed by a continuously lit indicator lamp.
- Follow the steps described on the information screen.

#### ⚠ IMPORTANT ⚠

The exhaust regeneration procedure must only be stopped if absolutely necessary.

The procedure stops automatically if the operator:

- activates the hydraulic control joystick,
- engages forward or reverse gear,
- switches off the engine,
- presses the  button.

## REPLACE

### Wheels

For this operation, we advise you to use the hydraulic jack (MANITOU part no.: 505507) and the safety support prop (MANITOU part no.: 554772).

#### ⚠ IMPORTANT ⚠

In the event of a wheel being changed on the public highway, make safe the area around the lift truck:

- Stop the lift truck, if possible on firm, level ground.
- Stop the lift truck (< 1 - SAFETY INSTRUCTIONS: DRIVING INSTRUCTIONS UNLADEN AND LADEN).
- Switch on the hazard warning lights.
- Immobilize the lift truck in both directions on the axle opposite to the wheel to be changed.
- Unlock the nuts of the wheel to be changed.
- Place the jack under the flared axle tube, as near as possible to the wheel and adjust the jack.
- Raise the wheel until it is clear of the ground and place the safety support under the axle.
- Completely unscrew the wheel nuts and remove them.
- Free the wheel by reciprocating movements and roll it to the side.
- Slip the new wheel on the wheel hub.
- Hand-tighten the nuts, grease them if necessary.
- Remove the safety support and lower the lift truck with the jack.
- Tighten the lug nuts to the prescribed torque value (< 2000H - PERIODIC MAINTENANCE - EVERY 2,000 HOURS OF SERVICE OR EVERY 4 YEARS) with a torque wrench.



**⚠ IMPORTANT ⚠**

Switch off the ignition with the key, wait 30 seconds, then operate the battery cut-off.  
 Wait 5 minutes before disconnecting the battery, this is required in order to purge the Diesel Exhaust Fluid "DEF" system.

Handling and servicing a battery can be dangerous, take the following precautions:

- Wear protective goggles.
- Keep the battery horizontal.
- Never smoke or work near a naked flame.
- Work in a well-ventilated area.

- In the event of electrolyte being spilled onto the skin or splashed in the eyes, rinse thoroughly with cold water for 15 minutes and call a doctor.

- Remove the protective casing 1.
- Replace the battery 2.



**ADJUST**

**Front headlights**

**RECOMMENDED SETTING**

(according to standard ECE-76/756 76/761 ECE20)

Adjustment of -2 % of the dipped beam harness relative to the horizontal axis of the headlight.

**ADJUSTMENT PROCEDURE**

- Place the unladen lift truck in the transport position and perpendicular to a white wall on flat, level ground.
- Check the tire pressures (<math>\leq 2</math> - DESCRIPTION: TIRES).
- Put the gearshift lever in neutral.

**CALCULATING THE HEIGHT OF THE DIPPED BEAM (H2)**

- h1 = Height of the dipped beam in relation to the ground.
- h2 = Height of the adjusted beam.
- l = Distance between the dipped beam and the white wall.

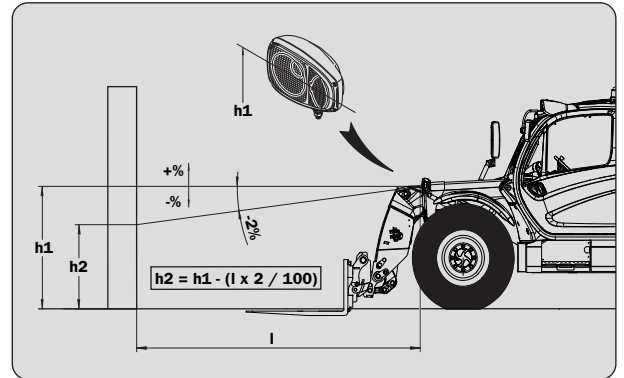

### TOW OR WINCH

### Lift truck

#### ⚠ IMPORTANT ⚠

*Do not tow the lift truck at a speed exceeding 6 km/h. over a maximum distance of 5 km.  
This is a dangerous maneuver.*

*Carefully chock the lift truck before towing, as the parking brake system is inoperative.*

- Place the forward/reverse selection lever and gear lever in neutral.
- Chock the lift truck.
- Remove the cap 1.
- Loosen screw 2 with a pin wrench 3 to release the brake disk. Leave a minimum clearance of 5 mm between the disk 4 and the brake pads 5.
- Put the towing device in place.
- Remove the chocks.
- Switch on the hazard warning lights.

NOTE: Since there will be no power steering or hydraulic brake assistance, operate the steering and controls slowly and with force. Avoid sudden or jerky movements.

#### ⚠ IMPORTANT ⚠

*For adjusting the parking brake, please contact your dealer.*

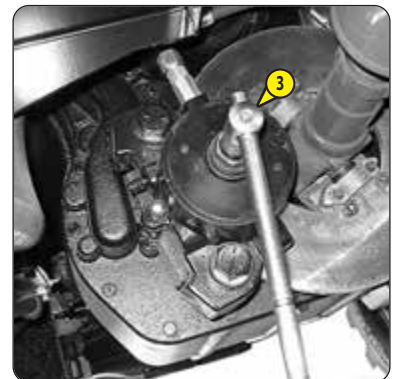
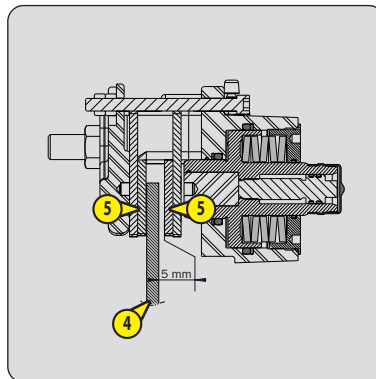
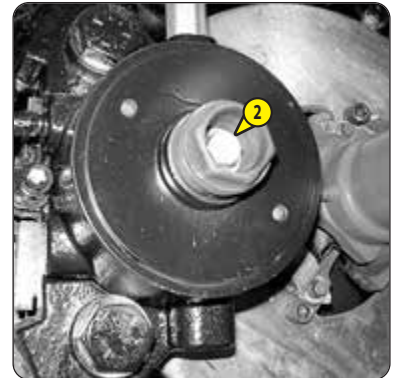
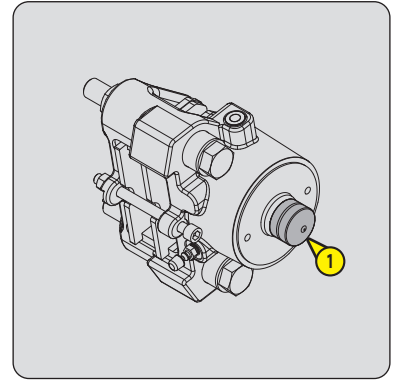

## SLING

## Lift truck

- Take into account the position of the lift truck center of gravity for lifting.

A = 5-4.37 ft-in (1630 mm)      B = 4-1.21 ft-in (1250 mm)

MLT 841 145 PS+

A = 5-3.8 ft-in (1620 mm)      B = 4-1.61 ft-in (1260 mm)

MLT 1041 145 PS+ L

- Place the hooks in the fastening points 1 provided.

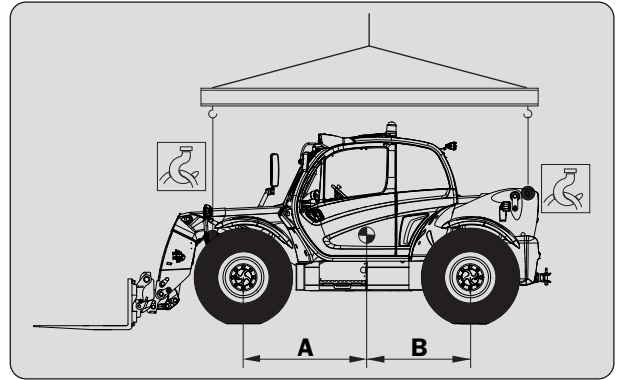

**⚠ IMPORTANT ⚠**

Ensure that the safety instructions associated with the flatbed are complied with before loading the lift truck and that the driver of the carrier vehicle is informed of the dimensions and the weight of the lift truck (<math>\leq 2</math> - DESCRIPTION: SPECIFICATIONS).

Make sure that the flatbed is large enough and has sufficient loading capacity to carry the lift truck. Check also the allowable ground contact pressure of the platform relative to the lift truck.

**⚠ IMPORTANT ⚠**

For lift trucks equipped with a turbo-charged engine, block off the exhaust outlet to avoid rotation of the turbo shaft without lubrication when transporting the vehicle.

**LOADING THE LIFT TRUCK**

- Block the wheels of the platform.
- Attach the loading ramps to the platform in such a way as to give the shallowest possible ramp angle for the lift truck.
- Load the lift truck parallel to the platform.
- Stop the lift truck (<math>\leq 1</math> - OPERATING AND SAFETY INSTRUCTIONS: DRIVING INSTRUCTIONS UNLADEN AND LADEN).

**STOWING THE LIFT TRUCK**

- Fix the chocks to the platform at the front and at the back of each tire.
- Also fix the chocks to the platform on the inside of each tire.
- Secure the lift truck to the platform with sufficiently strong ropes to the anchoring points 1 provided.
- Tighten the ropes.

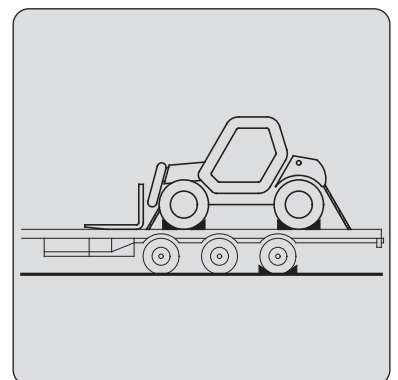
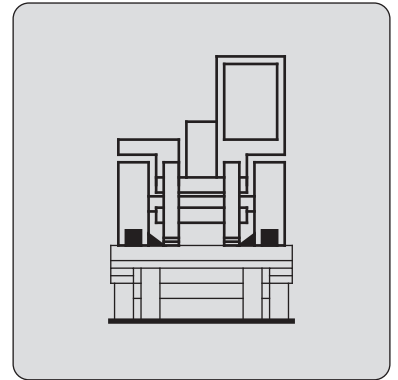
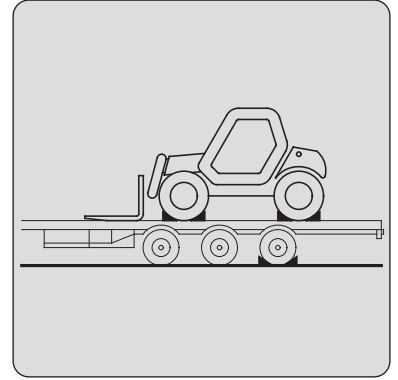

647874-EN-USM3 B102023  
MLT 841 145 PS+ Y ST5 S1  
MLT 1041 145-PS+ -L Y ST5 S1

# ***4 - ATTACHMENTS THAT CAN BE ADAPTED TO THE RANGE***



## 4 - ATTACHMENTS THAT CAN BE ADAPTED TO THE RANGE

<u>INTRODUCTION</u>	4-3
<u>PICKING UP THE ATTACHMENTS</u>	4-4
<u>TECHNICAL SPECIFICATIONS OF ATTACHMENTS</u>	4-6
<u>ATTACHMENT GUARDS</u>	4-13

### INTRODUCTION

- Your lift truck must be used with interchangeable equipment. These items are called: ATTACHMENTS.
- A wide range of attachments is available, guaranteed by MANITOU and designed to fit your lift truck perfectly.

#### **⚠ IMPORTANT ⚠**

*Only attachments approved by MANITOU can be used on its lift trucks (← TECHNICAL CHARACTERISTICS OF ATTACHMENTS).  
The manufacturer cannot be held responsible for any modifications or adaptations to attachments without its knowledge.*

- The attachments are delivered with a load chart concerning your lift truck. The operator's manual and the load chart should be kept in the places provided in the lift truck. For standard attachments, their use is governed by the instructions contained on this notice.

#### **⚠ IMPORTANT ⚠**

*Maximum loads are defined by the capacity of a lift truck taking account of the attachment's weight and center of gravity.  
Should the attachment have a lower capacity than the lift truck, never exceed this limit.*

- Some particular uses require the adaptation of the attachment which is not provided in the price-listed options. Solutions exist, consult your dealer.

#### **⚠ IMPORTANT ⚠**

*Depending on their size, certain attachments may, when the boom is lowered and retracted, come into contact with the front tires and cause damage to them if excavation is activated in the direction of the discharge.*

**TO PREVENT THIS RISK, EXTEND THE TELESCOPE TO A SUFFICIENT EXTENT FOR THE PARTICULAR LIFT TRUCK AND ATTACHMENT SO THAT THIS CONTACT IS NOT POSSIBLE.**

### SUSPENDED LOAD

#### **⚠ IMPORTANT ⚠**

- *Suspended loads MUST be handled with a lift truck designed for that purpose (← 1 - OPERATING AND SAFETY INSTRUCTIONS: INSTRUCTIONS FOR HANDLING LOADS: H - PICKING UP AND PUTTING DOWN A SUSPENDED LOAD).*

## PICKING UP THE ATTACHMENTS

### 1 - ATTACHMENT WITHOUT HYDRAULICS AND HAND LOCKING DEVICE

#### FITTING AN ATTACHMENT

- Ensure that the attachment is in a position facilitating the locking to the carriage. If it is not correctly oriented, take the necessary precautions in order to move it safely.
- Check that the locking pin is in position in the bracket (Fig. A).
- Place the lift truck with the boom lowered in front of and parallel to the attachment, and tilt the carriage forwards (Fig. B).
- Bring the carriage under the locking tube of the attachment, slightly raise the boom, tilt the carriage backwards in order to position the attachment (Fig. C).
- Lift the attachment off the ground to facilitate locking.

#### MANUAL LOCKING

- Take the locking pin on the bracket (Fig. A) and lock the attachment (Fig. D). Do not forget to fit the pin.

#### MANUAL UNLOCKING

- Proceed in the reverse order to MANUAL LOCKING, taking care to refit the locking pin in the bracket (Fig. A).

#### REMOVING THE ATTACHMENT

- Proceed in the reverse order to FITTING AN ATTACHMENT, taking care to store the attachment flat on the ground and in the closed position.

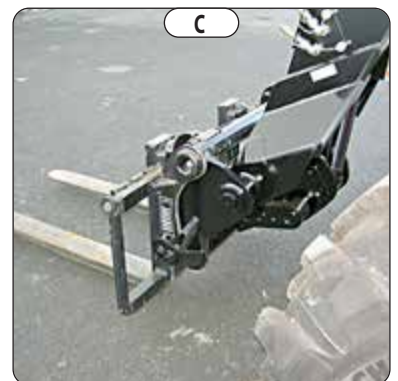
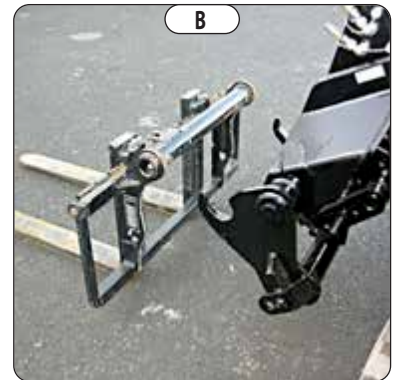
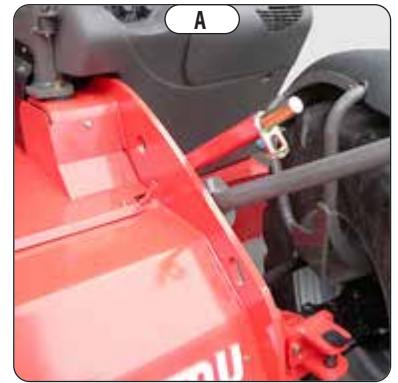

## 2 - HYDRAULIC ATTACHMENT AND MANUAL LOCKING DEVICE

### FITTING AN ATTACHMENT

- Ensure that the attachment is in a position facilitating the locking to the carriage. If it is not correctly oriented, take the necessary precautions in order to move it safely.
- Check that the locking pin is in position in the bracket (Fig. A).
- Place the lift truck with the boom lowered in front of and parallel to the attachment, and tilt the carriage forwards (Fig. B).
- Bring the carriage under the locking tube of the attachment, slightly raise the boom, tilt the carriage backwards in order to position the attachment (Fig. C).
- Lift the attachment off the ground to facilitate locking.

### MANUAL LOCKING AND CONNECTION OF THE ATTACHMENT

#### ⚠ IMPORTANT ⚠

*Make sure that the rapid connectors are clean and protect the holes which are not used, with the caps provided.*

- Take the locking pin on the bracket and lock the attachment (fig. D). Do not forget to fit the pin.
- Stop the engine and keep the ignition on the lift truck.
- Release the pressure in the attachment hydraulic circuit by operating switch 1 on the distributor lever backwards and forwards 4 or 5 times.
- Connect the quick-release couplers according to the logic of the attachment's hydraulic movements (Fig. F).

### MANUAL RELEASE AND DISCONNECTION OF THE ATTACHMENT

- Proceed in the reverse order of paragraph MANUAL LOCKING AND CONNECTING THE ATTACHMENT taking care to refit the locking pin in the bracket (Fig. A).
- **REMOVING THE ATTACHMENT**
- Proceed in the reverse order to FITTING AN ATTACHMENT, taking care to store the attachment flat on the ground and in the closed position.

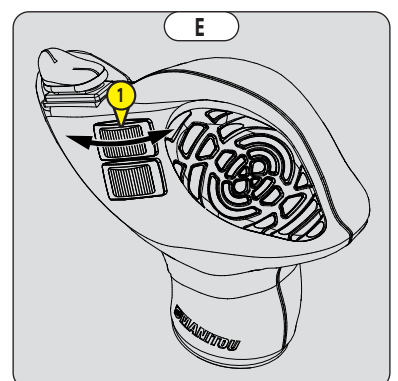
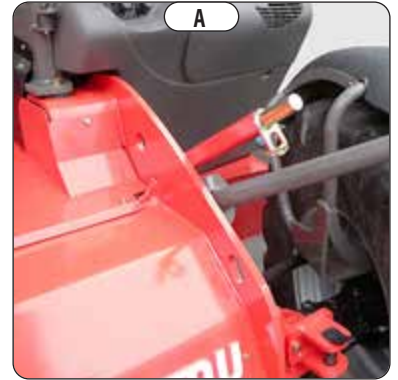

## TECHNICAL SPECIFICATIONS OF ATTACHMENTS

### STANDARDISED TILTING FORK CARRIAGE

	PFB 45 N MT-1260 S2	PFB 45 N MT-1670 S2	PFB 45 N MT-2000 S2
<b>PART No.</b>	<b>654407</b>	<b>653747</b>	<b>653748</b>
Rated capacity	4500 kg	4500 kg	4500 kg
Width	1260 mm	1670 mm	2000 mm
Weight	200 kg	255 kg	300 kg

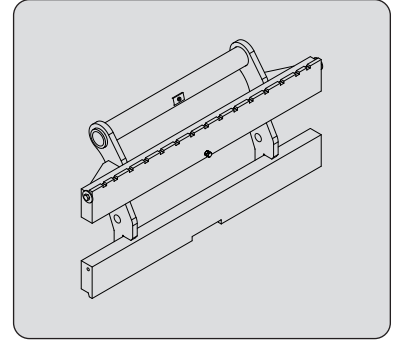

### STANDARDISED FORK

	<b>PART No.</b>	<b>415652</b>
Section		125x50x1200 mm
Weight		78 kg

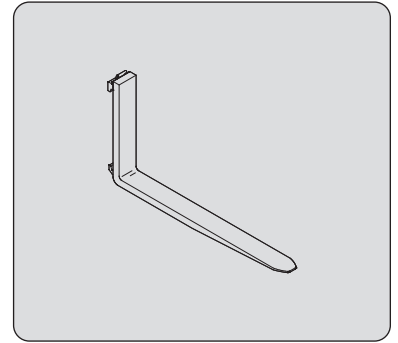

### LOAD BACK REST

	<b>PART No.</b>	<b>727035</b>	<b>572788</b>	<b>572790</b>
Width		1260 mm	1670 mm	2000 mm
Weight		46 kg	56 kg	63 kg

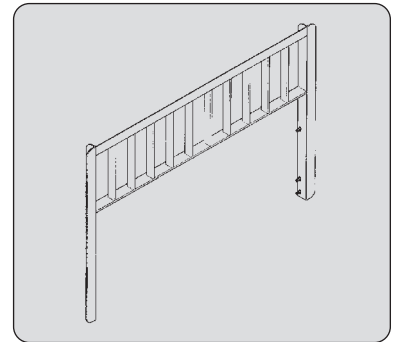

### FLOATING FORK CARRIAGE

	<b>TFF 45 MT-1040</b>	<b>TFF 45 MT-1300</b>
<b>PART No.</b>	<b>653344</b>	<b>653345</b>
Rated capacity	4500 kg	4500 kg
Width	1040 mm	1300 mm
Weight	370 kg	400 kg

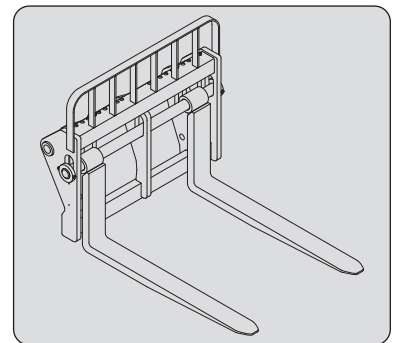

### FLOATING FORK

	<b>PART No.</b>	<b>211922</b>
Section		125x50x1200 mm
Weight		71 kg

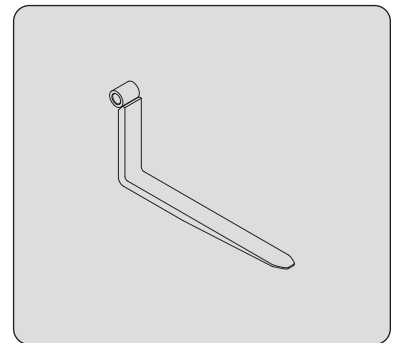

## BUILDING BUCKET

	<b>CBC 900 L2450 S3</b>
<b>PART No.</b>	<b>654470</b>
Rated capacity	982 ℓ
Width	2450 mm
Weight	410 kg

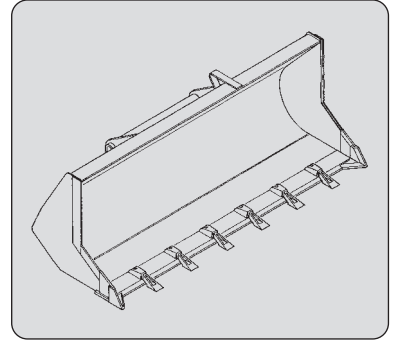

## LOADING BUCKET

	<b>CBR 1000 L2450 S2</b>
<b>PART No.</b>	<b>654716</b>
Rated capacity	1089 ℓ
Width	2450 mm
Weight	410 kg

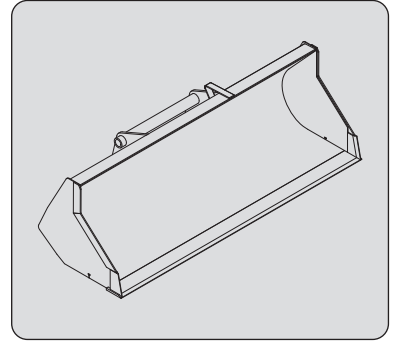

## GRAIN BUCKET

	<b>CBA 3000 L2500 S3</b>
<b>PART No.</b>	<b>570555</b>
Rated capacity	3023 ℓ
Width	2500 mm
Weight	760 kg

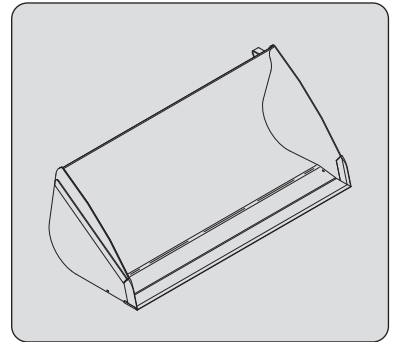

## FARMING BUCKET (REMOVABLE AND REVERSIBLE BLADE)

	<b>CBA 3000 L2500 LDR S3</b>
<b>PART No.</b>	<b>500701</b>
Rated capacity	3023 ℓ
Width	2500 mm
Weight	833 kg

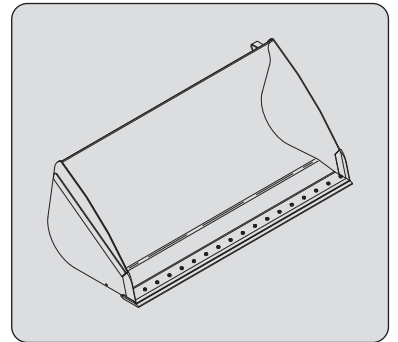

## ENVIRONMENT BUCKET

	<b>CBA 2450/2200 EN</b>
<b>PART No.</b>	<b>52000524</b>
Rated capacity	2224 ℓ
Width	2450 mm
Weight	911 kg

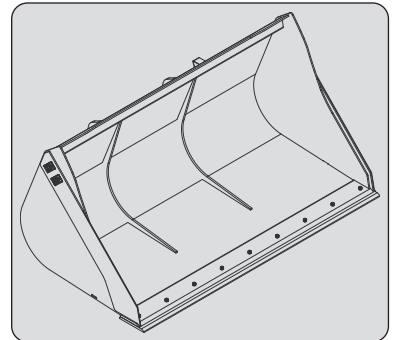

## BUCKET 4-in-1

	<b>PART No.</b>	<b>CB4X1-900 L2450</b>
		<b>751465</b>
Rated capacity		900 ℓ
Width		2450 mm
Weight		765 kg

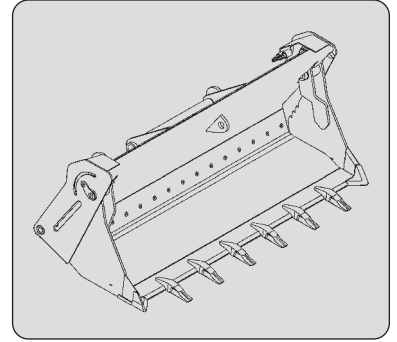

## BEEF BUCKET

	<b>PART No.</b>	<b>BSB 2450/2500</b>
		<b>757953</b>
Rated capacity		2,5 m <sup>3</sup> /1390 kg
Width		2450 mm
Weight		520 kg

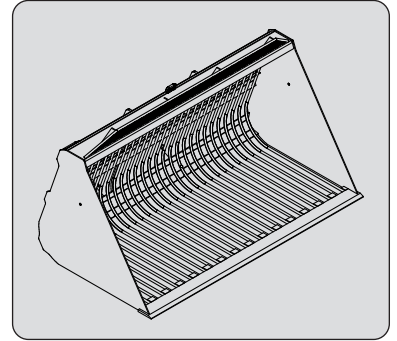

## BALE CLAMP

	<b>PART No.</b>	<b>CLBS 2X7-2100</b>
		<b>52000015</b>
Rated capacity		2100 kg
Width		1800 mm
Teeth		2x7
Weight		780 kg

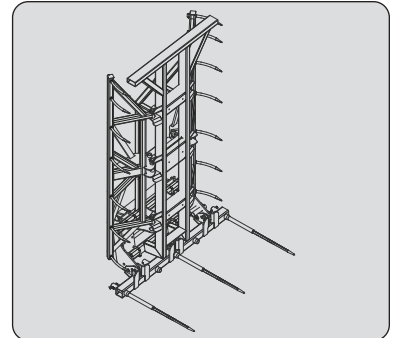

## BALE FORK

	<b>PART No.</b>	<b>FB 1900/1700</b>
		<b>790699</b>
Rated capacity		1700 kg
Width		1878 mm
Teeth		4
Weight		215 kg

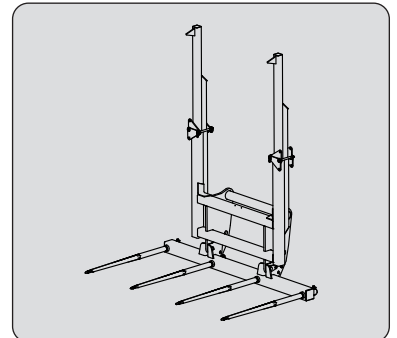

## BOOM CRANE WITH BIG BAG

	<b>PART No.</b>	<b>HBB 1500/2400</b>
		<b>931627</b>
Rated capacity		2400 kg
Weight		186 kg

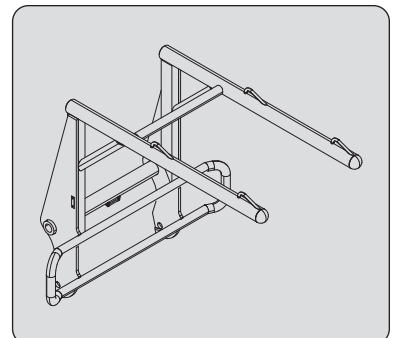

## BALE CLAMP

<b>PART No.</b>	<b>PBG 2X2</b> <b>757639</b>
Rated capacity	800 kg
Width	1090 mm
Teeth	2x2
Weight	158 kg

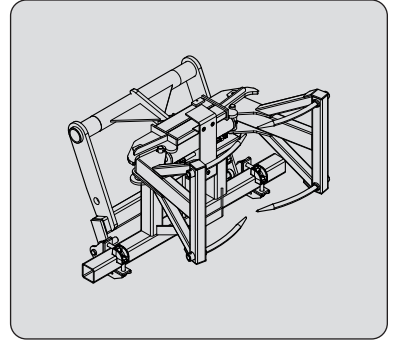

## BALE CLAMP

<b>PART No.</b>	<b>PBG 2X4</b> <b>757612</b>
Rated capacity	1000 kg
Width	1300 mm
Teeth	2x4
Weight	262 kg

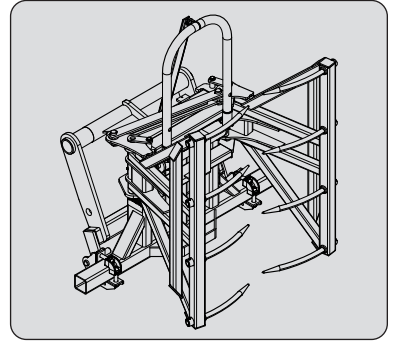

## BALE CLAMP

<b>PART No.</b>	<b>P2BG 2X4</b> <b>790518</b>
Rated capacity	1500 kg
Width	1090 mm
Teeth	2x4
Weight	275 kg

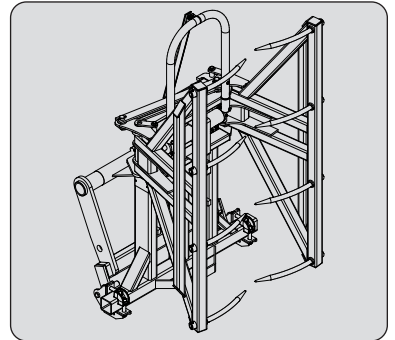

## BALE CLAMP

<b>PART No.</b>	<b>MBC 2X3</b> <b>790506</b>
Rated capacity	800 kg
Width	1196 mm
Weight	290 kg

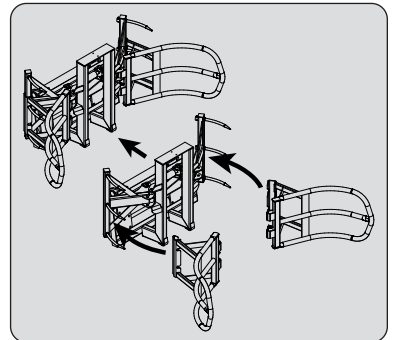

## BALE CLAMP

<b>PART No.</b>	<b>PBE</b> <b>757613</b>
Rated capacity	1000 kg
Width	1600 mm
Weight	242 kg

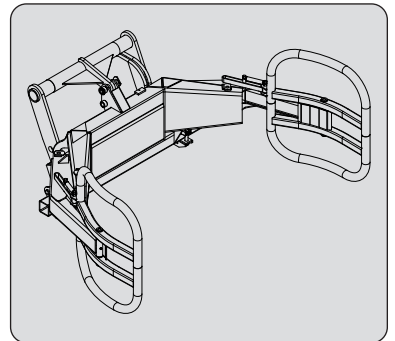

## BUCKET WITH GRAB

	<b>PART No.</b>	<b>CBG 2450 MS</b>
		<b>790308</b>
Rated capacity		1130 ℓ
Width		2450 mm
Teeth		8
Weight		

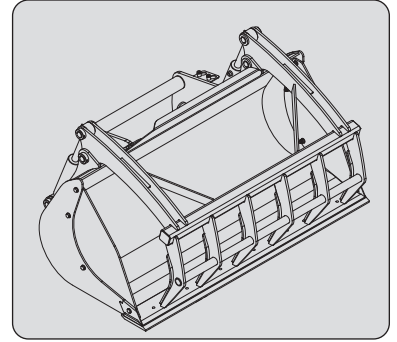

## BUCKET WITH GRAB

	<b>PART No.</b>	<b>CBG 2480/2000 MS</b>
		<b>790656</b>
Rated capacity		2000 ℓ
Width		2480 mm
Teeth		6
Weight		1225 kg

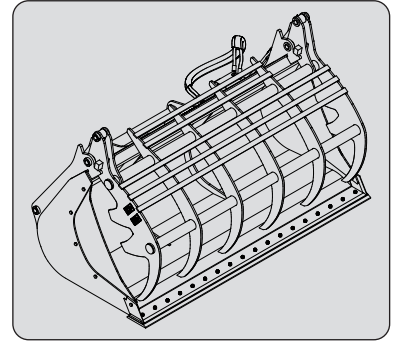

## BUCKET WITH GRAB

	<b>PART No.</b>	<b>CBG 2450 FO</b>
		<b>790309</b>
Rated capacity		1130 ℓ
Width		2450 mm
Teeth		10
Weight		780 kg

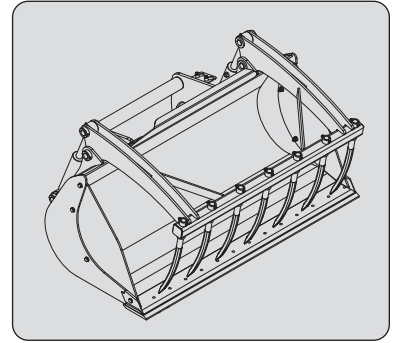

## MANURE FORK WITH GRAB

	<b>PART No.</b>	<b>FFGR 30 MT 2100 S5</b>	<b>FFGR 30 MT 2400 S5</b>
		<b>751403</b>	<b>751405</b>
Rated capacity		1700 Kg	1700 Kg
Width		2100 mm	2400 mm
Finger		10	12
Teeth		7	8
Weight		567 kg	606 kg

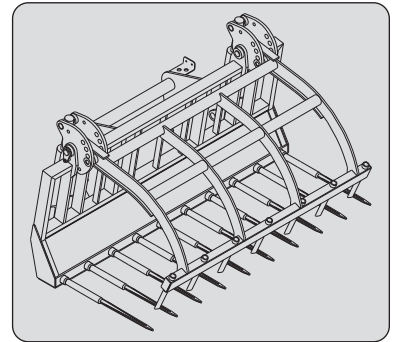

## MANURE FORK

	<b>PART No.</b>	<b>FMG 2450/2000</b>
		<b>790534</b>
Rated capacity		2000 kg
Width		2435 MM
Finger		12
Teeth		5
Weight		686

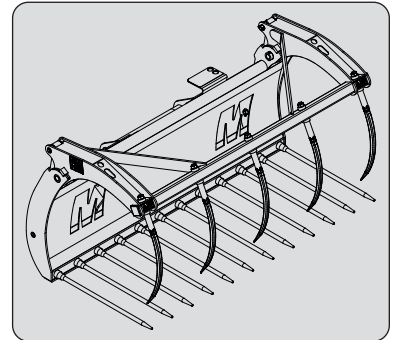

## SPREADER GRAB SHELL

	<b>CGD 2500/2500 FO</b>
<b>PART No.</b>	<b>790312</b>
Rated capacity	2500 ℓ
Width	2505 mm
Teeth	11
Weight	1240 kg

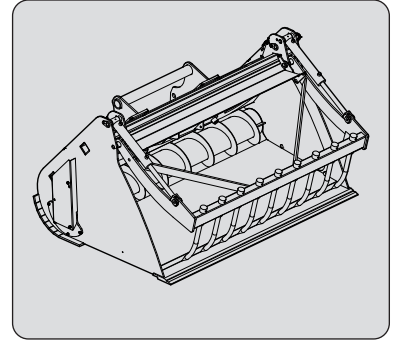

## SINGLE ROTOR SHELL

	<b>CRS 2500/2120</b>
<b>PART No.</b>	<b>790334</b>
Rated capacity	2120 ℓ
Width	2830 mm
Weight	1010 Kg

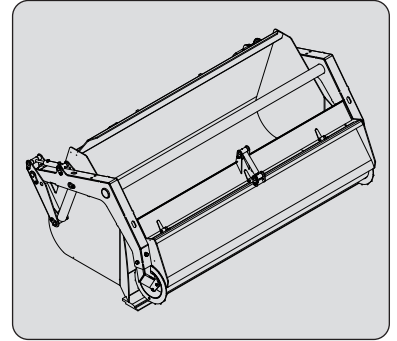

## SHEAR GRAB

	<b>SHG 2400/1800</b>
<b>PART No.</b>	<b>52000383</b>
Rated capacity	1754 ℓ
Width	2400 mm
Weight	936 kg



## SHEAR GRAB BUCKET

	<b>SHB 2400/1800</b>
<b>PART No.</b>	<b>52000387</b>
Rated capacity	1754 ℓ
Width	2400 mm
Weight	1080 kg



## HIGH PRESSURE SCRUBBER

	<b>AHP 40</b>
<b>PART No.</b>	<b>790335</b>
Rated capacity	600 ℓ
Width	1450 mm
Weight	240 kg
Pressure	190 bar

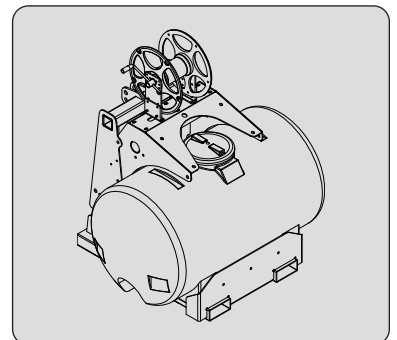

## SWEeper COLLECTOR WITH BRUSH

<b>PART No.</b>	<b>BRB 2200</b>
Rated capacity	790315
Width	530 ℓ
Weight	2600 mm
	925 kg

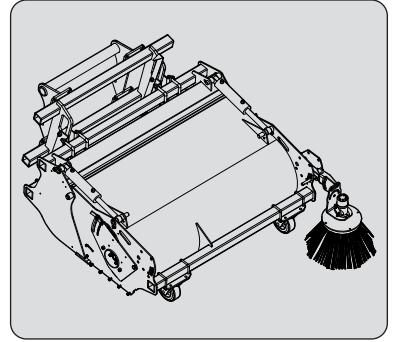

## SWEeper WITH BRUSH

<b>PART No.</b>	<b>SCC 2600</b>
Rated capacity	52000515
Width	2600 mm
Weight	2820 mm
	725 kg

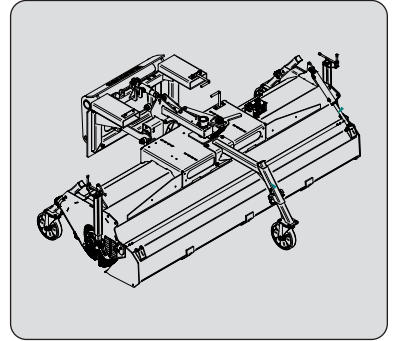

## SWEeper WITH BRUSH

<b>PART No.</b>	<b>SCC 2600+</b>
Rated capacity	52000517
Width	2600 mm
Weight	2820 mm
	780 kg

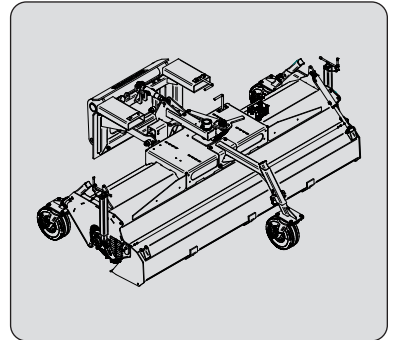

## SWEeper WITH BRUSH

<b>PART No.</b>	<b>SCC 2600 HWA+</b>
Rated capacity	52000519
Width	2600 mm
Weight	2820 mm
	795 kg

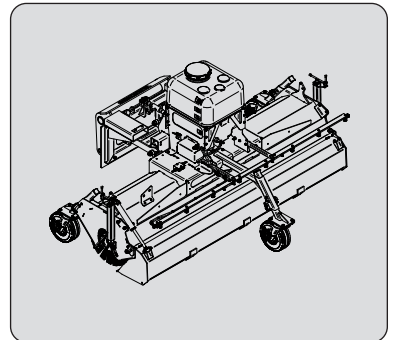

## JCB INTERFACE

<b>PART No.</b>	<b>IC JCB</b>
Rated capacity	52000231
Width	4100Kg
Weight	1296 mm
	155 kg

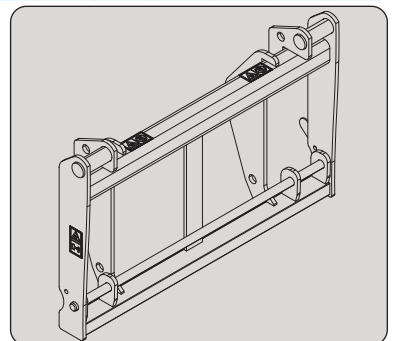

## ATTACHMENT GUARDS

### FORK GUARD

PART No. 227801

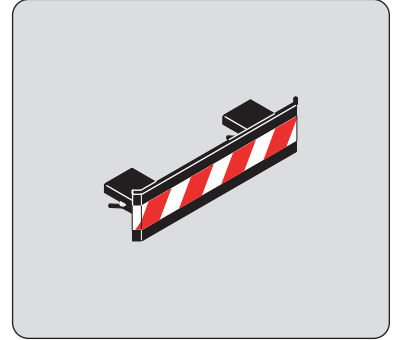

### FORK BLOCK FOR FLOATING FORK CARRIAGE

PART No. 261210

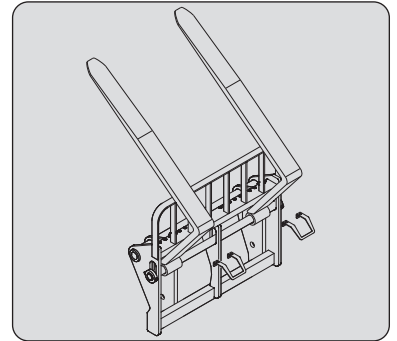

### BUCKET PROTECTOR

*Always ensure that the width of the protector you choose is less than or equal to the width of the bucket.*

Width	PART No. 206734	206732	206730
	1375 mm	1500 mm	1650 mm
Width	PART No. 235854	206728	206726
	1850 mm	1950 mm	2000 mm
Width	PART No. 223771	223773	206724
	2050 mm	2100 mm	2150 mm
Width	PART No. 206099	206722	223775
	2250 mm	2450 mm	2500 mm

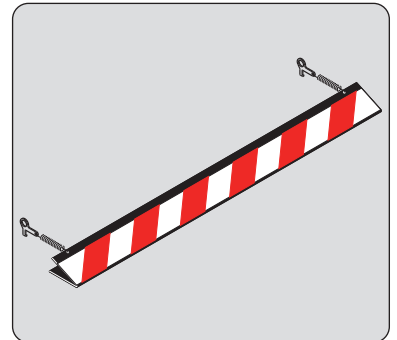

### MANURE FORK GUARD

PART No. 230689

