



THIS ALL-TERRAIN MOBILE AERIAL WORK PLATFORM IS DESIGNED TO OPERATE ON NATURAL OR UNDEVELOPED LAND, OR CONSTRUCTION SITES.

⚠ IMPORTANT ⚠

This document is a short recap on how to operate a mobile aerial work platform and should in no way be substituted for the manual required by Directive 2006/42/EC, which should be read and understood by the operator beforehand and stored in the platform.

All the instructions, including safety instructions, which are in the manual but are not included in this document should be implemented and enforced. The operator must have received proper training and must comply with the applicable road traffic rules.

TECHNICAL SPECIFICATIONS - STANDARD WHEELS AND STANDARD PLATFORM

MACHINE WEIGHT	
- Unladen	6,160 kg (13,580 lbs)
- Under nominal load	6,390 kg (14,087 lbs)
PLATFORM LOAD CAPACITY	
- 2 people	230 kg (507 lbs)
MACHINE SPEED	
- Working speed	1.0 km/h
- Tortoise speed	2.5 km/h
- Ramp speed	2.5 km/h
- Hare speed	5.0 km/h

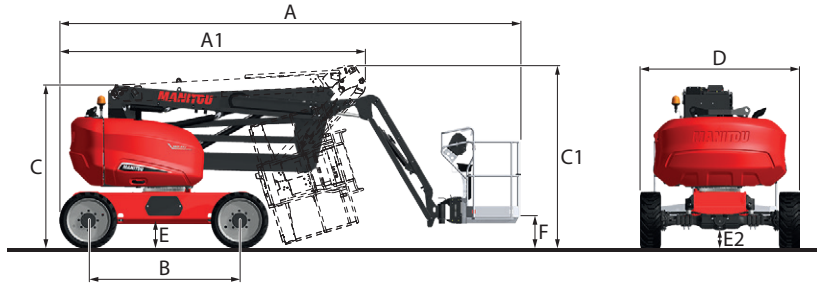

DIMENSIONS	
- A	6,680 mm
- A1	4,445 mm
- B	2,200 mm
- C	2,370 mm
- C1	2,630 mm
- D	2,320 mm
- E	360 mm
- E2	260 mm
- F	450 mm

GROUND LEVEL CONTROL PANEL

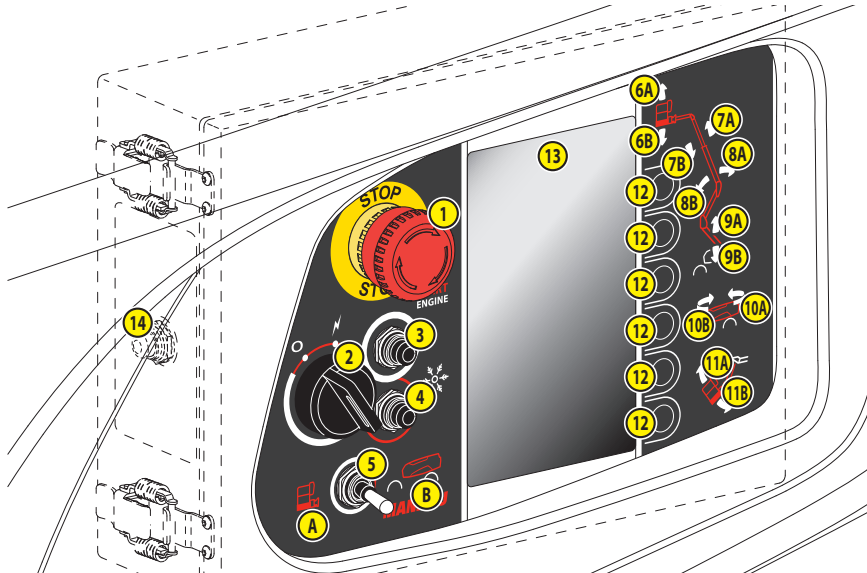

- 1 - EMERGENCY STOP BUTTON
- 2 - IGNITION SWITCH
- 3 - START BUTTON
- 4 - START MODE BUTTON
- 5 - ACTIVATION SWITCH
- A - CONTROLS IN THE PLATFORM
- B - GROUND CONTROLS
- 6 to 11 - CONTROL KEYS
- 6A - RAISE THE JIB ARM
- 6B - LOWER THE JIB ARM
- 7A - EXTEND THE TELESCOPIC ARM
- 7B - RETRACT THE TELESCOPIC ARM
- 8A - RAISE THE MAIN ARM
- 8B - LOWER THE MAIN ARM
- 9A - RAISE THE SECONDARY ARM
- 9B - LOWER THE SECONDARY ARM
- 10A - TURN THE TURNTABLE TO THE RIGHT
- 10B - TURN THE TURNTABLE TO THE LEFT
- 11A - TILT PLATFORM/JIB ARM UP
- 11B - TILT PLATFORM/JIB ARM DOWN
- 12 - NAVIGATION KEYS
- 13 - GROUND LEVEL DISPLAY SCREEN
- 14 - BACKUP PUMP BUTTON

PLATFORM CONTROL PANEL

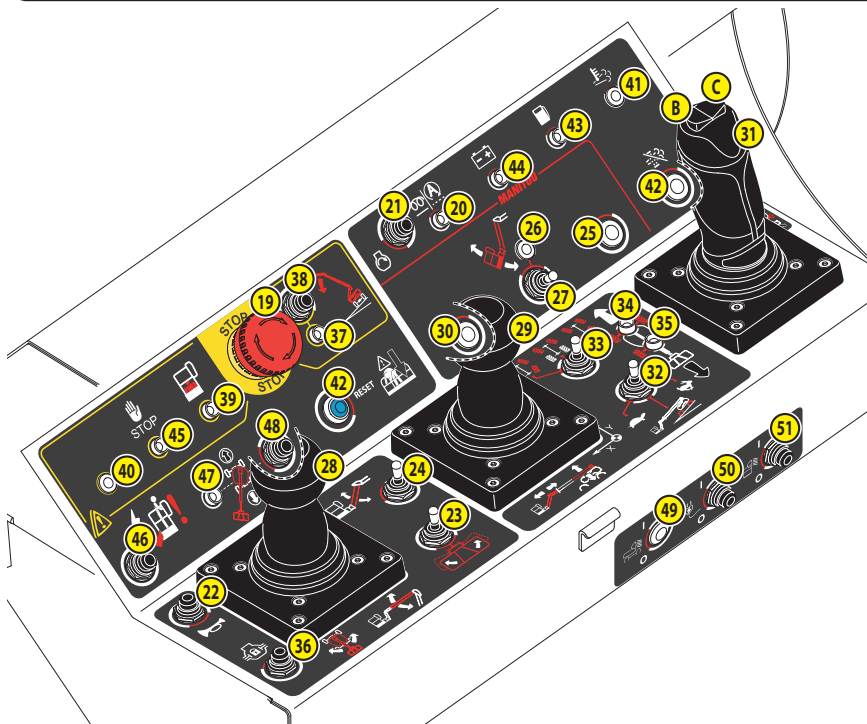

- 19 - EMERGENCY STOP BUTTON
- 20 - PREHEAT INDICATOR LIGHT
- 21 - START BUTTON
- 22 - HORN BUTTON
- 23 - PLATFORM ROTATION SWITCH
- 24 - JIB ARM SWITCH
- 25 - NOT USED
- 26 - NOT USED
- 27 - PLATFORM/JIB ARM TILT SWITCH
- 28 - MAIN ARM/TURNTABLE ROTATION CONTROL HANDLE
- 29 - SECONDARY ARM/TELESCOPIC ARM CONTROL HANDLE
- 30 - NOT USED
- 31 - DRIVING/STEERING CONTROL HANDLE
- B - STEER TO THE LEFT
- C - STEER TO THE RIGHT
- 32 - DRIVING SPEED SWITCH
- 33 - STEERING MODE SWITCH
- 34 - FRONT WHEEL ALIGNMENT INDICATOR LIGHT
- 35 - REAR WHEEL ALIGNMENT INDICATOR LIGHT
- 36 - DIFFERENTIAL LOCK BUTTON
- 37 - OSCILLATION TILT/LOCK INDICATOR LIGHT
- 38 - "USE ON SLOPE" BUTTON
- 39 - OVERLOAD INDICATOR LIGHT
- 40 - NOT USED
- 41 - NOT USED
- 42 - NOT USED
- 43 - FUEL INDICATOR LIGHT
- 44 - BATTERY INDICATOR LIGHT
- 45 - FAULT INDICATOR LIGHT
- 46 - BACKUP PUMP BUTTON
- 47 - TURNTABLE ORIENTATION INDICATOR LIGHT (OPTION)
- 48 - TURNTABLE SLEWING BUTTON (OPTION)
- 49 - NOT USED
- 50 - ELECTRIC GENERATOR BUTTON (OPTION)
- 51 - WORKLIGHT BUTTON (OPTION)
- 52 - RESET BUTTON SPS (OPTION)

⚠ IMPORTANT ⚠

Operators should be aware of the risks connected with using the machine, notably:

- Risk of losing control.
- Risk of losing stability.

When using the machine, a safety helmet must be worn and it is strongly recommended to wear a safety harness.

MACHINE WORKING AREA

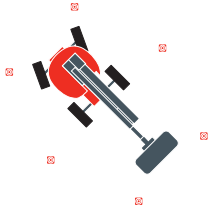

⚠ IMPORTANT ⚠

Do not use the machine if there is a wind speed of over 45 km/h.

- Before using the machine:
- Check the condition of the ground and the bearing surfaces.
 - Mark out the machine's working area.

TILT AND OVERLOAD

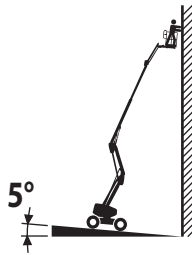

MAXIMUM AUTHORIZED CHASSIS TILT: 5°

If the tilt of the chassis is greater than the maximum authorized value:

- The oscillation tilt/lock indicator light flashes.
- The audible alarm sounds intermittently.

PLATFORM OVERLOAD:

When the platform load has reached maximum load capacity:

- The overload light indicator flashes.
- The audible warning sounds continuously.

ELECTRICAL HAZARD

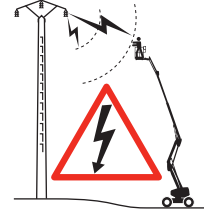

⚠ IMPORTANT ⚠

Never stand or work in the vicinity of any electrical sources.

TURNTABLE LOCKING

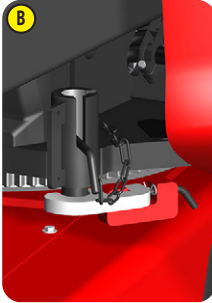
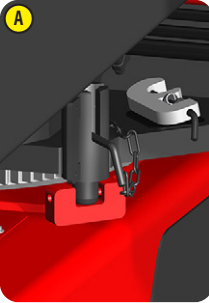

⚠ IMPORTANT ⚠

- (A): the turntable must be locked before loading the machine onto the vehicle and before unloading it.
 - (A): the turntable must be locked during transportation of the machine.
 - (B): the turntable must be locked at 12° before lifting the machine.
- Unlock the turntable before using the machine.

STEERING MODE

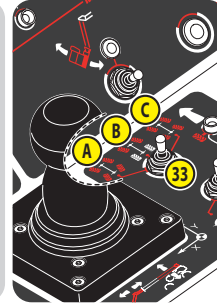

⚠ IMPORTANT ⚠

Always brake the machine before changing the steering mode.

- (A) 4 wheel steer: front and rear steering wheels in opposite directions.
- (B) 2 wheel steer: front steering wheels.
- (C) crab: front and rear steering wheels in the same direction.

EMERGENCY CONTROLS

⚠ IMPORTANT ⚠

Pay attention to any constructions or objects that may be under the platform.

If the operator in the platform should fall ill or find himself incapable of maneuvering, somebody on the ground can take over the machine controls using the ground level control panel.

If the machine is operational:

- Push and hold the activation switch (5) to the right, ground level controls position (B).
- Use the appropriate control buttons to position the platform.
- Release the activation switch.

If the machine has broken down:

- Open the right-hand turntable cover.
- Press the backup pump button (14).
- Position the platform by activating the machine's functions described on the "emergency controls procedure" stickers.
- Release the backup pump button.

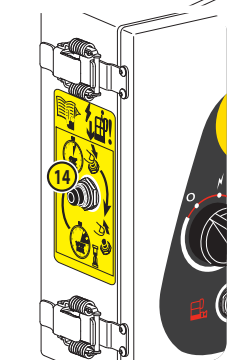
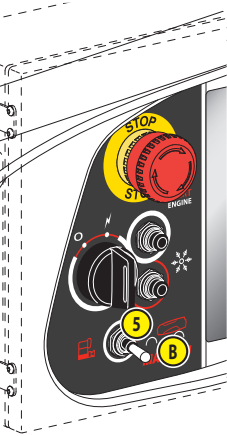

AMPLITUDE OF MOVEMENT - STANDARD WHEELS

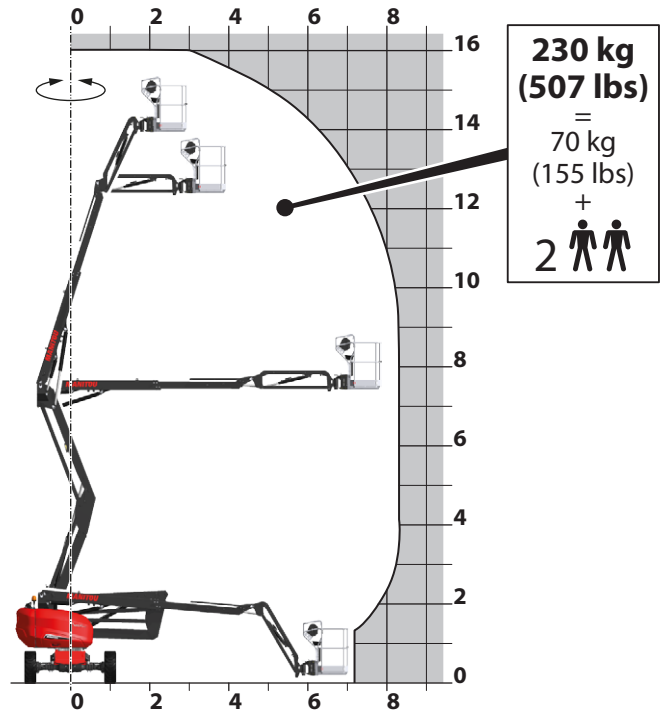

DAILY MAINTENANCE

1 - GENERAL INSPECTION

2 - FUEL LEVEL

3 - DIESEL ENGINE OIL LEVEL

4 - COOLANT LEVEL

5 - HYDRAULIC OIL LEVEL

6 - MACHINE OPERATION

