



**647122 EN (28/10/2024)**

**Rev. B**

M26/30-2 + H ST3B

M26/30-4 + H ST3B

M40/50-2 + H ST3B

M40/50-4 + H ST3B

4 Speed and Hydrostatic  
TRANSMISSION

**OPERATOR'S MANUAL**  
**(ORIGINAL INSTRUCTIONS)**

## IMPORTANT

*Carefully read and understand this instruction manual before using the lift truck.*

*It contains all information relating to operation, handling and lift truck equipment, as well as important recommendations to be followed.*

*This document also contains precautions for use, as well as information on the servicing and routine maintenance required to ensure the lift truck's continued safety of use and reliability.*

WHENEVER YOU SEE THIS SYMBOL IT MEANS:



**WARNING ! BE CAREFUL ! YOUR SAFETY OR THE SAFETY OF THE LIFT TRUCK IS AT RISK.**

- This manual has been produced on the basis of the equipment list and the technical characteristics given at the time of its design.
- The level of equipment of the lift truck depends on the options chosen and the country of sale.
- According to the lift truck options and the date of sale, certain items of equipment/functions described herein may not be available.
- Descriptions and figures are non binding.
- MANITOU reserves the right to change its models and their equipment without being required to update this manual.
- The MANITOU network, consisting exclusively of qualified professionals, is at your disposal to answer all your questions.
- This manual is an integral part of the lift truck.
- It is to be kept in its storage space at all times for ease of reference.
- Hand this manual to the new owner if the lift truck is resold.

## CALIFORNIA PROPOSITION 65 WARNINGS

### **WARNING**

This product can expose you to lead which is known to the State of California to cause cancer and birth defects or other reproductive harm.

For more information go to [www.P65Warnings.ca.gov](http://www.P65Warnings.ca.gov)

### **WARNING**

Breathing diesel engine exhaust exposes you to chemicals known to the State of California to cause cancer and birth defects or other reproductive harm.

- Always start and operate the engine in a well-ventilated area.
- If in an enclosed area, vent the exhaust to the outside.
- Do not modify or tamper with the exhaust system.
- Do not idle the engine except as necessary.

For more information go to [www.P65Warnings.ca.gov/diesel](http://www.P65Warnings.ca.gov/diesel)

## SILICA DUST HAZARD

Exposure to crystalline silica (found in sand, soil and rocks) has been associated with silicosis, a debilitating and often fatal lung disease. Comply with all applicable rules and regulations for the workplace. Wear approved respiratory protection or use water spray or other means if there is no other way to control the dust.

A Silica rule "29 CFR 1929.1153" by the U.S. Occupational Safety and Health (OSHA) indicates a significant risk of chronic silicosis for workers exposed to inhaled crystalline silica over a working lifetime. Refer to the rule for more information regarding exposure limits and hazard prevention.



1st ISSUE	02/07/2012
<b>UPDATED</b>	
02/07/2012	<b>1ST DATE OF ISSUE</b>
01/02/2013	<b>UP DATING</b>
15/01/2014	<b>ADDED M26-2/4 AND M40-2/4</b>
01/06/2014	<b>ADDED THE HYDROSTATIC TRANSMISSION</b>
30/07/16	<b>UPDATED</b>
01/04/2018	<b>UPDATED</b>
19/10/2020	<b>Added Maintenance light Reset Instructions</b>
28/10/2024	<b>3-5 - 3-7</b>

Manitou BF S.A Limited liability company with a Board of Directors.  
 Head office: 430, Rue de l'Aubinière - 44150 Ancenis - FRANCE  
 Share capital: 39,548,949 euros  
 857 802 508 RCS Nantes.  
 Tel: +33 (0)2 40 09 10 11  
 www.manitou.com

*This manual is for information purposes only. Any reproduction, copy, representation, recording, transfer, distribution, or other, in part or in whole, in any format is prohibited. The plans, designs, views, commentaries and instructions, even the document organization that are found in this document, are the intellectual property of MANITOU BF. Any violation of the aforementioned may lead to civil and criminal prosecution. The logos as well as the visual identity of the company are the property of MANITOU BF and may not be used without express and formal authorization. All rights are reserved.*

**1 - OPERATING AND SAFETY INSTRUCTIONS**

**2 - DESCRIPTION**

**3 - MAINTENANCE**

**4 - OPTIONAL ATTACHMENTS FOR USE WITH THE RANGE**

# ***1 - OPERATING AND SAFETY INSTRUCTIONS***

# TABLE OF CONTENTS

## 1 - OPERATING AND SAFETY INSTRUCTIONS

<b>INSTRUCTIONS TO THE COMPANY MANAGER</b>	<b>4</b>
<b>THE SITE</b>	<b>4</b>
<b>THE OPERATOR</b>	<b>4</b>
<b>THE LIFT TRUCK</b>	<b>4</b>
A - THE TRUCK'S SUITABILITY FOR THE JOB . . . . .	4
B - ADAPTATION OF THE LIFT TRUCK TO STANDARD ENVIRONMENTAL CONDITIONS . . . . .	4
C - MODIFICATION OF THE LIFT TRUCK . . . . .	5
D - FRENCH ROAD TRAFFIC RULES . . . . .	5
<b>THE INSTRUCTIONS</b>	<b>5</b>
<b>THE MAINTENANCE</b>	<b>5</b>
<b>INSTRUCTIONS FOR THE OPERATOR</b>	<b>6</b>
<b>PREAMBLE</b>	<b>6</b>
<b>GENERAL INSTRUCTIONS</b>	<b>6</b>
A - OPERATOR'S MANUAL . . . . .	6
B - AUTHORISATION FOR USE IN FRANCE . . . . .	6
C - MAINTENANCE . . . . .	6
D - MODIFICATION OF THE LIFT TRUCK . . . . .	6
E - LIFTING PEOPLE . . . . .	6
<b>OPERATING INSTRUCTIONS UNLADEN AND LADEN</b>	<b>7</b>
A - BEFORE STARTING THE LIFT TRUCK . . . . .	7
B - DRIVER'S OPERATING INSTRUCTIONS . . . . .	7
C - ENVIRONMENT . . . . .	7
D - VISIBILITY . . . . .	8
E - STARTING THE LIFT TRUCK . . . . .	8
F - DRIVING THE LIFT TRUCK . . . . .	9
G - STOPPING THE LIFT TRUCK . . . . .	10
H - DRIVING THE LIFT TRUCK ON THE PUBLIC HIGHWAY . . . . .	10
<b>INSTRUCTIONS FOR HANDLING A LOAD</b>	<b>11</b>
A - CHOICE OF ATTACHMENTS . . . . .	11
B - MASS OF LOAD AND CENTRE OF GRAVITY . . . . .	11
C - TRANSVERSE ATTITUDE OF THE LIFT TRUCK . . . . .	11
D - PICKING UP A LOAD ON THE GROUND . . . . .	12
E - PICKING UP AND LAYING DOWN A HIGH LOAD ON TIRES . . . . .	12
<b>MAINTENANCE INSTRUCTIONS OF THE LIFT TRUCK</b>	<b>14</b>
<b>GENERAL INSTRUCTIONS</b>	<b>14</b>
<b>MAINTENANCE</b>	<b>14</b>
<b>LUBRICANT AND FUEL LEVELS</b>	<b>14</b>
<b>HYDRAULIC</b>	<b>14</b>
<b>ELECTRICITY</b>	<b>14</b>
<b>WELDING</b>	<b>15</b>
<b>WASHING THE LIFT TRUCK</b>	<b>15</b>
<b>TRANSPORTING THE LIFT TRUCK</b>	<b>15</b>

<b><i>IF THE LIFT TRUCK IS NOT TO BE USED FOR A LONG TIME</i></b>	<b>16</b>
<b>INTRODUCTION</b>	<b>16</b>
<b>PREPARING THE LIFT TRUCK</b>	<b>16</b>
<b>PROTECTING THE ENGINE</b>	<b>16</b>
<b>PROTECTING THE LIFT TRUCK</b>	<b>16</b>
<b>BRINGING THE LIFT TRUCK BACK INTO SERVICE</b>	<b>17</b>
<b><i>LIFT TRUCK DISPOSAL</i></b>	<b>18</b>
<b>RECYCLING OF MATERIALS</b>	<b>18</b>
METALS . . . . .	18
PLASTICS . . . . .	18
RUBBER . . . . .	18
GLASS . . . . .	18
<b>ENVIRONMENTAL PROTECTION</b>	<b>18</b>
WORN OR DAMAGED PARTS . . . . .	18
USED OIL . . . . .	18
USED BATTERIES . . . . .	18
<b><i>WARRANTY &amp; PROPOSITION 65</i></b>	<b>19</b>

# INSTRUCTIONS TO THE COMPANY MANAGER

## THE SITE

- Proper management of lift truck's area of travel will reduce the risk of accidents:
  - Ground not unnecessarily uneven or obstructed,
  - No excessive slopes,
  - Pedestrian traffic controlled, etc.

## THE OPERATOR

- Only qualified, authorized personnel can use the lift truck. This authorization is given in writing by the appropriate person in the establishment with respect to the use of lift trucks and must be carried permanently by the operator.

### ⚠ IMPORTANT ⚠

*On the basis of experience, there are a number of possible situations in which operating the lift truck is contra-indicated. Such foreseeable abnormal uses, the main ones being listed below, are strictly forbidden.*

- *The foreseeable abnormal behavior resulting from ordinary neglect, but does not result from any wish to put the machinery to any improper use.*
- *The reflex reactions of a person in the event of a malfunction, incident, fault, etc. during operation of the lift truck.*
- *Behavior resulting from application of the "principle of least action" when performing a task.*

*- For certain machines, the foreseeable behavior of such persons as: apprentices, teenagers, handicapped persons, trainees tempted to drive a lift truck, operator tempted to operate a truck to win a bet, in competition or for their own personal experience.*

*The person in charge of the equipment must take these criteria into account when assessing whether or not a person will make a suitable driver.*

## THE LIFT TRUCK

### A - THE TRUCK'S SUITABILITY FOR THE JOB

- MANITOU has ensured that this lift truck is suitable for use under the standard operating conditions defined in this operator's manual, with a **STATIC test coefficient of 1.33** and a **DYNAMIC test coefficient of 1**, as specified in harmonized norm **EN 1726-1** for mast trucks.
- Before commissioning, the company manager must make sure that the lift truck is appropriate for the work to be done, and perform certain tests (in accordance with current legislation).

### B - ADAPTATION OF THE LIFT TRUCK TO STANDARD ENVIRONMENTAL CONDITIONS

- In addition to series equipment mounted on your lift truck, many options are available, such as: road lighting, stop lights, revolving light, reverse lights, reverse buzzer alarm, front light, rear light, etc.
- The operator must take into account the operating conditions to define the lift truck's signaling and lighting equipment. Contact your dealer.
- Take into account climatic and atmospheric conditions of the site of utilization.
  - Protection against frost (see: 3 - MAINTENANCE: LUBRICANTS AND FUEL).
  - Adaptation of lubricants (ask your dealer for information).
  - Engine filtration (see: 3 - MAINTENANCE: FILTERS CARTRIDGES AND BELTS).

### ⚠ IMPORTANT ⚠

*For operation under average climatic conditions, i.e.: between -15 °C and +35 °C, correct levels of lubricants in all the circuits are checked in production.*

*For operation under more severe climatic conditions, before starting up, it is necessary to drain all the circuits, then ensure correct levels of lubricants properly suited to the relevant ambient temperatures.*

*It is the same for the cooling liquid.*

- A lift truck operating in an area without fire extinguishing equipment must be equipped with an individual extinguisher. There are solutions, consult your dealer.

### ⚠ IMPORTANT ⚠

*Your lift truck is designed for outdoor use under normal atmospheric conditions and indoor use in suitably aerated and ventilated premises.*

*It is prohibited to use the lift truck in areas where there is a risk of fire or which are potentially explosive (e.g. Refineries, fuel or gas depots, stores of inflammable products...).*

*For use in these areas, specific equipment is available (ask your dealer for information).*

- Our trucks comply with Directive 2004/108/EC concerning electromagnetic compatibility (EMC), and with the corresponding harmonized standard EN 12895. Their proper operation is no longer guaranteed if they are used within areas in which the electromagnetic fields exceed the limit specified by that standard (10 V/m).
- Directive 2002/44/EC requires company managers to not expose their employees to excessive vibration doses. There is no recognized code of measurement for comparing the machines of different manufacturers. The actual doses received cannot therefore be measured under actual operating conditions at the user's premises.

- The following are some tips for minimizing these vibration doses:
  - Select the most suitable lift truck and attachment for the intended use.
  - Adapt the seat adjustment to the operator's weight (according to lift truck model) and maintain it in good condition, as well as the cab suspension. Inflate the tires in accordance with recommendations.
  - Ensure that the operators adapt their operating speed to suit the conditions on site.
  - As far as possible, arrange the site in such a way as to provide a flat running surface and remove obstacles and harmful potholes.

### C - MODIFICATION OF THE LIFT TRUCK

- For your own safety and that of others, you must not change the structure and settings of the various components used in your lift truck by yourself (hydraulic pressure, limiter calibration, engine speed, addition of extra equipment, addition of counterweights, unapproved attachments, alarm systems, etc.). In this event, the manufacturer cannot be held liable.

### D - FRENCH ROAD TRAFFIC RULES

- Only one certificate of conformity is issued. It must be kept in a safe place.
- The driving of non-approved lift trucks on the public highway is subject to the provisions of the highway code relating to special machines, defined in article R311-1 of the highway code, in category B of the Equipment Order of 20 November 1969 that determines the procedures applicable to special machines. The lift truck must be fitted with a license plate.

## THE INSTRUCTIONS

- The operator's manual must always be in good condition and kept in the place provided on the lift truck and in the language used by the operator.
- The operator's manual and any plates or stickers which are no longer legible or are damaged, must be replaced immediately.

## THE MAINTENANCE

- Maintenance or repairs other than those detailed in part: 3 - MAINTENANCE must be carried out by qualified personnel (consult your dealer) and under the necessary safety conditions to maintain the health of the operator and any third party.

### **⚠ IMPORTANT ⚠**

*Your lift truck must be inspected periodically to ensure that it remains in compliance.  
The frequency of this inspection is defined by current legislation in the country in which the lift truck is used.*

- Example for France "The manager in charge of the establishment using a lift truck must open and maintain a maintenance log for each machine (order of 2 March 2004) and undergo a general periodic inspection every 6 months (order of 1 March 2004)".

# INSTRUCTIONS FOR THE OPERATOR

## PREAMBLE

### **⚠ IMPORTANT ⚠**

*The risk of accident while using, servicing or repairing your lift truck can be restricted if you follow the safety instructions and safety measures detailed in these instructions.*

*Failure to respect the safety and operating instructions, or instructions for repairing or servicing your lift truck, may lead to serious, even fatal accident.*

*In order to reduce or avoid any danger with a MANITOU-approved attachment, follow the instructions of paragraph: 4 - ADAPTABLE ATTACHMENTS IN OPTION ON THE RANGE: INTRODUCTION.*

- Only the operations and maneuvers described in this operator's manual must be performed. The manufacturer cannot predict all possible risky situations. Consequently, the safety instructions given in the operator's manual and on the lift truck itself are not exhaustive.
- At any time, as an operator, you must envisage, within reason, the possible risk to yourself, to others or to the lift truck itself when you use it.

## GENERAL INSTRUCTIONS

### A - OPERATOR'S MANUAL

- Read the operator's manual carefully.
- The operator's manual must always be in good condition and in the place provided for it on the lift truck.
- You must report any plates and stickers which are no longer legible or which are damaged.

### B - AUTHORISATION FOR USE IN FRANCE

*(or see current legislation in other countries)*

- Only qualified, authorized personnel can use the lift truck. This authorization is given in writing by the appropriate person in the establishment with respect to the use of lift trucks and must be carried permanently by the operator.
- The operator is not competent to authorize the driving of the lift truck by another person.

### C - MAINTENANCE

- The operator must immediately advise his superior if his lift truck is not in good working order or does not comply with the safety notice.
- The operator is prohibited from carrying out any repairs or adjustments himself, unless he has been trained for this purpose. He must keep the lift truck properly cleaned if this is among his responsibilities.
- The operator must carry out daily maintenance (see: 3 - MAINTENANCE: A - DAILY OR EVERY 10 HOURS SERVICE).
- The operator must ensure tires are adapted to the nature of the ground (see area of the contact surface of the tires in the chapter: 2 - DESCRIPTION: FRONT AND REAR TYRES). There are optional solutions, consult your dealer.
  - SAND tires.
  - LAND tires.
  - Snow chains.

### **⚠ IMPORTANT ⚠**

*Do not use the lift truck if the tires are incorrectly inflated, damaged or excessively worn, because this could put your own safety or that of others at risk, or cause damage to the lift truck itself.*

*The fitting of foam inflated tires is prohibited and is not guaranteed by the manufacturer, excepting prior authorization.*

### D - MODIFICATION OF THE LIFT TRUCK

- For your own safety and that of others, you must not change the structure and settings of the various components used in your lift truck by yourself (hydraulic pressure, limiter calibration, engine speed, addition of extra equipment, addition of counterweights, unapproved attachments, alarm systems, etc.). In this event, the manufacturer cannot be held liable.

### E - LIFTING PEOPLE

- The use of working equipment and load lifting attachments to lift people is:
  - Either forbidden
  - Or authorized exceptionally and under certain conditions (see current regulations in the country in which the lift truck is used).

**A - BEFORE STARTING THE LIFT TRUCK**

- Perform the daily service (see: 3 - MAINTENANCE: A - DAILY OR EVERY 10 HOURS SERVICE).
- Make sure the lights, indicators and windscreen wipers are working properly.
- Make sure the rear view mirrors are in good condition, clean and properly adjusted.
- Make sure the horn works.

**B - DRIVER'S OPERATING INSTRUCTIONS**



*Under no circumstances must the seat be adjusted while the lift truck is moving.*

- Whatever his experience, the operator is advised to familiarize himself with the position and operation of all the controls and instruments before operating the lift truck.
- Wear clothes suited for driving the lift truck, avoid loose clothes.
- Make sure you have the appropriate protective equipment for the task to be performed.
- Prolonged exposure to high noise levels may cause hearing problems. It is recommended to wear ear muffs to protect against excessive noise.
- Always face the lift truck when getting into and leaving the driving seat and use the handle(s) provided for this purpose. Do not jump out of the seat to get down.
- Always pay attention when using the lift truck. Do not listen to the radio or music using headphones or earphones.
- Never operate the lift truck when hands or feet are wet or soiled with greasy substances.
- For increased comfort, adjust the seat to your requirements and adopt the correct position in the driver's cab.
- The operator must always be in his normal position in the driver's cab. It is prohibited to have arms or legs, or generally any part of the body, protruding from the driver's cab of the lift truck.
- The safety belt must be worn and adjusted to the operator's size.
- The control units must never in any event be used for any other than their intended purposes (e.g. climbing onto or down from the lift truck, portmanteau, etc.).
- If the control components are fitted with a forced operation (lever lock) device, it is forbidden to leave the cab without first putting these controls in neutral.
- It is prohibited to carry passengers either on the lift truck or in the cab.

**C - ENVIRONMENT**

- Comply with site safety regulations.
- If you have to use the lift truck in a dark area or at night, make sure it is equipped with working lights.
- During handling operations, make sure that no one is in the way of the lift truck and its load.
- Do not allow anybody to come near the working area of the lift truck or pass beneath an elevated load.
- When using the lift trucks on a transverse slope, before lifting the mast, follow the instructions given in the paragraph: INSTRUCTIONS FOR HANDLING A LOAD: C - TRANSVERSE ATTITUDE OF THE LIFT TRUCK.
- Travelling on a longitudinal slope:
  - Drive and brake gently.

- Moving without load: Forks or attachment facing downhill.



- Moving with load: Forks or attachment facing uphill.

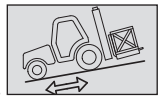

- Take into account the lift truck's dimensions and its load before trying to negotiate a narrow or low passageway.
- Never move onto a loading platform without having first checked:
  - That it is suitably positioned and made fast.
  - That the unit to which it is connected (wagon, lorry, etc.) will not shift.
  - That this platform is prescribed for the total weight of the lift truck to be loaded.
  - That this platform is prescribed for the size of the lift truck.
- Never move onto a foot bridge, floor or freight lift, without being certain that they are prescribed for the weight and size of the lift truck to be loaded and without having checked that they are in sound working order.
- Be careful in the area of loading bays, trenches, scaffolding, soft ground and manholes.
- Make sure the ground is stable and firm under the wheels before lifting the load.
- Make sure that the scaffolding, loading platform, pilings or ground is capable of bearing the load.

- Never stack loads on uneven ground, they may tip over.
- The load or the attachment must not be left just above a structure for long periods at a time because of the descending mast. In such a case, a constant watch must be kept and the height of the forks or the attachment readjusted if necessary.
- When working near aerial lines, ensure that the safety distance is sufficient between the working area of the lift truck and the aerial line.

**⚠ IMPORTANT ⚠**

*You must consult your local electrical agency.*

*You could be electrocuted or seriously injured if you operate or park the lift truck too close to power cables.*

*In the event of high winds, do not carry out handling work that jeopardizes the stability of the lift truck and its load, particularly if the load catches the wind badly.*

## D - VISIBILITY

- The safety of people within the lift truck's working area, as well as that of the lift truck itself and the operator are depend on good operator visibility of the lift truck's immediate vicinity in all situations and at all times.
- This lift truck has been designed to allow good operator visibility (direct or indirect by means of rear-view mirrors) of the immediate vicinity of the lift truck while traveling with no load and with the mast in the transport position.
- Special precautions must be taken if the size of the load restricts visibility towards the front:
  - Moving in reverse,
  - Site layout,
  - Assisted by a person directing the maneuver (while standing outside the truck's area of travel), making sure to keep this person clearly in view at all times,
  - In any event, avoid reversing over long distances.
- If visibility of your road is inadequate, ask someone to assist by directing the maneuver (while standing outside the truck's area of travel), making sure to keep this person clearly in view at all times.
- Keep all components affecting visibility in a clean, properly adjusted state and in good working order (e.g. windscreens, windows, windscreen wipers, windscreen washers, driving and work lights, rear-view mirrors).

## E - STARTING THE LIFT TRUCK

### SAFETY INSTRUCTIONS

**⚠ IMPORTANT ⚠**

*The lift truck must only be started up or maneuvered when the operator is sitting in the driver's cab, with his seat belt adjusted and fastened.*

- Never try to start the lift truck by pushing or towing it. Such operation may cause severe damage to the transmission. If necessary, to tow the lift truck in an emergency, the transmission must be placed in the neutral position (see: 3 - MAINTENANCE: G - OCCASIONAL MAINTENANCE).
- If using an emergency battery for start-up, use a battery with the same characteristics and respect battery polarity when connecting it. Connect at first the positive terminals before the negative terminals.

**⚠ IMPORTANT ⚠**

*Failure to respect polarity between batteries can cause serious damage to the electrical circuit.*

*The electrolyte in the battery may produce an explosive gas. Avoid flames and generation of sparks close to the batteries.*

*Never disconnect a battery while it is charging.*

### INSTRUCTIONS

- Check the closing and locking of the hood(s).
- For lift trucks operating on gas carburization, open the gas bottle.
- Ensure that the forward/reverse selector is set to neutral.
- Turn the ignition key to the position I to activate the electrical and pre-heating system.
- Check the fuel level on the indicator.
- Turn the ignition key fully, the engine should then start. Release the ignition key and let the engine run at idle.
- Do not engage the starter motor for more than 15 seconds and carry out the preheating between unsuccessful attempts.
- Make sure all the signal lights on the control instrument panel are off.
- Check all control instruments when the engine is warm and at regular intervals during use, so as to quickly detect any faults and to be able to correct them without any delay.
- If an instrument does not show the correct display, stop the engine and immediately carry out the necessary operations.

## F - DRIVING THE LIFT TRUCK

### SAFETY INSTRUCTIONS

#### **⚠ IMPORTANT ⚠**

*Operators' attention is drawn to the risks involved in using the lift truck, in particular:*

*- Risk of losing control.*

*- Risk of losing lateral and frontal stability of the lift truck.*

*The operator must remain in control of the lift truck.*

*In the event of the lift truck overturning, do not try to leave the cabin during the incident.*

**YOUR BEST PROTECTION IS TO STAY FASTENED IN THE CABIN.**

- Observe the company's traffic regulations or, by default, the public highway code.
- Do not carry out operations which exceed the capacities of your lift truck or attachments.
- Always drive the lift truck with the forks or attachment to the transport position, i.e. at 300mm from the ground and the carriage sloping backwards.
- Only carry loads which are balanced and properly anchored to avoid any risk of a load falling off.
- Ensure that palletes, cases, etc., are in good order and suitable for the load to be lifted.
- Familiarize yourself with the lift truck on the terrain where it will be used.
- Ensure that the service brakes are working properly.
- The loaded lift truck must not travel at speeds in excess of 12km/h.
- Drive smoothly at an appropriate speed for the operating conditions (land configuration, load on the lift truck).
- Do not use the hydraulic mast controls when the lift truck is moving.
- Do not maneuver the lift truck with the mast in the raised position unless under exceptional circumstances and then with extreme caution, at very low speed and using gentle braking. Ensure that visibility is adequate.
- Take bends slowly.
- In all circumstances make sure you are in control of your speed.
- On damp, slippery or uneven terrain, drive slowly.
- Brake gently, never abruptly.
- Only use the lift truck's forward/reverse selector from a stationary position and never do so abruptly.
- Do not drive with your foot on the brake pedal.
- Always remember that hydrostatic type steering is extremely sensitive to movement of the steering wheel, so turn it gently and not jerkily.
- Never leave the I.C. engine on when the lift truck is unattended.
- Do not leave the cab when the lift truck has a raised load.
- Look where you are going and always make sure you have good visibility along the route.
- Use the rear-view mirrors frequently.
- Drive round obstacles.
- Never drive on the edge of a ditch or steep slope.
- It is dangerous to use two lift trucks simultaneously to handle heavy or voluminous loads, since this operation requires particular precautions to be taken. It must only be used exceptionally and after risk analysis.
- The ignition switch has an emergency stop mechanism in case of an operating anomaly occurring in the case of lift trucks not fitted with a punch-operated cut-out.

### INSTRUCTIONS

- Always drive the lift truck with the forks or attachment to the transport position, i.e. at 300mm from the ground and the carriage sloping backwards.
- For lift trucks with gearboxes, select the chosen gear (see: 2 - DESCRIPTION: INSTRUMENTS AND CONTROLS).
- Release the hand brake.
- Shift the forward/reverse selector to the selected direction of travel and accelerate gradually until the lift truck moves off.

## G - STOPPING THE LIFT TRUCK

### SAFETY INSTRUCTIONS

- Never leave the ignition key in the lift truck during the operator's absence.
- When the lift truck is stationary, or if the operator has to leave his cab (even for a moment), place the forks or attachment on the ground, apply the parking brake and place the forward/reverse selector in neutral.
- Make sure that the lift truck is not stopped in any position that will interfere with the traffic flow and at less than one meter from the track of a railway.
- In the event of prolonged parking on a site, protect the lift truck from bad weather, particularly from frost (check the level of antifreeze), close and lock all the lift truck accesses (doors, windows, cowl, etc.).

### INSTRUCTIONS

- Park the lift truck on flat ground or on an incline lower than 15%.
- Set the forward/reverse selector to neutral.
- Engage the parking brake.
- For lift trucks with gearboxes, place the gear lever in neutral.
- Lower the forks or attachment to rest on the ground.
- When using an attachment with a grab or jaws, or a bucket with hydraulic opening, close the attachment fully.
- Before stopping the lift truck after a long working period, leave the I.C. engine idling for a few moments, to allow the coolant liquid and oil to lower the temperature of the I.C. engine and transmission. Do not forget this precaution, in the event of frequent stops or warm stalling of the I.C. engine, or else the temperature of certain parts will rise significantly due to the stopping of the cooling system, with the risk of badly damaging such parts.
- Stop the engine with the ignition switch.
- Remove the ignition key.
- Lock all the accesses to the lift truck (doors, windows, cowl...).
- For lift trucks operating on gas carburization, shut the LPG bottle. For a long lasting stop, let the engine stop naturally by shutting the LPG bottle before switching off the ignition, so as to eliminate all the fuel in the feed tube.

## H - DRIVING THE LIFT TRUCK ON THE PUBLIC HIGHWAY

### FRENCH ROAD TRAFFIC RULES

- The driving of non-approved lift trucks on the public highway is subject to the provisions of the highway code relating to special machines, defined in article R311-1 of the highway code, in category B of the Equipment Order of 20 November 1969 that determines the procedures applicable to special machines. The lift truck must be fitted with a license plate.

### SAFETY INSTRUCTIONS

- Operators driving on the public highway must comply with current highway code legislation.
- The lift truck must comply with current road legislation. If necessary, there are optional solutions. Contact your dealer.

### INSTRUCTIONS

- Make sure the revolving light is in place, switch it on and verify its operation.
- Make sure the lights, indicators and windscreen wipers are working properly.
- Switch off the working headlights if the lift truck is fitted with them.
- Place the attachment 300mm from the ground.

### **⚠ IMPORTANT ⚠**

***Never move in neutral (forward/reverse selector or gear lever in neutral or transmission cut-off button pressed) to preserve the lift truck engine brake. Failure to respect this instruction on a slope will lead to excessive speed which may make the lift truck uncontrollable (steering, brakes) and cause serious mechanical damage.***

## DRIVING THE LIFT TRUCK WITH A FRONT-MOUNTED ATTACHMENT

- You must comply with current regulations in your country, covering the possibility of driving on the public highway with a front-mounted attachment on your lift truck.
- If road legislation in your country authorizes circulation with a front-mounted attachment, you must at least:
  - Protect and report any sharp and/or dangerous edges on the attachment (see: 4 - ADAPTABLE ATTACHMENTS IN OPTION ON THE RANGE: ATTACHMENT SHIELDS).
  - The attachment must not be loaded.
  - Make sure that the attachment does not mask the lighting range of the forward lights.
  - Make sure that current legislation in your country does not require other obligations.

## OPERATING THE LIFT TRUCK WITH A TRAILER

- For using a trailer, observe the regulations in force in your country (maximum travel speed, braking, maximum weight of trailer, etc.).
- Do not forget to connect the trailer's electrical equipment to that of the lift truck.
- The trailer's braking system must comply with current legislation.
- If pulling a trailer with assisted braking, the tractor lift truck must be equipped with a trailer braking mechanism. In this case, do not forget to connect the trailer braking equipment to the lift truck.
- The vertical force on the towing hook must not exceed the maximum authorized by the manufacturer (consult the manufacturer's plate on your lift truck).
- The authorized gross vehicle weight must not exceed the maximum weight authorized by the manufacturer (consult the manufacturer's plate on your lift truck).

**IF NECESSARY, CONSULT YOUR DEALER.**

## **INSTRUCTIONS FOR HANDLING A LOAD**

### **A - CHOICE OF ATTACHMENTS**

- Only attachments approved by MANITOU can be used on its lift trucks.
- Make sure the attachment is appropriate for the work to be done (see: 4 - ADAPTABLE ATTACHMENTS IN OPTION ON THE RANGE).
- Make sure the attachment is correctly installed and locked onto the lift truck carriage.
- Make sure that your lift truck attachments work properly.
- Comply with the load chart limits for the lift truck for the attachment used.
- Do not exceed the rated capacity of the attachment.
- Never lift a load in a sling without the attachment provided for the purpose. There are optional solutions; contact your dealer.

### **B - MASS OF LOAD AND CENTRE OF GRAVITY**

- Before taking up a load, you must know its mass and its center of gravity.
- The load chart for your lift truck is valid for a load in which the longitudinal position of the center of gravity is 500mm or 600mm from the base of the forks (according to the model of lift truck) (fig. B1). For a higher center of gravity, contact your dealer.
- For irregular loads, determine the transverse center of gravity before any movement (fig. B2) and set it in the longitudinal axis of the lift truck.

**⚠ IMPORTANT ⚠**

*It is forbidden to move a load heavier than the effective capacity defined on the lift truck load chart.*

*For loads with a moving center of gravity (e.g. liquids), take account of the variations in the center of gravity in order to determine the load to be handled and be vigilant and take extra care to limit these variations as far as possible.*

### **C - TRANSVERSE ATTITUDE OF THE LIFT TRUCK.**

The transverse attitude is the transverse slope of the chassis with respect to the horizontal.

Raising the mast reduces the lift truck's lateral stability. The transverse attitude must be set with the mast in down position as follows:

- Position the lift truck so that the bubble in the level is between the two lines (see: 2 - DESCRIPTION: INSTRUMENTS AND CONTROLS).

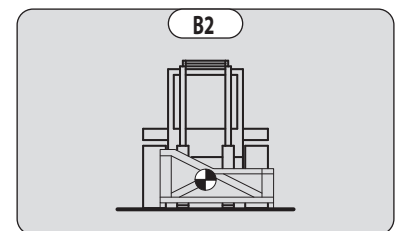
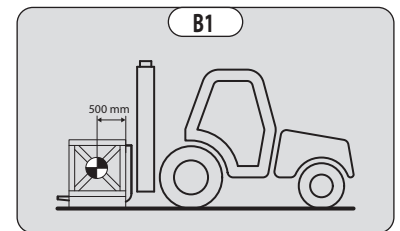

## D - PICKING UP A LOAD ON THE GROUND

- Approach the lift truck perpendicular to the load, with the forks in a horizontal position (fig. D1).
- Adjust the spread and centering of the forks relative to the load to ensure its stability (fig. D2) (optional solutions exist, consult your dealer).
- Never lift a load with a single fork.

### ⚠ IMPORTANT ⚠

*Beware of the risks of trapping or crushing limbs when manually adjusting the forks.*

- Move the lift truck forward slowly (1) and bring the forks to stop in front of the load (fig. D3), if necessary, slightly lift the mast (2) while taking up the load.
- Bring the load into the transport position.
- Tilt the load far enough backwards to ensure stability (loss of load on braking or going downhill).

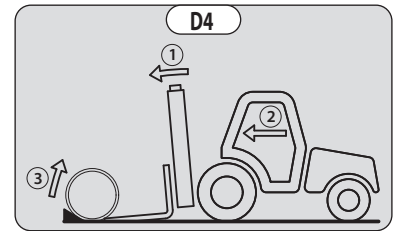
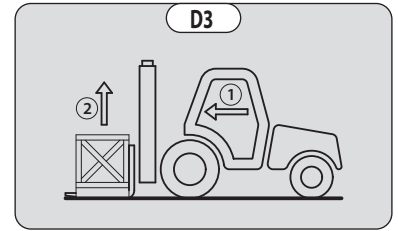
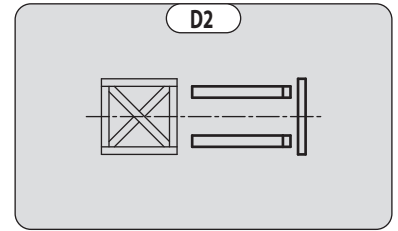
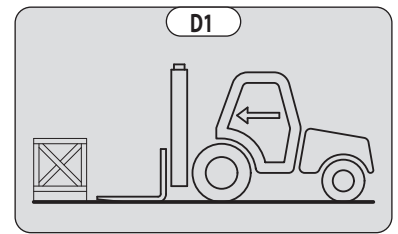

## FOR A NON-PALLETISED LOAD

- Tilt the carriage (1) forwards and move the lift truck slowly forwards (2), to insert the fork under the load (fig. D4) (block the load if necessary).
- Continue to move the lift truck forwards (2) tilting the carriage (3) (fig. D4) backwards to position the load on the forks and check the load's longitudinal and lateral stability.

## E - PICKING UP AND LAYING DOWN A HIGH LOAD ON TIRES

### ⚠ IMPORTANT ⚠

*You must not raise the mast if you have not checked the transverse attitude of the lift truck (see: INSTRUCTIONS FOR HANDLING A LOAD: C - TRANSVERSE ATTITUDE OF THE LIFT TRUCK).*

REMINDER: Make sure that the following operations can be performed with good visibility (see: OPERATIONS INSTRUCTIONS UNLADEN AND LADEN: D - VISIBILITY).

## PICKING UP A HIGH LOAD ON TIRES

- Ensure that the forks will easily pass under the load.
- Keeping the mast vertical (1), advance the lift truck and raise the forks to level with the load (2) (fig. E1).
- Maneuver carefully and gently to bring the forks to the stop in front of the load (fig. E2). Set the handbrake and place the forward/reverse selector to neutral.

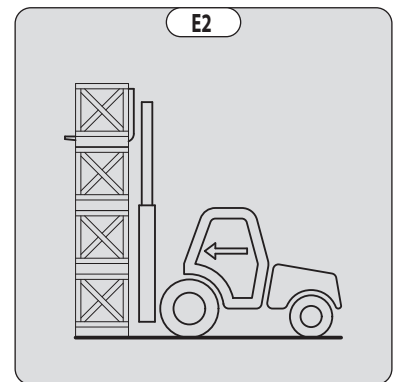
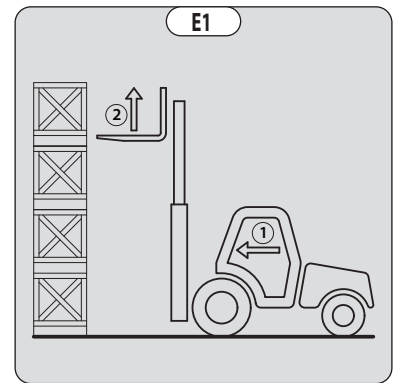

- Slightly lift the load (1) and incline the carriage (2) backwards to stabilize the load (fig. E3).
- Tilt the load sufficiently backwards to ensure its stability.
- Reverse the lift truck (1) very carefully and gently to free the load. Lower the mast (2) to bring the load into transport position (fig. E4).

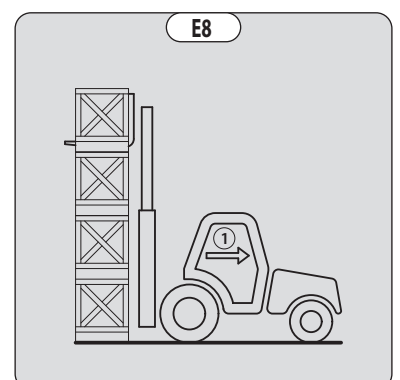
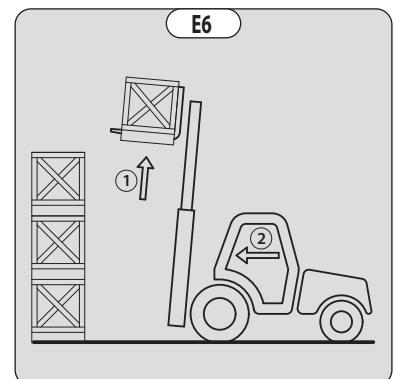
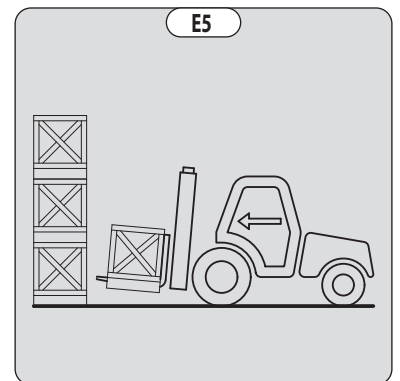
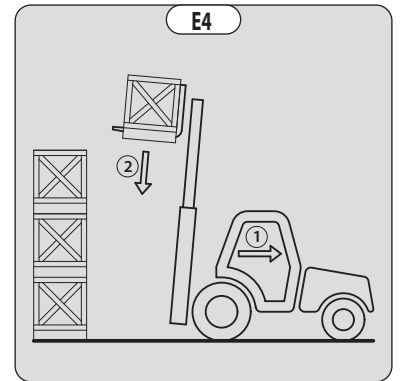
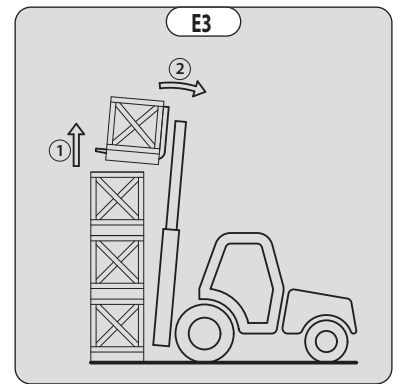

#### LAYING A HIGH LOAD ON TYRES

- Approach the load in the transport position in front of the pile (fig. E5).
- Raise the mast (1) until the load is higher than the pile and move the lift truck forward (2) (fig. E6) very carefully and gently, until the load is over the pile. Put the handbrake on and set the forward/reverse selector to neutral.
- Place the load in a horizontal position by tilting the mast forwards (1) and lay it down on the pile (2) while checking the correct positioning of the load (fig. E7).
- Reverse the lift truck (1) very slowly and carefully to release the forks (fig. E8). Then set them into transport position.

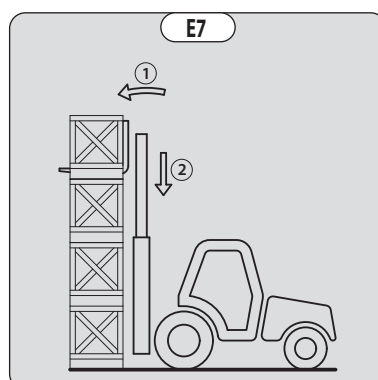

# MAINTENANCE INSTRUCTIONS OF THE LIFT TRUCK

## GENERAL INSTRUCTIONS

---

- Ensure the area is sufficiently ventilated before starting the lift truck.
- Wear clothes suitable for the maintenance of the lift truck, avoid wearing jewelry and loose clothes. Tie and protect your hair, if necessary.
- Stop the engine and remove the ignition key, when an intervention is necessary.
- Read the operator's manual carefully.
- Carry out all repairs immediately, even if the repairs concerned are minor.
- Repair all leaks immediately, even if the leak concerned is minor.
- Make sure that the disposal of process materials and of spare parts is carried out in total safety and in an ecological way.
- Be careful of the risk of burning and splashing (exhaust, radiator, engine, etc.).

## MAINTENANCE

---

- Perform the periodic service (see: 3 - MAINTENANCE) to keep your lift truck in good working conditions. Failure to perform the periodic service may cancel the contractual guarantee.

### MAINTENANCE LOGBOOK

- The maintenance operations carried out in accordance with the recommendations given in part: 3 - MAINTENANCE and the other inspection, servicing or repair operations or modifications performed on the lift truck or its attachments shall be recorded in a maintenance logbook. The entry for each operation shall include details of the date of the works, the names of the individuals or companies having performed them, the type of operation and its frequency, if applicable. The part numbers of any lift truck items replaced shall also be indicated.

## LUBRICANT AND FUEL LEVELS

---

- Use the recommended lubricants (never use contaminated lubricants).
- Do not fill the fuel tank when the engine is running.
- Only fill up the fuel tank in areas specified for this purpose.
- Do not fill the fuel tank to the maximum level.
- Do not smoke or approach the lift truck with a flame, when the fuel tank is open or is being filled.

## HYDRAULIC

---

- Any work on the load handling hydraulic circuit is forbidden except for the operations described in part: 3 - MAINTENANCE.
- Do not attempt to loosen couplings, hoses or any hydraulic component with the circuit under pressure.

### **⚠ IMPORTANT ⚠**

*It is dangerous to change the setting and remove the BALANCING VALVES or SAFETY VALVES which may be fitted to your lift truck cylinders.*

*The HYDRAULIC ACCUMULATORS that may be fitted on your lift truck are pressurized units.*

*Removing these accumulators and their pipework is dangerous.*

*Such operations must only be performed by approved personnel (consult your dealer).*

## ELECTRICITY

---

- Do not short-circuit the starter relay to start the engine. If the forward/reverse selector is not in neutral and the parking brake is not applied, the lift truck may suddenly start to move.
- Do not place metal items on the battery.
- Disconnect the battery before working on the electrical circuit.

## **WELDING**

---

- Disconnect the battery before any welding operations on the lift truck.
- When carrying out electric welding work on the lift truck, connect the negative cable from the equipment directly to the part being welded, so as to avoid high tension current passing through the alternator.
- Never carry out welding or work which gives off heat on an assembled tire. The heat would increase the pressure which could cause the tire to explode.
- If the lift truck is equipped with an electronic control unit, disconnect this before starting to weld, to avoid the risk of causing irreparable damage to electronic components.

## **WASHING THE LIFT TRUCK**

---

- Clean the lift truck or at least the area concerned before any intervention.
- Remember to close and lock all accesses to the lift truck (doors, windows, cowls...).
- During washing, avoid the articulations and electrical components and connections.
- If necessary, protect against penetration of water, steam or cleaning agents, components susceptible of being damaged, particularly electrical components and connections and the injection pump.
- Clean the lift truck of any fuel, oil or grease trace.

## **TRANSPORTING THE LIFT TRUCK**

---

### **⚠ IMPORTANT ⚠**

*Transporting the lift truck involves real risks for the operator and others involved.*

- Towing, slinging or transporting the lift truck (see 3 - MAINTENANCE: H - OCCASIONAL MAINTENANCE).

# IF THE LIFT TRUCK IS NOT TO BE USED FOR A LONG TIME

## INTRODUCTION

---

The following recommendations are intended to prevent the lift truck from being damaged when it is withdrawn from service for an extended period.

For these operations, we recommend the use of a MANITOU protective product, reference 603726.

Instructions for using the product are given on the packaging.

### **⚠ IMPORTANT ⚠**

*Procedures to follow if the lift truck is not to be used for a long time and for starting it up again afterwards must be performed by your dealership.*

## PREPARING THE LIFT TRUCK

---

- Clean the lift truck thoroughly.
- Check and repair any leakage of fuel, oil, water or air.
- Replace or repair any worn or damaged parts.
- Wash the painted surfaces of the lift truck in clear and cold water and wipe them.
- Touch up the paintwork if necessary.
- Shut down the lift truck (see: OPERATING INSTRUCTIONS UNLADEN AND LADEN).
- Make sure the mast cylinder rods are all in retracted position.
- Release the pressure in the hydraulic circuits.

## PROTECTING THE ENGINE

---

- Fill the tank with fuel (see: 3 - MAINTENANCE: A - DAILY OR EVERY 10 HOURS SERVICE).
- Empty and replace the cooling liquid (see: 3 - MAINTENANCE: F - EVERY 2000 HOURS SERVICE).
- Leave the I.C. engine running at idling speed for a few minutes, then switch off.
- Replace the I.C. engine oil and oil filter (see: 3 - MAINTENANCE: D - EVERY 500 HOURS SERVICE).
- Add the protective product to the engine oil.
- Run the I.C. engine for a short time so that the oil and cooling liquid circulate inside.
- Disconnect the battery and store it in a safe place away from the cold, after charging it to a maximum.
- Remove the injectors and spray the protective product into each cylinder for two seconds with the piston in low neutral position.
- Turn the crankshaft once slowly and refit the injectors (see I.C. engine REPAIR MANUAL).
- Remove the intake hose from the manifold or turbocharger and spray the protective product into the manifold or turbocharger.
- Cap the intake manifold or turbocharger hole with waterproof adhesive tape.
- Remove the exhaust pipe and spray the protective product into the exhaust manifold or turbocharger.
- Refit the exhaust pipe and block the outlet with waterproof adhesive tape.

NOTE: The spray time is noted on the product packaging and must be increased by 50% for turbo engines.

- Open the filler plug, spray the protective product around the rocker arm shaft and refit the filler plug.
- Cap the fuel tank using waterproof adhesive tape.
- Remove the drive belts and store them in a safe place.
- Disconnect the engine cut-off solenoid on the injection pump and carefully insulate the connection.

## PROTECTING THE LIFT TRUCK

---

- Set the lift truck on axle stands so that the tires are not in contact with the ground and release the handbrake.
- Protect cylinder rods which will not be retracted, from corrosion.
- Wrap the tires.

NOTE: If the lift truck is to be stored outdoors, cover it with a waterproof tarpaulin.

## **BRINGING THE LIFT TRUCK BACK INTO SERVICE**

---

- Remove the waterproof adhesive tape from all the holes.
- Refit the intake hose.
- Refit and reconnect the battery.
- Remove the protection from the cylinder rods.
- Perform the daily service (see: 3 - MAINTENANCE: A - DAILY OR EVERY 10 HOURS SERVICE).
- Put the handbrake on and remove the axle stands.
- Empty and replace the fuel and replace the fuel filter (see: 3 - MAINTENANCE: D - EVERY 500 HOURS SERVICE).
- Refit and set the tension in the drive belts (see: 3 - MAINTENANCE: C - EVERY 250 HOURS SERVICE).
- Turn the I.C. engine using the starter, to allow the oil pressure to rise.
- Reconnect the engine cut-off solenoid.
- Lubricate the lift truck completely (see: 3 - MAINTENANCE: SERVICING SCHEDULE).

### **⚠ IMPORTANT ⚠**

*Ensure the area is sufficiently ventilated before starting the lift truck.*

- Start up the lift truck, following the safety instructions and regulations (see: OPERATING INSTRUCTIONS UNLADEN AND LADEN).
- Run all the mast's hydraulic movements, concentrating on the ends of travel for each cylinder.

# LIFT TRUCK DISPOSAL

MANITOU complies with the regulations deriving from Directive 2000/53/EC relating to lift truck end-of-life. This lift truck contains no substances or materials forbidden by Directive 2000/53/EC.

NOTE: Consult your dealer before disposing of your lift truck.

## RECYCLING OF MATERIALS

---

### METALS

- Metals are 100% recoverable and recyclable.

### PLASTICS

- Plastic parts are identified with a marking in accordance with current regulations.
- A limited range of materials is used to simplify the recycling process.
- The majority of plastic components are made of "thermoplastic" plastics, that are easily recycled by melting, granulating or grinding.

### RUBBER

- Tires and seals can be ground for use in cement manufacture or to obtain reusable granules.

### GLASS

- Glass items can be removed and collected for processing by glaziers.

## ENVIRONMENTAL PROTECTION

---

By entrusting the maintenance of your lift truck to the MANITOU network, the risk of pollution is limited and the contribution to environmental protection contribution is made.

### WORN OR DAMAGED PARTS

- Do not dump them in the countryside.
- MANITOU and its network have signed-up to a scheme of environmental protection through recycling.

### USED OIL

- The MANITOU network organizes the collection and processing of used oil products.
- By handing over your waste oil to MANITOU, the risk of pollution is limited.

### USED BATTERIES

- Do not throw away batteries, as they contain metals that are harmful for the environment.
- Return them to the MANITOU network or any other approved collection point.

NOTE: MANITOU aims to manufacture lift trucks that provide the best performance and limit polluting emissions.



## NEW LIFT TRUCK

### WARRANTY AND LIMITATIONS OF LIABILITY

#### COVERAGE PROVIDED:

Manitou Americas, Inc. (Manitou) warrants every part of the lift trucks manufactured by it to be free under normal use and service from defects in material and workmanship. This warranty extends to the original retail purchaser only and shall continue for a period of 1 year (or 2000 hrs.) whichever occurs first on all components from the date of sale to the first retail purchaser or date of original use, whichever is earlier. Any such parts proving to be thus defective within the warranty period may be, at the option of Manitou, either repaired or replaced. If required by Manitou, defective parts are to be returned to the Manitou factory, and provided further that written notice of such defects shall be given to Manitou at the address shown below within 30 days of discovery of such defects.

The obligation of Manitou to the purchaser under this warranty is limited to the repair or replacement of defective parts, which will be made free of charge for both parts and labor, using Manitou service parts. Repair or replacement in accordance with this warranty shall constitute fulfillment of all liabilities of Manitou and the selling dealer.

Repairs or replacements will be performed by the selling dealer following delivery of the truck by the purchaser to the selling dealer's place of business. If the purchaser has moved a long distance from the selling dealer, any authorized Manitou dealer will perform the repairs at its dealership.

#### WHAT IS NOT COVERED BY THE WARRANTY:

1. Manitou makes no warranty what-so-ever with respect to tires and tubes.
2. Parts not manufactured by Manitou are not covered by this warranty and any warranty on such parts is limited to that extended by the original equipment manufacturer of such parts.
3. This warranty shall not apply:
  - a. If the truck has been subject to misapplication, abuse, misuse, negligence, fire or other accident;
  - b. If parts not made or supplied by Manitou have been used in connection with the truck, if in the sole judgment of Manitou such use affects its performance, stability or reliability;
  - c. If the truck has been altered or repaired outside of a Manitou dealership in a manner which, in the sole judgment of Manitou, affects its performance, stability or reliability;
  - d. To incidental charges such as towing, travel time, delivery charges, hydraulic oil, lubricants, fuel or anti-freeze;
  - e. To normal maintenance services (such as tune-ups, fuel system cleaning and wheel, brake and clutch adjustments), to normal replacement of service items (such as filters, spark plugs, brake or clutch linings), or to normal deterioration due to use or exposure (such as belts and exterior finish);
  - f. Unless all safety devices and guards provided with the equipment are properly installed and used in this operation and unless there is compliance with all operating procedures and maintenance instructions as set forth in the instructional and operating manuals furnished by the Company;
  - g. To any truck if its serial number has been altered, defaced or removed, or if payment for the lift truck is in default.

#### DISCLAIMER OF IMPLIED WARRANTIES & CONSEQUENTIAL DAMAGES:

THERE ARE NO EXPRESSED WARRANTIES COVERING THE LIFT TRUCKS MANUFACTURED BY MANITOU OTHER THAN AS SET FORTH ABOVE, AND THE ABOVE WRITTEN WARRANTY IS IN LIEU OF ANY IMPLIED WARRANTIES, INCLUDING ANY IMPLIED WARRANTY OF MERCHANTABILITY OR FITNESS FOR A PARTICULAR PURPOSE. In no event shall Manitou be liable for special, incidental or consequential damages or claims therefor, including (but not limited to) damages or claims due to lost profits, lost time, transportation, personal injury, property damage or other expenses whether or not resulting directly or indirectly from claimed defects covered by the above written warranty. Neither Manitou nor its authorized dealers shall have any responsibility for loss of use of the lift truck, loss of time, inconvenience, commercial loss or consequential damages. No person is authorized to make on behalf of Manitou any representations beyond those expressed herein.

#### RIGHT TO MAKE DESIGN CHANGES:

Manitou Americas, Inc. reserves the right to make changes in the design and other changes in its products at any time and from time to time without notice and without incurring any obligation with respect to any product previously ordered from it, sold or shipped by it.

This agreement has been prepared in multiple languages, including but not limited to, English, Spanish, and French (Canada). In the event of any inconsistency, the English version shall apply and be binding upon the parties.

All notices, demands, claims or other communications with respect to this written warranty must be addressed to:  
Manitou Americas, Inc., one Gehl way, P.O. Box 179, West Bent WI 53095  
Phone: 262-334-9461 ~ Fax: 262-338-7517

50940456/AP0616



## NEW MAST

### WARRANTY AND LIMITATIONS OF LIABILITY

#### COVERAGE PROVIDED:

Manitou Americas, Inc. (Manitou) warrants every part of the masts manufactured by it to be free under normal use and service from defects in material and workmanship. This warranty extends to the original retail purchaser only and shall continue for a period of six months (or 1200 hours); whichever occurs first, on all components from the date of sale to the first retail purchaser or date of original use, whichever is earlier. Any such parts proving to be thus defective within the warranty period, may be at the option of Manitou, either repaired or replaced, provided that such defective parts are returned freight prepaid to Manitou's factory, and provided further, that written notice of such defects shall be given to Manitou within 10 days of discovery of such defects.

The obligation of Manitou to the purchaser under this warranty is limited to the repair or replacement of defective parts, which will be made free of charge for both parts and labor, using Manitou service parts. Repair or replacement in accordance with this warranty shall constitute fulfillment of all liabilities of Manitou and the selling dealer.

Repairs or replacement will be performed by the selling dealer following delivery of the mast by the purchaser to the selling dealer's place of business. If the purchaser is aware of any of these steps not being taken, they should immediately notify Manitou directly.

The selling dealer shall review these warranty provisions with the purchaser prior to retail sale, secure his acknowledgment of delivery of this warranty, record the date of original retail sale or date of original use, insure the delivery to the purchaser of the instructional and operating manuals furnished by Manitou and mail a signed copy of the warranty to Manitou at West Bend, Wisconsin.

#### WHAT IS NOT COVERED BY THE WARRANTY:

This warranty shall not apply:

1. If the mast has been subject to misapplication, abuse, misuse, negligence, fire or other accident;
2. If parts not made or supplied by Manitou have been used in connection with the mast, if in the sole judgment of Manitou such use affects its performance or reliability;
3. If the mast has been altered or repaired in a manner which, in the sole judgment of Manitou affects its performance or reliability;
4. To incidental charges such as towing, travel time, delivery charges, hydraulic oil, or lubricants;
5. To any mast if its serial number has been altered, defaced or removed, or if payment for the mast is in default.

#### DISCLAIMER OF IMPLIED WARRANTIES & CONSEQUENTIAL DAMAGES:

THERE ARE NO EXPRESSED WARRANTIES COVERING THE MASTS MANUFACTURED BY MANITOU OTHER THAN AS SET FORTH ABOVE, AND THE ABOVE WRITTEN WARRANTY IS IN LIEU OF ANY IMPLIED WARRANTIES, INCLUDING ANY IMPLIED WARRANTY OR MERCHANTABILITY OR FITNESS FOR A PARTICULAR PURPOSE. In no event shall Manitou be liable for special, incidental or consequential damages or claims therefor, including (but not limited to) damages or claims due to lost profits, lost time, transportation, personal injury, property damage or other expenses whether or not resulting directly or indirectly from claimed defects covered by the above written warranty. Neither Manitou nor its authorized dealers shall have any responsibility for loss of use of the mast, loss of time, inconvenience, commercial loss or consequential damages. No person is authorized to make on behalf of Manitou any representations beyond those expressed herein.

#### RIGHT TO MAKE DESIGN CHANGES:

Manitou Americas, Inc. reserves the right to make changes in the design and other changes in its products at any time and from time to time without notice and without incurring any obligation with respect to any product previously ordered from it, sold or shipped by it.

This agreement has been prepared in multiple languages, including but not limited to, English, Spanish, and French (Canada). In the event of any inconsistency, the English version shall apply and be binding upon the parties.

All notices, demands, claims or other communications with respect to this written warranty must be addressed to:  
Manitou Americas, Inc., One Gehl Way, P.O. Box 179, West Bend, WI 53095  
Phone: 262-334-9461 ~ Fax: 262-338-7517

50940459/AP0616



# **2 - DESCRIPTION**



# TABLE OF CONTENTS

## 2 - DESCRIPTION

<b><u>CE DECLARATION OF CONFORMITY</u></b>	<b>5</b>
<b><u>SAFETY PLATES AND STICKERS</u></b>	<b>7</b>
<b><u>IDENTIFICATION OF THE LIFT TRUCK</u></b>	<b>11</b>
<b><u>CHARACTERISTICS</u></b> M 26-2+H ST3B	<b>14</b>
<b><u>CHARACTERISTICS</u></b> M 26-4+H ST3B	<b>17</b>
<b><u>CHARACTERISTICS</u></b> M 30-2+H ST3B	<b>20</b>
<b><u>CHARACTERISTICS</u></b> M 30-4+H ST3B	<b>23</b>
<b><u>CHARACTERISTICS</u></b> M 40-2+H ST3B	<b>26</b>
<b><u>CHARACTERISTICS</u></b> M40-4+H SR3B	<b>29</b>
<b><u>CHARACTERISTICS</u></b> M 50-2+H ST3B	<b>32</b>
<b><u>CHARACTERISTICS</u></b> M 50-4+H ST3B	<b>35</b>
<b><u>CHARACTERISTICS OF MAST WITH ROLLERS</u></b> M26-2+H ST3B M26-4+H ST3B	<b>38</b>
<b><u>CHARACTERISTICS OF MASTS WITH ROLLERS</u></b> M 30-2+H ST3B M 30-4+H ST3B	<b>39</b>
<b><u>CHARACTERISTICS OF MAST WITH ROLLERS</u></b> M40-2+H ST3B M40-4+H ST3B	<b>40</b>
<b><u>CHARACTERISTICS OF MASTS WITH ROLLERS</u></b> M 50-2+H ST3B M 50-4+H ST3B	<b>41</b>
<b><u>TIRES</u></b>	<b>42</b>
<b><u>DIMENSIONS AND LOAD CHARTS</u></b> M 26/30-2+H ST3B	<b>44</b>
<b><u>DIMENSIONS AND LOAD CHARTS</u></b> M 26/30-4+H ST3B	<b>46</b>
<b><u>DIMENSIONS AND LOAD CHARTS</u></b> M 40-2+H ST3B	<b>48</b>
<b><u>DIMENSIONS AND LOAD CHARTS</u></b> M 40-4+H ST3B	<b>50</b>
<b><u>DIMENSIONS AND LOAD CHARTS</u></b> M 50-2+H ST3B	<b>52</b>
<b><u>DIMENSIONS AND LOAD CHARTS</u></b> M 50-4+H ST3B	<b>54</b>



1) **DÉCLARATION «CE» DE CONFORMITÉ (originale)**  
**« EC » DECLARATION OF CONFORMITY (original)**

2) La société, *The company* : **MANITOU BF**

3) Adresse, *Address* : **430, rue de l'Aubinière - BP 10249 - 44158 - ANCENIS CEDEX - FRANCE**

4) Dossier technique, *Technical file* : **MANITOU BF - 430, rue de l'Aubinière  
BP 10249 - 44158 - ANCENIS CEDEX - FRANCE**

5) Constructeur de la machine décrite ci-après, *Manufacturer of the machine described below* :

**M 26/30-2+H ST3B      M 26/30-4+H ST3B**

**M 40/50-2+H ST3B      M 40/50-4+H ST3B**

6) Déclare que cette machine, *Declares that this machine* :

7) Est conforme aux directives suivantes et à leurs transpositions en droit national, *Complies with the following directives and their transpositions into national law* :

**2006/42/CE**

8) Pour les machines annexe IV, *For annex IV machines* :

9) Numéro d'attestation, *Certificate number* :

10) Organisme notifié, *Notified body* :

15) Normes harmonisées utilisées, *Harmonised standards used* :

16) Normes ou dispositions techniques utilisées, *Standards or technical provisions used* :

17) Fait à, *Done at* : **Ancenis**

18) Date, *Date* : **03/07/2012**

19) Nom du signataire, *Name of signatory* : **Éric LAMBERT**

20) Fonction, *Function* : **Président division RTH**

21) Signature, *Signature* :

**bg :** 1) удостоверение за « CE » съответствие (оригинална), 2) Фирмата, 3) Адрес, 4) Техническо досие, 5) Фабрикант на описаната по-долу машина, 6) Обявява, че тази машина, 7) Отговаря на следните директиви и на тяхното съответствие национално право, 8) За машините към допълнение IV, 9)Номер на удостоверението, 10) Наименувана фирма, 15) хармонизирани стандарти използвани, 16) стандарти или технически правила, използвани, 17) Изработено в, 18) Дата, 19) Име на разписалия се, 20) Функция, 21) Функция.

**cs :** 1) **ES prohlášení o shodě (původní)**, 2) Název společnosti, 3) Adresa, 4) Technická dokumentace, 5) Výrobce níže uvedeného stroje, 6) Prohlašuje, že tento stroj, 7) Je v souladu s následujícími směrnici a směrnici transponovanými do vnitrostátního práva, 8) Pro stroje v příloze IV, 9) Číslo certifikátu, 10) Notifikační orgán, 15) harmonizované normy použity, 16) Norem a technických pravidel používaných, 17) Místo vydání, 18) Datum vydání, 19) Jméno podepsaného, 20) Funkce, 21) Podpis.

**da :** 1) **EF Overensstemmelseserklæring (original)**, 2) Firmaet, 3) Adresse, 4) tekniske dossier, 5) Konstruktor af nedenfor beskrevne maskine, 6) Erklærer, at denne maskine, 7) Overholder nedennævnte direktiver og disses gennemførelse til national ret, 8) For maskiner under bilag IV, 9) Certifikat nummer, 10) Bemyndigede organ, 15) harmoniserede standarder, der anvendes, 16) standarder eller tekniske regler, 17) Udfærdiget i, 18) Dato, 19) Underskrivers navn, 20) Funktion, 21) Underskrift.

**de :** 1) **EG-Konformitätserklärung (original)**, 2) Die Firma, 3) Adresse, 4) Technischen Unterlagen, 5) Hersteller der nachfolgend beschriebenen Maschine, 6) Erklärt, dass diese Maschine, 7) den folgenden Richtlinien und deren Umsetzung in die nationale Gesetzgebung entspricht, 8) Für die Maschinen laut Anhang IV, 9) Bescheinigungsnummer, 10) Benannte Stelle, 15) angewandten harmonisierten Normen, 16) angewandten sonstigen technischen Normen und Spezifikationen, 17) Ausgestellt in, 18) Datum, 19) Name des Unterzeichners, 20) Funktion, 21) Unterschrift.

**el :** 1) **Δήλωση συμμόρφωσης CE (πρωτότυπο)**, 2) Η εταιρεία, 3) Διεύθυνση, 4) τεχνικό φάκελο, 5) Κατασκευάστρια του εξής περιγραφόμενου μηχανήματος, 6) Δηλώνει ότι αυτό το μηχάνημα, 7) Είναι σύμφωνο με τις εξής οδηγίες και τις προσαρμογές τους στο εθνικό δίκαιο, 8) Για τα μηχανήματα παραρτήματος IV, 9) Αριθμός δήλωσης, 10) Κοινοποιημένος φορέας, 15) εναρμονισμένα πρότυπα που χρησιμοποιούνται, 16) Πρότυπα ή τεχνικούς κανόνες που χρησιμοποιούνται, 16) Είναι σύμφωνο με τα εξής πρότυπα και τεχνικές διατάξεις, 17) Εν, 18) Ημερομηνία, 19) Όνομα του υπογράφοντος, 20) Θέση, 21) Υπογραφή.

**es :** 1) **Declaración DE de conformidad (original)**, 2) La sociedad, 3) Dirección, 4) expediente técnico, 5) Constructor de la máquina descrita a continuación, 6) Declara que esta máquina, 7) Está conforme a las siguientes directivas y a sus transposiciones en derecho nacional, 8) Para las máquinas anexo IV, 9) Número de certificación, 10) Organismo notificado, 15) normas armonizadas utilizadas, 16) Otras normas o especificaciones técnicas utilizadas, 17) Hecho en, 18) Fecha, 19) Nombre del signatario, 20) Función, 21) Firma.

**et :** 1) **EÜ vastavusdeklaratsioon (algupärane)**, 2) Äriühing, 3) Aadress, 4) Tehniline dokumentatsioon, 5) Seadme tootja, 6) Kinnitab, et see toode, 7) On vastavuses järgmiste direktiivide ja nende riigisisese õigussesse ülevõtmiseks vastuvõetud õigusaktidega, 8) IV lisas loetletud seadmete puhul, 9) Tunnistuse number, 10) Sertifitseerimisasutus, 15) kasutatud ühtlustatud standardite, 16) Muud standardites või spetsifikatsioonides kasutatakse, 17) Väljaandmise koht, 18) Väljaandmise aeg, 19) Allkirjastaja nimi, 20) Amet, 21) Allkiri.

**fi :** 1) **EY-vaatimustenmukaisuusvakuutus (alkuperäiset)**, 2) Yritys, 3) Osoite, 4) teknisen eritelmän, 5) Jäljessä kuvaten koneen valmistaja, 6) Vakuuttaa, että tämä kone, 7) Täyttää seuraavien direktiivien sekä niitä vastaavien kansallisten säännösten vaatimukset, 8) Liitteen IV koneiden osalta, 9) Todistuksen numero, 10) Ilmoitettu laitos, 15) yhdenmukaistettuja standardeja käytetään, 16) muita standardeja tai eritelmät, 17) Paikka, 18) Aika, 19) Allekirjoittajan nimi, 20) Toimi, 21) Allekirjoitus.

**ga :** 1) **« EC » dearbhú comhréachta (bunaidh)**, 2) An comhlacht, 3) Seoladh, 4) comhad teicniúil, 5) Déantóir an innill a thuairiscítear thíos, 6) Dearbhaíonn sé go bhfuil an t-inneall, 7) Go gclóinn sé le na teoracha seo a leanas agus a trasúimh isteach i ndlí náisiúnta, 8) Le haghaidh innill an agusín IV, 9) Uimhir teastais, 10) Comhlacht a chuireadh i bhfíos, 15) caighdeán comhchuibhithe a úsáidtear, 16) caighdeán eile nó sonraíochtaí teicniúla a úsáidtear, 17) Déanta ag, 18) Dáta, 19) Ainm an tsínitheora, 20) Feidhm, 21) Síniú.

**hu :** 1) **CE megfelelőségi nyilatkozat (eredeti)**, 2) A vállalat, 3) Cím, 4) műszaki dokumentáció, 5) Az alábbi gép gyártója, 6) Kijelenti, hogy a gép, 7) Megfelel az alábbi irányelveknek valamint azok módosított előírásainak, 8) A IV. melléklet gépeihez, 9) Bizonylati szám, 10) Ertesített szervezet, 15) felhasznált harmonizált szabványok, 16) egyéb felhasznált műszaki szabványok és előírások hivatkozásai, 17) Kelt (hely), 18) Dátum, 19) Aláíró neve, 20) Funkció, 21) Aláírás.

**is :** 1) **(Samræmisvottorð ESB (upprunalega)**, 2) Fyrirtækið, 3) Aðsetur, 4) Tæknilegar skrá, 5) Smíður tækisins sem lýst er hér á eftir, 6) Staðfestir að tækið, 7) Samræmist eftirfarandi stöðlum og staðærslu þeirra með hlífðsjón af þjóðarrétti, 8) Fyrir tækin í aukakafla IV, 9) Staðfestingarnúmer, 10) Tilkynnt til, 15) samhæfða staðla sem notaðir, 16) önnur staðlar eða forskriftir notað, 17) Staður, 18) Dagsetning, 19) Nafn undirritaða, 20) Staða, 21) Undirskrift.

**it :** 1) **Dichiarazione CE di conformità (originale)**, 2) La società, 3) Indirizzo, 4) fascicolo tecnico, 5) Costruttore della macchina descritta di seguito, 6) Dichiaro che questa macchina, 7) È conforme alle direttive seguenti e alle relative trasposizioni nel diritto nazionale, 8) Per le macchine Allegato IV, 9) Numero di Attestazione, 10) Organismo notificato, 15) norme armonizzate applicate, 16) altre norme e specifiche tecniche applicate, 17) Stabilita a, 18) Data, 19) Nome del firmatario, 20) Funzione, 21) Firma.

**lt :** 1) **CE atitikties deklaracija (originalas)**, 2) Bendrovė, 3) Adresas, 4) Techninė byla, 5) Žemiau nurodytas įrenginio gamintojas, 6) Pareiškia, kad šis įrenginys, 7) Atitinka toliau nurodytas direktyvas ir į nacionalinius teisės aktus perkeltas jų nuostatas, 8) IV priedas dėl mašinų, 9) Sertifikačio Nr, 10) Paskelbtoji įstaiga, 15) suderintus standartus naudojamus, 16) Kiti standartai ir techninės specifikacijos, 17) Pasirašytas, 18) Data, 19) Pasirašiusio asmens vardas ir pavardė, 20) Pareigos, 21) Parašas.

**lv :** 1) **EK atbilstības deklarācija (oriģināls)**, 2) Uzņēmums, 3) Adrese, 4) tehniskās lietas, 5) Tālāk aprakstītās iekārtas ražotājs, 6) Apliecinā, ka šī iekārta, 7) Ir atbilstoša tālāk norādītajām direktīvām un to transpozīcijai nacionālajā likumdošanā, 8) Iekārtām IV pielikumā, 9) Apliecināš numurs, 10) Reģistrētā organizācija, 15) lietotajiem saskaņotajiem standartiem, 16) lietotajiem tehniskajiem standartiem un specifikācijām, 17) Sastādīts, 18) Datums, 19) Parakstītāja vārds, 20) Amats, 21) Paraksts.

**mt :** 1) **Dikjarazzjoni ta' Konformità KE (originali)**, 2) Il-kumpanija, 3) Indirizz, 4) fajl tekniku, 5) Manifattriċi tal-magna deskritta hawn isfel, 6) Tiddikjara li din il-magna, 7) Hija konformi hija konformi mad-Direttivi segwenti u l-Igijiet li jimplementawhom fil-ligi nazzjonali, 8) Għall-magni fl-Anness IV, 9) Numru taċ-certifikat, 10) Entità nnotifikata, 15) l-Istandards armonizzati użati, 16) standards tekniċi u specifikazzjonijiet oħra użati, 17) Magħmul f', 18) Data, 19) Isem il-firmatarju, 20) Kariga, 21) Firma.

**nl :** 1) **EG-verklaring van overeenstemming (oorspronkelijke)**, 2) Het bedrijf, 3) Adres, 4) technisch dossier, 5) Constructeur van de hierna genoemde machine, 6) Verklaart dat deze machine, 7) In overeenstemming is met de volgende richtlijnen en hun omzettingen in het nationale recht, 8) Voor machines van bijlage IV, 9) Goedkeuringsnummer, 10) Aangezegde instelling, 15) gehanteerde geharmoniseerde normen, 16) andere gehanteerde technische normen en specificaties, 17) Opgemaakt te, 18) Datum, 19) Naam van ondergetekende, 20) Functie, 21) Handtekening.

**no :** 1) **CE-samsvarserklæring (original)**, 2) Selskapet, 3) Adresse, 4) tekniske arkiv, 5) Fabrikant av følgende maskin, 6) Erklærer at denne maskinen, 7) Oppfyller kravene i følgende direktiver, med nasjonale gjennomføringsbestemmelser, 8) For maskinene i tillegg IV, 9) Attestnummer, 10) Notifisert organ, 15) harmoniserte standarder som brukes, 16) Andre standarder og spesifikasjoner brukt, 17) Utstedt i, 18) Dato, 19) Underskriverens navn, 20) Stilling, 21) Underskrift.

**pl :** 1) **Deklaracja zgodności CE (oryginalne)**, 2) Spółka, 3) Adres, 4) dokumentacja technicznej, 5) Wykonawca maszyny opisanej poniżej, 6) Oświadcza, że ta maszyna, 7) Jest zgodna z następującymi dyrektywami i odpowiadającymi przepisami prawa krajowego, 8) Dla maszyn załącznik IV, 9) Numer certyfikatu, 10) Jednostka certyfikująca, 15) zastosowanych norm zharmonizowanych, 16) innych zastosowanych norm technicznych i specyfikacji, 17) Sporządzono w, 18) Data, 19) Nazwisko podpisującego, 20) Stanowisko, 21) Podpis.

**pt :** 1) **Declaração de conformidade CE (original)**, 2) A empresa, 3) Morada, 4) processo técnico, 5) Fabricante da máquina descrita abaixo, 6) Declara que esta máquina, 7) Está em conformidade às directivas seguintes e às suas transposições para o direito nacional, 8) Para as máquinas no anexo IV, 9) Número de certificado, 10) Entidade notificada, 15) normas harmonizadas utilizadas, 16) outras normas e especificações técnicas utilizadas, 17) Elaborado em, 18) Data, 19) Nome do signatário, 20) Cargo, 21) Assinatura.

**ro :** 1) **Declarație de conformitate CE (originală)**, 2) Societatea, 3) Adresa, 4) cartii tehnice, 5) Constructor al mașinii descrise mai jos, 6) Declară că prezenta mașină, 7) Este conformă cu directivele următoare și cu transpunerea lor în dreptul național, 8) Pentru mașinile din anexa IV, 9) Număr de atestare, 10) Organism notificat, 15) standardele armonizate utilizate, 16) alte standarde și specificații tehnice utilizate, 17) Întocmit la, 18) Data, 19) Numele persoanei care semnează, 20) Funcția, 21) Semnătură.

**sk :** 1) **ES vyhlásenie o zhode (pôvodný)**, 2) Názov spoločnosti, 3) Adresa, 4) technickej dokumentácie, 5) Výrobca nižšie opísaného stroja, 6) Vyhlasuje, že tento stroj, 7) Je v súlade s nasledujúcimi smernicami a smernicami transponovanými do vnútroštátneho práva, 8) Pre stroje v prílohe IV, 9) Číslo certifikátu, 10) Notifikačný orgán, 15) použité harmonizované normy, 16) použité iné technické normy a predpisy, 17) Miesto vydania, 18) Dátum vydania, 19) Meno podpisujúceho, 20) Funkcia, 21) Podpis.

**sl :** 1) **ES Izjava o ustreznosti (izvirna)**, 2) Družba, 3) Naslov, 4) tehnične dokumentacije, 5) Proizvajalac tukaj opisanega stroja, 6) Izjavlja, da je ta stroj, 7) Ustreza naslednjim direktivam in njihovi transpoziciji v državno pravo, 8) Za stroje priloga IV, 9) Številka potrdila, 10) Obvestilo organu, 15) uporabljene harmonizirane standarde, 16) druge uporabljene tehnične standarde in zahteve, 17) V, 18) Datum, 19) Ime podpisnika, 20) Funkcija, 21) Podpis.

**sv :** 1) **CE-försäkran om överensstämmelse (original)**, 2) Företaget, 3) Adress, 4) tekniska dokumentationen, 5) Konstruktor av nedan beskrivna maskin, 6) Försäkrar att denna maskin, 7) Överensstämmer med nedanstående direktiv och införlivandet av dem i nationell rätt, 8) För maskinerna i bilaga IV, 9) Nummer för godkännande, 10) Organism som underrättats, 15) Harmoniserade standarder som använts, 16) andra tekniska standarder och specifikationer som använts, 17) Upprättat i, 18) Datum, 19) Namn på den som undertecknat, 20) Befattning, 21) Namnteckning.

# SAFETY PLATES AND STICKERS

## ⚠ IMPORTANT ⚠

Clean all of the stickers and safety plates to make them legible.  
It is essential to replace stickers and safety plates which are illegible or damaged.  
Check the presence of stickers and safety plates after replacing any spare parts.

### EXTERNAL PLATES AND STICKERS

REF	PART NUMBER	DESCRIPTION
①	288174	- Accumulator Instructions
②	24653	- Slings point
③	296751	- Diesel fuel
④	234798	- Hydraulic oil
⑤	296733	- Battery cut-off instruction

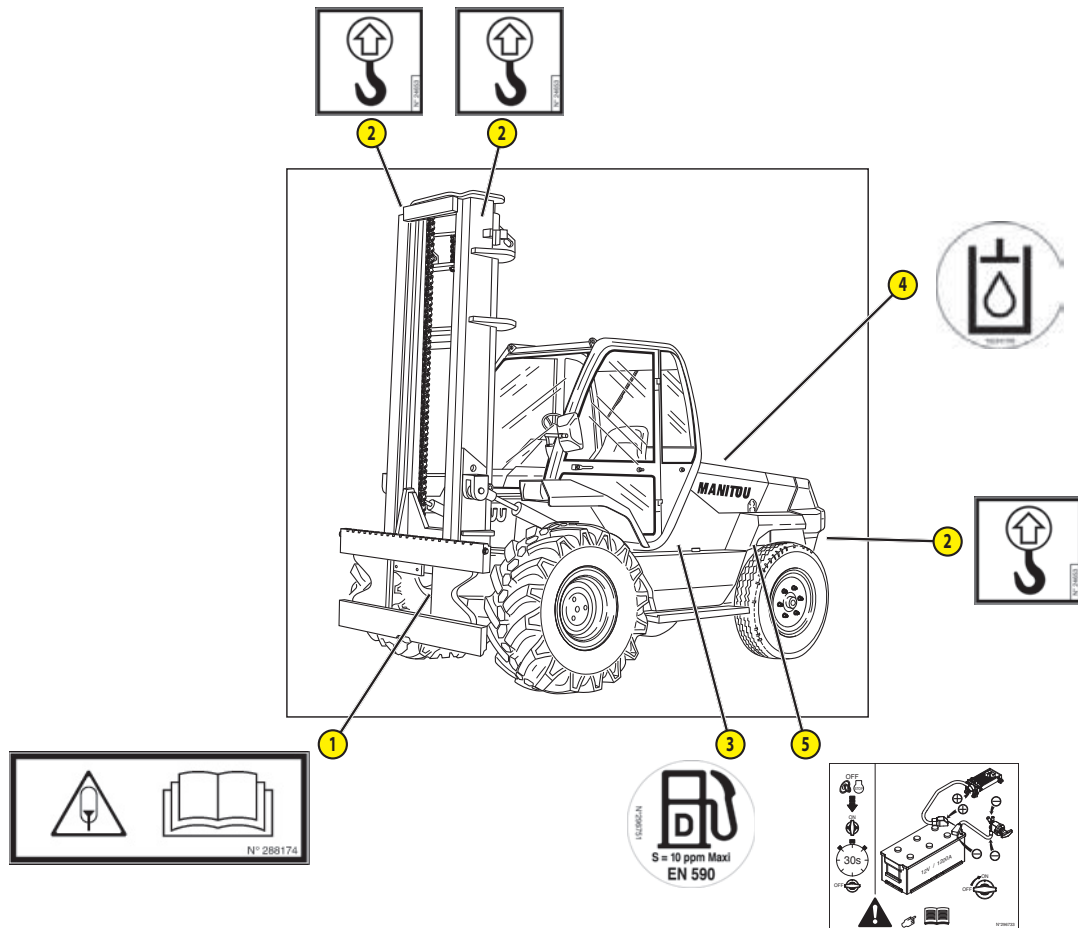

## STICKERS AND PLATES UNDER THE ENGINE HOOD

REF	PART NUMBER	DESCRIPTION
①	293887	- Anti-freeze
②	259398	- Water / diesel separator
③	716906	- Fan hazard

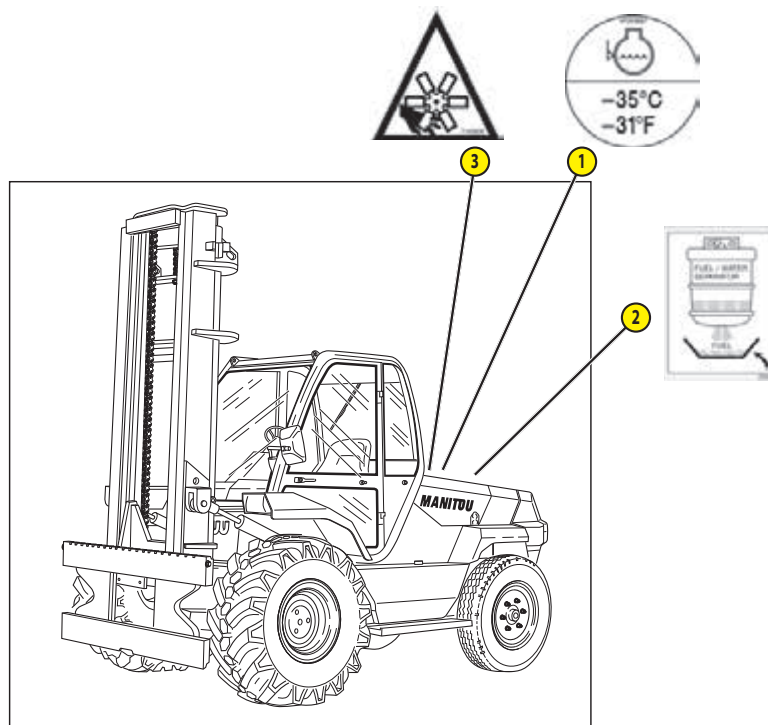

**STICKERS AND PLATES IN THE CAB**

REF	PART NUMBER	DESCRIPTION
1	300681	- Safety instructions
2	234806	- Locking Safety Instructions
3	239595	- Sound power level 105dB
4	Consult your dealer	- Manufacturer's plate
5	33460	- Gear lever control
6	200042	- Manipulator function
7	203792	- Manipulator function
8	203791	- Manipulator function
9	203928	- Manipulator function
10	203929	- Manipulator function
11	268491	- Brake fluid instruction
12	76571	- Forward/ reverse lever
13	Consult your dealer	- Load chart (depending on the model)
14	Consult your dealer	- Load chart (depending on the model)
15	304478	- Greasing instructions
16	309444	- Fuse

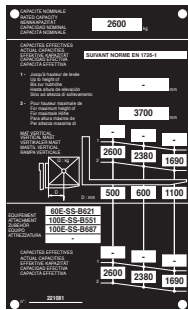

13

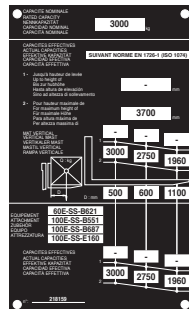

13

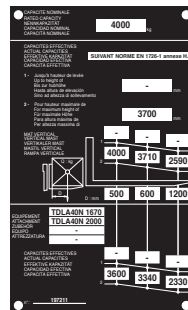

14

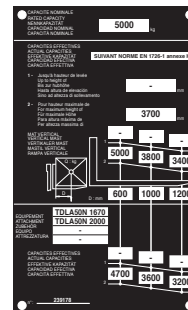

14

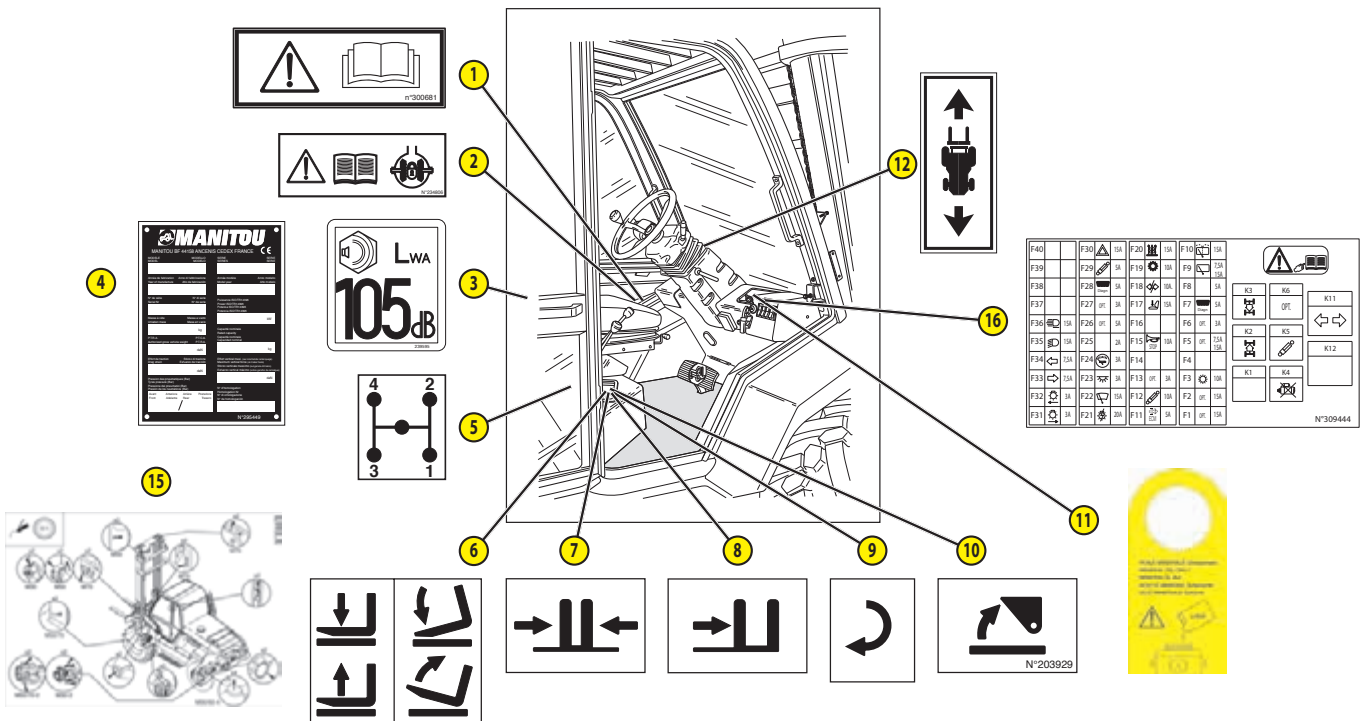



## IDENTIFICATION OF THE LIFT TRUCK

As our policy is to promote a constant improvement of our products, our range of telescopic lift trucks may undergo certain modifications, without obligation for us to advise our customers.

When you order parts, or when you require any technical information, always specify:

NOTE: For the owner's convenience, it is recommended that a note of these numbers is made in the spaces provided, at the time of the delivery of the lift truck.

### LIFT TRUCK MANUFACTURER'S PLATE

- 1 - MODEL
- 2 - SERIES
- 3 - Year of manufacture
- 4 - Model year
- 5 - Serial No.
- 6 - Power ISO/TR 14396
- 7 - Unladen mass
- 8 - Authorised gross vehicle weight
- 9 - Rated capacity
- 10 - Drag strain
- 11 - Maximum vertical force (on trailer hook)
- 12 - Tyre pressure (bar)
- 13 - Homologation No.

MANITOU			
MANITOU BF 44188 ANCENIS CEDEX FRANCE			
MODELLO	SERIE	ANNO	CE
MODEL	SERIES	YEAR	CE
1	2	3	4
5	6	7	8
9	10	11	12
13			

For any further technical information regarding your lift truck refer to chapter: 2 - DESCRIPTION: CHARACTERISTICS.

### I.C. ENGINE

- I.C. engine No.



### GEAR BOX 4-SPEED MODELS ONLY

- Type
- MANITOU reference
- Serial No.



### HYDROSTATIC TRANSMISSION MODELS ONLY

- Type
- MANITOU reference
- Serial No.

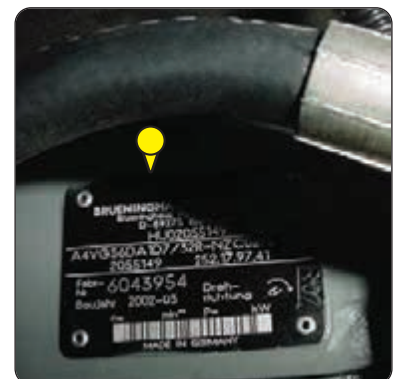

647122 (28/10/2024)  
M26/30-2 + H ST3B / M26/30-4 + H ST3B  
M40/50-2 + H ST3B / M40/50-4 + H ST3B

## HYDROSTATIC MOTOR, HYDROSTATIC MODELS ONLY

- Type
- MANITOU reference
- Serial No.



## GEAR BOX (2 SPEED, HYDROSTATIC MODELS ONLY)

- Type
- MANITOU reference
- Serial No.



## FRONT AXLE

- Type
- Serial No.
- MANITOU reference

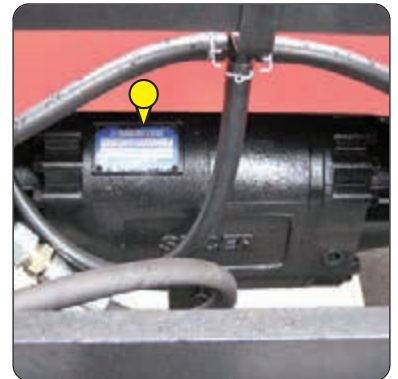

## REAR AXLE

M 26/30-4+H ST3B      M 40/50-4+H ST3B

- Type
- Serial No.
- MANITOU reference

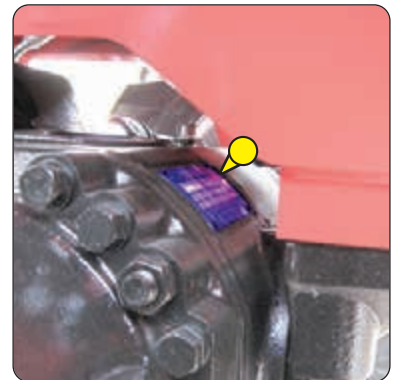

## OVERHEAD GUARD

- Type
- Serial No.



647122 (28/10/2024)  
M26/30-2 + H ST3B / M26/30-4 + H ST3B  
M40/50-2 + H ST3B / M40/50-4 + H ST3B

## **MASTS WITH ROLLERS**

- Mast identification No.



## **MANUFACTURER'S PLATE**

- Model
- Serial no.
- Year of manufacture



## **CHASSIS**

- Lift truck serial No.

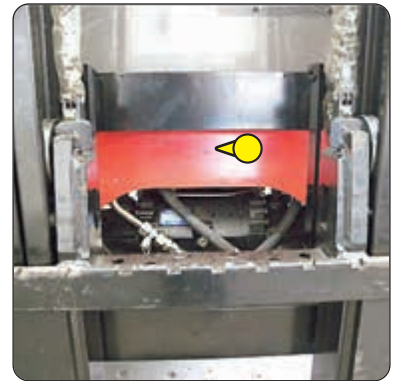

<b>I.C. ENGINE</b>		
Type		PERKINS 854F-E34T 54009,1,1
Fuel		Diesel
Number of cylinders		4 in line
Suction		Supercharged
Injection system		Direct
Ignition sequence		1.3.4.2
Capacity	cm3	3400
Bore and stroke	mm	99 x 110
Compression ratio		17:1
Nominal rating loaded	rpm	2200
Rating slow unladen	rpm	850
Max. rating unladen	rpm	3125
Power ISO/TR 14396	hp- kW	75 - 55,5
Power SAE J 1995	hp- kW	75 - 55,5
Maximum torque ISO/TR 14396	Nm	318 to 1400 rpm
Air cleaner	µm	3
Type of cooling		By water
Fan		Puller

<b>TRANSMISSION 4 SPEED</b>		
Gear box		TURNER POWERTRAIN SYSTEMS
- Type		Mechanical
- Forward/reverse selector		Electro-hydraulic
- Torque converter		SACHS
- Number of forward speeds		4
- Number of reverse speeds		4
Front axle		DANA
- Differential		With locking
Rear axle		MANITOU
- Differential		Without locking
Drive wheels		2WD Permanent
- Switch for 2/4 drive wheels		No
Front tyres		CONTINENTAL
- Size		14,5R20 18PR MPT80 TL
- Pressure	bar	3,5
Rear tyres		GOODYEAR
- Size		10R17,5 134/132M G291
- Pressure	bar	5,5

<b>HYDROSTATIC TRANSMISSION</b>		
Hydrostatic Pump		REXROTH
- Type		A4VG56DA
- Gear Reverser		ELECTROHYDRAULIC
- Inching Control		HYDRAULIC VALVE TH7
- Number of forward gears		1
- Number of reverse gears		1
Main Pump		
• Min. Max Displacement		0-71 cm3 (3.42 cu in)
• Minimum Capacity		0 cm3/t
• Max. Flow Rate		210 L/min (55.47 gal/min)
• Working pressure		7251 psi
Boost Pump		
• Displacement		19.6 cm3/t
• Max. Flow Rate		58 l/mn
• Boost Pressure MAX. RPM		30 bar, Transmission au neutre
Hydrostatic Motor		REXROTH (Variable Displacement)
- Type		A6VM107DA1/63W
- Min. - Max. displacement	cm3/t	28-28

<b>ELECTRIC CIRCUIT</b>		
Battery	STANDARD	12 V - 110 Ah - 900 A EN
	OPTION	12 V - 180 Ah - 900 A EN
Alternator		12 V - 100 A
- Type		ISKRA AAK-EF12V
Starter		12 V - 3,2 kW
- Type		ISKRA AZE

<b>BRAKE CIRCUIT</b>		
Service brake		Non-servo hydraulic brake
- Type of brake		Multidisc brake immersed in oil
- Type of control		By foot on front wheels
Parking brake		Mechanical
- Type of brake		Multidisc brake immersed in oil
- Type of control		Manual

<b>HYDRAULIC MOVEMENTS</b>		
Lifting movements		
- Unladen lifting	m/s	0,5
- Laden lifting	m/s	0,5
- Unladen lowering	m/s	0,5
- Laden lowering	m/s	0,5

<b>SOUND AND VIBRATION</b>		
Sound pressure level in the driver's cab LpA (according to standard NF EN 12053)	dB	76
Sound pressure level ensured in the LwA environment (according to directive 2000/14/EC modified by directive 2005/88/EC)	dB	104 (measured) 105 (ensured)
Average weighted acceleration on driver's body (according to standard NF EN 13059)	m/s <sup>2</sup>	.97
The average weighted acceleration transmitted to the driver's hand/arm system (according to standard ISO 5349-2)	m/s <sup>2</sup>	< 2,5

<b>SPECIFICATIONS AND WEIGHTS</b>		
Speed of movement for lift truck in standard configuration on flat ground (except particular conditions)		
Forward unladen	1 km/h	3,4
	2 km/h	6,5
	3 km/h	12,6
	4 km/h	22,1
Rear unladen	1 km/h	3,4
	2 km/h	6,5
	3 km/h	12,6
	4 km/h	22,1
Hydrostatic (Loaded Unloaded Approx.)		
- Low gear	km/h	8
- High Gear	km/h	24
		* Hydrostatic (not yet determined)
Standard mast		DVT 3M70
- Lift height	mm	3700
- Free lift height	mm	130
- Overall height (retracted)	mm	2715
- Overall height (extended)	mm	4745
Carriage		
- Class		FEM3
- width	mm	1470
- Mass of forks (each one)	kg	73
Rated load capacity	kg	2600
Rated load capacity with standard mast	kg	2600
Effective load capacity on forks with side-shift carriage	kg	2600
Distance from the centre of gravity of the load to the base of the forks	mm	500
Lift truck mass without forks or mast	kg	4281
Lift truck mass with standard mast		
- Unladen	kg	5290
- At rated load	kg	8290
Axle mass with standard mast (transport position)		
- Front unladen	kg	2090
- Rear unladen	kg	3200
- Front rated load	kg	6890
- Rear rated load	kg	1400
Drag strain on the coupling hook		
- Unladen (sliding)	daN	1334
- At rated load (transmission setting)	daN	4670
Pull strain with open carrier (according to standard ISO 8313)	daN	

<b>HYDRAULIC CIRCUIT</b>			
Hydraulic pump		PARKER	
- Type		Gear	
		1st casing	2nd casing
- Capacity	cm <sup>3</sup>	31	14
- Max. rating capacity unladen	l/min	97	44
- Flow rate at 1800 rpm	l/min		
Filtration			
- Return	µm	10	
- Suction	µm	125	
Maximum service pressure			
- Double mast with all-round vision	bar	245	
- Triple mast with free-acting lift	bar	260	
- Double mast with free-acting lift	bar	185	
- Triple mast without free-acting lift	bar	260	
- Front/rear tilting circuit	bar	185/185	
- Attachment circuit	bar	185	
- Steering circuit	bar	145	
- Hydraulic shock absorber			
- Capacity	L	0,7	
- Pressure	bar	100	

<b>I.C. ENGINE</b>		
Type		PERKINS 854F-E34T 54009,1,1
Fuel		Diesel
Number of cylinders		4 in line
Suction		Supercharged
Injection system		Direct
Ignition sequence		1.3.4.2
Capacity	cm3	3400
Bore and stroke	mm	99 x 110
Compression ratio		17:1
Nominal rating loaded	rpm	2200
Rating slow unladen	rpm	850
Max. rating unladen	rpm	3125
Power ISO/TR 14396	hp- kW	75 - 55,5
Power SAE J 1995	hp- kW	75 - 55,5
Maximum torque ISO/TR 14396	Nm	318 to 1400 rpm
Air cleaner	µm	3
Type of cooling		By water
Fan		Puller

<b>TRANSMISSION</b>		
Gear box		TURNER POWERTRAIN SYSTEMS
- Type		Mechanical
- Forward/reverse selector		Electro-hydraulic
- Torque converter		SACHS
- Number of forward speeds		4
- Number of reverse speeds		4
Front axle		DANA
- Differential		Without locking
Rear axle		DANA
- Differential		Without locking
Drive wheels		4RWD
- Switch for 2/4 drive wheels		Yes
Front tyres		DUNLOP
- Size		400/70-20 150B T37 STAB TL
- Pressure	bar	2,3
Rear tyres		DUNLOP
- Size		10,5/80-18 10PR TG42 TL
- Pressure	bar	3,5

<b>HYDROSTATIC TRANSMISSION</b>		
Hydrostatic Pump		REXROTH
- Type		A4VG56DA
- Gear Reverser		ELECTROHYDRAULIC
- Inching Control		HYDRAULIC VALVE TH7
- Number of forward gears		2
- Number of reverse gears		2
Main Pump		
• Min. Max Displacement		0-56 cm3 (3.42 cu in)
• Minimum Capacity		0 cm3/t
• Max. Flow Rate		210 L/min (55.47 gal/min)
• Working pressure		7251 psi
Boost Pump		
• Displacement		19.6 cm3/t
• Max. Flow Rate		58 l/mn
• Boost Pressure MAX. RPM		30 bar, Transmission au neutre
Hydrostatic Motor		REXROTH (Variable Displacement)
- Type		A6VM107DA1/63W
- Min. - Max. displacement	cm3/t	32-107

<b>ELECTRIC CIRCUIT</b>		
Battery	STANDARD	12 V - 110 Ah - 900 A EN
	OPTION	12 V - 180 Ah - 900 A EN
Alternator		12 V - 100 A
- Type		ISKRA AAK-EF12V
Starter		12 V - 3,2 kW
- Type		ISKRA AZE

<b>BRAKE CIRCUIT</b>		
Service brake		Non-servo hydraulic brake
- Type of brake		Multidisc brake immersed in oil
- Type of control		By foot on front wheels
Parking brake		Mechanical
- Type of brake		Multidisc brake immersed in oil
- Type of control		Manual

<b>HYDRAULIC MOVEMENTS</b>		
Lifting movements		
- Unladen lifting	m/s	0,5
- Laden lifting	m/s	0,5
- Unladen lowering	m/s	0,5
- Laden lowering	m/s	0,5

<b>SOUND AND VIBRATION</b>		
Sound pressure level in the driver's cab LpA (according to standard NF EN 12053)	dB	76
Sound pressure level ensured in the LwA environment (according to directive 2000/14/EC modified by directive 2005/88/EC)	dB	104 (measured) 104 (ensured)
Average weighted acceleration on driver's body (according to standard NF EN 13059)	m/s <sup>2</sup>	.97
The average weighted acceleration transmitted to the driver's hand/arm system (according to standard ISO 5349-2)	m/s <sup>2</sup>	< 2,5

<b>SPECIFICATIONS AND WEIGHTS</b>		
Speed of movement for lift truck in standard configuration on flat ground (except particular conditions)		
Forward unladen	1	km/h
	2	km/h
	3	km/h
	4	km/h
Rear unladen	1	km/h
	2	km/h
	3	km/h
	4	km/h
Hydrostatic (Loaded Unloaded Approx.)		
- Low gear	km/h	8
- High Gear	km/h	24
		<b>* Hydrostatic (not yet determined)</b>
Standard mast		DVT 3M70
- Lift height	mm	3700
- Free lift height	mm	130
- Overall height (retracted)	mm	2705
- Overall height (extended)	mm	4735
Carriage		
- Class		FEM3
- width	mm	1470
- Mass of forks (each one)	kg	73
Rated load capacity	kg	2600
Rated load capacity with standard mast	kg	2600
Effective load capacity on forks with side-shift carriage	kg	2600
Distance from the centre of gravity of the load to the base of the forks	mm	500
Lift truck mass without forks or mast	kg	4476
Lift truck mass with standard mast		
- Unladen	kg	5485
- At rated load	kg	8485
Axle mass with standard mast (transport position)		
- Front unladen	kg	2155
- Rear unladen	kg	3330
- Front rated load	kg	7000
- Rear rated load	kg	1485
Drag strain on the coupling hook		
- Unladen (sliding)	daN	4250
- At rated load (transmission setting)	daN	6290
Pull strain with open carrier (according to standard ISO 8313)	daN	

HYDRAULIC CIRCUIT			
Hydraulic pump		PARKER	
- Type		Gear	
		1st casing	2nd casing
- Capacity	cm <sup>3</sup>	31	14
- Max. rating capacity unladen	l/min	97	44
- Flow rate at 1800 rpm	l/min		
Filtration			
- Return	µm	10	
- Suction	µm	125	
Maximum service pressure			
- Double mast with all-round vision	bar	245	
- Triple mast with free-acting lift	bar	260	
- Double mast with free-acting lift	bar	185	
- Triple mast without free-acting lift	bar	260	
- Front/rear tilting circuit	bar	185/185	
- Attachment circuit	bar	185	
- Steering circuit	bar	145	
- Hydraulic shock absorber			
- Capacity	L	0,7	
- Pressure	bar	100	

# CHARACTERISTICS M 30-2+H ST3B

I.C. ENGINE		
Type		PERKINS 854F-E34T 54009,1,1
Fuel		Diesel
Number of cylinders		4 in line
Suction		Supercharged
Injection system		Direct
Ignition sequence		1.3.4.2
Capacity	cm <sup>3</sup>	3400
Bore and stroke	mm	99 x 110
Compression ratio		17:1
Nominal rating loaded	rpm	2200
Rating slow unladen	rpm	850
Max. rating unladen	rpm	3125
Power ISO/TR 14396	hp- kW	75 - 55,5
Power SAE J 1995	hp- kW	75 - 55,5
Maximum torque ISO/TR 14396	Nm	318 to 1400 rpm
Air cleaner	µm	3
Type of cooling		By water
Fan		Puller
TRANSMISSION		
Gear box		TURNER POWERTRAIN SYSTEMS
- Type		Mechanical
- Forward/reverse selector		Electro-hydraulic
- Torque converter		SACHS
- Number of forward speeds		4
- Number of reverse speeds		4
Front axle		DANA
- Differential		Without locking
Rear axle		MANITOU
- Differential		With locking
Drive wheels		2RM Permanent
- Switch for 2/4 drive wheels		No
Front tyres		CONTINENTAL
- Size		14,5R20 18PR MPT80 TL
- Pressure	bar	3,5
Rear tyres		GOODYEAR
- Size		10R17,5 134/132M G291
- Pressure	bar	5,5
HYDROSTATIC TRANSMISSION		
Hydrostatic Pump		REXROTH
- Type		A4VG56DA
- Gear Reverser		ELECTROHYDRAULIC
- Inching Control		HYDRAULIC VALVE TH7
- Number of forward gears		1
- Number of reverse gears		1
Main Pump		
• Min. Max Displacement		0-71 cm <sup>3</sup> (3.42 cu in)
• Minimum Capacity		0 cm <sup>3</sup> /t
• Max. Flow Rate		210 L/min (55.47 gal/min)
• Working pressure		7251 psi
Boost Pump		
• Displacement		19.6 cm <sup>3</sup> /t
• Max. Flow Rate		58 l/mn
• Boost Pressure MAX. RPM		30 bar, Transmission au neutre
Hydrostatic Motor		REXROTH (Variable Displacement)
- Type		A6VM107DA1/63W
- Min. - Max. displacement	cm <sup>3</sup> /t	28-28
ELECTRIC CIRCUIT		
Battery	STANDARD	12 V - 110 Ah - 900 A EN
	OPTION	12 V - 180 Ah - 900 A EN
Alternator		12 V - 100 A
- Type		ISKRA AAK-EF12V
Starter		12 V - 3,2 kW
- Type		ISKRA AZE

<b>BRAKE CIRCUIT</b>		
Service brake		Non-servo hydraulic brake
- Type of brake		Multidisc brake immersed in oil
- Type of control		By foot on front wheels
Parking brake		Mechanical
- Type of brake		Multidisc brake immersed in oil
- Type of control		Manual

<b>HYDRAULIC MOVEMENTS</b>		
Lifting movements		
- Unladen lifting	m/s	0,5
- Laden lifting	m/s	0,5
- Unladen lowering	m/s	0,5
- Laden lowering	m/s	0,5

<b>SOUND AND VIBRATION</b>		
Sound pressure level in the driver's cab LpA (according to standard NF EN 12053)	dB	76
Sound pressure level ensured in the LwA environment (according to directive 2000/14/EC modified by directive 2005/88/EC)	dB	104 (measured) 105 (ensured)
Average weighted acceleration on driver's body (according to standard NF EN 13059)	m/s <sup>2</sup>	1
The average weighted acceleration transmitted to the driver's hand/arm system (according to standard ISO 5349-2)	m/s <sup>2</sup>	< 2,5

<b>SPECIFICATIONS AND WEIGHTS</b>		
Speed of movement for lift truck in standard configuration on flat ground (except particular conditions)		
Forward unladen	1 km/h	3,4
	2 km/h	6,5
	3 km/h	12,6
	4 km/h	22,1
Rear unladen	1 km/h	3,4
	2 km/h	6,5
	3 km/h	12,6
	4 km/h	22,1
Hydrostatic (Loaded Unloaded Approx.)		
- Low Gear	km/h	8
- High Gear	km/h	24
		* Hydrostatic (not yet determined)
Standard mast		DVT 3M70
- Lift height	mm	3700
- Free lift height	mm	130
- Overall height (retracted)	mm	2715
- Overall height (extended)	mm	4745
Carriage		
- Class		FEM3
- width	mm	1470
- Mass of forks (each one)	kg	73
Rated load capacity	kg	3000
Rated load capacity with standard mast	kg	3000
Effective load capacity on forks with side-shift carriage	kg	3000
Distance from the centre of gravity of the load to the base of the forks	mm	500
Lift truck mass without forks or mast	kg	4281
Lift truck mass with standard mast		
- Unladen	kg	5290
- At rated load	kg	8290
Axle mass with standard mast (transport position)		
- Front unladen	kg	2090
- Rear unladen	kg	3200
- Front rated load	kg	6890
- Rear rated load	kg	1400
Drag strain on the coupling hook		
- Unladen (sliding)	daN	1334
- At rated load (transmission setting)	daN	4670
Pull strain with open carrier (according to standard ISO 8313)	daN	

HYDRAULIC CIRCUIT			
Hydraulic pump		PARKER	
- Type		Gear	
		1st casing	2nd casing
- Capacity	cm <sup>3</sup>	31	14
- Max. rating capacity unladen	l/min	97	44
- Flow rate at 1800 rpm	l/min		
Filtration			
- Return	µm	10	
- Suction	µm	125	
Maximum service pressure			
- Double mast with all-round vision	bar	245	
- Triple mast with free-acting lift	bar	260	
- Double mast with free-acting lift	bar	185	
- Triple mast without free-acting lift	bar	260	
- Front/rear tilting circuit	bar	185/185	
- Attachment circuit	bar	185	
- Steering circuit	bar	145	
- Hydraulic shock absorber			
- Capacity	L	0,7	
- Pressure	bar	100	

<b>I.C. ENGINE</b>		
Type		PERKINS 854F-E34T 54009,1,1
Fuel		Diesel
Number of cylinders		4 in line
Suction		Supercharged
Injection system		Direct
Ignition sequence		1.3.4.2
Capacity	cm3	3400
Bore and stroke	mm	99 x 110
Compression ratio		17:1
Nominal rating loaded	rpm	2200
Rating slow unladen	rpm	850
Max. rating unladen	rpm	3125
Power ISO/TR 14396	hp- kW	75 - 55,5
Power SAE J 1995	hp- kW	75 - 55,5
Maximum torque ISO/TR 14396	Nm	318 to 1400 rpm
Air cleaner	µm	3
Type of cooling		By water
Fan		Puller

<b>TRANSMISSION</b>		
Gear box		TURNER POWERTRAIN SYSTEMS
- Type		Mechanical
- Forward/reverse selector		Electro-hydraulic
- Torque converter		SACHS
- Number of forward speeds		4
- Number of reverse speeds		4
Front axle		DANA
- Differential		With locking
Rear axle		DANA
- Differential		Without locking
Drive wheels		4RM
- Switch for 2/4 drive wheels		Yes
Front tyres		DUNLOP
- Size		400/70-20 150B T37 STAB TL
- Pressure	bar	2,3
Rear tyres		DUNLOP
- Size		10,5/80-18 10PR TG42 TL
- Pressure	bar	3,5

<b>HYDROSTATIC TRANSMISSION</b>		
Hydrostatic Pump		REXROTH
- Type		A4VG56DA
- Gear Reverser		ELECTROHYDRAULIC
- Inching Control		HYDRAULIC VALVE TH7
- Number of forward gears		2
- Number of reverse gears		2
Main Pump		
• Min. Max Displacement		0-56 cm3 (3.42 cu in)
• Minimum Capacity		0 cm3/t
• Max. Flow Rate		210 L/min (55.47 gal/min)
• Working pressure		7251 psi
Boost Pump		
• Displacement		19.6 cm3/t
• Max. Flow Rate		58 l/mn
• Boost Pressure MAX. RPM		30 bar, Transmission au neutre
Hydrostatic Motor		REXROTH (Variable Displacement)
- Type		A6VM107DA1/63W
- Min. - Max. displacement	cm3/t	32-107

<b>ELECTRIC CIRCUIT</b>		
Battery	STANDARD	12 V - 110 Ah - 900 A EN
	OPTION	12 V - 180 Ah - 900 A EN
Alternator		12 V - 100 A
- Type		ISKRA AAK-EF12V
Starter		12 V - 3,2 kW
- Type		ISKRA AZE

<b>BRAKE CIRCUIT</b>		
Service brake		Non-servo hydraulic brake
- Type of brake		Multidisc brake immersed in oil
- Type of control		By foot on front wheels
Parking brake		Mechanical
- Type of brake		Multidisc brake immersed in oil
- Type of control		Manual

<b>HYDRAULIC MOVEMENTS</b>		
Lifting movements		
- Unladen lifting	m/s	0,5
- Laden lifting	m/s	0,5
- Unladen lowering	m/s	0,5
- Laden lowering	m/s	0,5

<b>SOUND AND VIBRATION</b>		
Sound pressure level in the driver's cab LpA (according to standard NF EN 12053)	dB	76
Sound pressure level ensured in the LwA environment (according to directive 2000/14/EC modified by directive 2005/88/EC)	dB	104 (measured) 105 (ensured)
Average weighted acceleration on driver's body (according to standard NF EN 13059)	m/s <sup>2</sup>	1
The average weighted acceleration transmitted to the driver's hand/arm system (according to standard ISO 5349-2)	m/s <sup>2</sup>	< 2,5

<b>SPECIFICATIONS AND WEIGHTS</b>		
Speed of movement for lift truck in standard configuration on flat ground (except particular conditions)		
Forward unladen		
1	km/h	3,4
2	km/h	6,4
3	km/h	12,4
4	km/h	21,6
Rear unladen		
1	km/h	3,4
2	km/h	6,4
3	km/h	12,4
4	km/h	21,6
Hydrostatic (Loaded Unloaded Approx.)		
- Low Gear	km/h	8
- High Gear	km/h	24
		* Hydrostatic (not yet determined)
Standard mast		DVT 3M70
- Lift height	mm	3700
- Free lift height	mm	130
- Overall height (retracted)	mm	2705
- Overall height (extended)	mm	4735
Carriage		
- Class		FEM3
- width	mm	1470
- Mass of forks (each one)	kg	73
Rated load capacity	kg	3000
Rated load capacity with standard mast	kg	3000
Effective load capacity on forks with side-shift carriage	kg	3000
Distance from the centre of gravity of the load to the base of the forks	mm	500
Lift truck mass without forks or mast	kg	4476
Lift truck mass with standard mast		
- Unladen	kg	5485
- At rated load	kg	8485
Axle mass with standard mast (transport position)		
- Front unladen	kg	2155
- Rear unladen	kg	3330
- Front rated load	kg	7000
- Rear rated load	kg	1485
Drag strain on the coupling hook		
- Unladen (sliding)	daN	4250
- At rated load (transmission setting)	daN	6290
Pull strain with open carrier (according to standard ISO 8313)	daN	

HYDRAULIC CIRCUIT			
Hydraulic pump		PARKER	
- Type		Gear	
		1st casing	2nd casing
- Capacity	cm <sup>3</sup>	31	14
- Max. rating capacity unladen	l/min	97	44
- Flow rate at 1800 rpm	l/min		
Filtration			
- Return	µm	10	
- Suction	µm	125	
Maximum service pressure			
- Double mast with all-round vision	bar	245	
- Triple mast with free-acting lift	bar	260	
- Double mast with free-acting lift	bar	185	
- Triple mast without free-acting lift	bar	260	
- Front/rear tilting circuit	bar	185/185	
- Attachment circuit	bar	185	
- Steering circuit	bar	145	
- Hydraulic shock absorber			
- Capacity	L	0,7	
- Pressure	bar	100	

<b>I.C. ENGINE</b>		
Type		PERKINS 854F-E34T 54009,1,1
Fuel		Diesel
Number of cylinders		4 in line
Suction		Supercharged
Injection system		Direct
Ignition sequence		1.3.4.2
Capacity	cm3	3400
Bore and stroke	mm	99 x 110
Compression ratio		17:1
Nominal rating loaded	rpm	2200
Rating slow unladen	rpm	850
Max. rating unladen	rpm	3125
Power ISO/TR 14396	hp- kW	75 - 55,5
Power SAE J 1995	hp- kW	75 - 55,5
Maximum torque ISO/TR 14396	Nm	318 to 1400 rpm
Air cleaner	µm	3
Type of cooling		By water
Fan		Puller

<b>TRANSMISSION</b>		
Gear box		TURNER POWERTRAIN SYSTEMS
- Type		Mechanical
- Forward/reverse selector		Electro-hydraulic
- Torque converter		SACHS
- Number of forward speeds		4
- Number of reverse speeds		4
Front axle		DANA
- Differential		Without locking
Rear axle		DANA
- Differential		Without locking
Drive wheels		2 RWD
- Switch for 2/4 drive wheels		No
Front tyres		EVEREST
- Size		18X19.5 18PR 8T P30 TUB
- Pressure	bar	4,5
Rear tyres		GOODYEAR
- Size		10R 17.5 134/132M G291 GY
- Pressure	bar	3.2

<b>HYDROSTATIC TRANSMISSION</b>		
Hydrostatic Pump		REXROTH
- Type		A4VG56DA
- Gear Reverser		ELECTROHYDRAULIC
- Inching Control		HYDRAULIC VALVE TH7
- Number of forward gears		1
- Number of reverse gears		1
Main Pump		
• Min. Max Displacement		0-71 cm3 (3.42 cu in)
• Minimum Capacity		0 cm3/t
• Max. Flow Rate		210 L/min (55.47 gal/min)
• Working pressure		7251 psi
Boost Pump		
• Displacement		19.6 cm3/t
• Max. Flow Rate		58 l/mn
• Boost Pressure MAX. RPM		30 bar, Transmission au neutre
Hydrostatic Motor		REXROTH (Variable Displacement)
- Type		A6VM107DA1/63W
- Min. - Max. displacement	cm3/t	28-28

<b>ELECTRIC CIRCUIT</b>		
Battery	STANDARD	12 V - 110 Ah - 900 A EN
	OPTION	12 V - 180 Ah - 900 A EN
Alternator		12 V - 100 A
- Type		ISKRA AAK-EF12V
Starter		12 V - 3,2 kW
- Type		ISKRA AZE

BRAKE CIRCUIT	
Service brake	Non-servo hydraulic brake
- Type of brake	Multidisc brake immersed in oil
- Type of control	By foot on front wheels
Parking brake	Mechanical
- Type of brake	Multidisc brake immersed in oil
- Type of control	Manual

HYDRAULIC MOVEMENTS	
Lifting movements	
- Unladen lifting	m/s 0,4
- Laden lifting	m/s 0,4
- Unladen lowering	m/s 0,3
- Laden lowering	m/s 0,4

SOUND AND VIBRATION	
Sound pressure level in the driver's cab LpA (according to standard NF EN 12053)	dB 76
Sound pressure level ensured in the LwA environment (according to directive 2000/14/EC modified by directive 2005/88/EC)	dB 104 (measured) 105 (ensured)
Average weighted acceleration on driver's body (according to standard NF EN 13059)	m/s <sup>2</sup> 1,2
The average weighted acceleration transmitted to the driver's hand/arm system (according to standard ISO 5349-2)	m/s <sup>2</sup> < 2,5

SPECIFICATIONS AND WEIGHTS	
Speed of movement for lift truck in standard configuration on flat ground (except particular conditions)	
Forward unladen	1 km/h 3,9
	2 km/h 7.3
	3 km/h 14.0
	4 km/h 24.0
Rear unladen	1 km/h 3,9
	2 km/h 7.3
	3 km/h 14.0
	4 km/h 24.0
Hydrostatic (Loaded/Unloaded Approx.)	
- Low Gear	km/h 8
- High Gear	km/h 24
	<b>HYDROSTATIC</b>
Standard mast	DVT 3M70 TLL 5M50
- Lift height	mm 3700 5500
- Free lift height	mm
- Overall height (retracted)	mm 2910
- Overall height (extended)	mm 4815
Carriage	
- Class	FEM3
- width	mm 1670 2000
- Mass of forks (each one)	kg 73 100
Rated load capacity	kg 4000
Rated load capacity with standard mast	kg 4000
Effective load capacity on forks with side-shift carriage	kg 4000
Distance from the centre of gravity of the load to the base of the forks	mm 600
Lift truck mass without forks or mast	kg 5804 5725
Lift truck mass with standard mast	
- Unladen	kg 8005 7600
- At rated load	kg 13005 11600
Axle mass with standard mast (transport position)	
- Front unladen	kg Less than 3374 3628
- Rear unladen	kg Less than 4816 3983
- Front rated load	kg Less than 11610 10228
- Rear rated load	kg Less than 1580 1383
Drag strain on the coupling hook	
- Unladen (sliding)	daN TBD
- At rated load (transmission setting)	daN TBD
Pull strain with open carrier (according to standard ISO 8313)	daN

HYDRAULIC CIRCUIT			
Hydraulic pump		PARKER	
- Type		Gear	
		1st casing	2nd casing
- Capacity	cm <sup>3</sup>	31	14
- Max. rating capacity unladen	l/min	97	44
- Flow rate at 1800 rpm	l/min		
Filtration			
- Return	µm	10	
- Suction	µm	125	
Maximum service pressure			
- Double mast with all-round vision	bar	230	
- Triple mast with free-acting lift	bar	250	
- Double mast with free-acting lift	bar	240	
- Triple mast without free-acting lift	bar	-	
- Front/rear tilting circuit	bar	210/210	
- Attachment circuit	bar	210	
- Steering circuit	bar	145	
- Hydraulic shock absorber			
- Capacity	L	1,4	
- Pressure	bar	120	

<b>I.C. ENGINE</b>		
Type		PERKINS 854F-E34T 54009,1,1
Fuel		Diesel
Number of cylinders		4 in line
Suction		Supercharged
Injection system		Direct
Ignition sequence		1.3.4.2
Capacity	cm <sup>3</sup>	3400
Bore and stroke	mm	99 x 110
Compression ratio		17:1
Nominal rating loaded	rpm	2200
Rating slow unladen	rpm	850
Max. rating unladen	rpm	3125
Power ISO/TR 14396	hp- kW	75 - 55,5
Power SAE J 1995	hp- kW	75 - 55,5
Maximum torque ISO/TR 14396	Nm	318 to 1400 rpm
Air cleaner	µm	3
Type of cooling		By water
Fan		Puller

<b>TRANSMISSION</b>		
Gear box		TURNER POWERTRAIN SYSTEMS
- Type		Mechanical
- Forward/reverse selector		Electro-hydraulic
- Torque converter		SACHS
- Number of forward speeds		4
- Number of reverse speeds		4
Front axle		DANA
- Differential		With locking
Rear axle		MANITOU
- Differential		Without locking
Drive wheels		4 WD Permanent
- Switch for 2/4 drive wheels		Yes
Front tyres		MITAS
- Size		18-22,5 163A8 MPT-06 TL
- Pressure	bar	4,5
Rear tyres		MICHELIN
- Size		340/80R18 XMCL 143A8
- Pressure	bar	3.2

<b>HYDROSTATIC TRANSMISSION</b>		
Hydrostatic Pump		REXROTH
- Type		A4VG56DA
- Gear Reverser		ELECTROHYDRAULIC
- Inching Control		HYDRAULIC VALVE TH7
- Number of forward gears		2
- Number of reverse gears		2
Main Pump		
• Min. Max Displacement		0-56 cm <sup>3</sup> (3.42 cu in)
• Minimum Capacity		0 cm <sup>3</sup> /t
• Max. Flow Rate		210 L/min (55.47 gal/min)
• Working pressure		7251 psi
Boost Pump		
• Displacement		19.6 cm <sup>3</sup> /t
• Max. Flow Rate		58 l/mn
• Boost Pressure MAX. RPM		30 bar, Transmission au neutre
Hydrostatic Motor		REXROTH (Variable Displacement)
- Type		A6VM107DA1/63W
- Min. - Max. displacement	cm <sup>3</sup> /t	32-107

<b>ELECTRIC CIRCUIT</b>		
Battery	STANDARD	12 V - 110 Ah - 900 A EN
	OPTION	12 V - 180 Ah - 900 A EN
Alternator		12 V - 100 A
- Type		ISKRA AAK-EF12V
Starter		12 V - 3,2 kW
- Type		ISKRA AZE

BRAKE CIRCUIT		
Service brake		Servo hydraulic brake
- Type of brake		Multidisc brake immersed in oil
- Type of control		By foot on front wheels
Parking brake		Mechanical
- Type of brake		Multidisc brake immersed in oil
- Type of control		Manual

HYDRAULIC MOVEMENTS		
Lifting movements		
- Unladen lifting	m/s	0,5
- Laden lifting	m/s	0,4
- Unladen lowering	m/s	0,4
- Laden lowering	m/s	0,5

SOUND AND VIBRATION		
Sound pressure level in the driver's cab LpA (according to standard NF EN 12053)	dB	76
Sound pressure level ensured in the LwA environment (according to directive 2000/14/EC modified by directive 2005/88/EC)	dB	104 (measured) 104 (ensured)
Average weighted acceleration on driver's body (according to standard NF EN 13059)	m/s <sup>2</sup>	1,156
The average weighted acceleration transmitted to the driver's hand/arm system (according to standard ISO 5349-2)	m/s <sup>2</sup>	< 2,5

SPECIFICATIONS AND WEIGHTS			
Speed of movement for lift truck in standard configuration on flat ground (except particular conditions)			
Forward unladen	1	km/h	3,6
	2	km/h	6,6
	3	km/h	12,6
	4	km/h	23,9
Rear unladen	1	km/h	3,6
	2	km/h	6,6
	3	km/h	12,6
	4	km/h	23,9
Hydrostatic (Loaded/Unloaded Approx.)			
- Low Gear		km/h	8
- High Gear		km/h	24
			<b>HYDROSTATIC</b>
Standard mast			DVT 3M70    TLL 5M50
- Lift height		mm	3700    5500
- Free lift height		mm	
- Overall height (retracted)		mm	2855
- Overall height (extended)		mm	4750
Carriage			
- Class			FEM3
- width		mm	1670    2000
- Mass of forks (each one)		kg	73    100
Rated load capacity		kg	4000
Rated load capacity with standard mast		kg	4000
Effective load capacity on forks with side-shift carriage		kg	4000
Distance from the centre of gravity of the load to the base of the forks		mm	600
Lift truck mass without forks or mast		kg	5542    5725
Lift truck mass with standard mast			
- Unladen		kg	7735    7600
- At rated load		kg	12735    11600
Axle mass with standard mast (transport position)			
- Front unladen		kg	Less Than 2645    3628
- Rear unladen		kg	Less Than 5275    3983
- Front rated load		kg	Less Than 10895    10228
- Rear rated load		kg	Less Than 2025    1383
Drag strain on the coupling hook			
- Unladen (sliding)		daN	TBD
- At rated load (transmission setting)		daN	TBD
Pull strain with open carrier (according to standard ISO 8313)		daN	

HYDRAULIC CIRCUIT			
Hydraulic pump		PARKER	
- Type		Gear	
		1st casing	2nd casing
- Capacity	cm <sup>3</sup>	31	14
- Max. rating capacity unladen	l/min	97	44
- Flow rate at 1800 rpm	l/min		
Filtration			
- Return	µm	10	
- Suction	µm	125	
Maximum service pressure			
- Double mast with all-round vision	bar	230	
- Triple mast with free-acting lift	bar	250	
- Double mast with free-acting lift	bar	240	
- Triple mast without free-acting lift	bar	-	
- Front/rear tilting circuit	bar	210/210	
- Attachment circuit	bar	210	
- Steering circuit	bar	145	
- Hydraulic shock absorber			
- Capacity	L	1,4	
- Pressure	bar	120	

<b>I.C. ENGINE</b>		
Type		PERKINS 854F-E34T 54009,1,1
Fuel		Diesel
Number of cylinders		4 in line
Suction		Supercharged
Injection system		Direct
Ignition sequence		1.3.4.2
Capacity	cm <sup>3</sup>	3400
Bore and stroke	mm	99 x 110
Compression ratio		17:1
Nominal rating loaded	rpm	2200
Rating slow unladen	rpm	850
Max. rating unladen	rpm	3125
Power ISO/TR 14396	hp- kW	75 - 55,5
Power SAE J 1995	hp- kW	75 - 55,5
Maximum torque ISO/TR 14396	Nm	318 to 1400 rpm
Air cleaner	µm	3
Type of cooling		By water
Fan		Puller

<b>TRANSMISSION</b>		
Gear box		TURNER POWERTRAIN SYSTEMS
- Type		Mechanical
- Forward/reverse selector		Electro-hydraulic
- Torque converter		SACHS
- Number of forward speeds		4
- Number of reverse speeds		4
Front axle		DANA
- Differential		Without locking
Rear axle		MANITOU
- Differential		With locking
Drive wheels		2RM Permanent
- Switch for 2/4 drive wheels		No
Front tyres		EVEREST
- Size		18X19,5 18PR 8T P30 TUB
- Pressure	bar	6,5
Rear tyres		GOODYEAR
- Size		10R17,5 134/132M G291 GY
- Pressure	bar	9,5

<b>HYDROSTATIC TRANSMISSION</b>		
Hydrostatic Pump		REXROTH
- Type		A4VG56DA
- Gear Reverser		ELECTROHYDRAULIC
- Inching Control		HYDRAULIC VALVE TH7
- Number of forward gears		1
- Number of reverse gears		1
Main Pump		
• Min. Max Displacement		0-71 cm <sup>3</sup> (3.42 cu in)
• Minimum Capacity		0 cm <sup>3</sup> /t
• Max. Flow Rate		210 L/min (55.47 gal/min)
• Working pressure		7251 psi
Boost Pump		
• Displacement		<b>19.6 cm<sup>3</sup>/t</b>
• Max. Flow Rate		<b>58 l/mn</b>
• Boost Pressure MAX. RPM		<b>30 bar, Transmission au neutre</b>
Hydrostatic Motor		REXROTH (Variable Displacement)
- Type		A6VM107DA1/63W
- Min. - Max. displacement	cm <sup>3</sup> /t	28-28

<b>ELECTRIC CIRCUIT</b>		
Battery	STANDARD	12 V - 110 Ah - 900 A EN
	OPTION	12 V - 180 Ah - 900 A EN
Alternator		12 V - 100 A
- Type		ISKRA AAK-EF12V
Starter		12 V - 3,2 kW
- Type		ISKRA AZE

BRAKE CIRCUIT		
Service brake		Non-servo hydraulic brake
- Type of brake		Multidisc brake immersed in oil
- Type of control		By foot on front wheels
Parking brake		Mechanical
- Type of brake		Multidisc brake immersed in oil
- Type of control		Manual

HYDRAULIC MOVEMENTS		
Lifting movements		
- Unladen lifting	m/s	0,5
- Laden lifting	m/s	0,4
- Unladen lowering	m/s	0,4
- Laden lowering	m/s	0,5

SOUND AND VIBRATION		
Sound pressure level in the driver's cab LpA (according to standard NF EN 12053)	dB	76
Sound pressure level ensured in the LwA environment (according to directive 2000/14/EC modified by directive 2005/88/EC)	dB	104 (measured) 105 (ensured)
Average weighted acceleration on driver's body (according to standard NF EN 13059)	m/s <sup>2</sup>	1,2
The average weighted acceleration transmitted to the driver's hand/arm system (according to standard ISO 5349-2)	m/s <sup>2</sup>	< 2,5

SPECIFICATIONS AND WEIGHTS			
Speed of movement for lift truck in standard configuration on flat ground (except particular conditions)			
Forward unladen	1	km/h	3,6
	2	km/h	6,6
	3	km/h	12,6
	4	km/h	23,9
Rear unladen	1	km/h	3,6
	2	km/h	6,6
	3	km/h	12,6
	4	km/h	23,9
Hydrostatic (Loaded/Unloaded Approx.)			
- Low Gear		km/h	8
- High Gear		km/h	24
			* Hydrostatic (not yet determined)
Standard mast			DVT 3M70    TBD
- Lift height		mm	3700    TBD
- Free lift height		mm	
- Overall height (retracted)		mm	2855
- Overall height (extended)		mm	4750
Carriage			
- Class			FEM4
- width		mm	1670    TBD
- Ground of forks (each one)		kg	134    TBD
Rated load capacity		kg	5000
Rated load capacity with standard mast		kg	5000
Effective load capacity on forks with side-shift carriage		kg	4500
Distance from the centre of gravity of the load to the base of the forks		mm	600
Lift truck mass without forks or mast			
- Unladen		kg	
- At rated load		kg	
Axle mass with standard mast (transport position)			
- Front unladen		kg	
- Rear unladen		kg	
- Front rated load		kg	
- Rear rated load		kg	
Drag strain on the coupling hook			
- Unladen (sliding)		daN	
- At rated load (transmission setting)		daN	
Pull strain with open carrier (according to standard ISO 8313)			
		daN	

HYDRAULIC CIRCUIT			
Hydraulic pump		PARKER	
- Type		Gear	
		1st casing	2nd casing
- Capacity	cm <sup>3</sup>	31	14
- Max. rating capacity unladen	l/min	97	44
- Flow rate at 1800 rpm	l/min		
Filtration			
- Return	µm	10	
- Suction	µm	125	
Maximum service pressure			
- Double mast with all-round vision	bar	230	
- Triple mast with free-acting lift	bar	250	
- Double mast with free-acting lift	bar	240	
- Triple mast without free-acting lift	bar	-	
- Front/rear tilting circuit	bar	210/210	
- Attachment circuit	bar	210	
- Steering circuit	bar	145	
- Hydraulic shock absorber			
- Capacity	L	1,4	
- Pressure	bar	120	

<b>I.C. ENGINE</b>		
Type		PERKINS 854F-E34T 54009,1,1
Fuel		Diesel
Number of cylinders		4 in line
Suction		Supercharged
Injection system		Direct
Ignition sequence		1.3.4.2
Capacity	cm3	3400
Bore and stroke	mm	99 x 110
Compression ratio		17:1
Nominal rating loaded	rpm	2200
Rating slow unladen	rpm	850
Max. rating unladen	rpm	3125
Power ISO/TR 14396	hp- kW	75 - 55,5
Power SAE J 1995	hp- kW	75 - 55,5
Maximum torque ISO/TR 14396	Nm	318 to 1400 rpm
Air cleaner	µm	3
Type of cooling		By water
Fan		Puller

<b>TRANSMISSION</b>		
Gear box		TURNER POWERTRAIN SYSTEMS
- Type		Mechanical
- Forward/reverse selector		Electro-hydraulic
- Torque converter		SACHS
- Number of forward speeds		4
- Number of reverse speeds		4
Front axle		DANA
- Differential		With locking
Rear axle		DANA
- Differential		Without locking
Drive wheels		4RM
- Switch for 2/4 drive wheels		Yes
Front tyres		MITAS
- Size		18-22,5 163A8 MPT-06 TL
- Pressure	bar	4,5
Rear tyres		MICHELIN
- Size		340/80R18 XMCL 143A8
- Pressure	bar	3,2

<b>HYDROSTATIC TRANSMISSION</b>		
Hydrostatic Pump		REXROTH
- Type		A4VG56DA
- Gear Reverser		ELECTROHYDRAULIC
- Inching Control		HYDRAULIC VALVE TH7
- Number of forward gears		2
- Number of reverse gears		2
Main Pump		
• Min. Max Displacement		0-56 cm3 (3.42 cu in)
• Minimum Capacity		0 cm3/t
• Max. Flow Rate		210 L/min (55.47 gal/min)
• Working pressure		7251 psi
Boost Pump		
• Displacement		19.6 cm3/t
• Max. Flow Rate		58 l/mn
• Boost Pressure MAX. RPM		30 bar, Transmission au neutre
Hydrostatic Motor		REXROTH (Variable Displacement)
- Type		A6VM107DA1/63W
- Min. - Max. displacement	cm3/t	32-107

<b>ELECTRIC CIRCUIT</b>		
Battery	STANDARD	12 V - 110 Ah - 900 A EN
	OPTION	12 V - 180 Ah - 900 A EN
Alternator		12 V - 100 A
- Type		ISKRA AAK-EF12V
Starter		12 V - 3,2 kW
- Type		ISKRA AZE

BRAKE CIRCUIT		
Service brake		Non-servo hydraulic brake
- Type of brake		Multidisc brake immersed in oil
- Type of control		By foot on front wheels
Parking brake		Mechanical
- Type of brake		Multidisc brake immersed in oil
- Type of control		Manual

HYDRAULIC MOVEMENTS		
Lifting movements		
- Unladen lifting	m/s	0,4
- Laden lifting	m/s	0,4
- Unladen lowering	m/s	0,3
- Laden lowering	m/s	0,4

SOUND AND VIBRATION		
Sound pressure level in the driver's cab LpA (according to standard NF EN 12053)	dB	76
Sound pressure level ensured in the LwA environment (according to directive 2000/14/EC modified by directive 2005/88/EC)	dB	104 (measured) 105 (ensured)
Average weighted acceleration on driver's body (according to standard NF EN 13059)	m/s <sup>2</sup>	1,2
The average weighted acceleration transmitted to the driver's hand/arm system (according to standard ISO 5349-2)	m/s <sup>2</sup>	< 2,5

SPECIFICATIONS AND WEIGHTS		
Speed of movement for lift truck in standard configuration on flat ground (except particular conditions)		
Forward unladen	1 km/h	3,9
	2 km/h	7,3
	3 km/h	14,0
	4 km/h	24,0
Rear unladen	1 km/h	3,9
	2 km/h	7,3
	3 km/h	14,0
	4 km/h	24,0
Hydrostatic (Loaded/Unloaded Approx.)		
- Low Gear	km/h	8
- High Gear	km/h	24
		* Hydrostatic (not yet determined)
Standard mast		DVT 3M70
- Lift height	mm	3700 TBD
- Free lift height	mm	
- Overall height (retracted)	mm	2910
- Overall height (extended)	mm	4815
Carriage		
- Class		FEM4
- width	mm	1670
- Mass of forks (each one)	kg	138 TBD
Rated load capacity	kg	5000
Rated load capacity with standard mast	kg	5000
Effective load capacity on forks with side-shift carriage	kg	4500
Distance from the centre of gravity of the load to the base of the forks	mm	600
Lift truck mass without forks or mast	kg	6604
Lift truck mass with standard mast		
- Unladen	kg	8190 TBD
- At rated load	kg	13190 TBD
Axle mass with standard mast (transport position)		
- Front unladen	kg	3374
- Rear unladen	kg	4816
- Front rated load	kg	11610
- Rear rated load	kg	1580
Drag strain on the coupling hook		
- Unladen (sliding)	daN	6240
- At rated load (transmission setting)	daN	10220
Pull strain with open carrier (according to standard ISO 8313)	daN	

<b>HYDRAULIC CIRCUIT</b>			
Hydraulic pump		PARKER	
- Type		Gear	
		1st casing	2nd casing
- Capacity	cm <sup>3</sup>	31	14
- Max. rating capacity unladen	l/min	97	44
- Flow rate at 1800 rpm	l/min		
Filtration			
- Return	µm	10	
- Suction	µm	125	
Maximum service pressure			
- Double mast with all-round vision	bar	230	
- Triple mast with free-acting lift	bar	250	
- Double mast with free-acting lift	bar	240	
- Triple mast without free-acting lift	bar	-	
- Front/rear tilting circuit	bar	210/210	
- Attachment circuit	bar	210	
- Steering circuit	bar	145	
- Hydraulic shock absorber			
- Capacity	L	1,4	
- Pressure	bar	120	

DOUBLE MAST WITH ALL-ROUND VISION							
MAST	HL	Z	Y	LL	H	H1	H2
3m00	3030	6°	12°	130	2305	4045	290
3m30	3330	6°	12°	130	2455	4345	290
3m50	3530	6°	12°	130	2555	4545	290
3m70	3730	6°	12°	130	2715	4745	230
4m00	4030	6°	12°	130	2905	5045	190
4m50	4530	6°	12°	130	3155	5545	190
5m00	5030	6°	12°	130	3405	6045	190
5m50	5530	6°	12°	130	3655	6545	190
6m00	6030	6°	12°	130	4015	7195	190

DOUBLE MAST WITH TOTAL FREE-ACTING LIFT							
MAST	HL	Z	Y	LL	H	H1	H2
3m00	3040	6°	12°	1383	2375	4032	167
3m30	3340	6°	12°	1533	2525	4332	167
3m50	3540	6°	12°	1633	2625	4532	167
3m70	3740	6°	12°	1793	2785	4732	167
4m00	4040	6°	12°	1983	2975	5032	167
4m50	4540	6°	12°	2233	3225	5532	167

TRIPLE MAST WITH TOTAL FREE-ACTING LIFT							
MAST	HL	Z	Y	LL	H	H1	H2
3m70	3740	6°	12°	1283	2275	4732	47
4m00	4040	6°	12°	1383	2375	5032	47
4m30	4340	6°	12°	1533	2525	5332	47
4m70	4740	6°	12°	1633	2625	5732	47
5m00	5040	6°	12°	1793	2785	6032	47
5m50	5540	6°	12°	1983	2975	6532	47
6m00	6040	6°	12°	2233	3225	7032	47
6m50	6540	6°	12°	2483	3475	7532	47
7m00	7040	6°	12°	2733	3725	8032	47

TRIPLE MAST WITHOUT FREE-ACTING LIFT							
MAST	HL	Z	Y	LL	H	H1	H2
5m505	5545	6°	10°	0	3055	6725	0

- HL: Lift height in mm
- Z: Forward tilting
- Y: Backward tilting
- LL: Free-acting lift in mm
- H: Overall height with folded mast in mm
- H1: Overall height with spread out mast in mm
- H2: Carriage overshooting in mm

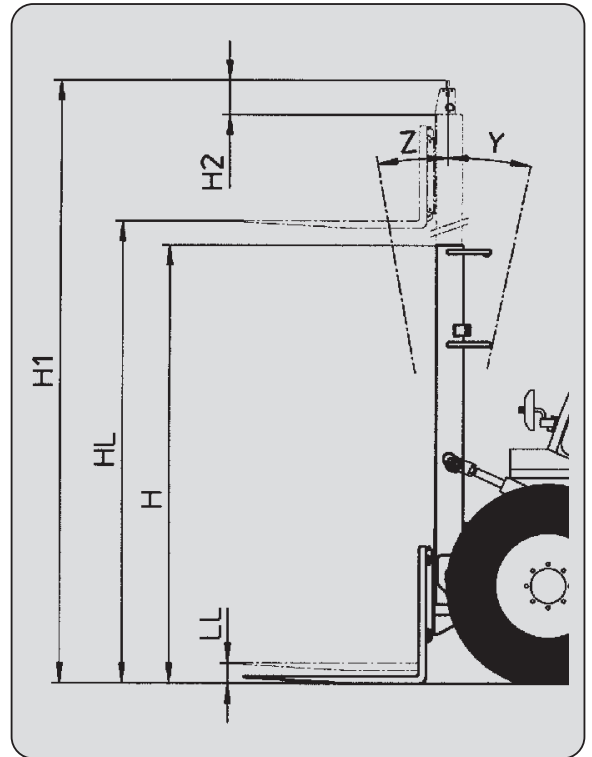

DOUBLE MAST WITH ALL-ROUND VISION							
MAST	HL	Z	Y	LL	H	H1	H2
3m00	3030	6°	12°	130	2305	4045	290
3m30	3330	6°	12°	130	2455	4345	290
3m50	3530	6°	12°	130	2555	4545	290
3m70	3730	6°	12°	130	2715	4745	230
4m00	4030	6°	12°	130	2905	5045	190
4m50	4530	6°	12°	130	3155	5545	190
5m00	5030	6°	12°	130	3405	6045	190
5m50	5530	6°	12°	130	3655	6545	190
6m00	6030	6°	12°	130	4015	7195	190

DOUBLE MAST WITH TOTAL FREE-ACTING LIFT							
MAST	HL	Z	Y	LL	H	H1	H2
3m00	3040	6°	12°	1383	2305	3962	167
3m30	3340	6°	12°	1533	2455	4262	167
3m50	3540	6°	12°	1633	2555	4462	167
3m70	3740	6°	12°	1793	2715	4662	167
4m00	4040	6°	12°	1983	2905	4962	167
4m50	4540	6°	12°	2233	3155	5462	167

TRIPLE MAST WITH TOTAL FREE-ACTING LIFT							
MAST	HL	Z	Y	LL	H	H1	H2
3m70	3740	6°	12°	1283	2205	4662	47
4m00	4040	6°	12°	1383	2305	4962	47
4m30	4340	6°	12°	1533	2455	5262	47
4m70	4740	6°	12°	1633	2555	5662	47
5m00	5040	6°	12°	1793	2715	5962	47
5m50	5540	6°	12°	1983	2905	6462	47
6m00	6040	6°	12°	2233	3155	6962	47
6m50	6540	6°	12°	2483	3405	7462	47
7m00	7040	6°	12°	2733	3655	7962	47

TRIPLE MAST WITHOUT FREE-ACTING LIFT							
MAST	HL	Z	Y	LL	H	H1	H2
5m505	5545	6°	10°	0	2985	6655	0

- HL: Lift height in mm
- Z: Forward tilting
- Y: Backward tilting
- LL: Free-acting lift in mm
- H: Overall height with folded mast in mm
- H1: Overall height with spread out mast in mm
- H2: Carriage overshooting in mm

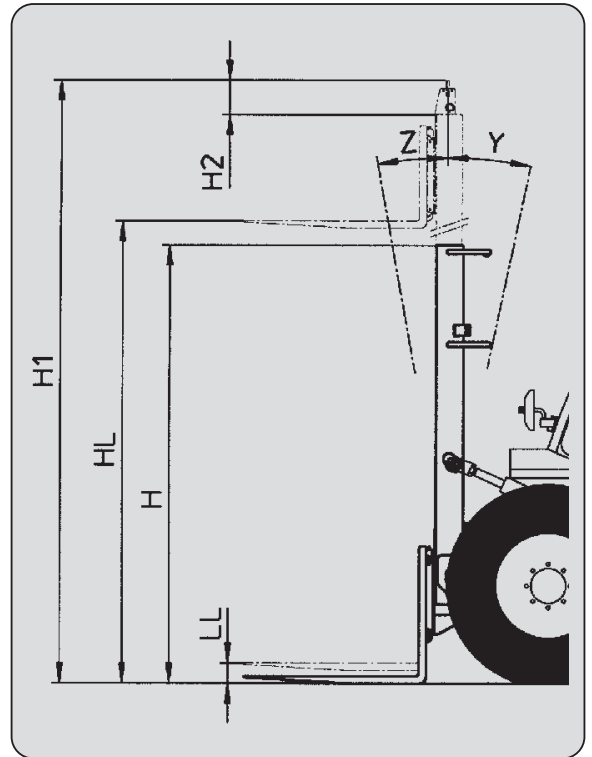

DOUBLE MAST WITH ALL-ROUND VISION							
MAST	HL	Z	Y	LL	H	H1	H2
3m00	3050	15°	15°	0	2560	4115	55
3m30	3350	15°	15°	0	2710	4415	55
3m50	3550	15°	15°	0	2810	4615	55
3m70	3750	15°	15°	0	2910	4815	55
4m00	4050	15°	15°	0	3060	5115	55
4m50	4550	15°	15°	0	3305	5615	55
5m00	5050	15°	15°	0	3560	6115	55

DOUBLE MAST WITH TOTAL FREE-ACTING LIFT							
MAST	HL	Z	Y	LL	H	H1	H2
3m00	3050	15°	15°	1518	2585	4117	32
3m30	3350	15°	15°	1668	2735	4417	32
3m50	3550	15°	15°	1768	2835	4617	32
3m70	3750	15°	15°	1868	2935	4817	32
4m00	4050	15°	15°	1968	3085	5517	32

TRIPLE MAST WITH TOTAL FREE-ACTING LIFT							
MAST	HL	Z	Y	LL	H	H1	H2
3m70	3750	15°	15°	1255	2310	4805	45
4m00	4050	15°	15°	1355	2410	5105	45
4m30	4350	15°	15°	1455	2510	5405	45
4m50	4550	15°	15°	1530	2585	5605	20
4m70	4750	15°	15°	1590	2645	5805	40
5m00	5050	10°	15°	1705	2760	6105	15
5m50	5550	10°	15°	1855	2910	6605	45
6m00	6050	10°	15°	2030	3085	7105	20

- HL: Lift height in mm
- Z: Forward tilting
- Y: Backward tilting
- LL: Free-acting lift in mm
- H: Overall height with folded mast in mm
- H1: Overall height with spread out mast in mm
- H2: Carriage overshooting in mm

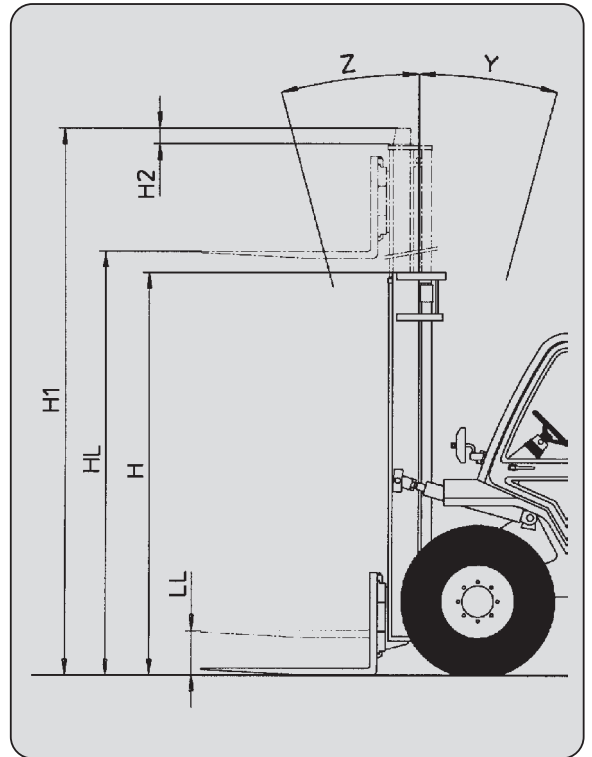

DOUBLE MAST WITH ALL-ROUND VISION							
MAST	HL	Z	Y	LL	H	H1	H2
3m00	3060	15°	15°	0	2560	4115	55
3m30	3360	15°	15°	0	2710	4415	55
3m50	3560	15°	15°	0	2810	4615	55
3m70	3760	15°	15°	0	2910	4815	55
4m00	4060	15°	15°	0	3060	5115	55
4m50	4560	15°	15°	0	3305	5615	55
5m00	5060	15°	15°	0	3560	6115	55
5m50	5560	15°	15°	0	3810	6615	55

DOUBLE MAST WITH TOTAL FREE-ACTING LIFT							
MAST	HL	Z	Y	LL	H	H1	H2
3m00	3060	15°	15°	1528	2585	4117	32
3m30	3360	15°	15°	1678	2735	4417	32
3m50	3560	15°	15°	1778	2835	4617	32
3m70	3760	15°	15°	1878	2935	4817	32
4m00	4060	15°	15°	1978	3085	5517	32

TRIPLE MAST WITH TOTAL FREE-ACTING LIFT							
MAST	HL	Z	Y	LL	H	H1	H2
3m70	3760	15°	15°	1265	2310	4805	45
4m00	4060	15°	15°	1365	2410	5105	45
4m30	4360	15°	15°	1465	2510	5405	45
4m50	4560	15°	15°	1540	2585	5605	20
4m70	4760	15°	15°	1600	2645	5805	40
5m00	5060	10°	15°	1715	2760	6105	15
5m50	5560	10°	15°	1865	2910	6605	45
6m00	6060	10°	15°	2040	3085	7105	20

- HL: Lift height in mm
- Z: Forward tilting
- Y: Backward tilting
- LL: Free-acting lift in mm
- H: Overall height with folded mast in mm
- H1: Overall height with spread out mast in mm
- H2: Carriage overshooting in mm

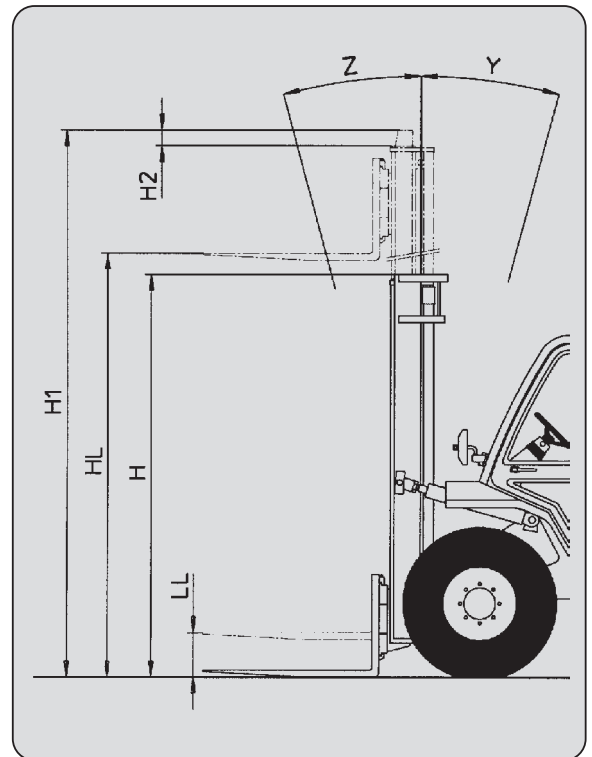

# TIRES

M 26/30-2+H ST3B		PRESSURE (bar)	LOAD PER TYRE (kg)			
			FRONT UNLADEN	FRONT LADEN	REAR UNLADEN	REAR LADEN
CONTINENTAL	14,5R20 MPT80 18PR 143G/J TUBELESS	3,5	1050	3450		
MICHELIN	380/75 R20 XMCL 148A8 TUBELESS	3,5				
GOODYEAR	10R17,5 G291 134M	5,5			1600	700

M 26/30-4+H ST3B		PRESSURE (bar)	LOAD PER TYRE (kg)			
			FRONT UNLADEN	FRONT LADEN	REAR UNLADEN	REAR LADEN
DUNLOP	400/70-20 T37 150B TUBELESS	2,3	1100	3500		
MICHELIN	380/75 R20 XMCL 148A8 TUBELESS	3,5				
DUNLOP	10,5/80-18 TG42 10PR TUBELESS	3,5			1650	750

M 40/50-2+H ST3B		PRESSURE (bar)	LOAD PER TYRE (kg)			
			FRONT UNLADEN	FRONT LADEN	REAR UNLADEN	REAR LADEN
ALLIANCE	18-19,5 A224 18PR TUBELESS	6,5				
MICHELIN	18R19,5 XF TUBELESS	6,5				
GOODYEAR	10R17,5 G291 134M	9,5				

M 40/50-4+H ST3B		PRESSURE (bar)	LOAD PER TYRE (kg)			
			FRONT UNLADEN	FRONT LADEN	REAR UNLADEN	REAR LADEN
MICHELIN	18R22,5 XF TUBELESS	5,5	1700	5800		
MITAS	18-22,5 MPT-06 16PR 163A8 TUBELESS	4,5				
MICHELIN	340/80R18 XMCL 143A8 TUBELESS	3,2			2400	800

		PRESSURE (bar)	LOAD (kg)	GROUND CONTACT PRESSURE (kg/cm <sup>2</sup> )		GROUND CONTACT AREA (cm <sup>2</sup> )	
				HARD SOIL	LOOSE SOIL	HARD SOIL	LOOSE SOIL
ALLIANCE	18-19,5 A224 18PR TUBELESS	6,5					
CONTINENTAL	14,5R20 MPT80 18PR 143G/J TUBELESS	3,5	1050	1,72		613	
			3450	3,33		1031	
DUNLOP	400/70-20 T37 150B TUBELESS	2,3	1100				
			3500				
	10,5/80-18 TG42 10PR TUBELESS	3,5	750				
			1650				
GOODYEAR	10R17,5 G291 134M	5,5	700				
			1600				
MICHELIN	380/75 R20 XMCL 148A8 TUBELESS	3,5	1050				
			1100				
			3450				
			3500				
	18R19,5 XF TUBELESS	6,5					
18R22,5 XF TUBELESS	5,5	1700	1,97	0,91	844	1820	
		5800	3,68	1,70	1576	3401	
340/80R18 XMCL 143A8 TUBELESS	3,2	800					
		2400					
MITAS	18-22,5 MPT-06 16PR 163A8 TUBELESS	4,5	1700				
			5800				



		M 26-2	M 30-2
A	mm	1200	1200
B	mm	1995	1989
C	mm	747	747
D	mm	3494	3494
E	mm	4694	4694
F	mm	1550	1550
F1	mm	1644	1644
G	mm	432	432
G*	mm	381	381
G1	mm	410	400
G1*	mm	391	391
G2	mm	311	311
G2*	mm	330	330
G3	mm	375	365
H	mm	2725	2715
H1	mm	4755	4745
I	mm	758	758
J	mm	1410	1400
K	mm	1470	1470
L	mm	40	40
N	mm	1890	1880
O	mm	125	125
P1	°	60,5	60,5
P2	°	47,5	47,2
P3	°	42,2	42,2
R	mm	3300	3300
S	mm	5197	5197
T	mm	2730	2730
U	mm	2460	2450
V	mm	3490	3490
V1	mm	680	680
W	mm	1900	1900
Y	°	12	12
Z	°	6	6

G - G1 - G2 - G3 = Unladen  
 G\* - G1\* - G2\* = Rated load  
 H - H1 = Standard mast DUPLEX 3M70

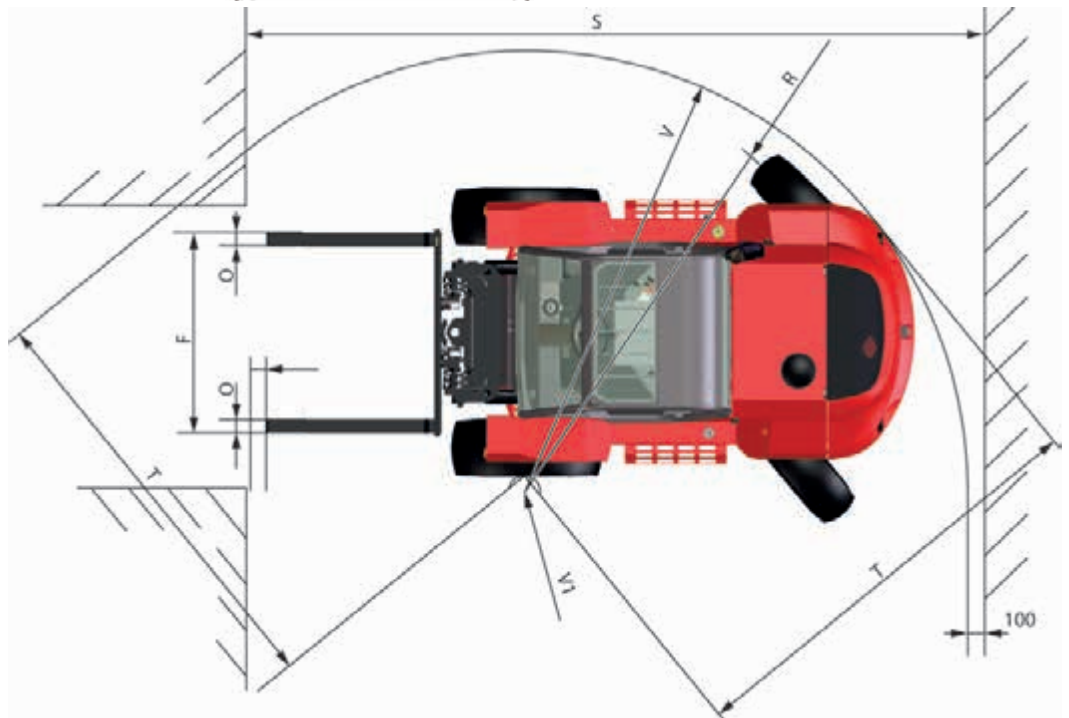
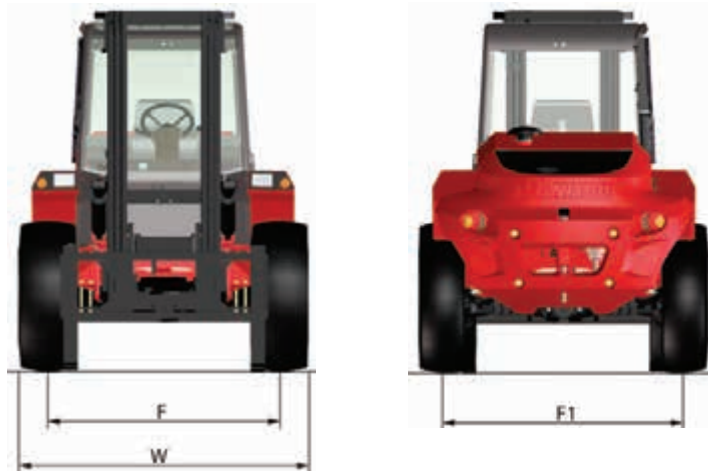
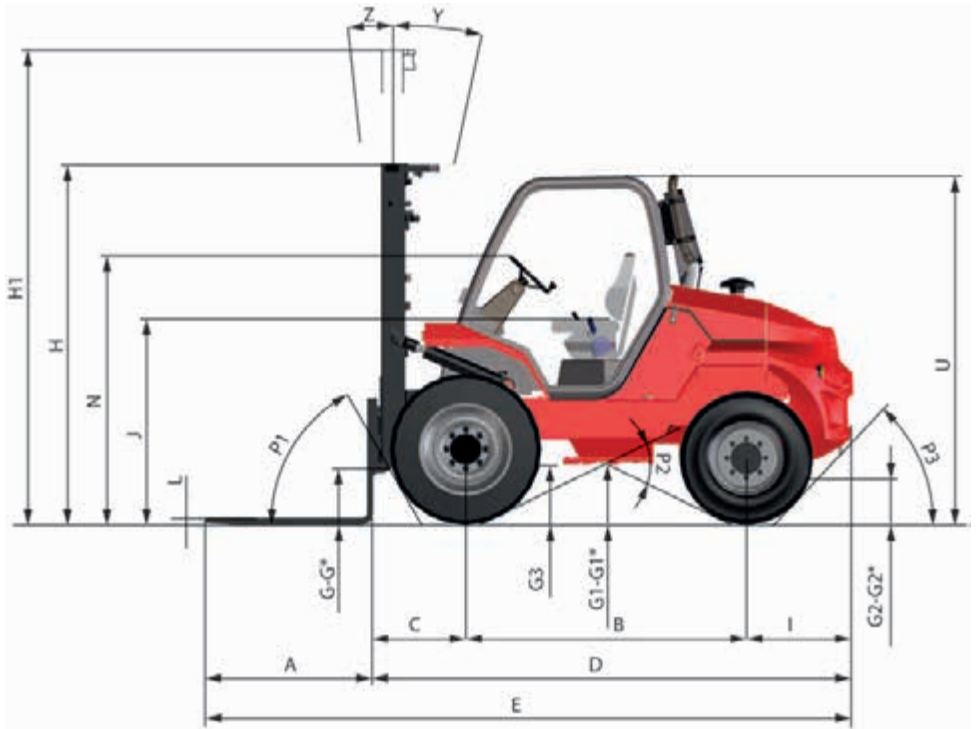

CAPACITE NOMINALE  
 RATED CAPACITY  
 NENNKAPAZITÄT  
 CAPACIDAD NOMINAL  
 CAPACITÀ NOMINALE

**2600** kg

CAPACITES EFFECTIVES  
 ACTUAL CAPACITIES  
 EFFEKTIVE KAPAZITÄT  
 CAPACIDAD EFECTIVA  
 CAPACITÀ EFFETTIVA

**SUIVANT NORME EN 1726-1**

1 - Jusqu'à hauteur de levée  
 Up to height of  
 Bis zur hubhöhe  
 Hasta altura de elevación  
 Sino ad altezza di sollevamento

-

2 - Pour hauteur maximale de  
 For maximum height of  
 Für maximale Höhe  
 Para altura máxima de  
 Per altezza massima di

**3700** mm

MAT VERTICAL  
 VERTICAL MAST  
 VERTIKALER MAST  
 MASTIL VERTICAL  
 RAMPA VERTICALE

D : mm **500 600 1100**

EQUIPEMENT  
 ATTACHMENT  
 ZUBEHÖR  
 EQUIPO  
 ATTREZZATURA

**60E-SS-B621**  
**100E-SS-B551**  
**100E-SS-B687**  
 -

CAPACITES EFFECTIVES  
 ACTUAL CAPACITIES  
 EFFEKTIVE KAPAZITÄT  
 CAPACIDAD EFECTIVA  
 CAPACITÀ EFFETTIVA

D : mm **500 600 1100**

n°: **221081**

CAPACITE NOMINALE  
 RATED CAPACITY  
 NENNKAPAZITÄT  
 CAPACIDAD NOMINAL  
 CAPACITÀ NOMINALE

**3000** kg

CAPACITES EFFECTIVES  
 ACTUAL CAPACITIES  
 EFFEKTIVE KAPAZITÄT  
 CAPACIDAD EFECTIVA  
 CAPACITÀ EFFETTIVA

**SUIVANT NORME EN 1726-1 (ISO 1074)**

1 - Jusqu'à hauteur de levée  
 Up to height of  
 Bis zur hubhöhe  
 Hasta altura de elevación  
 Sino ad altezza di sollevamento

-

2 - Pour hauteur maximale de  
 For maximum height of  
 Für maximale Höhe  
 Para altura máxima de  
 Per altezza massima di

**3700** mm

MAT VERTICAL  
 VERTICAL MAST  
 VERTIKALER MAST  
 MASTIL VERTICAL  
 RAMPA VERTICALE

D : mm **500 600 1100**

EQUIPEMENT  
 ATTACHMENT  
 ZUBEHÖR  
 EQUIPO  
 ATTREZZATURA

**60E-SS-B621**  
**100E-SS-B551**  
**100E-SS-B687**  
**100E-SS-E160**

CAPACITES EFFECTIVES  
 ACTUAL CAPACITIES  
 EFFEKTIVE KAPAZITÄT  
 CAPACIDAD EFECTIVA  
 CAPACITÀ EFFETTIVA

D : mm **500 600 1100**

n°: **218159**

		M 26-4	M 30-4
A	mm	1200	1200
B	mm	1989	1989
C	mm	747	747
D	mm	3494	3494
E	mm	4694	4694
F	mm	1520	1520
F1	mm	1630	1630
G	mm	420	420
G*	mm	415	415
G1	mm	330	320
G1*	mm	315	315
G2	mm	295	295
G2*	mm	315	310
G3	mm	385	375
H	mm	2725	2715
H1	mm	4755	4745
I	mm	758	758
J	mm	1410	1400
K	mm	1470	1470
L	mm	40	40
N	mm	1880	1880
O	mm	125	125
P1	°	60,5	60,5
P2	°	47,2	47,2
P3	°	42,2	42,2
R	mm	4300	4300
S	mm	6367	6367
T	mm	2640	2640
U	mm	2452	2452
V	mm	4270	4270
V1	mm	1630	1630
W	mm	1924	1924
Y	°	12	12
Z	°	6	6

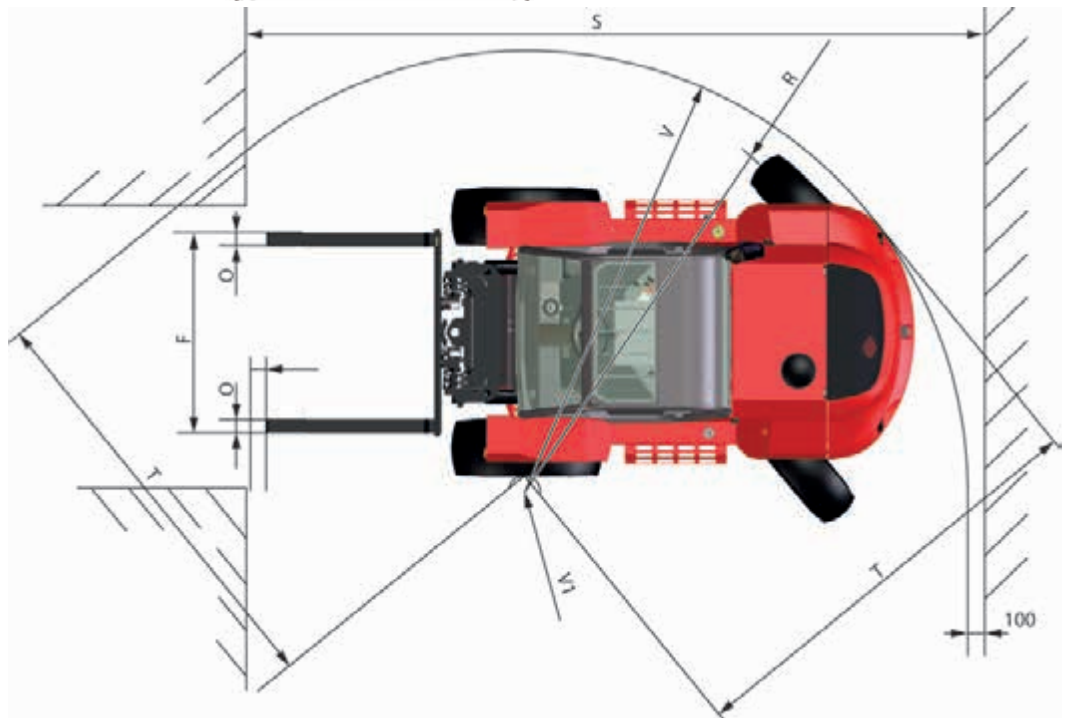
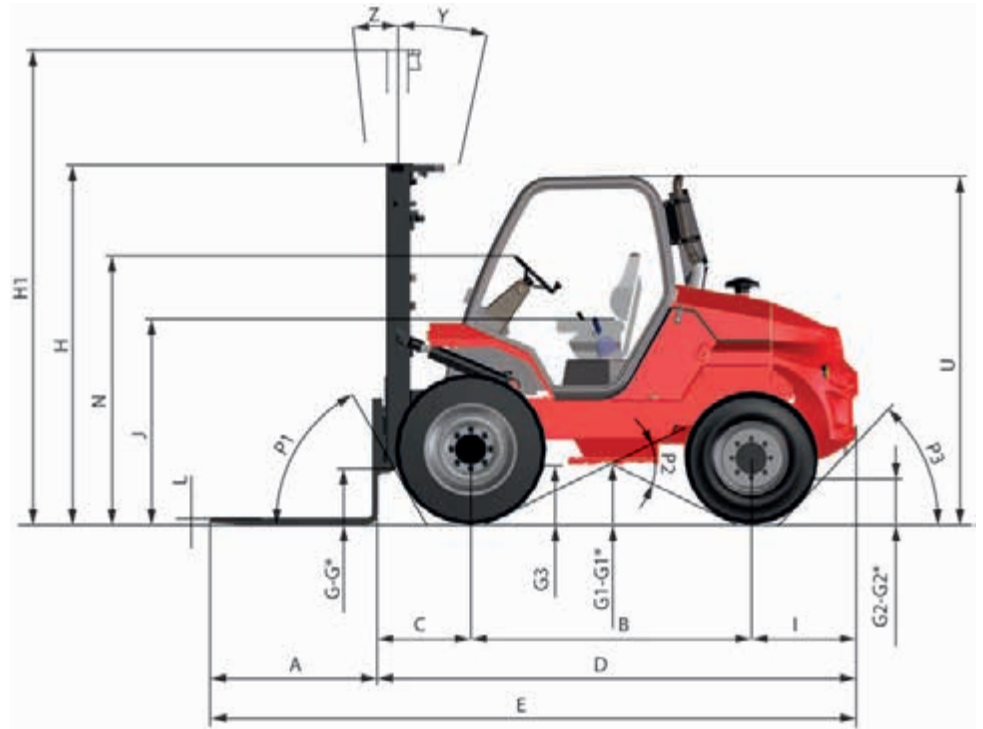

G - G1 - G2 - G3 = Unladen  
 G\* - G1\* - G2\* = Rated load  
 H - H1 = Standard mast DUPLEX 3M70

**CAPACITE NOMINALE**  
**RATED CAPACITY**  
**NENNKAPAZITÄT**  
**CAPACIDAD NOMINAL**  
**CAPACITÀ NOMINALE**

**2600** kg

**CAPACITES EFFECTIVES**  
**ACTUAL CAPACITIES**  
**EFFEKTIVE KAPAZITÄT**  
**CAPACIDAD EFECTIVA**  
**CAPACITÀ EFFETTIVA**

**SUIVANT NORME EN 1726-1**

1 - Jusqu'à hauteur de levée  
 Up to height of  
 Bis zur hubhöhe  
 Hasta altura de elevación  
 Sino ad altezza di sollevamento

2 - Pour hauteur maximale de  
 For maximum height of  
 Für maximale Höhe  
 Para altura máxima de  
 Per altezza massima di

**3700** mm

**MAT VERTICAL**  
**VERTICAL MAST**  
**VERTIKALER MAST**  
**MASTIL VERTICAL**  
**RAMPA VERTICALE**

**Q : kg**

**D : mm**

**2600** **2380** **1690**

**500** **600** **1100**

**EQUIPEMENT**  
**ATTACHMENT**  
**ZUBEHÖR**  
**EQUIPO**  
**ATTREZZATURA**

**60E-SS-B621**  
**100E-SS-B551**  
**100E-SS-B687**  
**-**

**CAPACITES EFFECTIVES**  
**ACTUAL CAPACITIES**  
**EFFEKTIVE KAPAZITÄT**  
**CAPACIDAD EFECTIVA**  
**CAPACITÀ EFFETTIVA**

1 - **2600** **2380** **1690**

2 - **2600** **2380** **1690**

n°: **221081**

**CAPACITE NOMINALE**  
**RATED CAPACITY**  
**NENNKAPAZITÄT**  
**CAPACIDAD NOMINAL**  
**CAPACITÀ NOMINALE**

**3000** kg

**CAPACITES EFFECTIVES**  
**ACTUAL CAPACITIES**  
**EFFEKTIVE KAPAZITÄT**  
**CAPACIDAD EFECTIVA**  
**CAPACITÀ EFFETTIVA**

**SUIVANT NORME EN 1726-1 (ISO 1074)**

1 - Jusqu'à hauteur de levée  
 Up to height of  
 Bis zur hubhöhe  
 Hasta altura de elevación  
 Sino ad altezza di sollevamento

2 - Pour hauteur maximale de  
 For maximum height of  
 Für maximale Höhe  
 Para altura máxima de  
 Per altezza massima di

**3700** mm

**MAT VERTICAL**  
**VERTICAL MAST**  
**VERTIKALER MAST**  
**MASTIL VERTICAL**  
**RAMPA VERTICALE**

**Q : kg**

**D : mm**

**3000** **2750** **1960**

**500** **600** **1100**

**EQUIPEMENT**  
**ATTACHMENT**  
**ZUBEHÖR**  
**EQUIPO**  
**ATTREZZATURA**

**60E-SS-B621**  
**100E-SS-B551**  
**100E-SS-B687**  
**100E-SS-E160**

**CAPACITES EFFECTIVES**  
**ACTUAL CAPACITIES**  
**EFFEKTIVE KAPAZITÄT**  
**CAPACIDAD EFECTIVA**  
**CAPACITÀ EFFETTIVA**

1 - **3000** **2750** **1960**

2 - **3000** **2750** **1960**

n°: **218159**

\* HYDROSTATIC MODELS

A	mm	1200
B	mm	2120
C	mm	762
D	mm	3741 *3640
E	mm	TBD *4291
F	mm	1620
F1	mm	1610
G	mm	335
G*	mm	280
G1	mm	345
G1*	mm	333
G2	mm	305
G2*	mm	335
G3	mm	430
H	mm	2910
H1	mm	4815
I	mm	859
J	mm	1411
K	mm	1670
L	mm	50
N	mm	1876
O	mm	150
P1	°	43,5
P2	°	55,5
P3	°	41,7
R	mm	4380
S	mm	6732
T	mm	2920
U	mm	2435
V	mm	4570 *3300
V1	mm	1650
W	mm	2080
Y	°	15
Z	°	15

G - G1 - G2 - G3 = Unladen  
 G\* - G1\* - G2\* = Rated load  
 H - H1 = Standard mast DUPLEX 3M70

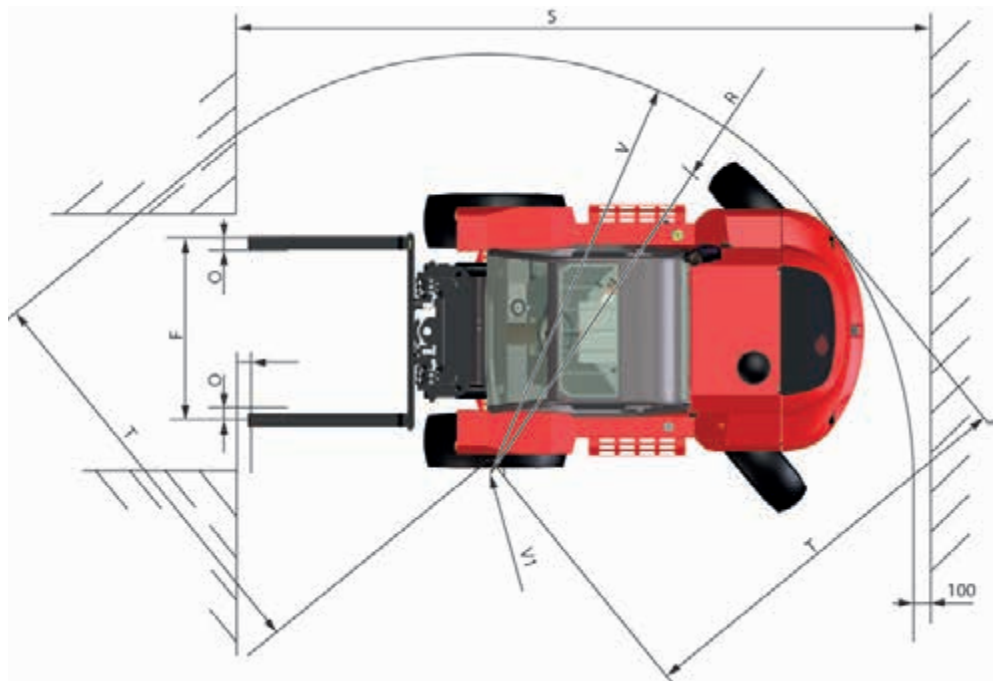
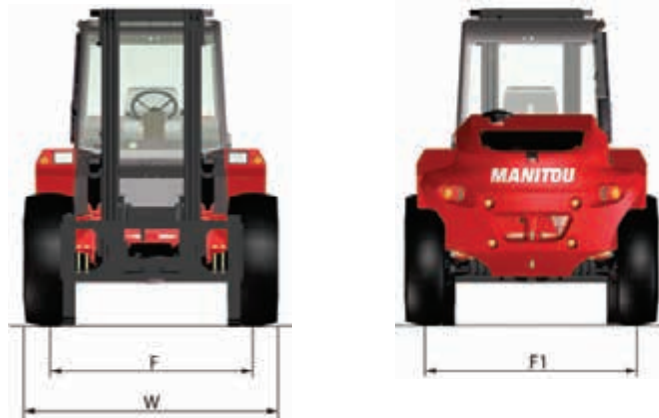
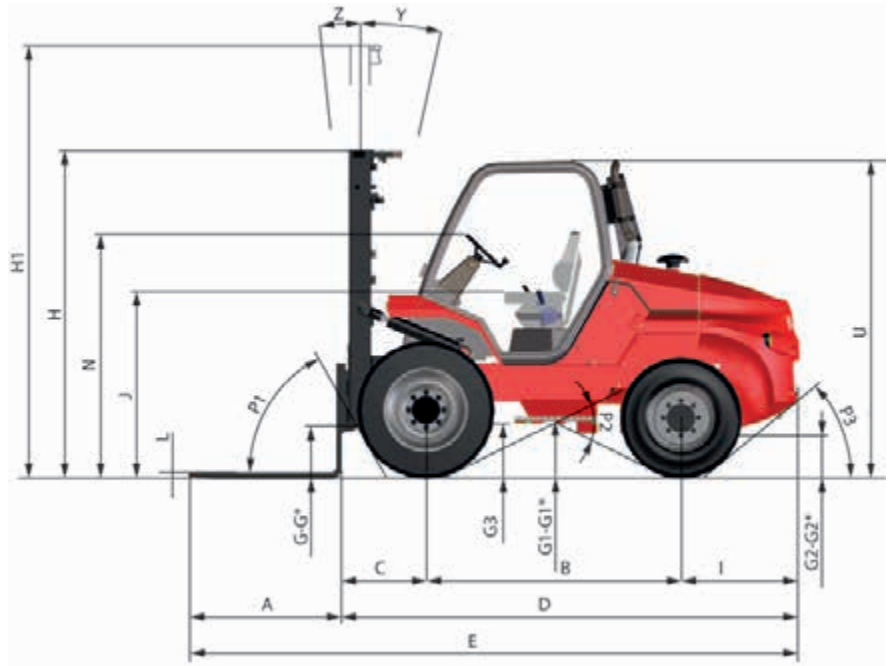

CAPACITE NOMINALE  
 RATED CAPACITY  
 NENNKAPAZITÄT  
 CAPACIDAD NOMINAL  
 CAPACITÀ NOMINALE

**4000** kg

---

CAPACITES EFFECTIVES  
 ACTUAL CAPACITIES  
 EFFEKTIVE KAPAZITÄT  
 CAPACIDAD EFECTIVA  
 CAPACITÀ EFFETTIVA

**SUIVANT NORME EN 1726-1 annexe H.**

1 - Jusqu'à hauteur de levée  
 Up to height of  
 Bis zur hubhöhe  
 Hasta altura de elevación  
 Sino ad altezza di sollevamento

- mm

2 - Pour hauteur maximale de  
 For maximum height of  
 Für maximale Höhe  
 Para altura máxima de  
 Per altezza massima di

**3700** mm

MAT VERTICAL  
 VERTICAL MAST  
 VERTIKALER MAST  
 MASTIL VERTICAL  
 RAMPÀ VERTICALE

D : mm

	<b>500</b>	<b>600</b>	<b>1200</b>
--	------------	------------	-------------

EQUIPEMENT  
 ATTACHMENT  
 ZUBEHÖR  
 EQUIPO  
 ATTREZZATURA

<b>TDLA40N 1670</b>
<b>TDLA40N 2000</b>
-
-

CAPACITES EFFECTIVES  
 ACTUAL CAPACITIES  
 EFFEKTIVE KAPAZITÄT  
 CAPACIDAD EFECTIVA  
 CAPACITÀ EFFETTIVA

1 - -  
 2 - **3600**   **3340**   **2330**

n°: 197211

### \* HYDROSTATIC MODELS

<b>A</b>	mm	1200
<b>B</b>	mm	2063
<b>C</b>	mm	772
<b>D</b>	mm	3755 *3640
<b>E</b>	mm	TBD *4291
<b>F</b>	mm	1600
<b>F1</b>	mm	1660
<b>G</b>	mm	265
<b>G*</b>	mm	210
<b>G1</b>	mm	365
<b>G1*</b>	mm	345
<b>G2</b>	mm	228
<b>G2*</b>	mm	315
<b>G3</b>	mm	360
<b>H</b>	mm	2855
<b>H1</b>	mm	4750
<b>I</b>	mm	920
<b>J</b>	mm	1380
<b>K</b>	mm	1670
<b>L</b>	mm	60
<b>N</b>	mm	1840 -1900
<b>O</b>	mm	150
<b>P1</b>	°	33,5
<b>P2</b>	°	44
<b>P3</b>	°	37
<b>R</b>	mm	2970
<b>S</b>	mm	5567
<b>T</b>	mm	3195
<b>U</b>	mm	2420
<b>V</b>	mm	3300
<b>V1</b>	mm	200
<b>W</b>	mm	2057
<b>Y</b>	°	15
<b>Z</b>	°	15

G - G1 - G2 - G3 = Unladen  
 G\* - G1\* - G2\* = Rated load  
 H - H1 = Standard mast DUPLEX 3M70

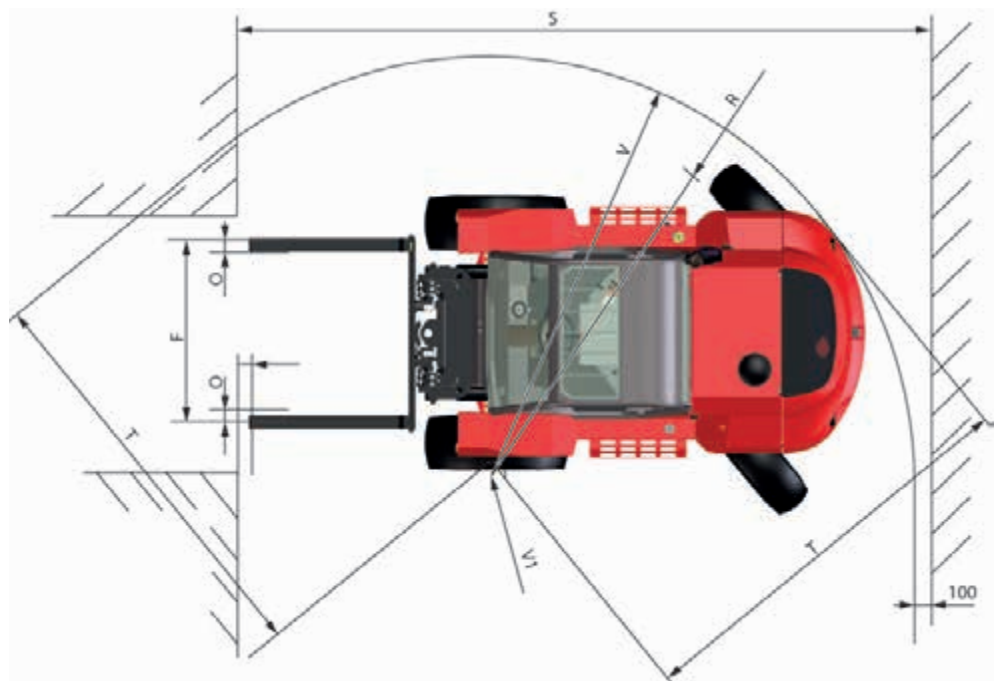
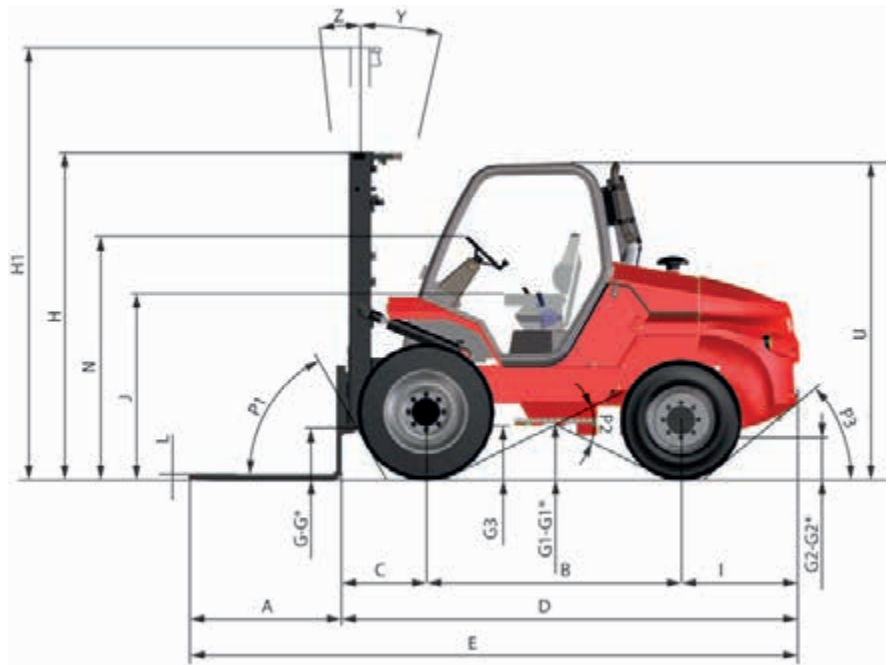

CAPACITE NOMINALE  
 RATED CAPACITY  
 NENNKAPAZITÄT  
 CAPACIDAD NOMINAL  
 CAPACITÀ NOMINALE

**4000** kg

---

CAPACITES EFFECTIVES  
 ACTUAL CAPACITIES  
 EFFEKTIVE KAPAZITÄT  
 CAPACIDAD EFECTIVA  
 CAPACITÀ EFFETTIVA

**SUIVANT NORME EN 1726-1 annexe H.**

1 - Jusqu'à hauteur de levée  
 Up to height of  
 Bis zur hubhöhe  
 Hasta altura de elevación  
 Sino ad altezza di sollevamento

- mm

2 - Pour hauteur maximale de  
 For maximum height of  
 Für maximale Höhe  
 Para altura máxima de  
 Per altezza massima di

**3700** mm

MAT VERTICAL  
 VERTICAL MAST  
 VERTIKALER MAST  
 MASTIL VERTICAL  
 RAMPÀ VERTICALE

Q : kg  
 D : mm

EQUIPEMENT	<b>TDLA40N 1670</b>
ATTACHMENT	<b>TDLA40N 2000</b>
ZUBEHÖR	-
EQUIPO	-
ATTREZZATURA	-

CAPACITES EFFECTIVES  
 ACTUAL CAPACITIES  
 EFFEKTIVE KAPAZITÄT  
 CAPACIDAD EFECTIVA  
 CAPACITÀ EFFETTIVA

1 - -  
 2 - **3600**   **3340**   **2330**

n°: **197211**

<b>A</b>	mm	1200
<b>B</b>	mm	2057
<b>C</b>	mm	766
<b>D</b>	mm	3741
<b>E</b>	mm	4941
<b>F</b>	mm	1600
<b>F1</b>	mm	1660
<b>G</b>	mm	335
<b>G*</b>	mm	210
<b>G1</b>	mm	345
<b>G1*</b>	mm	333
<b>G2</b>	mm	228
<b>G2*</b>	mm	315
<b>G3</b>	mm	360
<b>H</b>	mm	2910
<b>H1</b>	mm	4815
<b>I</b>	mm	918
<b>J</b>	mm	1411
<b>K</b>	mm	1670
<b>L</b>	mm	60
<b>N</b>	mm	1840 to 1900
<b>O</b>	mm	150
<b>P1</b>	°	43,5
<b>P2</b>	°	44
<b>P3</b>	°	37
<b>R</b>	mm	2970
<b>S</b>	mm	5567
<b>T</b>	mm	3195
<b>U</b>	mm	2435
<b>V</b>	mm	3395
<b>V1</b>	mm	200
<b>W</b>	mm	2057
<b>Y</b>	°	15
<b>Z</b>	°	15

G - G1 - G2 - G3 = Unladen  
 G\* - G1\* - G2\* = Rated load  
 H - H1 = Standard mast DUPLEX 3M70

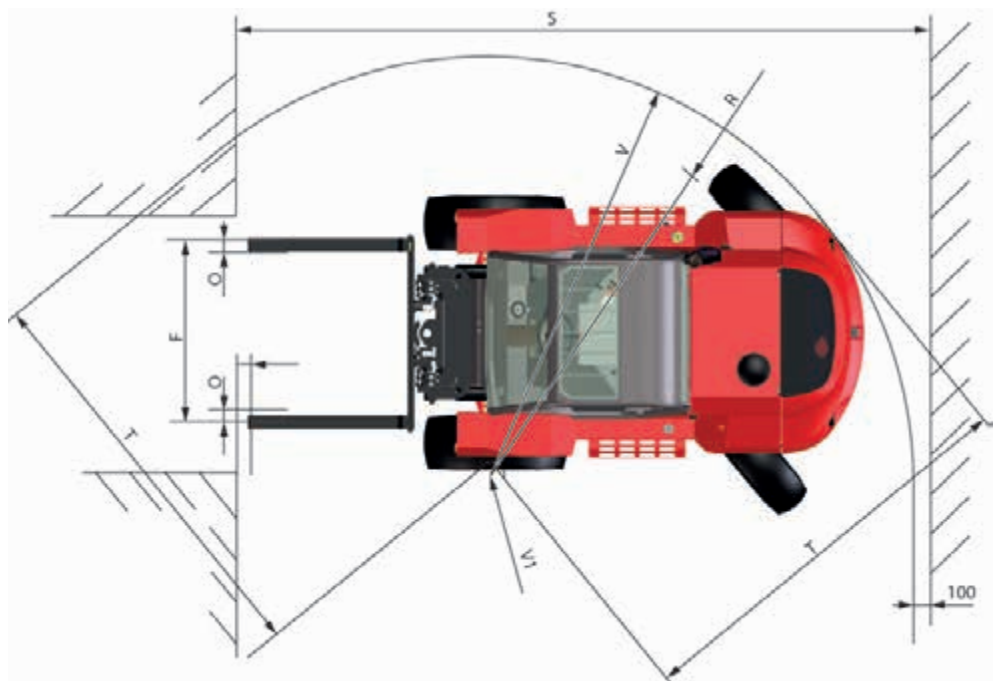
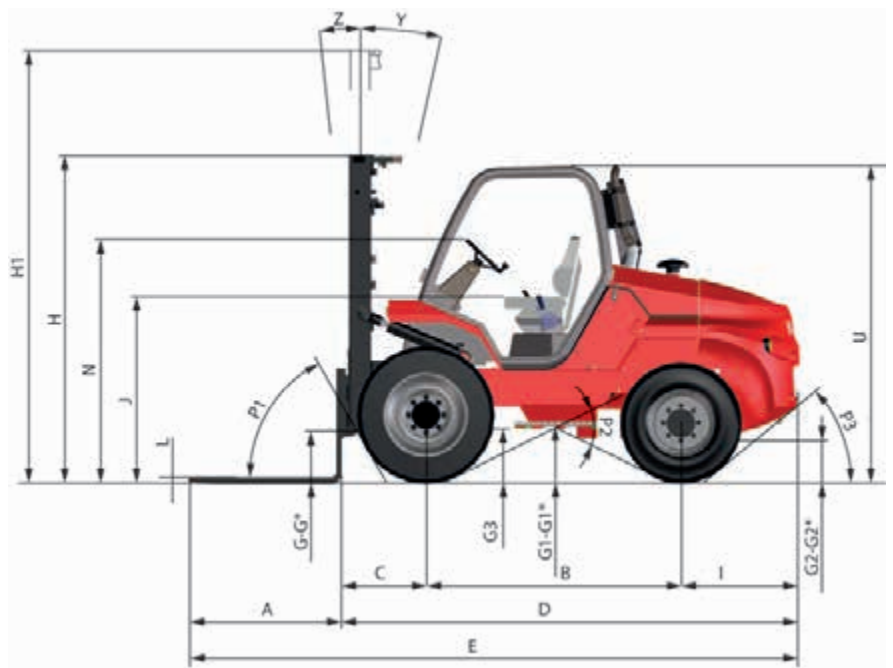

647122 (28/10/2024)  
 M26/30-2 + H ST3B / M26/30-4 + H ST3B  
 M40/50-2 + H ST3B / M40/50-4 + H ST3B

**CAPACITE NOMINALE**  
**RATED CAPACITY**  
**NENNKAPAZITÄT**  
**CAPACIDAD NOMINAL**  
**CAPACITÀ NOMINALE**

**5000** kg

---

**CAPACITES EFFECTIVES**  
**ACTUAL CAPACITIES**  
**EFFEKTIVE KAPAZITÄT**  
**CAPACIDAD EFECTIVA**  
**CAPACITÀ EFFETTIVA**

**SUIVANT NORME EN 1726-1 annexe H.**

1 - Jusqu'à hauteur de levée  
 Up to height of  
 Bis zur hubhöhe  
 Hasta altura de elevación  
 Sino ad altezza di sollevamento

- mm

2 - Pour hauteur maximale de  
 For maximum height of  
 Für maximale Höhe  
 Para altura máxima de  
 Per altezza massima di

**3700** mm

**MAT VERTICAL**  
**VERTICAL MAST**  
**VERTIKALER MAST**  
**MASTIL VERTICAL**  
**RAMPA VERTICALE**

D : mm

**600**   **1000**   **1200**

**EQUIPEMENT**  
**ATTACHMENT**  
**ZUBEHÖR**  
**EQUIPO**  
**ATTREZZATURA**

<b>TDLA50N 1670</b>
<b>TDLA50N 2000</b>
-
-

**CAPACITES EFFECTIVES**  
**ACTUAL CAPACITIES**  
**EFFEKTIVE KAPAZITÄT**  
**CAPACIDAD EFECTIVA**  
**CAPACITÀ EFFETTIVA**

1 -   -   -

**4700**   **3600**   **3200**

2 -   -   -

n°: 239178

<b>A</b>	mm	1200
<b>B</b>	mm	2120
<b>C</b>	mm	762
<b>D</b>	mm	3741
<b>E</b>	mm	4941
<b>F</b>	mm	1620
<b>F1</b>	mm	1610
<b>G</b>	mm	335
<b>G*</b>	mm	280
<b>G1</b>	mm	345
<b>G1*</b>	mm	333
<b>G2</b>	mm	305
<b>G2*</b>	mm	335
<b>G3</b>	mm	430
<b>H</b>	mm	2910
<b>H1</b>	mm	4815
<b>I</b>	mm	859
<b>J</b>	mm	1411
<b>K</b>	mm	1670
<b>L</b>	mm	50
<b>N</b>	mm	1876
<b>O</b>	mm	150
<b>P1</b>	°	43,5
<b>P2</b>	°	55,5
<b>P3</b>	°	41,7
<b>R</b>	mm	4380
<b>S</b>	mm	6732
<b>T</b>	mm	2920
<b>U</b>	mm	2435
<b>V</b>	mm	4570
<b>V1</b>	mm	1650
<b>W</b>	mm	2080
<b>Y</b>	°	15
<b>Z</b>	°	15

G - G1 - G2 - G3 = Unladen  
 G\* - G1\* - G2\* = Rated load  
 H - H1 = Standard mast DUPLEX 3M70

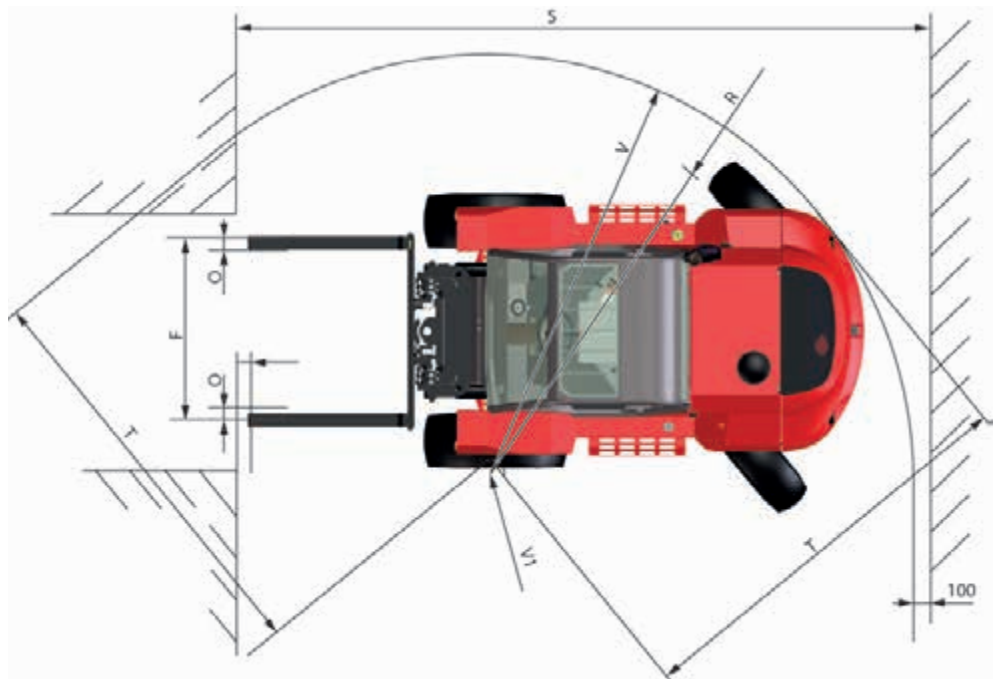
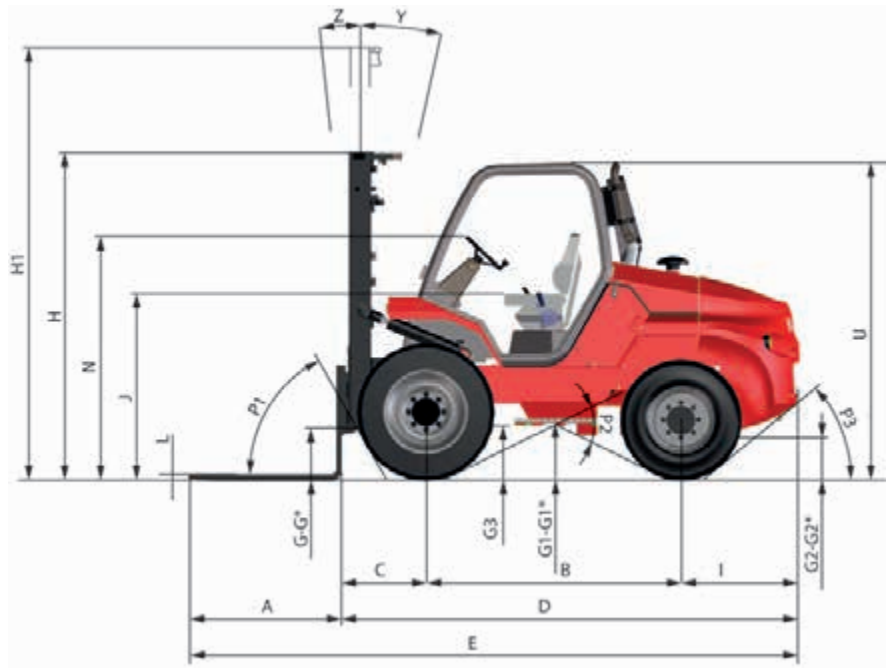

**CAPACITE NOMINALE**  
**RATED CAPACITY**  
**NENNKAPAZITÄT**  
**CAPACIDAD NOMINAL**  
**CAPACITÀ NOMINALE**

**5000** kg

---

**CAPACITES EFFECTIVES**  
**ACTUAL CAPACITIES**  
**EFFEKTIVE KAPAZITÄT**  
**CAPACIDAD EFECTIVA**  
**CAPACITÀ EFFETTIVA**

**SUIVANT NORME EN 1726-1 annexe H.**

1 - Jusqu'à hauteur de levée  
 Up to height of  
 Bis zur hubhöhe  
 Hasta altura de elevación  
 Sino ad altezza di sollevamento

- mm

2 - Pour hauteur maximale de  
 For maximum height of  
 Für maximale Höhe  
 Para altura máxima de  
 Per altezza massima di

**3700** mm

**MAT VERTICAL**  
**VERTICAL MAST**  
**VERTIKALER MAST**  
**MASTIL VERTICAL**  
**RAMPA VERTICALE**

Q : kg

D : mm

600	1000	1200
-----	------	------

Level 1 capacities: - , - , -

Level 2 capacities: **5000** , **3800** , **3400**

---

**EQUIPEMENT**  
**ATTACHMENT**  
**ZUBEHÖR**  
**EQUIPO**  
**ATTREZZATURA**

<b>TDLA50N 1670</b>		
<b>TDLA50N 2000</b>		
-		
-		

Level 1 capacities: - , - , -

Level 2 capacities: **4700** , **3600** , **3200**

n°: 239178

# INSTRUMENTS AND CONTROLS

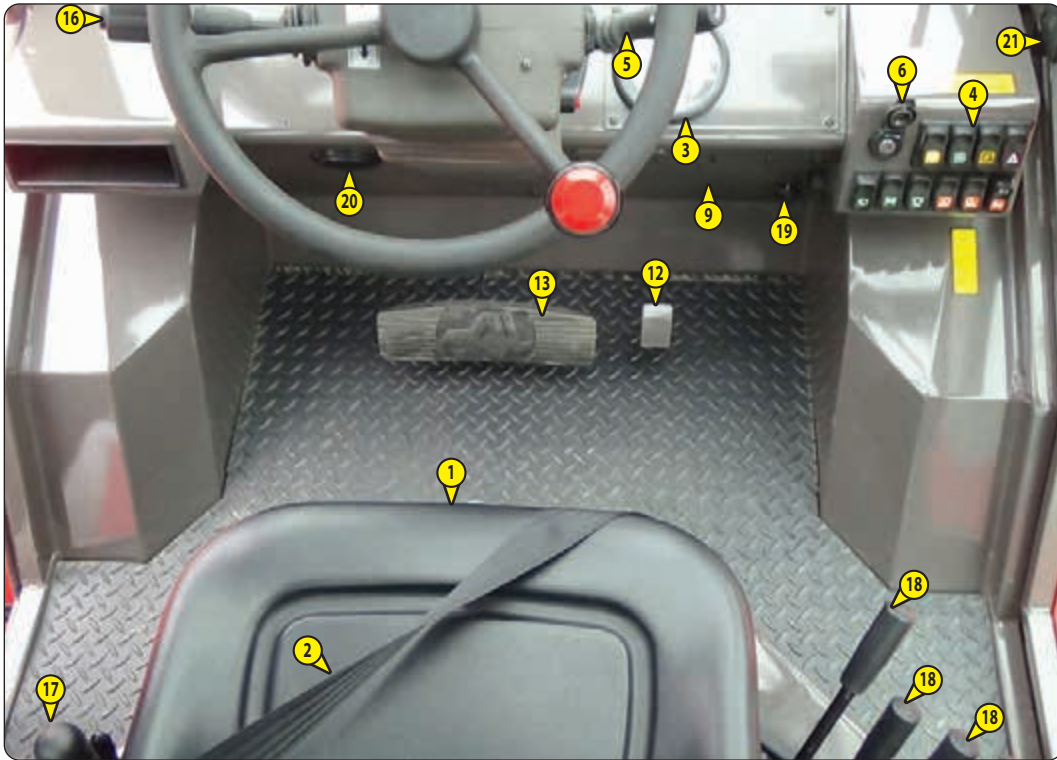



Hydrostatic Transmission Only

## DESCRIPTION

- 1 - DRIVER'S SEAT
- 2 - SEAT BELT
- 3 - CONTROL AND SIGNAL LIGHTS PANEL
- 4 - SWITCHES
- 5 - LIGHT SWITCH, HORN AND INDICATORS (OPTION)
- 6 - IGNITION SWITCH
- 7 - BRAKING OIL TANK
- 8 - WINDSCREEN WASHER TANK
- 9 - FUSES AND RELAYS IN THE CAB(NOT ILLUSTRATED)
- 10 - FUSES AND RELAYS UNDER THE ENGINE HOOD
- 11 - ROOF LIGHT (OPTION)
- 12 - ACCELERATOR PEDAL
- 13 - SERVICE BRAKE PEDAL AND TRANSMISSION CUT-OFF
- 14 - DIFFERENTIAL LOCK PUSH-BUTTON M 26/30-2+H ST3B; M 40/50-2+H ST3B
- 15 - GEAR LEVER(Torque Converter 2 and 4 Speed ONLY)
- 16 - FORWARD/NEUTRAL/REVERSE GEAR SELECTION
- 17 - PARKING BRAKE LEVER
- 18 - HYDRAULIC CONTROLS
- 19 - HEATER CONTROL (OPTION)
- 20 - HEATING VENTS (OPTION)
- 21 - DOOR LOCKS (OPTION)
- 22 - DOOR RELEASE SWITCHES (OPTION)
- 23 - DOCUMENT HOLDER NET
- 24 - FRONT LIGHTS (NOT ILLUSTRATED)
- 25 - REAR LIGHTS (NOT ILLUSTRATED)
- 26 - LEVEL INDICATOR
- 27 - BATTERY CUT-OFF
- 28 - 2 SPEED GEAR BOX SWITCH (HYDROSTATIC TRANSMISSION ONLY)

NOTE: All the terms such as: RIGHT, LEFT, FRONT, REAR are meant for an observer seated on driver's seat and looking in front of him.

## 1 - DRIVER'S SEAT

### DRIVER'S SEAT (STANDARD)

DESIGNED FOR MAXIMUM COMFORT, THIS SEAT CAN BE ADJUSTED AS FOLLOWS.

#### LONGITUDINAL ADJUSTMENT

- Pull locking lever 1 Up.
- Slide the seat to the desired position.
- Release the lever and be sure it returns to the lock position.



#### SEAT SUSPENSION ADJUSTMENT

- Refer to graduation of the seat.
- Turn Knob 2 to the Left or Right to adjust to the Driver's Weight.

#### SEAT SUSPENSION ADJUSTMENT

- Refer to graduation of the seat.
- Turn Knob 3 to the Left or Right to adjust to the Driver's Height.



#### ANGLE ADJUSTMENT OF THE BACK-REST

- Turn Knob 4 Forward or Backward.
- Push the back-rest to the required position.



### DRIVER'S SEAT (OPTION)

DESIGNED FOR MAXIMUM COMFORT, THIS SEAT CAN BE ADJUSTED AS FOLLOWS.

#### LONGITUDINAL ADJUSTMENT

- Pull the locking lever 1 upwards.
- Slide the seat to the desired position.
- Release the lever and be sure it returns to the lock position.

#### SEAT SUSPENSION ADJUSTMENT

- Pull and lift up the locking lever 2 so as to place it into one of these five positions.
  - Position A: Light-weight driver (50 kg).
  - Position B: Intermediate.
  - Position C: Middle-weight driver.
  - Position D: Intermediate.
  - Position E: Heavy-weight driver (120 kg).

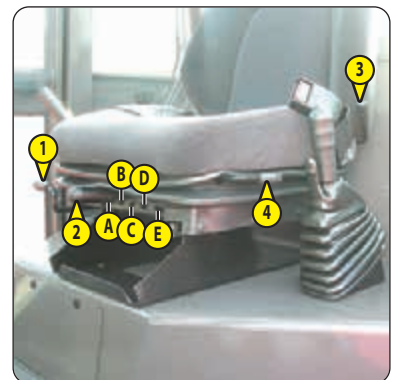

#### ANGLE ADJUSTMENT OF THE BACK-REST

- Pull the locking lever 3 backwards.
- Tilt the back-rest into one of the three possible positions.
- Release the lever and be sure it returns to the lock position.

#### ANGLE ADJUSTMENT OF THE WHOLE SEAT

- Lift up the locking lever 4.
- Tilt the seat forwards or backwards.
- Release the lever and ensure it returns to the lock position.

## PNEUMATIC DRIVER'S SEAT (OPTION)

DESIGNED FOR MAXIMUM COMFORT, THIS SEAT CAN BE ADJUSTED AS FOLLOWS.

### WEIGHT AND SEAT HEIGHT ADJUSTMENT

#### WEIGHT ADJUSTMENT (FIG. A)

It is advised that you adjust the seat according to your weight when sitting.

- Switch on lift truck ignition.
- Push or pull lever 1 until green appears in display 2 indicating correct adjustment according to your weight.

NOTE: To avoid any health problems, it is recommended that the weight should be checked and adjusted before starting up the lift truck.

#### SEAT HEIGHT ADJUSTMENT (FIG. B)

### **⚠ IMPORTANT ⚠**

*To avoid causing any damage, do not activate the compressor for over 1 minute.*

When weight adjustment has been carried out, you can then modify seat height.

- Keep the ignition on in the lift truck.
- Push or pull lever 1 until green appears and adjust the height of the seat while checking that the green in display 2 remains visible.

#### SEAT BACK-REST ANGLE ADJUSTMENT (FIG. C)

The back-rest angle of the seat may be adjusted to suit the individual.

- Press the left-hand button while pushing on the seat or relaxing pressure on the seat to find a comfortable position.

#### SEAT DEPTH ADJUSTMENT (FIG. D)

The depth of the seat may be adjusted to suit the individual.

- Press the right-hand button while raising or lowering the seat to find the desired position.

#### EXTENDING THE HEAD-REST (FIG. E)

- The height of the head-rest can be adjusted by pulling it upwards (the notches will click) up to the stop.
- The head-rest can be removed by applying sufficient pressure to pull it off the stop.

#### LUMBAR ADJUSTMENT (FIG. F)

This increases the comfort of the seat and the driver's freedom of movement.

- Turn the handle either left or right to adjust the height or depth of the lumbar support.

#### ADJUSTMENT OF THE ANGLE OF THE BACK-REST (FIG. G)

### **⚠ IMPORTANT ⚠**

*If you do not support the back-rest when making adjustments, it swings completely forwards.*

- Support the back-rest, pull the lever and position the back-rest to find the desired position.

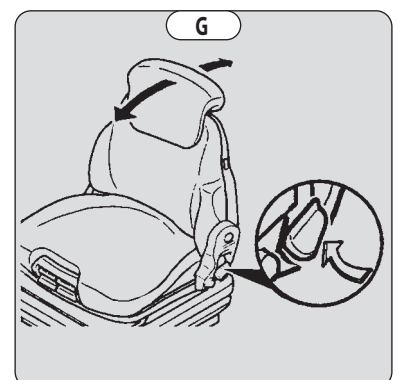
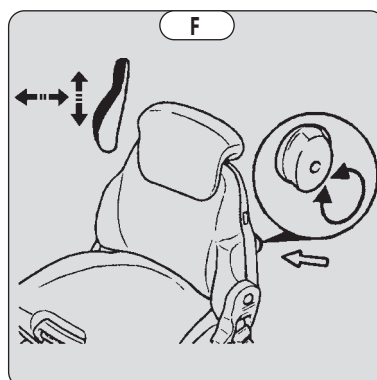
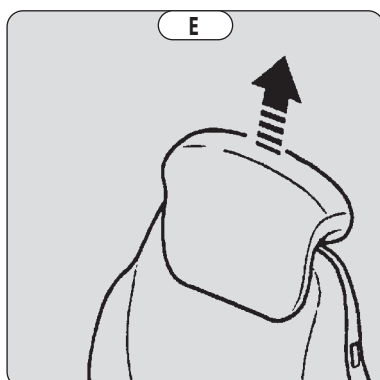
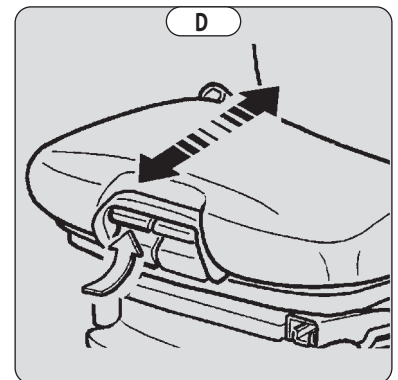
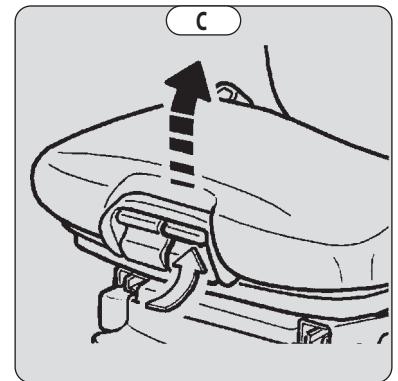
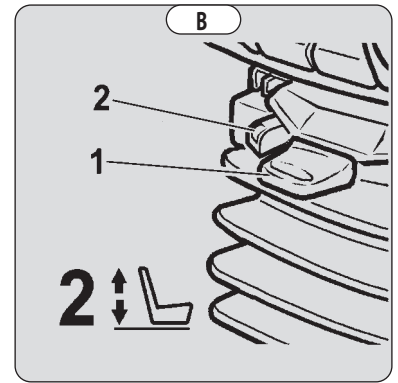
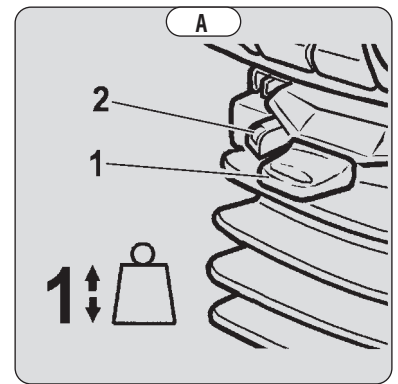

## HORIZONTAL SHOCK ABSORBER (FIG. H)

In certain conditions (e.g. driving with a trailer) it is advised that a horizontal shock absorber be used. The driver's seat is thus better able to absorb jerks in the direction of travel.

- Position 1: Horizontal shock absorber fitted.
- Position 2: Horizontal shock absorber removed.

## LONGITUDINAL ADJUSTMENT (FIG. I)

- Adjust the locking lever until you reach the position required. This then locks and the seat will not shift into another position.

## SERVICING (FIG. J)

### **⚠ IMPORTANT ⚠**

*A rocking head-rest increases the risk of an accident!*

Dirt may adversely affect the correct functioning of the seat. For this reason, make sure your seat is always clean.

- To clean or change the cushions, simply remove them from the seat frame.
- Avoid wetting the cushion fabric when cleaning. Check the resistance of the fabric on a small hidden area before using any fabric or plastic cleaner.

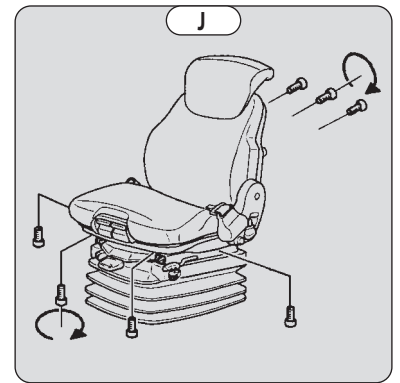
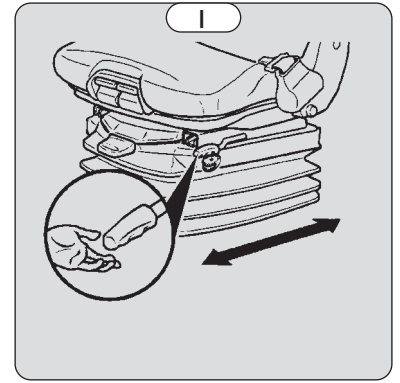
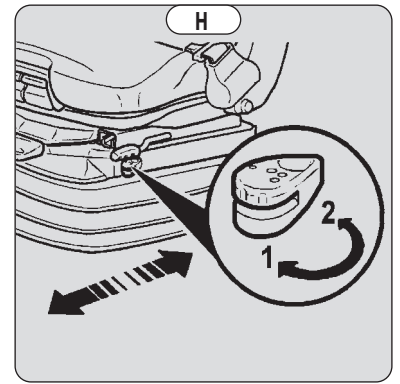

## 2 - SEAT BELT

### **⚠ IMPORTANT ⚠**

*In no event should the lift truck be used if the seat belt is defective (fixing, locking, cuts, tears, etc.).*

*Repair or replace the seat belt immediately.*

- Sit correctly on the seat.
- Check that seat belt is not twisted.
- Place the seat belt at hip level.
- Attach the seat belt and check that it locks.
- Adjust the seat belt to your body shape without squeezing your hip and without over-slack.

### 3 - CONTROL AND SIGNAL LIGHTS PANEL

#### SIGNAL LIGHTS

When activating the electrical system of the lift truck, all the red lamps and the panel's buzzer must light to indicate their good working order. If one of the red lamps or the buzzer does not function, carry out the necessary repairs.

#### A - HOURMETER

#### B - REV COUNTER

#### C - FUEL LEVEL

The yellow indicator lamp C1 is lit to indicate that you are using the reserve supply and that time of use is limited.

#### D - FORWARD/REVERSE LIGHT

See: 2 - DESCRIPTION: 16 - FORWARD/NEUTRAL/REVERSE GEAR SELECTION.

#### E - GREEN STEERING LIGHTS

A continuous beeping sound on and off at the same time as the steering lights when using flashing lights or hazard warning lights.

#### F - I.C. ENGINE WATER LEVEL AND TEMPERATURE LAMP

**COLD ENGINE:** If the lamp F1 comes on when the lift truck is running, this means that the coolant level is too low. Immediately stop the I.C. engine and check the coolant level.

**HOT ENGINE:** If lamp F1 comes on when the lift truck is running, this means that the cooling liquid temperature is too high or its level is too low. Immediately stop the I.C. engine and seek the cause of the cooling system malfunction.

#### PARKING BRAKE LAMP

This lamp comes on when the parking brake is applied.

#### BLUE MAIN BEAM LAMP

#### HYDRAULIC RETURN OIL FILTER CARTRIDGE CLOGGING LAMP

The lamp comes on when the hydraulic return oil filter cartridge is clogged up. When this lamp remains continuously lit the cartridge needs changing. Stop the lift truck and carry out the necessary repairs (see: 3 - MAINTENANCE: SERVICING SCHEDULE).

**NOTE:** This lamp comes on by cold weather or when starting the fork lift truck, it goes off when the hydraulic oil reaches its operating temperature.

#### BRAKE FLUID LEVEL OR POWER-ASSISTED BRAKING FAULT INDICATOR LAMP

If the lamp comes on, when the lift truck is running, stop the I.C. engine immediately and check the braking oil level. In the event of an abnormal drop in the level, consult your dealer.

#### TRANSMISSION OIL TEMPERATURE INDICATOR LIGHT

The lamp comes on while the lift truck is running to indicate that the transmission oil temperature is too high. Stop the lift truck and look for the cause (ex. Oil level is too low, internal leak etc.)

#### GEAR BOX OIL PRESSURE LAMP

This lamp comes on when there is an abnormal drop in gear box pressure. Stop the lift truck and look for the cause (e.g., Low oil level in the transmission, internal leak in the transmission, etc.).

#### BATTERY LOAD LAMP

If this lamp comes on when the lift truck is running, switch off the I.C engine immediately and check the electric circuit and the alternator belt.

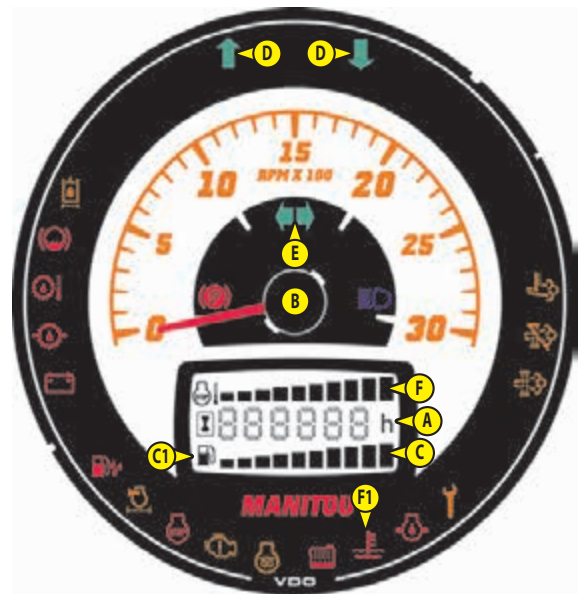



### WATER IN FUEL PRE-FILTER LAMP

This lamp will come on when there is water in the fuel pre-filter. Stop the lift truck and carry out the necessary repairs (see: 3 - MAINTENANCE: SERVICING SCHEDULE).



### AIR FILTER CLOGGING LAMP

The lamp comes on when the air filter cartridge is clogged up. When this lamp remains continuously lit the cartridge needs changing. Stop the lift truck and carry out the necessary repairs (see: 3 - MAINTENANCE: SERVICING SCHEDULE).



### I.C. CUT-OFF ENGINE LAMP

If the lamp comes on when the lift truck is running, stop the I.C. engine and look for the cause (request for regeneration of the exhaust particle filter "stationary lift truck").

NOTE: This lamp comes on the moment the ignition key is in position I and until the engine is started.



### I.C. ENGINE PREHEATING FAULT INDICATOR LAMP

If the lamp comes on when the lift truck is running, stop the I.C. engine and look for the cause (possible leak, request for regeneration of the exhaust particle filter "stationary lift truck" etc.).



### I.C. ENGINE AUTOMATIC PRE-HEATING LAMP

This lamp comes on when the lift truck's ignition is switched on and should go out as soon as pre-heating is ended. If it comes on while the lift truck is in operation, immediately stop the I.C. engine and find the cause.



### COOLING LIQUID LEVEL LAMP

The lamp comes on while the lift truck is running to indicate the cooling liquid level is too low.



### ENGINE COOLING LIQUID TEMPERATURE LAMP

This lamp will come on when the temperature of the engine cooling liquid is too high. Stop the lift truck and carry out the necessary repairs (see: 3 - MAINTENANCE: SERVICING SCHEDULE).



### I.C. ENGINE OIL PRESSURE LAMP

If the lamp comes on when the lift truck is running, stop the I.C. engine immediately and look for the cause (see oil level in I.C. engine crankcase).



### I.C. ENGINE OIL CHANGE LAMP

The lamp comes on at 450 hours in order to alert the operator to change the engine oil at 500 hours. If the lamp comes before the 500 hour maintenance, replace the engine oil. This is due to a large number of automatic exhaust particle filter regenerations and "stationary lift truck" exhaust particle filter regenerations.

## RESETTING THE MAINTENANCE LIGHT ON MACHINE.

To reset the maintenance light for the next 500 hours, proceed as follow:

- Fully depress the accelerator pedal and turn key On, hold pedal down for 17 seconds.
- Release the pedal and wait 17 seconds.
- Fully depress the accelerator pedal for 17 seconds
- Release the Pedal and wait 17 seconds.
- Depress the accelerator pedal half way for 17 seconds.
- Turn Key Off.

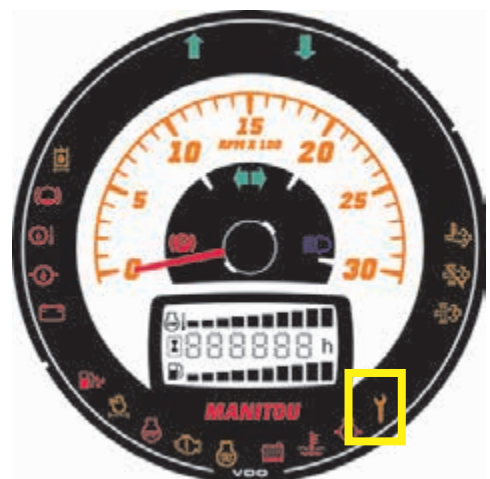

## EXHAUST PARTICLE FILTER ACTIVATED LAMP

The lamp comes on while the lift truck is running to indicate an automatic regeneration of the exhaust particle filter.

## EXHAUST PARTICLE FILTER DEACTIVATED LAMP

The lamp comes on when the lift truck is running to indicate the deactivation of the automatic regeneration of the exhaust particle filter.

## HIGH EXHAUST GAS TEMPERATURE INDICATOR LAMP

The lamp comes on while the lift truck is running to indicate a high exhaust gas temperature.

## 4 - SWITCHES

NOTE: The location of the switches may vary depending on the options. For the Hydrostatic Switches see #28.

### A - FRONT WINDSCREEN WIPER AND WINDSCREEN WASHER

This switch, when set to the "intermediate" position, the windscreen wiper to be operated and the "down" position and simultaneously pressed, the windscreen washer to be operated.

### B - HEATING FAN

This two speed switch allows warm or cold air to pass through the heating ventilators.

### C - TRANSMISSION CUT-OFF

The switch selects transmission cut-off to the service brake pedal.

- Position 1: Indicator light on, transmission cut-off to service brake pedal effected.
- Position 2: Indicator light off, transmission cut-off to service brake pedal not effected.

NOTE: In all cases transmission cut-off can be effected using the gear lever.

### D - WARNING LIGHTS

This switch enables the L.H. and R.H. indicators to be switched on simultaneously, with the ignition off. The signal light indicates that the switch is being used.

### E - REAR WINDSCREEN WIPER + OPTIONAL ROOF WINDSCREEN WIPER

### F - REAR AXLE CLUTCH (TORQUE CONVERTER ONLY)

M 26/30-4+ ST3B

M 40/50-4+ ST3B

This switch allows the lift truck to be used in two- or four-wheel drive mode. Only use the rear axle clutch switch from a stationary position and never do so abruptly.

- 2-Wheel drive: Switch in position 1 indicator light off.
- 4-Wheel drive: Switch in position 2 indicator light on.

NOTE: 4 WD Hydrostatic models are full time 4 WD

### G - ROTATING BEACON LIGHT OPTION

### H - FRONT WORK LIGHT OPTION

### I - REAR WORK LIGHT OPTION

### J - EXHAUST PARTICLE FILTER REGENERATION



- J1: DISABLE AUTOMATIC REGENERATION
- J2: "STATIONARY LIFT TRUCK" REGENERATION (See: 3 - MAINTENANCE: H2 - "STATIONARY LIFT TRUCK" EXHAUST PARTICLE FILTER)

J1: DISABLE AUTOMATIC REGENERATION













## IMPORTANT

*Disabling automatic regeneration of the exhaust particle filter is a function that is only to be used in case of necessity (confined or unventilated space, etc.).*

By default, exhaust particle filter automatic regeneration is enabled each time the lift truck is started.

- To disable automatic regeneration of the exhaust particle filter, hold down the bottom of the switch. The lamp turns on  and confirms that it has been disabled.
- To re-enable automatic regeneration of the exhaust particle filter, hold down the bottom of the switch again. The lamp turns off  and confirms that it has been re-enabled.



MANAGEMENT OF EXHAUST PARTICLE FILTER REGENERATION	
INDICATIONS	ACTIONS
 + 2 short beeps. Moderate soot level.	The lamp turns on  and the idling speed increases to indicate that automatic regeneration is in progress. NOTE: Preferably wait until automatic regeneration is completed before switching off the ignition.
 +  + 1 short beep. Moderate soot level, automatic regeneration disabled.	Enable automatic regeneration at the earliest possible time.
 +  + 1 long beep. High soot level.	Reduced lift truck efficiency, only "stationary lift truck" regeneration can be performed (see: 3 - MAINTENANCE: OCCASIONAL MAINTENANCE).
 +  +  + 1 long beep. High soot level, automatic regeneration disabled.	
 +  +  + 1 short beep. Very high soot level, particle filter clogged.	<b>Reduced lift truck efficiency, shut down the lift truck and contact your dealer.</b>

## 5 - LIGHTING, HORN AND INDICATOR SWITCH

The switch controls the visual and sound alarms.

- A - All lights are off, the direction indicators do not flash.
- B - The right-hand direction indicators flash.
- C - The left-hand direction indicators flash.
- D - The sidelights and the rear lights are on.
- E - The dipped headlights and the rear lights are on.
- F - The main beam headlights and the rear lights are on.
- G - Headlight signal.

Pressing the switch sounds the horn.

NOTE: The positions D - E - F - G can be carried out without the ignition being on.

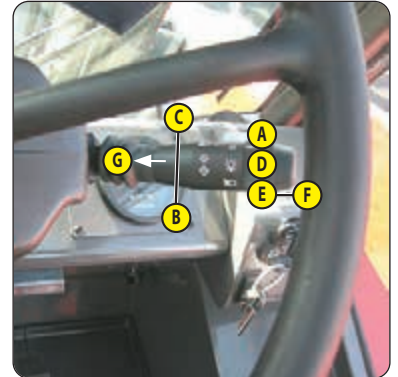

## 6 - IGNITION SWITCH

The ignition switch has five positions:

- P - Not used.
- O - Ignition switched off and engine stopped.
- I - Ignition + preheating.
- II - Not used.
- III - The engine starts, return to position I as soon as the key is released.

## 7 - BRAKING OIL TANK

See: 3 - MAINTENANCE: B - EVERY 50 HOURS SERVICE.

## 8 - WINDSCREEN WASHER TANK

See: 3 - MAINTENANCE: B - EVERY 50 HOURS SERVICE.

## 9 - FUSES AND RELAYS IN THE CAB

- Remove access panel 1 to gain access to the fuses and relays, Replace a used fuse with a new fuse of the same quality and capacity. Never reuse a repaired fuse.

### FUSES

- F1 - OPTION Front working lights (15A).
- F2 - OPTION Rear working lights (15A).
- F3 - Rear axle clutch (10A) M 30-4+H ST3B M 50-4+H ST3B
- F4 - OPTION Rotating beacon light (7,5A).
- F5 - OPTION Car radio (7,5A).  
OPTIONAL Pneumatic seat (15A).  
OPTION Car radio + OPTION Pneumatic seat (15A).
- F6 - OPTION Immobiliser (3A).
- F7 - Diagnostic plug (5A).
- F8 - Control instrument module + buzzer (5A).
- F9 - Rear windscreen wiper + windscreen washer (7,5A).



- OPTION Roof windscreen wiper (15A).
- F10 - Front windscreen wiper + windscreen washer (15A).
- F11 - Engine control until + particle filter regeneration switch (5A).
- F12 - "Driver presence safety" power supply relay (10A).  
OPTION Air conditioning relay (10A).
- F13 - OPTION Engine oil vapour reheater (3A).
- F14 - Free.
- F15 - Sound alarm + stop switch (10A).
- F16 - Free.
- F17 - Seat contact + hand brake + transmission cut-off switch indicator lamp (5A).
- F18 - Flashing unit (10A).
- F19 - Forward/neutral/reverse selector (10A).  
OPTION Reverse buzzer alarm (10A).
- F20 - Ventilation/heating (15A).
- F21 - Lights, horn and indicator switch (20A).
- F22 - Windscreen wiper engine automatic return (15A).
- F23 - Roof light (3A).
- F24 - Control instrument module (3A).
- F25 - Free.
- F26 - OPTION Car radio (5A).
- F27 - OPTION Immobiliser (3A).
- F28 - Diagnostic plug (5A).
- F29 - "Driver presence safety" module (15A).
- F30 - Hazard warning light switch (15A)
- F31 - Right sidelight + control panel (3A).
- F32 - Left sidelights (3A).
- F33 - Right indicator + OPTION air conditioning panel (7,5A).
- F34 - Left indicator (7,5A).
- F35 - Low beam (15A).
- F36 - Main beam + lamp (15A).
- F37 - Free.
- F38 - Free.
- F39 - Free.
- F40 - Free.

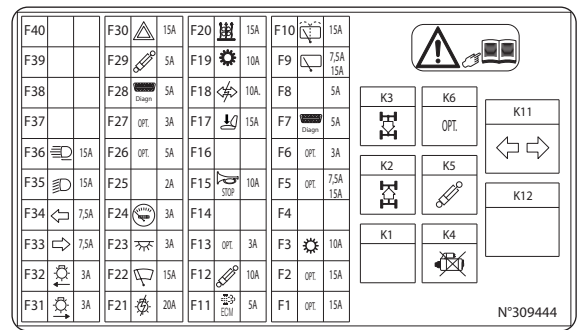

**RELAY**

- K1 - "Driver presence safety" relay.
- K2 - Forward gear relay.
- K3 - Reverse gear relay.
- K4 - Neutral ignition safety.
- K5 - "Driver presence safety" relay.
- K6 - OPTION Air conditioning relay.
- K11 - Flashing unit.
- K12 - OPTION.

**10 - FUSES AND RELAYS UNDER THE ENGINE HOOD**

- Open engine hood, remove the cover 1 in order to gain access to the fuses and relays. Replace a used fuse with a new fuse of the same quality and capacity. Never reuse a repaired fuse.

**FUSES**

- F41 - Engine computer power supply (25A).
- F42 - Engine computer power supply (5A).
- F43 - Lambda sensor + diagnostic plug (5A).
- F44 - Engine computer relay control (5A).
- F45 - Starting control relay K22 (30A).
- F46 - Free.
- F47 - Engine computer power supply (40A).
- F48 - Engine Preheat Module (60A).
- F49 - Ignition switch (80A).

**RELAY**

- K21 - Engine computer power relay.
- K22 - Start control relay.

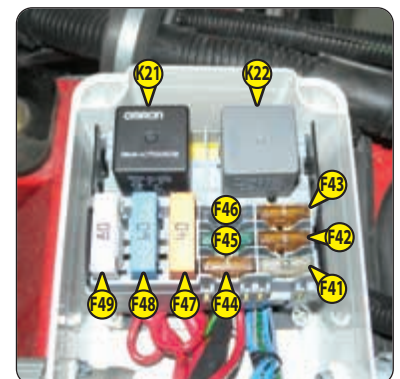
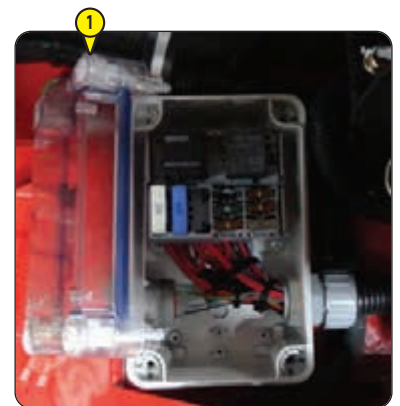

647122 (28/10/2024)  
 M26/30-2 + H ST3B / M26/30-4 + H ST3B  
 M40/50-2 + H ST3B / M40/50-4 + H ST3B

## 11 - CEILING LIGHT

## 12 - ACCELERATOR PEDAL

## 13 - SERVICE BRAKE PEDAL AND TRANSMISSION CUT-OFF

The pedal applies on the front wheels by an hydraulic brake system, and allows the lift truck to be slowed down and stopped. Depending on the position of the transmission cut-off switch, it enables the free travel to cut off transmission (see: 2 - DESCRIPTION: 4 - SWITCHES).

## 14 - DIFFERENTIAL LOCK PUSH-BUTTON

M 30-2+H ST3B; M 50-2+H ST3B

### ⚠ IMPORTANT ⚠

*While the differential lock is engaged, always drive in a straight line and remain in first gear.*

The differential lock allows the driving wheels to rotate at the same speed regardless of ground conditions. Press on the top of the push-button to engage.

- Hold this position for as long as the differential lock is required. To disengage, simply remove the foot from the push-button that will automatically return to its initial position.



## 15 - GEAR LEVER

In order to change gear, it is necessary to cut the transmission by pressing button 1 on the lever.

- 1st gear: To the right, backwards.
- 2nd gear: To the right, forwards.
- 3rd gear: To the left, backwards.
- 4th gear: To the left, forwards.

### CONDITION FOR USING THE TRANSMISSION GEAR RATIOS

NOTE: On these lift trucks with a torque converter, it is not necessary to automatically start up in 1st gear and progress up the gears.

### ⚠ IMPORTANT ⚠

*Progressing up the gears should be made carefully in relation to the work to be performed.*

*A bad gear choice may lead to an extremely rapid temperature rise of the gear box oil by excessive slipping of the converter, which can lead to severe damage (it is important to stop and change the working conditions if the gear box oil temperature indicator light turns on).*

*This bad choice may also lead to a decrease in the lift truck's performance in forward speed. When the forward effort increases, the moving speed in the gear (for example 3rd gear) may be weaker than the forward speed that can be obtained in 1st gear (in 2nd gear instead of 3rd).*

In general, we would advise you to use the following gears according to the nature of the work being carried out.

- On the road, set off in 3rd gear and go into 4th when the conditions and state of the road allow. In hilly areas, set off in 2nd gear and go into 3rd when the conditions and the state of the road allow.
- With a trailer on the road: set off in 2nd gear and switch to 3rd if the conditions and the state of the road allows.
- Handling: 3rd gear.  
2nd gear in restricted spaces.
- Earth moving: 1st gear.
- Loading (picking up with bucket, manure fork, etc.): 2nd gear.

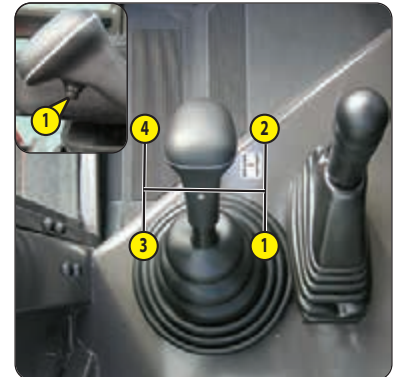

## 16 - FORWARD/NEUTRAL/REVERSE GEAR SELECTION

When operating this control, the lift truck should be travelling at slow speed and not accelerating. When the reverser is in the neutral position a mechanical lock prevents an accidental shifting movement.

- FORWARD: Lift slightly and push the lever forwards (position A).
- REVERSE: Lift slightly and pull the lever backwards (position B).
- NEUTRAL: To start the lift truck, the lever must be in neutral (position C).

NOTE: As an OPTION, reversing lights and an acoustic reversing alarm indicate that the lift truck is running in reverse.

### SAFETY FOR MOVING THE LIFT TRUCK

- Authorisation to move the lift truck is controlled by an electronic unit. The operator must observe the following sequence to move the truck forwards or backwards:
  - 1 - sit down correctly in the driver's seat,
  - 2 - release the parking brake,
  - 3 - engage forward or reverse movement.
- To stop the lift truck, he must observe the following sequence:
  - 1 - set the forward/reverse selector to neutral,
  - 2 - engage the parking brake,
  - 3 - get out of the lift truck.

NOTE: If the operator leaves the driving cab with forward or reverse engaged, a continuous alarm will sound. While this alarm sounds, the operator can simply sit back in the seat and continue advancing or reversing. If the alarm becomes discontinuous, the operator must sit back in the seat, put the selector back in neutral and select forward or reverse if he wishes to continue moving.

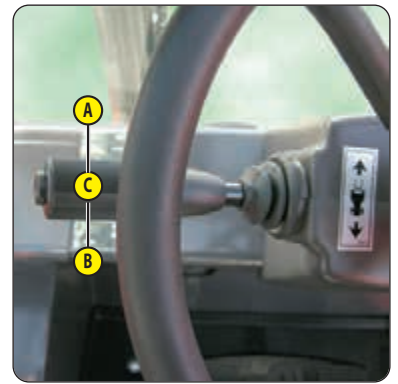

## 17 - PARKING BRAKE

To prevent accidental loosening or release, the lever is fitted with safety locking.

- To apply the parking brake, pull the lever backwards (position A).
- To loosen the parking brake, release and push the lever forwards (position B).

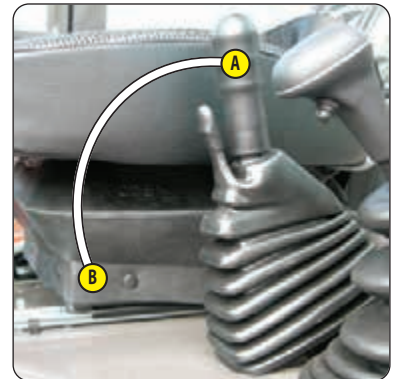

## 18 - HYDRAULIC CONTROLS

### ⚠ IMPORTANT ⚠

*Do not attempt to alter the hydraulic system pressure by interfering with the pressure regulating valve. In the event of suspected malfunction, contact your dealer. ANY ALTERATION MAY RENDER THE WARRANTY NULL AND VOID.*

*Use the hydraulic controls carefully without jerking, to avoid accidents caused by shaking the lift truck.*

Using the hydraulic controls is only possible if the driver is present and correctly sat on his seat.

### LIFTING THE LOAD

- The lever A backwards when lifting.
- The lever A forwards when lowering.

### TILTING THE MAST

- The lever B backward for backward tilting.
- The lever B forwards for forward tilting.

### ATTACHMENT

- The lever C forwards or backwards.



## 19 - HEATER CONTROL (OPTION)

Allows the temperature inside the cab to be adjusted.

- A - With the valve closed, the fan delivers fresh air.
- B - With the valve opened completely, the fan delivers warm air.

The intermediate positions allow the temperature to be adjusted.



## 20 - HEATING VENTS (OPTION)

## 21 - DOOR LOCKS (OPTION)

Two keys are provided with the lift truck to enable the cabin to be locked.

## 22 - DOOR RELEASE SWITCHES (OPTION)

## 23 - DOCUMENT HOLDER NET

Make sure that the operator's manual is in the right place, i.e. in the document holder net.

NOTE: An OPTION waterproof document-holder exists.

## 24 - FRONT HEADLIGHTS

- A - Left front indicator.
- B - Left front sidelight.
- C - Left front dipped headlight and main beam.
- D - Right front sidelight.
- E - Right front dipped headlight and main beam.
- F - Right front indicator.



## 25 - REAR LIGHTS

- A - Left rear indicator.
- B - Left rear stoplight.  
Left tail light.
- C - Right tail light.  
Right rear stoplight.
- D - Right rear indicator.



## 26 - LEVEL INDICATOR

Enables the operator to check that the lift truck is in the horizontal position.



## 27 - BATTERY CUT-OFF

For quickly disconnecting the battery when working on the electric circuit or when soldering, for example.

**⚠ IMPORTANT ⚠**

*Operate the battery cut-off no less than 30 seconds after having switched off the ignition with the ignition key.*



## 28 - 2 SPEED GEAR BOX SWITCH (HYDROSTATIC TRANSMISSION ONLY)

To change gears: Bring the lift truck to a complete stop, keep the brake pedal fully engage and switch the forward/reverse lever to neutral. Activate the toggle switch (A) to change gears. your selection will illuminate the chosen gear:

- (1) Low Gear: for loading, heavy handling.
- (2) High Gear: for road use, trailer towing, general handling.

NOTE: The gear box automatically returns to high gear when engine is stopped.



# TOWING PIN AND HOOK

## ⚠ IMPORTANT ⚠

*Do not tow a trailer or an attachment that is not in perfect working order.*

*Using a trailer that is not in good condition may affect the steering and braking of the lift truck and therefore the safety of the whole unit.*

*If a third party helps in coupling or uncoupling the trailer, this person must remain permanently visible to the driver and wait until the lift truck has stopped, the handbrake is on and the I.C engine is switched off before performing the operation.*

Located at the rear of the lift truck, this device is used to attach a trailer. Its capacity is limited for each lift truck by the authorized gross vehicle weight, tractive effort and maximum vertical force on the coupling point. This information is given on the manufacturer's plate fixed to each lift truck (see: 2 - DESCRIPTION: IDENTIFICATION OF THE LIFT TRUCK).

- To use a trailer, see current regulations in your country (maximum running speed, braking, maximum weight of trailer, etc.).
- Verify the trailer's condition before using it (tyre condition and pressures, electrical connection, hydraulic hose, brake system...).

## 1 - TOWING PIN

### ⚠ IMPORTANT ⚠

*Be careful not to get your fingers caught or crushed during this operation.*

*Do not forget to put pin back in place.*

*When uncoupling, make sure that the trailer is supported independently.*

### COUPLING AND UNCOUPLING THE TRAILER

- To couple the trailer, position the lift truck as close as possible to the trailer ring.
- Put the handbrake on and switch off the I.C. engine.
- Remove the clip 1, lift the trailer pin 2 and place or remove the trailer ring.





## DESCRIPTION AND USE OF THE OPTIONS

- 1 - ROTATING BEACON LIGHT
- 2 - AIR CONDITIONING CONTROL
- 3 - COOLING VENTS
- 4 - REVERSE SOUND ALARM
- 5 - DIGICODE ANTI-THEFT SYSTEM
- 6 - FINTRONIC ANTI-START SYSTEM
- 7 - ADAPTATION OF DISTRIBUTOR'S 4TH ELEMENT
- 8 - ADAPTATION OF BALANCING VALVE ON TILTING CIRCUIT

### 1 - ROTATING BEACON LIGHT

The revolving light is dismantlable to make it possible, for example, to reduce the bulkiness of the lift truck or to avoid being stolen.

- Loosen nut 1 and remove the rotating beacon light.
- Protect mounting 2 with cap 3.

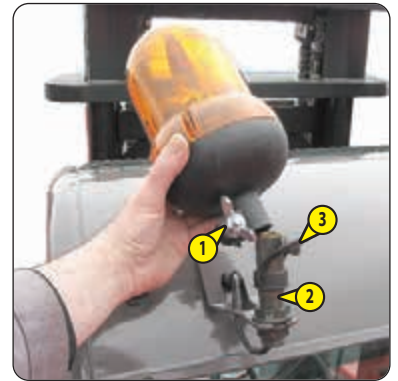

### 2 - AIR CONDITIONING CONTROL

#### ⚠ IMPORTANT ⚠

*The air conditioning only comes on when the forklift truck has been started up.*

*When using your air conditioning, you must work with the doors and windows closed.*

*In winter: So as to ensure correct operation and complete efficiency of the air conditioning unit, start up the compressor once a week, if only for a short spell, so as to lubricate the internal seals.*

*In cold weather: Warm the I.C. engine before switching on the compressor, so as to allow the coolant that has collected in the liquid state at the lowest point of the compressor circuit to turn into gas under the effect of the heat given off by the I.C. engine, as the compressor is liable to be damaged by coolant in the liquid state.*

*If your air conditioning does not seem to be working correctly, have it examined by your dealer (see: 3 - MAINTENANCE: F - EVERY 2000 OPERATING HOURS).*

*Never try to repair any faults yourself.*

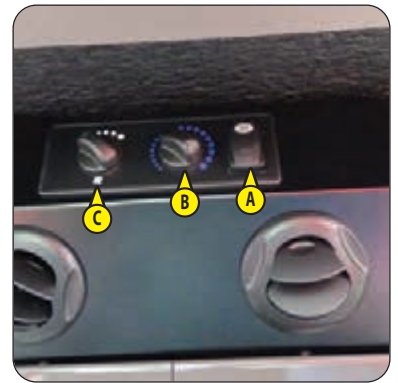

#### DESCRIPTION OF THE AIR CONDITIONING CONTROLS

- A - Air conditioning system ON/OFF control switch with indicator lamp. Only works when control switch "C" set to 1, 2 or 3.
- B - Air temperature control.
- C - Air flow and fan speed control. When this control is set to "0" the air conditioning system will not work.

NOTE: Possible losses of water under the lift truck are due to condensate discharges caused by the drying effect of the installation, especially with high outside temperatures and high relative humidity. For the air conditioning to perform properly, the air intakes must not be blocked by frost, snow or leaves. When the facility is running, at least one of the cab air grilles must be open so as to avoid any risk of freezing to the evaporator.

#### CONDITIONED AIR MODE

The controls must be adjusted in the following way:

- A - Control with signal light on.
- B - At the required temperature.
- C - To the desired position 1, 2 or 3.

### 3 - COOLING VENTS

---



### 4 - REVERSE SOUND ALARM(Not Shown)

---

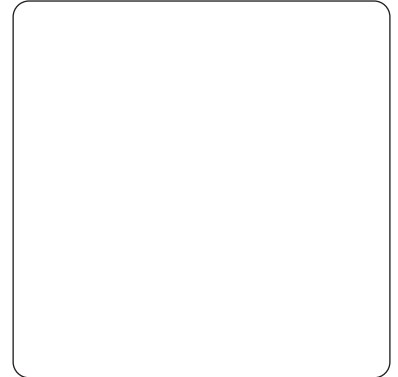

### 5 - DIGICODE ANTI-THEFT SYSTEM(Not Shown)

---

#### OPERATION

- Switch on the lift truck: LED A flashes red.
- Enter your user code followed by "VAL": LED A goes out.
- The entry of each digit of your code is confirmed by LED A lighting up green. If you make an error, press the "ANN" key and re-enter your code in full.
- Start the lift truck within the next 30 seconds; otherwise the anti-theft system will react and LED A flashes red.

NOTE: You can restart the lift truck within 12 seconds of stopping it: after this time, the anti-theft system reacts and LED A flashes red.

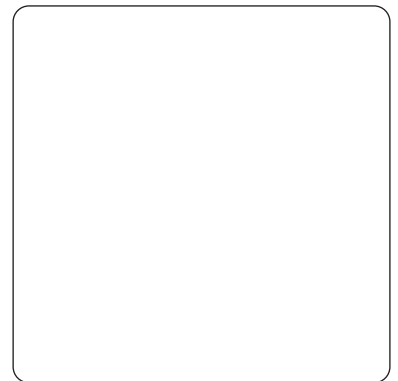

### 6 - FINTRONIC ANTI-START SYSTEM

---

#### OPERATION

- Switch on the lift truck and set the black key A next to the antenna B (maximum 80 mm).
- Wait a few seconds for red led C to go out before starting the lift truck.

NOTE: You can restart the lift truck within 20 seconds of stopping it: after this time, the anti-start system reacts and LED C flashes red.

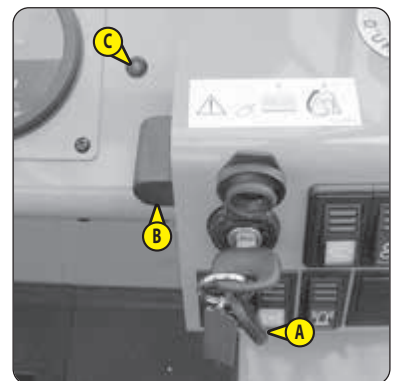

### 7 - ADAPTATION OF DISTRIBUTOR'S 4TH ELEMENT

---

#### ADDITIONAL ACCESSORY

- Lever A forward or backward.





# ***3 - MAINTENANCE***



# TABLE OF CONTENTS

## 3 - MAINTENANCE

<b><i>ORIGINAL MANITOU SPARE PARTS AND EQUIPMENT</i></b>	<b>4</b>
<b><i>FILTERS CARTRIDGES AND BELTS</i></b>	<b>5</b>
<b><i>LUBRICANTS AND FUEL</i></b>	<b>6</b>
<b><i>SERVICING SCHEDULE</i></b>	<b>8</b>
<b><i>A - DAILY OR EVERY 10 HOURS SERVICE</i></b>	<b>10</b>
<b><i>B - EVERY 50 HOURS SERVICE</i></b>	<b>12</b>
<b><i>C - EVERY 250 HOURS OF SERVICE</i></b>	<b>18</b>
<b><i>D - EVERY 500 HOURS OF SERVICE OR EVERY YEAR</i></b>	<b>22</b>
<b><i>E - EVERY 1000 HOURS OF SERVICE OR EVERY 2 YEARS</i></b>	<b>28</b>
<b><i>F - EVERY 2000 HOURS OF SERVICE OR EVERY 2 YEARS</i></b>	<b>34</b>
<b><i>G - OCCASIONAL MAINTENANCE</i></b>	<b>36</b>

# ORIGINAL MANITOU SPARE PARTS AND EQUIPMENT

OUR LIFT TRUCKS MUST BE SERVICED USING ORIGINAL MANITOU PARTS.

## **BY ALLOWING THE USE OF NON ORIGINAL MANITOU PARTS, YOU RISK:**

---

- Legally -to be held responsible in the event of an accident.
- Technically - to cause operating malfunctions or shorten the life of the lift truck.

**⚠ IMPORTANT ⚠**

**THE USE OF COUNTERFEIT PARTS OR COMPONENTS NOT APPROVED BY THE MANUFACTURER,  
WILL CAUSE YOU TO LOSE THE BENEFIT OF THE CONTRACTUAL GUARANTEE.**

## **BY USING ORIGINAL MANITOU PARTS FOR MAINTENANCE OPERATIONS, YOU BENEFIT FROM OUR KNOW-HOW**

---

Through its network, MANITOU provides the user with,

- Know-how and competence.
- The guarantee of high-quality work.
- Original replacement parts.
- Help with preventive maintenance.
- Efficient help with diagnosis.
- Improvements due to experience feedback.
- Operator training.
- Only the MANITOU network has detailed knowledge of the design of the lift truck and therefore the best technical ability to provide maintenance.

**⚠ IMPORTANT ⚠**

**ORIGINAL REPLACEMENT PARTS ARE DISTRIBUTED EXCLUSIVELY BY MANITOU AND ITS DEALER NETWORK.**

***The dealer network list is available on the MANITOU web site [www.manitou.com](http://www.manitou.com)***

# FILTERS CARTRIDGES AND BELTS

## I.C. ENGINE

I.C. ENGINE OIL FILTER  
Change: 500 H

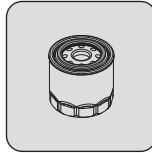

ENGINE CRANKCASE VENTILATION FILTER  
Change: 1000 H

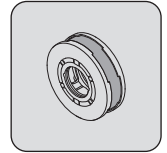

DRY AIR FILTER CARTRIDGE  
Change: 500 H

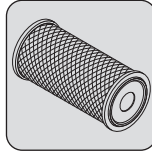

FUEL TANK BREATHER  
Change: 1000 H

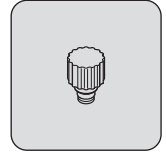

FUEL PRE-FILTER CARTRIDGE  
Change: 500 H

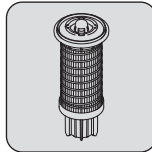

ALTERNATOR BELT  
Change: 3000 H

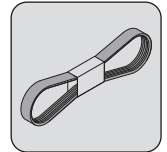

FUEL FILTER CARTRIDGE  
Change: 500 H

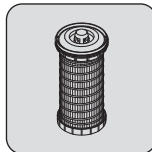

COMPRESSOR BELT  
(OPTION AIR CONDITIONING)

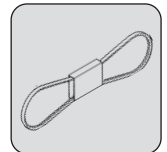

SAFETY DRY AIR FILTER CARTRIDGE  
Change: 1000 H

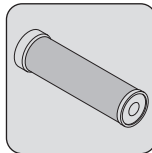

CYCLONIC PRE-FILTER (OPTION)  
Clean: 10 H

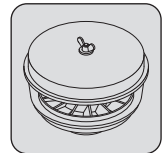

## TRANSMISSION

GEAR BOX OIL FILTER  
Change: 500 H

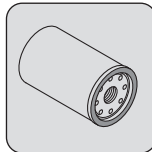

## HYDRAULIC

HYDRAULIC RETURN OIL FILTER CARTRIDGE  
Change: 500 H

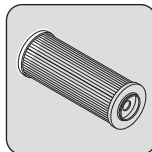

SUCTION STRAINER FOR HYDRAULIC OIL TANK  
Clean: 1000 H

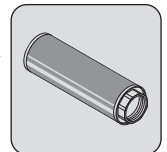

BREATHER FOR THE HYDRAULIC OIL TANK  
Change: 1000 H

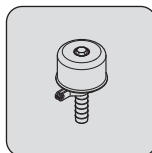

HYDROSTATIC TRANSMISSION RETURN FIL.  
Change: 1000 H

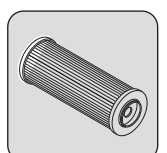

## CAB (OPTION)

CAB VENTILATION FILTERS  
Clean: 50 H  
Change: 250 H

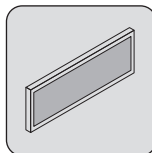

## FRONT AXLE

FRONT AXLE COOLING CIRCUIT FILTER  
Change: 500 H

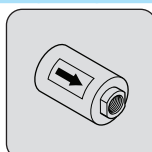

# LUBRICANTS AND FUEL

## ⚠ IMPORTANT ⚠

**USE THE RECOMMENDED LUBRICANTS AND FUEL:**  
 - For topping up, oils may not be miscible.  
 - For oil changes, MANITOU oils are perfectly appropriate.

### DIAGNOSTIC ANALYSIS OF OILS

If a service or maintenance contract has been organized with the dealer, a diagnostic analysis of engine, transmission and axle oils may be requested depending on the rate of use.

#### (\*) RECOMMENDED FUEL SPECIFICATION:

Use a high-quality fuel to obtain optimal performance of the I.C. engine.

- Type of diesel fuel EN590
- Type of diesel fuel ASTM D975

#### (\*\*) BRAKE CIRCUIT

NAH3 and Dexron III-H are not compatible with LHM-S. The use of LHM-S is Allowed. When Switching from LHM-S to NA H3 or Dexron III H or vice versa, drain all oil from system.

I.C. ENGINE		
ORGANS TO BE LUBRICATED	CAPACITY	RECOMMENDATION
I.C. ENGINE	8 Litters	MANITOU Oil GOLD "API CJ-4 ; ACEA E9"
COOLING CIRCUIT	12,3 Litters	Cooling liquid (protection - 35°)
FUEL TANK	85 Litters	Diesel fuel (*)

TRANSMISSION 4 SPEED		
ORGANS TO BE LUBRICATED	CAPACITY	RECOMMENDATION
GEAR BOX	15,5 Litters	MANITOU Oil Automatic transmission

TRANSMISSION HYDROSTATIC MODELS		
ORGANS TO BE LUBRICATED	CAPACITY	RECOMMENDATION
GEARBOX HYDROSTATIC	2.27 Litters	Shell: Spirax DH80w90 Citgo:Premium Gear MP 80w90

MAST	
ORGANS TO BE LUBRICATED	RECOMMENDATION
MAST LIFTING CHAINS	MANITOU Lubricant Chain special (aerosol)
GREASING OF THE MAST	MANITOU Grease BLACK multi-purpose

HYDRAULIC		
ORGANS TO BE LUBRICATED	CAPACITY	RECOMMENDATION
HYDRAULIC OIL TANK	80 Litters	MANITOU Oil Hydraulic ISO VG 46

BRAKE	
ORGANS TO BE LUBRICATED	RECOMMENDATION
BRAKE CIRCUIT	(**) NA H3 (**) Dexron III-H

<b>CAB</b>		
<b>ORGANS TO BE LUBRICATED</b>	<b>RECOMMENDATION</b>	
CAB DOOR (OPTION)	MANITOU Grease BLUE multi-purpose	
WINDSCREEN WASHER TANK	Windscreen washer fluid	
<b>FRONT AXLE</b>		
<b>ORGANS TO BE LUBRICATED</b>	<b>CAPACITY</b>	<b>RECOMMENDATION</b>
FRONT AXLE DIFFERENTIAL	6,8 Liters	MANITOU Oil Special immersed brakes
FRONT WHEELS REDUCERS	0,75 Liter	MANITOU Oil SAE80W90 Mechanical transmission

<b>REAR AXLE</b>	<b>M 26/30-2+H ST3B</b>	<b>M 40/50-2+H ST3B</b>
<b>ORGANS TO BE LUBRICATED</b>	<b>CAPACITY</b>	<b>RECOMMENDATION</b>
SWIVEL PINS STEERING CYLINDER REAR AXLE OSCILLATION		MANITOU Grease BLUE multi-purpose

<b>REAR AXLE</b>	<b>M 26/30-4+H ST3B</b>	<b>M 40/50-4+H ST3B</b>
<b>ORGANS TO BE LUBRICATED</b>	<b>CAPACITY</b>	<b>RECOMMENDATION</b>
REAR AXLE DIFFERENTIAL	6,5 Liters	MANITOU Oil SAE80W90 Mechanical transmission
REAR WHEELS REDUCERS	0,75 Liter	MANITOU Oil SAE80W90 Mechanical transmission
REAR WHEELS REDUCERS PIVOTS REAR AXLE OSCILLATION		MANITOU Grease BLUE multi-purpose

# SERVICING SCHEDULE



(1): MANDATORY 500 HOUR OR 6 MONTH SERVICE. This service must be carried out after approximately the first 500 hours of operation or within the 6 months following the start-up of the machine (whichever occurs first).

(2): Every 10 hours during the first 50 hours then a last service at 250 hours.

(3): Contact your manufacturer.

A = ADJUST, C = CHECK, G = GREASE, N = CLEAN, P = BLEED, R = REPLACE, V = DRAIN	PAGE	(1)	DAILY OR EVERY 10 HOURS OF SERVICE	EVERY 50 HOURS OF SERVICE	EVERY 250 HOURS OF SERVICE	EVERY 500 HOURS OF SERVICE OR EVERY YEAR	EVERY 1000 HOURS OF SERVICE OR EVERY 2 YEARS	EVERY 2000 HOURS OF SERVICE OR EVERY TWO YEARS	EVERY 3000 HOURS OF SERVICE	EVERY 4000 HOURS OF SERVICE	OCCASIONALLY
<b>I.C. ENGINE</b>											
- I.C. engine oil level	3-10		C								
- Cooling liquid level	3-10	C	C								
- Fuel level	3-11	C	C								
- Fuel pre-filter	3-11		C								
- Cyclonic pre-filter (option)	3-11		N								
- Dry air filter cartridge	3-12/23			C/N		R					
- Radiator core	3-12	N		N							
- Compressor belt tension (OPTION Air conditioning)	3-18	C/A			C/A						
- I.C. engine oil	3-22	V				V					
- I.C. engine oil filter	3-22	R				R					
- Fuel pre-filter cartridge	3-23	R				R					
- Fuel filter cartridge	3-24	R				R					
- Engine crankcase ventilation filter	3-28						R				
- Fuel tank	3-28						N				
- Fuel tank breather	3-28						R				
- Safety dry air filter cartridge	3-29						R				
- I.C. engine silent blocks							C (3)				
- I.C. engine rates							C (3)				
- Valves clearances							C (3)				
- Cooling liquid	3-34							V			
- Radiator								C (3)			
- Water pump and the thermostat								C (3)			
- Alternator and the starter motor								C (3)			
- Turbocompressor								C (3)			
- Alternator belt									R (3)		
- Fuel circuit	3-36										P
- "Stationary lift truck" exhaust particle filter	3-37										N
<b>TRANSMISSION</b>											
- Gear box oil level	3-11		C								
- Gear box oil filter	3-24	R				R					
- Gear box oil	3-29	V					V				
- Gear box sump strainer	3-29						N				
- Silentblocks in the gear box							C (3)				
- Gear box controls							C (3)				
- Transmission pressures								C (3)			
- Hydrostatic pump pressure								C (3)			
- Hydrostatic motor pressure								C (3)			
<b>TIRES</b>											
- Tire pressure	3-12	C		C							
- Wheel nuts torque	3-12	C		C							
- Wheel nuts tightening torque	3-35	C						C			
- Wheel	3-38										R
<b>MAST</b>											
- Tension and alignment of the mast lifting chains	3-13	C/A		C/A							
- Mast	3-13/14	G		G							
- Mast uprights	3-18	N/G/C			N/G/C						
- Mast lifting chains	3-24	N/C/G				N/C/G					
- Condition of mast unit							C (3)				
- Chain rollers		C						C (3)			
- Mast guide rollers								C (3)			
- Mast bearing rollers									C (3)		
<b>HYDRAULIC</b>											
- Hydraulic oil level	3-14	C		C							
- Hydraulic return oil filter cartridge	3-25	R				R					
- Hydraulic oil	3-30						V				
- Breather for the hydraulic oil tank	3-30						R				
- Suction strainer for hydraulic oil tank	3-30						N				
- Hydraulic pump tubular filter							N (3)				

A = ADJUST, C = CHECK, G = GREASE, N = CLEAN, P = BLEED, R = REPLACE, V = DRAIN	PAGE	(1)	DAILY OR EVERY 10 HOURS OF SERVICE	EVERY 50 HOURS OF SERVICE	EVERY 250 HOURS OF SERVICE	EVERY 500 HOURS OF SERVICE OR EVERY YEAR	EVERY 1000 HOURS OF SERVICE OR EVERY 2 YEARS	EVERY 2000 HOURS OF SERVICE OR EVERY TWO YEARS	EVERY 3000 HOURS OF SERVICE	EVERY 4000 HOURS OF SERVICE	OCCASIONALLY
- Condition of hoses and flexible pipes							C (3)				
- Condition of cylinders (leakage, shafts)							C (3)				
- Hydraulic circuit pressures								C (3)			
- Hydraulic oil tank								N (3)			
<b>BRAKE</b>											
- Brake oil level	3-15	C		C							
- Parking brake	3-19	C/A			C/A						
- Parking brake lever mechanism	3-25	G				G					
- Brake oil							V (3)				
- Brake system							P (3)				
- Brake system pressure							C (3)				
- Brake							A (3)				
<b>STEERING</b>											
- Steering								C (3)			
- Steering swivel joints										C (3)	
<b>CAB</b>											
- Windscreen washer liquid level	3-15	C		C							
- Cab door (option)	3-15	G		G							
- Condenser core (OPTION Air conditioning)	3-16	C/N		C/N							
- Cab ventilation filter (OPTION Air conditioning)	3-16/19	R		N	R						
- Cab ventilation filters	3-25	N				N					
- Seat belt	3-31						C				
- Condition of the rear view mirrors							C (3)				
- Structure							C (3)				
- Air conditioning (OPTION)	3-35							N/C			
<b>ELECTRICITY</b>											
- Condition of wiring harness and cables							C (3)				
- Lights and signals							C (3)				
- Warning indicators							C (3)				
- Front headlights	3-39										A
- Battery failure	3-39										R
<b>FRONT AXLE</b>											
- Front axle differential oil level	3-20				C						
- Front wheels reducers oil level	3-20				C						
- Front axle differential oil	3-26	V				V					
- Front axle cooling circuit filter	3-26	R				R					
- Front wheels reducers oil	3-32	V					V				
- Wear of front axle brake discs										C (3)	
- Front wheels reducers clearance										C (3)	
<b>REAR AXLE M 26/30-2+H ST3B</b>											
- Swivel pins	3-16	G		G							
- Steering cylinder head axles	3-16	G		G							
- Rear axle oscillation	3-16	G		G				G/C (3)			
- Rear axle										C (3)	
<b>REAR AXLE M 26/30-4+ H ST3B M 40/50-4+H ST3B</b>											
- Rear wheels reducers pivots	3-17	G		G							G/C (3)
- Rear axle oscillation	3-17	G		G				G/C (3)			
- Rear axle differential oil level	3-20	C			C						
- Rear wheels reducers oil level	3-20	C			C						
- Rear axle differential oil	3-32	V					V				
- Rear wheels reducers oil	3-32	V					V				
- Rear wheels reducers universal joint										C (3)	
- Rear wheels reducers clearance										C (3)	
<b>REAR AXLE M 40/50-2+H ST3B</b>											
- Swivel pins	3-17	G		G							
- Rear axle oscillation	3-17	G		G				G/C (3)			
- Rear axle										C (3)	
<b>CHASSIS</b>											
- Structure							C (3)				
- Bearings and articulation rings								C (3)			
<b>ATTACHMENTS</b>											
- Forks wear		C (3)				C (3)					
- Attachment carriage							C (3)				
- Condition of attachments							C (3)				
<b>LIFT TRUCK</b>											
- Tow the lift truck	3-40										XXX
- Sling the lift truck	3-40										XXX
- Transport the lift truck on a platform	3-41										XXX

## A - DAILY OR EVERY 10 HOURS SERVICE

### A1 – I.C. ENGINE OIL LEVEL

CHECK

Place the lift truck on level ground with the I.C. engine stopped, and let the oil drain into the sump.

- Open the engine bonnet.
- Pull out dipstick 1.
- Clean the dipstick and check the correct level between the two notches.
- If necessary, add oil (see: 3 - MAINTENANCE: LUBRICANTS AND FUEL) through the filler port 2.
- Visually check that there is no leakage or seepage of oil in the engine.



### A2 – COOLING LIQUID LEVEL

CHECK

Place the lift truck on level ground with the I.C. engine stopped, and allow the I.C. engine to cool.

#### ⚠ IMPORTANT ⚠

*To avoid any risk of spraying or burning, wait until the engine has cooled down before removing the cooling circuit filler plug. If the cooling liquid is very hot, add only hot cooling liquid (80 °C). In an emergency, you can use water as a cooling liquid, then change the cooling circuit liquid as soon as possible (see: 3 - MAINTENANCE: F1 - COOLING LIQUID).*

- Open the I.C. engine bonnet.
- Check the correct level in the middle of gauge 1.
- If necessary, add cooling liquid (see: 3 - MAINTENANCE: LUBRICANTS AND FUEL).
- Slowly turn the cap of the radiator 2 up to the safety stop.
- Allow the pressure and the steam to escape.
- Press down and turn the cap so as to release it.
- Add cooling liquid via filler port 3 up to the middle of gauge 1.
- Lubricate slightly the filler neck in order to facilitate the setting and the removal of the radiator cap.
- Check visually that there is no leakage in the radiator and pipes.



### A3 – FUEL LEVEL

CHECK

Keep the fuel tank full, to reduce as much as possible any condensation due to the atmospheric conditions.

**⚠ IMPORTANT ⚠**

*Never smoke or approach with a flame during filling operations or when the tank is open. Never refill while I.C. engine is running.*

- Check the fuel gauge on the instrument panel.
- If necessary, add diesel (see: 3 - MAINTENANCE: LUBRICANTS AND FUEL).
- Open the access panel for fuel filling.
- Remove protective casing 1 using the switch key.
- Fill the fuel tank with clean diesel filtered through the filler port 2.
- Refit the cap.
- Visually check that there is no leakage in the tank and pipes.

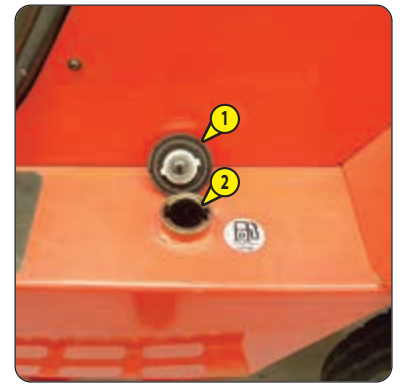

### A4 – FUEL PRE-FILTER

CHECK

**⚠ IMPORTANT ⚠**

*Carefully clean the outside of the pre-filter and its holder, to prevent dust from getting into the system.*

- Open the engine bonnet.
- Check for the presence of water in pre-filter tank 1 and drain if necessary.
- Place a receptacle under the drain plug 2 and loosen by two to three turns.
- Open bleed screw 3.
- Allow the diesel fuel to flow out until it is free from impurities and water.
- Retighten drain plug 2 and bleed screw 3.

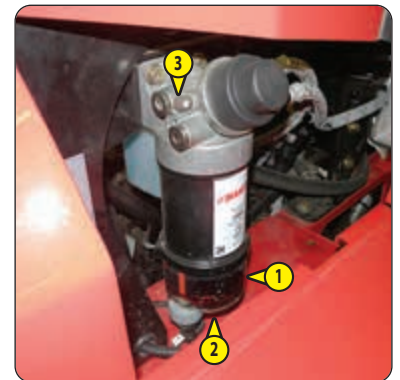

### A5 – CYCLONIC PRE-FILTER (OPTION)

CLEAN

The cleaning interval is given as a guide, however the prefilter must be emptied as soon as impurities reach the MAXI level on the tank.

**⚠ IMPORTANT ⚠**

*When cleaning, take care not to let impurities into the dry air filter.*

- Loosen nut 1 remove cover 2 and empty the tank.
- Clean the prefilter unit with a clean dry cloth and reassemble the unit.



### A6 – GEAR BOX OIL LEVEL

CHECK

Place the lift truck on level ground with the I.C. engine cold and idling.

- Open the engine bonnet.
- Pull out dipstick 1.
- Wipe the dipstick and check the correct level at the upper mark.
- If necessary, add oil (see: 3 - MAINTENANCE: E3 - GEAR BOX OIL).
- Visually check that there is no leakage or seepage of oil in the transmission.

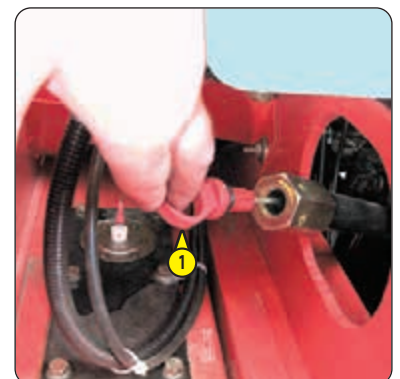

## B - EVERY 50 HOURS SERVICE

Carry out the operations described previously as well as the following operations.

### B1 – DRY AIR FILTER CARTRIDGE

CHECK - CLEAN

In case of use in a heavily dust laden atmosphere, there are pre-filtration cartridges (see: 3 - MAINTENANCE: FILTERS CARTRIDGES AND BELTS). Also, the checking and cleaning periodicity of the cartridge must be reduced.

#### ⚠ IMPORTANT ⚠

*If the clogging indicator light comes on, this operation must be carried out as quickly as possible (1 hour maximum). The cartridge must not be cleaned more than seven times, after which the cartridge must be changed. Never use the lift truck without an air filter or with a damaged air filter.*

- For the disassembly and reassembly of the cartridge, see: 3 - MAINTENANCE: D3 - DRY AIR FILTER CARTRIDGE.
- Clean the filter cartridge using a compressed air jet (max. pressure 3 bar) directed from the top to the bottom and from the inside towards the outside at a minimum distance of 30 mm from the cartridge wall.
- Cleaning is completed when there is no more dust on the cartridge.

#### ⚠ IMPORTANT ⚠

*Respect the safety distance of 30 mm between the air jet and the cartridge to avoid tearing or making a hole in the cartridge. The cartridge must not be blown anywhere near the air filter box. Never clean the cartridge by tapping it against a hard surface. Your eyes must be protected during this intervention.*

- Clean the cartridge seal surfaces with a damp, clean lint-free cloth and grease with a silicone lubricant (MANITOU reference: 479292).
- Check visually the outer condition of the air filter and its mounts. Verify the condition of the hoses and their mounts also.

#### ⚠ IMPORTANT ⚠

*Never clean the dry air filter cartridge by washing it in liquid. Do not clean by any means the safety cartridge located inside the filter cartridge, change it for a new one if it is clogged or damaged.*

### B2 – RADIATOR CORE

CLEAN

#### ⚠ IMPORTANT ⚠

*In a polluting atmosphere, clean the radiator core every day. Do not use a water jet or high-pressure steam as this could damage the radiator fins.*

- Open the engine bonnet.
- If necessary, clean the suction grid on the engine hood.
- Using a soft cloth, clean the radiator in order to remove as much dirt as possible.
- Clean the radiator using a compressed air jet aimed at the engine towards the radiator, in the opposite direction to the cooling air flow.



### B3 – TYRE PRESSURE AND WHEEL NUT TORQUES

CHECK

#### ⚠ IMPORTANT ⚠

*Check that the air hose is correctly connected to the tyre valve before inflating and keep all persons at a distance during inflation. Respect the recommended tyre pressures given.*

- Check the condition of the tyres, to detect cuts, protuberances, wear, etc.
- Check the torque load of the wheel nuts. Non-compliance with this instruction can cause damage and rupture to the wheel bolts and distortion to the wheels.
- Check and restore tyre pressures if necessary (see: 2 - DESCRIPTION: TYRES).

NOTE: There is an OPTIONAL wheel toolkit

## B4 – TENSION AND ALIGNMENT OF THE MAST LIFTING CHAINS

CHECK - ADJUST

M 26/30-2+H ST3B M 26/30-4+H ST3B

Place the lift truck on level ground with the mast in a vertical position and the forks raised approximately 200 mm.

### ⚠ IMPORTANT ⚠

*These checks are important for the good working operation of the mast. In case of technical faults, consult your dealer.*

- Check the alignment of the mast lifting chains between the carriage's chain fasteners and the chain rollers.
- Manually verify the chain tension, if necessary adjust as following while ensuring that the carriage is perpendicular to the mast.
- Loosen nut 1.
- Loosen the lock nut 2 of the chain tension adjuster.
- Adjust the tension by tightening or loosening the nut 3 while checking the alignment of the lifting chains.
- Then block the lock nut 2 and the nut 3.
- Retighten the nut 1.

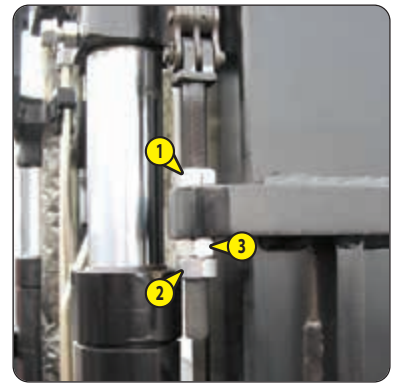

## B5 – TENSION AND ALIGNMENT OF THE MAST LIFTING CHAINS

CHECK - ADJUST

M 40/50-2+H ST3B M 40/50-4+H ST3B

Place the lift truck on level ground with the mast in a vertical position and the forks raised approximately 200 mm.

### ⚠ IMPORTANT ⚠

*These checks are important for the good working operation of the mast. In case of technical faults, consult your dealer.*

- Check the alignment of the mast lifting chains between the carriage's chain fasteners and the chain rollers.
- Manually verify the chain tension, if necessary adjust as following while ensuring that the carriage is perpendicular to the mast.
- Loosen the lock nut 1 of the chain tension adjuster.
- Adjust the tension by tightening or loosening the nut 2 while checking the alignment of the lifting chains.
- Then block the lock nut 1 and the nut 2.

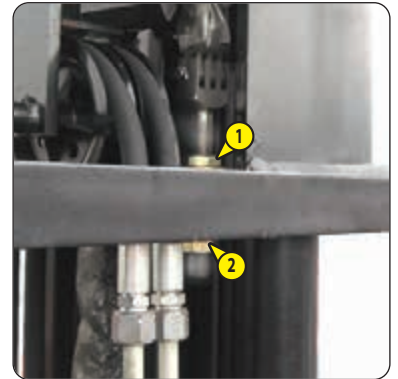

## B6 – MAST

GREASE

M 26/30-2+H ST3B M 26/30-4+H ST3B

To be carried out weekly, if the lift truck has been operated for less than 50 hours during the week.

### ⚠ IMPORTANT ⚠

*In the event of prolonged use in an extremely dusty or oxidising atmosphere, reduce this interval to 10 working hours or every day.*

Clean and lubricate the following points with grease (see: 3 - MAINTENANCE: LUBRICANTS AND FUEL) and remove the surplus of grease.

- 1 - Lubricators of the articulation axles at the foot of the mast (2 lubricators).
- 2 - Lubricators of the tilt cylinders head axles (2 lubricators).
- 3 - Lubricators of the tilt cylinders head axles (2 lubricators).

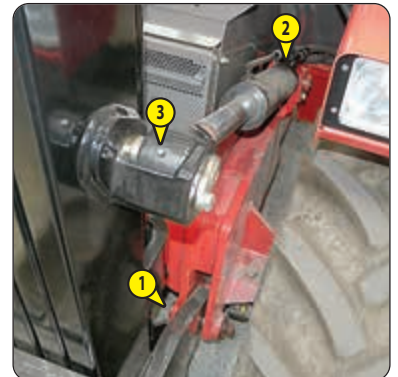

## B7 – MAST

GREASE

M 40/50-2+H ST3B M 40/50-4+H ST3B

To be carried out weekly, if the lift truck has been operated for less than 50 hours during the week.

### ⚠ IMPORTANT ⚠

*In the event of prolonged use in an extremely dusty or oxidising atmosphere, reduce this interval to 10 working hours or every day.*

Clean and lubricate the following points with grease (see: 3 - MAINTENANCE: LUBRICANTS AND FUEL) and remove the surplus of grease.

- 1 - Lubricators of the articulation axles at the foot of the mast (2 lubricators).
- 2 - Lubricators of the tilt cylinders head axles (2 lubricators).
- 3 - Lubricators of the tilt cylinders head axles (2 lubricators).
- 4 - Lubricators of upper guide rollers on mast (2 lubricators).
- 5 - Lubricators of lower guide rollers on mast (2 lubricators).

NOTE: With wide tyre OPTION, raise the forks approximately 2m in order to lubricate the lower mast guide rollers via port 6.



## B8 – HYDRAULIC OIL LEVEL

CHECK

Place the lift truck on level ground with the I.C. engine stopped and mast tilted backward and lowered as far as possible.

### ⚠ IMPORTANT ⚠

*Use a clean funnel and clean the underside of the oil drum before filling.*

- Refer to the level gauge 1.
- The level is correct when it is mid-way between the two indicator marks.
- If necessary, add oil (see: 3 - MAINTENANCE: LUBRICANTS AND FUEL).
- Remove the filler cap lock 2.
- Remove cap 3.
- Add oil through filler port 4.
- Refit the filler cap and its lock.
- Visually check that there is no leakage in the tank and pipes.

Always maintain the oil level at maximum as cooling depends on the oil flowing through the tank.

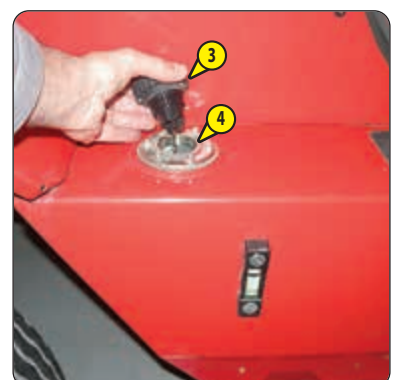
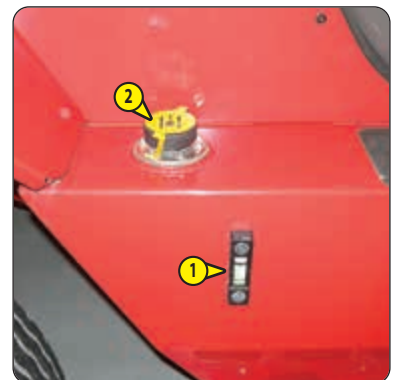

647122 (28/10/2024)  
M26/30-2 + H ST3B / M26/30-4 + H ST3B  
M40/50-2 + H ST3B / M40/50-4 + H ST3B

## B9 – BRAKE OIL LEVEL

CHECK

Place the lift truck on level ground.

### ⚠ IMPORTANT ⚠

*If the braking oil level is abnormally low, consult your dealer.*

- Remove the front plate 1.
- The level is correct when it is at the MAX level on the tank.
- If necessary, add oil (see: 3 - MAINTENANCE: LUBRICANTS AND FUEL) through the filler port 2.
- Visually check that there is no leakage in the tank and pipes.
- Refit the front plate 1.



## B10 – WINDSCREEN WASHER LIQUID LEVEL

CHECK

- Open the engine bonnet.
- Visually check the level.
- If necessary, add windscreen washer fluid (see: 3 - MAINTENANCE: LUBRICANTS AND FUEL) through the filler port 1.



## B11 – CAB DOOR (OPTION)

GREASE

Clean and lubricate the points 1 (4 nipples) with grease (see: 3 - MAINTENANCE: LUBRICANTS AND FUEL) and remove the surplus of grease.



## B12 – CONDENSER CORE (OPTION AIR CONDITIONING)

CHECK - CLEAN

### ⚠ IMPORTANT ⚠

*In a polluting atmosphere, clean the radiator core every day. Do not use a water jet or high-pressure steam as this could damage the condenser fins.*

- Visually check whether the condenser is clean and clean it if necessary.
- Clean the condenser using a compressed air jet aimed in the same direction as the air flow.
- Clean with the fans running for best results.

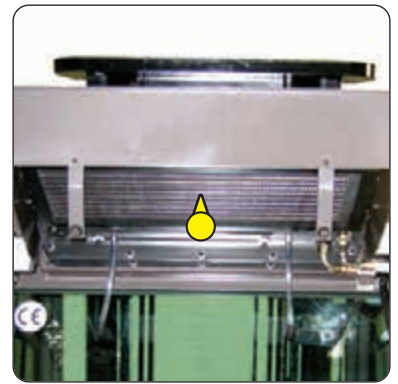

## B13 – CAB VENTILATION FILTER (OPTION AIR CONDITIONING)

CLEAN

- Lift out protective casing 1.
- Lift out cab ventilation filter 2
- Clean the filter with a compressed air jet.
- Check its condition and change if necessary (see: 3 - MAINTENANCE: FILTERS CARTRIDGES AND BELTS).
- Refit the filter and protective casing.

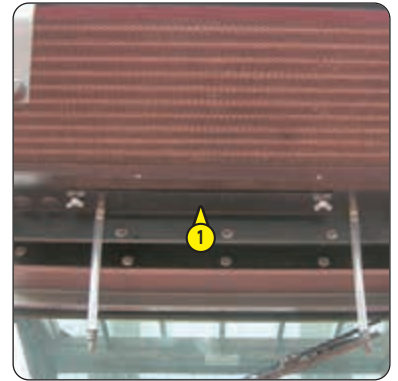

## B14 – REAR AXLE

GREASE

M 26/30-2+H ST3B

Clean and lubricate the following points with grease (see: 3 - MAINTENANCE: LUBRICANTS AND FUEL) and remove the surplus of grease.

- 1 - Lubricators of the swivel pins (6 lubricators).
- 2 - Lubricator of the steering cylinder head axle (4 lubricators).
- 3 - Lubricators of the rear axle oscillation pin (2 lubricators).

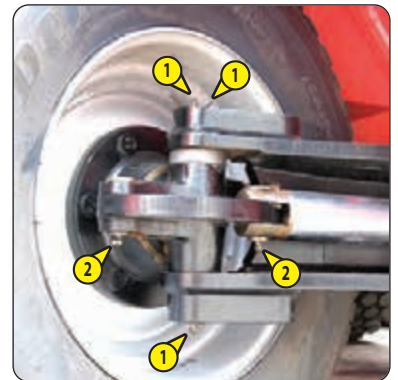

647122 (28/10/2024)  
M26/30-2 + H ST3B / M26/30-4 + H ST3B  
M40/50-2 + H ST3B / M40/50-4 + H ST3B

## B15 – REAR AXLE

### GREASE

M 26/30-4+H ST3B M 40/50-4+H ST3B

Clean and lubricate the following points with grease (see: 3 - MAINTENANCE: LUBRICANTS AND FUEL) and remove the surplus of grease.

- 1 - Lubricators of the rear wheel reduction gear pivots (2 lubricators).
- 2 - Lubricators of the rear axle oscillation pin (2 lubricators).



## B16 – REAR AXLE

### GREASE

M 40/50-2+H ST3B

Clean and lubricate the following points with grease (see: 3 - MAINTENANCE: LUBRICANTS AND FUEL) and remove the surplus of grease.

- 1 - Lubricators of the swivel pins (4 lubricators).
- 2 - Lubricators of the rear axle oscillation pin (2 lubricators).

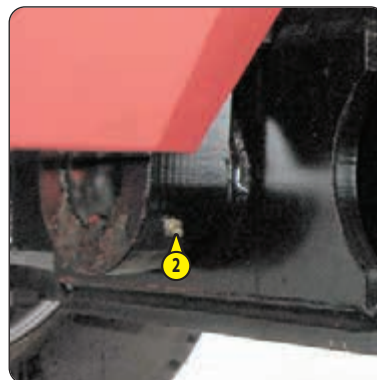
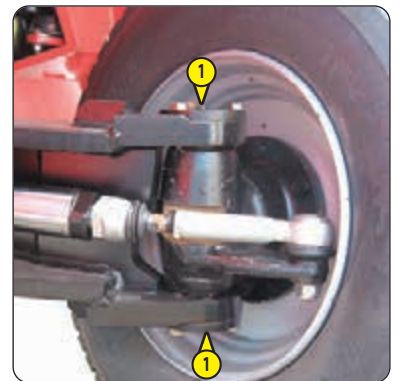

## C - EVERY 250 HOURS OF SERVICE

Carry out the operations described previously as well as the following operations.

### C1 – COMPRESSOR BELT TENSION (OPTION AIR CONDITIONING)

CHECK - ADJUST

#### ⚠ IMPORTANT ⚠

*If the compressor belt has to be changed, check the tension again after the first 20 hours of operation.*

- Open the engine bonnet.
- Check the belt for signs of wear and cracks and change if necessary (see: 3 - MAINTENANCE: FILTERS CARTRIDGES AND BELTS).
- Check the belt tension between the pulleys of the crankshaft and of the alternator.
- Under a normal pressure exerted with the thumb (45N), the tension should be approximately 10 mm.
- Adjust if necessary.
- Loosen the screws 1 by two to three turns.
- Swivel the alternator assembly so as to obtain the belt tension required.
- Retighten screws 1 (tightening torque 22 N.m).

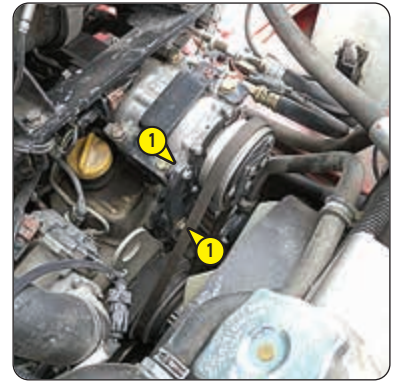

### C2 – MAST UPRIGHTS

CLEAN - GREASE

M 40/50-2+H ST3B M 40/50-4+H ST3B

OPERATION TO BE PERFORMED BEFORE STARTING-UP A NEW LIFT TRUCK AND A FINAL TIME AFTER 250 HOURS SERVICE.

#### ⚠ IMPORTANT ⚠

*These checks are important for the proper operation of the jib. In case of technical faults, consult your dealer.*

- Clean and remove the grease along the entire length of the mast uprights.
- Pay particular attention in the event where the lift truck is used in an environment containing abrasive particles.
- Carefully inspect the different rollers for any traces of wear and replace if necessary.
- Very lightly grease the mast over its entire length (see: 3 - MAINTENANCE: LUBRICANTS AND FUEL).



### C3 - PARKING BRAKE

CHECK - ADJUST

**⚠ IMPORTANT ⚠**

*The manufacturer's settings of the stops must never be changed.*

Place the lift truck on a slope less than 15 % with the rated load in the transport position.

- Check the tightening adjustment by locking the parking brake in position A.
- The adjustment is correct when the lift truck is held stationary on a slope.
- Adjust if necessary.

#### ADJUSTING THE PARKING BRAKE CABLE ON THE FRONT AXLE

- Press and release the brake pedal, then release the parking brake in position B.
- Unscrew the nuts 1.
- Adjust the cable by tightening or loosening the nuts 1 to obtain a play of 1,5 mm between the cams 2 and the stops 3.

#### ADJUSTING THE PARKING BRAKE

- Leave the parking brake in position B.
- Progressively tighten the end piece of the lever 4 and recheck braking.
- Repeat the operation until the correct braking adjustment is obtained.

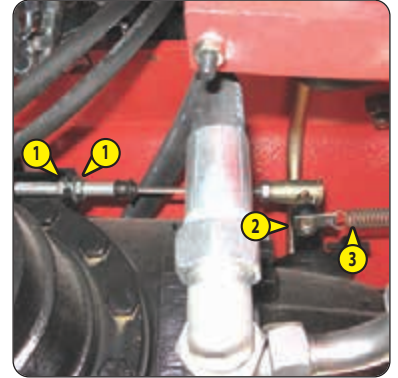
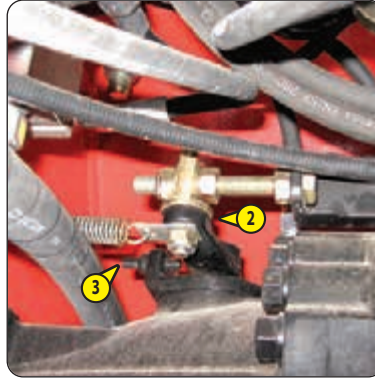
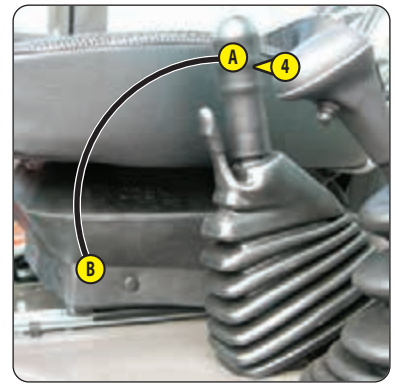

### C4 - CAB VENTILATION FILTER (OPTION AIR CONDITIONING)

CHANGE

- Lift out protective casing 1.
- Lift out cab ventilation filter 2 and replace it with a new one (see: 3 - MAINTENANCE: FILTERS, CARTRIDGES AND BELTS).
- Refit the protective casing.

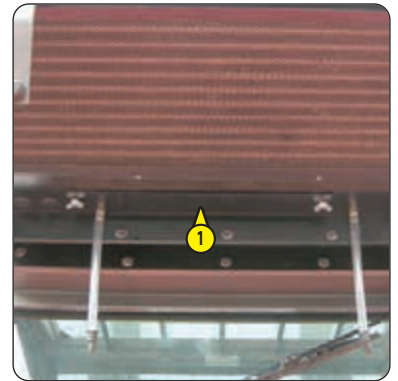

### **C5 - FRONT AXLE DIFFERENTIAL OIL LEVEL**

**CHECK**

Place the lift truck on level ground with the I.C. engine stopped.

- Remove the level plug 1 the oil should be flush with the edge of the hole.
- If necessary, add oil (see: 3 - MAINTENANCE: LUBRICANTS AND FUEL) by the same hole.
- Refit and tighten level plug 1 (tightening torque 34 to 49 N.m).



### **C6 - FRONT WHEELS REDUCERS OIL LEVEL**

**CHECK**

Place the lift truck on level ground with the I.C. engine stopped.

- Check the level on each wheel reduction gear.
- Place level plug 1 in a horizontal position.
- Remove the level plug; the oil should be flush with the edge of the opening.
- If necessary, add oil (see: 3 - MAINTENANCE: LUBRICANTS AND FUEL) through the same opening.
- Refit and tighten the level plug (tightening torque 34 to 49 N.m).



### **C7 - REAR AXLE DIFFERENTIAL OIL LEVEL**

**CHECK**

M 26/30-4+H ST3B    M 26/50-4+H ST3B

Place the lift truck on level ground with the I.C. engine stopped.

- Remove the level plug 1 the oil should be flush with the edge of the hole.
- If necessary, add oil (see: 3 - MAINTENANCE: LUBRICANTS AND FUEL) through the filler port 2.
- Refit and tighten level plug 1 (tightening torque 34 to 49 N.m).

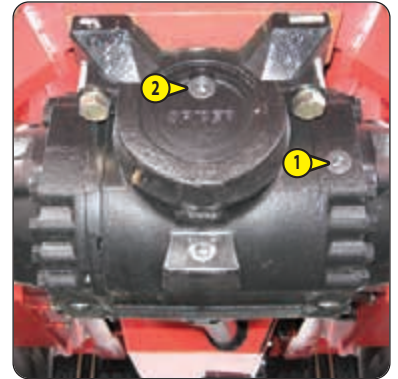

### **C8 - REAR WHEELS REDUCERS OIL LEVEL**

**CHECK**

M 26/30-4+H ST3B    M 26/50-4+H ST3B

Place the lift truck on level ground with the I.C. engine stopped.

- Check the level on each rear wheel reducer.
- Place level plug 1 in a horizontal position.
- Remove the level plug; the oil should be flush with the edge of the hole.
- If necessary, add oil (see: 3 - MAINTENANCE: LUBRICANTS AND FUEL) by the same hole.
- Refit and tighten level plug 1 (tightening torque 34 to 49 N.m).





## D - EVERY 500 HOURS OF SERVICE OR EVERY YEAR

Carry out the operations described previously as well as the following operations.

### D1 – I.C. ENGINE OIL

DRAIN

### D2 – I.C. ENGINE OIL FILTER

CHANGE

Place the lift truck on level ground, let the I.C. engine run at idle for a few minutes, then stop the I.C. engine.

#### ⚠ IMPORTANT ⚠

USE THE RECOMMENDED LUBRICANTS: MANITOU Oil GOLD "API CJ-4 ; ACEA E9"

Discard the waste oil in an ecological manner.

#### DRAINING THE OIL

- Open the engine bonnet.
- Remove the side panel 1.
- Place a container under drain plug 2 and unscrew the plug.
- Remove filling plug 3 to ensure that the oil is drained properly.

#### REPLACEMENT OF THE FILTER

- Remove engine oil filter 4 discard the filter and the filter seal.
- Clean the filter bracket with a clean, lint-free cloth.
- Lightly grease the new oil filter seal and refit the oil filter (see: 3 - MAINTENANCE: FILTERS CARTRIDGES AND BELTS) on the filter bracket.
- Tighten the oil filter (tightening torque 30 N.m).

#### FILLING UP THE OIL

- Refit and tighten the drain plug 2 (tightening torque 30 to 40 N.m).
- Fill up with oil (see: 3 - MAINTENANCE: LUBRICANTS AND FUEL) through filler port 5.

NOTE: For this operation, we recommend you use a funnel fitted with a hose.

- Wait a few minutes to allow the oil to flow into the sump.
- Start the engine and let it run for a few minutes.
- Check for possible leaks at the drain plug and the engine oil filter.
- Stop the engine, wait a few minutes and check the level between the MAX and MIN marks on the dipstick 6.
- Top up the level if necessary.

#### RESETTING THE MAINTENANCE COUNTER TO 500H

- After engine oil replacement, turn off the lamp  to reset the maintenance clock at 500 hours by following the successive steps :
  - fully press the accelerator pedal during 15 to 20 seconds.
  - release the accelerator pedal during 15 to 20 seconds.
  - fully press the accelerator pedal during 15 to 20 seconds.
  - release the accelerator pedal during 15 to 20 seconds.
  - press half stroke the accelerator pedal during 15 to 20 seconds.

NOTE: If the lamp  comes before the 500 hour maintenance, replace the engine oil. This is due to a large number of automatic exhaust particle filter regenerations and "stationary lift truck" exhaust particle filter regenerations.



### D3 – DRY AIR FILTER CARTRIDGE

CHANGE

In case of use in a heavily dust laden atmosphere, there are pre-filtration cartridges, see: 3 - MAINTENANCE: FILTERS CARTRIDGES AND BELTS. Also, the checking and cleaning periodicity of the cartridge must be reduced (up to 250 hours in a heavily laden dust atmosphere and with pre-filtration).

**⚠ IMPORTANT ⚠**

*Change the cartridge in a clean location, with the I.C. engine stopped.  
Never operate the lift truck with the air filter removed or damaged.*

- Open the engine bonnet.
- Loosen the bolts and remove cover 1.
- Gently remove the cartridge 2 taking care to avoid spilling the dust.
- Leave the safety cartridge in place.
- The following parts must be cleaned with a damp, clean lint-free cloth.
  - The inside of the filter and cover.
  - The inside of the filter inlet hose.
  - The gasket surfaces in the filter and in the cover.
- Check pipes and connections between the air filter and the engine and the connection and state of the clogging indicator on the filter.
- Before mounting check the condition of the new cartridge (see: 3 - MAINTENANCE: FILTERS CARTRIDGES AND BELTS).
- Insert the cartridge within the axis of the filter and push it home, pressing against the outer edge and not the centre.
- Reassemble the cover, guiding the valve downwards.



### D4 – FUEL PRE-FILTER CARTRIDGE

CHANGE

**⚠ IMPORTANT ⚠**

*Carefully clean the outside of the pre-filter and its holder, to prevent dust from getting into the system.*

- Open the engine bonnet.
- Scribe a mark A between the head and the housing of the pre-filter.
- Place a receptacle under the drain plug 1 and loosen it by two to three turns.
- Open bleed screw 2 to ensure proper emptying.
- Retighten bleed screw 2 once the pre-filter is emptied.
- Disconnect electrical wiring harness 3 from the fuel pre-filter.
- Unscrew the body of the pre-filter 4.
- Remove cartridge 5 by unscrewing it and discard it together with its seal.
- Clean the inside of the pre-filter head and housing using a brush immersed in clean diesel oil.
- Refit the assembly with a new cartridge and a new seal lubricated with clean engine oil beforehand (see: 3 - MAINTENANCE: FILTERS CARTRIDGES AND BELTS).
- Correctly position the cartridge in the pre-filter housing and screw the assembly by hand only onto the head of the pre-filter until mark A is aligned.
- Replace the fuel filter cartridge.

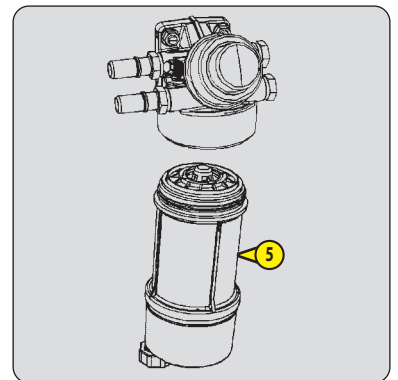
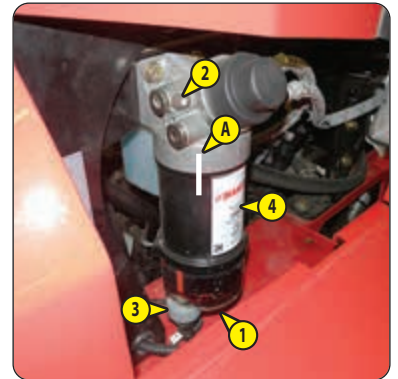

## D5 – FUEL FILTER CARTRIDGE

CHANGE

### ⚠ IMPORTANT ⚠

*Carefully clean the outside of the filter and its holder, to prevent dust from getting into the system.*

- Open the engine bonnet.
- Scribe a mark A between the head and the housing of the filter.
- Place a receptacle under the drain plug 1 and loosen it by two to three turns.
- Open bleed screw 2 to ensure proper emptying.
- Retighten bleed screw 2 once the filter is emptied.
- Undo the filter housing 3.
- Remove cartridge 4 by unscrewing it and discard it together with its seal.
- Clean the inside of the filter head and housing using a brush immersed in clean diesel oil.
- Refit the assembly with a new cartridge and a new seal lubricated with clean engine oil beforehand (see: 3 - MAINTENANCE: FILTERS CARTRIDGES AND BELTS).
- Correctly position the cartridge in the filter housing and screw the assembly by hand only onto the head of the pre-filter until mark A is aligned.
- Bleed the fuel circuit (see: 3 - MAINTENANCE: G1 - FUEL SYSTEM).

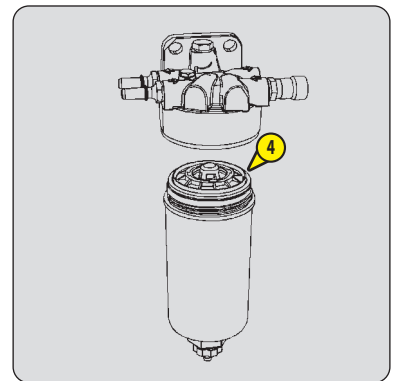

## D6 – GEAR BOX OIL FILTER

CHANGE

### ⚠ IMPORTANT ⚠

*Tighten the gear box oil filter by hand pressure only and lock the filter in place by a quarter turn.*

- Unscrew and discard gear box oil filter 1.
- Carefully clean the filter head with a clean, lint-free cloth.
- Lightly grease the new oil filter seal and fit it on the filter (see: 3 - MAINTENANCE: FILTERS CARTRIDGES AND BELTS).
- Fill up the new gear box oil filter with oil (see: 3 - MAINTENANCE: FILTERS CARTRIDGES AND BELTS).
- Refit the filter, making sure that the seal is correctly positioned and tightened.



## D7 – MAST LIFTING CHAINS

CLEAN - CHECK - GREASE

### ⚠ IMPORTANT ⚠

*In case of technical faults, consult your dealer.*

- Wipe the mast lifting chains 1 with a clean, lint-free cloth, then examine them closely so as to detect any signs of wear.
- Vigorously brush the chains to get rid of any foreign matter, with a hard nylon brush and clean diesel fuel.
- Rinse the chains by means of a paint brush impregnated with clean diesel fuel and dry them with a compressed air jet.
- Moderately lubricate the chains (see: 3- MAINTENANCE: LUBRICANTS AND FUEL).

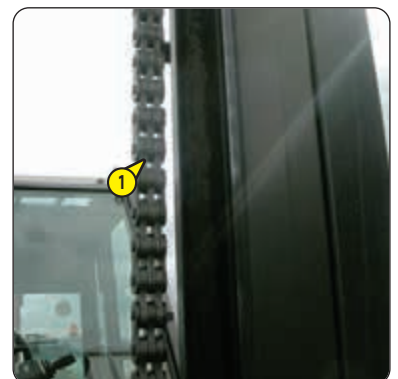

## D8 – HYDRAULIC RETURN OIL FILTER CARTRIDGE

CHANGE

### ⚠ IMPORTANT ⚠

*Thoroughly clean the outside of the filter and its surroundings before any intervention in order to prevent any risk of polluting the hydraulic circuit.*

Stop the I.C. engine and remove the pressure from the circuits by acting on the hydraulic controls.

- Open the engine bonnet.
- Remove the side panel 1.
- Unscrew the fastening screws of the cover 2.
- Remove the hydraulic return oil filter cartridge 3 and replace with a new one (see: 3 - MAINTENANCE: FILTERS CARTRIDGES AND BELTS).
- Make sure that the cartridge is correctly positioned and refit the cover 2.

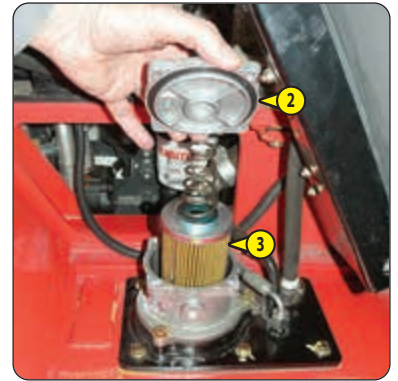

## D9 – PARKING BRAKE LEVER MECHANISM

GREASE

- Clean and grease articulation axles 1 with grease (see: 3 - MAINTENANCE: LUBRICANTS AND FUEL).

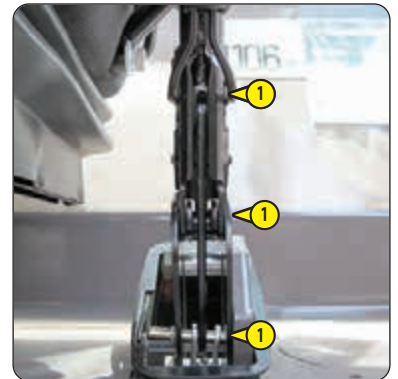

## D10 – CAB VENTILATION FILTERS

CLEAN

- Remove the protective casing 1.
- Lift out cab ventilation filter 2.
- Clean the filter with a compressed air jet.
- Check its condition and change if necessary (see: 3 - MAINTENANCE: FILTERS CARTRIDGES AND BELTS).
- Refit the filter and protective casing.



647122 (28/10/2024)  
M26/30-2 + H ST3B / M26/30-4 + H ST3B  
M40/50-2 + H ST3B / M40/50-4 + H ST3B

## D11 – FRONT AXLE DIFFERENTIAL OIL (with oil cooler)

DRAIN

## D12 – FRONT AXLE OIL COOLER CIRCUIT FILTER

CHANGE

Place the lift truck on level ground with the I.C. engine stopped and the differential oil still warm.

**⚠ IMPORTANT ⚠**

*Dispose of the drain oil in an ecological manner.*

### DRAINING THE OIL

- Place a container under the drain plugs 1 and unscrew them.
- Remove level and filling plug 2 to ensure proper emptying.
- Refit and tighten the drain plugs 1 (tightening torque 34 to 49 N.m).

### REPLACEMENT OF THE FILTER

- Unscrew the half clamp 3.
- Unscrew the two hoses 4 remove the two couplings 5 and replace the filter 6 (see: 3 - MAINTENANCE: FILTERS CARTRIDGES AND BELTS).

**⚠ IMPORTANT ⚠**

*NOTE: Be careful to mount the filter 6 in the same direction as the arrow.*

- Retighten the half clamp 3.

### FILLING UP THE OIL

- Fill up with oil (see: 3 - MAINTENANCE: LUBRICANTS AND FUEL) by the level and filler port 2 until the oil is flush with the opening and refit the plug.
- Start the engine and allow to run for a few minutes to fill the cooling circuit.
- Stop the engine, wait a few minutes and top-up the level.
- The level is correct when the oil level is flush with the edge of the level and filler port 2.
- Check for any possible leaks at the drain plugs.
- Refit and tighten the filler port plug 2 (tightening torque 34 to 49 N.m).

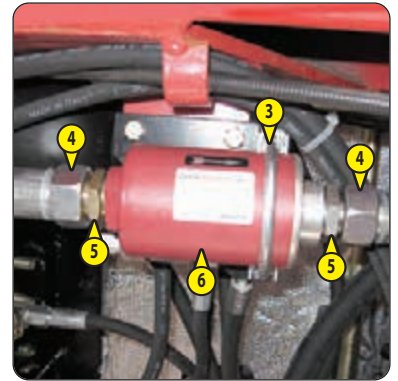
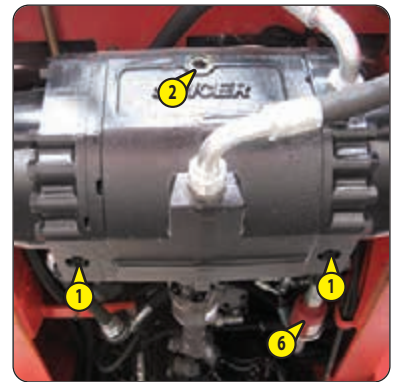



## E - EVERY 1000 HOURS OF SERVICE OR EVERY 2 YEARS

Carry out the operations described previously as well as the following operations.

### E1 – ENGINE CRANKCASE VENTILATION FILTER

CHANGE

- Open the engine bonnet.
- Carefully clean the outside of the filter and its holder, to prevent dust from getting into the system.
- Undo the nuts 1 and remove the cover 2.
- Remove the circlips 3, extract the filter 4 and discard it together with the seal of the cover 2.
- Refit a new seal on the cover and insert a new filter (see: 3 - MAINTENANCE: FILTERS CARTRIDGES AND BELTS).

NOTE: Ensure that the flats of the filter 4 and shaft 5 are aligned.

- Put back the circlips 3, refit the cover 2 and tighten the nuts 1 (tightening torque 25 N.m).

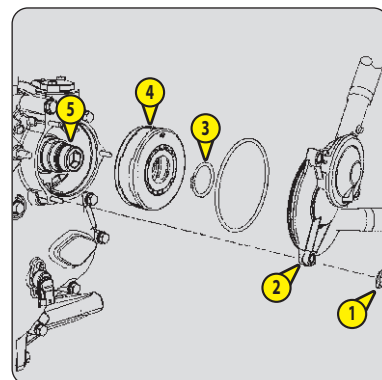
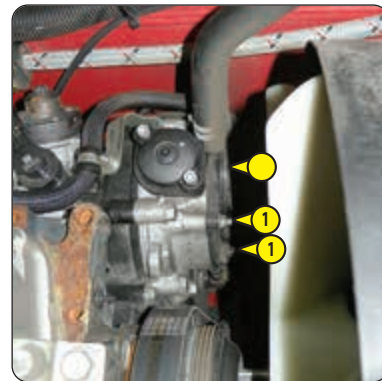

### E2 – FUEL TANK

CLEAN

### E3 – FUEL TANK BREATHER

CHANGE

Place the lift truck on level ground with the I.C. engine stopped.

**⚠ IMPORTANT ⚠**

*While carrying out this operation, do not smoke or work near a flame.*

*Never do any welding or any other operation yourself; this may cause an explosion or fire.*

- Inspect the parts susceptible to leaks in the fuel circuit and in the tank both visually and by touch.
- In the event of a leak, contact your dealer.
- Place a container under drain plug 1 and unscrew the plug.
- Remove filling plug 2 to ensure that the oil is drained properly.
- Rinse out with ten litres of clean diesel through filler port 3.
- Refit and tighten the drain plug (tightening torque 72 to 88 N.m).
- Unscrew the breather 5 and replace it with a new one (see: 3 - MAINTENANCE: FILTERS CARTRIDGES AND BELTS) (tightening torque  $5 \pm 2$  N.m).
- Fill the fuel tank with clean diesel filtered through the filler port.
- Refit the filler plug.
- If necessary, bleed the fuel supply system (see: 3 - MAINTENANCE: G1 - FUEL SUPPLY SYSTEM).

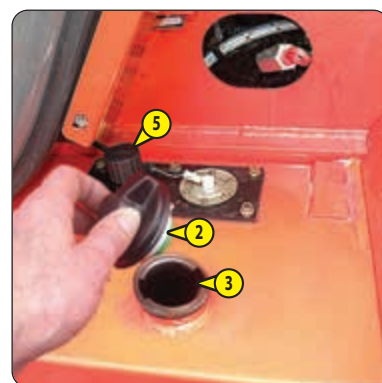
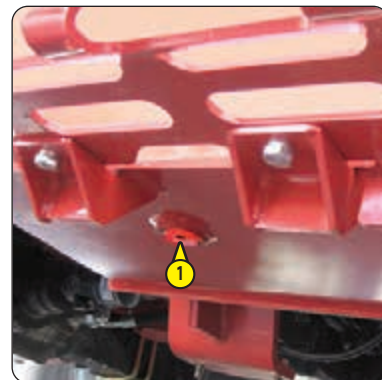

## E4 – SAFETY DRY AIR FILTER CARTRIDGE

### CHANGE

- For the disassembly and reassembly of the cartridge, see: 3 - MAINTENANCE: D3 - DRY AIR FILTER CARTRIDGE.
- Gently remove the dry air filter safety cartridge 1, taking care to avoid spilling the dust.
- Clean the gasket surface on the filter with a damp, clean lint-free cloth.
- Before mounting check the state of the new safety cartridge (see: 3 - MAINTENANCE: FILTERS CARTRIDGES AND BELTS).
- Insert the cartridge within the axis of the filter and push it home, pressing against the outer edge and not the centre.

NOTE: The periodicity for changing the safety cartridge is given for information only. The safety cartridge must be changed for every two changes of the air filter cartridge.



## E5 – GEAR BOX OIL

### DRAIN

## E6 – GEAR BOX SUMP STRAINER

### CLEAN

Place the lift truck on level ground with the I.C. engine stopped, the gear box oil still warm.

**⚠ IMPORTANT ⚠**

*Dispose of the drain oil in an ecological manner.*

### DRAINING THE OIL

- Place a container under drain plug 1 and under cover 2 and unscrew the drain plug.
- Remove dipstick 3 and unscrew filling plug 4 in order to ensure that the oil is drained properly.



### CLEANING THE STRAINER

- Remove cover 2 and set aside the O-ring joint and sealing washer.
- Allow the rest of the oil to drain away.
- Remove and clean the strainer using a compressed air jet.
- Clean the magnetic section on the plate.
- Refit the assembly and tighten up plate 2 (tightening torque 18 to 31 N.m).

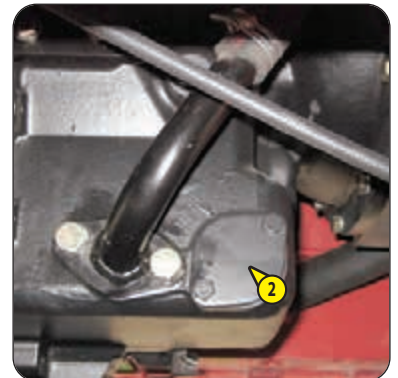

### FILLING UP THE OIL

- Refit and tighten the drain plug 1 (tightening torque 34 to 54 N.m).
- Fill up with oil (see: 3 - MAINTENANCE: LUBRICANTS AND FUEL) through the filler port 5 and refit the plug.
- With the I.C. engine idling, check the correct level at the upper mark on the dipstick 3.
- Check any possible leaks from the drain plug or cover.
- Top up the level if necessary.

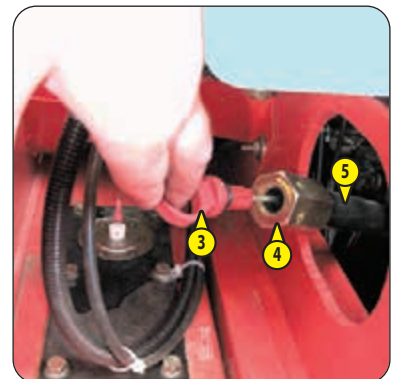

## E7 – HYDRAULIC OIL

DRAIN

## E8 – BREATHER FOR THE HYDRAULIC OIL TANK

CHANGE

## E9 – SUCTION STRAINER FOR HYDRAULIC OIL TANK

CLEAN

Place the lift truck on level ground with the I.C. engine stopped and mast tilted backward and lowered as far as possible.

### ⚠ IMPORTANT ⚠

*Discard the waste oil in an ecological manner.*

*Before any intervention, thoroughly clean the area surrounding the drain plug and the suction cover on the hydraulic tank.*

### DRAINING THE OIL

- Place a container under drain plug 1 and unscrew the plug.
- Open the engine bonnet.
- Remove the filler cap lock 2.
- Remove filling plug 3 to ensure that the oil is drained properly.

### CLEANING THE STRAINER

- Remove the side panel 4.
- Disconnect the hoses 5 (depending on the model).
- Remove the inspection cover 6.
- Unscrew the suction strainer at the bottom of the tank, clean it with the help of a compressed air jet, check its condition and change it, if necessary (see: 3 - MAINTENANCE: FILTERS CARTRIDGES AND BELTS).
- Refit the strainer and the access panel 6.
- Disconnect the hoses 5 (depending on the model).

### REPLACING THE BREATHER

- Unscrew the breather 7 and replace it with a new one (see: 3 - MAINTENANCE: FILTERS, CARTRIDGES AND BELTS).
- Refit the side panel 4.

### FILLING UP THE OIL

- Clean and refit the drain plug 1 (tightening torque 29 to 39 N.m).
- Fill up with oil (see: 3 - MAINTENANCE: LUBRICANTS AND FUEL) through filler port 8.

### ⚠ IMPORTANT ⚠

*Use a clean container and funnel and clean the underside of the oil drum before filling.*

- Observe the oil level on dipstick 9; the oil level should be between the mini and maxi marks on the dipstick.
- Check for any possible leaks at the drain plug.
- Refit the filler cap 3 and its lock 2.

### HYDRAULIC CIRCUIT DECONTAMINATION

- Let the engine run (accelerator pedal at halfway travel) for 5 minutes without using anything on the lift truck, then for 5 more minutes while using completely the hydraulic movements (except the steering system).
- Accelerate the engine at full speed for 1 minute, then activate the steering system.
- This operation makes a pollution abatement of the circuit possible through the hydraulic return oil filter.

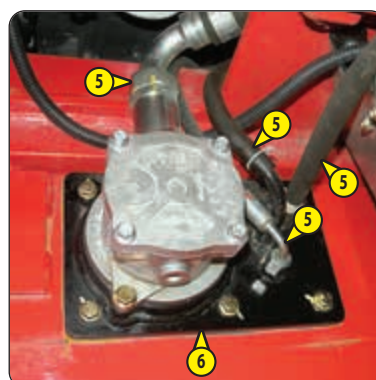
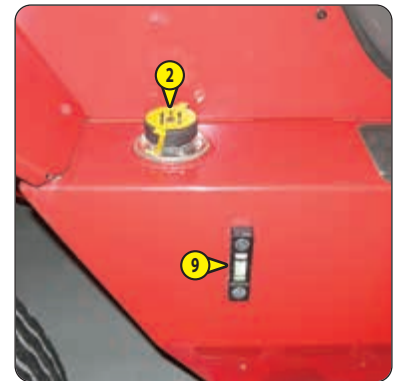
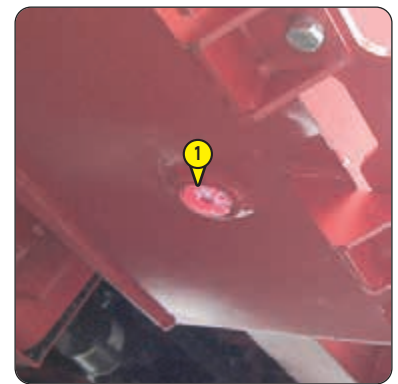

**⚠ IMPORTANT ⚠**

*In no event should the lift truck be used if the seat belt is defective (fixing, locking, cuts, tears, etc.).  
Repair or replace the seat belt immediately.*

## SEAT BELT WITH TWO ANCHORING POINTS

- Check the following points:
  - Fixing of the anchoring points on the seat.
  - Cleanness of the strap and the locking mechanism.
  - Triggering of the locking mechanism.
  - Condition of the strap (cuts, curled edges).

## REELED SEAT BELT WITH TWO ANCHORING POINTS

- Check the points listed above together with the following points:
  - The correct winding of the belt.
  - Condition of the reel guards.
  - Roller locking mechanism when the strap is given a sharp tug.

NOTE: After an accident, replace the seat belt.

## E11 – HYDROSTATIC RETURN OIL FILTER

**⚠ IMPORTANT ⚠**

*To prevent debris from entering the hydraulic circuit, thoroughly  
clean the filter housing before opening*

- Hydrostatic Transmission Models: Remove the Cap.
- Remove the hydraulic return oil filter cartridge and install a new replacement cartridge
- ( see FILTERS CARTRIDGES and BELTS)
- Install the cover cap.

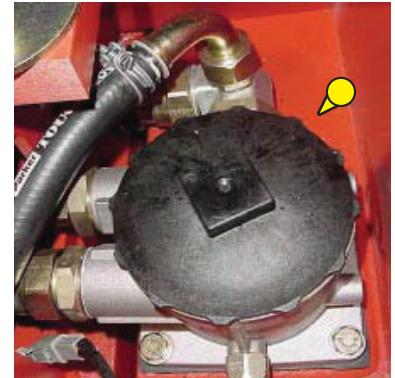

## E12 – FRONT WHEELS REDUCERS OIL

DRAIN

Place the lift truck on level ground with the I.C. engine stopped and the reducers oil still warm.

### ⚠ IMPORTANT ⚠

*Dispose of the drain oil in an ecological manner.*

- Drain and change the oil of each wheel reduction gear.
- Place drain plug 1 in position A.
- Place a container under the drain plug and unscrew the plug.
- Let the oil drain fully.
- Place the drain port in position B, i.e. in a level port.
- Fill up with oil (see: 3 - MAINTENANCE: LUBRICANTS AND FUEL) through level port 1.
- The level is correct when the oil level is flush with the edge of the hole.
- Refit and tighten the drain plug (tightening torque 34 to 49 N.m).

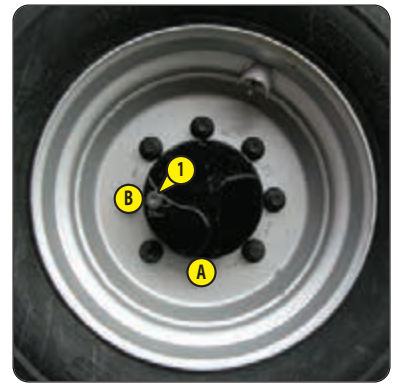

## E13 – REAR AXLE DIFFERENTIAL OIL

DRAIN

M 26/30-4+H ST3B M 40/50-4+H ST3B

Place the lift truck on level ground with the I.C. engine stopped and the d oil still warm.

### ⚠ IMPORTANT ⚠

*Dispose of the drain oil in an ecological manner.*

- Place a container under the drain plugs 1 and unscrew them.
- Remove level plug 2 and filling plug 3 to ensure that the oil is drained properly.
- Refit and tighten the drain plugs 1 (tightening torque 34 to 49 N.m).
- Fill up with oil (see: 3 - MAINTENANCE: LUBRICANTS AND FUEL) through filler port 3.
- The level is correct when the oil level is flush with the edge of opening 2.
- Check for any possible leaks at the drain plugs.
- Refit and tighten level plug 2 (tightening torque 34 to 49 N.m) and filler plug 3 (tightening torque 34 to 49 Nm).

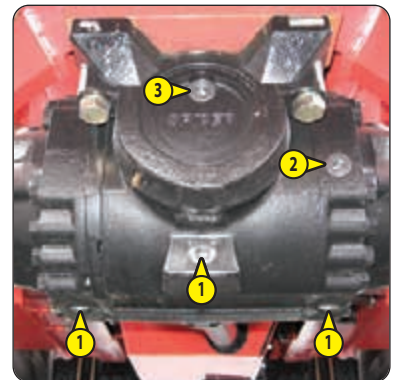

## E14 – REAR WHEELS REDUCERS OIL

DRAIN

M 26/30-4+H ST3B M 40/50-4+H ST3B

Place the lift truck on level ground with the I.C. engine stopped and the reducers oil still warm.

### ⚠ IMPORTANT ⚠

*Dispose of the drain oil in an ecological manner.*

- Drain and change the oil of each wheel reduction gear.
- Place drain plug 1 in position A.
- Place a container under the drain plug and unscrew the plug.
- Let the oil drain fully.
- Place the drain port in position B, i.e. in a level port.
- Fill up with oil (see: 3 - MAINTENANCE: LUBRICANTS AND FUEL) through level port 1.
- The level is correct when the oil level is flush with the edge of the hole.
- Refit and tighten the drain plug (tightening torque 34 to 49 N.m).

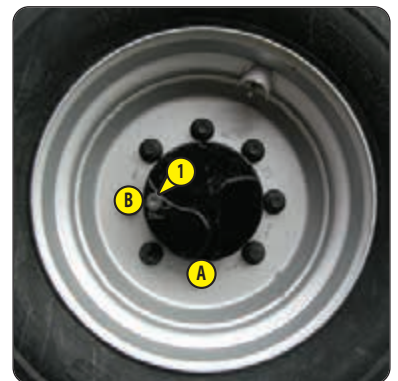



## F - EVERY 2000 HOURS OF SERVICE OR EVERY 2 YEARS

Carry out the operations described previously as well as the following operations.

### F1 - COOLING LIQUID

#### DRAIN

These operations are to be carried out if necessary or every two years at the beginning of winter. Place the lift truck on level ground with the I.C. engine stopped and cold.

#### ⚠ IMPORTANT ⚠

*The I.C. engine does not contain any corrosion resistor and must be filled during the whole year with a mixture containing 25 % of ethylene glycol-based antifreeze.*

#### DRAINING THE LIQUID

- Open the engine bonnet.
- Place a container under hose 1 on the radiator and drain plug 2 of the engine block. Remove the hose and loosen the drain plug.
- Remove radiator filler cap 3.
- Let the cooling circuit drain entirely while ensuring that the ports do not get clogged.
- Check the condition of the hoses as well as the fastening devices and change the hoses if necessary.
- Rinse the circuit with clean water and use a cleaning agent if necessary.

#### FILLING THE LIQUID

- Refit and tighten the hose 1 and the drain plug 2 (tightening torque 40 N.m).
- Slowly fill up the circuit with cooling liquid (see: 3 - MAINTENANCE: LUBRICANTS AND FUEL) to the middle of gauge 4 through filler port 5.
- Refit the filler plug 3.
- Run the engine at idle for a few minutes.
- Check for any possible leaks.
- Check the level and refill if necessary.

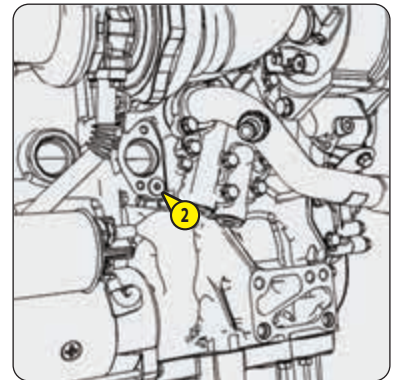

## F2 – WHEEL NUTS TIGHTENING TORQUE

CHECK

- Check the condition of the tyres, to detect cuts, protuberances, wear, etc.
- Check the nuts and bolt tightening torque with a torque wrench.
  - Front tyres: 630 N.m  $\pm$  15 %
  - Rear tyres: 340 N.m  $\pm$  15 %

## F3 – AIR CONDITIONING (OPTION)

CLEANING - INSPECTION

**CLEANING CONDENSER AND EVAPORATOR COILS (\*)**

**CLEANING CONDENSATE TRAY AND RELIEF VALVE (\*)**

**COLLECTING COOLANT TO REPLACE FILTER-DRIER (\*)**

**REFILLING WITH COOLANT AND CHECKING THE THERMOSTATIC CONTROL AND PRESSURE SWITCHES (\*)**

NOTE: When opening the evaporator unit, remember to replace the cover seal.

(\*): (CONSULT YOUR DEALER).

### **⚠ IMPORTANT ⚠**

**DO NOT ATTEMPT TO REPAIR ANY PROBLEMS YOURSELF. ALWAYS REFER TO YOUR MANUFACTURER WHEN REFILLING CIRCUITS, AS THEY HOLD THE CORRECT SPARE PARTS, AS WELL AS HAVING THE NECESSARY TECHNICAL KNOWLEDGE AND TOOLS.**

*In the event of inhalation, take the victim into fresh air, give oxygen or artificial respiration if necessary and call a doctor.*

*In the event of contact with the skin, wash immediately with copious amounts of water and remove any contaminated garments.*

*In the event of contact with the eyes, rinse with clear water for 15 mins and call a doctor.*

- Do not open the circuit under any circumstances as this would loss of coolant.
- The cooling circuit contains a gas which can be dangerous under certain conditions. This gas, coolant R-134a, is colourless, odourless and heavier than air.
- The compressor has a fluid level gauge; never unscrew this gauge because it would depressurize the system. The fluid level should only be checked when draining the system.

## G - OCCASIONAL MAINTENANCE

### G1 – FUEL SYSTEM

#### BLEEDING

These operations are to be carried out only in the following cases:

- A component of the fuel system replaced.
- A drained tank.
- Running out of fuel.

**⚠ IMPORTANT ⚠**

*Fuel under high pressure that comes into contact with the skin can penetrate the skin and cause burns.*

*Spraying fuel under high pressure can cause a fire.*

*Failure to follow the inspection and maintenance instructions may result in serious injury.*

**⚠ IMPORTANT ⚠**

*Never work on the high pressure system.*

*Failure to follow this instruction may result in serious damage to the engine.*

*The high pressure fuel system must be adjusted and repaired only by approved and suitably trained technicians.*



Ensure that the level of fuel in the tank is sufficient and bleed in the following order:







- Open the engine bonnet.
- Check the condition of the fuel system.
- Operate the hand pump 1 approximately 80 times to remove air from the low pressure system.
- The I.C. engine is ready to be started up.
- Run the engine at idle for 5 minutes immediately after bleeding the fuel feed circuit, in order to ensure that the injection pump has been bled thoroughly.

NOTE: If the I.C. engine functions correctly for a short time then stops or functions irregularly, check for possible leaks in the low pressure circuit. If in doubt, contact your dealer.

**⚠ IMPORTANT ⚠**

Exhaust particle filter cleaning is an automated procedure activated by the operator when the following indicator lights are displayed:



- Park the lift truck in a safe and adequately ventilated place.
- Check the following points:
  - forward/reverse selector in neutral,
  - parking brake applied,
  - fork placed on the ground,
  - engine water temperature greater than 70 °C,
  - accelerator pedal released,
- high exhaust gas temperature indicator lamp  off.
- Check that there is sufficient fuel.
- Start the lift truck and run the engine for a few minutes to bring it up to its operating temperature.
- Press down on the top of switch 1 for more than two seconds to begin the regeneration procedure.
- The indicator lights  +  go out. If the indicator light turns on  with an audible beep to confirm that 'stationary lift truck' particle filter cleaning is running. Otherwise, if the indicator lights  +  will turn on again, with an audible beep. Double check the positioning of the lift truck and contact your manufacturer if necessary.
- The engine is running at 2000 rpm during the procedure.



**⚠ IMPORTANT ⚠**

**The exhaust particle filter regeneration procedure must only be stopped in case of necessity. The procedure will stop automatically if the operator:**

- presses the accelerator pedal,
- or select forward or reverse movement,
- or release the parking brake.

- The time taken for exhaust particle filter regeneration to complete varies (between 20 and 50 minutes) according to various criteria, such as:
  - the level of clogging of the filter,
  - the ambient temperature,
  - the fuel quality and type of engine oil,
  - the number of exhaust particle filter automatic regeneration requests previously cancelled.
- The engine will return to its normal running speed to indicate that the procedure has finished.

**⚠ IMPORTANT ⚠**

**After the exhaust particle filter regeneration procedure, let the engine idle for a few minutes to lower its temperature before switching off the ignition.**

**⚠ IMPORTANT ⚠**

*In the event of a wheel being changed on the public highway, secure the lift truck vicinity:*

- Stop the lift truck, if possible on firm, level ground.
- To pass on stop of lift truck (see: 1 - OPERATING AND SAFETY INSTRUCTIONS: DRIVING INSTRUCTIONS UNLADEN AND LADEN).
- Switch on the warning lights.
- Immobilise the lift truck in both directions on the axle opposite to the wheel to be changed.
- Unlock the nuts of the wheel to be changed.

**REAR WHEEL**

For this operation, we advise you to use the hydraulic jack MANITOU Reference 505507.

- Place the jack under the rear axle, as near as possible to the wheel and adjust the jack.
- Lift the wheel until it comes off the ground and put in place the safety block under the axle.
- Completely unscrew the wheel nuts and remove them.
- Free the wheel by reciprocating movements and roll it to the side.
- Slip the new wheel on the wheel hub.
- Hand-tighten the nuts, grease them if necessary.
- Remove the security block and lower the lift truck with the jack.
- Tighten the wheel nuts with a torque wrench (see: 3 - MAINTENANCE: A - DAILY AND EVERY 2000 HOURS OF SERVICE OR 2 YEARS for tightening torque).

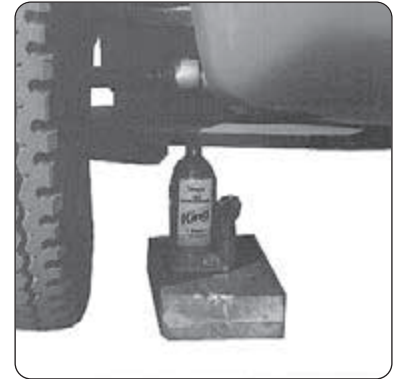
**FRONT WHEEL**

For this operation, we advise you to use the hydraulic jack MANITOU reference 505507 and the safety support MANITOU reference 554772.

- Place the jack under the flared axle tube, as near as possible to the wheel and adjust the jack.
- Lift the wheel until it comes off the ground and put in place the safety support under the frame.
- Completely unscrew the wheel nuts and remove them.
- Free the wheel by reciprocating movements and roll it to the side.
- Slip the new wheel on the wheel hub.
- Hand-tighten the nuts, grease them if necessary.
- Remove the safety support and lower the lift truck with the jack.
- Tighten the wheel nuts with a torque wrench (see: 3 - MAINTENANCE: A - DAILY AND EVERY 2000 HOURS OF SERVICE OR 2 YEARS for tightening torque).

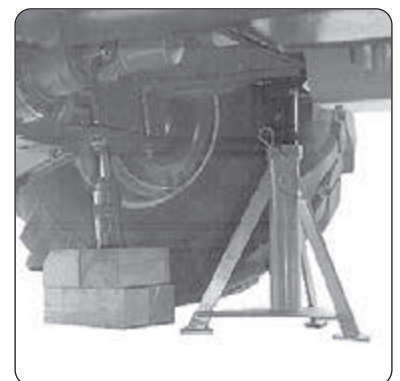

## G4 – FRONT HEADLIGHTS

### ADJUSTING

#### RECOMMENDED SETTING

(as per standard ECE-76/756 76/761 ECE20)

Set to -2 % of the dipped beam in relation to the horizontal axis of the headlamp.

#### ADJUSTING PROCEDURE

- Place the unladen lift truck in the transport position and perpendicular to a white wall on flat, level ground.
- Check the tyre pressures (see: 2 - DESCRIPTION: FRONT AND REAR TYRES).
- Place the forward/reverse selector in neutral.

#### CALCULATING THE HEIGHT OF THE DIPPED BEAM (H2)

- h1 = Height of the dipped beam in relation to the ground.
- h2 = Height of the adjusted beam.
- l = Distance between the dipped beam and the white wall.

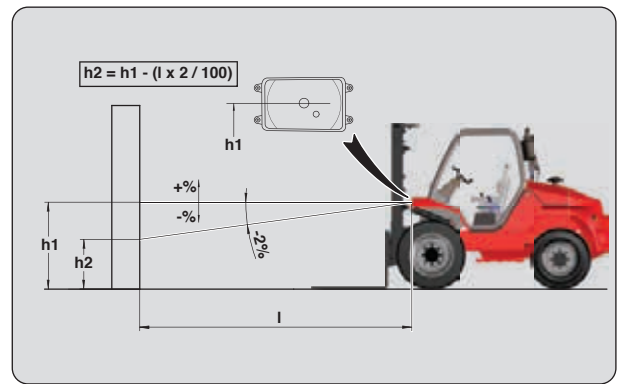

## G5 – BATTERY FAILURE

### CHANGE

#### ⚠ IMPORTANT ⚠

*Operate the battery cut-off no less than 30 seconds after having switched off the ignition with the ignition key.*

*Handling and servicing a battery can be dangerous, take the following precautions:*

- *Wear protective goggles.*
- *Keep the battery horizontal.*
- *Never smoke or work near a naked flame.*
- *Work in a well-ventilated area.*

*- In the event of electrolyte being spilled onto the skin or splashed in the eyes, rinse thoroughly with cold water for 15 minutes and call a doctor.*

- Lift out protective casing 1.
- Bring a battery of the same type as the one used for the lift truck and battery cables.
- Connect the battery while respecting the polarity.
- Start the lift truck and remove the cables as soon as the I.C engine is running.
- Change the battery 2.

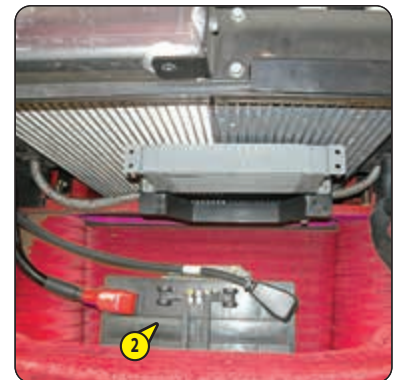

**⚠ IMPORTANT ⚠**

**Do not tow the lift truck at more than 25 Km/h.**

- Put the forward/reverse lever and the gear shift in neutral (as per the model of the lift truck).
- Release the hand brake.
- Switch on the warning lights.
- If the I.C. engine is not running there will be no steering or braking assistance. Operate the steering and pedal slowly avoiding sudden jerky movements.

**G7 – LIFT TRUCK**

**SLINGING**

- Take into account the position of the lift truck centre of gravity for lifting.

A = 1204 mm	B = 785 mm	M 26/30-2+H ST3B
A = 1204 mm	B = 785 mm	M 26/30-4+H ST3B
A = mm	B = mm	M 40/50-2+H ST3B
A = 1245 mm	B = 875 mm	M 40/50-4+H ST3B

- Place the hooks in the fastening points 1 provided.

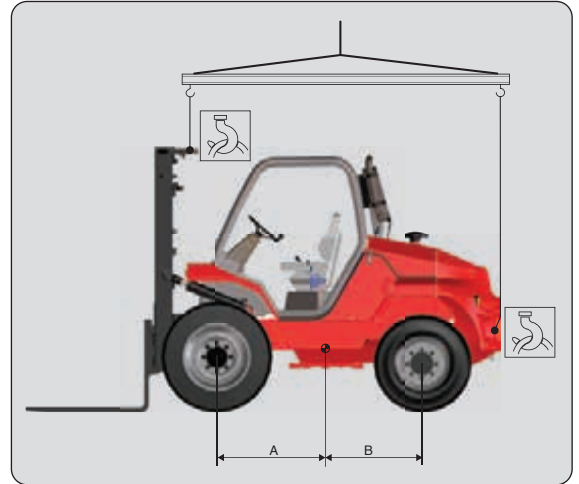

**⚠ IMPORTANT ⚠**

Ensure that the safety instructions connected to the platform are respected before the loading of the lift truck and that the driver of the means of transport is informed of the dimensions and the weight of the lift truck (see: 2 - DESCRIPTION: CHARACTERISTICS).

Ensure that the platform is of sufficient size and loading capacity for transporting the lift truck. Also check the allowable ground contact pressure of the platform relative to the lift truck.

**⚠ IMPORTANT ⚠**

For lift trucks equipped with a turbo-charged I.C. engine, block off the exhaust outlet to avoid rotation of the turbo shaft without lubrication when transporting the vehicle.

**LOADING THE LIFT TRUCK**

- Block the wheels of the platform.
- Attach the loading ramps to the platform in such a way as to give the shallowest possible ramp angle for the lift truck.
- Load the lift truck parallel to the platform.
- Shut down the lift truck (see: 1 - OPERATING AND SAFETY INSTRUCTIONS: DRIVING INSTRUCTIONS UNLADEN AND LADEN).

**STOWING THE LIFT TRUCK**

- Fix the chocks to the platform at the front and at the back of each tyre.
- Also fix the chocks to the platform on the inside of each tyre.
- Secure the lift truck to the platform with sufficiently strong ropes. To the front by passing above the articulation fittings 1 of the mast and to the back onto the towing pin 2 and to the fastening points 3.
- Tighten the ropes.

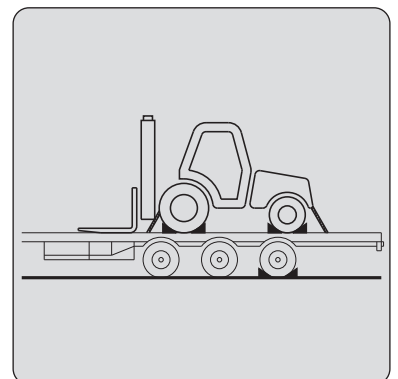
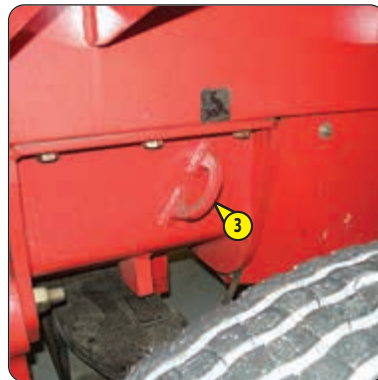
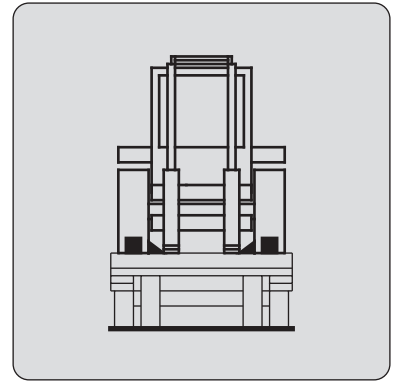
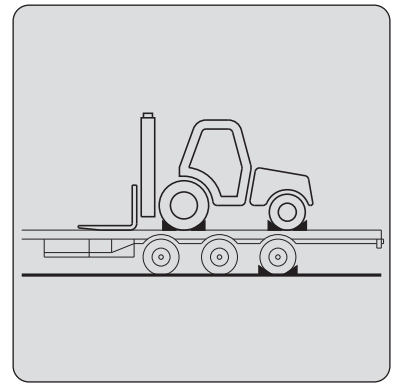

647122 (28/10/2024)  
M26/30-2 + H ST3B / M26/30-4 + H ST3B  
M40/50-2 + H ST3B / M40/50-4 + H ST3B



# ***4 - O P T I O N A L A T T A C H M E N T S F O R U S E W I T H T H E R A N G E***



# TABLE OF CONTENTS

## 4 - OPTIONAL ATTACHMENTS FOR USE WITH THE RANGE

<b><u>INTRODUCTION</u></b>	<b>5</b>
<b><u>ATTACHMENT TECHNICAL CHARACTERISTICS</u></b> M 26/30-2+H ST3B    M 26/30-4+H ST3B	<b>6</b>
<b><u>ATTACHMENT TECHNICAL CHARACTERISTICS</u></b> M 40/50-2+H ST3B    M 40/50-4+H ST3B	<b>10</b>
<b><u>ATTACHMENT SHIELDS</u></b>	<b>12</b>



## INTRODUCTION

- Your lift truck must be used with interchangeable equipment. These items are called: ATTACHMENTS.
- A wide range of attachments is available, guaranteed by MANITOU and designed to fit your lift truck perfectly.

### **⚠ IMPORTANT ⚠**

*Only attachments approved by MANITOU are to be used on our lift trucks  
(see: 4 - ADAPTABLE ATTACHMENTS IN OPTION ON THE RANGE: TECHNICAL SPECIFICATIONS OF ATTACHMENTS).  
The manufacturer shall not be liable for any modification or adaptation of an attachment made without its knowledge.*

- The attachments are delivered with a load chart concerning your lift truck. The operator's manual and the load chart should be kept in the places provided in the lift truck. For standard attachments, their use is governed by the instructions contained on this notice.

### **⚠ IMPORTANT ⚠**

*Maximum loads are defined by the capacity of a lift truck taking account of the attachment's mass and centre of gravity.  
In the event of the attachment having less capacity than the lift truck, never exceed this limit.*

- Some particular uses require the adaptation of the attachment which is not provided in the price-listed options. Optional solutions exist, consult your dealer.

## SUSPENDED LOAD

### **⚠ IMPORTANT ⚠**

*Suspended loads **MUST** be handled with a lift truck designed for that purpose  
(see: 1 - OPERATING AND SAFETY INSTRUCTIONS: LOAD HANDLING INSTRUCTIONS: H - TAKING-UP AND SETTING-DOWN A SUSPENDED LOAD).*

## STANDARDISED SIDE-SHIFT CARRIAGE

\* : Double Mast With All-Round Vision

\*\* : Double mast with free-acting lift

\*\*\* : Triple mast with free-acting lift

\*\*\*\* : Triple mast without free-acting lift

	TDL 100E-SS-B686 - 1470	TDL 100E-SS-E089 - 1750	TDL 100E-SS-E160 - 2000
<b>PART NUMBER</b>	<b>570218*</b>	<b>570073*</b>	<b>570074*</b>
	<b>570166**</b>	<b>570167**</b>	<b>570168**</b>
	<b>570169***</b>	<b>570170***</b>	<b>570171***</b>
	<b>570163****</b>	<b>570164****</b>	<b>570165****</b>
Rated capacity	3000 kg	3000 kg	3000 kg
Side-shift	2 x 100 mm	2 x 100 mm	2 x 100 mm
Width	1470 mm	1750 mm	2000 mm
Mass	192 kg	219 kg	240 kg

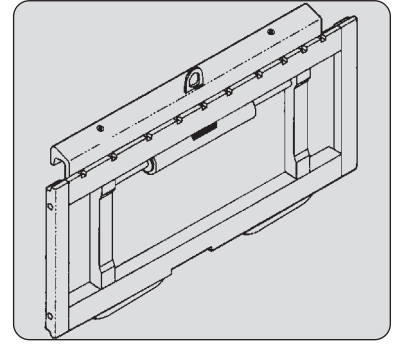

## STANDARDISED FORK

	<b>415727</b>	<b>415729</b>
<b>PART NUMBER</b>		
Section	125 x 40 x 1200 mm	125 x 45 x 1200 mm
Mass	74 kg	79 kg

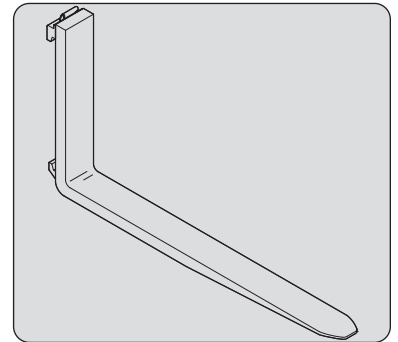

## LOAD BACK REST

	<b>555325</b>	<b>570113</b>	<b>570114</b>
<b>PART NUMBER</b>			
Width	1470 mm	1750 mm	2000 mm
Mass	41 kg	46 kg	51 kg

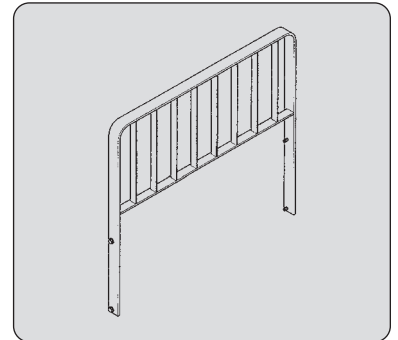

## DIGGING BUCKET

	SP 500 30N AD S3	SP 500 30NL AD S3
<b>PART NUMBER</b>	<b>741444</b>	<b>741446</b>
Rated capacity	500 L/900 kg	500 L/900 kg
Width	1648 mm	2022 mm
Teeth	4	6
Mass	420 kg	450 kg

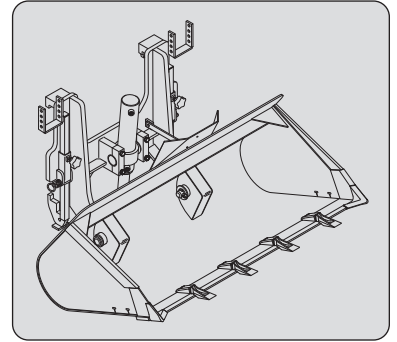

## DIGGING BUCKET

	SP 700 40N AD S2	SP 1000 40NL AD S2
<b>PART NUMBER</b>	<b>751454</b>	<b>751459</b>
Rated capacity	700 L/1260 kg	1000 L/1800 kg
Width	2110 mm	2210 mm
Teeth	6	6
Mass	630 kg	715 kg

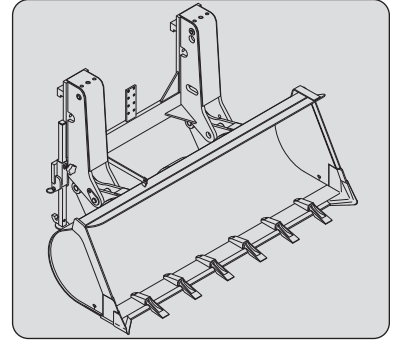

## LOADING BUCKET

	SP 500 30N SD	SP 500 30NL SD
<b>PART NUMBER</b>	<b>570278</b>	<b>570280</b>
Rated capacity	500 L/900 kg	500 L/900 kg
Width	1648 mm	2022 mm
Mass	420 kg	450 kg

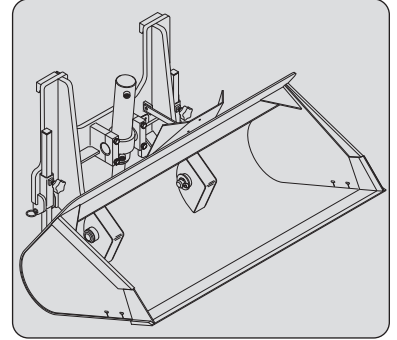

## LOADING BUCKET

	SP 500 30N SD	SP 500 30NL SD
<b>PART NUMBER</b>	<b>570278</b>	<b>570280</b>
Rated capacity	500 L/900 kg	500 L/900 kg
Width	1648 mm	2022 mm
Mass	420 kg	450 kg

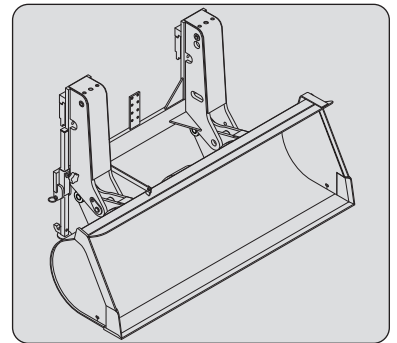

## ARGICULTURAL BUCKET

	BA 1000 S2 30N	BA 1500 S2 30N	BA 2000 S2 30N
<b>PART NUMBER</b>	<b>751466</b>	<b>751467</b>	<b>751468</b>
Rated capacity	1000 L/1200 kg	1500 L/1800 kg	2000 L/2000 kg
Width	2022 mm	2022 mm	2022 mm
Mass	480 kg	610 kg	700 kg

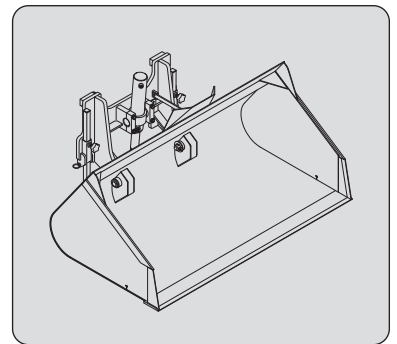

## CEREAL AND FERTILIZER BUCKET

	<b>PART NUMBER</b>	<b>BCE 1500 40N</b>	<b>BCE 2000 40N</b>
Rated capacity	<b>751469</b>	2000 L/2400 kg	2000 L/2400 kg
Width		2100 mm	2100 mm
Mass		775 kg	870 kg

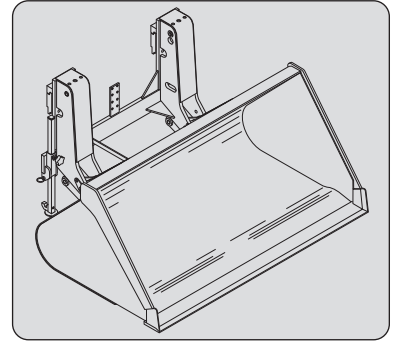

### CONCRETE BUCKET (ADAPTABLE ON FORKS)

<b>PART NUMBER</b>	<b>BB 500 S4</b> <b>654409</b>
Rated capacity	500 L/1300 kg
Width	1100 mm
Mass	205 kg

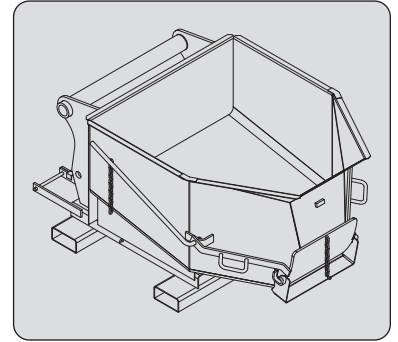

### CONCRETE BUCKET WITH SPOUT (ADAPTABLE ON FORKS)

<b>PART NUMBER</b>	<b>BBG 500 S4</b> <b>654411</b>
Rated capacity	500 L/1300 kg
Width	1100 mm
Mass	220 kg

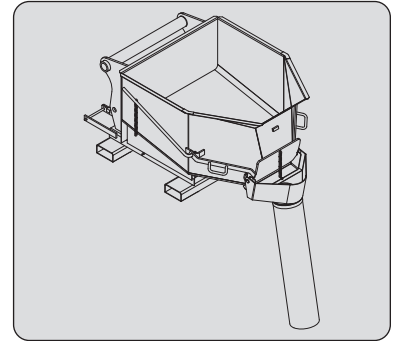

### SPOUT BUCKET (ADAPTABLE ON FORKS)

<b>PART NUMBER</b>	<b>GL 300 S2</b> <b>174371</b>	<b>GL 400 S2</b> <b>174372</b>
Rated capacity	300 L/725 kg	400 L/969 kg
Mass	150 kg	166 kg

HYDRAULIC KIT TO OPEN THE SPOUT  
**PART NUMBER 653750**

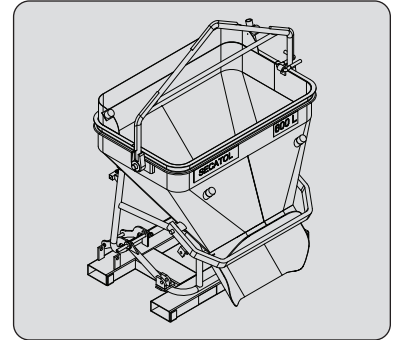

### SPOUT BUCKET (ADAPTABLE ON FORKS)

<b>PART NUMBER</b>	<b>GL 600 S2</b> <b>174373</b>	<b>GL 800 S2</b> <b>174374</b>
Rated capacity	600 L/1440 kg	800 L/1920 kg
Mass	290 kg	325 kg

HYDRAULIC KIT TO OPEN THE SPOUT  
**PART NUMBER 653750**

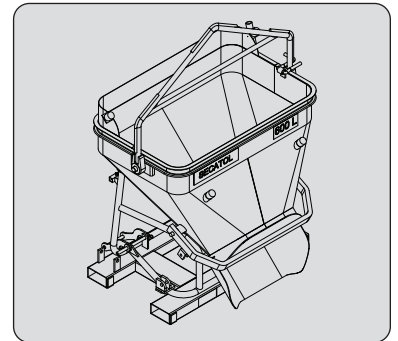

### SPOUT BUCKET (ADAPTABLE ON FORKS)

<b>PART NUMBER</b>	<b>GL 1000 S2</b> <b>174375</b>	<b>GL 1500 S2</b> <b>174376</b>
Rated capacity	1000 L/2440 kg	1500 L/3591 kg
Mass	360 kg	409 kg

HYDRAULIC KIT TO OPEN THE SPOUT  
**PART NUMBER 653750**

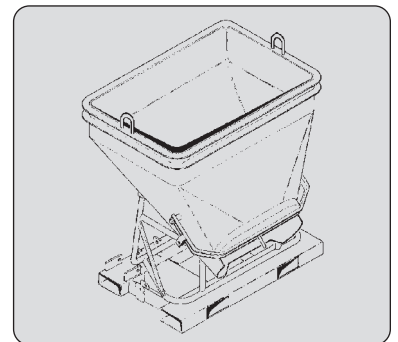

## STANDARDISED SIDE-SHIFT CARRIAGE

\* : Double Mast With All-Round Vision

\*\* : Double mast with free-acting lift

	TDL 50N 1670	TDL 50N 2000
<b>PART NUMBER</b>	<b>752187*</b>	<b>752188*</b>
	<b>572070**</b>	<b>572072**</b>
Rated capacity	4500 kg	4500 kg
Side-shift	2 x 100 mm	2 x 100 mm
Width	1670 mm	2000 mm
Mass	360 kg	415 kg

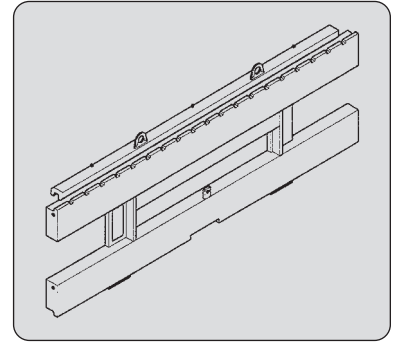

## STANDARDISED FORK

	415499	415746
<b>PART NUMBER</b>	<b>415499</b>	<b>415746</b>
Section	150 x 60 x 1200 mm	125 x 40 x 1200 mm
Mass	138 kg	70 kg

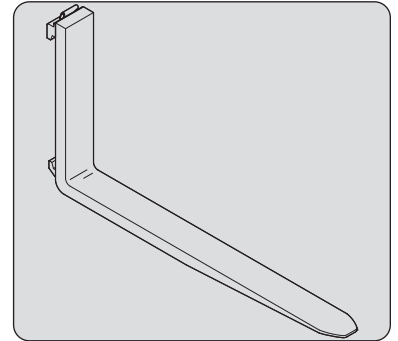

## LOAD BACK REST

	572788	572790
<b>PART NUMBER</b>	<b>572788</b>	<b>572790</b>
Width	1670 mm	2000 mm
Mass	56 kg	63 kg

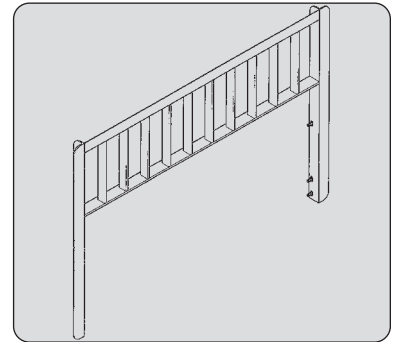

## STANDARD DOUBLE SIDE-SHIFT CARRIAGE

	DOUBLE TDLA 50N
<b>PART NUMBER</b>	<b>572404</b>
Rated capacity	2 x 2500 kg
Side-shift	2 x 150/100 mm
Width	2 x 985 mm
Mass	2 x 165 kg

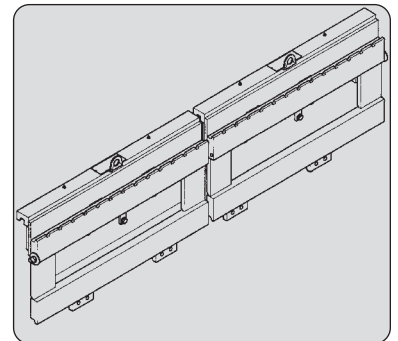

## DIGGING BUCKET

	<b>SP 700 50N AD S2</b>	<b>SP 1000 50NL AD S2</b>
<b>PART NUMBER</b>	<b>751455</b>	<b>751460</b>
Rated capacity	700 L/1260 kg	1000 L/1800 kg
Width	2110 mm	2210 mm
Teeth	6	6
Mass	605 kg	690 kg

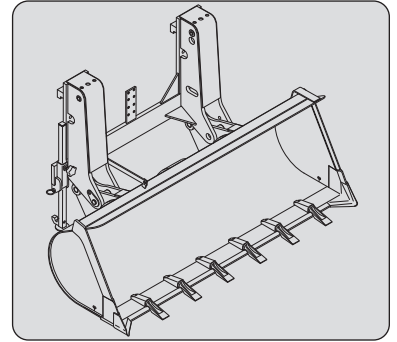

## LOADING BUCKET

	<b>SP 700 50N SD</b>	<b>SP 1000 50N SD</b>
<b>PART NUMBER</b>	<b>751453</b>	<b>751457</b>
Rated capacity	700 L/1260 kg	1000 L/1800 kg
Width	2100 mm	2200 mm
Mass	5800 kg	665 kg

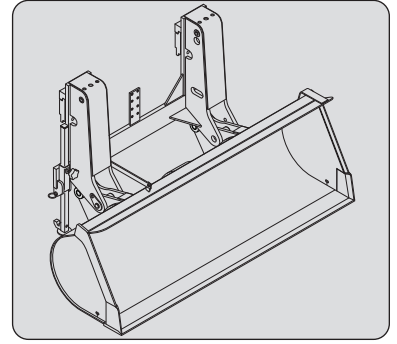

## AGRICULTURAL BUCKET

	<b>BA 1000 S2 30N</b>	<b>BA 1500 S2 30N</b>	<b>BA 2000 S2 30N</b>
<b>PART NUMBER</b>	<b>751466</b>	<b>751467</b>	<b>751468</b>
Rated capacity	1000 L/1200 kg	1500 L/1800 kg	2000 L/2000 kg
Width	2022 mm	2022 mm	2022 mm
Mass	480 kg	610 kg	700 kg

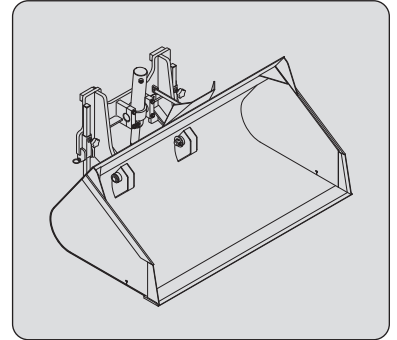

## CEREAL AND FERTILIZER BUCKET

	<b>BCE 1500 50N</b>	<b>BCE 2000 50N</b>	<b>BCE 2500 50N</b>
<b>PART NUMBER</b>	<b>751470</b>	<b>751472</b>	<b>751474</b>
Rated capacity	1500 L/1800 kg	2000 L/2400 kg	2500 L/3000 kg
Width	2100 mm	2100 mm	2100 mm
Mass	750 kg	845 kg	925 kg

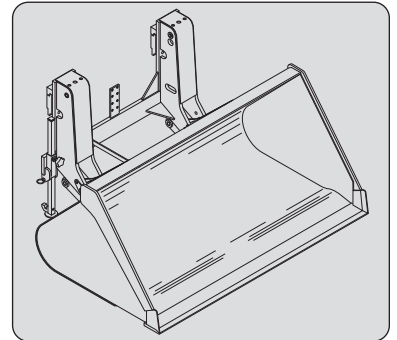

## SPOUT BUCKET (ADAPTABLE ON FORKS)

	<b>GL 600 S2</b>	<b>GL 800 S2</b>
<b>PART NUMBER</b>	<b>174373</b>	<b>174374</b>
Rated capacity	600 l/1440 kg	800 l/1920 kg
Mass	290 kg	325 kg
<b>HYDRAULIC KIT TO OPEN THE SPOUT</b>		
<b>PART NUMBER</b>	<b>653750</b>	

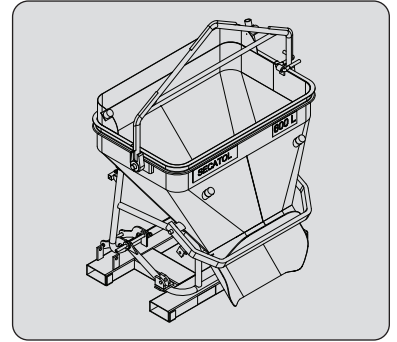

## SPOUT BUCKET (ADAPTABLE ON FORKS)

	<b>GL 1000 S2</b>	<b>GL 1500 S2</b>
<b>PART NUMBER</b>	<b>174375</b>	<b>174376</b>
Rated capacity	1000 l/2200 kg	1500 l/3300 kg
Mass	325 kg	375 kg
<b>HYDRAULIC KIT TO OPEN THE SPOUT</b>		
<b>PART NUMBER</b>	<b>653750</b>	

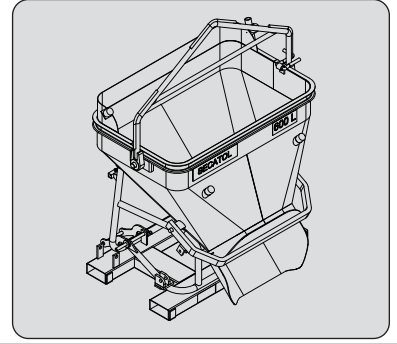

# ATTACHMENT SHIELDS

## FORK PROTECTOR

PART NUMBER 227801

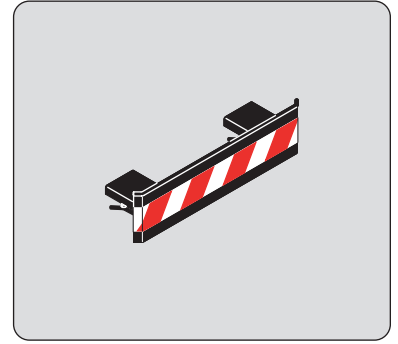

## BUCKET PROTECTOR

*Always ensure that the width of the protector you choose is less than or equal to the width of the bucket.*

	<b>PART NUMBER</b>	<b>206734</b>	<b>206732</b>	<b>206730</b>
Width		1375 mm	1500 mm	1650 mm
	<b>PART NUMBER</b>	<b>235854</b>	<b>206728</b>	<b>206726</b>
Width		1850 mm	1950 mm	2000 mm
	<b>PART NUMBER</b>	<b>223771</b>	<b>223773</b>	<b>206724</b>
Width		2050 mm	2100 mm	2150 mm
	<b>PART NUMBER</b>	<b>206099</b>	<b>206722</b>	<b>223775</b>
Width		2250 mm	2450 mm	2500 mm

