



**647909EN-USM4A112020**

160 ATJ 4RD ST5 S2  
160 ATJ RC 4RD ST5 S2  
180 ATJ 4RD ST5 S2  
180 ATJ RC 4RD ST5 S2

**OPERATOR'S MANUAL**  
*(ORIGINAL MANUAL)*



INITIAL VERSION	A112020
UPDATED	

*This brochure is provided for information purposes only. Any reproduction, copy, declaration, recording, transfer, distribution or other, in whole or in part, in any format whatsoever, is prohibited. The plans, drawings, views, comments and instructions, as well as the organization of the document, are the intellectual property of MANITOU BF. Any violation of the aforementioned may lead to civil and criminal prosecution. The logos as well as the visual identity of the company belong to MANITOU BF and may not be used without express and formal authorization. All rights reserved.*

**Clause regarding database usage restrictions**

*Connected Manitou machines are equipped with boxes that collect technical data on the machines (such as geo-tracking data or data on component operation). This data, which is organized, processed and enhanced by algorithms and expertise proprietary to Manitou, constitutes a protected database under article L.341-1 of the Intellectual Property Code.*

*It is strictly forbidden to have access to all or part of this database and to use the data (including in the event of accidental access) without explicit prior authorization from Manitou. In the event that Manitou authorizes a Manitou machine user to access all or part of this database, Manitou, as producer of this database, cedes to the user only a right to personal, non-exclusive, nontransferable use of the database, and only by access to an information technology platform hosted by a server owned or controlled by Manitou.*

*In any case, the following are strictly prohibited:*

- any extraction, reproduction, representation, reuse through provision to the public, distribution, transfer, permanent or temporary, on any medium, by any means, and in any form whatsoever, of all or of a qualitatively or quantitatively substantial part of the contents of this database.*
- any extraction, reproduction, representation, reuse through provision to the public, distribution, transfer, repeated or systematic of qualitatively or quantitatively insubstantial parts of the content of the database during operations manifestly exceeding normal use of the database by the user of the machine for his own needs,*
- any use of means to bypass technical protection measures for databases or software source code embedded in the boxes, in keeping with article L.331-5 of the Intellectual Property Code.*

## FOREWORD

### **ABOUT THIS OPERATOR'S MANUAL**

---

This operator's manual forms an integral part of this machine and must be kept in the platform's storage compartment at all times.

MANITOU reserves the right to change its models and their equipment without notice. Contact MANITOU for up-to-date information.

This operator's manual provides operators with all the information relating to the safety precautions, usage instructions and maintenance procedures to ensure safe and reliable use of this machine.

Carefully read and understand this instruction manual before using this machine.

This manual has been produced based on the equipment list and technical specifications given at the time of its design. The level of equipment depends on the options chosen and the country of sale.

According to the options and the date of sale, certain items of equipment/functions described in this operator's manual may not be present on the machine.

Descriptions and illustrations are non binding.

### **ANTICIPATED USE**

---

This machine is a mobile aerial work platform of the type 3b designed to transport and lift personnel and their tools and equipment to a workplace at height.

MANITOU has ensured that this machine is suitable for use in the standard operating conditions defined in this operator's manual.

### **TECHNICAL INFORMATION BULLETINS**

---

The safety of the machine and personnel is essential for MANITOU. The technical information bulletins are written to communicate important safety information, intended for dealers, owners and users of the machine.

This machine must comply with all the relevant technical information bulletins. Contact MANITOU or your dealer to get information on the bulletins concerning your machine.

These technical information bulletins are sent to the owners of the machine. As a result, it is very important to register your machine and ensure that the information is accurate and up to date.

In the event of transfer of ownership of the machine, update the information to guarantee that the technical information bulletins are sent to the new owner.

## **CONTACT THE MANUFACTURER**

---

You should contact MANITOU in the following scenarios:

- To report an accident.
- To update the information relating to the current owner.
- For questions about compliance with standards and regulations.
- For questions about machine use and safety.
- For questions about any special application or any modification of the product.

*Manitou BF S.A Limited liability company with a Board of Directors.*

*Headquarters : 430 rue de l'Aubinière - 44150 Ancenis - France*

*Share capital: €39,548,949*

*Entered in the Nantes Trade and Companies Register under No. 857 802 508.*

*Tel.: +33 (0)2 40 09 10 11*

*www.manitou.com*

## **WARNINGS AND SAFETY INSTRUCTIONS**

---

The following safety alert is used in this manual to warn you of the risks during use or maintenance of this machine:



Follow the safety instructions following this warning to avoid any risk of injury, death or equipment damage.

## IDENTIFICATION OF THE MACHINE

The machine's identification plate is riveted to the inside left-hand side of the turntable. The following information is engraved on it:

Designation	
Year of manufacture	
Model year	
Unladen mass	
Nominal power	
Voltage	
Inside / Outside	
Maximum load	
Maximum number of persons	
Mass of equipment	
Manual forces	
Maximum inclination	
Maximum wind speed	
Serial Number	

Note: commercial names are used in this operator's manual in order to make it easier to read.

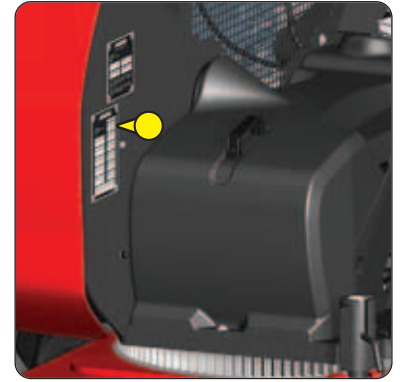

The EWP additional information plate is riveted to the inside left-hand side of the turntable. The following information is engraved on it:

Designation	
Year of manufacture	
Model year	
Unladen mass	

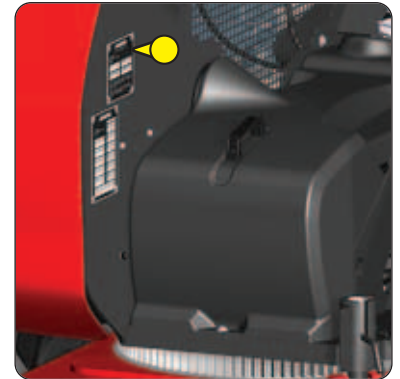

**160 ATJ 4RD ST5 S2**  
**160 ATJ RC 4RD ST5 S2**

Commercial name: 160 ATJ



**180 ATJ 4RD ST5 S2**  
**180 ATJ RC 4RD ST5 S2**

Commercial name: 180 ATJ



## SECTIONS

- 1 - OPERATING AND SAFETY INSTRUCTIONS**
- 2 - DESCRIPTION**
- 3 - MAINTENANCE**



# ***1 - OPERATING AND SAFETY INSTRUCTIONS***

# 1 - OPERATING AND SAFETY INSTRUCTIONS

## INSTRUCTIONS TO THE COMPANY MANAGER

1-4

THE SITE . . . . .	1-4
THE OPERATOR . . . . .	1-4
THE MACHINE . . . . .	1-4
A - SUITABILITY OF THE MACHINE FOR THE TASK . . . . .	1-4
B - ADAPTING THE MACHINE TO USUAL ENVIRONMENTAL CONDITIONS . . . . .	1-5
C - MODIFYING THE MACHINE . . . . .	1-5
INSTRUCTIONS . . . . .	1-5
MAINTENANCE . . . . .	1-5

## INSTRUCTIONS FOR THE OPERATOR

1-6

INTRODUCTION . . . . .	1-6
GENERAL INSTRUCTIONS . . . . .	1-6
A - OPERATOR'S MANUAL . . . . .	1-6
B - AUTHORISATION FOR USE IN FRANCE . . . . .	1-6
C - MAINTENANCE . . . . .	1-7
D - MODIFYING THE MACHINE . . . . .	1-7
E - GROUND LINK . . . . .	1-7
F - SAFETY DEVICES . . . . .	1-7
OPERATING INSTRUCTIONS . . . . .	1-8
A - BEFORE USING THE MACHINE . . . . .	1-8
B - DRIVER'S CAB LAYOUT . . . . .	1-8
C - ENVIRONMENT . . . . .	1-9
D - VISIBILITY . . . . .	1-17
E - STARTING MACHINES WITH A DIESEL ENGINE . . . . .	1-17
F - SWITCHING ON ELECTRICAL MACHINES . . . . .	1-17
G - DRIVING THE MACHINE . . . . .	1-17
H - SHUTTING DOWN THE MACHINE . . . . .	1-18
INSTRUCTIONS FOR WELDING AND BLOW TORCH WORK ON AN EXTERNAL STRUCTURE . . . . .	1-19
A - WITH AN ELECTRICAL WELDING SET . . . . .	1-19
B - WITH A BLOW TORCH . . . . .	1-19

## MACHINE MAINTENANCE INSTRUCTIONS

1-20

GENERAL INSTRUCTIONS . . . . .	1-20
MAINTENANCE . . . . .	1-20
MAINTENANCE LOGBOOK . . . . .	1-20
LUBRICANT AND FUEL LEVELS . . . . .	1-20
HYDRAULICS . . . . .	1-20
ELECTRICITY . . . . .	1-21
TILT SENSOR . . . . .	1-21
WELDING ON THE MACHINE . . . . .	1-21
WASHING THE MACHINE . . . . .	1-21

***IF THE MACHINE IS NOT TO BE USED FOR A LONG TIME*** **1-22**

---

INTRODUCTION . . . . . 1-22

PREPARATION OF THE MACHINE . . . . . 1-22

MACHINES WITH A DIESEL ENGINE: ENGINE PROTECTION . . . . . 1-22

ELECTRICAL MACHINES: BATTERY CHARGE . . . . . 1-22

PROTECTING THE MACHINE . . . . . 1-22

BRINGING THE MACHINE BACK INTO SERVICE. . . . . 1-23

***DISPOSING OF THE MACHINE*** **1-24**

---

RECYCLING OF MATERIALS . . . . . 1-24

    METALS . . . . . 1-24

    PLASTICS . . . . . 1-24

    RUBBER . . . . . 1-24

    GLASS . . . . . 1-24

ENVIRONMENTAL PROTECTION. . . . . 1-24

    WORN OR DAMAGED PARTS . . . . . 1-24

    USED OIL . . . . . 1-24

    USED BATTERIES. . . . . 1-24

## INSTRUCTIONS TO THE COMPANY MANAGER

### THE SITE

Proper management of the machine's area of travel will reduce the risk of accidents:

- Ground not unnecessarily uneven or obstructed.
- No excessive slopes.
- Pedestrian traffic controlled, etc.

### THE OPERATOR

#### **⚠ IMPORTANT ⚠**

*Only qualified, authorised personnel can use this machine.*

*This authorisation is given in writing by the appropriate person in the establishment with respect to the use of machine and must be carried permanently by the operator.*

#### **⚠ IMPORTANT ⚠**

*On the basis of experience, there are a number of possible situations in which operating the machine is contra-indicated.*

*Such foreseeable abnormal uses, the main ones being listed below, are strictly forbidden:*

- *The foreseeable abnormal behaviour resulting from ordinary negligence, but which does not result from any wish to put the machinery to any improper use.*
  - *The reflex reactions of a person in the event of a malfunction, incident, fault, etc. during operation of the machine.*
    - *Behaviour resulting from application of the "principle of least effort" when performing a task.*
- *The foreseeable behaviour of such persons as: apprentices, teenagers, handicapped persons, trainees tempted to drive a machine, operators tempted to operate a machine to win a bet, in competition or for their own personal experience.*
  - *The person in charge of the establishment must take these criteria into account when assessing the suitability of a person to drive.*

#### **⚠ IMPORTANT ⚠**

**OBTAIN INFORMATION ON:**

- *How to behave when there is a fire.*
- *The location of the nearest first aid kit and fire extinguisher.*
- *The emergency telephone numbers for calling (the doctors, ambulance, hospital and fire brigade).*

### THE MACHINE

#### **A - SUITABILITY OF THE MACHINE FOR THE TASK**

- MANITOU has ensured that this machine is suitable for use under the standard operating conditions defined in this operator's manual, with an **OVERLOAD TEST COEFFICIENT OF 1.25** and an **OPERATIONAL TEST COEFFICIENT OF 1.1**, as stipulated in harmonised standard **EN 280** for **MEWPs** (Mobile Elevating Work Platforms).
- Before commissioning, the company manager must make sure that machine is appropriate for the work to be done, and perform certain tests (in accordance with current legislation).

## B - ADAPTING THE MACHINE TO USUAL ENVIRONMENTAL CONDITIONS

### **⚠ IMPORTANT ⚠**

*For operation under average climatic conditions, i.e.: between -15 °C and +35 °C, lubricants are topped up in the factory.*

*For operation under more severe climatic conditions, before starting up, it is necessary to drain all the circuits, then ensure correct levels of lubricants using lubricants properly suited to the relevant ambient temperatures. The same applies to coolant.*

### **⚠ IMPORTANT ⚠**

*Machines with diesel engines are designed for outdoor use under normal atmospheric conditions and indoor use in suitably aerated and ventilated premises.*

*Electrical machines are designed for outdoor use under normal atmospheric conditions and for indoor use.*

*It is prohibited to use the machine in areas where there is a risk of fire or which are potentially explosive (e.g. refineries, fuel or gas depots, stores of inflammable products, etc.).*

*For use in these areas, specific equipment is available, consult your dealer.*

- In addition to standard equipment mounted on your machine, many options are available, such as: rotating beacon light, worklight, etc. Contact your dealer.
- Take the climate and atmospheric conditions of the site of use into account. Consult your dealer for adapting the lubricants and frost protection.
- Prevent fire risks associated with use in dusty and flammable conditions.
- A machine operating in an area without fire extinguishing equipment must be equipped with an individual extinguisher. Solutions are available, consult your dealer.

## C - MODIFYING THE MACHINE

### **⚠ IMPORTANT ⚠**

*It is strictly prohibited to replace machine components with components not approved by Manitou (batteries, wheels, platform, etc.).*

### **⚠ IMPORTANT ⚠**

*It is strictly forbidden to change the structure and settings of the various components of your machine (hydraulic pressure, calibrating limiters, engine speed, sensors, addition of extra equipment, addition of counterweight, unapproved attachments, alarm systems, etc.) yourself. In this event, the manufacturer cannot be held responsible.*

### **⚠ IMPORTANT ⚠**

*Risk of the machine becoming unstable:*

- *Depending on the model, your machine may be supplied with standard wheels or all-terrain wheels. It is PROHIBITED to change from one type of wheel to the other.*
- *ELECTRICAL MACHINES: it is prohibited to replace the batteries with lighter batteries.*

## INSTRUCTIONS

---

- The instruction manual should always be in good condition, in the operator's language and placed in the platform storage compartment.
- You must replace the instruction manual, as well as any plates or stickers, if they are no longer legible or are missing or damaged.

## MAINTENANCE

---

### **⚠ IMPORTANT ⚠**

*Refer to chapter: MACHINE MAINTENANCE INSTRUCTIONS.*

### **⚠ IMPORTANT ⚠**

*Your machine must be periodically inspected to ensure its continued compliance.*

*The inspection frequency is defined by the legislation in force in the country in which the machine is used.*

- Maintenance or repairs other than those detailed in section 3 - MAINTENANCE must be carried out by qualified personnel (consult your dealer) and under the necessary safety conditions to maintain the health of the operator and any third party.
- Example for France: the manager in charge of the establishment using a machine must open and maintain a maintenance log for each machine (order of 2 March 2004).

# INSTRUCTIONS FOR THE OPERATOR

## INTRODUCTION

### **⚠ IMPORTANT ⚠**

*The risk of accident while using, servicing or repairing this machine can be reduced if you follow the safety instructions and preventive measures detailed in these instructions.*

*Failure to respect the safety and operating instructions, or the instructions for repairing or servicing this machine may lead to serious, even fatal accidents.*

- Only the operations and manoeuvres described in this operator's manual must be performed. The manufacturer cannot predict all possible risky situations. Consequently, the safety instructions given in the operator's manual and on the machine itself are not exhaustive.
- As an operator, you must at all times give reasonable consideration to the possible risks to yourself, to others or to the machine itself when you use it.

## GENERAL INSTRUCTIONS

### A – OPERATOR'S MANUAL

#### **⚠ IMPORTANT ⚠**

*Carefully read and understand this instruction manual before using this machine.*

- The instruction manual should always be in good condition, in the operator's language and placed in the platform storage compartment.
- You must replace the instruction manual, as well as any plates or stickers, if they are no longer legible or are missing or damaged.
- Any operations or manoeuvres not described in the operator's manual are forbidden.
- Follow the safety advice and the instructions on the machine's stickers.
- As a safety precaution, a user must be present on the ground when the machine is in use.
- Familiarise yourself with the machine on the terrain where it will be used.
- The machine must also be used in accordance with good engineering practice.
- Do not use the machine if the wind speed is over 45 km/h (12.5 m/s).
- Do not push or pull similar structures or elements off the platform. The maximum manual force is indicated in 2 - INSTRUCTIONS: SPECIFICATIONS and on 1 or more stickers located in the platform.
- Machines intended exclusively for indoor use must not be used outside the buildings.

### B - AUTHORISATION FOR USE IN FRANCE

*(or see current legislation in other countries).*

- This machine is not type-approved for driving on public roads.
- Only qualified, authorised personnel can use the machine. This authorisation is given in writing by the appropriate person in the establishment where the machine is to be used and must be carried permanently by the operator.
- The operator is not empowered to authorise the driving of the machine by another person.

## C - MAINTENANCE

### **⚠ IMPORTANT ⚠**

*Do not use the machine if the wheels are damaged or excessively worn, because this could put your own safety or that of others at risk, or cause damage to the machine itself.*

### **⚠ IMPORTANT ⚠**

*For electrical machines, the operator must ensure that:*

*- Safety goggles are always worn when charging the batteries.*

*- The batteries are not charged in an explosive environment.*

*- There is no smoking and no naked flame directed towards the batteries when they are being handled (removal/installation) and when monitoring filling levels.*

*- Do not leave the battery charger connected during a lightning storm.*

- The operator must carry out the daily maintenance (↖ 3 - MAINTENANCE) before using the machine in his place of work.
- The operator must immediately advise his superior if his machine is not in good working order or does not comply with the safety notice.
- The operator is prohibited from carrying out any repairs or adjustments himself, unless he has been trained for this purpose. He must keep the machine properly cleaned if this is among his responsibilities.
- The operator is responsible for deciding and adjusting the frequency of cleaning needed to prevent the risk of fire ensuing from the build-up of flammable material. The operator should pay special attention to all the areas of the machine where these risk materials are likely to accumulate.
- The operator must ensure that the wheels are appropriate for the type of ground (see the ground contact area of the wheels ↖ 2 - DESCRIPTION: SPECIFICATIONS). Optional solutions are available, consult your dealer.

## D - MODIFYING THE MACHINE

- ↖ INSTRUCTIONS TO SITE MANAGER: ↖ C - MODIFYING THE MACHINE.

## E - GROUND LINK

- MACHINES WITHOUT OSCILLATING AXLE (ACCORDING TO MODEL)

### **⚠ IMPORTANT ⚠**

*The frame is rigid, so the machine can bear on only three wheels.*

- MACHINES WITH OSCILLATING AXLE (ACCORDING TO MODEL)

### **⚠ IMPORTANT ⚠**

*The oscillating axle enables the machine to bear on four wheels when in transport position (within the limits of the axle's oscillation).*

*When moving in the working position, the oscillating axle is locked (the frame is stiff) so the machine may bear on only three wheels.*

## F - SAFETY DEVICES

- This machine is fitted with special safety devices that are able to limit its operation as circumstances require (↖ 2 - DESCRIPTION):
  - Excessive load in the platform.
  - Tilting of the frame beyond the authorised limits.
  - Blocking of the oscillating axle (according to model).
  - Slack or broken telescope cable (according to model).

## OPERATING INSTRUCTIONS

---

### A - BEFORE USING THE MACHINE

- Perform the daily maintenance (☞ 3 - MAINTENANCE).

### B - DRIVER'S CAB LAYOUT

- Whatever their experience, operators are advised to familiarise themselves with the position and operation of the control panels before putting the machine into operation.
- Do not get into or out of the platform until it is fully lowered.
- Always get into and out of the platform through the gate or using the sliding mid-rails (depending on the model).
- Always get in and out of the platform facing into the platform.
- Always use both hands and one foot or both feet and one hand to get in and out of the platform.
- Make sure that the sliding mid-rails (depending on the model) are in the low position and that the the gate is closed properly (depending on the model) before using this machine.
- Do not attach the sliding mid-rails in the high position.
- MANITOU strongly recommends wearing a safety harness attached to a lashing point in the platform, ☞ 2 - DESCRIPTION. Wearing a safety harness or other personal fall protection may be mandatory, comply with the local, government and national regulations in force, the employer's safety rules and the rules for work sites.
- The safety harness or other personal fall protection must comply with the local, government and national regulations in force. They must be inspected in accordance with the regulations in force.
- Safety helmets must be worn.
- Wear suitable clothing for driving the machine; do not wear baggy clothes.
- Never operate the machine when hands or feet are wet or soiled with greasy substances.
- Make sure you have the appropriate protective equipment for the job to be done.
- Prolonged exposure to high noise levels may cause hearing problems. It is recommended to wear ear muffs to protect against excessive noise.
- Remain alert at all times when using the machine. Do not listen to the radio or music using headphones or earphones.
- The operator must always be in the normal operator's position. It is prohibited to have arms or legs, or generally any part of the body, protruding from the platform.
- The control units must never in any event be used for any other than their intended purposes (e.g. for getting in or out of the platform, as a coat hook, etc.).
- The machine must not be fitted with unauthorised attachments that increase the unit's wind load.
- Do not use ladders or improvised structures in the platform to gain extra height.
- Do not climb onto the platform railings to gain extra height.

## C - ENVIRONMENT

### **⚠ IMPORTANT ⚠**

*If the platform must remain stationary over a structure for a long period, there is a risk that the platform will descend and rest on this structure because of the oil cooling in the cylinders or a minor leak in the cylinder locking system. To eliminate this risk:*

- Regularly check the distance between the platform and the structure and readjust if necessary.
- If possible use the machine at an oil temperature as close as possible to ambient temperature.

### **⚠ IMPORTANT ⚠**

*It is forbidden to use the machine close to electricity cables. Maintain the specified safe distances, refer to 5.8 WORKING IN PROXIMITY TO AERIAL CONDUCTORS (OVERHEAD POWER LINES) on the next pages.*

*You must consult your local electrical agency.*

*You could be electrocuted or seriously injured if you operate or park the machine too close to power cables.*

*If the machine comes into contact with electrical cables, press the Emergency Stop button.*

*Call for help, warn people on the ground not to touch the machine, and ask them to switch off or get somebody to switch off the power supply to the cables.*

### **⚠ IMPORTANT ⚠**

*Do not use this machine during lightning storms, snow storms, during frosty periods or in hazardous weather conditions. In case of strong wind exceeding 45 km/h, do not make any movement that may endanger the machine's stability.*

- Comply with site safety regulations.
- The machine can be manoeuvred from the ground: ensure that you forbid access.
- If you have to use the machine in a dark area or at night, make sure it is equipped with working lights.
- The machines may not be used as cranes or elevators for the permanent transport of people or materials, nor as jacks or supports.
- Suspending a load under the platform or on any part of the lifting apparatus is strictly forbidden.
- When operating, ensure that there is no one or anything impeding the machine's progress and operation.
- When raising the platform, ensure that nothing/nobody is impeding the machine's operation and do not perform any inappropriate manoeuvres.
- Do not allow anybody to come near the working area of the machine or pass beneath the lifting structure or beneath the platform. To ensure this, mark out your working area.
- Driving on a slope:
  - Adjust the machine speed with the proportional control handle.
  - Make sure that the slope is not steeper than the maximum slope for the machine (<math>\leq 2</math> - DESCRIPTION).
- Take into account the machine's dimensions and its load before trying to negotiate a narrow or low passageway.
- Never move onto loading ramps without having first checked:
  - That they are suitably positioned and made fast.
  - That the vehicle to which it is connected (trailer, wagon, etc.) cannot move.
  - That they are suitable for the size and weight of the machine (<math>\leq 2</math> - DESCRIPTION).
  - That the slope is not steeper than the maximum slope for the machine (<math>\leq 2</math> - DESCRIPTION).
- Never move onto a foot bridge, floor or freight lift without being certain that they are suitable for the size and weight of the machine and without having checked that they are in sound working order.
- Be careful in the area of loading bays, trenches, scaffolding, soft ground, manholes, etc.
- Make sure the ground is stable and firm under the wheels and/or stabilisers before lifting the platform. If necessary, add sufficient wedging under the stabilisers.
- Do not attempt any operations outside the machine's capabilities.
- Ensure that any equipment and materials loaded onto the platform (pipes, cables, containers, etc.) cannot fall out. Do not pile this equipment and these materials to the point where it is necessary to step over them.

- Keep all body parts, conductive objects or parts of the machine a safe distance from power lines or live components, unless the local, government and national regulations in force, the employer's safety rules or the rules for work sites are stricter in terms of the distance required.
- Take into account the movement of the platform and the swinging or sagging of the power lines.
- To visually recognise the wind speed, refer to the empirical wind evaluation scale:

BEAUFORT scale (wind speed at a height of 10 m on a flat site)						
Force	Type of wind	Speed (knots)	Speed (km/h)	Speed (m/s)	Effects on Land	Sea conditions
0	Calm	0 - 1	0 - 1	<0.3	Smoke rises vertically.	Sea is like a mirror.
1	Light air	1 - 3	1 - 5	0.3 - 1.5	Smoke indicates direction of wind.	Ripples with appearance of scale, no foam crests.
2	Light breeze	4 - 6	6 - 11	1.6 - 3.3	Wind felt on face, leaves rustle.	Short wavelets, but pronounced.
3	Gentle breeze	7 - 10	12 - 19	3.4 - 5.4	Leaves and small twigs in constant motion.	Very small waves, crests begin to break.
4	Moderate breeze	11 - 16	20 - 28	5.5 - 7.9	Wind raises dust and loose pieces of paper; small branches are moved.	Small waves, becoming longer, numerous whitecaps.
5	Fresh breeze	17 - 21	29 - 38	8 - 10.7	Small trees in leaf begin to sway.	Wavelets form on inland waters; moderate waves, taking longer form.
6	Strong breeze	22 - 27	39 - 49	10.8 - 13.8	Large branches in motion, whistling heard in overhead wires, umbrella use becomes difficult.	Larger waves forming, whitecaps everywhere, some spray.
7	Near gale	28 - 33	50 - 61	13.9 - 17.1	Whole trees in motion, inconvenience felt when walking against the wind.	Sea heaps up; white foam from breaking waves begins to be blown in streaks along the direction of the wind.
8	Gale	34 - 40	62 - 74	17.2 - 20.7	Wind breaks twigs off trees; impedes progress.	Moderately high waves of greater length; edges of crests begin to break into spindrift.
9	Strong gale	41 - 47	75 - 88	20.8 - 24.4	Wind damages roofs (chimneys, slates, etc.).	High waves, crests of waves begin to topple, streaks of foam; reduced visibility.
10	Storm	48 - 55	89 - 102	24.5 - 28.4	Seldom experienced inland; trees uprooted; considerable structural damage occurs.	Very high waves; white streaks of foam; reduced visibility.
11	Violent storm	56 - 63	103 - 117	28.5 - 32.6	Very rare, widespread damage.	Exceptionally high waves able to hide medium sized ships from view, reduced visibility.
12	Hurricane	64 +	118 +	32.7 +	Devastating damage.	Sea completely white; air filled with foam and spray, very reduced visibility.

NOTE: The following chapter 5.8 is reproduced from AS2550.10—2006 Standard

## **5.8 WORKING IN PROXIMITY TO AERIAL CONDUCTORS (OVERHEAD POWER LINES)**

### **5.8.1 General**

Clause 5.8 refers to hazards and risks presented by the operation of MEWPs in the vicinity of overhead electrical conductors.

NOTES:

- 1 Occupational Health and Safety authorities and electricity supply bodies in each State may have issued guidelines for the use of cranes and other plant in the vicinity of overhead conductors.
- 2 A conservative approach has been adopted. Separation distances have not been determined based purely on electrical voltages of conductors, nor whether the conductor is bare or insulated. The distances were chosen based on experience and practical considerations, since MEWPs cannot be operated as accurately as arcing distances can be calculated.

Before setting the MEWP into operational configuration, a check for the presence of overhead conductors and power lines shall be undertaken.

Throughout Clause 5.8, the following definitions apply:

- (a) *Aerial conductor*—an overhead conductor that is either insulated or bare.
- (b) *Operation*—where any MEWP components are moved or about to be moved from their transport configuration and in the instance of MEWPs having stabilizers, where stabilizers are moved or about to be moved from their transport configuration.
- (c) *Overhead power line*—aerial conductors and other parts that make up an aerial line for the distribution and transmission of electrical energy.
- (d) *Electricity distributor*—the power supply authority, transmission line operator, generator, traction company or distribution company.

All aerial conductors shall be treated as live unless documentary evidence that the conductors have been positively de-energized, isolated or earthed has been received from the electricity distributor or transmission line operator.

Where such documentary evidence has been made available, it shall state the date and time frame of isolation and any special conditions and precautions. The MEWP shall not be operated in contravention of this documentary information.

### **5.8.2 Precautions when operating near live aerial conductors**

The MEWP shall only be operated within close proximity of live aerial conductors, if the separation distances appropriate to the 'NO-GO-ZONE' or 'SPOTTER-REQUIREDZONE', and risk controls given in Clause 5.8.3, are maintained.

A site-specific risk assessment shall be completed before the commencement of the job by a trained and competent person. This assessment shall be verified immediately before work commences, and its relevance monitored during the job. If initial circumstances change, work shall cease until an appropriate risk assessment is undertaken.

Where a spotter is required to inform the operator in the event of the MEWP approaching the zone boundaries shown, the following applies:

- (a) The spotting operation shall be carried out by a competent person.  
NOTE: Required competency levels may be defined by the applicable State authority.
- (b) The spotter shall be positioned so that the exposure to hazards is eliminated or minimized.
- (c) The spotter shall be able to clearly observe the separation distances.
- (d) The spotter shall not undertake any other work whilst performing spotting duties.
- (e) The spotter shall be specifically instructed in the workplace hazards applicable to the site.
- (f) The spotter shall be able to communicate with the MEWP operator at all times during erection, operation and dismantling.

### 5.8.3 Separation distances and risk controls

Where possible, the zone separation distances should be not less than those shown in Figure 5.8.3.

NOTE: The separation distances shown in Figure 5.8.3 include allowance for sag and sway of line(s) due to the effects of wind and temperature.

Where the separation distances cannot be achieved, the electricity distributor shall be notified in writing. The MEWP shall not be operated within the 'no go zone' until the applicable requirements below are satisfied.

When operating in the vicinity of aerial conductors, the separation distance between the MEWP and aerial conductor and risk controls shall comply with the following:

- (a) *Overhead power lines (up to and including 133 kV)* The following applies:
- (i) *Spotter required zone* The MEWP shall not be operated in the 'spotter required zone' as indicated in Figure 5.8.3 for overhead power lines up to and including 133 kV, unless—
- (A) the electricity distributor is notified before commencing work;
  - (B) written permission from the electricity distributor has been obtained;
  - (C) the MEWP is insulated in accordance with the requirements of AS 1418.10(Int.);
  - (D) a spotter performs spotting duties;
  - (E) a pre-start site/job meeting has been convened and a risk assessment completed; and
  - (F) the MEWP is equipped with one controlled descent device located at the platform or basket for each occupant, and each occupant is trained and experienced in its use.
- NOTE: The controlled descent device is not an emergency retrieval device.
- (ii) *No go zone* The MEWP shall not be operated in the 'no go zone' as indicated in Figure 5.8.3 for overhead power lines up to and including 133 kV, unless—
- (A) the electricity distributor is notified before commencing work;
  - (B) written permission from the electricity distributor has been obtained;
  - (C) all conditions specified by the electricity distributor are complied with;
  - (D) the MEWP is insulated in accordance with the requirements of AS 1418.10(Int.);
  - (E) a spotter performs spotting duties;
  - (F) a pre-start site/job meeting has been convened and a risk assessment completed; and
  - (G) the MEWP is equipped with one controlled descent device located at the platform or basket for each occupant, and each occupant is trained and experienced in its use.
- NOTE: The controlled descent device is not an emergency retrieval device.
- (b) *Overhead power lines (greater than 133 kV)* The following applies:
- (i) *Spotter required zone* The MEWP shall not be operated in the 'spotter required zone' as indicated in Figure 5.8.3 for overhead power lines greater than 133 kV, unless—
- (A) written permission from the electricity distributor has been obtained;
  - (B) an easement entry permit has been provided by the electricity distributor;
  - (C) a spotter performs spotting duties;
  - (D) a pre-start site/job meeting has been convened and a risk assessment completed;
  - (E) the MEWP is insulated in accordance with the requirements of IEC61057 or ANSI/SIA A92.2; and
  - (F) the MEWP is equipped with one controlled descent device located at the platform or basket for each occupant, and each occupant is trained and experienced in its use.
- NOTE: The controlled descent device is not an emergency retrieval device.

- (ii) *No go zone* The MEWP shall not be operated in the 'no go zone' as indicated in Figure 5.8.3 for overhead power lines greater than 133 kV, unless—
- (A) an easement entry permit has been provided by the electricity distributor;
  - (B) written permission from the electricity distributor has been obtained;
  - (C) all conditions specified by the electricity distributor are complied with;
  - (D) the electricity distributor is notified before commencing work;
  - (E) a spotter performs spotting duties;
  - (F) a pre-start site/job meeting has been convened and a risk assessment completed;
  - (G) the MEWP is insulated in accordance with the requirements of IEC61057 or ANSI/SIA A92.2; and
  - (H) the MEWP is equipped with one controlled descent device located at the platform or basket for each occupant, and each occupant is trained and experienced in its use.
- NOTE: The controlled descent device is not an emergency retrieval device.
- (iii) *Spotter required zone* The MEWP shall not be operated in the 'spotter required zone' as indicated in Figure 5.8.3 for overhead power lines greater than 133 kV, unless—
- (A) written permission from the electricity distributor has been obtained;
  - (B) an easement entry permit has been provided by the electricity distributor;
  - (C) a spotter performs spotting duties;
  - (D) a pre-start site/job meeting has been convened and a risk assessment completed;
  - (E) the MEWP is insulated in accordance with the requirements of IEC61057 or ANSI/SIA A92.2; and
  - (F) the MEWP is equipped with one controlled descent device located at the platform or basket for each occupant, and each occupant is trained and experienced in its use.
- NOTE: The controlled descent device is not an emergency retrieval device.
- (c) *Public transport authorities* Where aerial conductors are dedicated to the use of public transport authorities (e.g. tramways and railways), the separation distance shall be the same as that for aerial conductors up to and including 133 kV (see Item (a))
- (d) *Downshop conductors* Before mobile machinery is set up for operation in the vicinity of downshop conductors, the power supply to the conductors shall be isolated unless appropriate control measures have been developed and implemented.
- NOTES:
- 1 Downshop conductors (e.g. collector rails), should be clearly identified.
  - 2 Clearances from downshop conductors should be in accordance with AS/NZS 3000.
- (e) *Barriers at ground level* Where people not involved in the operation could otherwise come into the area of possible voltage step potential, barriers shall be provided at ground level to prevent this from occurring. Appropriate warning signs shall be displayed on the barriers. Pedestrians should be barricaded from the area of possible voltage step potential (see Figure 5.8.4) in the vicinity of the MEWP and associated equipment.
- (f) *Earthing systems* An appropriate earthing system shall be fitted to the MEWP and shall be in use. Operators and those working in proximity to the MEWP shall be advised of the limits of the effectiveness of the earthing equipment.
- (g) *High visibility bunting* Where high visibility bunting, for example 'tiger tails' is applied to the conductors, it shall be regarded as a visual indicator only and not as insulation.

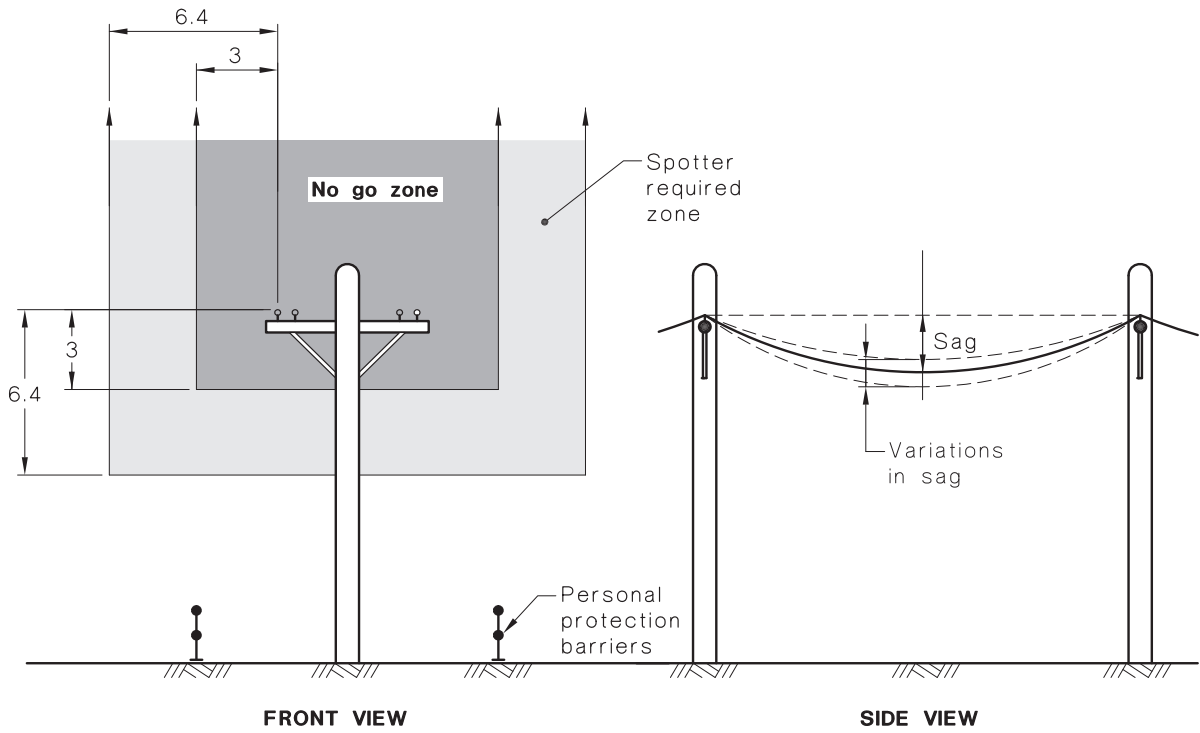

FRONT VIEW SIDE VIEW

(a) Distribution lines up to and including 133 kV

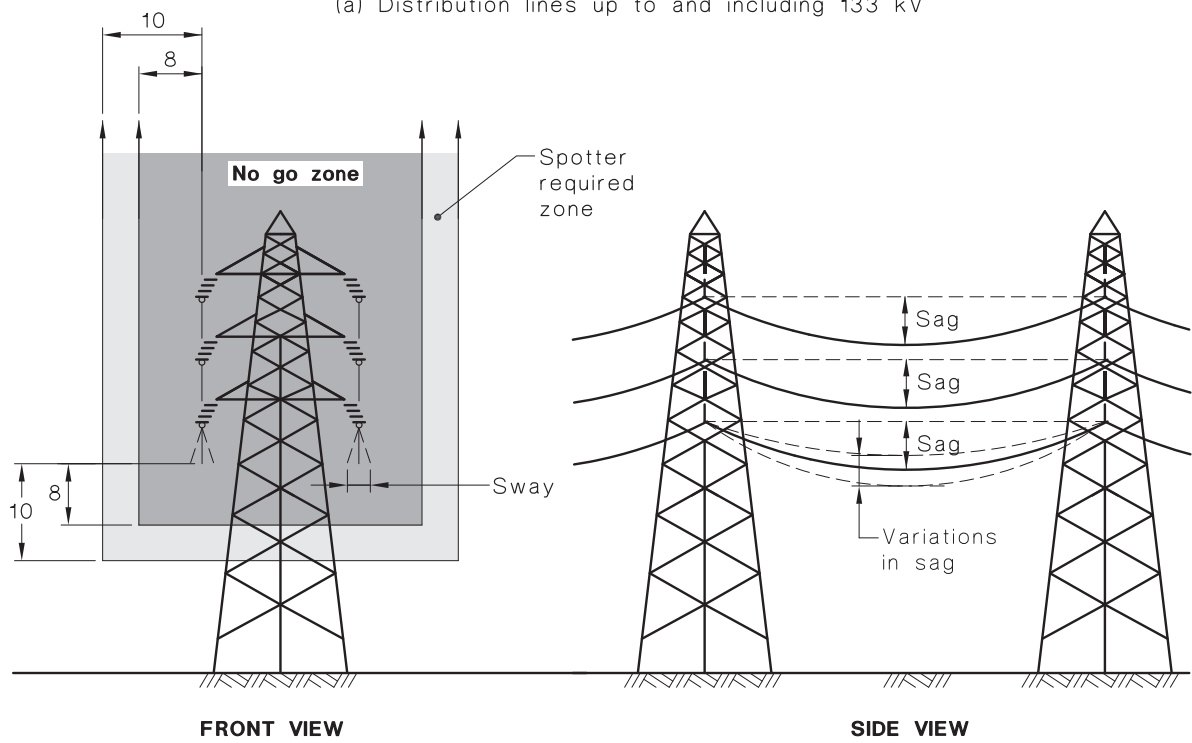

FRONT VIEW SIDE VIEW

(b) Transmission lines greater than 133 kV

LEGEND:

- = No shading, in the front views, indicates no proximity requirements
- = Light shading indicated spotter is required
- = Heavy shading indicates the NO GO ZONE

DIMENSIONS IN METRES

FIGURE 5.8.3 CLEARANCES FROM LIVE AERIAL CONDUCTORS

#### 5.8.4 Aerial conductors contact

If the MEWP or load contacts aerial conductors, the relevant electricity distributor shall be immediately notified of the situation and, until assistance is received, a competent person shall remain in a prominent position to warn of the danger of electrocution.

In such an event the MEWP operator should act as follows:

- (a) Remain on the MEWP.
- (b) Warn all other personnel to keep away from the MEWP and not touch any part of the MEWP.
- (c) Without anyone approaching the MEWP, operate the MEWP in such a manner to break contact, where possible.
- (d) When unable to move or disentangle the MEWP from the aerial conductors, remain on the MEWP and take no further action until it is confirmed that conditions are safe.
- (e) Only when it is essential to leave the MEWP because of fire or some other reason, to avoid being electrocuted, the following actions should be taken:
  - (i) For personnel on the chassis of the vehicle, jump clear as far away from the MEWP as possible and avoid touching the MEWP and the ground at the same time. When moving away from the MEWP, shuffle or hop slowly across the affected area to avoid a simultaneous contact across areas of high potential difference (see Figure 5.8.4)
  - (ii) For personnel in the platform or basket, escape using a controlled descent device. When moving away from the MEWP, shuffle or hop slowly across the affected area to avoid a simultaneous contact across areas of high potential difference (see Figure 5.8.4).

Where the MEWP operator is immobilized, the power shall be isolated before assistance is given.

When a MEWP has been in contact with a live aerial conductor, it shall be withdrawn from service and checked by a competent person for any damage to its components. Any actions recommended by the competent person shall be completed before the MEWP is returned to service.

NOTE: AS 1418.10(Int) provides additional guidelines relating to inspection of MEWPs following contact with powerlines.

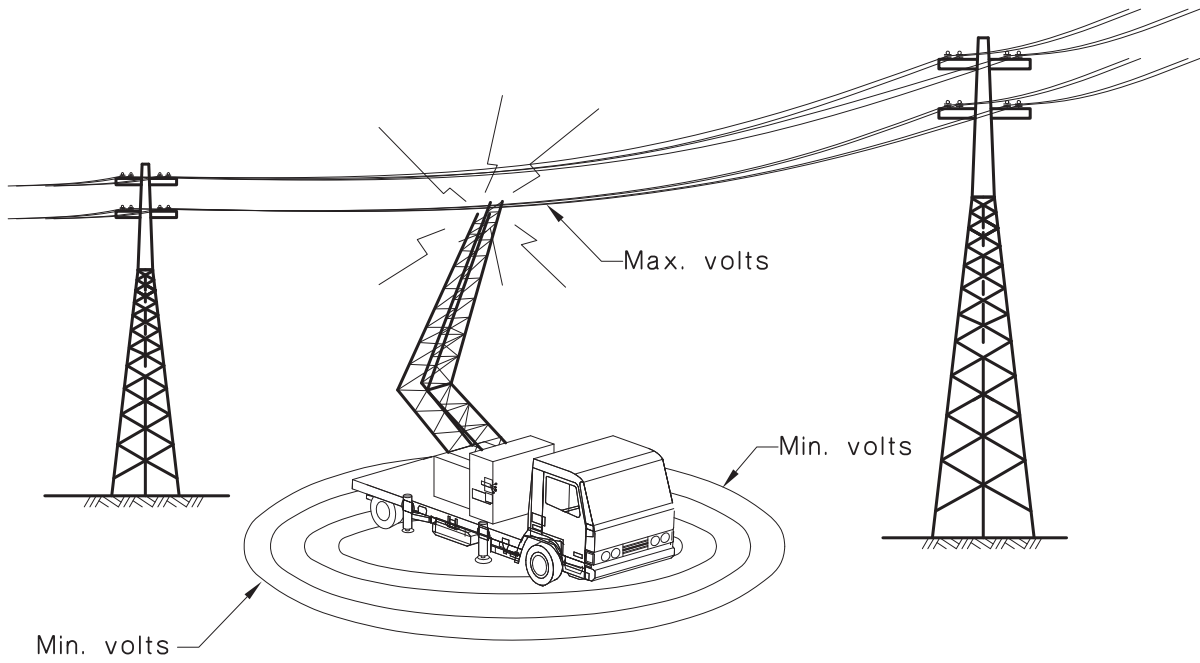

(a) Affected area

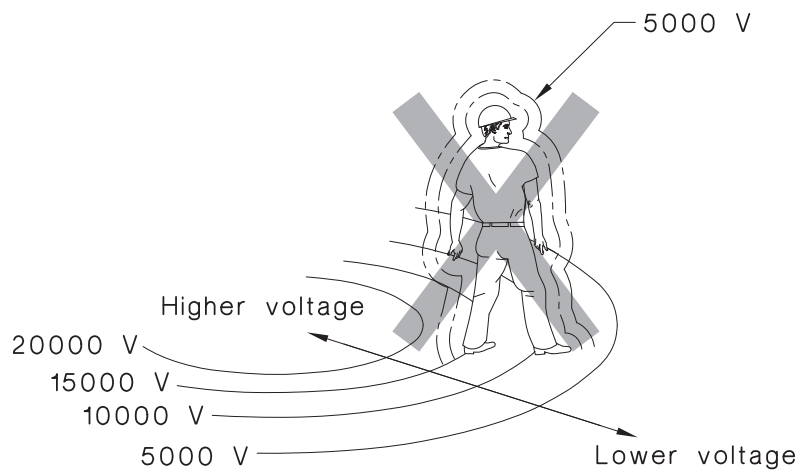

(b) Avoid simultaneous contact across areas of high potential difference

FIGURE 5.8.4 TYPICAL AFFECTED AREA SURROUNDING A MEWP WHEN IN CONTACT WITH A LIVE AERIAL CONDUCTOR

## D - VISIBILITY

- Ensure good visibility of your route at all times. To increase your visibility, you can move forwards with the jib slightly raised (beware of the risk of falls in the platform from knocking into a low doorway, overhead electric wires, travelling cranes, road bridges, railway lines or any obstacle in the area in front of the machine). While reversing, look directly behind you. In any case, avoid reversing long distances.
- If visibility of your road is inadequate, ask someone to help, standing outside the area in which the machine will be moving, and make sure you always have a good view of this person.

## E - STARTING MACHINES WITH A DIESEL ENGINE

### **⚠ IMPORTANT ⚠**

*Failure to respect polarity between batteries can cause serious damage to the electrical circuit.*

*The electrolyte in the battery may produce an explosive gas.*

*Avoid flames and generation of sparks close to the batteries. Never disconnect a battery while it is being charged.*

- INSTRUCTIONS: <img alt="arrow icon" data-bbox="218 241 233 256"/> 2 - DESCRIPTION.
- If using an emergency battery for start-up, use a battery with the same characteristics and respect battery polarity when connecting it. Connect the positive terminal first, and then the negative terminal.

## F - SWITCHING ON ELECTRICAL MACHINES

- INSTRUCTIONS: <img alt="arrow icon" data-bbox="218 314 233 329"/> 2 - DESCRIPTION
- Do not use the machine if the battery or batteries are discharged to the point that movements are slowed down. In certain cases, the machine may stop (<img alt="arrow icon" data-bbox="218 349 233 364"/> 2 - DESCRIPTION for the charge level not to be exceeded).

## G - DRIVING THE MACHINE

### **⚠ IMPORTANT ⚠**

*Operators should be aware of the risks connected with using this machine, notably:*

*- Risk of losing control.*

*- Risk of the machine becoming unstable.*

*The operator must remain in control of the machine at all times.*

- Do not attempt any operations outside the machine's capabilities.
- Familiarise yourself with the machine on the terrain where it will be used.
- Driving long distances should always be done with the machine in the transport position (<img alt="arrow icon" data-bbox="725 504 740 519"/> 2 - DESCRIPTION).
- Drive smoothly and adapt the machine's speed to the usage conditions (ground configuration, load in the platform, etc.). Depending on the machine model, select the appropriate speed for the usage conditions (<img alt="arrow icon" data-bbox="725 539 740 554"/> 2 - DESCRIPTION).
- Keep control of the speed in all circumstances.
- Ensure that the brakes work efficiently, taking into account the braking distances.
- Take extreme care when manoeuvring the machine with the platform raised. Ensure that there is sufficient visibility.
- Take bends slowly.
- Look where you are going and always make sure you have good visibility along the route.
- Drive round obstacles.
- Never drive on the edge of a ditch or steep slope.
- Travel slowly on damp, slippery or uneven terrain or on loading ramps.
- Machines with a diesel engine: never leave the engine running when the machine is unattended.
- Never leave the machine switched on during the operator's absence.
- Whatever your operating speed, you must reduce the speed as much as possible before stopping.
- The machine should be operated in an area free of any obstructions or danger when the platform is lowered to the ground.
- Pay attention to structures, objects and people when manoeuvring.
- The operator using the machine must be aided on the ground by a person with adequate training.
- Remain within the limits of the machine's movement amplitude (<img alt="arrow icon" data-bbox="554 829 569 844"/> 2 - DESCRIPTION).
- Do not load the platform if the machine needs to travel on a steep slope.

## H - SHUTTING DOWN THE MACHINE

### **⚠ IMPORTANT ⚠**

*Machines with a diesel engine: before stopping the engine after intensive use, leave the engine idling for a few moments to allow the coolant and oil to gradually lower the temperature of the engine and prevent damage.*

- INSTRUCTIONS: <img alt="arrow icon" data-bbox="218 111 235 125"/> 2 - DESCRIPTION.
- Park the machine on a flat surface.
- Make sure that the machine is not stopped in any position that will interfere with the traffic flow and in particular the machine should not be less than one metre from a railway track.
- Never leave the ignition key in the machine during the operator's absence.
- Close and lock (if applicable) all the machine's covers.
- In the event of prolonged parking on a site, protect the machine from bad weather, particularly from frost. Machines with a diesel engine: check the antifreeze protection level.

## **INSTRUCTIONS FOR WELDING AND BLOW TORCH WORK ON AN EXTERNAL STRUCTURE**

---

### **⚠ IMPORTANT ⚠**

*Ensure that there are no hydraulic or electrolyte leaks on the machine.*

### **⚠ IMPORTANT ⚠**

*When welding, work in the opposite direction from the control panel to avoid sparks damaging it.*

- Any welding and cutting (blowtorch) work from the platform on a building's metallic structures requires the following precautions to be taken:

#### **A - WITH AN ELECTRICAL WELDING SET**

- It is essential that the machine has a discharge braid connecting the chassis of the machine to the ground.
- It is also essential that the external structure to be welded is connected to the earth.
- If the above conditions are observed, the machine can, in this case, be in contact with the structure or the elements to be welded without damaging the electronic components.
- The power supply to the welding equipment must be via a grounded socket, including the extension lead if required.
- In all cases, make sure that there are no electric arcs in the platform or on the machine (contact between the rod or torch and ground plug of the welding equipment). For this, the ground plug of the welding equipment must never be placed on the machine's platform; it must only be placed as close as possible to the part to be welded.
- Switch off the welding equipment before disconnecting the ground clamp from the element or elements to be welded.

#### **B - WITH A BLOW TORCH**

- Attach the blow torch's bottles to the platform's vertical posts.
- Sparks and clippings must not be directed towards the battery or batteries.
- Do not set the blow torch down on the floor of the platform while it is still operating or point it towards the control panel or its power supply harness.

# MACHINE MAINTENANCE INSTRUCTIONS

## GENERAL INSTRUCTIONS

### **⚠ IMPORTANT ⚠**

*Carefully read and understand this instruction manual before working on this machine.*

*Carry out all repairs immediately, even if the repairs concerned are minor.*

*Repair all leaks immediately, even if the leak concerned is minor.*

*Be careful of the risk of burning and splashing (exhaust, radiator, engine, hydraulic oil, etc.).*

- Wear clothes suitable for the maintenance of the machine, avoid wearing jewellery and loose clothes. Tie and protect your hair, if necessary.
- Ensure that process materials and of spare parts are disposed in all safely and in an ecological manner.
- Machines with a diesel engine:
  - Make sure the area is adequately ventilated before starting the engine.
  - Before working on the machine: turn off the engine and power down the machine (↖ 2 - DESCRIPTION).
- Electrical machines:
  - Before working on the machine: power down the machine (↖ 2 - DESCRIPTION).

## MAINTENANCE

- Perform the periodic service (↖ 3 - MAINTENANCE) to keep your machine in good working condition. Failure to perform the periodic service may annul the contractual guarantee.

### MAINTENANCE LOGBOOK

- The maintenance operations carried out in accordance with the recommendations given in section 3 - MAINTENANCE and the other inspection, servicing or repair operations or modifications performed on the machine must be recorded in a maintenance logbook.
- The entry for each operation shall include details of the date of the works, the names of the individuals or companies having performed them, the type of operation and its frequency, if applicable.
- The part numbers of any machine items replaced shall also be indicated.

## LUBRICANT AND FUEL LEVELS

- Use the recommended lubricants and never use contaminated lubricants.
- Machines with a diesel engine:
  - Do not fill the fuel tank when the engine is running.
  - Only fill up the fuel tank in areas specified for this purpose.
  - Do not smoke or approach the machine with a flame, when the fuel tank is open or is being filled.

## HYDRAULICS

### **⚠ IMPORTANT ⚠**

*COUNTERBALANCE VALVE: it is dangerous to change the setting or remove the counterbalance valves or safety valves which may be fitted to your machine's cylinders.*

*These operations must only be performed by approved personnel (consult your dealer).*

*HYDRAULIC ACCUMULATOR (depending on the model): it is dangerous to disassemble the hydraulic accumulators and their pipes that may be on your machine. These operations must only be performed by approved personnel (consult your dealer).*

- Any work on the hydraulic circuit is forbidden except for the operations described in section 3 - MAINTENANCE.
- Do not attempt to loosen unions, hoses or hydraulic components with the circuit under pressure.

## ELECTRICITY

---

### **⚠ IMPORTANT ⚠**

*Certain maintenance operations may need electrical accreditation: comply with local, government and national regulations in force.  
After each job, make sure that electrical component protection is put back in place (caps, covers, terminal covers, etc.).*

- Do not drop metallic items on the battery or batteries (between the positive and negative terminals).
- Disconnect the battery or batteries before working on the electrical circuit.
- The control panels on the ground and in the platform and all other electrical control boxes must only be opened by authorised personnel.

## TILT SENSOR

---

### **⚠ IMPORTANT ⚠**

*Some machines are fitted with a tilt sensor attached to the turntable (⚠ 2 - DESCRIPTION: CONTROL PANEL AND SAFETY DEVICES ON THE GROUND), always carry out an initialisation after removing/refitting the tilt sensor. Refer to the machine repair manual.*

*Some platforms are fitted with a tilt sensor that is integrated into the ground level control panel (⚠ 2 - DESCRIPTION: CONTROL PANEL AND SAFETY DEVICES ON THE GROUND), always calibrate the tilt sensor after removing/refitting or loosening/tightening the ground level control panel, its mounting plates or fixing screws. Refer to the machine repair manual.*

## WELDING ON THE MACHINE

---

### **⚠ IMPORTANT ⚠**

*Welding operations on the machine for the purposes of maintenance or repairs must only be carried out by persons authorised by MANITOU.*

- Disconnect the battery or batteries before doing any welding on the machine.
- When carrying out electric welding work on the machine, connect the negative cable from the welding equipment directly to the part being welded, so as to avoid high tension current passing through the alternator or the ring gear.
- If the machine is equipped with electronic controls, disconnect them before starting to weld, to avoid the risk of causing irreparable damage to electronic components.

## WASHING THE MACHINE

---

### **⚠ IMPORTANT ⚠**

*When cleaning with a high pressure cleaner, avoid air from entering the engine, the piston rod wiper seals, the hinges, the structural components and the electrical connections, etc.*

- Clean the machine or at least the area concerned before any intervention.
- Close and lock (if applicable) all the machine's covers.
- If necessary, protect components likely to be damaged, and in particular the electrical components (variable speed drive, charger) and electrical connections and the injection pump from penetration by water, steam or cleaning products.
- Clean the machine of any traces of fuel, oil or grease.
- After washing:
  - Dry the electrical components.
  - Grease the axles, pins, ring gear, etc.

## IF THE MACHINE IS NOT TO BE USED FOR A LONG TIME

### INTRODUCTION

---

#### **⚠ IMPORTANT ⚠**

*Procedures to follow if the machine is not to be used for a long time and for starting it up again afterwards must be performed by your dealership.  
This period of long-term stoppage must not exceed 12 months.*

- The recommendations below are intended to prevent the machine from being damaged when it is withdrawn from service for a period longer than 6 months.

### PREPARATION OF THE MACHINE

---

- Clean the machine thoroughly.
- Check and repair any leaks of fuel, oil, etc.
- Replace or repair any worn or damaged parts.
- Touch up the paintwork if necessary.
- Make sure the cylinder rods are in the retracted position (if applicable).
- Shut down the machine.
- Release the pressure in the hydraulic circuits.

### MACHINES WITH A DIESEL ENGINE: ENGINE PROTECTION

---

- Fill the fuel tank (↩ 3 - MAINTENANCE).
- Replace the engine oil and oil filter (↩ 3 - MAINTENANCE).
- Replace the coolant (↩ 3 - MAINTENANCE).
- Disconnect the battery and store it in a safe place away from the cold, after charging it to a maximum.
- Block the outlet with waterproof adhesive tape.
- Remove the belt and store it in a safe place.
- Disconnect the engine cut-off solenoid on the injection pump and carefully insulate the connection.

### ELECTRICAL MACHINES: BATTERY CHARGE

---

- In order to preserve battery life and capacity, check them periodically and keep the charge level constant (↩ 2 - DESCRIPTION).
- Do not leave the battery charger connected during a lightning storm.

### PROTECTING THE MACHINE

---

- Protect cylinder rods that will not be retracted from corrosion.
- Wrap the wheels.

NOTE: if the machine is to be stored outdoors, cover it with a waterproof tarpaulin.

**⚠ IMPORTANT ⚠**

*Make sure the area is adequately ventilated before starting machines with a diesel engine.*

- Remove the protection from the cylinder rods and wheels.
- Check the hydraulic oil (↖ 3 - MAINTENANCE).
- Machines with a diesel engine:
  - Refit and reconnect the battery.
  - Remove the waterproof adhesive tape from the exhaust outlet.
  - Clean the fuel tank (replace the fuel), replace the fuel filter(s) (↖ 3 - MAINTENANCE).
  - Refit the belt and adjust its tension (↖ 3 - MAINTENANCE).
  - Reconnect the engine cut-off solenoid.
  - Start the engine, following the safety instructions and regulations.
- Perform the daily maintenance (↖ 3 - MAINTENANCE).
- Lubricate the machine completely (↖ 3 - MAINTENANCE).
- Carry out all the lifting system's hydraulic movements right up to the limit switches for each cylinder.

## DISPOSING OF THE MACHINE



*Consult your dealer before disposing of the machine.*

### RECYCLING OF MATERIALS

---

#### METALS

- Metals are 100% recoverable and recyclable.

#### PLASTICS

- Plastic parts are identified with a marking in accordance with current regulations.
- A limited range of materials is used to simplify the recycling process.
- The majority of the plastic components are made of "thermoplastic" plastics, which are easily recycled by melting, granulating or grinding.

#### RUBBER

- Tyres and seals can be ground for use in cement manufacture or to obtain reusable granules.

#### GLASS

- Glass items can be removed and collected for processing by glaziers.

### ENVIRONMENTAL PROTECTION

---

By entrusting the maintenance of your machine to the MANITOU network, the risk of pollution is limited and the contribution to environmental protection is made.

#### WORN OR DAMAGED PARTS

- Do not dump them in the countryside.
- MANITOU and its network have signed-up to a scheme of environmental protection through recycling.

#### USED OIL

- The MANITOU network organises the collection and processing of used oil.
- By handing over your waste oil to MANITOU, the risk of pollution is limited.

#### USED BATTERIES

- Do not throw away batteries, as they contain metals that are harmful for the environment.
- Return them to the MANITOU network or any other approved collection point.

NOTE: MANITOU aims to manufacture machines that provide the best performance and limit polluting emissions.

# ***2 - DESCRIPTION***

## 2 - DESCRIPTION

<b>COMPONENT LOCATIONS</b>	<b>2-4</b>
<b>STICKERS</b>	<b>2-6</b>
<b>SPECIFICATIONS</b> 160 ATJ	<b>2-19</b>
<b>DIMENSIONS AND AMPLITUDE OF MOVEMENT</b> 160 ATJ	<b>2-24</b>
<b>SPECIFICATIONS</b> 180 ATJ	<b>2-27</b>
<b>DIMENSIONS AND AMPLITUDE OF MOVEMENT</b> 180 ATJ	<b>2-30</b>
<b>SAFETY COMPONENTS</b>	<b>2-32</b>
<b>SLIDING MID RAIL</b> . . . . .	<b>2-32</b>
<b>SLIDING MID RAIL AND GATE</b> . . . . .	<b>2-32</b>
<b>SAFETY HARNESS ATTACHMENT POINTS</b> . . . . .	<b>2-32</b>
<b>HANDRAILS</b> . . . . .	<b>2-32</b>
<b>TURNTABLE LOCKING PIN</b> . . . . .	<b>2-33</b>
<b>CONTROL PANEL AND SAFETY DEVICES AT GROUND LEVEL</b>	<b>2-34</b>
<b>CONTROL PANEL AND SAFETY DEVICES IN THE PLATFORM</b>	<b>2-36</b>
<b>GROUND LEVEL DISPLAY SCREEN</b>	<b>2-53</b>
<b>POWER-UP CYCLE</b> . . . . .	<b>2-53</b>
<b>DISPLAY ZONES</b> . . . . .	<b>2-53</b>
<b>PREHEAT PAGE</b> . . . . .	<b>2-55</b>
<b>WORK PAGE</b> . . . . .	<b>2-55</b>
<b>ALERT PAGE AND FAULT PAGE</b> . . . . .	<b>2-56</b>
<b>OPERATING THE MACHINE</b>	<b>2-58</b>
<b>TRANSPORT/WORKING POSITION</b> . . . . .	<b>2-58</b>
TRANSPORT POSITION . . . . .	2-58
WORKING POSITION . . . . .	2-58
<b>OPERATION FROM THE GROUND LEVEL CONTROL PANEL</b> . . . . .	<b>2-59</b>
SWITCH ON THE MACHINE . . . . .	2-59
SWITCH OFF THE MACHINE . . . . .	2-59
START THE DIESEL ENGINE . . . . .	2-59
SWITCH OFF THE DIESEL ENGINE . . . . .	2-59
POSITION THE PLATFORM . . . . .	2-59
ACTIVATE SIMULTANEOUS FUNCTIONS . . . . .	2-59
EMERGENCY STOP . . . . .	2-59
<b>USE FROM THE PLATFORM CONTROL PANEL</b> . . . . .	<b>2-60</b>
TURN THE MACHINE ON/OFF . . . . .	2-60
START THE DIESEL ENGINE . . . . .	2-60
SWITCH OFF THE DIESEL ENGINE . . . . .	2-60
DRIVE, STEER AND BRAKE THE MACHINE . . . . .	2-60
POSITION THE PLATFORM . . . . .	2-60
ACTIVATE SIMULTANEOUS FUNCTIONS . . . . .	2-60
EMERGENCY STOP . . . . .	2-60

**DIESEL ENGINE AUTOMATIC STOP SYSTEM "STOP AND GO" . . . . . 2-61**

**LOCKED FUNCTIONS . . . . . 2-62**

    MACHINE IN TRANSPORT POSITION . . . . . 2-62

    MACHINE IN WORKING POSITION . . . . . 2-63

**EMERGENCY CONTROLS . . . . . 2-64**

**SHOULD THE USER FEEL ILL - PRIORITY CONTROLS FROM THE GROUND . . . . . 2-64**

**IF THERE IS A BREAKDOWN - EMERGENCY CONTROLS FROM THE PLATFORM . . . . . 2-64**

**IF THERE IS A BREAKDOWN - EMERGENCY CONTROLS FROM THE GROUND . . . . . 2-65**

**STANDARD EQUIPMENT . . . . . 2-69**

**OSCILLATING FRONT AXLE . . . . . 2-69**

**OPTIONS . . . . . 2-70**

**KEY LOCK FOR TURNTABLE COVERS . . . . . 2-70**

**BATTERY CUT-OFF . . . . . 2-70**

**230 V ELECTRIC POWER SOCKET IN THE PLATFORM . . . . . 2-70**

**BATTERY HEATER . . . . . 2-71**

**HYDRAULIC OIL HEATER . . . . . 2-71**

**ENGINE BLOCK HEATER . . . . . 2-72**

**ELECTRIC GENERATOR . . . . . 2-73**

**PLATFORM WORKLIGHT . . . . . 2-74**

**TURNTABLE SLEWING ALARM . . . . . 2-75**

**SECONDARY PROTECTION SYSTEM SPS . . . . . 2-76**

**TRANSPORT AND LIFTING . . . . . 2-78**

**TRANSPORT INSTRUCTIONS . . . . . 2-78**

    LOADING/UNLOADING THE MACHINE . . . . . 2-78

    CONFIGURE THE MACHINE FOR TRANSPORT . . . . . 2-79

    SECURING THE MACHINE 160 ATJ . . . . . 2-80

    SECURING THE MACHINE 180 ATJ . . . . . 2-81

**FREEWHEEL FOR WINCHING . . . . . 2-82**

**LIFTING INSTRUCTIONS 160 ATJ . . . . . 2-84**

**LIFTING INSTRUCTIONS 180 ATJ . . . . . 2-86**

## COMPONENT LOCATIONS

Note: the illustrations show a 160 ATJ.

Note: front, rear, left and right are defined in OPERATING THE MACHINE: TRANSPORT/WORKING POSITION.

- 1- STANDARD PLATFORM
- 2- WIDE PLATFORM WITHOUT GATE (OPTION)
- 3- WIDE PLATFORM WITH GATE (OPTION)
- 4- STORAGE BOX
- 5- SLIDING MID RAIL
- 6- PLATFORM CONTROL PANEL
- 7- FOOT SWITCH
- 8- GATE
- 9- JIB ARM
- 10- TELESCOPIC ARM
- 11- MAIN ARM
- 12- SECONDARY ARM
- 13- TURNTABLE
- 14- TURNTABLE LOCKING PIN
- 15- LIFT LOCK
- 16- RIGHT-HAND TURNTABLE COVER
- 17- GROUND LEVEL CONTROL PANEL
- 18- HORN
- 19- ORANGE ROTATING BEACON LIGHT
- 20- LEFT-HAND TURNTABLE COVER
- 21- FRAME
- 22- REAR AXLE
- 23- DRIVING AND STEERING REAR WHEELS
- 24- OSCILLATING FRONT AXLE
- 25- DRIVING AND STEERING FRONT WHEELS
- 26- REAR CHASSIS COVER
- 27- FRONT CHASSIS COVER
- 28- RIGHT-HAND CHASSIS COVER
- 29- LEFT-HAND CHASSIS COVER

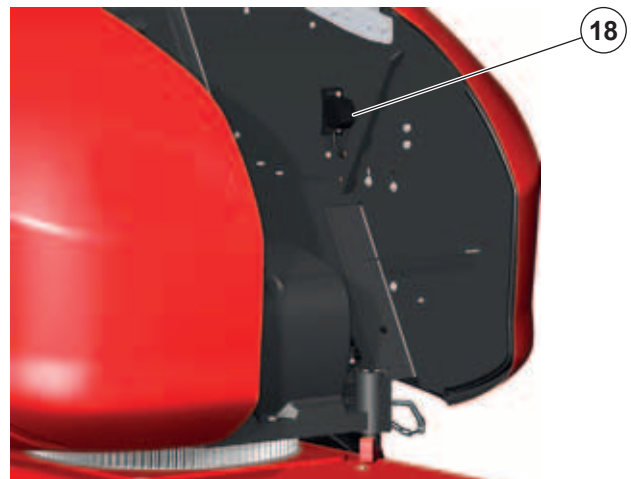
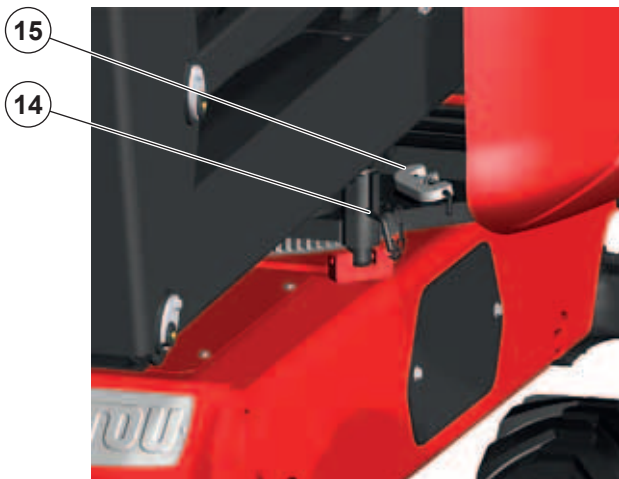

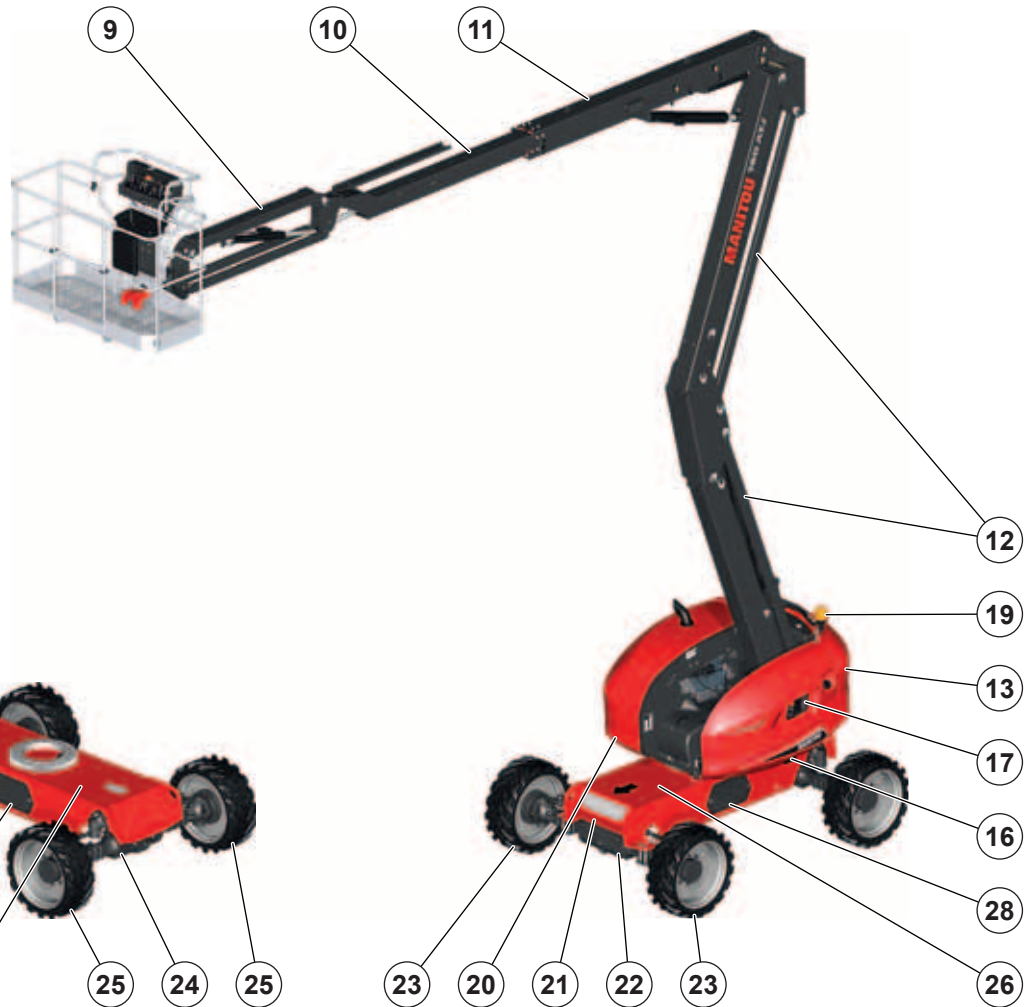
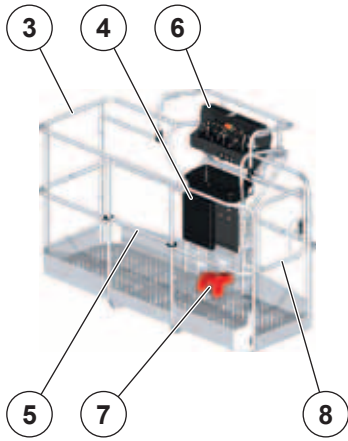
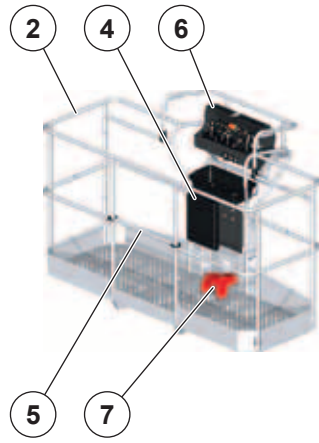
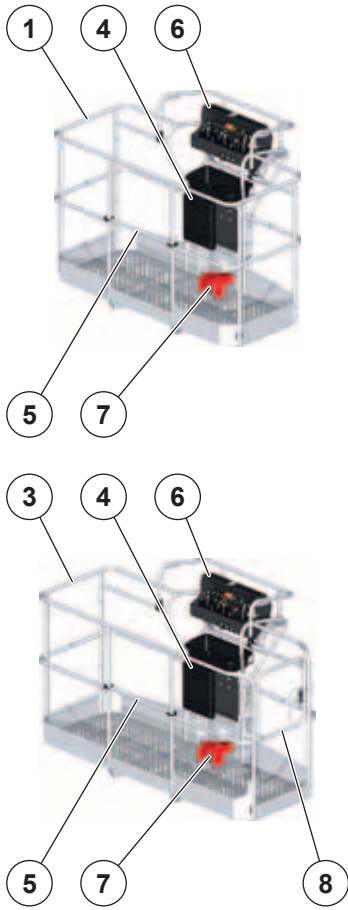

647909 (A112020)  
 160 ATJ 4RD ST5 S2 / 160 ATJ RC 4RD ST5 S2  
 180 ATJ 4RD ST5 S2 / 180 ATJ RC 4RD ST5 S2

## STICKERS

### **⚠ IMPORTANT ⚠**

*Clean all the stickers so that they are legible.  
Any stickers which are illegible or damaged must be replaced.  
Check that the stickers are present after replacing any spare parts.*

Note: the illustrations show a 160 ATJ with a standard platform.

1- WHITE ARROW (STANDARD) .....	Part No. 833553 .....	2-10
2- WHITE ARROW WITH BLACK OUTLINE (OPTION) .....	Part No. 52588045 .....	2-10
3- BLACK ARROW .....	Part No. 833554 .....	2-10
4- PLATFORM SAFETY INSTRUCTIONS .....	Part No. 676814 .....	2-10
5- ELECTRICAL SAFETY DISTANCES .....	Part No. 834436 .....	2-11
6- GROUND SAFETY INSTRUCTIONS .....	Part No. 52621077 .....	2-11
7- WHEEL LOAD 160 ATJ .....	Part No. 683963 .....	2-11
8- WHEEL LOAD 180 ATJ .....	Part No. 313819 .....	2-11
9- USE MANITOU APPROVED TYRE ONLY .....	Part No. 834437 .....	2-11
10- DANGER OF CRUSHING HANDS .....	Part No. 676988 .....	2-12
11- DANGER KEEP AWAY .....	Part No. 679450 .....	2-12
12- DANGER OF CRUSHING .....	Part No. 679452 .....	2-12
13- DANGER OF CRUSHING .....	Part No. 52621082 .....	2-12
14- DANGER ROTATING PART .....	Part No. 683108 .....	2-12
15- DANGER ROTATING PART .....	Part No. 52621210 .....	2-12
16- DANGER HOT COMPONENT .....	Part No. 683112 .....	2-12
17- DANGER HOT COMPONENT .....	Part No. 52621201 .....	2-12
18- DANGER OF BURNS .....	Part No. 52621211 .....	2-13
19- SAFETY STRUT .....	Part No. 678424 .....	2-13
20- WASHING INSTRUCTION .....	Part No. 313672 .....	2-13
21- WASHING INSTRUCTION .....	Part No. 52621093 .....	2-13
22- SAFETY HARNESS ATTACHMENT POINT .....	Part No. 834438 .....	2-13
23- BACKUP PUMP .....	Part No. 52658821 .....	2-13
24- EMERGENCY CONTROL PROCEDURE .....	Part No. 831465 .....	2-14
25- EMERGENCY CONTROL PROCEDURE .....	Part No. 866753 .....	2-14
26- ANCHORING POINT .....	Part No. 833041 .....	2-14
27- ANCHORING 160 ATJ .....	Part No. 52579614 .....	2-14
28- ANCHORING 180 ATJ .....	Part No. 52589806 .....	2-14
29- LIFTING POINT .....	Part No. 833291 .....	2-15
30- LIFTING 160 ATJ .....	Part No. 52708469 .....	2-15
31- LIFTING 180 ATJ .....	Part No. 52708470 .....	2-15
32- INSTRUCTION MANUAL LOCATION .....	Part No. 52562839 .....	2-15
33- HYDRAULIC OIL .....	Part No. 597652 .....	2-15
34- BIODIESEL .....	Part No. 52603134 .....	2-16
35- ANTIFREEZE .....	Part No. 52501046 .....	2-16
36- BATTERY LOCATION .....	Part No. 52509705 .....	2-16
37- POWER FUSES .....	Part No. 52571680 .....	2-16
38- FAULT CODES .....	Part No. 52579619 .....	2-16
39- BATTERY CUT-OFF (OPTION) .....	Part No. 598894 .....	2-17
40- SPECIFIC BATTERY CUT-OFF (OPTION) .....	Part No. 52603132 .....	2-17
41- HYDRAULIC OIL HEATER (OPTION) .....	Part No. 52633500 .....	2-17
42- ENGINE BLOCK HEATER (OPTION) .....	Part No. 831342 .....	2-17
43- BATTERY HEATER (OPTION) .....	Part No. 52633504 .....	2-17
44- POWER SUPPLY FOR 230 V SOCKET IN THE PLATFORM (OPTION) .....	Part No. 518548 .....	2-18
45- 230 V ELECTRICAL SYSTEM (OPTION) .....	Part No. 52679004 .....	2-18
46- ELECTRICAL HAZARD (OPTION) .....	Part No. 678451 .....	2-18



647909 (A112020)  
 160 ATJ 4RD ST5 S2 / 160 ATJ RC 4RD ST5 S2  
 180 ATJ 4RD ST5 S2 / 180 ATJ RC 4RD ST5 S2

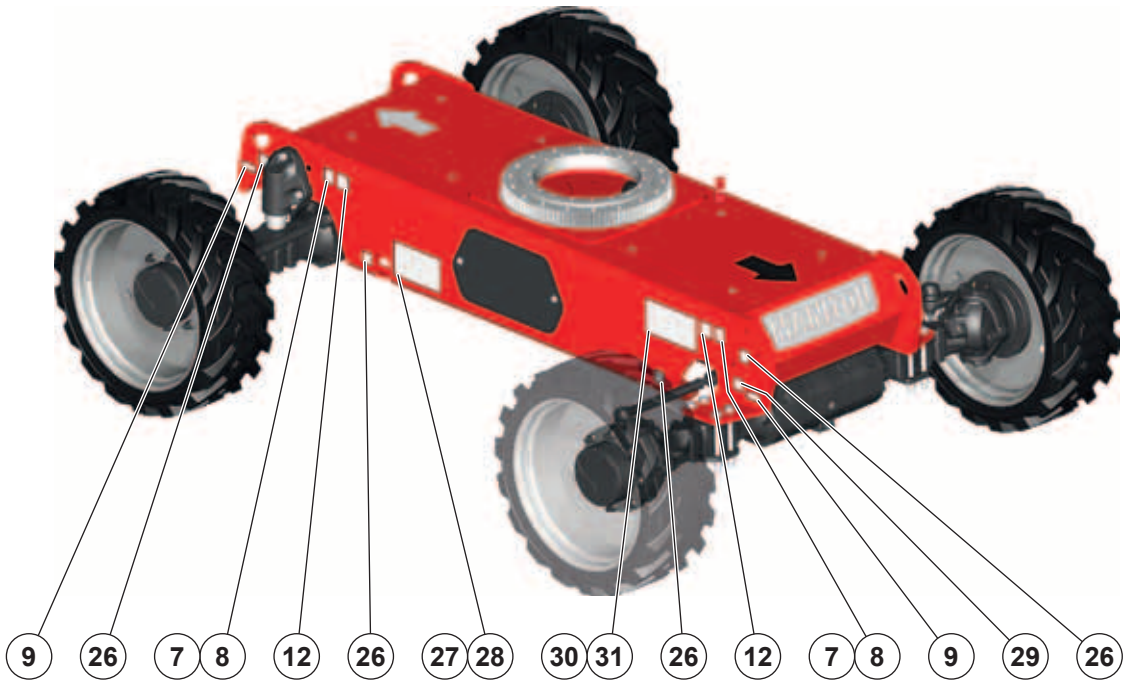
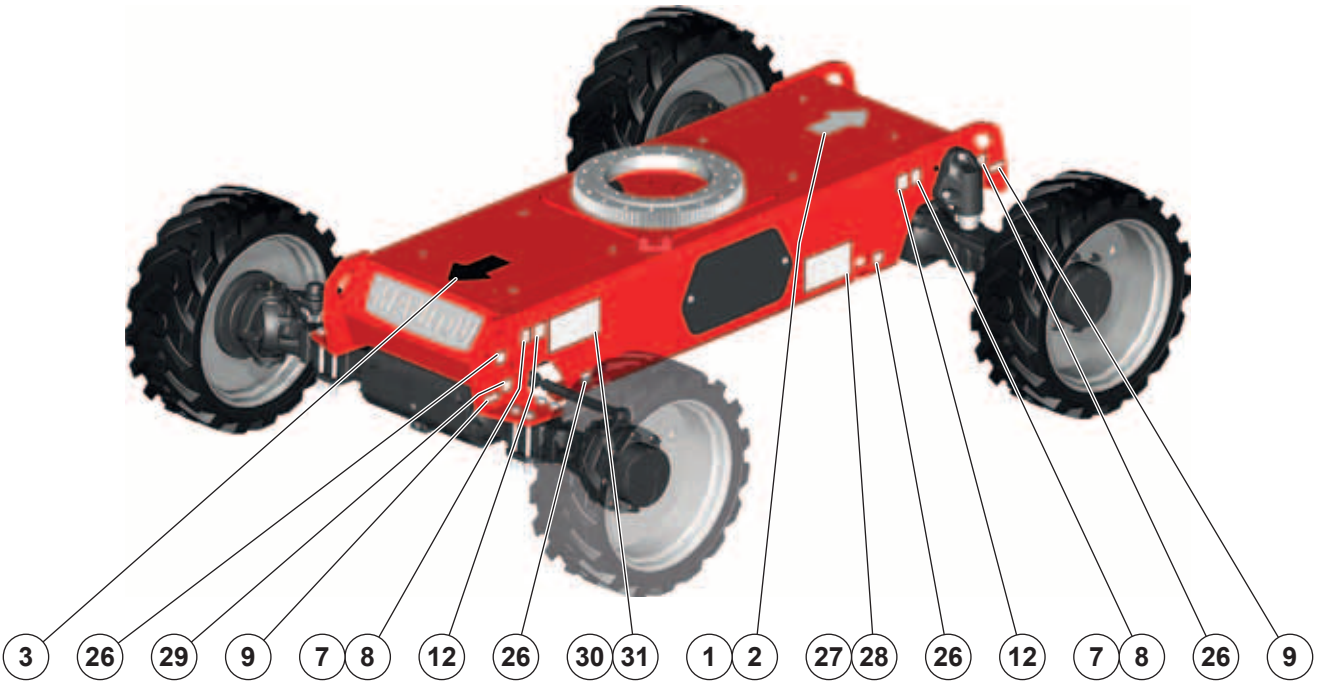

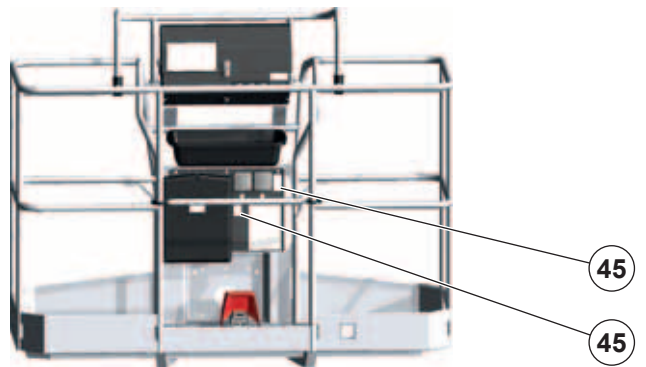
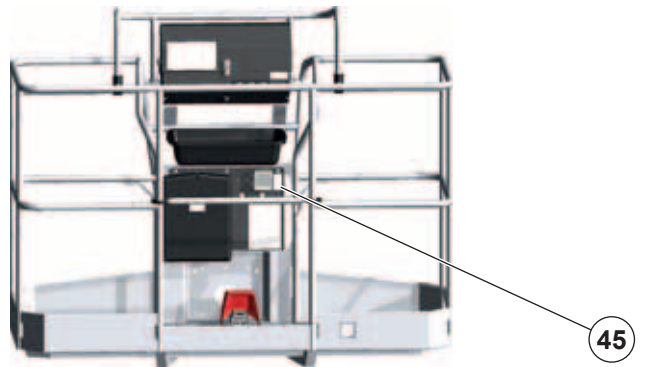
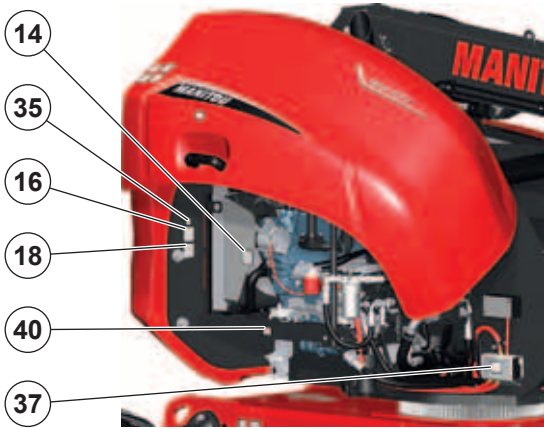
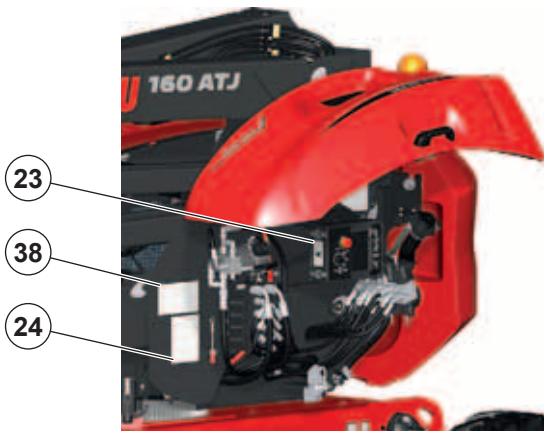

### 1- WHITE ARROW (STANDARD)

**Part No. 833553**

Indicates the forward direction of travel when the turntable and the platform are in neutral position, <img alt="White arrow symbol" data-bbox="195 82 210 97"/> OPERATING THE MACHINE: TRANSPORT/WORKING POSITION.

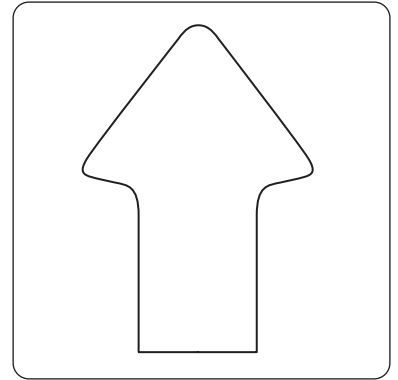

### 2- WHITE ARROW WITH BLACK OUTLINE (OPTION)

**Part No. 52588045**

Indicates the forward direction of travel when the turntable and the platform are in neutral position, <img alt="White arrow with black outline symbol" data-bbox="195 267 210 282"/> OPERATING THE MACHINE: TRANSPORT/WORKING POSITION.

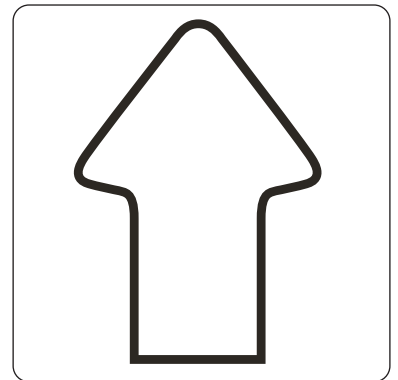

### 3- BLACK ARROW

**Part No. 833554**

Indicates the backward direction of travel when the turntable and the platform are in neutral position, <img alt="Black arrow symbol" data-bbox="195 452 210 467"/> OPERATING THE MACHINE: TRANSPORT/WORKING POSITION.

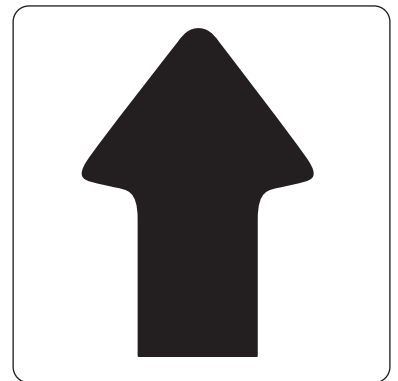

### 4- PLATFORM SAFETY INSTRUCTIONS

**Part No. 676814**

Indicates:

- ① That the instruction manual must be read before using the machine.
- ② Whether the machine can be operated outside and inside.
- ③ The maximum manual force.
- ④ The maximum load capacity in the platform.
- ⑤ The maximum wind speed when operating outside.
- ⑥ Maximum chassis tilt in working position.
- ⑦ The risk of electric shock.

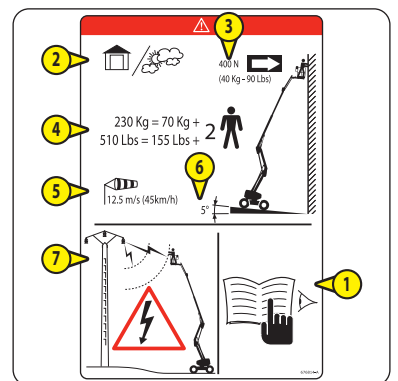

**5- ELECTRICAL SAFETY DISTANCES**

**Part No. 834436**

Indicates the different areas in which the platform can be operated close to electrical power lines.

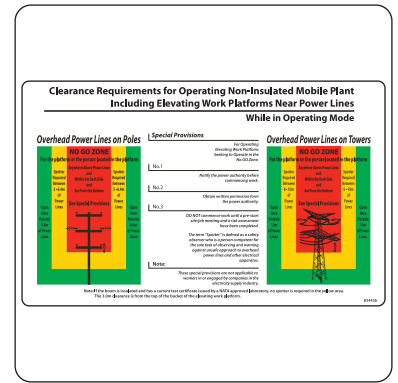

**6- GROUND SAFETY INSTRUCTIONS**

**Part No. 52621077**

Indicates:

- ① That the instruction manual must be read before using the machine.
- ② That the machine must not be towed in the event of breakdown.
- ③ It is strictly forbidden to direct a pressure washer nozzle over the control panels and electrical components.

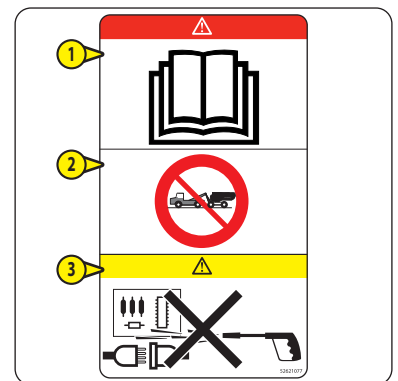

**7- WHEEL LOAD 160 ATJ**

**Part No. 683963**

Indicates the maximum ground load per wheel.



**8- WHEEL LOAD 180 ATJ**

**Part No. 313819**

Indicates the maximum ground load per wheel.

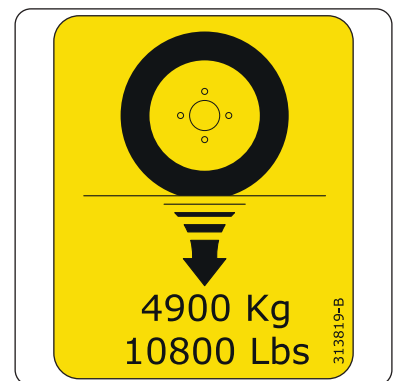

**9- USE MANITOU APPROVED TYRE ONLY**

**Part No. 834437**

Indicates that the operator is using the tyres specified by Manitou.

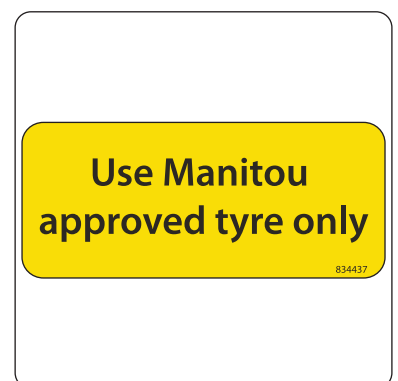

647909 (A112020)  
160 ATJ 4RD ST5 S2 / 160 ATJ RC 4RD ST5 S2  
180 ATJ 4RD ST5 S2 / 180 ATJ RC 4RD ST5 S2

**10- DANGER OF CRUSHING HANDS**

**Part No. 676988**

Indicates that it is strictly forbidden to place your hands or any other part of the body in the lifting mechanism components.



**11- DANGER KEEP AWAY**

**Part No. 679450**

Indicates that it is strictly forbidden to stand under the lifting mechanism or within the machine's working area.



**12- DANGER OF CRUSHING**

**Part No. 679452**

**13- DANGER OF CRUSHING**

**Part No. 52621082**

Indicates that it is strictly prohibited to stand in this area when the machine is moving. The components on which this sticker is affixed could crush you.



**14- DANGER ROTATING PART**

**Part No. 683108**

**15- DANGER ROTATING PART**

**Part No. 52621210**

Indicates that there is a high risk of severing fingers with the radiator fan.



**16- DANGER HOT COMPONENT**

**Part No. 683112**

**17- DANGER HOT COMPONENT**

**Part No. 52621201**

Indicates that there is a high risk of burns in the vicinity.



647909 (A112020)  
160 ATJ 4RD ST5 S2 / 160 ATJ RC 4RD ST5 S2  
180 ATJ 4RD ST5 S2 / 180 ATJ RC 4RD ST5 S2

**18- DANGER OF BURNS**

**Part No. 52621211**

Indicates that there is a significant risk of a spray of steam or boiling-hot liquid being released when turning the radiator filler cap.



**19- SAFETY STRUT**

**Part No. 678424**

Indicates that the safety strut must be used when working under the secondary arm in the raised position, <math>\triangleleft</math> 3 - MAINTENANCE: OCCASIONAL OPERATIONS.

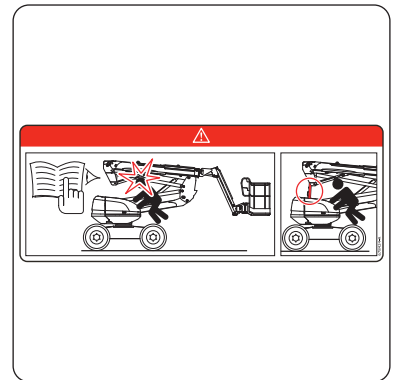

**20- WASHING INSTRUCTION**

**Part No. 313672**

**21- WASHING INSTRUCTION**

**Part No. 52621093**

Indicates that it is strictly forbidden to direct a high pressure cleaner nozzle over the control panels and electrical components or on the diesel engine air intake.

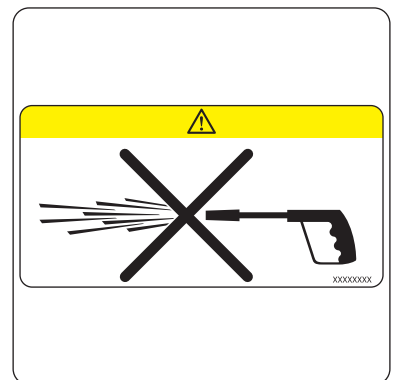

**22- SAFETY HARNESS ATTACHMENT POINT**

**Part No. 834438**

Indicates the location of the safety harness attachment points, <math>\triangleleft</math> SAFETY COMPONENTS: SAFETY HARNESS ATTACHMENT POINTS.



**23- BACKUP PUMP**

**Part No. 52658821**

Indicates the procedure to be followed for using the backup pump, <math>\triangleleft</math> EMERGENCY CONTROLS.

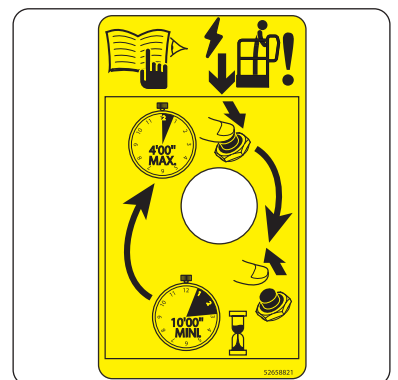

647909 (A112020)  
160 ATJ 4RD ST5 S2 / 160 ATJ RC 4RD ST5 S2  
180 ATJ 4RD ST5 S2 / 180 ATJ RC 4RD ST5 S2

**24- EMERGENCY CONTROL PROCEDURE**

**Part No. 831465**

Indicates the procedure to be followed for using the emergency controls for the proportional distributor, EMERGENCY CONTROLS.



**25- EMERGENCY CONTROL PROCEDURE**

**Part No. 866753**

Indicates the procedure to be followed for using the emergency controls for the proportional distributor, EMERGENCY CONTROLS.

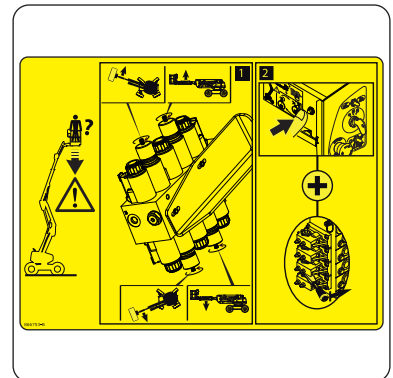

**26- ANCHORING POINT**

**Part No. 833041**

Indicates the location of the machine's anchoring points, TRANSPORT AND LIFTING: TRANSPORT INSTRUCTIONS.

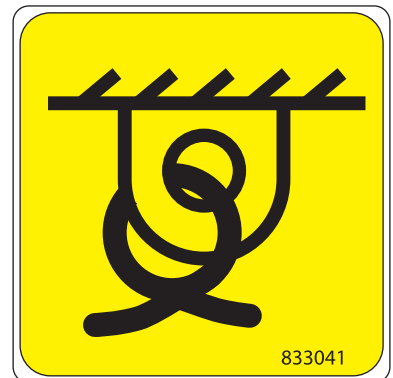

**27- ANCHORING 160 ATJ**

**Part No. 52579614**

Indicates the main features that are useful when anchoring the machine, TRANSPORT AND LIFTING: TRANSPORT INSTRUCTIONS.

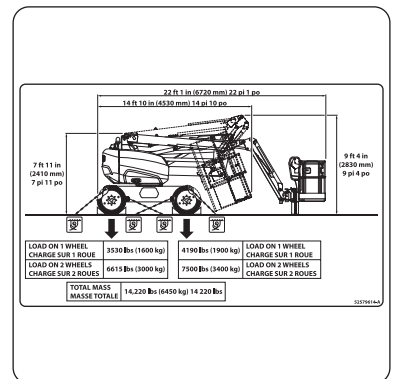

**28- ANCHORING 180 ATJ**

**Part No. 52589806**

Indicates the main features that are useful when anchoring the machine, TRANSPORT AND LIFTING: TRANSPORT INSTRUCTIONS.

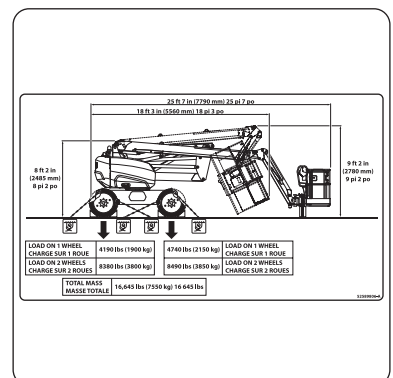

647909 (A112020)  
160 ATJ/4RD ST5 S2 / 160 ATJ RC 4RD ST5 S2  
180 ATJ/4RD ST5 S2 / 180 ATJ RC 4RD ST5 S2

**29- LIFTING POINT**

**Part No. 833291**

Indicates the location of the machine's lifting points,  TRANSPORT AND LIFTING: LIFTING INSTRUCTIONS.

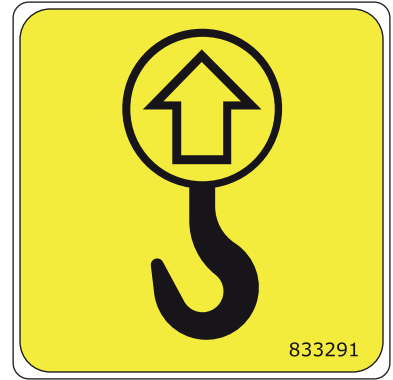

**30- LIFTING 160 ATJ**

**Part No. 52708469**

Indicates the main specifications that are useful when lifting the machine,  TRANSPORT AND LIFTING: LIFTING INSTRUCTIONS.

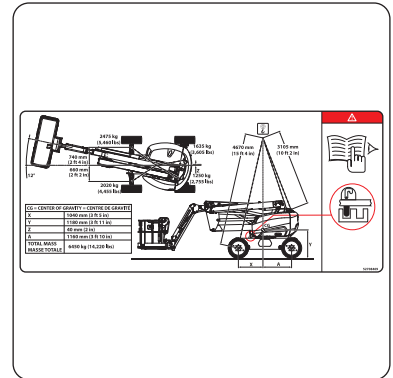

**31- LIFTING 180 ATJ**

**Part No. 52708470**

Indicates the main specifications that are useful when lifting the machine,  TRANSPORT AND LIFTING: LIFTING INSTRUCTIONS.

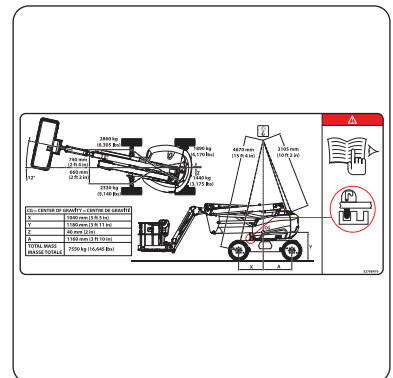

**32- INSTRUCTION MANUAL LOCATION**

**Part No. 52562839**

Indicates location of the instructions for use.



**33- HYDRAULIC OIL**

**Part No. 597652**

This indicates that the tank is intended to contain only hydraulic oil.

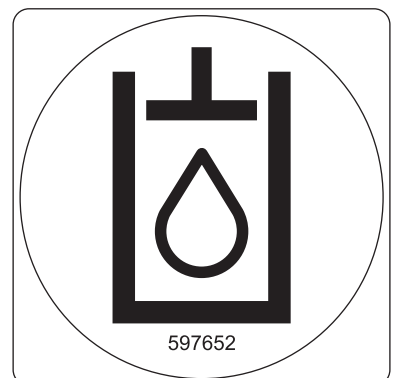

647909 (A112020)  
160 ATJ / 4RD ST5 S2 / 160 ATJ RC 4RD ST5 S2  
180 ATJ / 4RD ST5 S2 / 180 ATJ RC 4RD ST5 S2

**34- BIODIESEL**

**Part No. 52603134**

Indicates that the tank is intended to contain only diesel fuel and biodiesel fuel with concentration up to 7%.

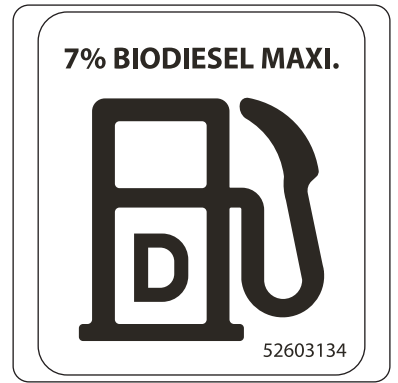

**35- ANTIFREEZE**

**Part No. 52501046**

Indicates that there is antifreeze in the diesel engine radiator.

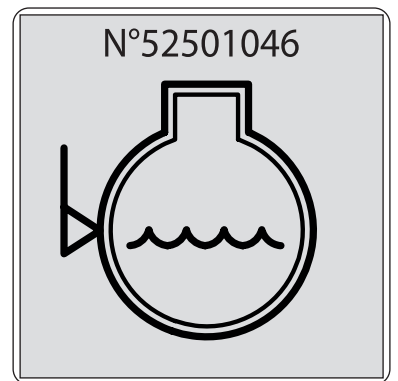

**36- BATTERY LOCATION**

**Part No. 52509705**

Indicates location of battery.

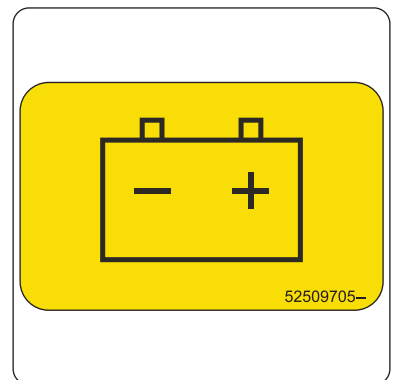

**37- POWER FUSES**

**Part No. 52571680**

Indicates the location, amperage and allocation of power fuses.

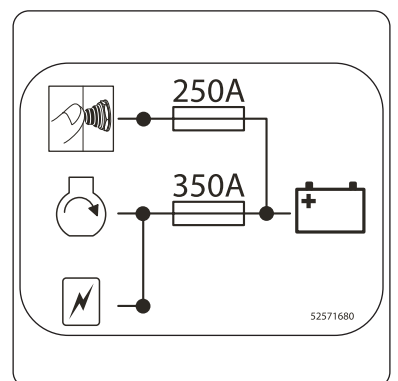

**38- FAULT CODES**

**Part No. 52579619**

Indicates the fault codes and location of the electrical components:

- Sensors (AS, DS, IS, TS).
- Solenoid valves (EV).
- Solenoid coils (EW).

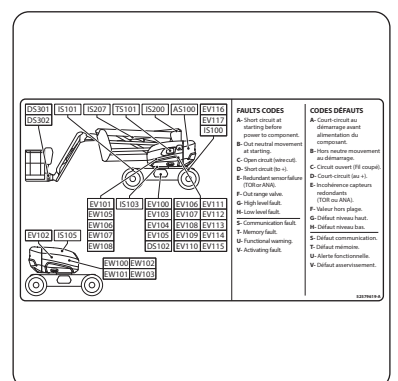

647909 (A112020)  
160 ATJ 4RD ST5 S2 / 160 ATJ RC 4RD ST5 S2  
180 ATJ 4RD ST5 S2 / 180 ATJ RC 4RD ST5 S2

**39- BATTERY CUT-OFF (OPTION)**

**Part No. 598894**

Indicates the location, the off position "OFF" and the on position "ON" of the battery cut-off.

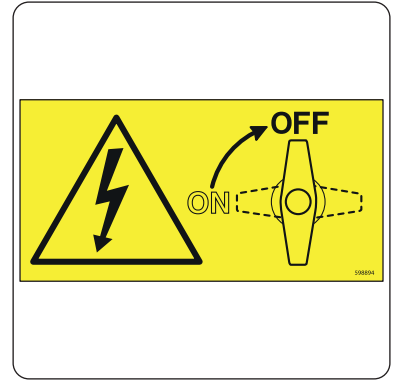

**40- SPECIFIC BATTERY CUT-OFF (OPTION)**

**Part No. 52603132**

Indicates the location of the specific battery cut-off.

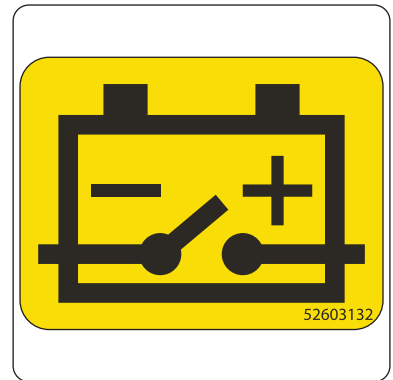

**41- HYDRAULIC OIL HEATER (OPTION)**

**Part No. 52633500**

Indicates:

- The location of the hydraulic oil heater plug.
- ① That the diesel engine must be stopped and that the operator's manual should be read before connecting the hydraulic oil heater.
- ② The voltage of the power source.

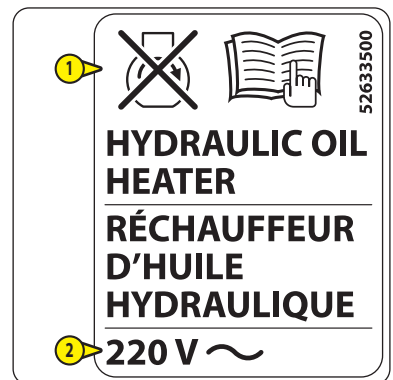

**42- ENGINE BLOCK HEATER (OPTION)**

**Part No. 831342**

Indicates:

- The location of the engine block heater plug.
- ① The voltage and the amperage of the power source and that the electrical system is protected by a 30 mA residual-current circuit breaker.
- ② That the diesel engine must be stopped before connecting the engine block heater.

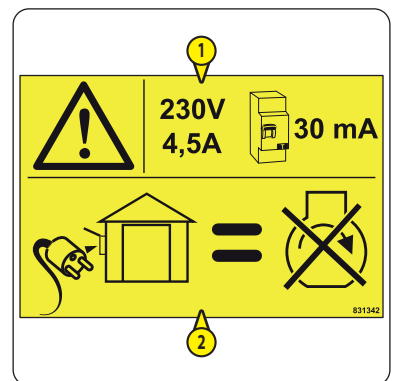

**43- BATTERY HEATER (OPTION)**

**Part No. 52633504**

Indicates:

- The location of the battery heater plug.
- ① That the diesel engine must be stopped and that the operator's manual should be read before connecting the battery heater.
- ② The voltage of the power source.

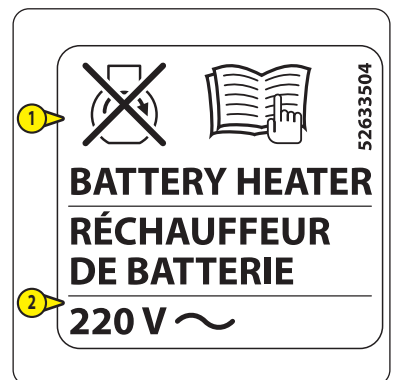

647909 (A112020)  
160 ATJ 4RD ST5 S2 / 160 ATJ RC 4RD ST5 S2  
180 ATJ 4RD ST5 S2 / 180 ATJ RC 4RD ST5 S2

**44- POWER SUPPLY FOR 230 V SOCKET IN THE PLATFORM (OPTION) Part No. 518548**

Indicates:

- ① The voltage and the amperage of the power source.
- ② That the electrical system is protected by a 30 mA residual-current circuit breaker.
- ③ The cross-section of the cables in the electrical system.

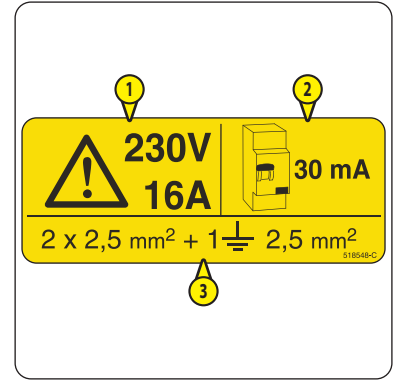

**45- 230 V ELECTRICAL SYSTEM (OPTION) Part No. 52679004**

Indicates:

- ① The voltage and the amperage of the electrical system.
- ② That the electrical system is protected by a 30 mA residual-current circuit breaker.
- ③ The cross-section of the cables in the electrical system.

Note:

- For 230 V 3.5 kW electric generator option (quantity = 1).
- For 230 V 5 kW electric generator option (quantity = 2).

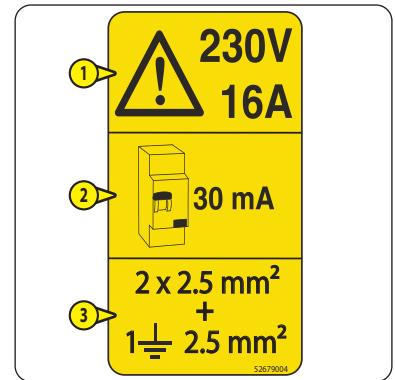

**46- ELECTRICAL HAZARD (OPTION) Part No. 678451**



Indicates an electrical hazard.

Note:

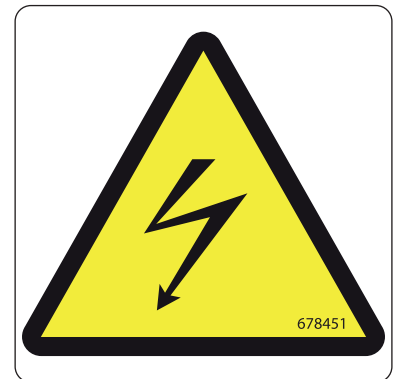
- For 230 V 3.5 kW electric generator option.
- For 230 V 5 kW electric generator option.



## SPECIFICATIONS 160 ATJ

GENERAL CHARACTERISTICS			±
<b>Machine</b>			
- Maximum load capacity the platform.	kg (lbs)	230 (507)	-
- Maximum wind speed when operating outside	km/h	45	-
- Maximum number of people in the platform (indoor use/ outdoor use)		2 / 2	-
- Machine weight, unladen (standard wheels OTR OUTRIGGER XT 33X12 D610 NHS)	kg (lbs)	6,160 (13,580)	2%
- Machine weight, unladen (optional wheels OTR OUTRIGGER XT 36X15 D610 NHS)	kg (lbs)	6,430 (14,180)	2%
- Maximum authorized chassis tilt in working position	°	5	0.1%
- Maximum slope in transport position:			
1- Platform at the bottom of the slope with 100 kg (220 lbs) in the platform (surmountable slope)	 %	45	2
2- Platform at the top of the slope	 %	45	-
3- Lateral slope	 %	25	-
- Maximum manual force	N	400	-
<b>Standard wheels OTR OUTRIGGER XT 33X12 D610 NHS</b>			
- Load on one front wheel (transport position)	kg (lbs)	1,465 (3,230)	2%
- Load on one rear wheel (transport position)	kg (lbs)	1,615 (3,560)	2%
- Maximum load on one wheel (working position)	kg (lbs)	3,740 (8,245)	2%
- Bearing surface on ground (hard/soft)	cm <sup>2</sup>	344 / 728	5%
- Ground bearing pressure (hard/soft)	daN/cm <sup>2</sup>	11.6 / 5.5	5%
<b>Optional wheels OTR OUTRIGGER XT 36X15 D610 NHS</b>			
- Load on one front wheel (transport position)	kg (lbs)	1,540 (3,395)	2%
- Load on one rear wheel (transport position)	kg (lbs)	1,690 (3,726)	2%
- Maximum load on one wheel (working position)	kg (lbs)	3,910 (8,620)	2%
- Bearing surface on ground (hard/soft)	cm <sup>2</sup>	482 / 980	5%
- Ground bearing pressure (hard/soft)	daN/cm <sup>2</sup>	8.3 / 4.1	5%

<b>SPEEDS AND MOVEMENTS</b>			<b>±</b>
Travel speeds			
- Working speed	km/h	1	0.1
- Slow speed	km/h	2.5	0.5
- Ramp speed	km/h	2.5	0.2
- Hare speed (standard wheels OTR OUTRIGGER XT 33X12 D610 NHS)	km/h	5	0.2
- Hare speed (optional wheels OTR OUTRIGGER XT 36X15 D610 NHS)	km/h	5.5	0.2
Main arm (telescopic arm extended)			
- Lifting speed (unladen/laden)	s	20 / 20	1
- Lowering speed (unladen/laden)	s	18 / 18	1
Main arm (telescopic arm retracted)			
- Lifting speed (unladen/laden)	s	14 / 14	2
- Lowering speed (unladen/laden)	s	14 / 14	2
Secondary arm			
- Lifting speed (unladen/laden)	s	22 / 22	1
- Lowering speed (unladen/laden)	s	30 / 30	4
Telescopic arm			
- Extended (unladen/laden)	s	9 / 9	1
- Retracted (unladen/laden)	s	9 / 9	1
Jib arm			
- Lifting speed (unladen/laden)	s	20 / 20	1
- Lowering speed (unladen/laden)	s	18 / 18	1
Turntable			
- 350° rotation (telescopic arm extended/retracted)	s	90 / 70	5
Platform			
- Rotation to the right / to the left	s	13 / 13	2

<b>DIESEL ENGINE</b>			<b>±</b>
Type		KUBOTA D1105-E4B	-
Fuel		Diesel	-
Number of cylinders		3	-
Cubic capacity	cm <sup>3</sup>	1,123	-
Idling speed unladen	rpm	1,300	20
Maximum speed unladen	rpm	3,000	40
Power at 3,000 rpm	kW	18.5	-
Maximum torque at 2,200 rpm	N.m	72	-
Unladen weight	kg (lbs)	93 (205)	5 (11)
Type of cooling		Coolant	-
Fan		Puller	-
Emissions			
- CO (carbon monoxide)	g/kWh	1.4	-
- HC + Nox (hydrocarbons + nitrogen dioxide)	g/kWh	5.8	-
- PT (particles)	g/kWh	0.21	-

<b>TRANSMISSION</b>			<b>±</b>
Hydrostatic pump			
- Type		BOSCH REXROTH A10VG45	-
- Maximum cylinder capacity	cm <sup>3</sup>	46	-
- Maximum unladen flow rate	L/min	115	-
- Maximum pressure	bar	340	-
Hydrostatic motor			
- Type		BOSCH REXROTH	-
- Cubic capacity	cm <sup>3</sup>	63	-
Axles			
- Type		DANA SPICER	-
- Reduction ratio		55.9	-
- Traction force (standard wheels OTR OUTRIGGER XT 33X12 D610 NHS)	daN	3,890	-
- Traction force (optional wheels OTR OUTRIGGER XT 36X15 D610 NHS)	daN	3,540	-
- Front axle differential		45% limited slip	-
- Rear axle differential		100% hydraulic locking	-
Front / rear steering/directional wheels		2 / 2	-
Front / rear drive wheels		2 / 2	-
Standard wheels			
- Type		OTR OUTRIGGER XT 33X12 D610 NHS	-
- Dimensions (external Ø x width)	mm	834 x 298	-
- Inflation		Foam	-
Optional wheels			
- Type		OTR OUTRIGGER XT 36X15 D610 NHS	-
- Dimensions (external Ø x width)	mm	914 x 377	-
- Inflation		Foam	-

<b>BRAKES</b>			<b>±</b>
Type		Negative	-
Type of control		Hydraulics	-
Front/rear braked wheels		0 / 2	-
Brake release (freewheeling)		Manual	-
Braking torque	daN.m	1,600 on wheel	5%

<b>HYDRAULIC CIRCUIT</b>			<b>±</b>
Auxiliary hydraulic pump			
- Type		BOSCH	-
- Maximum cylinder capacity	cm <sup>3</sup>	18	-
- Maximum unladen flow rate	L/min	54	-
Distributor			
- Type		DANFOSS	-
- Maximum pressure	bar	210	5
Turntable rotation motor			
- Type		BONFIGLIOLI	-
- Reduction ratio		1:7.2	-
Filtration			
- Suction	µm	125	-
- Pressure	µm	10	-
- Operation	µm	10	-

<b>ELECTRICAL SYSTEM</b>			<b>±</b>
Battery (original equipment)			
- Type		EXIDE	-
- Capacity C5	Ah	110	-
- Capacity C20	Ah	-	-
- Rated voltage	V	12	-
Alternator			
- Type		SUMITOMO	-
- Maximum current	A	60	-
- Rated voltage	V	12	-
Starter			
- Type		Electric	-
- Power	kW	2	-
- Voltage	V	12	-

<b>BACKUP PUMP</b>			<b>±</b>
- Type		Electric	-
- Cubic capacity	cm <sup>3</sup>	2	-
- Power	kW	1.3	-
- Voltage	V	12	-
- Pressure 150 bars	A	-	-

<b>DIMENSIONS</b>			<b>±</b>
Working height = maximum height of the platform floor (H2) + 2,000 mm (standard wheels OTR OUTRIGGER XT 33X12 D610 NHS)	mm	16,015	1%
Working height = maximum height of the platform floor (H2) + 2,000 mm (optional wheels OTR OUTRIGGER XT 36X15 D610 NHS)	mm	16,055	1%
Working reach = max. reach (D1) + 500 mm	mm	8,295	1%
Standard platform			
- External dimensions (length x width)	mm	1,800 x 800	1%
- Floor dimensions (length x width)	mm	1,790 x 760	1%
Wide platform without gate (option) and wide platform with gate (option)			
- External dimensions (length x width)	mm	2,100 x 800	1%
- Floor dimensions (length x width)	mm	2,090 x 760	1%
Angle of rotation of the platform to the left / to the right	°	90 / 90	1%
Upward and downward angle of deflection of the jib arm	°	65 / 59.5	1%
Turntable rotation angle (160 ATJ 4RD ST5 S2)	°	350	1%
Turntable rotation angle (160 ATJ 4RD RC ST5 S2)	°	Continuous rotation	-
Other dimensions: <img alt="arrow pointing left" data-bbox="205 618 220 631"/> DIMENSIONS AND AMPLITUDE OF MOVEMENT 160 ATJ.			

<b>NOISE AND VIBRATION</b>			<b>±</b>
Sound power level LwA	dB	105	-
Vibrations affecting body in the platform			
- Average quadratic values for the body	m/s <sup>2</sup>	< 0.5	-



## DIMENSIONS AND AMPLITUDE OF MOVEMENT 160 ATJ

Standard wheels OTR OUTRIGGER XT 33X12 D610 NHS								
<b>A</b>	mm	6,680	<b>D</b>	mm	2,320	<b>G2</b>	mm	6,100 (1) / 6,180 (2)
<b>A1</b>	mm	4,445 (1) / 4,490 (2)	<b>E</b>	mm	360	<b>I</b>	mm	220
<b>B</b>	mm	2,200	<b>E2</b>	mm	260	<b>J</b>	mm	2,770
<b>B1</b>	mm	1,100	<b>F</b>	mm	450	<b>K</b>	°/%	37.6 / 77
<b>C</b>	mm	2,370	<b>G</b>	mm	1,380			
<b>C1</b>	mm	2,630 (1) / 2,830 (2)	<b>G1</b>	mm	3,750			

Optional wheels OTR OUTRIGGER XT 36X15 D610 NHS								
<b>A</b>	mm	6,720	<b>D</b>	mm	2,320	<b>G2</b>	mm	6,100 (1) / 6,180 (2)
<b>A1</b>	mm	4,485 (1) / 4,530 (2)	<b>E</b>	mm	400	<b>I</b>	mm	220
<b>B</b>	mm	2,200	<b>E2</b>	mm	300	<b>J</b>	mm	2,770
<b>B1</b>	mm	1,100	<b>F</b>	mm	495	<b>K</b>	°/%	43.5 / 95
<b>C</b>	mm	2,410	<b>G</b>	mm	1,380			
<b>C1</b>	mm	2,690 (1) / 2,810 (2)	<b>G1</b>	mm	3,750			

(1) Standard platform.

(2) Wide platform without gate (option) and wide platform with gate (option).

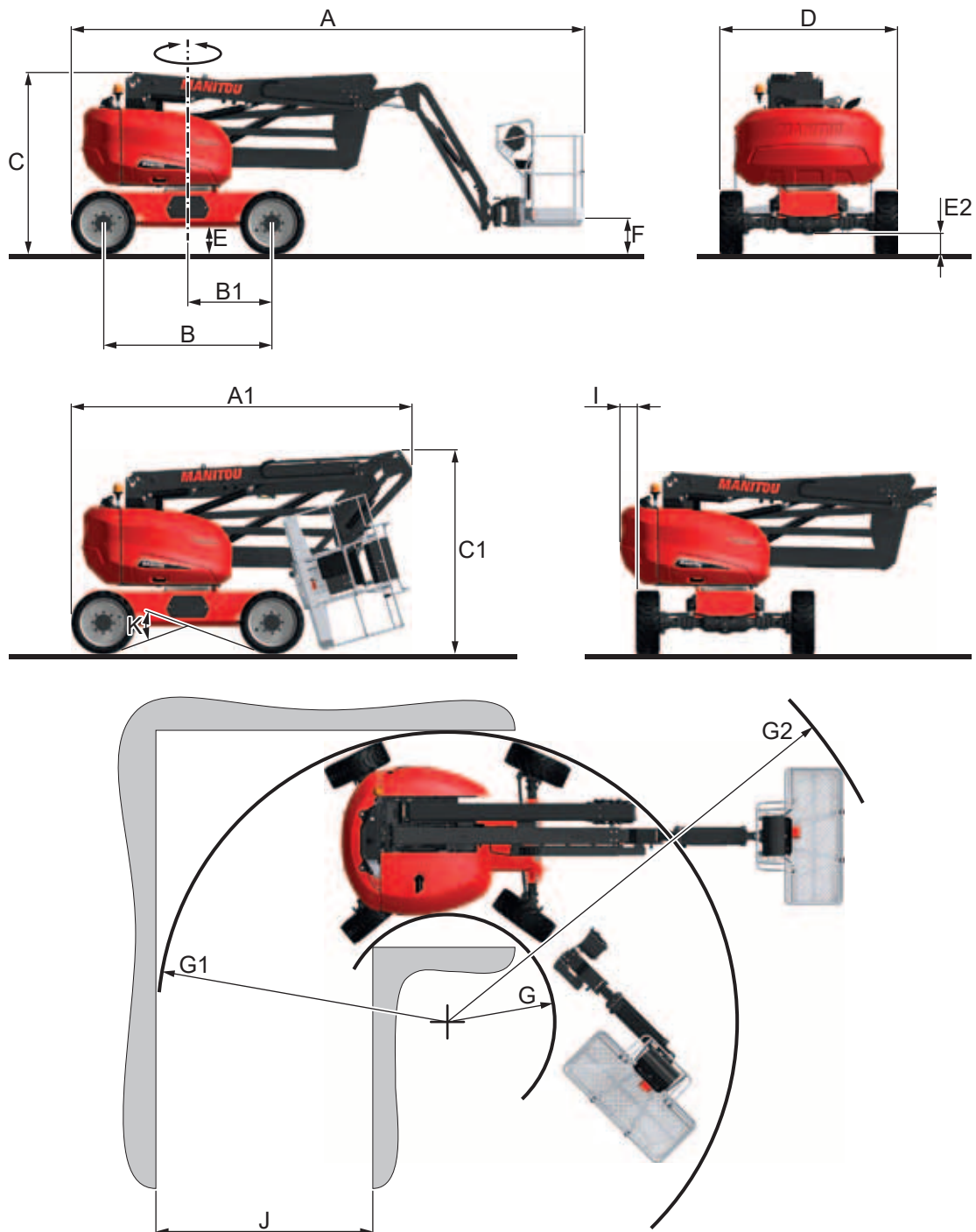

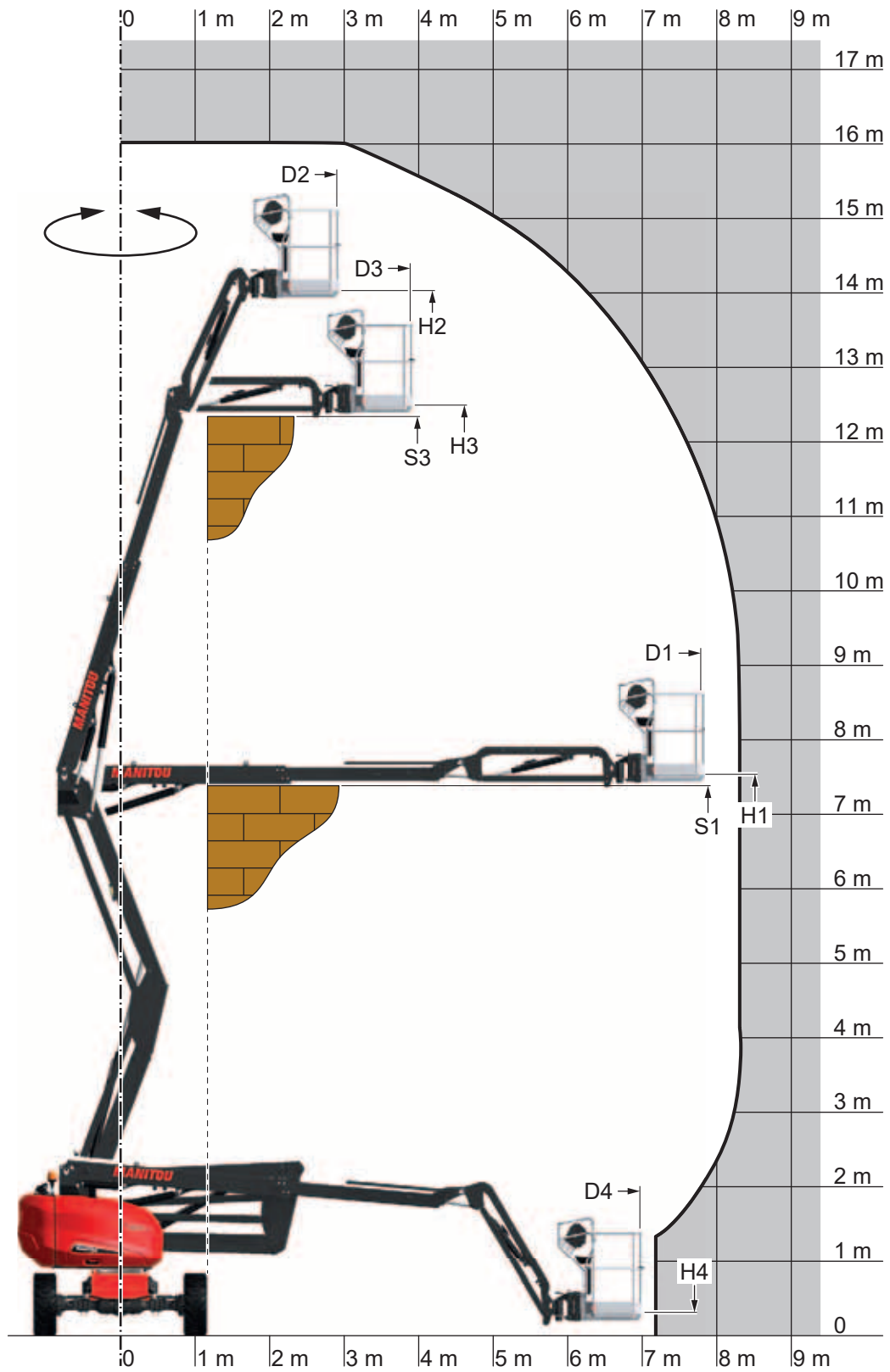

Standard wheels OTR OUTRIGGER XT 33X12 D610 NHS												
<b>H1</b>	mm	7,510	<b>S1</b>	mm	7,365		<b>H3</b>	mm	12,475	<b>S3</b>	mm	12,335
<b>D1</b>	mm	7,795					<b>D3</b>	mm	3,890			
<b>H2</b>	mm	14,015					<b>H4</b>	mm	295			
<b>D2</b>	mm	2,905					<b>D4</b>	mm	6,980			

Optional wheels OTR OUTRIGGER XT 36X15 D610 NHS												
<b>H1</b>	mm	7,550	<b>S1</b>	mm	7,405		<b>H3</b>	mm	12,515	<b>S3</b>	mm	12,375
<b>D1</b>	mm	7,795					<b>D3</b>	mm	3,890			
<b>H2</b>	mm	14,055					<b>H4</b>	mm	335			
<b>D2</b>	mm	2,905					<b>D4</b>	mm	6,980			



647909 (A112020)  
 160 ATJ 4RD ST5 S2 / 160 ATJ RC 4RD ST5 S2  
 180 ATJ 4RD ST5 S2 / 180 ATJ RC 4RD ST5 S2



GENERAL CHARACTERISTICS			±
<b>Machine</b>			
- Maximum load capacity the platform.	kg (lbs)	230 (507)	-
- Maximum wind speed when operating outside	km/h	45	-
- Maximum number of people in the platform (indoor use/ outdoor use)		2 / 2	-
- Machine weight, unladen	kg (lbs)	7,470 (16,470)	2%
- Maximum authorized chassis tilt in working position	°	5	0.1%
- Maximum slope in transport position:			
1- Platform at the bottom of the slope with 100 kg (220 lbs) in the platform (surmountable slope)	 %	45	2
2- Platform at the top of the slope	 %	45	-
3- Lateral slope	 %	25	-
- Maximum manual force	N	400	-
<b>Wheels</b>			
- Load on one front wheel (transport position)	kg (lbs)	1,840 (4,056)	2%
- Load on one rear wheel (transport position)	kg (lbs)	1,935 (4,266)	2%
- Maximum load on one wheel (working position)	kg (lbs)	4,845 (10,681)	2%
- Bearing surface on ground (hard/soft)	cm <sup>2</sup>	487 / 987	5%
- Ground bearing pressure (hard/soft)	daN/cm <sup>2</sup>	10 / 5	5%

SPEEDS AND MOVEMENTS			±
<b>Travel speeds</b>			
- Working speed	km/h	1	0.1
- Slow speed	km/h	2.5	0.5
- Ramp speed	km/h	2.5	0.2
- Hare speed	km/h	5	0.2
<b>Main arm (telescopic arm extended)</b>			
- Lifting speed (unladen/laden)	s	27 / 25	1
- Lowering speed (unladen/laden)	s	25 / 25	1
<b>Main arm (telescopic arm retracted)</b>			
- Lifting speed (unladen/laden)	s	16 / 16	2
- Lowering speed (unladen/laden)	s	15 / 15	2
<b>Secondary arm</b>			
- Lifting speed (unladen/laden)	s	22 / 22	1
- Lowering speed (unladen/laden)	s	30 / 30	4
<b>Telescopic arm</b>			
- Extended (unladen/laden)	s	14 / 14	1
- Retracted (unladen/laden)	s	14 / 14	1
<b>Jib arm</b>			
- Lifting speed (unladen/laden)	s	20 / 20	1
- Lowering speed (unladen/laden)	s	18 / 18	1
<b>Turntable</b>			
- 350° rotation (telescopic arm extended/ retracted)	s	120 / 90	5
<b>Platform</b>			
- Rotation to the right / to the left	s	13 / 13	2

<b>DIESEL ENGINE</b>			<b>±</b>
Type		KUBOTA D1105-E4B	-
Fuel		Diesel	-
Number of cylinders		3	-
Cubic capacity	cm <sup>3</sup>	1,123	-
Idling speed unladen	rpm	1,300	20
Maximum speed unladen	rpm	3,000	40
Power at 3,000 rpm	kW	18.5	-
Maximum torque at 2,200 rpm	N.m	72	-
Unladen weight	kg (lbs)	93 (205)	5 (11)
Type of cooling		Coolant	-
Fan		Puller	-
<b>Emissions</b>			
- CO (carbon monoxide)	g/kWh	1.4	-
- HC + Nox (hydrocarbons + nitrogen dioxide)	g/kWh	5.8	-
- PT (particles)	g/kWh	0.21	-

<b>TRANSMISSION</b>			<b>±</b>
<b>Hydrostatic pump</b>			
- Type		BOSCH REXROTH A10VG45	-
- Maximum cylinder capacity	cm <sup>3</sup>	46	-
- Maximum unladen flow rate	L/min	115	-
- Maximum pressure	bar	340	-
<b>Hydrostatic motor</b>			
- Type		BOSCH REXROTH	-
- Cubic capacity	cm <sup>3</sup>	80	-
<b>Axles</b>			
- Type		DANA SPICER	-
- Reduction ratio		55.9	-
- Pulling force	daN	4,510	-
- Front axle differential		45% limited slip	-
- Rear axle differential		100% hydraulic locking	-
Front / rear steering/directional wheels		2 / 2	-
Front / rear drive wheels		2 / 2	-
<b>Wheels</b>			
- Type		OTR OUTRIGGER XT 36X15 D610 NHS	-
- Dimensions (external Ø x width)	mm	914 x 377	-
- Inflation		Foam	-

<b>BRAKES</b>			<b>±</b>
Type		Negative	-
Type of control		Hydraulics	-
Front/rear braked wheels		0 / 2	-
Brake release (freewheeling)		Manual	-
Braking torque	daN.m	1,600 on wheel	5%

HYDRAULIC CIRCUIT			±
Auxiliary hydraulic pump			
- Type		BOSCH	-
- Maximum cylinder capacity	cm <sup>3</sup>	18	-
- Maximum unladen flow rate	L/min	54	-
Distributor			
- Type		DANFOSS	-
- Maximum pressure	bar	220	5
Turntable rotation motor			
- Type		BONFIGLIOLI	-
- Reduction ratio		1:7.2	-
Filtration			
- Suction	µm	125	-
- Pressure	µm	10	-
- Operation	µm	10	-

ELECTRICAL SYSTEM			±
Battery (original equipment)			
- Type		EXIDE	-
- Capacity C5	Ah	110	-
- Capacity C20	Ah	-	-
- Rated voltage	V	12	-
Alternator			
- Type		SUMITOMO	-
- Maximum current	A	60	-
- Rated voltage	V	12	-
Starter			
- Type		Electric	-
- Power	kW	2	-
- Voltage	V	12	-

BACKUP PUMP			±
- Type		Electric	-
- Cubic capacity	cm <sup>3</sup>	2	-
- Power	kW	1.3	-
- Voltage	V	12	-
- Pressure 150 bars	A	-	-

DIMENSIONS			±
Working height = maximum height of the platform floor (H2) + 2,000 mm	mm	18,180	1%
Working reach = max. reach (D1) + 500 mm	mm	10,510	1%
Standard platform			
- External dimensions (length x width)	mm	1,800 x 800	1%
- Floor dimensions (length x width)	mm	1,790 x 760	1%
Wide platform without gate (option) and wide platform with gate (option)			
- External dimensions (length x width)	mm	2,100 x 800	1%
- Floor dimensions (length x width)	mm	2,090 x 760	1%
Angle of rotation of the platform to the left / to the right	°	90 / 90	1%
Upward and downward angle of deflection of the jib arm	°	65 / 59.5	1%
Turntable rotation angle (180 ATJ 4RD ST5 S2)	°	350	1%
Turntable rotation angle (180 ATJ 4RD RC ST5 S2)	°	Continuous rotation	-
Other dimensions: <math>\triangleleft</math> DIMENSIONS AND AMPLITUDE OF MOVEMENT 180 ATJ.			

NOISE AND VIBRATION			±
Sound power level LwA	dB	105	-
Vibrations affecting body in the platform			
- Average quadratic values for the body	m/s <sup>2</sup>	<0.5	-

## DIMENSIONS AND AMPLITUDE OF MOVEMENT 180 ATJ

<b>A</b>	mm	7,790	<b>D</b>	mm	2,320	<b>G2</b>	mm	7,030 (1) / 7,095 (2)
<b>A1</b>	mm	5,560	<b>E</b>	mm	400	<b>I</b>	mm	220
<b>B</b>	mm	2,200	<b>E2</b>	mm	300	<b>J</b>	mm	3,555 (1) / 3,695 (2)
<b>B1</b>	mm	1,100	<b>F</b>	mm	430	<b>K</b>	°/%	43.5 / 95
<b>C</b>	mm	2,475 (1) / 2,485 (2)	<b>G</b>	mm	1,380			
<b>C1</b>	mm	2,560 (1) / 2,780 (2)	<b>G1</b>	mm	4,535 (1) / 4,675 (2)			

(1) Standard platform.

(2) Wide platform without gate (option) and wide platform with gate (option).

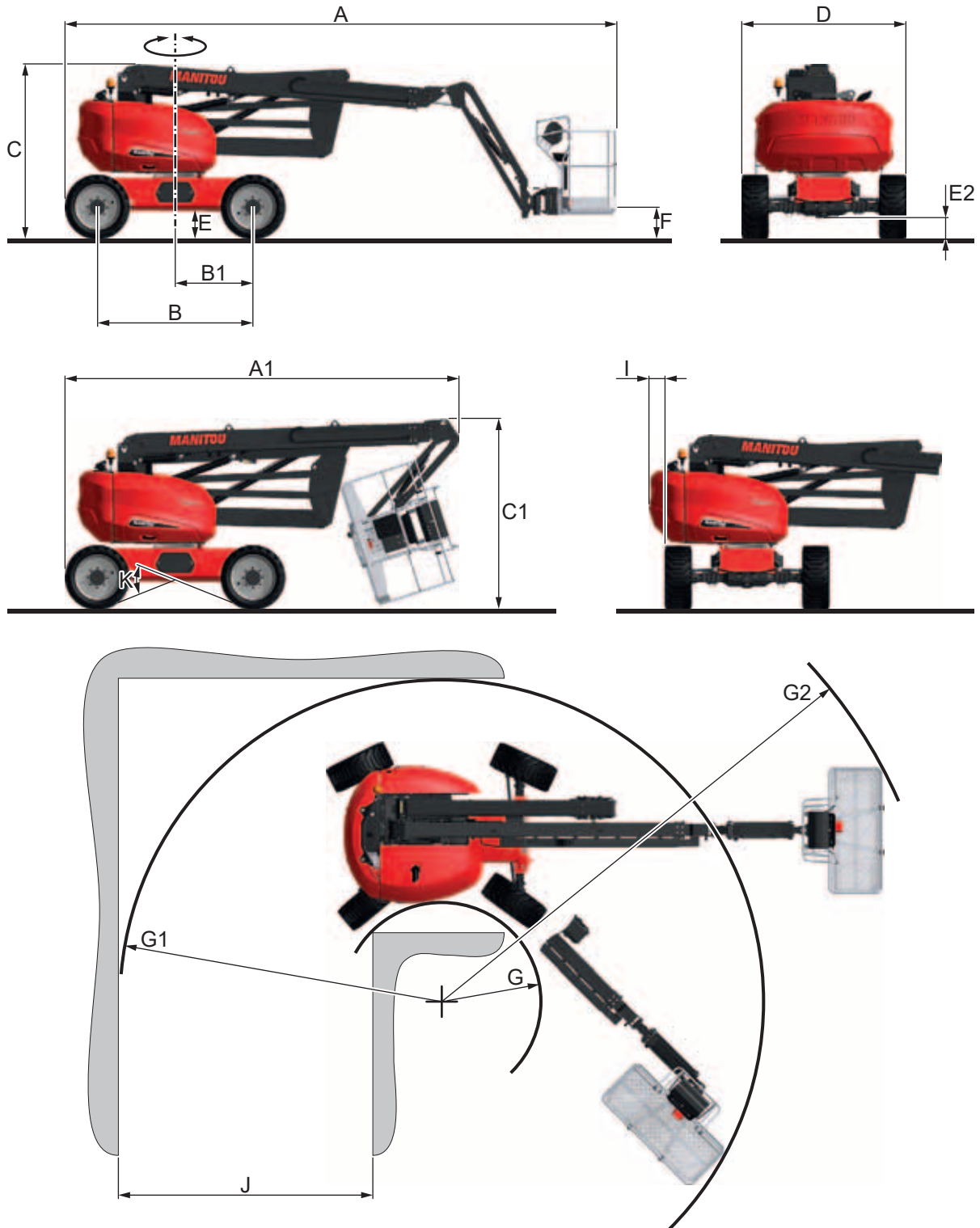

<b>H1</b>	mm	7,555	<b>S1</b>	mm	7,420	<b>H3</b>	mm	14,640	<b>S3</b>	mm	13,350
<b>D1</b>	mm	10,010				<b>D3</b>	mm	4,530			
<b>H2</b>	mm	16,180				<b>H4</b>	mm	185			
<b>D2</b>	mm	3,545				<b>D4</b>	mm	9,190			

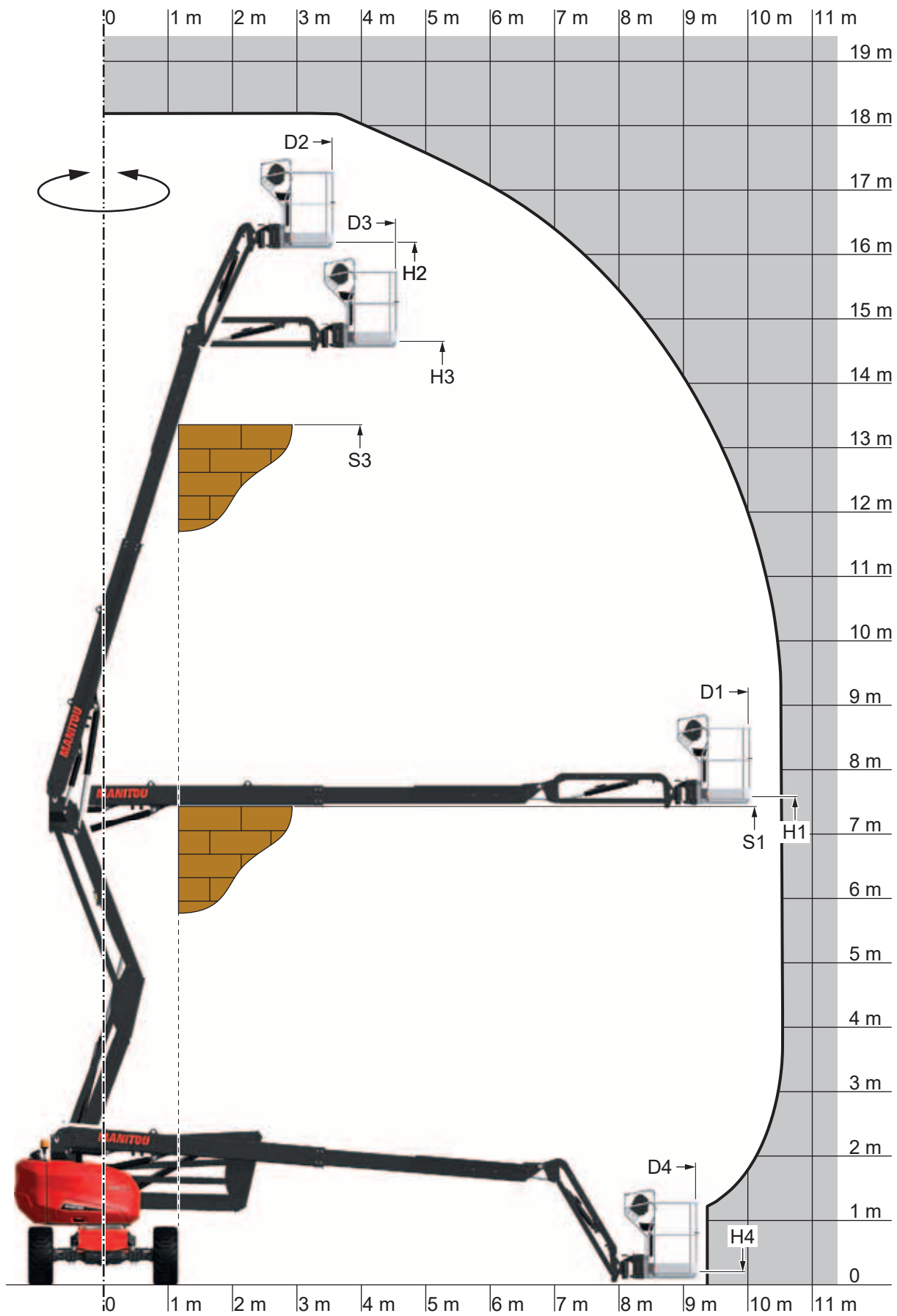

647909 (A112020)  
160 ATJ 4RD ST5 S2 / 160 ATJ RC 4RD ST5 S2  
180 ATJ 4RD ST5 S2 / 180 ATJ RC 4RD ST5 S2

## SAFETY COMPONENTS

### SLIDING MID RAIL

Standard platform and wide platform without gate (option).

**⚠ IMPORTANT ⚠**

*Do not attach the sliding mid rail in the high position.  
Make sure that the sliding mid rail is in the low position before using the machine.*

The platform has a sliding mid rail ①.

- Lift up the sliding mid rail to get into and out of the platform.

Note: the illustration shows a standard platform.

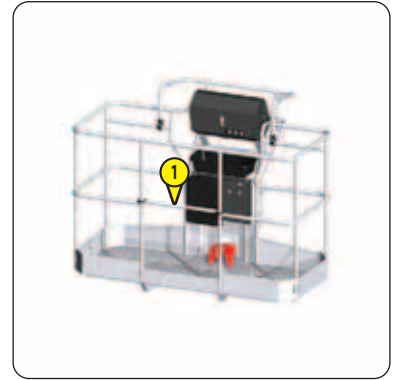

### SLIDING MID RAIL AND GATE

Wide platform with gate (option).

**⚠ IMPORTANT ⚠**

*Do not attach the sliding mid rail in the high position.  
Make sure that the sliding mid rail is in the low position before using the machine.  
Make sure that the gate is properly closed before using the machine.*

The platform has a sliding mid rail ① and a gate ② with a locking handle.

- Lift up the sliding mid rail to get into and out of the platform.

or

- Get into or out of the platform through the gate.

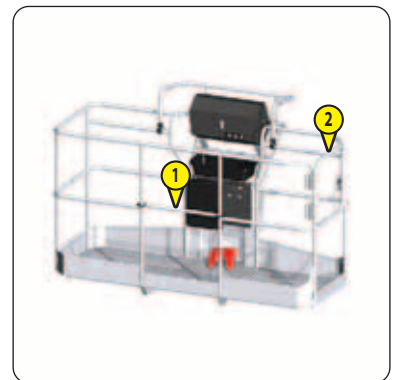

### SAFETY HARNESS ATTACHMENT POINTS

**⚠ IMPORTANT ⚠**

*Only one operator/occupant is permitted to use each attachment point.*

- Attach the safety harnesses to the attachment points ① in the platform.

Note: 2 attachment points, <img alt="arrow icon" data-bbox="288 608 302 622"/> STICKERS: SAFETY HARNESS ATTACHMENT POINTS.

Note: the illustration shows a standard platform.

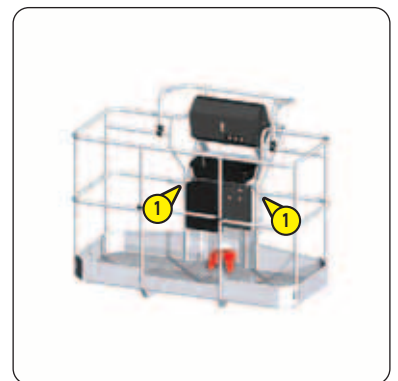

### HANDRAILS

**⚠ IMPORTANT ⚠**

*When using the machine:  
- Do not hold onto the platform guardrails.  
- Hold onto the handrails ①.*

Note: the illustration shows a standard platform.

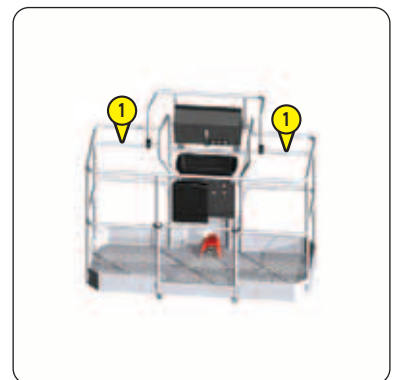

## TURNTABLE LOCKING PIN

Note: the illustrations show a 160 ATJ.

Locking the turntable prevents it from rotating.

Position **A**: the turntable is unlocked.

Position **B**: the turntable is locked.

### LOCK THE TURNTABLE

- Align the locking pin **1** and the chassis notch **2**.
- Pull the locking pin and turn it to the left.
- Push it into the chassis notch (position **B**).

### UNLOCK THE TURNTABLE

- Pull the locking pin **1** and turn it to the right.
- Push it into position **A**.

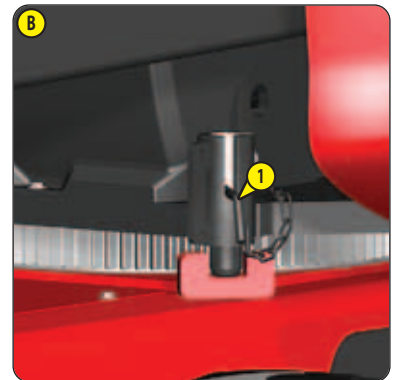
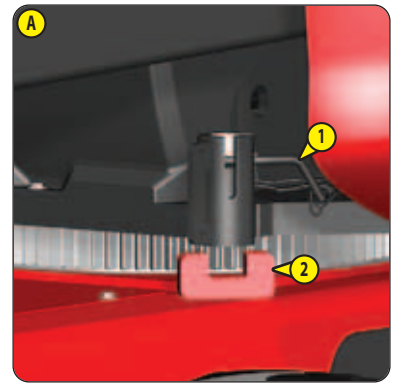

Note: the illustration **C** shows a 160 ATJ with the battery cut-off option.

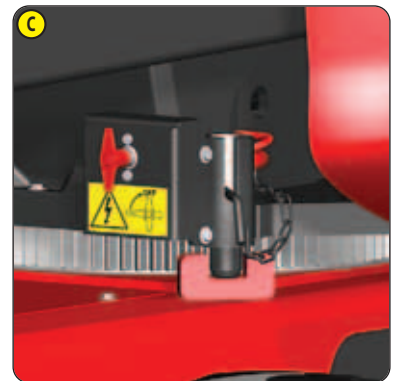

Note: ⚠ TRANSPORT AND LIFTING: LIFTING INSTRUCTIONS for using the lift lock **3**.



## CONTROL PANEL AND SAFETY DEVICES AT GROUND LEVEL

### ⚠ IMPORTANT ⚠

This machine is equipped with an integrated tilting sensor in the ground level control panel (➔ 1 - INSTRUCTIONS AND SAFETY INSTRUCTIONS: MACHINE MAINTENANCE INSTRUCTIONS).

Left and right are defined in OPERATING THE MACHINE: TRANSPORT/WORKING POSITION.

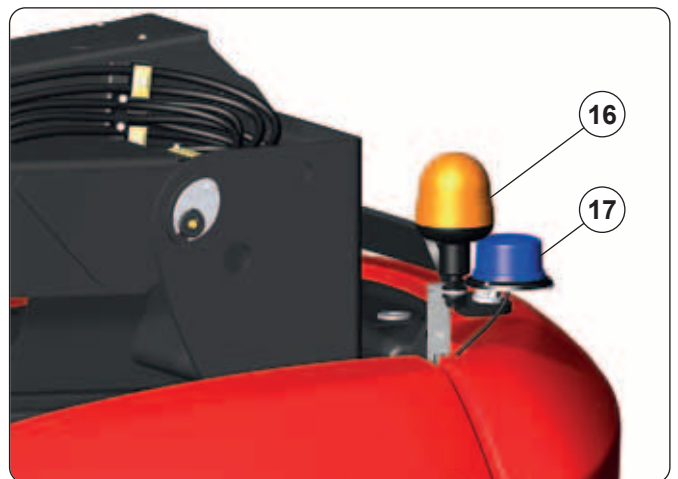
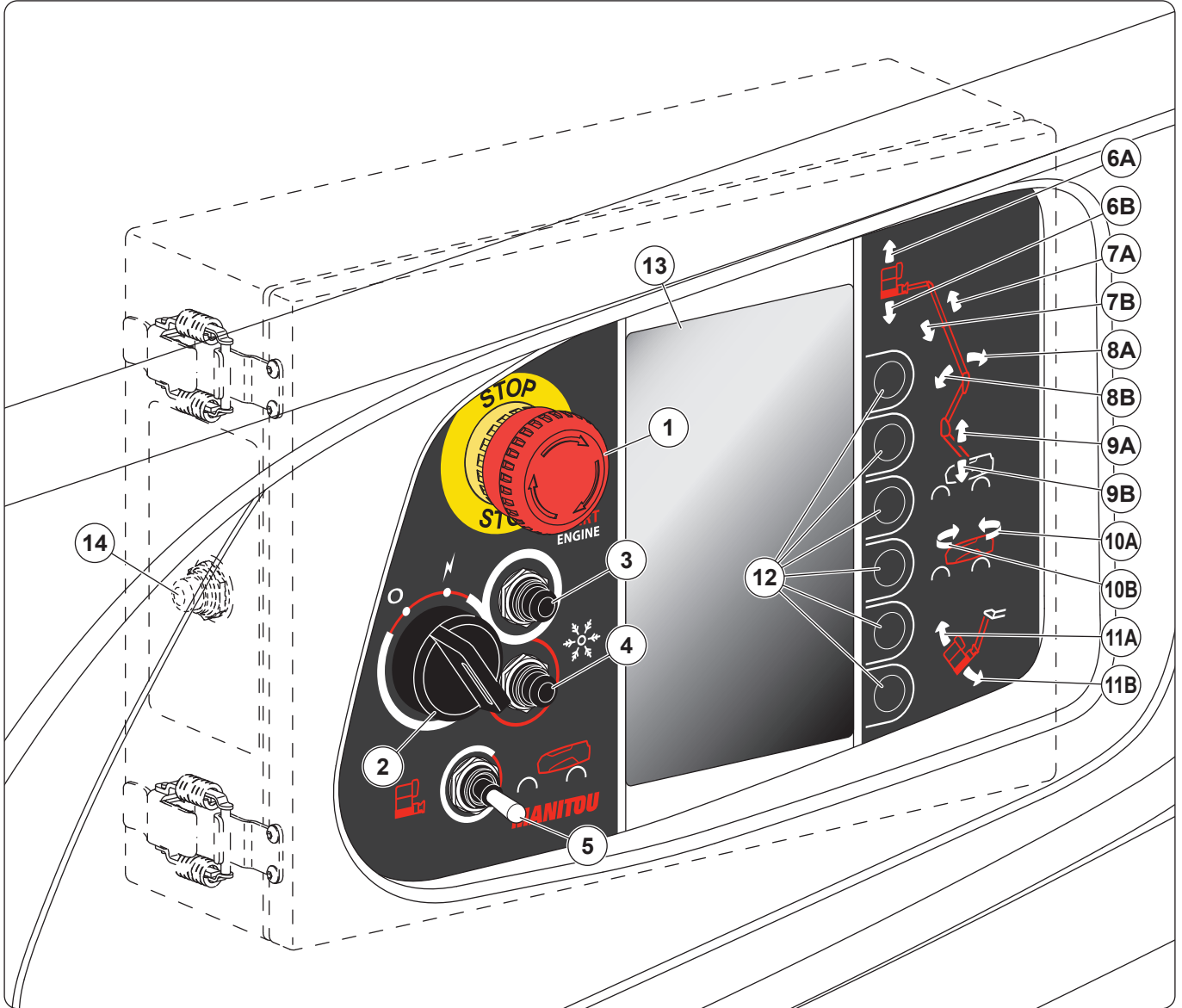

Note: the illustrations show a 160 ATJ.

1- EMERGENCY STOP BUTTON .....	2-38
2- KEY SWITCH .....	2-38
3- START BUTTON .....	2-38
4- START MODE BUTTON .....	2-38
5- ACTIVATION SWITCH .....	2-39
6- JIB ARM CONTROL BUTTONS .....	2-39
7- TELESCOPIC ARM CONTROL BUTTONS .....	2-39
8- MAIN ARM CONTROL BUTTONS .....	2-39
9- SECONDARY ARM CONTROL BUTTONS .....	2-40
10- TURNTABLE ROTATION CONTROL BUTTONS .....	2-40
11- PLATFORM/JIB ARM TILT CONTROL BUTTONS .....	2-40
12- NAVIGATION KEYS .....	2-40
13- GROUND LEVEL DISPLAY SCREEN .....	2-40
14- BACKUP PUMP BUTTON .....	2-41
15- HORN .....	2-41
16- ORANGE ROTATING BEACON LIGHT .....	2-41
17- FLASHING LIGHT SPS (OPTION) .....	2-41

## CONTROL PANEL AND SAFETY DEVICES IN THE PLATFORM

**⚠ IMPORTANT ⚠**

Front, rear, left and right are defined in **OPERATING THE MACHINE: TRANSPORT/WORKING POSITION.**

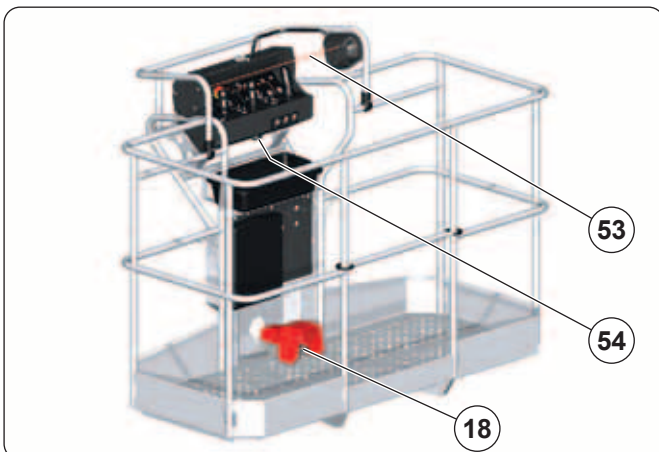
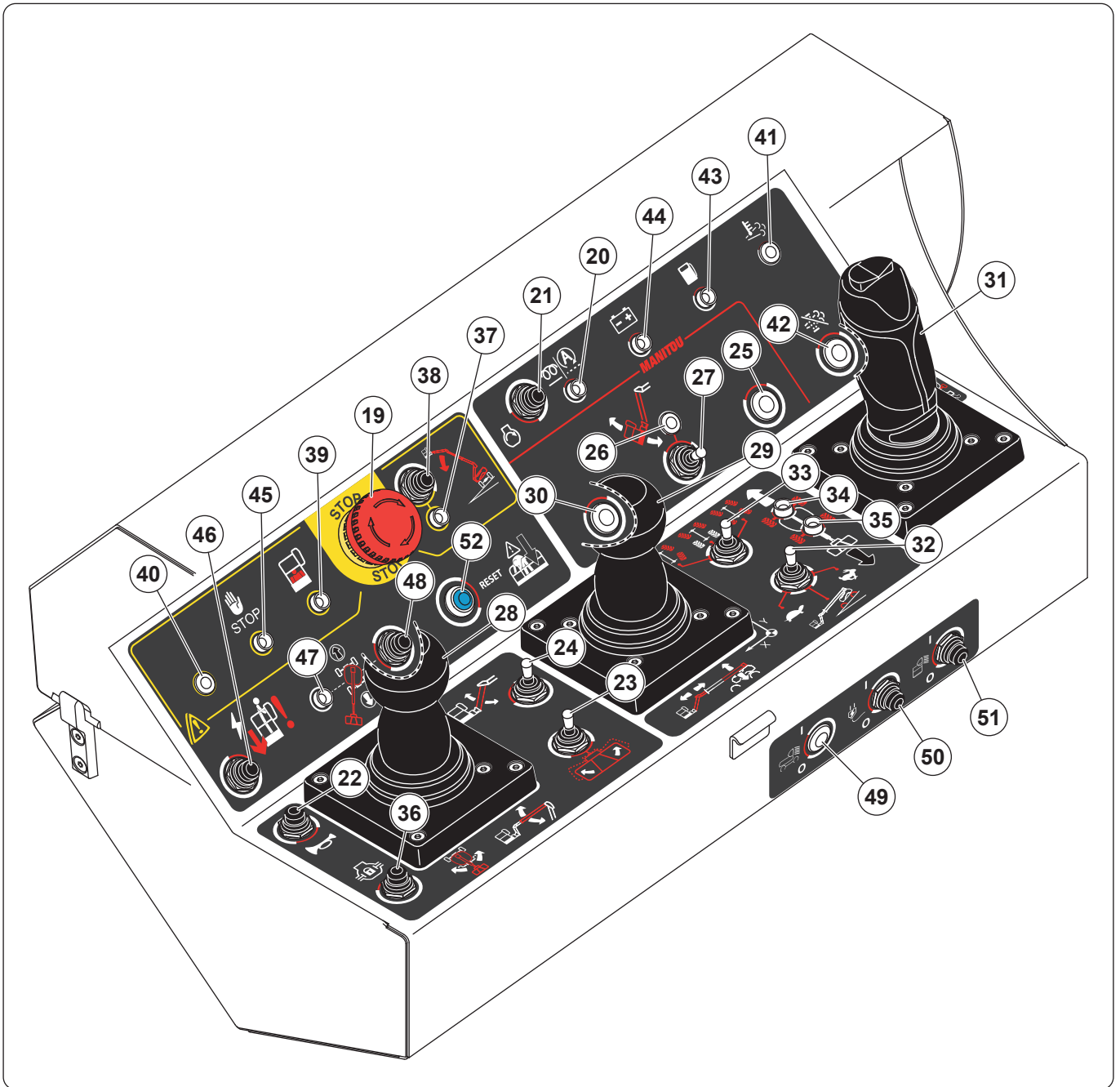

Note: the illustration shows a standard platform.

18- FOOT SWITCH .....	2-42
19- EMERGENCY STOP BUTTON .....	2-42
20- PREHEAT INDICATOR LIGHT .....	2-42
21- START BUTTON.....	2-42
22- HORN BUTTON .....	2-43
23- PLATFORM ROTATION SWITCH .....	2-43
24- JIB ARM SWITCH.....	2-43
25- NOT USED.....	2-43
26- NOT USED.....	2-43
27- PLATFORM/JIB ARM TILT SWITCH .....	2-44
28- MAIN ARM/TURNABLE ROTATION CONTROL HANDLE .....	2-44
29- SECONDARY ARM/TELESCOPE ARM CONTROL HANDLE .....	2-44
30- NOT USED.....	2-44
31- DRIVING/STEERING CONTROL HANDLE .....	2-45
32- DRIVING SPEED SWITCH .....	2-45
33- STEERING MODE SWITCH .....	2-46
34- FRONT WHEEL ALIGNMENT INDICATOR LIGHT .....	2-46
35- REAR WHEEL ALIGNMENT INDICATOR LIGHT .....	2-46
36- DIFFERENTIAL LOCK BUTTON .....	2-46
37- OSCILLATION TILT/LOCK INDICATOR LIGHT .....	2-47
38- USE ON SLOPE BUTTON .....	2-47
39- OVERLOAD INDICATOR LIGHT .....	2-48
40- NOT USED.....	2-48
41- NOT USED.....	2-48
42- NOT USED.....	2-48
43- FUEL INDICATOR LIGHT .....	2-49
44- BATTERY INDICATOR LIGHT .....	2-49
45- FAULT INDICATOR LIGHT .....	2-50
46- BACKUP PUMP BUTTON.....	2-50
47- TURNTABLE SLEWING INDICATOR LIGHT (OPTION).....	2-51
48- TURNTABLE SLEWING BUTTON (OPTION).....	2-51
49- NOT USED.....	2-51
50- ELECTRIC GENERATOR BUTTON (OPTION) .....	2-51
51- WORKLIGHT BUTTON (OPTION).....	2-51
52- RESET BUTTON SPS (OPTION) .....	2-51
53- SAFETY CABLE SPS (OPTION).....	2-51
54- AUDIBLE ALARM .....	2-52

## 1- EMERGENCY STOP BUTTON

### ⚠ IMPORTANT ⚠

*In all cases this control takes priority, even if the machine functions are activated from the platform control panel.  
Movements may stop suddenly if the emergency stop button is pressed.*

2 positions:

- Off (locked): press and hold the button.
- On (unlocked): pull the button or turn it clockwise and release.

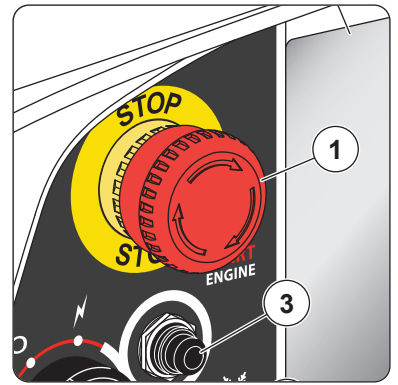

## 2- KEY SWITCH

2 positions:



Stop: the control system is turned off. The key can be removed.

Note: the battery cut-off (option) must be in the off position to start up the machine.



On: the control system is turned on. The key cannot be removed.

Note: the battery cut-off (option) must be in the on position and the 2 emergency stop buttons must be in the on position to start up the machine.

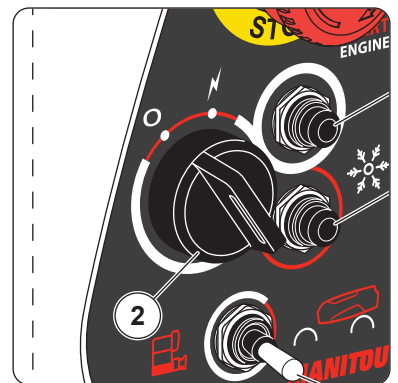

## 3- START BUTTON

### ⚠ IMPORTANT ⚠

*Do not keep the button pressed for more than 15 seconds.*

- Wait for the preheat cycle to finish.
- Press and hold down the button to start the diesel engine.
- Release it once the diesel engine has started.

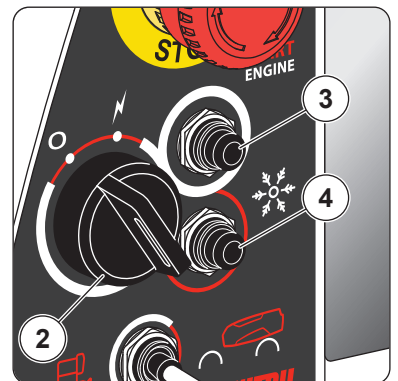

## 4- START MODE BUTTON

2 positions:

- Sun position if outside temperature above -10 °C:
  - Activated by default.
- Snow position if outside temperature below -10 °C:
  - Press the button and release.
  - Press and hold the start button to start the diesel engine: it runs at high speed.
  - Release it once the diesel engine has started.
  - Wait for between 30 and 60 seconds without using the machine's functions.
  - Press the button and release or use a machine function to switch to sun position: the diesel engine runs at idle speed.

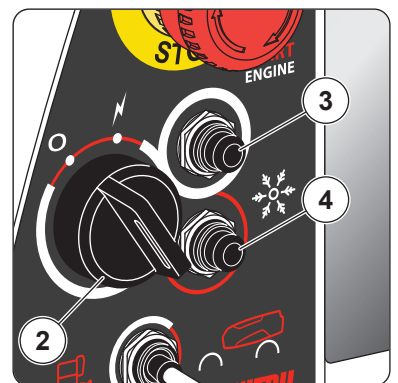

## 5- ACTIVATION SWITCH

2 positions:



Platform controls: the platform controls are activated when the switch is released.



Ground level controls: push and hold the switch to the right to activate the ground level controls.

Note: this operating mode is called the "dead man" function.

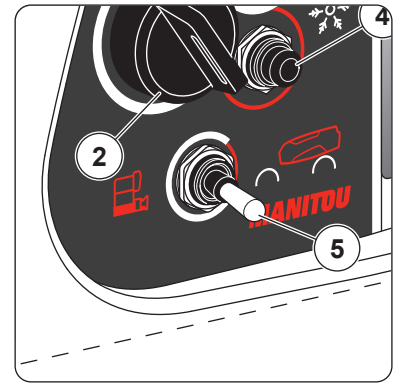

## 6- JIB ARM CONTROL BUTTONS

- Push and hold the activation switch to the right  (ground level controls position).

### RAISE THE JIB ARM

- Press and hold down the button **6A**. Release to stop.

### LOWER THE JIB ARM

- Press and hold down the button **6B**. Release to stop.

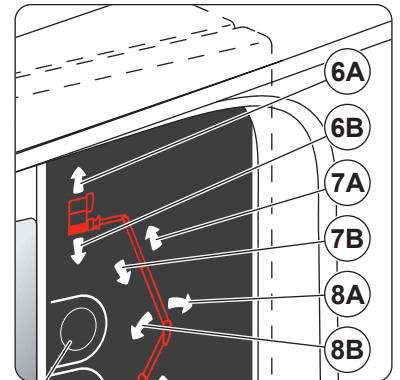

## 7- TELESCOPIC ARM CONTROL BUTTONS

- Push and hold the activation switch to the right  (ground level controls position).

### EXTEND THE TELESCOPIC ARM

- Press and hold down the button **7A**. Release to stop.

### RETRACT THE TELESCOPIC ARM

- Press and hold down the button **7B**. Release to stop.

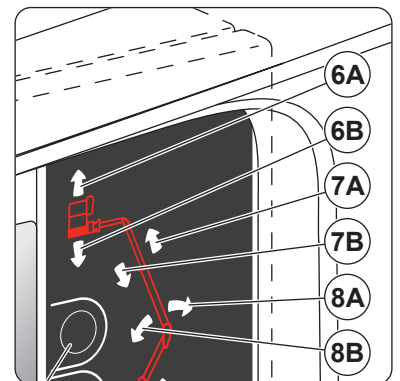

## 8- MAIN ARM CONTROL BUTTONS

- Push and hold the activation switch to the right  (ground level controls position).

### RAISE THE MAIN ARM

- Press and hold down the button **8A**. Release to stop.

### LOWER THE MAIN ARM

- Press and hold down the button **8B**. Release to stop.

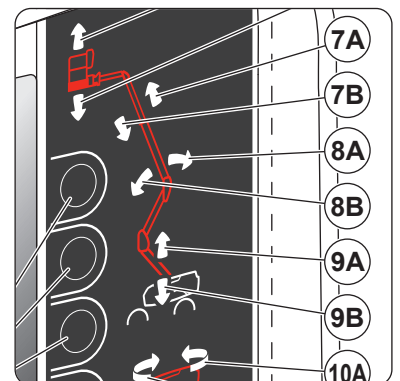

## 9- SECONDARY ARM CONTROL BUTTONS

- Push and hold the activation switch to the right  (ground level controls position).

### RAISE THE SECONDARY ARM

- Press and hold down the button . Release to stop.

### LOWER THE SECONDARY ARM

- Press and hold down the button . Release to stop.

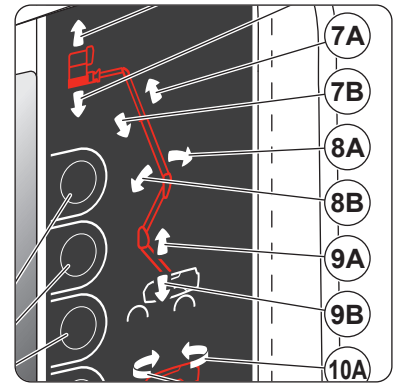

## 10- TURNTABLE ROTATION CONTROL BUTTONS

- Push and hold the activation switch to the right  (ground level controls position).

### TURN THE TURNTABLE TO THE RIGHT

- Press and hold down the button . Release to stop.

### TURN THE TURNTABLE TO THE LEFT

- Press and hold down the button . Release to stop.

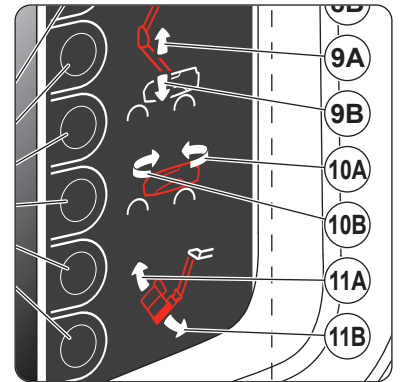

## 11- PLATFORM/JIB ARM TILT CONTROL BUTTONS

- Push and hold the activation switch to the right  (ground level controls position).

### TILT THE PLATFORM/JIB ARM UP

- Press and hold down the button . Release to stop.

### TILT THE PLATFORM/JIB ARM DOWN

- Press and hold down the button . Release to stop.

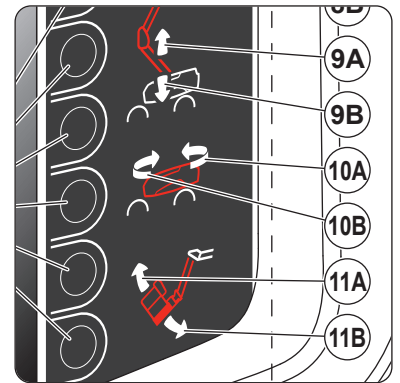

## 12- NAVIGATION KEYS

- ◀ GROUND LEVEL DISPLAY SCREEN.

## 13- GROUND LEVEL DISPLAY SCREEN

- ◀ GROUND LEVEL DISPLAY SCREEN.

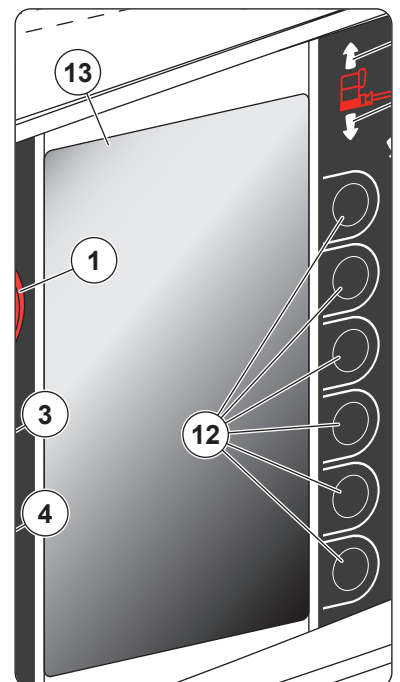

## 14- BACKUP PUMP BUTTON

☞ EMERGENCY CONTROLS.

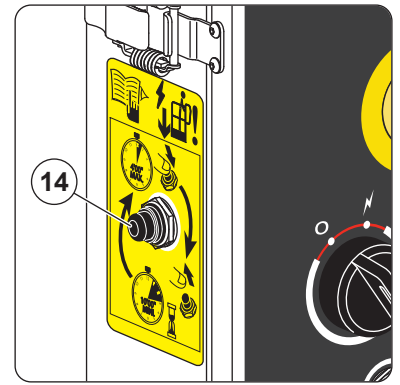

## 15- HORN

The horn sounds:

- When the horn button is pressed.
- Twice when the diesel engine has been started without activating the machine's functions for 10 seconds, ☞ GROUND LEVEL DISPLAY SCREEN: ALERT PAGE AND FAULT PAGE.

All movements alarm option: it sounds intermittently when the machine functions are activated and when driving/steering the machine.

Driving/steering alarm option: it sounds intermittently when driving/steering the machine.

Secondary protection system option SPS, ☞ OPTIONS: SECONDARY PROTECTION SYSTEM SPS.

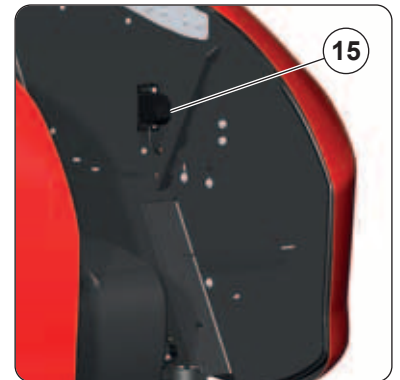

## 16- ORANGE ROTATING BEACON LIGHT

Permanent orange rotating beacon light option deactivated: it comes on when the machine functions are activated and when driving/steering the machine.

Permanent orange rotating beacon light activated: it comes on when the machine is powered up.

Note: there is a specific operating mode with the diesel engine automatic stop system "stop and go", ☞ OPERATING THE MACHINE: DIESEL ENGINE AUTOMATIC STOP SYSTEM "STOP AND GO".

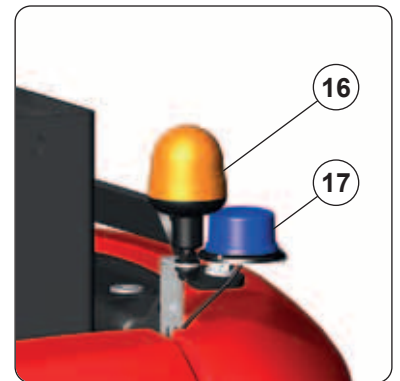

## 17- FLASHING LIGHT SPS (OPTION)

☞ OPTIONS: SECONDARY PROTECTION SYSTEM SPS.

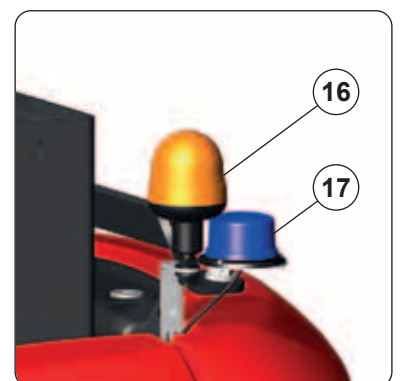

## 18- FOOT SWITCH

### ⚠ IMPORTANT ⚠

*Do not press the foot switch when starting the diesel engine.*

Note: the illustration shows a standard platform.

- Press and hold down the foot switch to activate the machine functions from the platform control panel.

Note: this operating mode is called the "dead man" function.

Note: there is a specific operating mode with the diesel engine automatic stop system "stop and go", <img alt="stop and go symbol" data-bbox="245 185 255 195"/> OPERATING THE MACHINE: DIESEL ENGINE AUTOMATIC STOP SYSTEM "STOP AND GO".

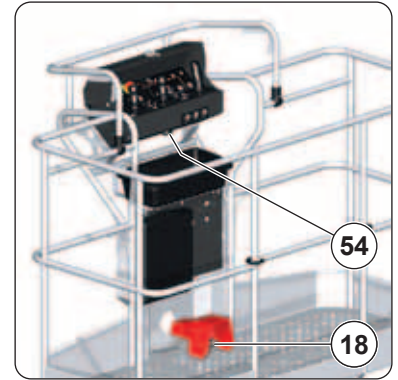

## 19- EMERGENCY STOP BUTTON

### ⚠ IMPORTANT ⚠

*In all cases, this control takes priority, except when the machine functions are activated from the ground level control panel.*

*Movements may stop suddenly if the emergency stop button is pressed.*

2 positions:

- Off (locked): press and hold the button.
- On (unlocked): pull the button or turn it clockwise and release.

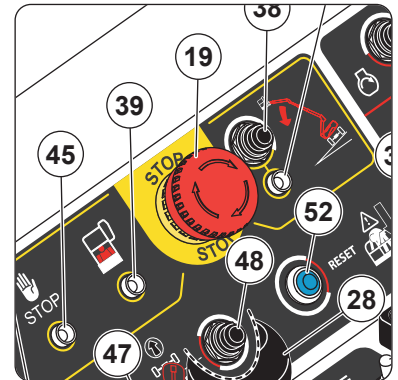

## 20- PREHEAT INDICATOR LIGHT

The indicator light is lit during the diesel engine preheat cycle.

It switches off when the preheat cycle is completed.

It flashes when the diesel engine is stopped by the diesel engine automatic stop system "stop and go", <img alt="stop and go symbol" data-bbox="245 545 255 555"/> OPERATING THE MACHINE. DIESEL ENGINE AUTOMATIC STOP SYSTEM "STOP AND GO".

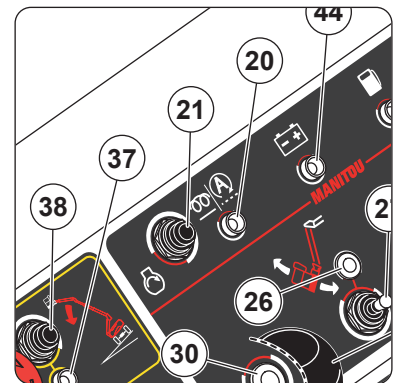

## 21- START BUTTON

### ⚠ IMPORTANT ⚠

*Do not keep the button pressed for more than 15 seconds.*

- Wait for the preheat cycle to finish.
- Press and hold down the button to start the diesel engine.
- Release it once the diesel engine has started.

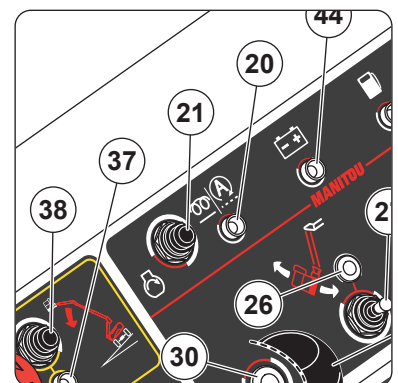

## 22- HORN BUTTON

- Press and hold down the button to sound the horn. Release to stop.

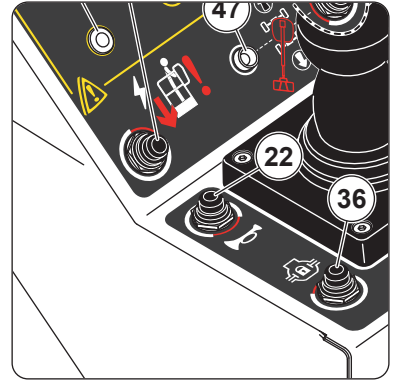

## 23- PLATFORM ROTATION SWITCH

- Press and hold down the foot switch.

### TURN THE PLATFORM TO THE LEFT

- Push and hold the switch to the left. Release to stop.

### TURN THE PLATFORM TO THE RIGHT

- Push and hold the switch to the right. Release to stop.

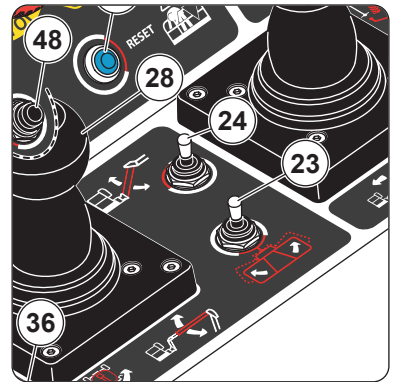

## 24- JIB ARM SWITCH

- Press and hold down the foot switch.

### RAISE THE JIB ARM

- Push and hold the switch forward. Release to stop.

### LOWER THE JIB ARM

- Pull and hold the switch backward. Release to stop.

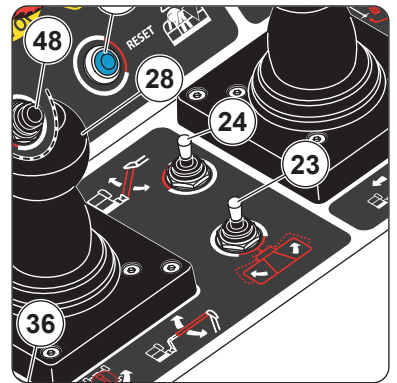

## 25- NOT USED

## 26- NOT USED

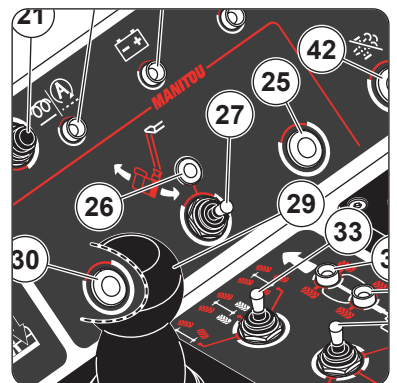

## **27- PLATFORM/JIB ARM TILT SWITCH**

Note: the functions are locked when the machine is in working position,  OPERATING THE MACHINE: TRANSPORT/WORKING POSITION.

- Press and hold down the foot switch.

### **TILT THE PLATFORM/JIB ARM UP**

- Push and hold the switch upward. Release to stop.

### **TILT THE PLATFORM/JIB ARM DOWN**

- Push and hold the switch downward. Release to stop.

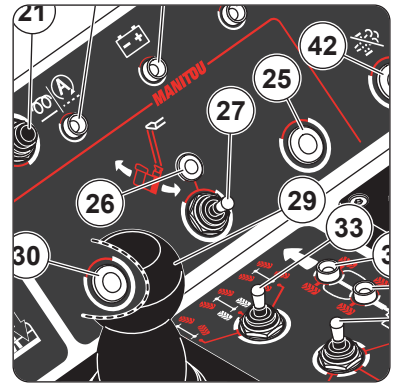

## **28- MAIN ARM/TURNTABLE ROTATION CONTROL HANDLE**

Note: the proportional control handle must be operated smoothly, without jerking.

- Press and hold down the foot switch.

### **RAISE THE MAIN ARM**

- Push and hold the control handle forward. Release to stop.

### **LOWER THE MAIN ARM**

- Pull and hold the control handle back. Release to stop.

### **TURN THE TURNTABLE TO THE LEFT**

- Push and hold the control handle to the left. Release to stop.

### **TURN THE TURNTABLE TO THE RIGHT**

- Push and hold the control handle to the right. Release to stop.

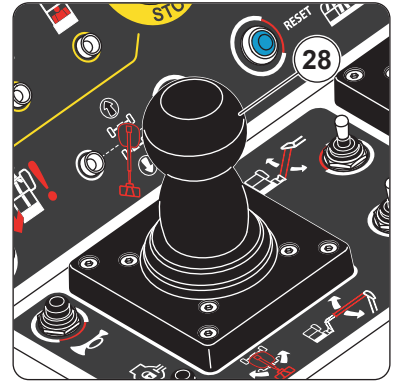

## **29- SECONDARY ARM/TELESCOPE ARM CONTROL HANDLE**

Note: the proportional control handle must be operated smoothly, without jerking.

- Press and hold down the foot switch.

### **RAISE THE SECONDARY ARM**

- Push and hold the control handle forward. Release to stop.

### **LOWER THE SECONDARY ARM**

- Pull and hold the control handle back. Release to stop.

### **EXTEND THE TELESCOPIC ARM**

- Push and hold the control handle to the left. Release to stop.

### **RETRACT THE TELESCOPIC ARM**

- Push and hold the control handle to the right. Release to stop.

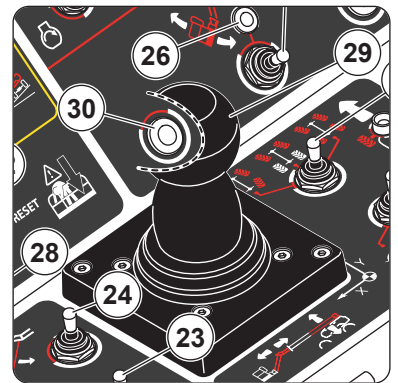

## **30- NOT USED**

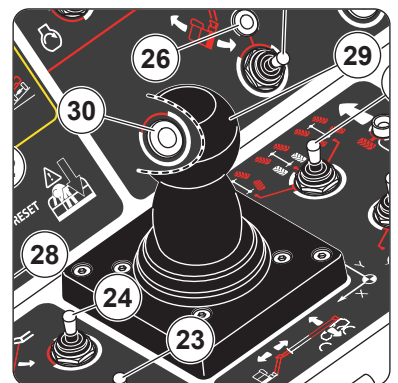

### 31- DRIVING/STEERING CONTROL HANDLE

**⚠ IMPORTANT ⚠**

*Always refer to the colors of the arrows on the chassis and on the control panel in the platform before driving/steering the machine.*

Note: the proportional control handle must be operated smoothly, without jerking.

- Press and hold down the foot switch.
- Press and hold down trigger **A**.

**DRIVE FORWARD**

- Push and hold the control handle forward. Release to brake.

**DRIVE BACKWARD**

- Pull and hold the control handle back. Release to brake.

**BRAKE**

- Release the control handle in neutral position to action the brakes.

Note: the brakes are also actioned when the foot switch and/or the trigger are released.

**STEER TO THE LEFT**

- Press and hold down button **B**. Release to stop.

**STEER TO THE RIGHT**

- Press and hold down button **C**. Release to stop.

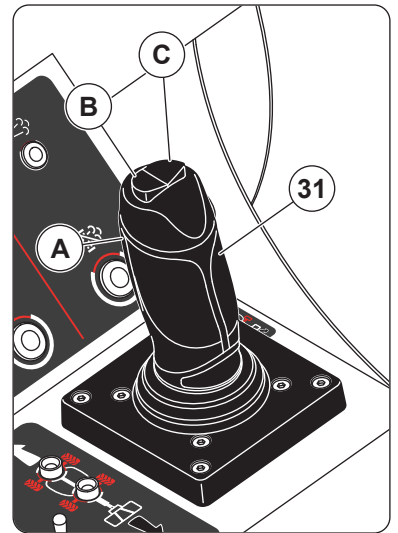
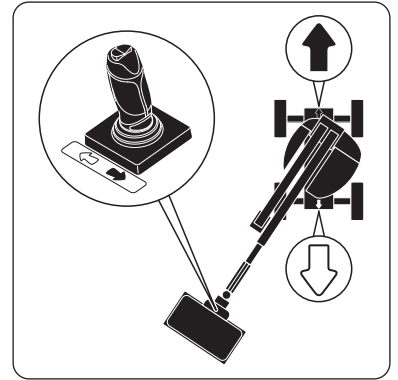

### 32- DRIVING SPEED SWITCH

**⚠ IMPORTANT ⚠**

*Always brake the machine before selecting the driving speed.*

3 positions:

 Tortoise speed for driving the machine at slow speed.

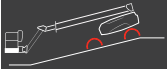
 Ramp speed for driving the machine at slow speed with full power.

 Hare speed for driving the machine at high speed.

Note: depending on conditions, restrictions may apply to the speed activated,  
 ◀ OPERATING THE MACHINE: TRANSPORT/WORKING POSITION.

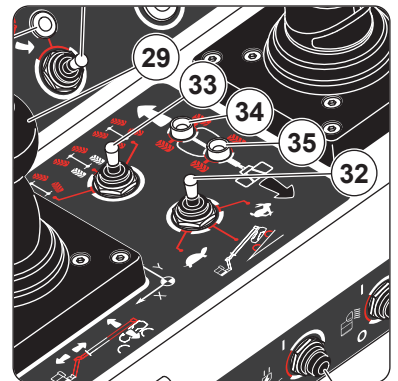

### 33- STEERING MODE SWITCH

**⚠ IMPORTANT ⚠**

*Always brake the machine before changing the steering mode.*

*The front and rear wheels must be correctly aligned with the machine axis before changing the steering mode,*

*◀ FRONT WHEEL ALIGNMENT INDICATOR LIGHT and ▶ REAR WHEEL ALIGNMENT INDICATOR LIGHT.*

*If the wheels are not correctly aligned:*

- Select the 4 wheel steer mode and align the rear wheels.*
- Select the 2 wheel steer mode and align the front wheels.*

3 positions:



4 wheel steer mode: front and rear steering wheels in opposite directions.



2 wheel steer mode: front steering wheels.



Crab mode: front and rear steering wheels in the same direction.

Note: depending on conditions, restrictions may apply to the speed activated,

◀ OPERATING THE MACHINE: TRANSPORT/WORKING POSITION.

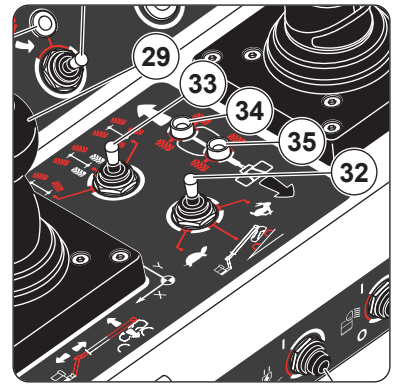

### 34- FRONT WHEEL ALIGNMENT INDICATOR LIGHT

The indicator light comes on when the front wheels are correctly aligned with the machine axis.

### 35- REAR WHEEL ALIGNMENT INDICATOR LIGHT

The indicator light comes on when the rear wheels are correctly aligned with the machine axis.

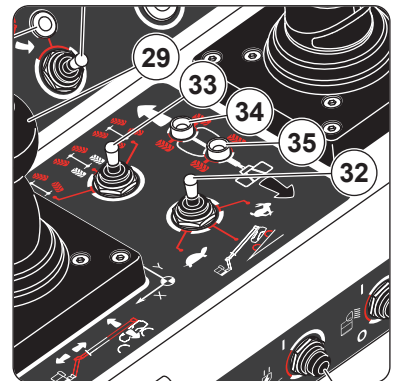

### 36- DIFFERENTIAL LOCK BUTTON

**⚠ IMPORTANT ⚠**

*Always brake the machine before locking the differential.*

*It is recommended to align the wheels with the machine axis before locking and unlocking the differential.*

#### LOCK THE DIFFERENTIAL

- Drive the machine, then press and hold down the button.

#### UNLOCK THE DIFFERENTIAL

- Release the button, then brake the machine.

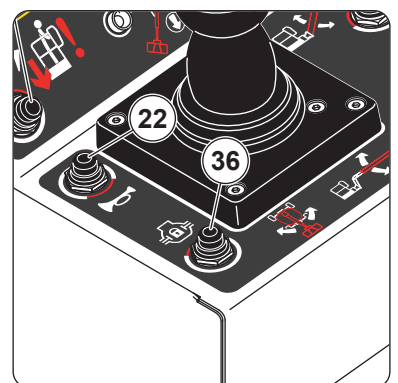

### 37- OSCILLATION TILT/LOCK INDICATOR LIGHT

#### TILT WARNING

It occurs when the tilt of the chassis is greater than the maximum authorized value:

- The indicator light flashes (on = 0.6 seconds, off = 0.4 seconds).
- The audible alarm sounds intermittently (on = 1 second, off = 1 second).
- Some machine functions are locked, <img alt="lock symbol" data-bbox="105 135 125 150"/> OPERATING THE MACHINE: LOCKED FUNCTIONS.

Stop the tilt warning and unlock the machine functions (machine in transport position):

- Move the machine to a level surface.

Stop the tilt warning and unlock the machine functions (machine in work position):

- 1- Fully retract the telescopic arm.
- 2- Fully lower the main arm.
- 3- Fully lower the secondary arm.
- 4- Move the machine to a level surface.

#### OSCILLATION LOCK FAULT

It occurs when an oscillating axle locking fault occurs (machine in working position):

- The indicator light flashes (on = 0.4 seconds, off = 0.2 seconds).
- The fault indicator light flashes, <img alt="lock symbol" data-bbox="105 330 125 345"/> FAULT INDICATOR LIGHT.
- The audible alarm sounds intermittently (on = 0.4 second, off = 0.4 second).
- Some machine functions are locked, <img alt="lock symbol" data-bbox="105 355 125 370"/> OPERATING THE MACHINE: LOCKED FUNCTIONS.

React in the event of an oscillation lock fault:

- 1- Fully retract the telescopic arm.
- 2- Fully lower the main arm.
- 3- Fully lower the secondary arm.
- 4- Fully lower the jib arm.
- 5- Move the machine to a level surface.
- 6- Stop using the machine and refer to the maintenance personnel.

### 38- USE ON SLOPE BUTTON

#### IMPORTANT

*The machine could tip over when this function is used. Use with extreme caution.*

- Press the button and hold it down to activate the locked functions (except driving forward and backward) when the tilt alarm is activated. <img alt="lock symbol" data-bbox="105 575 125 590"/> OSCILLATION TILT/LOCK INDICATOR LIGHT.

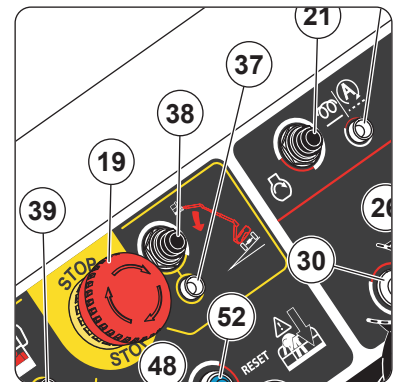
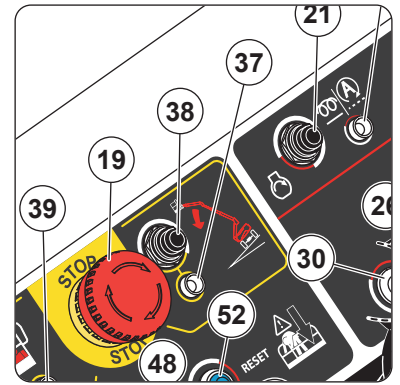

### 39- OVERLOAD INDICATOR LIGHT

---

#### OVERLOAD WARNING

It occurs when the platform load has reached maximum load capacity:

- The indicator light flashes.
- The audible alarm sounds continuously.
- All the machine's functions are locked,  OPERATING THE MACHINE: LOCKED FUNCTIONS.

Stop the overload warning and unlock the machine functions:

- Remove the excess load from the platform.

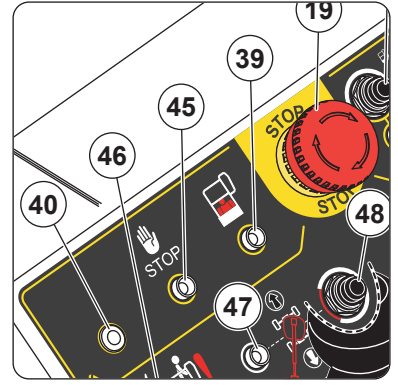

### 40- NOT USED

---

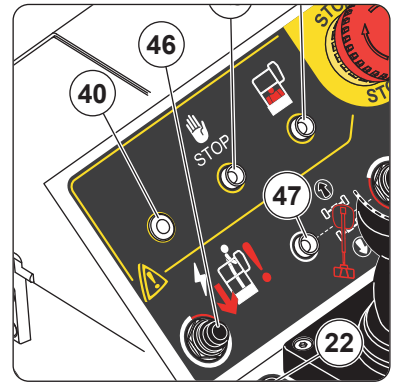

### 41- NOT USED

---

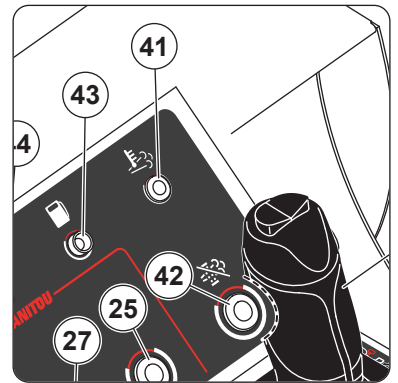

### 42- NOT USED

---

### 43- FUEL INDICATOR LIGHT

#### LOW FUEL LEVEL FAULT

It occurs when the fuel level is low.

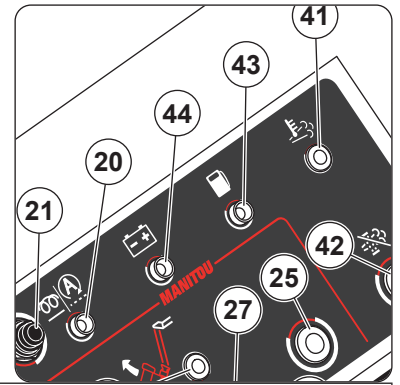

	FUEL ALARM LIGHT	AUDIBLE ALARM
Level 1	On = 0.8 seconds Off = 0.4 seconds	3 beeps (ON = 0.6 seconds, OFF = 0.4 seconds) repeated every 10 minutes
Level 2	On = 0.4 seconds Off = 0.4 seconds	3 beeps (ON = 0.4 seconds, OFF = 0.4 seconds) repeated every minute
Level 3 (1)	On = 0.3 seconds Off = 0.2 seconds	3 beeps (ON = 0.4 seconds, OFF = 0.4 seconds) repeated every 10 seconds

(1) The fault indicator light flashes at the same time.

(1) It is no longer possible to raise the main arm, raise the secondary arm, extend the telescopic arm, raise the jib arm, tilt the platform/jib arm upward or downward, turn the turntable and turn the platform for more than 2 seconds at a time.

### 44- BATTERY INDICATOR LIGHT

#### LOW BATTERY FAULT

It occurs when the diesel engine is automatically stopped by the diesel engine automatic stop system "stop and go" and the battery voltage is low:

- The indicator light comes on.
- The audible alarm sounds intermittently.

React in the event of a low battery fault:

- It is recommended to restart the diesel engine.

Note: ⚠ OPERATING THE MACHINE: DIESEL ENGINE AUTOMATIC STOP SYSTEM "STOP AND GO".

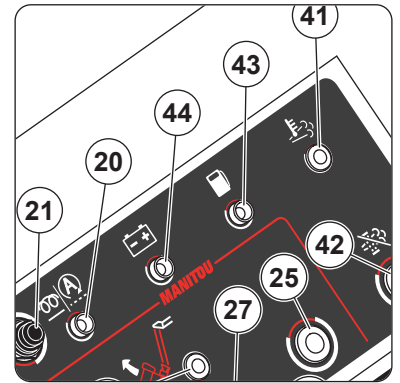

## 45- FAULT INDICATOR LIGHT

### ⚠ IMPORTANT ⚠

Refer to the maintenance personnel if there is a fault.

The fault indicator light flashes when a fault occurs:

- Minor fault: on = 0.6 seconds, off = 0.4 seconds.
- Major fault: on = 0.3 seconds, off = 0.2 seconds.

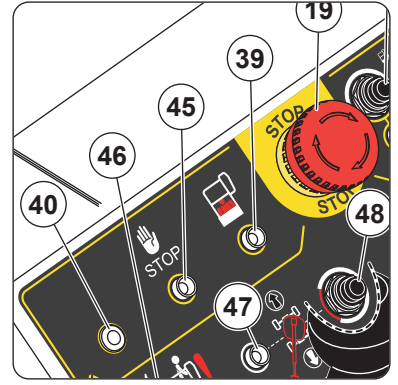

MINOR FAULTS	AUDIBLE ALARM	
The foot switch or the activation switch is blocked	1 beep	Stop using the machine.
The driving/steering control handle trigger is locked		
The safety cable SPS or the reset button SPS is blocked (option: secondary protection system SPS)	3 beeps repeated every 8 seconds	
Other minor faults	Stop	

MAJOR FAULTS	AUDIBLE ALARM	
CAN Communication	Stop	All the functions of the machine are locked.
Low diesel engine oil pressure	Sounds intermittently	Stop the diesel engine immediately
High coolant temperature.		Note: the diesel engine stops after 90 seconds
Inconsistent tilt sensor calibration.	Stop	The simultaneous functions are locked. The movement speeds are reduced.
Diesel engine overspeed	Stop	The diesel engine stops after 2 seconds.
Hydrostatic pump	Stop	The driving functions are locked.
Proportional distributor	Sounds intermittently	Stop using the machine.
Overload sensor inconsistency		
Locking of the oscillating axle (1)		
Diesel engine oil pressure sensor.	Stop	
Fuel level very low (level 3)	◀ FUEL INDICATOR LIGHT	

(1) The oscillation tilt/lock indicator light flashes at the same time.

## 46- BACKUP PUMP BUTTON

◀ EMERGENCY CONTROLS.

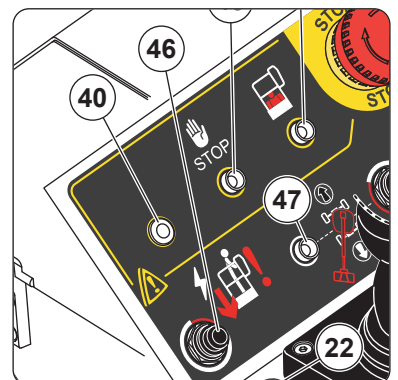

647909 (A112020)  
160 ATJ 4RD ST5 S2 / 160 ATJ RC 4RD ST5 S2  
180 ATJ 4RD ST5 S2 / 180 ATJ RC 4RD ST5 S2

### **47- TURNTABLE SLEWING INDICATOR LIGHT (OPTION)**

< OPTIONS: TURNTABLE SLEWING ALARM.

### **48- TURNTABLE SLEWING BUTTON (OPTION)**

< OPTIONS: TURNTABLE SLEWING ALARM.

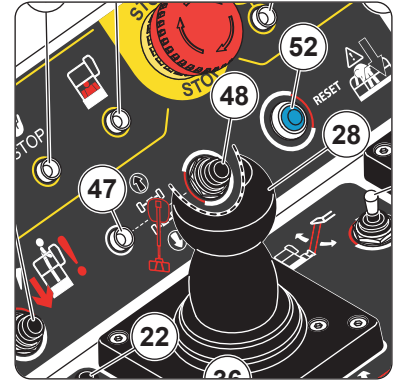

### **49- NOT USED**

### **50- ELECTRIC GENERATOR BUTTON (OPTION)**

< OPTIONS: ELECTRIC GENERATOR.

### **51- WORKLIGHT BUTTON (OPTION)**

< OPTIONS: WORKLIGHT IN THE PLATFORM

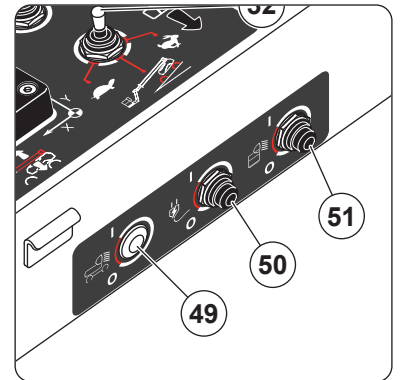

### **52- RESET BUTTON SPS (OPTION)**

< OPTIONS: SECONDARY PROTECTION SYSTEM SPS.

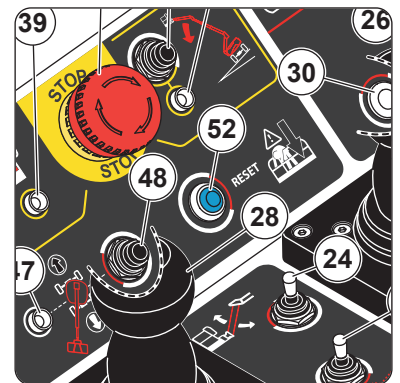

### **53- SAFETY CABLE SPS (OPTION)**

Note: the illustration shows a standard platform.

< OPTIONS: SECONDARY PROTECTION SYSTEM SPS.



## 54- AUDIBLE ALARM

Note: the illustration shows a standard platform.

The audible alarm sounds:

- Once after the machine has been powered up.
- Twice when the machine's functions cannot be activated simultaneously, <math>\triangleleft</math> OPERATING THE MACHINE.

### TILT WARNING

- It sounds intermittently when the tilt of the chassis is greater than the maximum authorized value, <math>\triangleleft</math> OSCILLATION TILT/LOCK INDICATOR LIGHT.

### OSCILLATION LOCK FAULT

- Intermittently when an oscillating axle locking fault occurs, <math>\triangleleft</math> OSCILLATION TILT/LOCK INDICATOR LIGHT.

### OVERLOAD WARNING

- It sounds continuously when the platform load has reached maximum load capacity, <math>\triangleleft</math> OVERLOAD INDICATOR LIGHT.

### LOW FUEL LEVEL FAULT

- It sounds when the fuel level is low, <math>\triangleleft</math> FUEL INDICATOR LIGHT.

### LOW BATTERY FAULT

- It sounds intermittently when the battery voltage is low, <math>\triangleleft</math> BATTERY INDICATOR LIGHT.

### OTHER FAULTS

- It sounds when a minor or major fault occurs, <math>\triangleleft</math> FAULT INDICATOR LIGHT.

### TURNTABLE SLEWING ALARM (OPTION)

- It sounds twice when you try to drive, <math>\triangleleft</math> OPTION: TURNTABLE SLEWING ALARM.

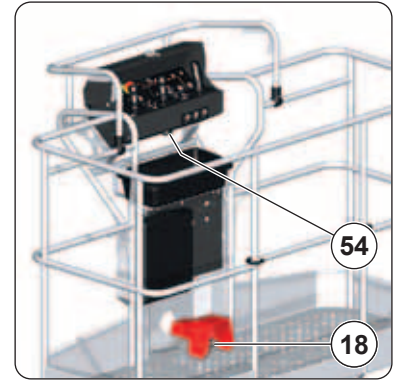

## GROUND LEVEL DISPLAY SCREEN

### POWER-UP CYCLE

The following pages are displayed in turn when the machine is turned on.

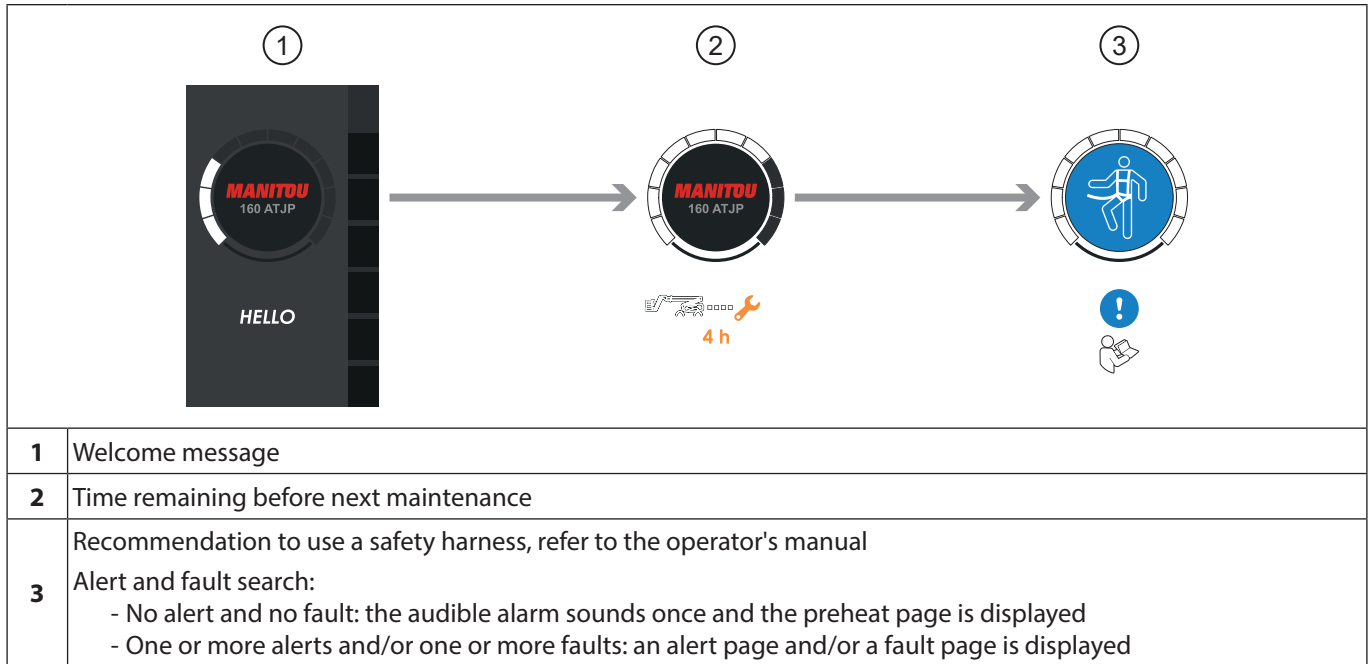

### DISPLAY ZONES

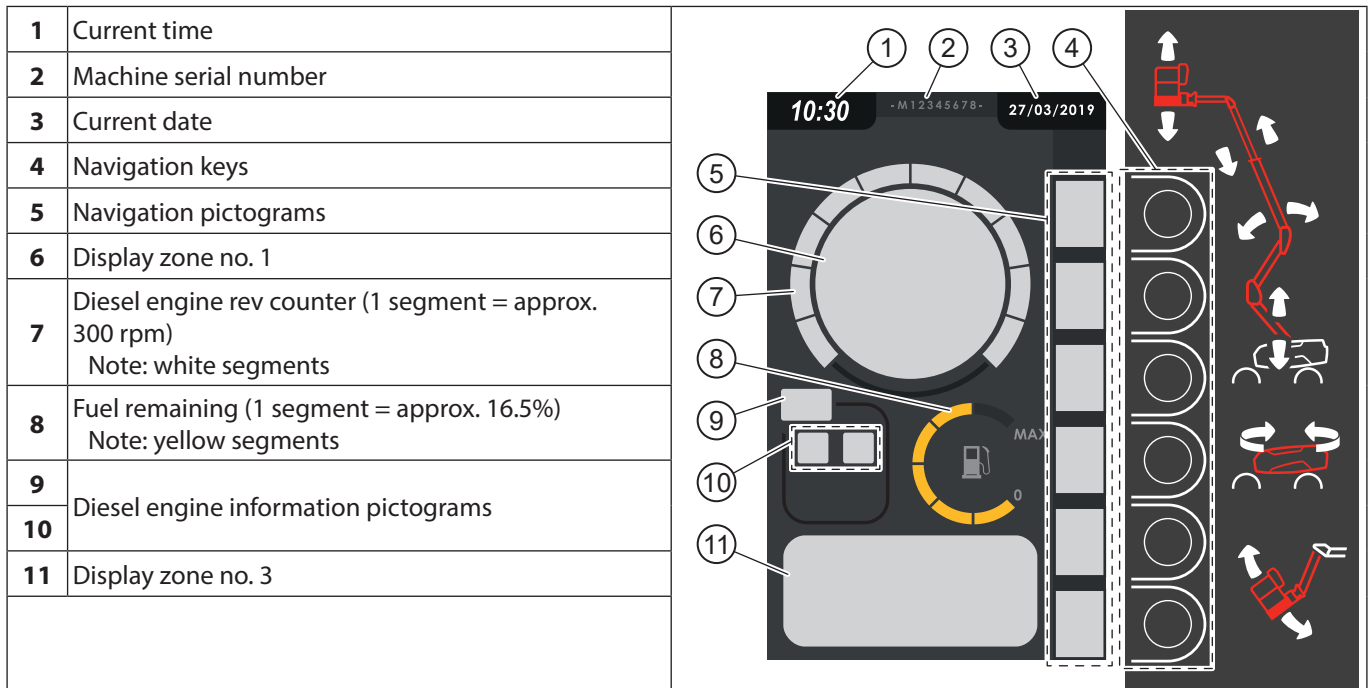

























## NAVIGATION PICTOGRAMS

**⚠ IMPORTANT ⚠**







Consult maintenance personnel when the "maintenance warning" pictogram  (orange background) is displayed.

The navigation keys  activate the controls relating to the navigation pictograms  displayed:

5		Access to menus
		Return to the previous menu
		Validation of the selection
		Update display
		Upward navigation in the menu
		Downward navigation in the menu
		Move left on the page
		Move right on the page
		Move up on the page
		Move down on the page
		Navigation in the menu (pages) activated
		Navigation in the menu (lines) activated
		Write mode

5		Increment
		Decrement
		Validate change
		Cancellation of the modification
		Day/night screen display change
		Quick access to maintenance menu (black background)
		Maintenance warning (orange background), quick access to the maintenance menu
		Quick access to the alert and fault list
		View the fault type
		Filtering of alerts, faults and events
		Deletion of an alert, fault or event display
		Restore factory settings



## DIESEL ENGINE INFORMATION PICTOGRAMS

9		No diesel engine fault
		Minor diesel engine fault, <img alt="left arrow" data-bbox="215 515 235 535"/> ALERT PAGE AND FAULT PAGE
		Major diesel engine fault, <img alt="left arrow" data-bbox="215 535 235 555"/> ALERT PAGE AND FAULT PAGE
10		Diesel engine stopped or stopping
		Diesel engine starting
		Diesel engine automatic stop system "stop and go" deactivated
		Diesel engine automatic stop system "stop and go" activated

**PREHEAT PAGE**

The following information is displayed when:

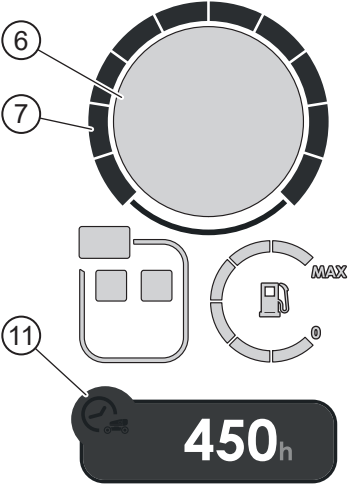
- The diesel engine has not been started.
- There is no alarm.
- There is no fault.

<b>6</b>	Preheat cycle in progress Note: pictogram and orange time indicator		
	Preheat cycle finished: "ok ready to start" is displayed Note: green background		
<b>7</b>	Diesel engine stopped Note: gray segments		
<b>11</b>	Total running time in hours		

**WORK PAGE**

The following information is displayed when:

- The diesel engine has been started.
- There is no alarm.
- There is no fault.

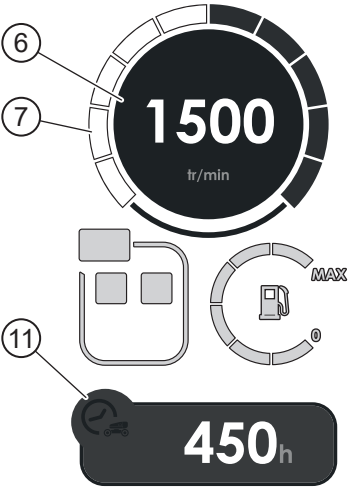
<b>6</b>	Diesel engine rev counter in rpm	
<b>7</b>	Diesel engine rev counter (1 segment = approx. 300 rpm) Note: white segments	
<b>11</b>	Total running time in hours	



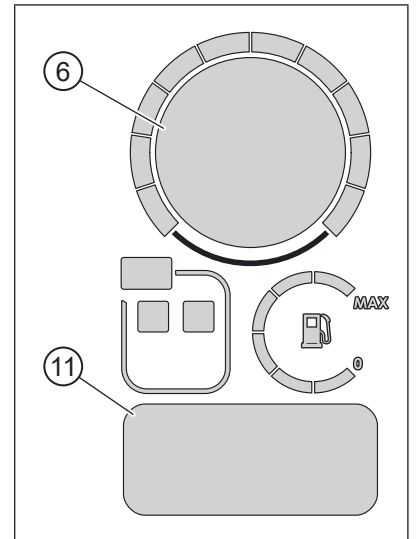

**ALERT PAGE AND FAULT PAGE**

The following information is displayed when:



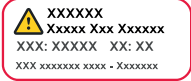

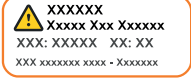
- One or more alerts occur and/or one or more faults occur.

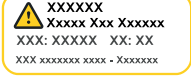
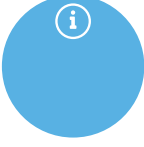
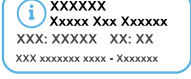

**ALERTS**

Single alert display		Alert description display		Type	Description
6	 Note: red background with pictogram depending on the alert	11	 Note: red box	Danger	Indicates a hazardous situation which, if not avoided, will result in death or serious injury
6	 Note: orange background with pictogram depending on the alert	11	 Note: orange box	Warning	Indicates a hazardous situation which, if not avoided, may result in death or serious injury
6	 Note: yellow background with pictogram depending on the alert	11	 Note: yellow box	Important	Indicates a hazardous situation which, if not avoided, may result in minor or moderate injury
6	 Note: blue background with pictogram depending on the alert	11	 Note: blue box	Information	Indicates normal operation of the machine or a procedure to be followed that presents no risk of bodily injury

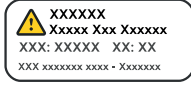
**FAULTS**

Multiple faults display		Single fault display		Fault description display		Type	Description	
6		6		11		Major diesel engine fault	Indicates a situation that, if not avoided, will result in damage to the machine but that does not pose any risk of bodily injury	
			Note: gray background with engine pictogram		Note: gray box	Major machine fault	Indicates a situation that, if not avoided, will result in damage to the machine but that does not pose any risk of bodily injury	
					Note: gray background with pictogram depending on the fault	Note: gray box	Minor diesel engine fault	Indicates a situation that, if not avoided, may result in damage to the machine but that does not pose any risk of bodily injury
					Note: gray background with engine pictogram	Note: gray box	Minor machine fault	Indicates a situation that, if not avoided, may result in damage to the machine but that does not pose any risk of bodily injury

## OPERATING THE MACHINE

### ⚠ IMPORTANT ⚠

The 1 - INSTRUCTIONS AND SAFETY INSTRUCTIONS part must be read and understood before using the machine.

### TRANSPORT/WORKING POSITION

#### TRANSPORT POSITION

Note: the illustration shows a 160 ATJ with a standard platform.

The machine is in transport position when:

- The main arm is completely lowered.
- The secondary arm is completely lowered.
- The telescopic arm is completely retracted.

Note: the jib arm may or may not be raised. The turntable and the platform may or may not be turned.

The turntable and the platform are in neutral position when the main arm and the platform are parallel to the machine's chassis with the platform between the 2 rear wheels.

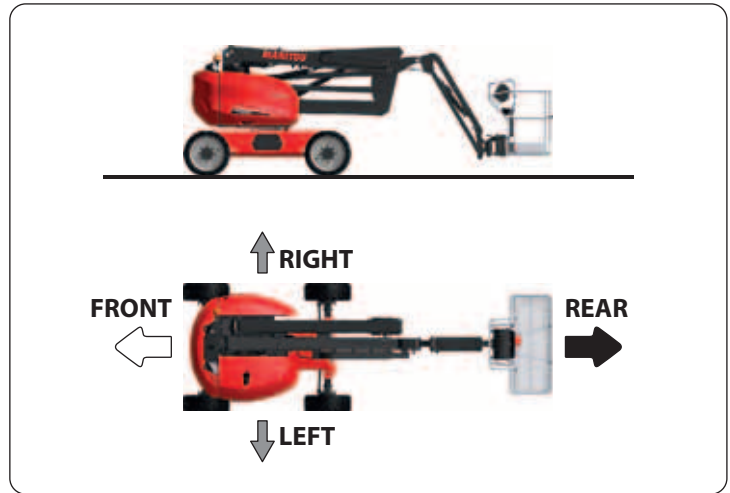

Front, rear, left and right are defined as follows:

- The machine is in transport position.
- The turntable and the platform are in neutral position.
- The operator is in the platform facing the direction of the front wheels.

The tortoise and hare speeds are only active in transport position.

	Tortoise speed selected	Ramp speed selected	Hare speed selected
Drive forward	Tortoise speed activated	Ramp speed activated	Hare speed activated*
Drive backward	Tortoise speed activated	Ramp speed activated	Ramp speed activated

\*: ramp speed is automatically activated in 4 wheel steer mode.

It is recommended that the turntable and platform are put in neutral position to drive the machine at hare speed.

When driving the machine over a long distance, it is recommended to:

- Place the machine in transport position.
- Put the turntable and platform in neutral position.
- Raise the jib arm slightly for better visibility.
- Drive the machine forward.

#### WORKING POSITION

### ⚠ IMPORTANT ⚠

*Traveling over rough terrain, on unstable ground, on slopes that are steeper than the maximum authorized chassis tilt (< SPECIFICATIONS) or in any other conditions likely to cause the machine to tip up or become destabilized is prohibited.*

The machine is in working transport position when:

- The main arm is not completely lowered.
- The secondary arm is not completely lowered.
- The telescopic arm is not completely retracted.

Note: the jib arm may or may not be raised. The turntable and the platform may or may not be turned.

The working speed is automatically activated when the machine is in working position.

## OPERATION FROM THE GROUND LEVEL CONTROL PANEL

### ⚠ IMPORTANT ⚠

◀ **CONTROL PANEL AND SAFETY DEVICES ON THE GROUND** for detailed information about the ground controls.

#### SWITCH ON THE MACHINE

- Ensure that the emergency stop buttons on the ground level and platform control panels are in the ON position.
- Battery cut-off option: turn the battery cut-off to the ON position, ▶ OPTIONS: BATTERY CUT-OFF.



- Turn the ignition switch to the ON position.

Result:

- The ground level display screen, ▶ GROUND LEVEL DISPLAY SCREEN.

Note: secondary protection system option SPS, ▶ OPTIONS: SECONDARY PROTECTION SYSTEM SPS.

Note: the horn sounds twice and an alert page is displayed on the ground level display screen when the machine is turned on without starting the diesel engine within 10 seconds.

#### SWITCH OFF THE MACHINE



- Turn the ignition switch to the OFF position.
- Battery cut-off option: turn the battery cut-off to the OFF position, ▶ OPTIONS: BATTERY CUT-OFF.

#### START THE DIESEL ENGINE

- Switch on the machine.
- Wait for the preheat cycle to finish, ▶ GROUND LEVEL DISPLAY SCREEN.
- Start the diesel engine, ▶ START BUTTON and ▶ START MODE BUTTON if the outside temperature is below -10 °C.
- If the diesel engine does not start:



- Turn the ignition switch to the OFF position, turn it to the ON position.
- Wait for the preheat cycle to finish and try to start the diesel engine.

Note: consult the maintenance staff if the diesel engine fails to start after several attempts.

#### SWITCH OFF THE DIESEL ENGINE

### ⚠ IMPORTANT ⚠

*Wait several minutes for the diesel engine to cool down before stopping it after intensive use.*

- Turn the ignition key to the OFF position  or press the emergency stop button (OFF position).

#### POSITION THE PLATFORM

- Ensure that the turntable is unlocked, ▶ SAFETY COMPONENTS: TURNTABLE LOCKING PIN.

Note: it is essential that the turntable is locked when the machine is being transported and lifted, ▶ TRANSPORT AND LIFTING: TRANSPORT INSTRUCTIONS and ▶ TRANSPORT AND LIFTING: LIFTING INSTRUCTIONS.

- Start the diesel engine.



- Push and hold the activation switch to the right (ground level controls position).
- Use the appropriate control buttons to position the platform.
- Release the activation switch.

#### ACTIVATE SIMULTANEOUS FUNCTIONS

2 machine functions can be activated simultaneously.

Note: the audible warning sounds twice when the machine's functions cannot be activated simultaneously.

#### EMERGENCY STOP

- Push the emergency stop button into the OFF position.

## USE FROM THE PLATFORM CONTROL PANEL

### ⚠ IMPORTANT ⚠

☞ **CONTROL PANEL AND SAFETY DEVICES IN THE PLATFORM** for detailed information about the platform controls.

**Make sure that the platform is level before putting the machine in working position, ☞ OPERATING THE MACHINE: TRANSPORT/WORKING POSITION. Key lock option for turntable covers: to guarantee access to the emergency controls, it is mandatory to unlock the right-hand turntable cover before using the machine from the platform.**

### TURN THE MACHINE ON/OFF

☞ OPERATION FROM THE GROUND LEVEL CONTROL PANEL.

### START THE DIESEL ENGINE

- Switch on the machine.
  - Wait for the preheat cycle to finish, ☞ PREHEAT INDICATOR LIGHT.
  - Start the diesel engine, ☞ START BUTTON.  
Note: ☞ OPERATION FROM THE GROUND LEVEL CONTROL PANEL if the outside temperature is below -10 °C.
  - If the diesel engine does not start:
    - Press the emergency stop button (OFF position), pull it or turn it clockwise and release it to put it in the ON position.
    - Wait for the preheat cycle to finish and try to restart the diesel engine.
- Note: consult the maintenance staff if the diesel engine fails to start after several attempts.

### SWITCH OFF THE DIESEL ENGINE

### ⚠ IMPORTANT ⚠

**Wait several minutes for the diesel engine to cool down before stopping it after intensive use.**

- Push the emergency stop button into the OFF position.

### DRIVE, STEER AND BRAKE THE MACHINE

### ⚠ IMPORTANT ⚠

**Always refer to the colors of the arrows on the chassis and on the control panel in the platform before driving/steering the machine.**

- Ensure that the turntable is unlocked, ☞ SAFETY COMPONENTS: TURNTABLE LOCKING PIN.  
Note: it is essential that the turntable is locked when the machine is being transported and lifted, ☞ TRANSPORT AND LIFTING: TRANSPORT INSTRUCTIONS and ☞ TRANSPORT AND LIFTING: LIFTING INSTRUCTIONS.
- Start the diesel engine.
- Set the driving speed switch to the desired speed.
- Set the steering mode switch to the desired mode.
- Press and hold down the foot switch.
- Use the driving/steering control handle to drive, steer and brake the machine.
- Release the foot switch.

### POSITION THE PLATFORM

- Ensure that the turntable is unlocked, ☞ SAFETY COMPONENTS: TURNTABLE LOCKING PIN.  
Note: it is essential that the turntable is locked when the machine is being transported and lifted, ☞ TRANSPORT AND LIFTING: TRANSPORT INSTRUCTIONS and ☞ TRANSPORT AND LIFTING: LIFTING INSTRUCTIONS.
- Start the diesel engine.
- Press and hold down the foot switch.
- Use the appropriate switches and control handles to position the platform.
- Release the foot switch.

### ACTIVATE SIMULTANEOUS FUNCTIONS

4 machine functions can be activated simultaneously.

Note: the audible warning sounds twice when the machine's functions cannot be activated simultaneously.

### EMERGENCY STOP

- Push the emergency stop button into the OFF position.



## DIESEL ENGINE AUTOMATIC STOP SYSTEM "STOP AND GO"

Note: the illustration shows a standard platform.

Note: diesel engine information pictograms indicate the status of the diesel engine and the system, <img alt="arrow pointing left" data-bbox="105 108 118 121"/> GROUND LEVEL DISPLAY SCREEN: DISPLAY ZONES: DIESEL ENGINE INFORMATION PICTOGRAMS.

### DIESEL ENGINE AUTOMATIC STOP

Depending on the conditions and when the foot switch  is released, the diesel engine is automatically stopped by the diesel engine automatic stop system "stop and go":

- The preheat indicator light  flashes.
- An alert page is displayed, <img alt="arrow pointing left" data-bbox="105 215 118 228"/> GROUND LEVEL DISPLAY SCREEN: ALERT PAGE AND FAULT PAGE.
- The orange rotating beacon light  comes on (cycle: on = 1 second, off = 1 second).

Note: when the permanent orange rotating beacon light is activated, the orange rotating beacon light changes from "continuous operation" status to "cycle: on = 1 second, off = 1 second" status.

### DIESEL ENGINE MANUAL RESTART

#### **IMPORTANT**



*It is recommended to restart the diesel engine when a low battery fault occurs:*

- The battery indicator light  is on.
- The audible alarm sounds intermittently.
- The "minor low battery fault" alert page is displayed, <img alt="arrow pointing left" data-bbox="105 391 118 404"/> GROUND LEVEL DISPLAY SCREEN: ALERT PAGE AND FAULT PAGE.

- Press on the foot switch  and hold it down to restart the diesel engine.

Note: when a preheat is required, the preheat indicator light  comes on and the preheat page is displayed, <img alt="arrow pointing left" data-bbox="105 455 118 468"/> GROUND LEVEL DISPLAY SCREEN: PREHEAT PAGE.

Result:

- The diesel engine starts.
- The preheat indicator light  goes out.
- The alert page is no longer displayed.
- The orange rotating beacon light  goes out.

Note: when the permanent orange rotating beacon light is activated, the orange rotating beacon light changes from "cycle: on = 1 second, off = 1 second" status to "continuous operation" status.

### DIESEL ENGINE AUTOMATIC RESTART

Depending on the conditions, when the battery voltage is very low and the foot switch  is released, the diesel engine automatically restarts.

In this case, the diesel engine automatic stop system "stop and go" is deactivated. It will be automatically reactivated when the machine is turned off and then turned back on with sufficient battery voltage.

Note: the diesel engine automatic restart is disabled when the left-hand turntable cover is open.

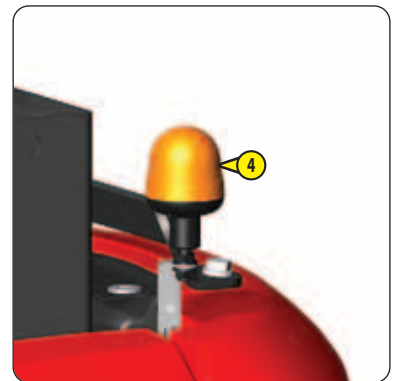
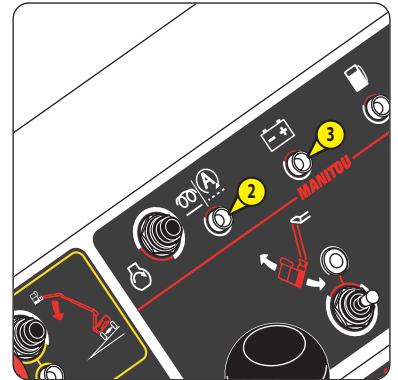
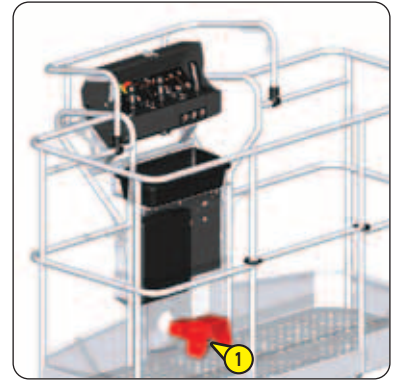







## LOCKED FUNCTIONS

Some machine functions are locked :













- When the platform load has reached maximum load capacity (overload alarm).
- If the tilt of the chassis is greater than the maximum authorized value (tilt warning).
- When an oscillating axle locking fault occurs (oscillation lock fault).

### MACHINE IN TRANSPORT POSITION

#### FROM THE GROUND LEVEL CONTROL PANEL

	OVERLOAD WARNING	TILT WARNING
		OSCILLATION LOCK FAULT
Tilt the platform/jib arm (up/down)		
Raise/lower the jib arm		
Extend the telescopic arm		
Raise the main arm		
Raise the secondary arm		
Turn the turntable (to the left/right)		

#### FROM THE PLATFORM CONTROL PANEL

	OVERLOAD WARNING	TILT WARNING
		OSCILLATION LOCK FAULT
Drive (forward/backward)		
Steer (to the left/right)		
Turn the platform (to the left/right)		
Tilt the platform/jib arm (up/down)		
Raise/lower the jib arm		
Extend the telescopic arm		
Raise the main arm		
Raise the secondary arm		
Turn the turntable (to the left/right)		

**MACHINE IN WORKING POSITION**

**FROM THE GROUND LEVEL CONTROL PANEL**

	OVERLOAD WARNING	TILT WARNING
		OSCILLATION LOCK FAULT
Tilt the platform/jib arm (up/down)	🔒	
Raise/lower the jib arm	🔒	
Extend/retract the telescopic arm	🔒	
Raise/lower the main arm	🔒	
Raise/lower the secondary arm	🔒	
Turn the turntable (to the left/right)	🔒	

**FROM THE PLATFORM CONTROL PANEL**

	OVERLOAD WARNING	TILT WARNING
		OSCILLATION LOCK FAULT
Drive (forward/backward)	🔒	🔒
Steer (to the left/right)	🔒	🔒
Turn the platform (to the left/right)	🔒	
Raise/lower the jib arm	🔒	
Extend the telescopic arm	🔒	🔒
Retract the telescopic arm	🔒	
Raise the main arm	🔒	🔒
Lower the main arm	🔒	
Raise the secondary arm	🔒	🔒
Lower the secondary arm	🔒	
Turn the turntable (to the left/right)	🔒	

## EMERGENCY CONTROLS

### ⚠ IMPORTANT ⚠

*This procedure should be read and fully understood by the operator and any other persons likely to be involved with working on the machine in the event of a breakdown or a person getting trapped in the platform.*

### SHOULD THE USER FEEL ILL - PRIORITY CONTROLS FROM THE GROUND

If the operator in the platform should fall ill or find himself incapable of maneuvering, somebody on the ground can take over the machine controls using the ground level control panel.

1- If the diesel engine has been started:

- Push and hold the activation switch ① to the right  (ground level controls position).
- Use the appropriate control buttons to position the platform.
- Release the activation switch.

2- If the diesel engine has stopped and the emergency stop button in the platform is in the ON position (the ground level display screen is on):

- Start the diesel engine.
- Push and hold the activation switch ① to the right  (ground level controls position).
- Use the appropriate control buttons to position the platform.
- Release the activation switch.

3- If the diesel engine has stopped and the emergency stop button in the platform is in the OFF position (the ground level display screen is off):

- Push and hold the activation switch ① to the right  (ground level controls position).
- Wait for the preheat cycle to finish and start up the diesel engine.
- Use the appropriate control buttons to position the platform.
- Release the activation switch.

4- If the control buttons are not working:

- ⚠ IF THERE IS A BREAKDOWN - EMERGENCY CONTROLS FROM THE GROUND.

### IF THERE IS A BREAKDOWN - EMERGENCY CONTROLS FROM THE PLATFORM

#### ⚠ IMPORTANT ⚠

*The backup pump should be activated for a maximum of 4 minutes, then wait 10 minutes before reactivating the pump for a new 4 minute cycle.*

*Do not try to use the functions simultaneously.*

Activate the machine's functions using the backup pump when the diesel engine is not operational:

- Press and hold down the backup pump button ①.
- Use the appropriate switch or control handle to position the platform.
- Release the backup pump button.

Note: it is not possible to drive/steer the machine.

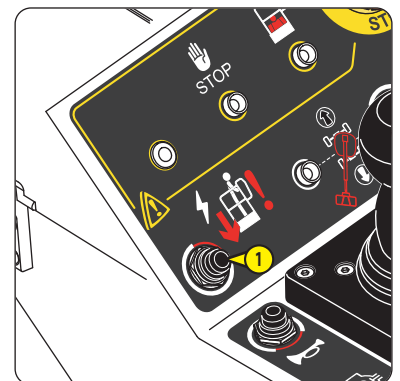
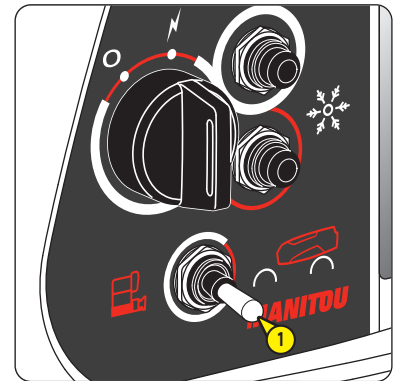

**IF THERE IS A BREAKDOWN - EMERGENCY CONTROLS FROM THE GROUND**

**⚠ IMPORTANT ⚠**

*The tilt warning and overload alarm may no longer be active when the emergency controls are in use. Activation of functions likely to tip over or imbalance the machine is prohibited.  
The backup pump should be activated for a maximum of 4 minutes, then wait 10 minutes before reactivating the pump for a new 4 minute cycle.*

Note: the illustrations show a 160 ATJ.

Activate the machine's functions using the backup pump when the control system is not operational:

- Open the right-hand turntable cover.
- Battery cut-off option: make sure that the battery cut-off is in the ON position.
- Locate the various components of the emergency controls:
  - Backup pump button ①.
  - Proportional distributor ② and manual controls ②A to ②D.
  - Lever ③.
  - Secondary distributor ④ and valve buttons ④A to ④D.
- Activate the machine's functions described on the following pages to position the platform.

Note: ⏪ STICKERS: BACKUP PUMP ⑤ and ⏪ STICKERS: EMERGENCY CONTROL PROCEDURE ⑥ and ⑦.

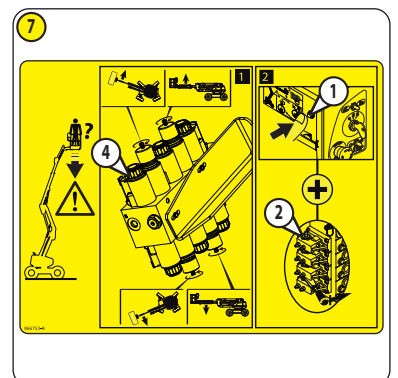
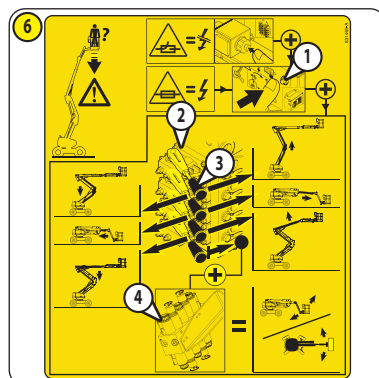
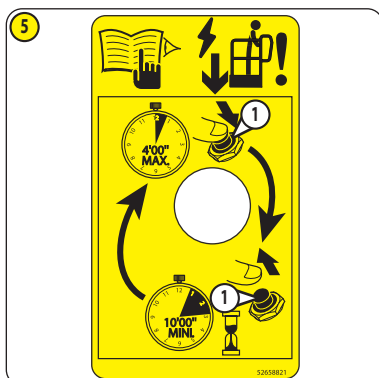
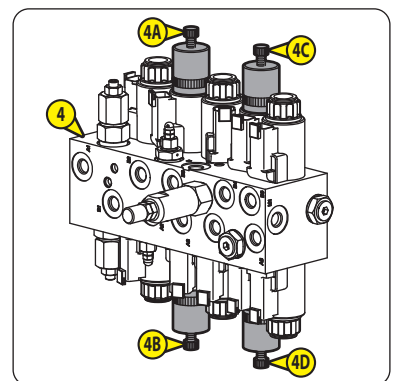
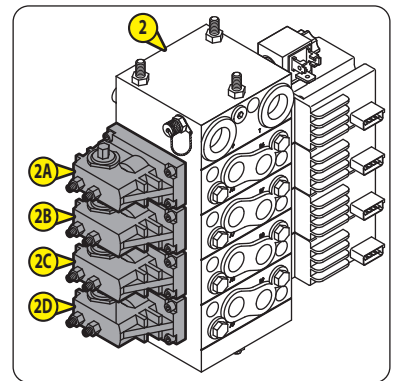
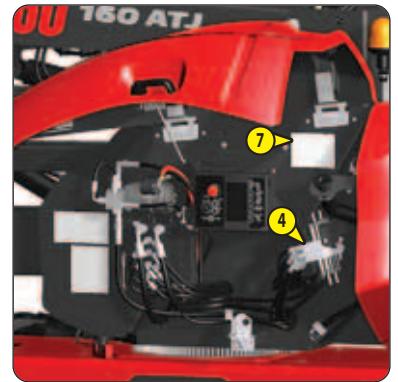
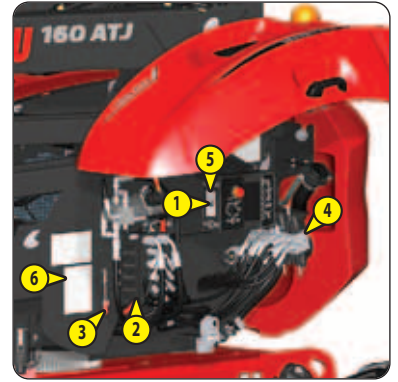

### A- RAISE THE SECONDARY ARM

- 1- Place the lever **3** on the manual control **2A**.
- 2- Press and hold down the backup pump button **1**.
- 3- Push the lever to the right to raise the secondary arm, stop when the desired position is reached. Release the backup pump button.

Note: remove the lever, put it back in place and close the right-hand turntable cover when no other machine functions are necessary.

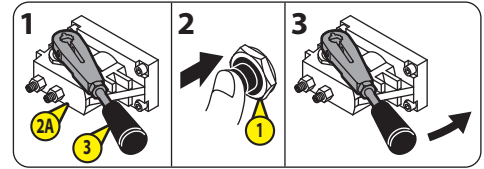

### B- LOWER THE SECONDARY ARM

- 1- Place the lever **3** on the manual control **2A**.
- 2- Press and hold down the backup pump button **1**.
- 3- Push the lever to the left to lower the secondary arm, stop when the desired position is reached. Release the backup pump button.

Note: remove the lever, put it back in place and close the right-hand turntable cover when no other machine functions are necessary.

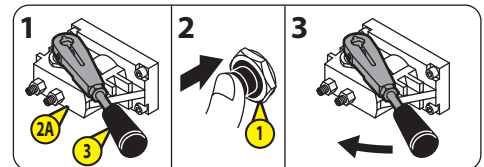

### C- EXTEND THE TELESCOPIC ARM

- 1- Place the lever **3** on the manual control **2B**.
- 2- Press and hold down the backup pump button **1**.
- 3- Push the lever to the right to raise the telescopic arm, stop when the desired position is reached. Release the backup pump button.

Note: remove the lever, put it back in place and close the right-hand turntable cover when no other machine functions are necessary.

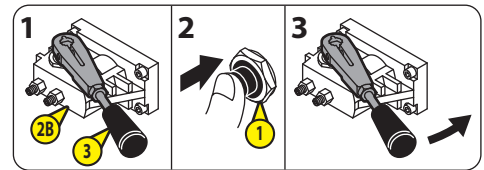

### D- RETRACT THE TELESCOPIC ARM

- 1- Place the lever **3** on the manual control **2B**.
- 2- Press and hold down the backup pump button **1**.
- 3- Push the lever to the left to retract the telescopic arm, stop when the desired position is reached. Release the backup pump button.

Note: remove the lever, put it back in place and close the cover

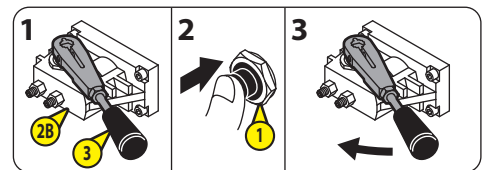

### E- RAISE THE MAIN ARM

- 1- Place the lever **3** on the manual control **2C**.
- 2- Press and hold down the backup pump button **1**.
- 3- Push the lever to the right to raise the main arm, stop when the desired position is reached. Release the backup pump button.

Note: remove the lever, put it back in place and close the right-hand turntable cover when no other machine functions are necessary.

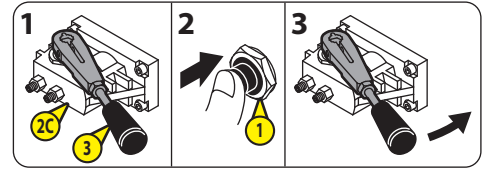

### F- LOWER THE MAIN ARM

- 1- Place the lever **3** on the manual control **2C**.
- 2- Press and hold down the backup pump button **1**.
- 3- Push the lever to the left to lower the main arm, stop when the desired position is reached. Release the backup pump button.

Note: remove the lever, put it back in place and close the right-hand turntable cover when no other machine functions are necessary.

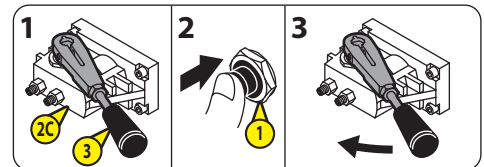

### G- RAISE THE JIB ARM

- 1- Place the lever **3** on the manual control **2D**.
- 2- Turn the button of the valve **4A** clockwise until it stops.
- 3- Press and hold down the backup pump button **1**.
- 4- Push the lever to the right to raise the jib arm, stop when the desired position is reached. Release the backup pump button.
- 5- Turn the button of the valve **4A** anticlockwise until it stops.

Note: remove the lever, put it back in place and close the right-hand turntable cover when no other machine functions are necessary.

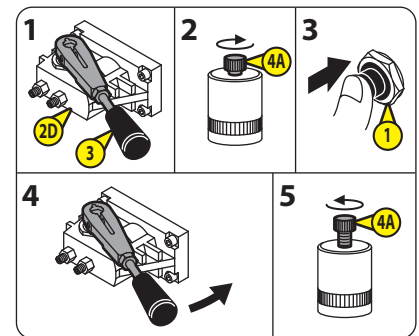

### H- LOWER THE JIB ARM

- 1- Place the lever **3** on the manual control **2D**.
- 2- Turn the button of the valve **4B** anticlockwise until it stops.
- 3- Press and hold down the backup pump button **1**.
- 4- Push the lever to the right to lower the jib arm, stop when the desired position is reached. Release the backup pump button.
- 5- Turn the button of the valve **4B** clockwise until it stops.

Note: remove the lever, put it back in place and close the right-hand turntable cover when no other machine functions are necessary.

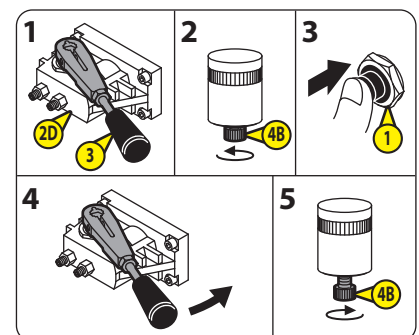

### I- TURN THE TURNTABLE TO THE LEFT

- 1- Place the lever **3** on the manual control **2D**.
  - 2- Turn the button of the valve **4C** clockwise until it stops.
  - 3- Press and hold down the backup pump button **1**.
  - 4- Push the lever to the right to turn the turntable to the left, stop when the desired position is reached. Release the backup pump button.
  - 5- Turn the button of the valve **4C** anticlockwise until it stops.
- Note: remove the lever, put it back in place and close the right-hand turntable cover when no other machine functions are necessary.

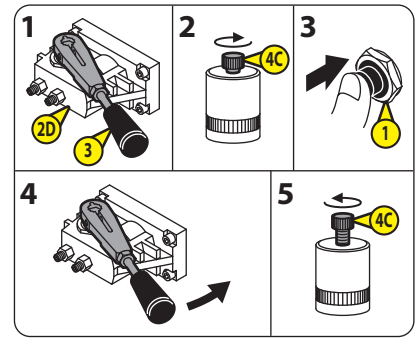

### J- TURN THE TURNTABLE TO THE RIGHT

- 1- Place the lever **3** on the manual control **2D**.
  - 2- Turn the button of the valve **4D** anticlockwise until it stops.
  - 3- Press and hold down the backup pump button **1**.
  - 4- Push the lever to the right to turn the turntable to the right, stop when the desired position is reached. Release the backup pump button.
  - 5- Turn the button of the valve **4D** clockwise until it stops.
- Note: remove the lever, put it back in place and close the right-hand turntable cover when no other machine functions are necessary.

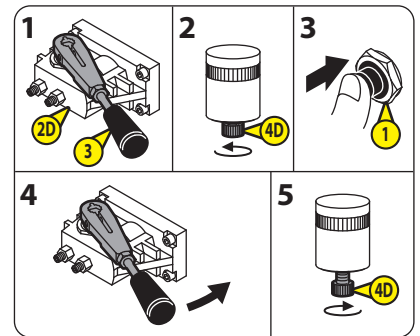

## STANDARD EQUIPMENT

### OSCILLATING FRONT AXLE

#### **⚠ IMPORTANT ⚠**

*When driving the machine in working position, only 3 wheels could be in contact with the ground and the machine may tip over (illustration **A**).*

**B**: axle oscillation is unlocked when the machine is in transport position.

**C**: axle oscillation is locked when the machine is in working position.

Note: some machine functions are locked when an oscillating axle locking fault occurs, **⚠ OPERATING THE MACHINE. LOCKED FUNCTIONS.**

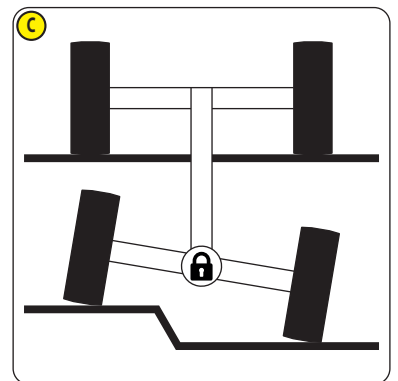
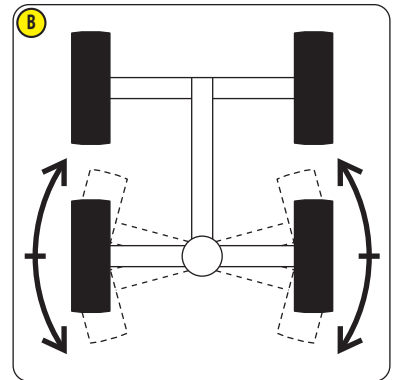
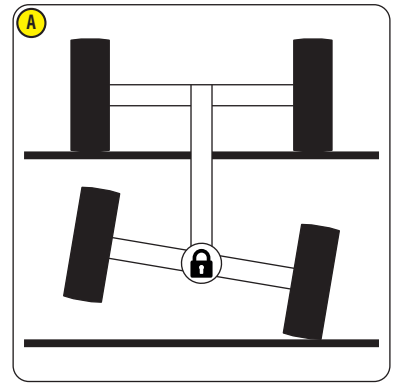

## OPTIONS

### KEY LOCK FOR TURNTABLE COVERS

#### ⚠ IMPORTANT ⚠

To guarantee access to the emergency controls, it is mandatory to unlock the right-hand turntable cover before using the machine from the platform.

### BATTERY CUT-OFF

Note: the illustration shows a 160 ATJ.

2 positions:

- OFF: the handle ① is vertical.
- ON: the handle ① is horizontal.

Note: ⚠ STICKERS: BATTERY CUT-OFF ③A.

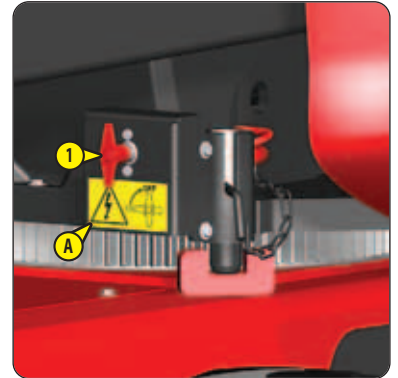

### 230 V ELECTRIC POWER SOCKET IN THE PLATFORM

Note: the illustrations show a 160 ATJ with a standard platform.

This option includes:

- 1 plug ① at the rear of the turntable.
- 1 electric power socket ② in the platform.
- 1 electric unit ③A with 1 30 mA residual-current circuit breaker.

#### INSTRUCTIONS: ELECTRIC POWER SOCKET IN THE PLATFORM

##### ⚠ IMPORTANT ⚠

Connect the plug to a 230 V/50 Hz power source delivering 16 A.

Only connect electrical appliances that work with 230 V/50 Hz, 16 A maximum.

Do not connect extension cords, power supply bars or plugs with multiple sockets to the electric power socket.

- Connect the plug ① to a power source.
- Plug 1 electrical appliance into the power socket ②.
- Switch on the electrical appliance.
- Power down the electrical appliance when the work has been completed.
- Disconnect the electrical plug.

#### INSTRUCTIONS: RESIDUAL-CURRENT CIRCUIT BREAKER

To reset the residual-current circuit breaker:

- Turn off the power to the electrical appliance.
- Put the machine in transport position, ⚠ OPERATING THE MACHINE: TRANSPORT/WORKING POSITION.
- Fully lower the jib arm.
- Open the electrical box cover panel ③A.
- Push the switch ③B to the ON position.

Result:

- The switch must remain in the ON position, the indicators ③C and ③D should be red.
- Close the electrical box cover panel.

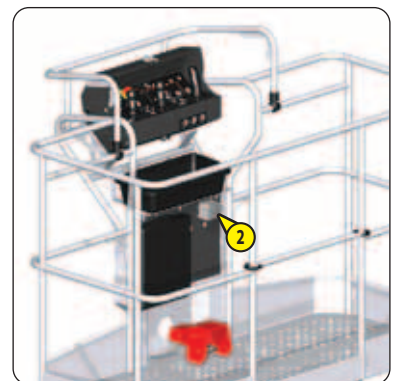
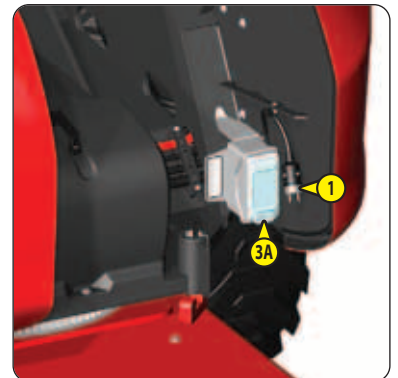

## BATTERY HEATER

### ⚠ IMPORTANT ⚠

*Plug the battery heater to a 230 V/50 Hz power source delivering 16 A protected by a 30 mA residual-current circuit breaker.*

*The machine should be switched off before connecting the battery heater.*

Note: the illustration shows a 160 ATJ.

The battery heater is designed to heat the battery when the outside temperature is below -10 °C.

- Locate the electrical plug ①.
- Connect it to a power source.
- Wait for the desired heating time and disconnect it.

Note: the heating time depends on the ambient temperature and other factors.  
Adjust the heating time, observing the conditions for starting the diesel engine.

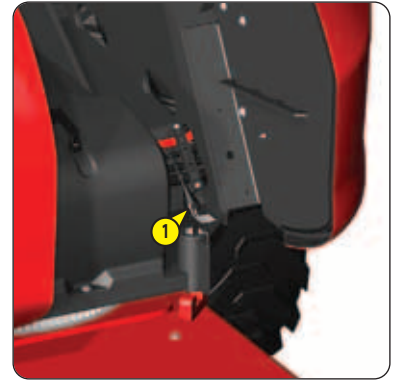

## HYDRAULIC OIL HEATER

### ⚠ IMPORTANT ⚠

*Plug the hydraulic oil heater to a 230 V/50 Hz power source delivering 16 A protected by a 30 mA residual-current circuit breaker.*

*Before connecting the hydraulic oil heater:*

- *The machine must be in transport position, <math>\triangleleft</math> OPERATING THE MACHINE: TRANSPORT/WORKING POSITION.*
  - *The jib arm must be fully lowered.*
- *The hydraulic oil level must be checked, <math>\triangleleft</math> 3 - MAINTENANCE: DAILY MAINTENANCE.*
  - *The machine should be switched off.*

The hydraulic oil heater is designed to heat the hydraulic oil when the outside temperature is below -15 °C.

- Open the left-hand turntable cover.
- Locate the electrical plug ①.
- Connect it to a power source.
- Wait for the desired heating time and disconnect it.
- Close the left-hand turntable cover.

Note: the heating time depends on the ambient temperature and other factors.  
Adjust the heating time, observing the conditions for machine operation.

Note: the illustration shows 2 plugs for the hydraulic oil heater (option) and for the engine block heater (option) with the corresponding stickers from left to right.

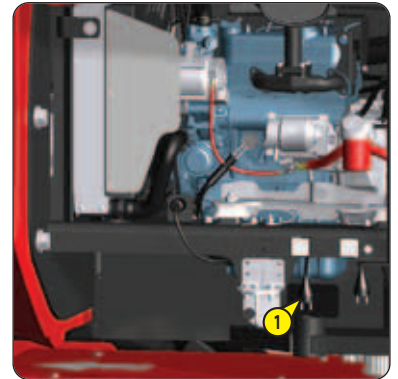

## ENGINE BLOCK HEATER

### **⚠ IMPORTANT ⚠**

*Plug the engine block heater to a 230 V/50 Hz power source delivering 16 A protected by a 30 mA residual-current circuit breaker.*

*The machine should be switched off before connecting the engine block heater.*

The engine block heater is designed to heat the engine block when the outside temperature is below -10 °C.

- Locate the electrical plug **1**.
- Connect it to a power source.
- Wait for the desired heating time and disconnect it.

Note: the heating time depends on the ambient temperature and other factors.  
Adjust the heating time, observing the conditions for starting the diesel engine.

Note: the illustration shows 2 plugs for the hydraulic oil heater (option) and for the engine block heater (option) with the corresponding stickers from left to right.

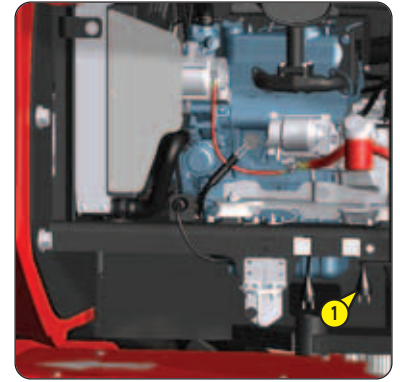

## ELECTRIC GENERATOR

The electric generator option includes:

- 1 electric generator ①, located under the left-hand turntable cover, with 1 residual-current circuit breaker.
- 1 electric generator button ② on the platform control panel.
- 230 V 3.5 kW electric generator option:
  - 1 electric power socket ③ in the platform supplying 230 V/50 Hz, 16 A maximum.
- 230 V 5 kW electric generator option:
  - 2 electric power sockets ④ in the platform each supplying 230 V/50 Hz, 16 A maximum.

Note: <img alt="arrow icon" data-bbox="115 212 130 225"/> STICKERS: 110 V ELECTRICAL SYSTEM (OPTION) or <img alt="arrow icon" data-bbox="115 225 130 238"/> STICKERS: 230 V ELECTRICAL SYSTEM (OPTION).

### INSTRUCTIONS: ELECTRIC POWER SOCKET IN THE PLATFORM

#### **⚠ IMPORTANT ⚠**

*Only connect electrical appliances that work with 230 V/50 Hz, 16 A maximum (230 V 3.5 kW electric generator option and 230 V 5 kW electric generator option).*

*Do not connect extension cords, power supply bars or plugs with multiple sockets to the electric power socket(s). The electric generator is automatically stopped when any machine function is activated. It automatically restarts when the machine's functions are no longer activated.*

*Overvoltages could occur when the electric generator is started. Make sure that the electrical equipment is powered down before:*

- Starting the electric generator.
- Activating the machine's functions when the electric generator is started.

Note: the illustrations show a standard platform.

Note: the diesel engine must be started.

- Press and release the electric generator button ② to start the electric generator.
- 230 V 3.5 kW electric generator option:
  - Plug 1 electrical appliance into the power socket ③.
- 230 V 5 kW electric generator option:
  - Plug 1 or 2 electrical appliances into the power socket(s) ④.
- Power on the electrical appliances.
- Power down the electrical appliances when the work has been completed.
- Press and release the electric generator button to stop the electric generator.

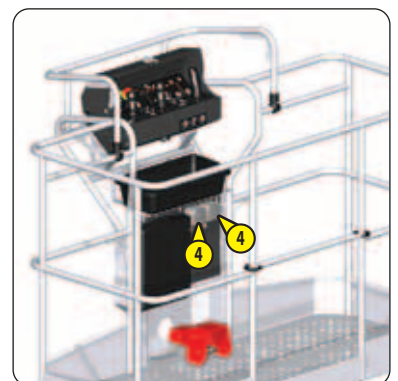
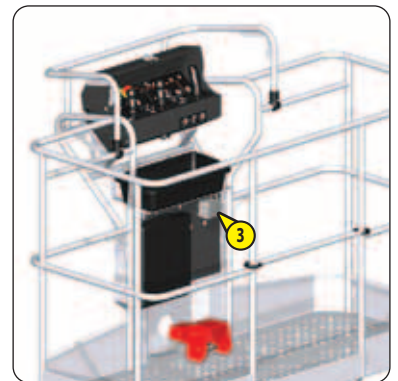
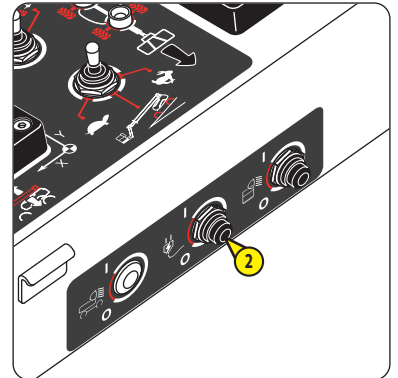
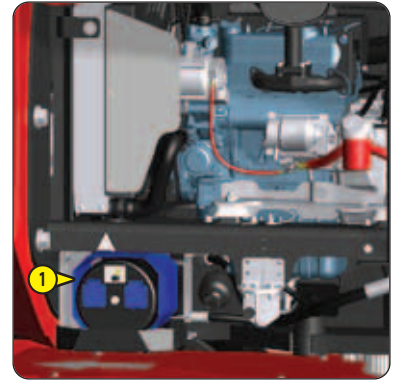

## INSTRUCTIONS: RESIDUAL-CURRENT CIRCUIT BREAKER

To reset the residual-current circuit breaker:

- Power down the electrical appliance(s).
- Press and release the electric generator button **2** to stop the electric generator.
- Put the machine in transport position, <img alt="arrow pointing left" data-bbox="105 115 115 125"/> OPERATING THE MACHINE: TRANSPORT/WORKING POSITION.
- Fully lower the jib arm.
- Open the left-hand turntable cover.
- Locate the switch **1A** on the electric generator **1**.
- Push it to the ON position.

Result:

- The switch must remain in the ON position, the indicator **1B** should be red.
- Press and release the electric generator button **2** to start the electric generator.
- Check that the switch **1A** remains in the ON position and that the indicator **1B** is red.
- Close the left-hand turntable cover.

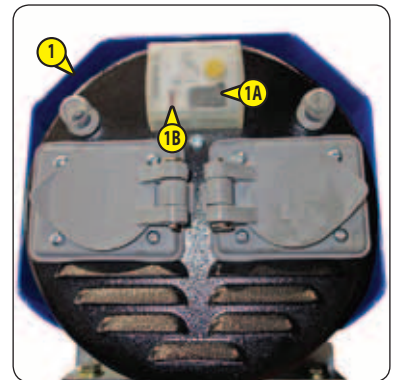
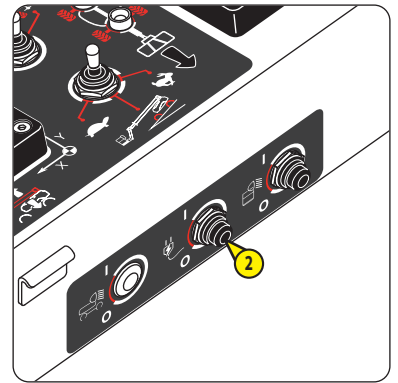

## PLATFORM WORKLIGHT

Note: the illustration shows a standard platform.

### INSTRUCTIONS

Note: the machine should be turned on.

- Press and release the worklight button **2** to turn the worklight **1** on or off.

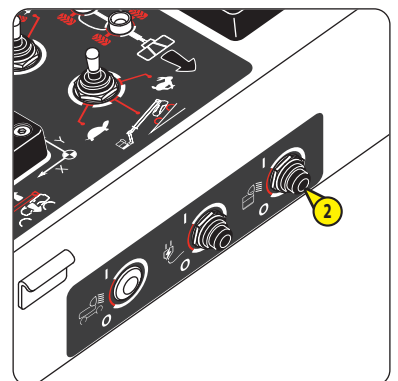

### ADJUSTMENT

Use the handle **1A** to direct the worklight **1** left, right, up or down.

The worklight can be moved along the guardrails:

- Loosen the tightening wheel **1B**.
- Move the worklight.
- Do the tightening wheel back up.

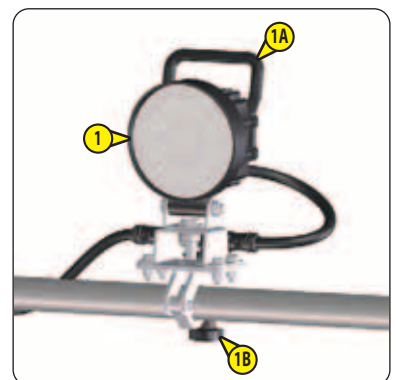

## TURNTABLE SLEWING ALARM

### ⚠ IMPORTANT ⚠

Always refer to the colors of the arrows on the chassis and on the control panel in the platform before driving/steering the machine.

### TURNTABLE SLEWING ALARM

It occurs when the turntable angle is greater than 90° (left or right) in relation to the neutral position:

- The turntable slewing indicator light ① comes on.
- The driving/steering functions are locked.

Note: the audible alarm sounds twice when trying to drive.

Unlock the driving/steering functions:

- Press and release the turntable slewing button ②.

Result:

- The turntable slewing indicator light flashes.

Note: the turntable slewing alarm will occur again if the driving/steering control handle is not actioned in the next 5 seconds.

Stop the turntable slewing alarm and unlock the driving/steering functions:

- Turn the turntable until the turntable angle is less than 90° (left or right) in relation to the neutral position.

Result:

- The turntable slewing indicator light goes out.

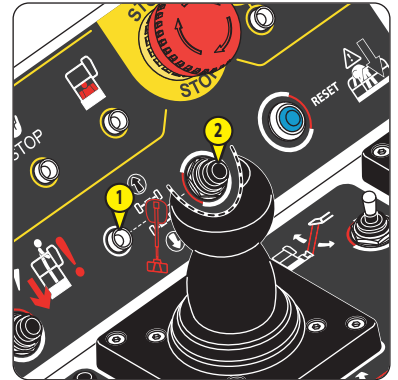
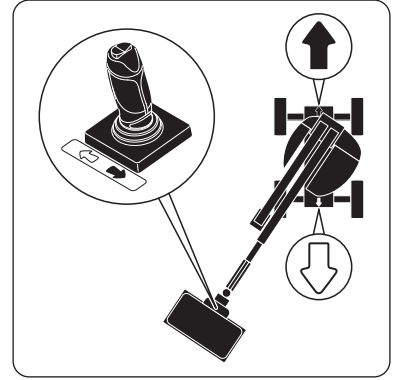

## SECONDARY PROTECTION SYSTEM SPS

### ⚠ IMPORTANT ⚠

*Operate the machine's functions extremely carefully during attempts at clearance.*

*If the audible alarm sounds quickly and intermittently and the flashing light SPS ① flashes rapidly: the machine can be used but the secondary protection system SPS is deactivated, consult maintenance personnel.*

Note: the audible alarm sounds once and the flashing light SPS ① flashes several times when the machine is powered up. This indicates that the secondary protection system SPS is operating correctly.

Note: the flashing light SPS ① can be blue or red depending on the country.

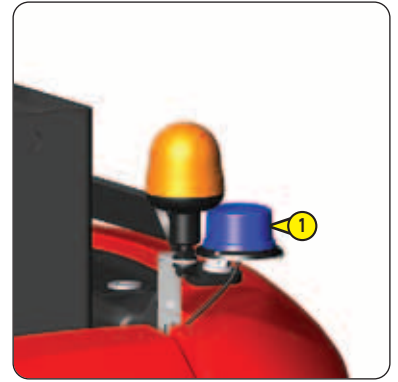

### SECONDARY PROTECTION SYSTEM SPS ALERT

It occurs when you are trapped between the safety cable SPS ② and a structure ④:

- All of the machine's functions are stopped and locked.
- An alert page is displayed on the ground level display screen.
- The horn sounds intermittently and the flashing light SPS ① flashes.

If you are still trapped between the safety cable SPS and the structure:

- Press and release the reset button SPS ③.

Result:

- The machine's functions are unlocked, use them to get free.
- The alert page will no longer be displayed when you are no longer trapped.
- The horn will stop sounding and the flashing light SPS goes out when you are no longer trapped.

If you are no longer trapped between the safety cable SPS and the structure:

- Press and release the reset button SPS ③.

Result:

- All of the machine's functions are unlocked.
- The alert page is no longer displayed.
- The horn stops and the flashing light SPS goes out.

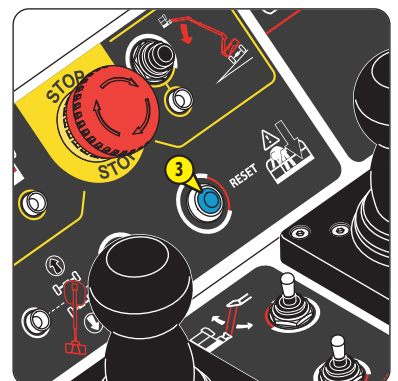
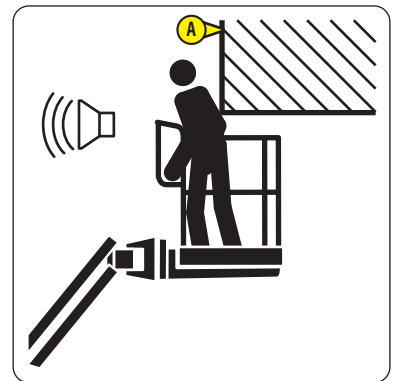
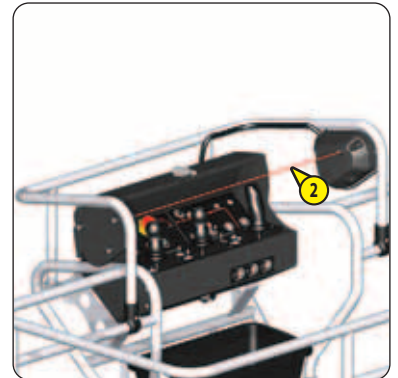



## TRANSPORT AND LIFTING

### TRANSPORT INSTRUCTIONS

#### ⚠ IMPORTANT ⚠

Check that the safety instructions associated with the transport vehicle have been correctly applied before loading the machine and ensure that the driver of the vehicle has been informed of the dimensional characteristics and total weight of the machine.

Ensure that the transport vehicle has adequate dimensions and load capacity for transporting the machine, <math>\triangleleft</math> SPECIFICATIONS and STICKERS.

It is essential that the turntable is locked when the machine is being transported, <math>\triangleleft</math> SAFETY COMPONENTS: TURNTABLE LOCKING PIN.

Covers must be closed and locked (if applicable) while the machine is being transported.

### LOADING/UNLOADING THE MACHINE

#### ⚠ IMPORTANT ⚠

The transport vehicle must be parked on a level surface and the wheels must be chocked to prevent it from rolling during loading and unloading of the machine.

Turntable rotation is prohibited while the machine is being loaded onto the transport vehicle and during unloading.

The turntable must be locked before loading the machine onto the transport vehicle and before unloading it, <math>\triangleleft</math> SAFETY COMPONENTS: TURNTABLE LOCKING PIN.

The machine must be loaded or unloaded using a winch if the loading ramps are slippery, <math>\triangleleft</math> FREEWHEELING FOR WINCHING.

The angle of the loading ramps must not exceed the maximum slope accessible value, <math>\triangleleft</math> SPECIFICATIONS.

The machine must be loaded and unloaded using a crane if the angle of the loading ramps exceeds the maximum slope accessible value, <math>\triangleleft</math> TRANSPORT FOR WINCHING: LIFTING INSTRUCTIONS.



Note: the illustration shows a 160 ATJ.

### LOADING THE MACHINE ONTO THE TRANSPORT VEHICLE

- From the ground level control panel:
  - Start the diesel engine.
  - Put the platform in transport position; put the turntable in neutral position, <math>\triangleleft</math> OPERATING THE MACHINE: TRANSPORT/WORKING POSITION.
  - Fully lower the jib arm.
- Lock the turntable, <math>\triangleleft</math> SAFETY COMPONENTS: TURNTABLE LOCKING PIN.
- Get into the platform.
- Put the platform in neutral position, <math>\triangleleft</math> OPERATING THE MACHINE: TRANSPORT/WORKING POSITION.
- Raise the jib arm slightly to prevent the platform hitting the ground or the loading ramps.
- Select ramp speed .
- Drive the machine forward slowly with the platform at the bottom of the slope as shown in the illustration.

### UNLOADING THE MACHINE FROM THE TRANSPORT VEHICLE

Note: the machine is in transport position , <math>\triangleleft</math> CONFIGURING THE MACHINE FOR TRANSPORT on the next page.

- Ensure that the turntable is locked, <math>\triangleleft</math> SAFETY COMPONENTS: TURNTABLE LOCKING PIN.
- From the ground level control panel:
  - Start the diesel engine.
- Get into the platform.
- Raise the jib arm slightly to prevent the platform hitting the ground or the loading ramps.
- Select ramp speed .
- Reverse the machine slowly with the platform at the bottom of the slope as shown in the illustration.

## CONFIGURE THE MACHINE FOR TRANSPORT

### ⚠ IMPORTANT ⚠

Turntable rotation is prohibited once on the transport vehicle except for:

- Putting the turntable into neutral position when the machine is loaded using a crane, <⚠ TRANSPORT AND LIFTING: LIFTING INSTRUCTIONS.
  - Turning the turntable to 12° when the machine is unloaded using a crane, <⚠ TRANSPORT AND LIFTING: LIFTING INSTRUCTIONS.
- The turntable must be locked once on the transport vehicle, <⚠ SAFETY COMPONENTS: TURNABLE LOCKING PIN.

The machine must be transported in transport position **A** or in folded position **B**.

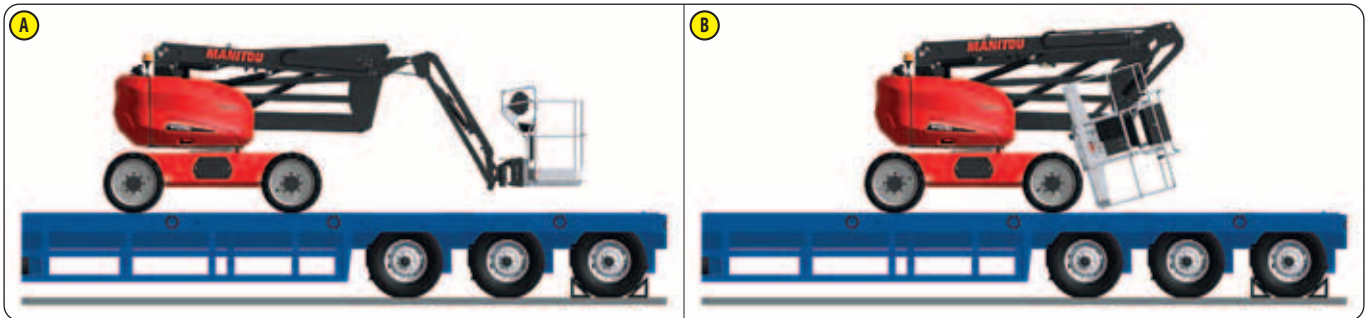

Note: the illustrations show a 160 ATJ.

### TRANSPORT POSITION **A**

Note: the diesel engine has been started. The machine is in transport position. The turntable and the platform are in neutral position. The turntable is locked.

- Fully lower the jib arm.
- Get out of the platform.
- Switch off the machine. Remove the key.

### FOLDED POSITION **B**

Note: the diesel engine has been started. The machine is in transport position. The turntable and the platform are in neutral position. The turntable is locked.

- Turn the platform fully to the left.
- Fully lower the jib arm.
- Get out of the platform.
- From the ground level control panel:
  - Raise the main arm slightly.
  - Tilt the platform/jib arm down completely. Ensure that the platform cannot hit the transport vehicle.
  - Lower the main arm so that the platform is approximately 10 cm from the transport vehicle.
  - Switch off the machine. Remove the key.

### MOVE FROM THE FOLDED POSITION **B** TO THE TRANSPORT POSITION **A**

Note: the turntable is locked.

- From the ground level control panel:
  - Start the diesel engine.
  - Raise the main arm slightly.
  - Tilt the platform/jib arm upward until the platform floor is horizontal. Ensure that the platform cannot hit the transport vehicle.
  - Fully lower the main arm.
- Get into the platform.
- Turn the platform to the right in neutral position, <⚠ OPERATING THE MACHINE: TRANSPORT/WORKING POSITION.
- Get out of the platform.
- Switch off the machine.

**⚠ IMPORTANT ⚠**

Turntable rotation is prohibited once on the transport vehicle.

The turntable must be locked once on the transport vehicle, ⚠ SAFETY COMPONENTS: TURNTABLE LOCKING PIN.

The machine is equipped with 8 anchoring points (⚠ STICKERS: ANCHORING POINT); comply with local, governmental and national regulations in force concerning the minimum number of anchoring points required when transporting a machine.

Make sure that the chains and/or straps are not in contact with the wheels and the machine is correctly anchored to the transport vehicle.

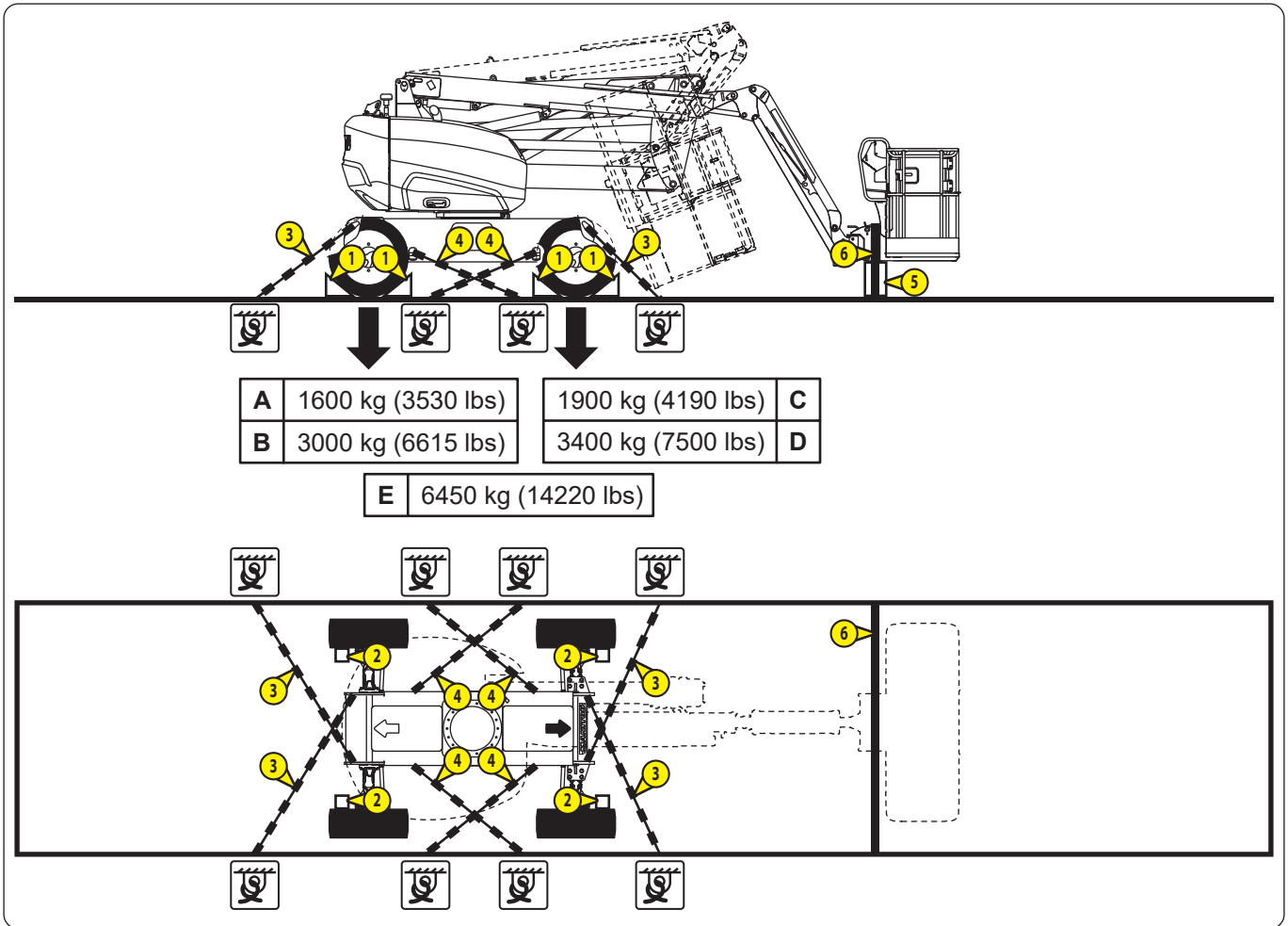

**KEY:**

A	C	LOAD ON 1 WHEEL
B	D	LOAD ON 2 WHEELS
E		TOTAL MASS

Note: the machine is powered down. The machine is in transport position (A) or folded position (B), ⚠ CONFIGURING THE MACHINE FOR TRANSPORT. The turntable is locked.

- Fix chocks (1) to the transport vehicle at the front and rear of each of the machine's wheels.
- Fix chocks (2) to the transport vehicle on the inner side of each of the machine's wheels.
- Secure the machine to the transport vehicle with sufficiently robust straps or chains (3) and/or (4) (according to the regulations in force) attached to the machine's anchoring points, ⚠ STICKERS: ANCHORING POINT.
- Only for transport position (A):
  - Place a wooden block (5) under the overload system as shown in the illustration.
  - Strap the platform down (6). Do not overtighten to avoid damage.

Note: ⚠ STICKERS: ANCHORING 160 ATJ.

**⚠ IMPORTANT ⚠**

Turntable rotation is prohibited once on the transport vehicle.

The turntable must be locked once on the transport vehicle, ⚠ SAFETY COMPONENTS: TURNTABLE LOCKING PIN.

The machine is equipped with 8 anchoring points (⚠ STICKERS: ANCHORING POINT); comply with local, governmental and national regulations in force concerning the minimum number of anchoring points required when transporting a machine.

Make sure that the chains and/or straps are not in contact with the wheels and the machine is correctly anchored to the transport vehicle.

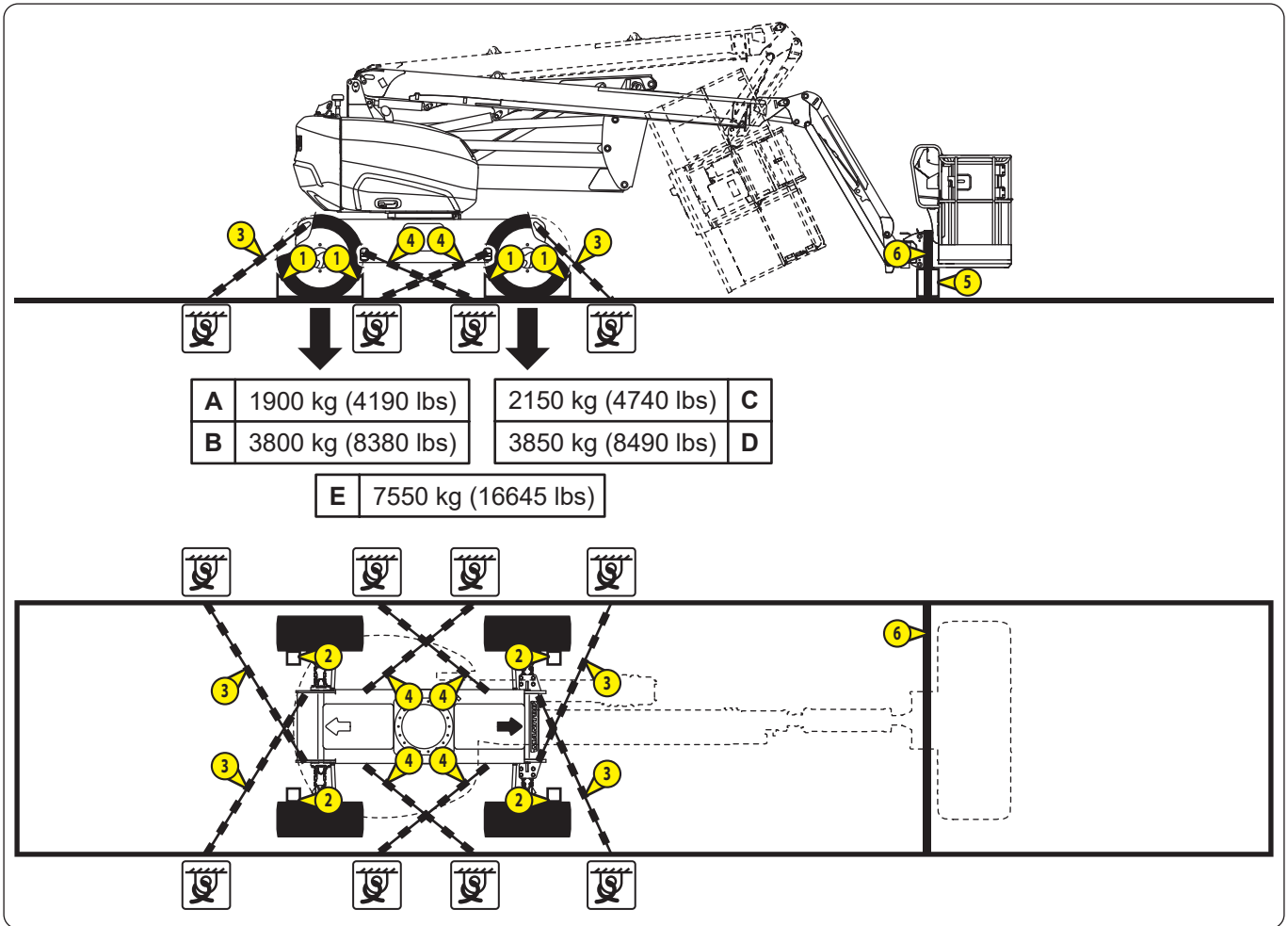

**KEY:**

A	C	LOAD ON 1 WHEEL
B	D	LOAD ON 2 WHEELS
E		TOTAL MASS

Note: the machine is powered down. The machine is in transport position (A) or folded position (B), ⚠ CONFIGURING THE MACHINE FOR TRANSPORT. The turntable is locked.

- Fix chocks (1) to the transport vehicle at the front and rear of each of the machine's wheels.
- Fix chocks (2) to the transport vehicle on the inner side of each of the machine's wheels.
- Secure the machine to the transport vehicle with sufficiently robust straps or chains (3) and/or (4) (according to the regulations in force) attached to the machine's anchoring points, ⚠ STICKERS: ANCHORING POINT.
- Only for transport position (A):
  - Place a wooden block (5) under the overload system as shown in the illustration.
  - Strap the platform down (6). Do not overtighten to avoid damage.

Note: ⚠ STICKERS: ANCHORING 180 ATJ.

## FREEWHEEL FOR WINCHING

### ⚠ IMPORTANT ⚠

The machine must be winched in transport position. Winching the machine in working position is prohibited, ⚠ OPERATING THE MACHINE: TRANSPORT/WORKING POSITION.

Always use a suitable winch for winching the machine.

Before releasing the brakes:

- The machine must be on a level surface.
- The wheels must be chocked.

The platform must be empty when the machine is being winched:

### FREEWHEEL AND WINCH

- Switch off the machine.
- Attach the winch to the machine's anchoring points, ⚠ STICKERS: ANCHORING POINT.
- Bypass the hydrostatic circuit:
  - Open the left-hand turntable cover.
  - Locate the hydrostatic pump and the 2 pressure relief valves ①.
  - Unscrew the nuts ①A. Tighten the screws ①B to the hard spot and then tighten them a half turn more.
  - Tighten the nuts ①A: tightening torque = 22 N.m
  - Close the left-hand turntable cover.
- Release the brakes:
  - Locate the 2 screws ② and the 2 screws ③ to the left and right of the rear axle.
  - Loosen the 2 locknuts ④ by about 8 mm.
  - Tighten the screws ② and ③ by hand to the hard spot.
  - Tighten the 2 screws alternately ② by a quarter turn each time until you have gone all the way round.
  - Tighten the 2 screws alternately ③ by a quarter turn each time until you have gone all the way round.
- Make sure the route is free of any obstruction.
- Remove the chocks from the wheels.
- Winch the machine slowly.
- Chock the wheels when the machine is in the desired position.

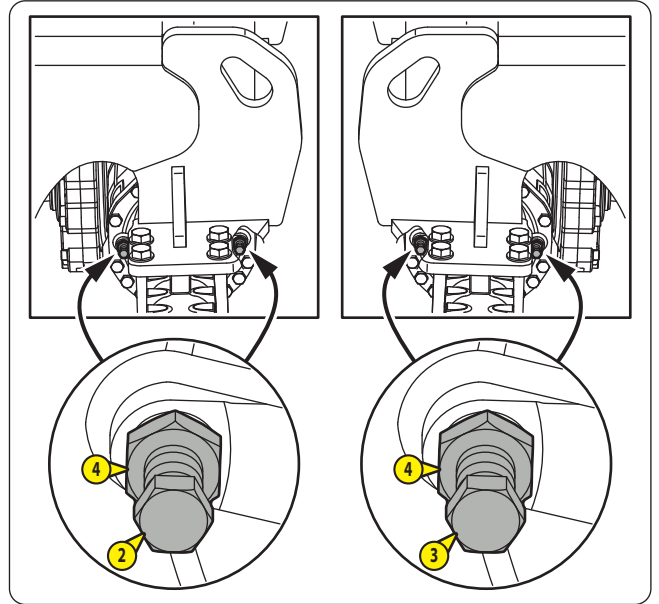
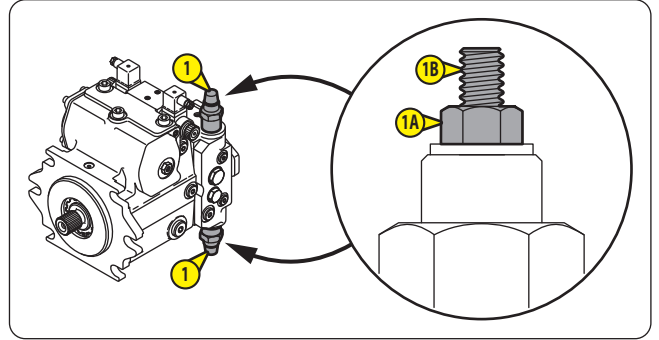

## REAPPLY THE BRAKES AND RESTORE THE HYDROSTATIC CIRCUIT

- Reapply the brakes:
  - Loosen the 2 screws alternately **2** by a quarter turn each time until you have gone all the way round.
  - Loosen the 2 screws alternately **3** by a quarter turn each time until you have gone all the way round.
  - Unscrew the 4 screws **2** and **3** completely.
  - Change the 4 seals **5**.
  - Lubricate the screws **2** and **3** with MANITOU BLACK MULTI-PURPOSE LUBRICANT (← 3 - MAINTENANCE: LUBRICANTS) and put them back in place.
  - Adjust the distance between the body of the axle and the screw heads = 34 mm ±0.5 mm.
  - Tighten the 4 locknuts **4** and check the distances between the body of the axle and the screw heads.
- Restore the hydrostatic circuit:
  - Open the left-hand turntable cover.
  - Unscrew the nuts **1A**.
  - Loosen the screws **1B** up to the mechanical stop.
  - Tighten the nuts **1A**: tightening torque = 22 N.m
  - Close the left-hand turntable cover.

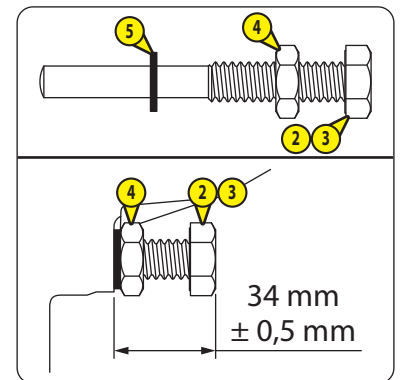
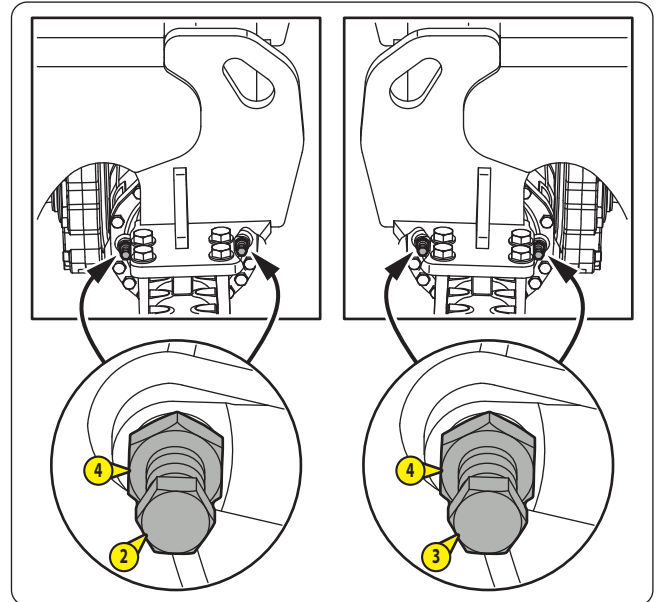

## TEST THE BRAKES

- Remove the right-hand chassis cover.
- Locate the coil **6** on the hydraulic block and disconnect it.
- Start the diesel engine.
- Try to drive the machine forward and backward.

Result:

- The machine should remain stationary.
- Reconnect the coil **6**.
- Refit the right-hand chassis cover.
- Switch off the machine.

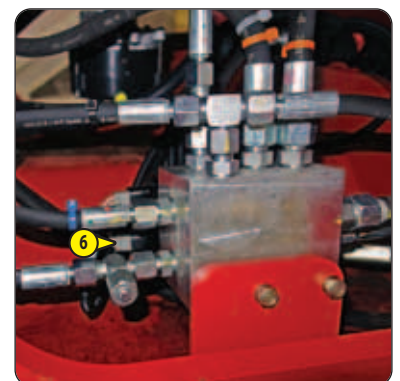
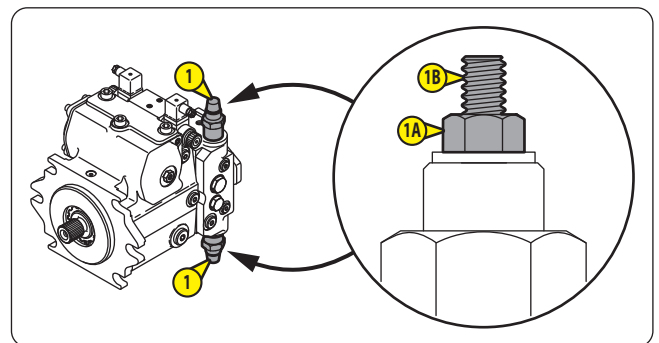

**⚠ IMPORTANT ⚠**

The surface of the departure/arrival zone must be closed, level and even.

If the departure/arrival zone is a transport vehicle:

- The transport vehicle must be parked on a level, firm surface.
- The wheels of the transport vehicle must be chocked.

Make sure that the lifting slings are solid enough to take the weight of the machine.

Make sure that the lifting capacity of the crane is sufficient to take the weight of the machine.

The turntable must be locked at 12° before lifting the machine.

Covers must be closed and locked (if applicable) while the machine is being lifted.

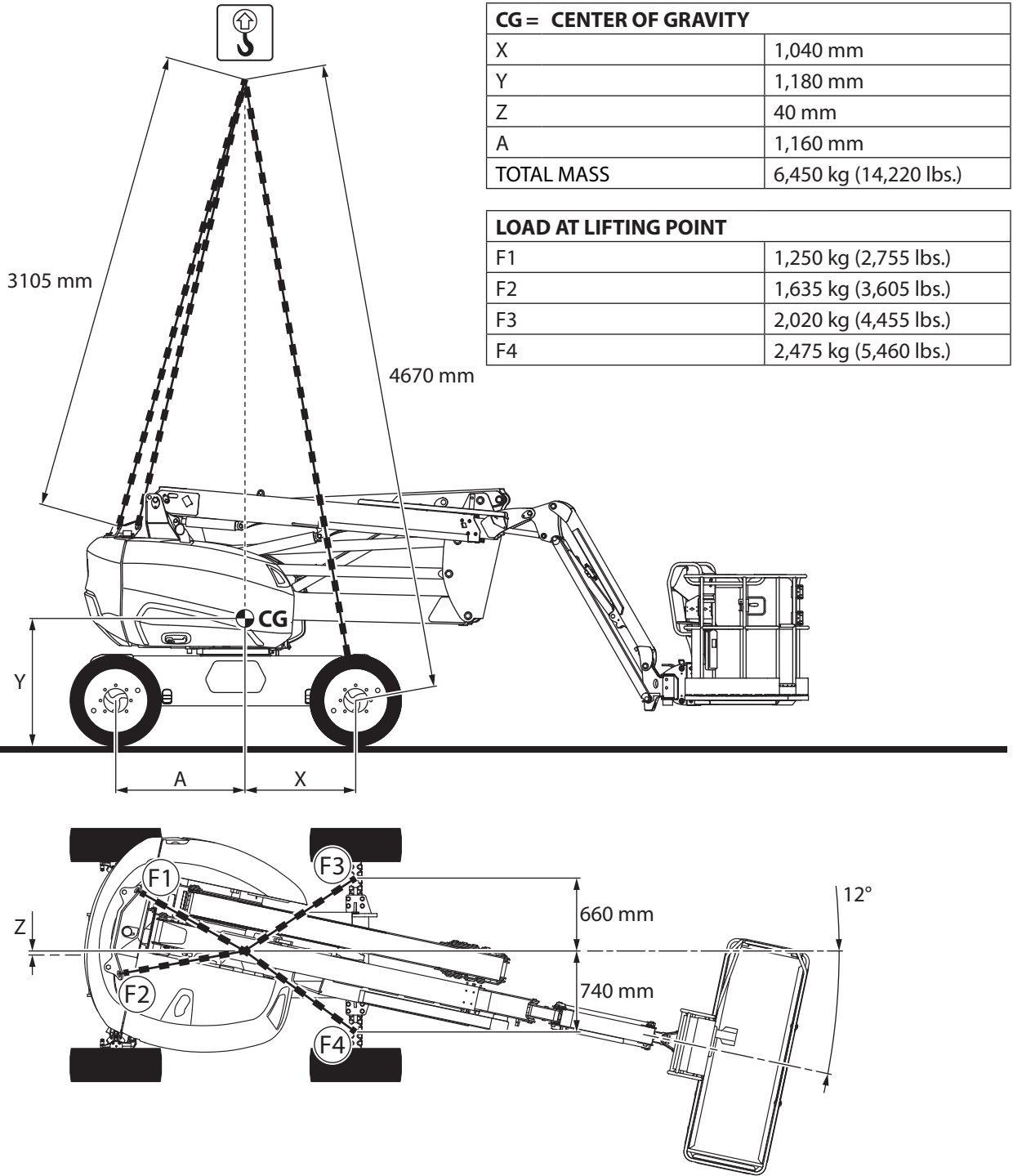

CG = CENTER OF GRAVITY	
X	1,040 mm
Y	1,180 mm
Z	40 mm
A	1,160 mm
TOTAL MASS	6,450 kg (14,220 lbs.)

LOAD AT LIFTING POINT	
F1	1,250 kg (2,755 lbs.)
F2	1,635 kg (3,605 lbs.)
F3	2,020 kg (4,455 lbs.)
F4	2,475 kg (5,460 lbs.)

- Mark out a wide safety area around the machine.
- Start the diesel engine.
- Put the machine in transport position. Put the platform in neutral position, <img alt="arrow icon" data-bbox="105 88 118 101"/> OPERATING THE MACHINE: TRANSPORT/WORKING POSITION.
- Fully lower the jib arm.
- Ensure that the turntable is unlocked, <img alt="arrow icon" data-bbox="105 121 118 134"/> SAFETY COMPONENTS: TURNTABLE LOCKING PIN.
- **A** Locate the lift lock **1**.
- **A** Remove the safety pin **2** and the lever **3**.
- **B** Put the lift lock, lever and safety pin in place.
- **B** Turn the turntable 12° to the left to align the locking pin **4** and the lift lock notch **1**.
- **C** Pull the locking pin **4** and turn it to the left.
- **C** Push it into the lift lock notch **1**.
- Switch off the machine. Remove the key.
- Attach lifting slings to the 2 lifting points on the turntable, <img alt="arrow icon" data-bbox="105 274 118 287"/> STICKERS: LIFTING POINT.
- Attach lifting slings around the rear axle as shown in the illustration on the previous page.
- Attach the lifting slings at 1 point to the crane lifting hook.
- Slowly lift the crane's lifting hook until the lifting slings are slightly taut.
- If necessary, adjust the lifting slings to prevent damage and keep the machine level.
- Ensure that there is nobody in the safety zone.
- Lift the machine slowly and move it to the arrival zone.
- Slowly lower the machine until the 4 wheels are in contact with the receiving surface.
- Lower the crane's lifting hook until the lifting slings are no longer taut.
- Detach the lifting slings.
- **C** Pull the locking pin **4**, turn it to the right and push it into position **B**.
- **B** Remove the safety pin **2** and the lever **3**.
- **A** Put the lift lock, lever and safety pin in place.
- Start the diesel engine.
- Turn the turntable to the right in neutral position, <img alt="arrow icon" data-bbox="105 506 118 519"/> OPERATING THE MACHINE: TRANSPORT/WORKING POSITION.
- Lock the turntable if the machine is loaded onto a transport vehicle, <img alt="arrow icon" data-bbox="105 539 118 552"/> SAFETY COMPONENTS: TURNTABLE LOCKING PIN.
- Switch off the machine.

Note: <img alt="arrow icon" data-bbox="105 581 118 594"/> STICKERS: LIFTING 160 ATJ.

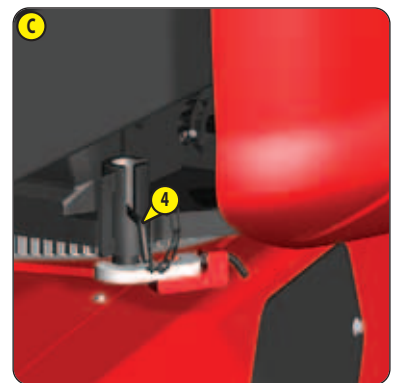
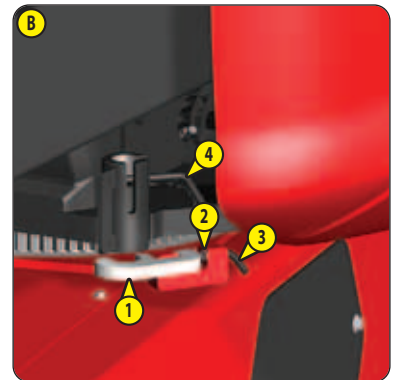
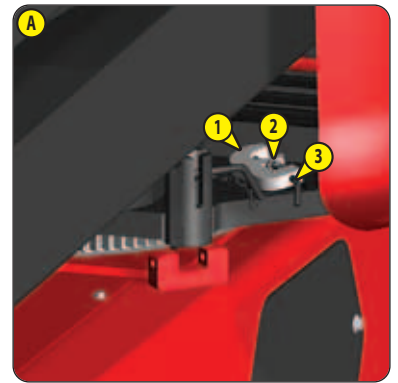

**⚠ IMPORTANT ⚠**

The surface of the departure/arrival zone must be closed, level and even.

If the departure/arrival zone is a transport vehicle:

- The transport vehicle must be parked on a level, firm surface.
- The wheels of the transport vehicle must be chocked.

Make sure that the lifting slings are solid enough to take the weight of the machine.

Make sure that the lifting capacity of the crane is sufficient to take the weight of the machine.

The turntable must be locked at 12° before lifting the machine.

Covers must be closed and locked (if applicable) while the machine is being lifted.

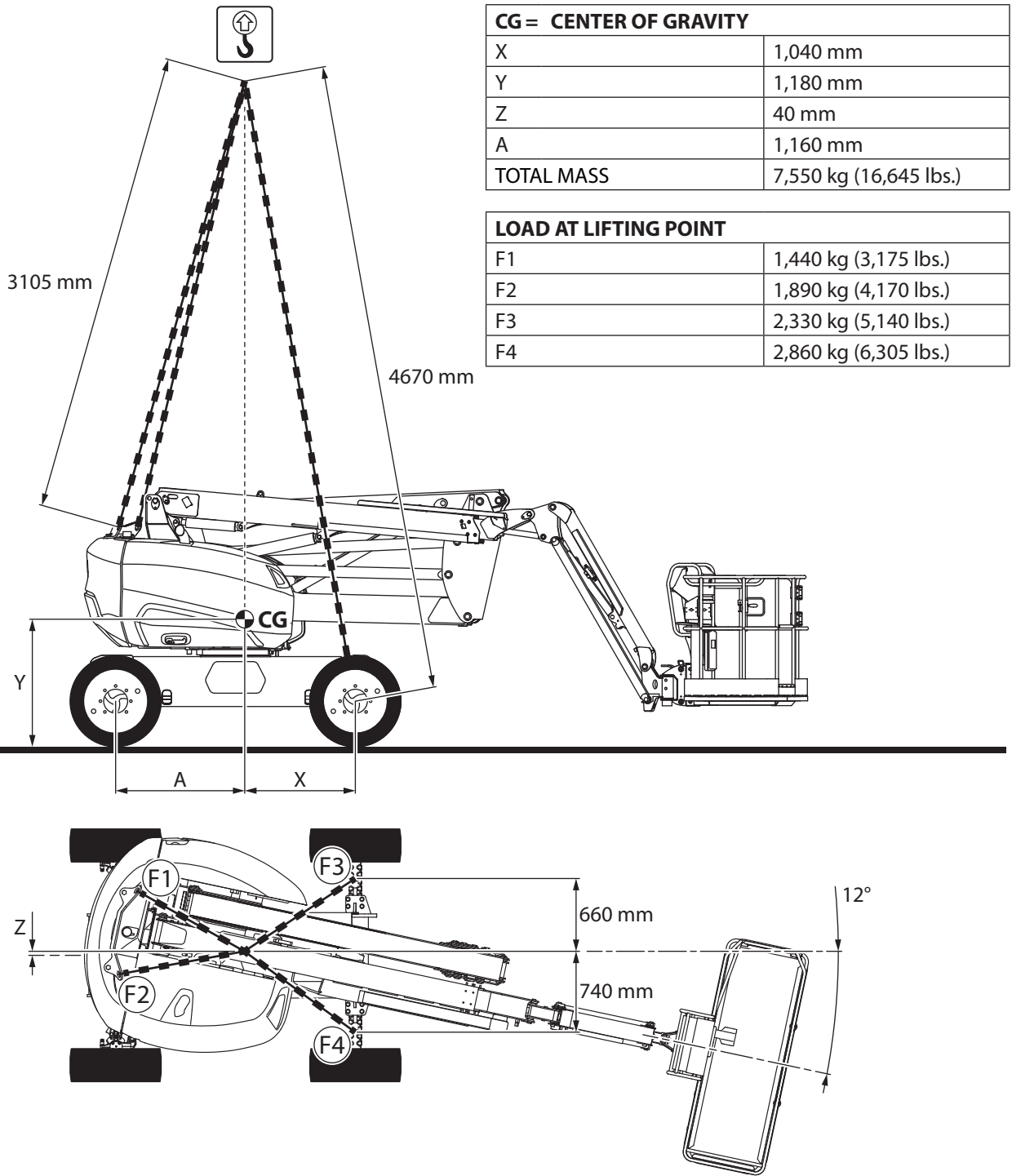

- Mark out a wide safety area around the machine.
- Start the diesel engine.
- Put the machine in transport position. Put the platform in neutral position, <img alt="arrow icon" data-bbox="105 88 118 101"/> OPERATING THE MACHINE: TRANSPORT/WORKING POSITION.
- Fully lower the jib arm.
- Ensure that the turntable is unlocked, <img alt="arrow icon" data-bbox="105 121 118 134"/> SAFETY COMPONENTS: TURNTABLE LOCKING PIN.
- **A** Locate the lift lock **1**.
- **A** Remove the safety pin **2** and the lever **3**.
- **B** Put the lift lock, lever and safety pin in place.
- **B** Turn the turntable 12° to the left to align the locking pin **4** and the lift lock notch **1**.
- **C** Pull the locking pin **4** and turn it to the left.
- **C** Push it into the lift lock notch **1**.
- Switch off the machine. Remove the key.
- Attach lifting slings to the 2 lifting points on the turntable, <img alt="arrow icon" data-bbox="105 274 118 287"/> STICKERS: LIFTING POINT.
- Attach lifting slings around the rear axle as shown in the illustration on the previous page.
- Attach the lifting slings at 1 point to the crane lifting hook.
- Slowly lift the crane's lifting hook until the lifting slings are slightly taut.
- If necessary, adjust the lifting slings to prevent damage and keep the machine level.
- Ensure that there is nobody in the safety zone.
- Lift the machine slowly and move it to the arrival zone.
- Slowly lower the machine until the 4 wheels are in contact with the receiving surface.
- Lower the crane's lifting hook until the lifting slings are no longer taut.
- Detach the lifting slings.
- **C** Pull the locking pin **4**, turn it to the right and push it into position **B**.
- **B** Remove the safety pin **2** and the lever **3**.
- **A** Put the lift lock, lever and safety pin in place.
- Start the diesel engine.
- Turn the turntable to the right in neutral position, <img alt="arrow icon" data-bbox="105 506 118 519"/> OPERATING THE MACHINE: TRANSPORT/WORKING POSITION.
- Lock the turntable if the machine is loaded onto a transport vehicle, <img alt="arrow icon" data-bbox="105 539 118 552"/> SAFETY COMPONENTS: TURNTABLE LOCKING PIN.
- Switch off the machine.

Note: <img alt="arrow icon" data-bbox="105 581 118 594"/> STICKERS: LIFTING 180 ATJ.

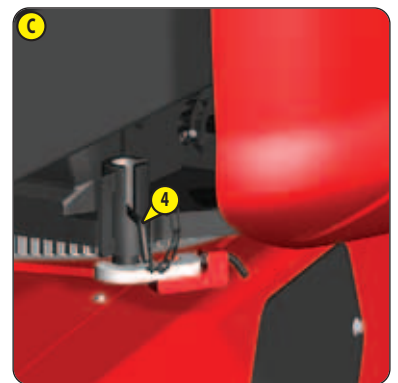
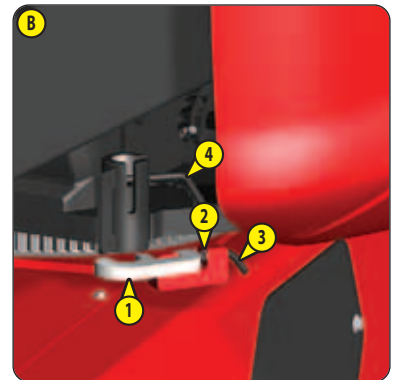
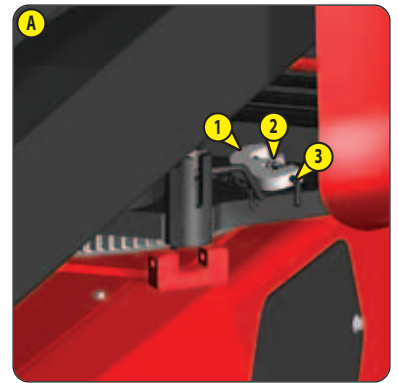



# ***3 - MAINTENANCE***

## 3 - MAINTENANCE

<b>INTRODUCTION</b>	<b>3-3</b>
<b>ORIGINAL MANITOU SPARE PARTS AND EQUIPMENT</b>	<b>3-3</b>
<b>DAILY AND MONTHLY MAINTENANCE</b>	<b>3-4</b>
<b>MANDATORY SERVICING AND PERIODIC MAINTENANCE</b>	<b>3-5</b>
<b>OCCASIONAL MAINTENANCE AND OCCASIONAL OPERATIONS</b>	<b>3-8</b>
<b>FILTER CARTRIDGES AND BELTS</b>	<b>3-9</b>
<b>LUBRICANTS, COOLANT AND FUEL</b>	<b>3-10</b>
<b>➤ DAILY MAINTENANCE</b>	<b>3-12</b>
<b>➤ MONTHLY MAINTENANCE OR EVERY 50 HOURS OF SERVICE</b>	<b>3-25</b>
<b>➤ ➊ 250H - PERIODIC MAINTENANCE - EVERY 250 HOURS OF SERVICE OR 6 MONTHS</b>	<b>3-31</b>
<b>➤ ➋ 500H - PERIODIC MAINTENANCE - EVERY 500 HOURS OF SERVICE OR 1 YEAR</b>	<b>3-40</b>
<b>➤ ➌ 1000H - PERIODIC MAINTENANCE - EVERY 1,000 HOURS OF SERVICE OR 2 YEARS</b>	<b>3-51</b>
<b>➤ ➍ 2000H - PERIODIC MAINTENANCE - EVERY 2,000 HOURS OF SERVICE OR 4 YEARS</b>	<b>3-56</b>
<b>➤ OCCASIONAL SERVICING</b>	<b>3-57</b>
<b>➤ OCCASIONAL OPERATIONS</b>	<b>3-61</b>

## INTRODUCTION

MAINTENANCE OPERATIONS REQUIRE SPECIFIC PRECAUTIONS.

### **⚠ IMPORTANT ⚠**

*Unless specific instructions are given, during maintenance operations:*

- *The machine should be switched off.*
- *The machine must be on a level surface. The wheels must be chocked.*
- *The machine should be in transport position. The turntable and the platform should be in neutral position, <img alt="arrow pointing left" data-bbox="415 158 430 173"/> 2 - DESCRIPTION: OPERATING THE MACHINE: TRANSPORT/WORKING POSITION.*
- *The jib arm must be fully lowered.*
- *The platform must be empty.*
- *The turntable must be unlocked, <img alt="arrow pointing left" data-bbox="405 215 420 230"/> 2 - DESCRIPTION: SAFETY COMPONENTS: TURNABLE LOCKING PIN.*

## ORIGINAL MANITOU SPARE PARTS AND EQUIPMENT

OUR MACHINES MUST BE SERVICED USING ORIGINAL MANITOU PARTS.

### **BY ALLOWING THE USE OF NON ORIGINAL MANITOU PARTS, YOU RISK:**

#### **⚠ IMPORTANT ⚠**

**THE USE OF COUNTERFEIT PARTS OR COMPONENTS NOT APPROVED BY THE MANUFACTURER, MEANS YOU LOSE THE BENEFIT OF THE CONTRACTUAL GUARANTEE.**

- Legally - to incur liability in the event of an accident.
- Technically, causing operating malfunctions and reducing the machine's service life.

### **BY USING ORIGINAL MANITOU PARTS FOR MAINTENANCE OPERATIONS, YOU BENEFIT FROM OUR KNOW-HOW**

Through its network, MANITOU provides the user with:

- Know-how and competence.
- The guarantee of high-quality work.
- Original replacement parts.
- Help with preventive maintenance.
- Efficient help with diagnosis.
- Improvements due to experience feedback.
- Operator training.
- Only the MANITOU network has detailed knowledge of the design of the machine and therefore the best technical ability to provide maintenance.

#### **⚠ IMPORTANT ⚠**

**ORIGINAL REPLACEMENT PARTS ARE DISTRIBUTED EXCLUSIVELY BY MANITOU AND ITS DEALER NETWORK.**

*The dealer network list is available on the MANITOU web site: [www.manitou.com](http://www.manitou.com)*

## DAILY AND MONTHLY MAINTENANCE

### **⚠ IMPORTANT ⚠**

**DAILY MAINTENANCE MUST BE CARRIED OUT BY THE OPERATOR BEFORE USING THE MACHINE.  
MONTHLY MAINTENANCE MUST BE CARRIED OUT BY THE MAINTENANCE PERSONNEL.**

#### **🔄 DAILY MAINTENANCE**

- CHECK	General inspection .....	3-12
- CHECK	Fuel level .....	3-12
- CHECK	Diesel engine oil level .....	3-13
- CHECK	Coolant level .....	3-13
- CHECK	Hydraulic oil level .....	3-14
- CHECK	Machine operation .....	3-14

#### **🔄 MONTHLY MAINTENANCE OR EVERY 50 HOURS OF SERVICE**

##### **ALSO PERFORM THE DAILY MAINTENANCE.**

- CHECK	Alternator/fan belt .....	3-25
- CHECK	Injection pipes, fuel hoses and the hose clamps .....	3-25
- CHECK	Reduction gearbox seal .....	3-25
- CHECK	Front and rear axle differential seals .....	3-26
- CHECK	Front and rear wheel reduction gear seals .....	3-26
- CLEAN	Coolant and oil radiators .....	3-26
- CLEAN	Outside air filter cartridge .....	3-27
- LUBRICATE	Axles .....	3-28
- CHECK	230 V electric power socket in the platform (OPTION) .....	3-29
- CHECK	Generator (OPTION) .....	3-30

## MANDATORY SERVICING AND PERIODIC MAINTENANCE



**MANDATORY SERVICING AND PERIODIC MAINTENANCE MUST BE CARRIED OUT BY AN APPROVED PROFESSIONAL FROM THE MANITOU NETWORK.**

### MAINTENANCE SCHEDULE

This schedule enables mandatory servicing and periodic maintenance on the machine to be kept up-to-date by reporting the total number of hours worked and the date of the service.

	⬇	⬇	OR	⬇
SCHEDULE ➡	FIRST 50 HOURS	FIRST 6 MONTHS		FIRST 500 HOURS
MANDATORY SERVICE ➡	FIRST 50 HOURS	FIRST 500 HOURS OR 6 MONTHS		FIRST 500 HOURS OR 6 MONTHS + 2
MACHINE COUNTER ➡				
DATE OF SERVICING ➡				

SCHEDULE ➡	250 H	500 H or 1 YEAR	750 H	1000 H or 2 YEARS	1250 H
PERIODIC SERVICE ➡	1	1 + 2	1	1 + 2 + 3	1
MACHINE COUNTER ➡					
DATE OF SERVICING ➡					

SCHEDULE ➡	1500 H or 3 YEARS	1750 H	2000 H or 4 YEARS	2250 H	2500 H or 5 YEARS
PERIODIC SERVICE ➡	1 + 2	1	1 + 2 + 3 + 4	1	1 + 2
MACHINE COUNTER ➡					
DATE OF SERVICING ➡					

SCHEDULE ➡	2750 H	3000 H or 6 YEARS	3250 H	3500 H or 7 YEARS	3750 H
PERIODIC SERVICE ➡	1	1 + 2 + 3	1	1 + 2	1
MACHINE COUNTER ➡					
DATE OF SERVICING ➡					

SCHEDULE ➡	4000 H or 8 YEARS	4250 H	4500 H or 9 YEARS	4750 H	5000 H or 10 YEARS
PERIODIC SERVICE ➡	1 + 2 + 3 + 4	1	1 + 2	1	1 + 2 + 3
MACHINE COUNTER ➡					
DATE OF SERVICING ➡					

SCHEDULE ➡	5250 H	5500 H or 11 YEARS	5750 H	6000 H or 12 YEARS
PERIODIC SERVICE ➡	1	1 + 2	1	1 + 2 + 3 + 4
MACHINE COUNTER ➡				
DATE OF SERVICING ➡				

## MANDATORY SERVICE - FIRST 50 HOURS

### ALSO PERFORM THE MONTHLY MAINTENANCE.

This service must be carried out in the first 50 hours of service.

- CHECK	Alternator/fan belt .....	3-25
- CHECK	Wheel nut tightening .....	3-31
- CHECK	Tightening of the fixing screws for the oscillating cylinders .....	3-31
- CHECK	Tightening of the fixing screws for the axles .....	3-32
- CHECK	Tightening of the platform fixing screws .....	3-40
- CHECK	Tightening of the platform rotation cylinder fixing screws .....	3-40
- REPLACE	Diesel engine oil .....	3-47
- REPLACE	Diesel engine oil filter .....	3-47

## MANDATORY SERVICE - FIRST 500 HOURS OR 6 MONTHS

This service must be carried out in the first 500 hours of service or within the 6 months following the start-up of the machine (whichever occurs first):

### FIRST 500 HOURS BEFORE THE FIRST 6 MONTHS

- If the machine has reached the first 500 hours of service before the first 6 months have expired, perform both the compulsory service and periodic 500-hour maintenance (  500H - PERIODIC MAINTENANCE - EVERY 500 HOURS OF SERVICE OR 1 YEAR).

### FIRST 6 MONTHS BEFORE THE FIRST 500 HOURS

- If the machine has not completed 500 hours of service in the first 6 months, carry out only the mandatory service.

- CHECK	General inspection .....	3-12
- CHECK	Machine operation .....	3-14
- CHECK	Alternator/fan belt .....	3-25
- CHECK	Injection pipes, fuel hoses and the hose clamps .....	3-25
- CHECK	Reduction gearbox seal .....	3-25
- CHECK	Front and rear axle differential seals .....	3-26
- CHECK	Front and rear wheel reduction gear seals .....	3-26
- CLEAN	Coolant and oil radiators .....	3-26
- CLEAN	Outside air filter cartridge .....	3-27
- LUBRICATE	Axles .....	3-28
- CHECK	230 V electric power socket in the platform (OPTION) .....	3-29
- CHECK	Generator (OPTION) .....	3-30
- CHECK	Wheel nut tightening .....	3-31
- CHECK	Tightening of the fixing screws for the oscillating cylinders .....	3-31
- CHECK	Tightening of the transmission shaft fixing screws .....	3-32
- CHECK	Tightening of the fixing screws for the axles .....	3-32
- CHECK	Locking of the front axle oscillating cylinders .....	3-33
- CHECK	Overload system .....	3-34
- CHECK	Brakes .....	3-35
- CHECK	Turntable rotation motor oil level .....	3-36
- CHECK	Emergency controls .....	3-36
- LUBRICATE	Shafts, hubs and cylinder rings .....	3-37
- GREASE	Telescopic arm .....	3-38
- LUBRICATE	Crown gear .....	3-38
- CHECK	Tightening of 12 V electrical connections .....	3-39
- CHECK	Tilt sensor .....	3-40
- CHECK	Tightening of the platform fixing screws .....	3-40
- CHECK	Tightening of the platform rotation cylinder fixing screws .....	3-40
- CHECK	Chocking of the telescopic arm 160 ATJ .....	3-41
- CHECK	Chocking of the telescopic arm 180 ATJ .....	3-42
- CHECK	Tightening of the fixing screws for the crown gear .....	3-43
- CHECK	Tightening of the fixing screws on the turntable rotation motor .....	3-43
- CHECK	Counterweight fixing screw tightening .....	3-44
- CHECK	Lifting support fixing screw tightening .....	3-44
- CHECK	Hydraulic hoses .....	3-44

- CHECK	Diesel engine silent blocks *	3-55
- CHECK	Diesel engine speeds *	3-55
- CHECK	Valve lash *	3-55
- CHECK	Injectors *	3-55
- CHECK	Hydrostatic transmission circuit pressure *	3-55
- CHECK	Clearance of slewing ring gear *	3-55
- CHECK	Speeds of hydraulic movements *	3-55
- CHECK	Condition of cylinders *	3-55
- CHECK	Condition of electric wiring *	3-55

*\* Consult your dealer.*

## ➔ ① 250H - PERIODIC MAINTENANCE - EVERY 250 HOURS OF SERVICE OR 6 MONTHS

### ALSO PERFORM THE DAILY MAINTENANCE.

- CHECK	Alternator/fan belt	3-31
- CHECK	Injection pipes, fuel hoses and the hose clamps	3-31
- CHECK	Reduction gearbox seal	3-31
- CHECK	Front and rear axle differential seals	3-31
- CHECK	Front and rear wheel reduction gear seals	3-31
- CHECK	230 V electric power socket in the platform (OPTION)	3-31
- CHECK	Electric generator (OPTION)	3-31
- CHECK	Wheel nut tightening	3-31
- CHECK	Tightening of the fixing screws for the oscillating cylinders	3-31
- CHECK	Tightening of the transmission shaft fixing screws	3-32
- CHECK	Tightening of the fixing screws for the axles	3-32
- CHECK	Locking of the front axle oscillating cylinders	3-33
- CHECK	Overload system	3-34
- CHECK	Brakes	3-35
- CHECK	Turntable rotation motor oil level	3-36
- CHECK	Emergency controls	3-36
- LUBRICATE	Shafts, hubs and cylinder rings	3-37
- GREASE	Telescopic arm	3-38
- LUBRICATE	Crown gear	3-38
- CHECK	Tightening of 12 V electrical connections	3-39
- RESET	Maintenance warning	3-39

## ➔ ② 500H - PERIODIC MAINTENANCE - EVERY 500 HOURS OF SERVICE OR 1 YEAR

### ALSO PERFORM THE DAILY SERVICE AND THE PERIODIC SERVICE AT 250 HOURS OF SERVICE.

- CHECK	Tilt sensor	3-40
- CHECK	Tightening of the platform fixing screws	3-40
- CHECK	Tightening of the platform rotation cylinder fixing screws	3-40
- CHECK	Chocking of the telescopic arm 160 ATJ	3-41
- CHECK	Chocking of the telescopic arm 180 ATJ	3-42
- CHECK	Tightening of the fixing screws for the crown gear	3-43
- CHECK	Tightening of the fixing screws on the turntable rotation motor	3-43
- CHECK	Counterweight fixing screw tightening	3-44
- CHECK	Lifting support fixing screw tightening	3-44
- CHECK	Hydraulic hoses	3-44
- REPLACE	Alternator/fan belt	3-45
- REPLACE	Fuel pre-filter	3-45
- REPLACE	Fuel filter cartridge	3-46
- REPLACE	Diesel engine oil	3-47
- REPLACE	Diesel engine oil filter	3-47
- REPLACE	Outside air filter cartridge	3-48
- REPLACE	Turntable rotation motor oil	3-49
- REPLACE	Hydraulic pressure filter cartridge	3-49
- REPLACE	Hydrostatic transmission filter cartridge	3-50
- RESET	Maintenance warning	3-50

### ➔ ③ 1000H - PERIODIC MAINTENANCE - EVERY 1,000 HOURS OF SERVICE OR 2 YEARS

**ALSO PERFORM THE DAILY SERVICE AND THE PERIODIC SERVICES AT 250 HOURS AND 500 HOURS OF SERVICE.**

- CLEAN	Fuel tank .....	3-51
- REPLACE	Inside air filter cartridge .....	3-51
- REPLACE	Coolant .....	3-52
- REPLACE	Reduction gearbox oil .....	3-52
- REPLACE	Front and rear axle differential oil .....	3-53
- REPLACE	Front and rear wheel reduction gear oil .....	3-53
- REPLACE	Hydraulic oil .....	3-54
- CLEAN	Filling filter and suction strainer .....	3-54
- CHECK	Diesel engine silent blocks * .....	3-55
- CHECK	Diesel engine speeds * .....	3-55
- CHECK	Valve lash * .....	3-55
- CHECK	Injectors * .....	3-55
- CHECK	Hydrostatic transmission circuit pressure * .....	3-55
- CHECK	Clearance of slewing ring gear * .....	3-55
- CHECK	Speeds of hydraulic movements * .....	3-55
- CHECK	Condition of cylinders * .....	3-55
- CHECK	Condition of electric wiring * .....	3-55
- REPLACE	Air intake line and air suction hose * .....	3-55
- REPLACE	Hoses and hose clamps for the coolant radiator * .....	3-55
- REPLACE	Injection pipes, fuel hoses and the hose clamps * .....	3-55
- RESET	Maintenance warning .....	3-55

**\* Consult your dealer.**

### ➔ ④ 2000H - PERIODIC MAINTENANCE - EVERY 2,000 HOURS OF SERVICE OR 4 YEARS

**ALSO PERFORM THE DAILY SERVICE AND THE PERIODIC SERVICES AT 250 HOURS, 500 HOURS AND 1,000 HOURS OF SERVICE.**

- CHECK	Coolant and oil radiators * .....	3-56
- CHECK	Water pump and thermostat * .....	3-56
- CHECK	Injection pump * .....	3-56
- CHECK	Alternator and starter * .....	3-56
- CHECK	Hydraulic circuit pressures * .....	3-56
- RESET	Maintenance warning .....	3-56

**\* Consult your dealer.**

## OCCASIONAL MAINTENANCE AND OCCASIONAL OPERATIONS



**OCCASIONAL MAINTENANCE AND OCCASIONAL OPERATIONS MUST BE PERFORMED BY MAINTENANCE PERSONNEL OR AN APPROVED PROFESSIONAL FROM THE MANITOU NETWORK.**

### ➔ OCCASIONAL SERVICING

- REPLACE	Wheels .....	3-57
- REPLACE	Fuses/relays .....	3-58
- BLEED	Fuel supply circuit .....	3-60

### ➔ OCCASIONAL OPERATIONS

- USE	Safety strut .....	3-61
-------	--------------------	------

## FILTER CARTRIDGES AND BELTS

### ➔ ② 500H - PERIODIC MAINTENANCE - EVERY 500 HOURS OF SERVICE OR 1 YEAR



DIESEL ENGINE OIL FILTER  
Part No.: 894022



OUTSIDE AIR FILTER CARTRIDGE  
Part No.: 942077



ALTERNATOR/FAN BELT  
Part No.: 959614

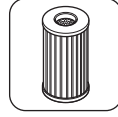

FUEL FILTER CARTRIDGE  
Part No.: 781909



FUEL PRE-FILTER  
Part No.: 734146

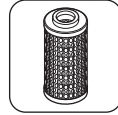

HYDRAULIC PRESSURE FILTER CARTRIDGE  
Part No.: 518251



HYDROSTATIC TRANSMISSION FILTER  
CARTRIDGE  
Part No.: 518251

### ➔ ③ 1000H - PERIODIC MAINTENANCE - EVERY 1,000 HOURS OF SERVICE OR 2 YEARS

*ALSO ADD FILTER CARTRIDGES AND BELTS FOR PERIODIC MAINTENANCE AFTER 500 HOURS OF SERVICE.*



INSIDE AIR FILTER CARTRIDGE  
Part No.: 942078

### ➔ OTHER FILTER CARTRIDGES



HYDRAULIC OIL TANK FILLER CAP/FILTER  
Part No.: 832750

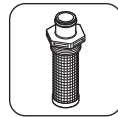

HYDRAULIC OIL TANK SUCTION STRAINER  
Part No.: 749589

## LUBRICANTS, COOLANT AND FUEL

### ⚠ IMPORTANT ⚠

USE THE RECOMMENDED LUBRICANTS, COOLANT AND FUEL:

- For topping up, oils may not be miscible.
- For oil changes, MANITOU oils are perfectly appropriate.

### ANALYSIS OF OILS

If a service or maintenance contract has been set up with the dealer, an analysis of the diesel engine oil and the hydraulic oil is requested depending on the rate of use.

### (\*) SPECIFICATIONS OF THE RECOMMENDED FUEL

Use a high-quality fuel to obtain optimal performance of the diesel engine.

- EN590 diesel fuel (sulfur content < 10 ppm).
- ASTM D975 diesel fuel (sulfur content < 15 ppm).

NB: Biodiesel fuel with concentrations up to 7% is allowed.

### RECOMMENDATION

DIESEL ENGINE		
DESCRIPTION	CAPACITY	RECOMMENDATION
		-40 °C -30 °C -20 °C -10 °C 0 °C 10 °C 20 °C 30 °C 40 °C 50 °C
DIESEL ENGINE OIL	4.5 L	10W30
		10W40
		MANITOU OIL 15W40 API CH4
COOLING CIRCUIT	4.3 L	COOLANT -35 °C
FUEL TANK	52 L	GNR HP DIESEL *

HYDRAULICS		
DESCRIPTION	CAPACITY	RECOMMENDATION
		-40 °C -30 °C -20 °C -10 °C 0 °C 10 °C 20 °C 30 °C 40 °C 50 °C
HYDRAULIC OIL TANK	54 L	ISO VG 100
		ISO VG 68
		MANITOU HYDRAULIC OIL ISO VG 46
		ISO VG 37
		ISO VG 32

TRANSMISSION		
DESCRIPTION	CAPACITY	RECOMMENDATION
		-40 °C -30 °C -20 °C -10 °C 0 °C 10 °C 20 °C 30 °C 40 °C 50 °C
REDUCTION GEAR BOX	0.8 L	MANITOU MECHANICAL TRANSMISSION OIL SAE80W90

REAR AXLE		
DESCRIPTION	CAPACITY	RECOMMENDATION
		-40 °C -30 °C -20 °C -10 °C 0 °C 10 °C 20 °C 30 °C 40 °C 50 °C
DIFFERENTIAL	4.8 L	SPECIAL MANITOU OIL FOR IMMersed BRAKES
WHEEL GEAR REDUCER	2 x 0.8 L	MANITOU MECHANICAL TRANSMISSION OIL SAE80W90
WHEEL GEAR REDUCER PIVOTS		MANITOU BLACK MULTI-PURPOSE LUBRICANT

FRONT AXLE											
DESCRIPTION	CAPACITY	RECOMMENDATION									
		-40 °C	-30 °C	-20 °C	-10 °C	0 °C	10 °C	20 °C	30 °C	40 °C	50 °C
DIFFERENTIAL	4 L	SPECIAL MANITOU OIL FOR IMMersed BRAKES									
WHEEL GEAR REDUCER	2 x 0.8 L	MANITOU MECHANICAL TRANSMISSION OIL SAE80W90									
WHEEL GEAR REDUCER PIVOTS		MANITOU BLACK MULTI-PURPOSE LUBRICANT									
OSCILLATION BEARINGS		MANITOU BLACK MULTI-PURPOSE LUBRICANT									

LIFTING STRUCTURE											
DESCRIPTION	CAPACITY	RECOMMENDATION									
		-40 °C	-30 °C	-20 °C	-10 °C	0 °C	10 °C	20 °C	30 °C	40 °C	50 °C
GENERAL GREASING		MANITOU BLACK MULTI-PURPOSE LUBRICANT									
GREASING THE TELESCOPIC ARM		MANITOU BLACK MULTI-PURPOSE LUBRICANT									
CROWN GEAR BEARINGS		MANITOU BLACK MULTI-PURPOSE LUBRICANT									
CROWN GEAR TEETH		MANITOU MULTI-PURPOSE EXTREME PRESSURE LUBRICANT									
TURNTABLE ROTATION MOTOR	0.85 L	MANITOU MECHANICAL TRANSMISSION OIL SAE80W90									

## PACKAGING

OIL						
PRODUCT	PACKAGING / PART NO.					
	1 LITER	2 LITERS	5 LITERS	20 LITERS	55 LITERS	209 LITERS
- MANITOU OIL 15W40 API CH4			661706	582357	582358	582359
- MANITOU HYDRAULIC OIL ISO VG 46			545500	582297	546108	546109
- SPECIAL MANITOU OIL FOR IMMersed BRAKES			545976	582391		894257
- MANITOU MECHANICAL TRANSMISSION OIL SAE80W90		499237	720184	546330	546221	546220

GREASE						
PRODUCT	PACKAGING / PART NO.					
	400 ML	400 GR	1 KG	5 KG	20 KG	50 KG
- MANITOU MULTI-PURPOSE EXTREME PRESSURE LUBRICANT	947765					
- MANITOU BLACK MULTI-PURPOSE LUBRICANT		947766	161590			499235

LIQUID						
PRODUCT	PACKAGING / PART NO.					
	1 LITER	2 LITERS	5 LITERS	20 LITERS	55 LITERS	210 LITERS
- COOLANT -35 °C			894967	894968		894969

### CHECK

### General inspection

#### ⚠ IMPORTANT ⚠

*Consult maintenance personnel if there is doubt about the condition of the machine.*

Note: the turntable covers must be open and the battery cover ① must be removed to carry out the general inspection of the machine. They must be put back in place and closed once finished.

The operator must perform a visual and physical inspection of the machine:

- Check that the operator's manual is clean and complete.
- Check the stickers and make sure they are all present, clean and legible, ☞ 2 - DESCRIPTION: STICKERS.
- Check for the absence of leaks: fuel, diesel engine oil, coolant, battery fluid, hydraulic oil, lubricants, etc.
- Check the condition of the structure: absence of impacts, damage, cracked welding, corrosion, excessive mechanical play, wear, etc.
- Check the condition of the platform: structure, floor, sliding mid rails, gate, harness attachment points, etc.
- Check the condition of the hydraulic components: pumps, distributors, valves, cylinders, hoses, etc.
- Check the condition of the mechanical components: wheels, tires, tie rods, crown gear, shafts, etc.
- Check the condition of the electrical components: control panels, foot switch, control handles, switches, buttons, indicator lights, batteries, fuses, cables, harnesses, rotating beacon light, etc.
- Check the condition of covers, handles, locks, plugs, etc.
- Check if any parts are missing or loose: screws, nuts, pins, etc.
- Check that no parts are missing or have had unauthorized modifications.
- Check the general cleanliness of the machine: platform floor, compartments, etc.



### CHECK

### Fuel level

#### ⚠ IMPORTANT ⚠

*No flames or sparks. Do not smoke during this inspection.*

*Never add fuel if the diesel engine has been started.*

- Switch on the machine.
- Check the fuel level displayed on the ground level display screen.
- Make sure that the ground level display screen is working correctly and that all the information is visible.
- If the fuel level is low:
  - Remove the cap from the tank ①.
  - Add fuel until the maximum level is reached, ☞ LUBRICANTS, COOLANT AND FUEL.
  - Refit the tank cap.
- If the fuel level is correct:
  - Ensure that the tank cap ① is correctly closed.
- Switch off the machine.



**CHECK**

**Diesel engine oil level**

- Open the left-hand turntable cover.
- Remove the dipstick ①, clean it with a clean cloth and reinsert.
- Remove the dipstick. The level is correct when the oil is between the 2 marks A and B.
- If the level is low:
  - Put the dipstick back in place.
  - Remove the filler plug ②.
  - Add diesel engine oil, <math>\leq</math> LUBRICANTS, COOLANT AND FUEL.
  - Refit the filler cap.
  - Wait 5 minutes for the oil to settle in the crankcase.
  - Remove the dipstick, clean it with a clean cloth and reinsert.
  - Remove the dipstick. The level is correct when the oil is between the 2 marks A and B.
  - Put the dipstick back in place.
- If the level is correct:
  - Put the dipstick back in place.
  - Ensure that the filler cap ② is correctly closed.

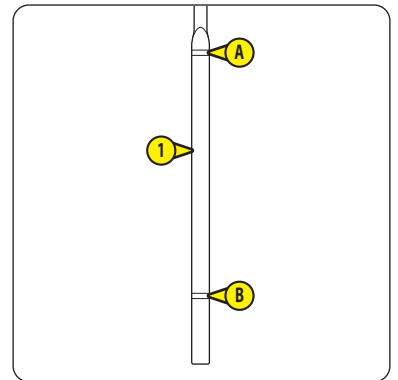
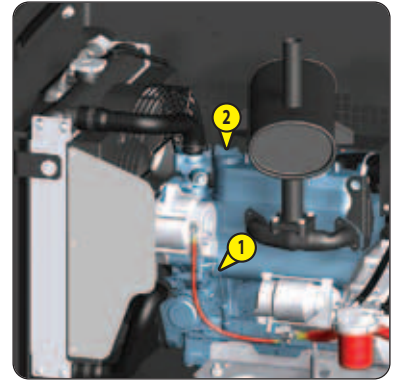

**CHECK**

**Coolant level**

**⚠ IMPORTANT ⚠**

*Wait until the diesel engine cools if it has been running for a while.  
Do not remove the radiator cap until the diesel engine is completely cooled.*

- Note: the left-hand turntable cover is open.
- Remove the radiator plug ①. The level is correct when the coolant reaches the top of the filling hole.
  - If the level is low, add coolant until the correct level is reached, <math>\leq</math> LUBRICANTS, COOLANT AND FUEL.
  - Refit the radiator cap.

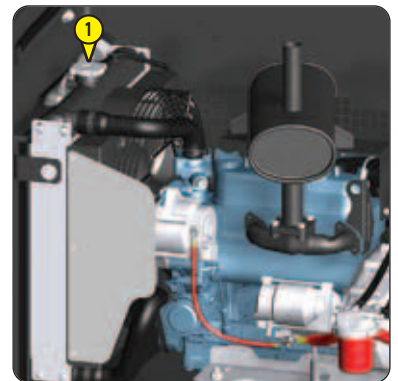

**⚠ IMPORTANT ⚠**

*The machine must be in transport position with the jib arm lowered completely.  
There can be a difference in level between hot and cold oil. It is recommended the level is checked again when the hydraulic oil is hot.  
Clean the oil can before adding oil to the hydraulic oil tank.  
Use a clean funnel to add oil to the hydraulic oil tank.*

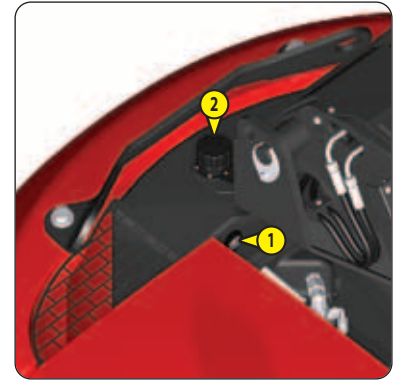

Note: the illustration shows a 180 ATJ.

- Locate the level indicator **1**. The level is correct when the oil reaches the red dot on the level indicator.
- If the level is low:
  - Remove the cap from the tank **2**
  - Add hydraulic oil until the correct level is reached, <img alt="oil can icon" data-bbox="245 238 265 253"/> LUBRICANTS, COOLANT AND FUEL.
  - Refit the tank cap.
- If the level is correct:
  - Ensure that the tank cap **2** is correctly closed.

**⚠ IMPORTANT ⚠**

<img alt="oil can icon" data-bbox="250 423 270 438"/> **2 - DESCRIPTION** for more information on the control panels on the ground and in the platform.  
*Select a test area on a firm, level surface that is free of any obstacles.  
Look around and above you when maneuvering the machine.  
Pay particular attention to electric lines and any object that may be within the machine's working area.  
Identify and shut the machine down if a malfunction is detected.*

**GROUND LEVEL CONTROL PANEL**

Note:

- Permanent orange rotating beacon light activated: the orange rotating beacon light must come on when the machine is powered up.
- Permanent orange rotating beacon light deactivated: the orange rotating beacon light must come on when the machine's functions are activated.
- All movements alarm option activated: the horn sounds intermittently when the machine functions are activated.

**POWERING ON AND STARTING THE DIESEL ENGINE AND EMERGENCY STOP**

Note: the battery cut-off (option) is in the OFF position. The ignition key is in the OFF position .

Note: the machine is in transport position. The turntable and the platform are in neutral position. The jib arm is completely lowered.

- Ensure that the emergency stop buttons on the ground level and platform control panels are in the ON position.
- Battery cut-off option: turn the battery cut-off to the ON position.

- Turn the ignition switch to the ON position .

Result:

- The ground level display screen must come on and the power-up cycle and then the preheat page must be displayed.
- The audible alarm should sound once.
- Secondary protection system option SPS: the flashing light SPS must flash several times and then go out.

**Continuation: see next page.**

- If the outside temperature is above -10 °C:

- Wait for the preheat cycle to finish.
- Press and hold down the start button.

Result:

- The diesel engine should start.
- Release the start button.

- If the outside temperature is below -10 °C:

- Wait for the preheat cycle to finish.
- Press and release the start mode button.
- Press and hold down the start button.

Result:

- The diesel engine should start and run at high speed.
- Release the start button.
- Wait for between 30 and 60 seconds without using the machine's functions.
- Raise the main arm for 3 seconds.

Result:

- The diesel engine must idle.
- Fully lower the main arm.

- Press the emergency stop button.

Result:

- The emergency stop button should be pushed down in the OFF position.
- The diesel engine should stop.
- The ground level display screen should turn off.

- Pull the emergency stop button or turn it clockwise and release it.

Result:

- The emergency stop button should be in the ON position.
- The ground level display screen must come on and the power-up cycle and then the preheat page must be displayed.
- The audible alarm should sound once.
- Secondary protection system option SPS: the flashing light SPS must flash several times and then go out.

- Wait until the preheat cycle has finished and start the diesel engine.

## MACHINE FUNCTIONS

### **⚠ IMPORTANT ⚠**

*During this test, turn the turntable by a small angle to avoid injury.*

Note: the diesel engine has been started. The machine is in transport position. The turntable and the platform are in neutral position. The jib arm is completely lowered.

- Do not touch the activation switch. Try to activate all the machine's functions one by one.

Result:

- It should not be possible to activate any of the functions.

- Push and hold the activation switch to the right  (ground level controls position).
- Activate all the machine's functions one by one. Check that all the movements are complete up to the mechanical stops.

Result:

- It should be possible to activate all the functions.
- All the movements must operate correctly and smoothly.
- All the movements must be complete up to the mechanical stops.
- Place the machine in transport position. Put the turntable in neutral position. Level the platform/jib arm. Fully lower the jib arm.
- Release the activation switch.

## OVERLOAD WARNING

Note: the diesel engine has been started. The machine is in transport position. The turntable and the platform are in neutral position. The jib arm is completely lowered.

- Place an evenly distributed load in the platform = between 253 kg and 283 kg.

Result:

- An alert page must be displayed on the ground level display screen.
- The audible alarm should sound continuously.

- Try to activate all the machine's functions one by one.

Result:

- It should not be possible to activate any of the functions.

- Remove between 23 kg and 53 kg to obtain a load of 230 kg in the platform.

Result:

- The alert page should no longer be displayed.
- The audible alarm should stop.

- Activate all the machine's functions one by one.

Result:

- It should be possible to activate all the functions.

- Place the machine in transport position. Put the turntable in neutral position. Level the platform/jib arm. Fully lower the jib arm.

## PLATFORM CONTROL PANEL

Note:

- Permanent orange rotating beacon light activated: the orange rotating beacon light must come on when the machine is powered up.
- Permanent orange rotating beacon light option deactivated: the orange rotating beacon light must come on when the machine functions are activated and when driving/steering the machine.
- All movements alarm option activated: the horn must sound intermittently when the machine functions are activated and when driving/steering the machine.
- Driving/steering option activated: the horn sounds intermittently when driving/steering the machine.

### **OVERLOAD WARNING**

Note: the diesel engine has been started. The machine is in transport position. The turntable and the platform are in neutral position. The jib arm is completely lowered.

Note: a load of 230 kg is in the platform.

- Get into the platform.

Result:

- The overload indicator light should flash.
- The audible alarm should sound continuously.

- Try to activate all the machine's functions one by one.

Result:

- It should not be possible to activate any of the functions.

- Get out of the platform.

Result:

- The overload indicator light should go out.
- The audible alarm should stop.

- Remove the whole load from the platform.

### **STARTING THE DIESEL ENGINE AND EMERGENCY STOP**

Note: the diesel engine has been started. The machine is in transport position. The turntable and the platform are in neutral position. The jib arm is completely lowered.

- Press the emergency stop button.

Result:

- The emergency stop button should be pushed down in the OFF position.
- The diesel engine should stop.

- Pull the emergency stop button or turn it clockwise and release it.

Result:

- The emergency stop button should be in the ON position.
- The preheat indicator light should light up.
- The audible alarm should sound once.
- Secondary protection system option SPS: the flashing light SPS must flash several times and then go out.

- Wait until the preheat cycle has finished and start the diesel engine.

Result:

- The diesel engine should start.

- Raise the jib arm, at the same time pressing the emergency stop button.

- Result:

- The emergency stop button should be pressed down in the OFF position.
- The jib arm should stop.

- Pull the emergency stop button or turn it clockwise and release it to put it in the ON position.

- Wait until the preheat cycle has finished and start the diesel engine.

- Fully lower the jib arm.

## HORN

Note: the diesel engine has been started. The machine is in transport position. The turntable and the platform are in neutral position. The jib arm is completely lowered.

- Press and release the horn button.

Result:

- The horn should sound.

## PLATFORM/JIB ARM TILT



*During this test, tilt the platform up and down slightly to avoid injury.*

Note: the diesel engine has been started. The machine is in transport position. The turntable and the platform are in neutral position. The jib arm is completely lowered.

- Do not touch the foot switch. Try to tilt the platform/jib arm up and down.

Result:

- It should not be possible to activate any of the functions.
- Press and hold down the foot switch.
- Raise the jib arm slightly.
- Tilt the platform/jib arm up and down slightly.

Result:

- It should be possible to activate the functions.
- Extend the telescopic arm for 3 seconds.

Result:

- It should be possible to activate the function.
- Try to tilt the platform/jib arm up and down.

Result:

- It should not be possible to activate the functions.
- Fully retract the telescopic arm. Level the platform/jib arm. Fully lower the jib arm.
- Release the foot switch.

## MACHINE FUNCTIONS (APART FROM PLATFORM/JIB ARM TILT)

Note: the diesel engine has been started. The machine is in transport position. The turntable and the platform are in neutral position. The jib arm is completely lowered.

Note: do not drive or steer the machine during this test.

- Do not touch the foot switch. Try to activate all the machine's functions one by one.

Result:

- It should not be possible to activate any of the functions.
- Press and hold down the foot switch.
- Activate all the machine's functions one by one. Check that all the movements are complete up to the mechanical stops.

Result:

- It should be possible to activate all the functions.
- All the movements must operate correctly and smoothly.
- All the movements must be complete up to the mechanical stops.
- Place the machine in transport position. Put the turntable in neutral position. Fully lower the jib arm.
- Release the foot switch.

## DRIVING/STEERING/BRAKING FUNCTIONS AND DRIVING SPEED SELECTION

Note: the diesel engine has been started. The machine is in transport position. The turntable and the platform are in neutral position. The jib arm is completely lowered.

Note: the 2 wheel alignment indicator lights should be lit.

- Select 2 wheel steer mode .
- Do not touch the foot switch, do not touch the driving/steering control handle trigger. Try to drive and steer the machine.
- Do not touch the foot switch, press and hold down the driving/steering control handle trigger. Try to drive and steer the machine.
- Press and hold down the foot switch. Do not touch the driving/steering control handle trigger. Try to drive and steer the machine.

Result:

- It should not be possible to activate the functions.

- Select hare speed .
- Raise the jib arm slightly for better visibility.
- Press and hold down the foot switch. Press and hold down the driving/steering control handle trigger.
- Drive the machine forward and brake. Assess and remember the machine's braking distance.
- Drive the machine forward, test the steering and brake.
- Reverse the machine for a short distance and brake.

Result:

- It should not be possible to activate the driving/steering functions.
- Driving and steering should function properly and smoothly.
- The brakes should function properly.
- The driving speed must be hare speed .

- Select tortoise speed .
- Drive the machine forward and brake. Assess and remember the machine's braking distance.
- Drive the machine forward, test the steering and brake.
- Reverse the machine for a short distance and brake.

Result:

- It should not be possible to activate the driving/steering functions.
- Driving and steering should function properly and smoothly.
- The brakes should function properly.
- The driving speed must be tortoise speed .

- Align the front wheels.



Result:

- The front wheel alignment indicator light should be lit.
- Release the foot switch.

## STEERING MODE

Note: the diesel engine has been started. The machine is in transport position. The turntable and the platform are in neutral position. The jib arm is slightly raised.

Note: tortoise speed  is selected. 2 wheel steer mode  is selected. The front and rear wheels are aligned.

- Select 4 wheel steer mode .
- Select hare speed .
- Steer to the left or right, drive the machine forward for a short distance and brake.
- Reverse the machine for a short distance and brake.

Result:

- The driving speed must be ramp speed .
- Steering mode selection should function properly.
- Align the front and rear wheels.

Result:

- The 2 wheel alignment indicator lights should be lit.
- Select crab mode .
- Steer to the left or right, drive the machine forward for a short distance and brake.

Result:

- The driving speed must be hare speed .
- Steering mode selection should function properly.
- Reverse the machine for a short distance and brake.

Result:

- The driving speed must be ramp speed .
- Align the front and rear wheels.

Result:

- The two wheel alignment indicator lights should come on.
- Select 2 wheel steer mode .

## WORKING POSITION SPEED

Note: the diesel engine has been started. The machine is in transport position. The turntable and the platform are in neutral position. The jib arm is slightly raised.

Note: hare speed  is selected. 2 wheel steer mode  is selected. The front and rear wheels are aligned.

- Select tortoise speed .
- Drive the machine forward for a short distance and brake. Assess and remember the speed of the machine.
- Raise the main arm for 3 seconds.
- Drive the machine forward for a short distance and brake.

Result:

- The driving speed must be working speed.
- Fully lower the main arm.
- Drive the machine forward for a short distance and brake.

Result:

- The driving speed must be tortoise speed .
- Raise the secondary arm for 3 seconds.
- Drive the machine forward for a short distance and brake.

Result:

- The driving speed must be working speed.
- Fully lower the secondary arm.
- Drive the machine forward for a short distance and brake.

Result:

- The driving speed must be tortoise speed .
- Extend the telescopic arm for 3 seconds.
- Drive the machine forward for a short distance and brake.

Result:

- The driving speed must be working speed.
- Fully retract the telescopic arm.
- Drive the machine forward for a short distance and brake.

Result:

- The driving speed must be tortoise speed .

## DIFFERENTIAL LOCKING

Note: the diesel engine has been started. The machine is in transport position. The turntable and the platform are in neutral position. The jib arm is slightly raised.

Note: tortoise speed  is selected. 2 wheel steer mode  is selected. The front and rear wheels are aligned.

- Drive the machine forward and steer fully to the left or right.
- Press and hold down the differential lock button.

Result:

- The rear right-hand wheel or the rear left-hand wheel should slip.
- Align the front wheels.
- Release the differential lock button and brake the machine.
- Drive the machine forward and steer fully to the left or right.

Result:

- The wheel should no longer slip.
- Align the front wheels.
- Brake the machine.

## DRIVING ON A SLOPE AND TILT WARNING

Note: the diesel engine has been started. The machine is in transport position. The turntable and the platform are in neutral position. The jib arm is slightly raised.

Note: tortoise speed  is selected. 2 wheel steer mode  is selected. The front and rear wheels are aligned.

### TEST No. 1

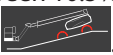
- Select a slope between 10.5% (6°) and 35% (19°).
- Select ramp speed .
- Raise the jib arm to the horizontal position.
- Drive the machine forward slowly onto the slope, facing it, with the platform at the bottom of the slope.

Result:

- The oscillation tilt/lock indicator light should light up.
  - The audible alarm should sound intermittently.
- Brake the machine on the slope.

Result:

- The brakes should function properly.
  - The machine should be immobilized on the slope for at least 1 minute.
- Try to raise the main arm, raise the secondary arm and extend the telescopic arm.

Result:

- It should not be possible to activate the functions.
- Reverse slowly to drive the machine off the slope onto a level surface.

Result:

- The oscillation tilt/lock indicator light should go out.
  - The audible alarm should stop.
- Brake the machine.

### TEST No. 2

- Extend the telescopic arm for 3 seconds.

Result:

- Drive the machine forward slowly onto the slope, facing it, with the platform at the bottom of the slope.

Result:

- The machine should brake automatically.
  - The oscillation tilt/lock indicator light should light up.
  - The audible alarm should sound intermittently.
- Try to raise the main arm, raise the secondary arm, extend the telescopic arm, tilt the platform/jib arm up, tilt the platform/jib arm down and drive/steer the machine.

Result:

- It should not be possible to activate the functions.
- Fully retract the telescopic arm.

Result:



- It should be possible to activate the function.
- Reverse slowly to drive the machine off the slope onto a level surface.

Result:

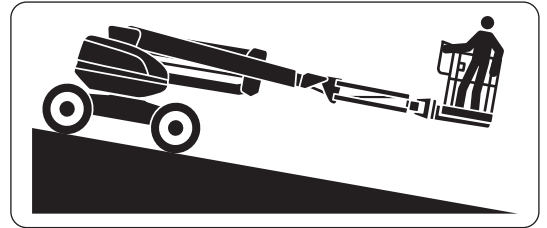
- The oscillation tilt/lock indicator light should go out.
  - The audible alarm should stop.
- Brake the machine.
  - Fully lower the jib arm.
  - Get out of the platform.
  - Switch off the machine.



### **TURNTABLE SLEWING ALARM (OPTION)**

- Start the diesel engine from the ground level control panel.
- Get into the platform.
- Select tortoise speed 
- Select 2 wheel steer mode 
- Raise the jib arm slightly for better visibility.
- Turn the turntable to the left so that the turntable angle is greater than 90° relative to the neutral position.

Result:

- The turntable slewing indicator light should come on.
- Try to drive and steer the machine.

Result:

- It should not be possible to activate the functions.
- The audible alarm should sound twice when trying to drive.
- Press and release the turntable slewing button.

Result:

- The turntable slewing indicator light should flash.
- Drive the machine forward/backward and steer left/right. Match up the black and white arrows on the chassis and on the control panel in the platform to drive/steer the machine in the desired direction.
- Brake the machine.

Result:

- It should not be possible to activate the driving/steering functions.
- The colors of the white and black arrows should make it possible to drive/steer the machine in the desired direction.
- Turn the turntable to the right so that the turntable angle is less than 90° relative to the neutral position.

Result:

- The turntable slewing indicator light should go out.
- Repeat the test from the start by turning the turntable to the right.
- Put the turntable in neutral position.
- Fully lower the jib arm.
- Align the front wheels.
- Get out of the platform.
- Switch off the machine.

## SECONDARY PROTECTION SYSTEM SPS (OPTION)

- Switch on the machine.

Result:

- The audible alarm should sound once.
- The flashing light SPS should flash several times and then go out.
- Start the diesel engine from the ground level control panel.
- Get into the platform.
- Check the condition of the safety cable SPS. If there is doubt about its condition, have it replaced by an approved professional from the Manitou network.
- Raise the jib arm slightly.
- Extend the telescopic arm for 3 seconds.
- Turn the platform to the right or left. At the same time, push the safety cable SPS forward and release it.

Result:

- The platform rotation should stop.
- The flashing light SPS should flash.
- The horn should sound intermittently.
- Try to activate all the machine's functions one by one.

Result:

- It should not be possible to activate any of the functions.
- Press and release the reset button SPS.

Result:

- The flashing light SPS should go out.
- The horn should stop.
- Fully retract the telescopic arm.

Result:

- It should be possible to activate the function.
- Extend the telescopic arm for 3 seconds.
- Turn the platform to the right or left. At the same time, push and hold the safety cable SPS forward.

Result:

- The platform rotation should stop.
- The flashing light SPS should flash.
- The horn should sound intermittently.
- Press and release the reset button SPS without releasing the safety cable SPS.
- Fully retract the telescopic arm.

Result:

- It should be possible to activate the function.
- Release the safety cable SPS.

Result:

- The flashing light SPS should go out.
- The horn should stop.
- Fully lower the jib arm.
- Get out of the platform.
- Switch off the machine.

## MONTHLY MAINTENANCE OR EVERY 50 HOURS OF SERVICE

ALSO PERFORM THE DAILY MAINTENANCE.

### CHECK

#### Alternator/fan belt

#### ⚠ IMPORTANT ⚠

Ensure that the machine is switched off.

If there is doubt about the condition of the belt, ⚠ 500H: REPLACE: ALTERNATOR/FAN BELT.

- Open the left-hand turntable cover.
- Remove the protective plate ①.
- Check the condition of the belt ②. Ensure there are no cracks or signs of wear.
- Check the belt tension between the crankshaft pulley and the alternator pulley:
  - Apply pressure with the thumb = 98 N. The clearance ④ must be between 7 mm and 9 mm to be correct.
- Adjust if necessary:
  - Loosen the screws ③.
  - Adjust the belt tension by swiveling the alternator.
  - Tighten the screws ③.
  - Check the belt tension again.
- Refit the protective plate ①.
- Close the left-hand turntable cover.

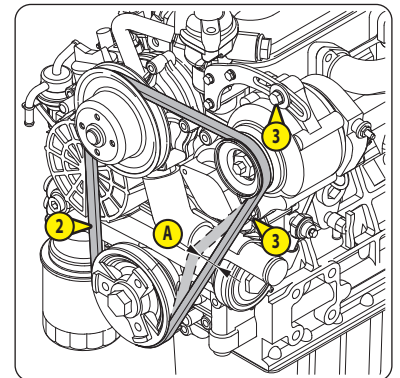
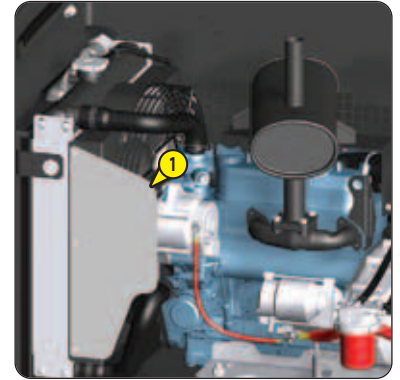

### CHECK

#### Injection pipes, fuel hoses and the hose clamps

#### ⚠ IMPORTANT ⚠

No flames or sparks. Do not smoke during this inspection.

If there is doubt about the condition of the injection pipes, fuel hoses and hose clamps, have them replaced by an authorized professional from the Manitou network.

- Put the safety strut in place, ⚠ OCCASIONAL OPERATIONS.
- Remove the battery cover ①.
- Remove the engine grille ②.
- Open the left-hand turntable cover.
- Check the condition of all the injection pipes, fuel hoses and the tightening clamps.
- Check for fuel leaks.
- Close the left-hand turntable cover.
- Put the engine grille back in place.
- Put the battery cover back in place.
- Remove the safety strut, ⚠ OCCASIONAL OPERATIONS.

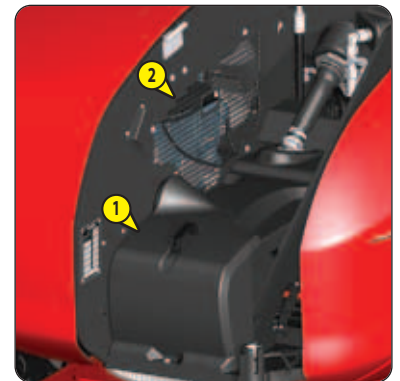

### CHECK

#### Reduction gearbox seal

- Locate the reduction gearbox ① on the rear axle.
- Check no oil is leaking from the reduction gearbox and plugs.
- If a leak is detected:
  - Clean the outside of the reduction gearbox with a clean cloth.
  - Remove the filler plug ②.
  - Check that the oil reaches the filling hole.
  - Add oil if necessary, ⚠ LUBRICANTS, COOLANT AND FUEL.
  - Refit the filler cap.

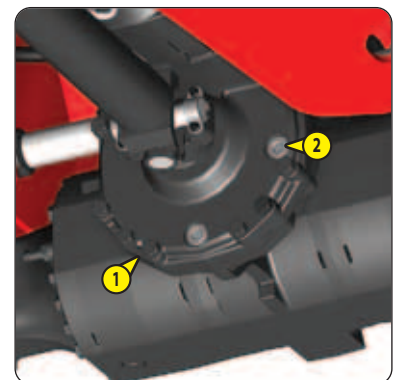

## CHECK

### Front and rear axle differential seals

- Check no oil is leaking from the differentials and plugs.
- If a leak is detected:
  - Clean the outside of the axle differential with a clean cloth.
  - Remove the filler plug ①.
  - Check that the oil reaches the filling hole.
  - Add oil if necessary, <img alt="oil can icon" data-bbox="265 142 278 155"/> LUBRICANTS, COOLANT AND FUEL.
  - Refit the filler cap.

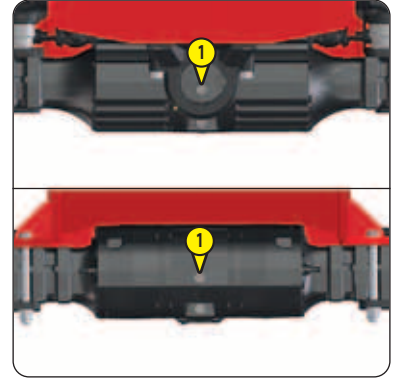

## CHECK

### Front and rear wheel reduction gear seals

- Note: check the wheel reduction gears one by one.
- Check no oil is leaking from the wheel reduction gears and plugs
  - If a leak is detected:
    - Turn the wheel to put the drain/filler plug ① in the horizontal position.
    - Clean the outside of the wheel reduction gear with a clean cloth.
    - Remove the drain/filler plug .
    - Check that the oil reaches the filling hole.
    - Add oil if necessary, <img alt="oil can icon" data-bbox="265 378 278 391"/> LUBRICANTS, COOLANT AND FUEL.
    - Refit the drain/filler plug:
- Tightening torque = 42 N.m ± 7 N.m



## CLEAN

### Coolant and oil radiators

#### IMPORTANT

*Clean the radiators more often when the machine is operating in a dusty environment.  
If there is any doubt about the condition of the hoses and hose clamps for the coolant radiators, have them replaced by an authorized professional from the Manitou network.*

- Open the left-hand turntable cover.
- Clean the radiators ① with compressed air, from the inside out.
- Check the condition of the hoses and hose clamps for the coolant radiator.
- Check the condition of the oil radiator.

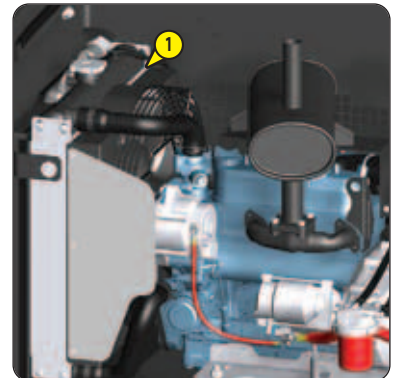

**⚠ IMPORTANT ⚠**

*Clean the outside air filter cartridge more often when the machine is operating in a dusty environment.  
 Never use the machine with a damaged air filter unit. If there is doubt about its condition, have it replaced by an approved professional from the Manitou network.  
 Never use the machine without the outside air filter cartridge or if it is damaged. If there is doubt about its condition, have it replaced by an approved professional from the Manitou network.  
 Never use the machine without the inside air filter cartridge or if it is damaged. If there is doubt about its condition, have it replaced by an approved professional from the Manitou network.  
 If there is doubt about the condition of the air intake line, the air suction outlet hose and hose clamps, have them replaced by an authorized professional from the Manitou network.*

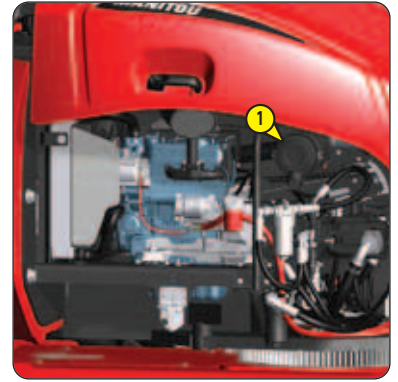

Note: the left-hand turntable cover is open.

- Clean the outside of the air filter unit **1** with a clean, slightly damp cloth.
- Unlock and remove the cover **2**.
- Clean the inside of the cover with a clean, slightly damp cloth.
- Remove the valve **3** and clean it with a clean, slightly damp cloth.
- Check the condition and replace it if it is damaged.
- Put the valve back in place.
- Remove the outside air filter cartridge **4**, pulling it gently to prevent dust dispersion.

Note: do not press the center of the outside air filter cartridge.

- Check the condition of the inside air filter cartridge **5** without taking it out.
- Check the condition of the air filter unit, the air intake line, the air suction outlet hose and the tightening clamps.
- Clean the outside air filter cartridge **4** by tapping it gently.

Note: if necessary, clean it with dry compressed air, from the inside out. Maximum pressure = 2 bars. Minimum distance = 30 mm.

- Check its condition and clean its seal with a clean cloth.
- Refit the outside air filter cartridge, pushing it gently.

Note: do not press the center of the outside air filter cartridge.

- Refit the cover **2**, with the valve **3** facing downward and the marking "TOP" facing upward.
- Close the left-hand turntable cover.

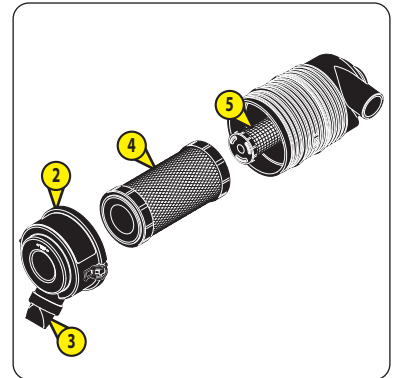

**⚠ IMPORTANT ⚠**

*Lubricate the axle more often when the machine is operating in a dusty environment.*

**FRONT AND REAR STEERING PIVOTS**

Note: the illustration shows a 160 ATJ.

- Remove the caps from the lubrication connectors **1**, at the front and at the rear, on the right and left-hand sides.
- Inject lubricant into the lubrication connectors,  LUBRICANTS, COOLANT AND FUEL.
- Refit the caps of the lubrication connectors.

**OSCILLATING FRONT AXLE BEARINGS**

- Remove the caps from the lubrication connectors **2**.
- Inject lubricant into the lubrication connectors,  LUBRICANTS, COOLANT AND FUEL.
- Refit the caps of the lubrication connectors.

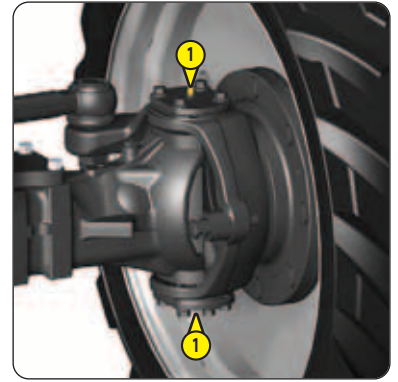

**CHECK**

**230 V electric power socket in the platform (OPTION)**

**⚠ IMPORTANT ⚠**

*Connect the plug to a 230 V/50 Hz power source delivering 16 A.*

*Only connect electrical appliances that work with 230 V/50 Hz, 16 A maximum.*

*Do not connect extension cords, power supply bars or plugs with multiple sockets to the electric power socket.*

Note: the illustrations show a 160 ATJ with a standard platform.

- Connect the plug ① to a power source.
- Plug an electrical appliance into the electric power socket ② and turn it on.

Result:

- The electrical appliance should operate.
- Open the electrical box cover panel ③A.
- Press and release the test button ③B.

Result:

- The switch ③C must move from the ON position to the OFF position, the indicators ③D and ③E should be green.
- The electrical appliance should not operate.
- Turn off the power to the electrical appliance.
- Push the switch ③C to the ON position.

Result:

- The switch must remain in the ON position, the indicators should be red.
- Switch the electrical appliance on.

Result:

- The electrical appliance should operate.
- Disconnect the electrical appliance.
- Disconnect the electrical plug.

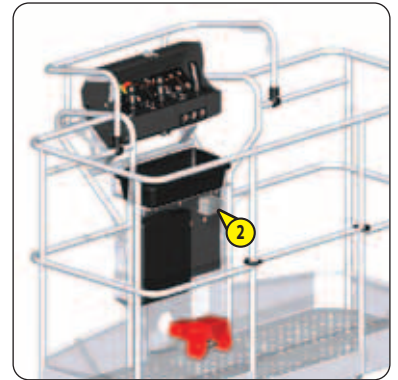
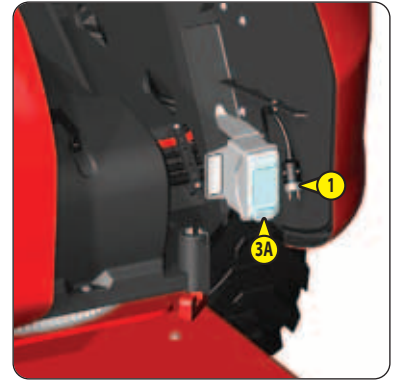

**⚠ IMPORTANT ⚠**

Only connect electrical appliances that work with 230 V/50 Hz, 16 A maximum (230 V 3.5 kW electric generator option and 230 V 5 kW electric generator option).

Do not connect extension cords, power supply bars or plugs with multiple sockets to the electric power socket(s).

Note: the illustrations show a standard platform.

- Start the diesel engine.
- Start the electric generator.
- 230 V 3.5 kW electric generator option:
  - Plug an electrical appliance into the electric power socket ①.
- 230 V 5 kW electric generator option:
  - Plug an electrical appliance into one of the electric power sockets ②.

Result:

- The electrical appliance should operate.
- 230 V 5 kW electric generator option:
  - Turn off the power to the electrical appliance.
  - Plug it in to the other electric power socket ②.

Result:

- The electrical appliance should operate.
- Open the left-hand turntable cover.
- Press and release the test button ③A.

Result:

- The switch ③B must move from the ON position to the OFF position, the indicator ③C should be green.
- The electrical appliance should not operate.
- Turn off the power to the electrical appliance.
- Push the switch ③B to the ON position.

Result:

- The switch must remain in the ON position, the indicator should be red.
- Switch the electrical appliance on.

Result:

- The electrical appliance should operate.
- Disconnect the electrical appliance.
- Stop the generator.
- Close the left-hand turntable cover.
- Switch off the machine.

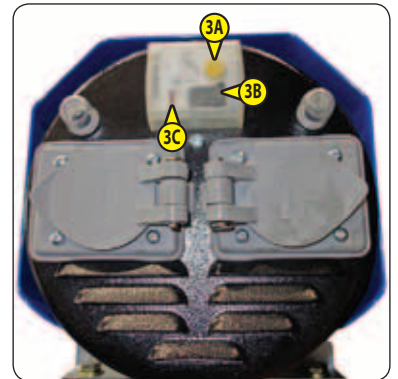
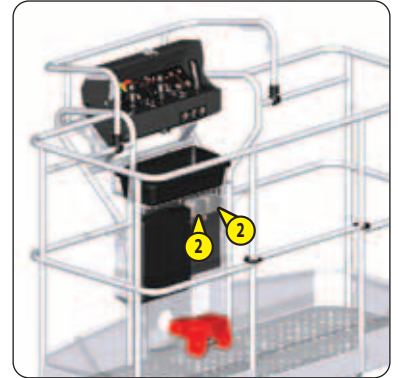
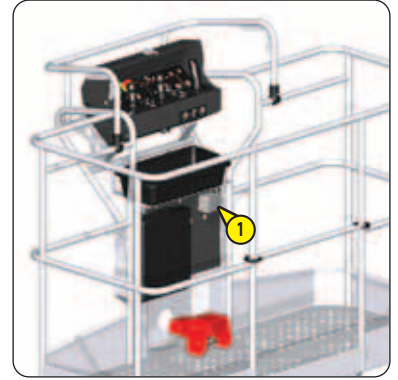

## ➔ 1 250H - PERIODIC MAINTENANCE - EVERY 250 HOURS OF SERVICE OR 6 MONTHS

ALSO PERFORM THE DAILY MAINTENANCE.

### CHECK

#### Alternator/fan belt

⚠ 50H: MONTHLY MAINTENANCE OR EVERY 50 HOURS OF SERVICE.

### CHECK

#### Injection pipes, fuel hoses and the hose clamps

⚠ 50H: MONTHLY MAINTENANCE OR EVERY 50 HOURS OF SERVICE.

### CHECK

#### Reduction gearbox seal

⚠ 50H: MONTHLY MAINTENANCE OR EVERY 50 HOURS OF SERVICE.

### CHECK

#### Front and rear axle differential seals

⚠ 50H: MONTHLY MAINTENANCE OR EVERY 50 HOURS OF SERVICE.

### CHECK

#### Front and rear wheel reduction gear seals

⚠ 50H: MONTHLY MAINTENANCE OR EVERY 50 HOURS OF SERVICE.

### CHECK

#### 230 V electric power socket in the platform (OPTION)

⚠ 50H: MONTHLY MAINTENANCE OR EVERY 50 HOURS OF SERVICE.

### CHECK

#### Electric generator (OPTION)

⚠ 50H: MONTHLY MAINTENANCE OR EVERY 50 HOURS OF SERVICE.

### CHECK

#### Wheel nut tightening

#### ⚠ IMPORTANT ⚠

*Failure to follow this instruction may result in the machine tipping over.*

- Check the tightening torques of all the wheel nuts:
  - 360 N.m ±36 N.m

### CHECK

#### Tightening of the fixing screws for the oscillating cylinders

#### ⚠ IMPORTANT ⚠

*Failure to follow this instruction may result in the machine tipping over.*

Note: the illustration shows a 160 ATJ.

- Check the tightening torques of all the fixing screws ①, on the left and right-hand sides:
  - 247 N.m ±11.5 N.m

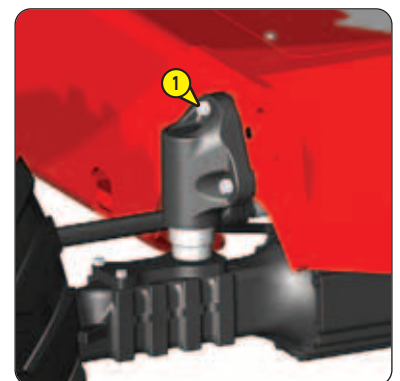

## CHECK

### Tightening of the transmission shaft fixing screws

#### ⚠ IMPORTANT ⚠

*Failure to follow this instruction may result in the machine running away.*

- Check the tightening torques of all the fixing screws ①, at the front and rear:
  - 37 N.m  $\pm$ 3.5 N.m

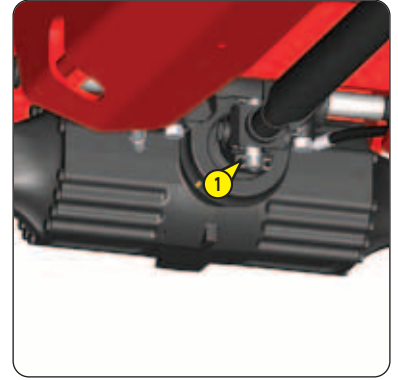

## CHECK

### Tightening of the fixing screws for the axles

#### ⚠ IMPORTANT ⚠

*Failure to follow this instruction may result in the machine tipping over.*

Note: the illustrations show a 160 ATJ.

- Check the tightening torques of all the fixing screws:
  - ① (Front axle oscillating bearings) = 375 N.m  $\pm$ 74 N.m
  - ② (Rear axle, left and right sides) = 270 N.m  $\pm$ 27 N.m



**⚠ IMPORTANT ⚠**

*Failure to follow this instruction may result in the machine tipping over.*

- Place a sufficiently solid ramp in front of the front right-hand wheel:
  - A = 7.5 cm minimum, 9 cm maximum.
  - B = 60 cm minimum.
  - C = 75 cm minimum, 100 cm maximum.
  - D = 10° minimum, 25° maximum.
- Start the diesel engine.
- Get into the platform.
- Select ramp speed .
- Raise the jib arm slightly.
- Drive the machine slowly forward until the front right-hand wheel is at the top of the ramp.
- Brake the machine.
- Turn the turntable 90° to the left.
- Extend the telescopic arm for 3 seconds.
- Reverse the machine slowly until the wheel is off the slope.
- Brake the machine.
- Ask someone on the ground to check the right front wheel and the oscillating cylinders.

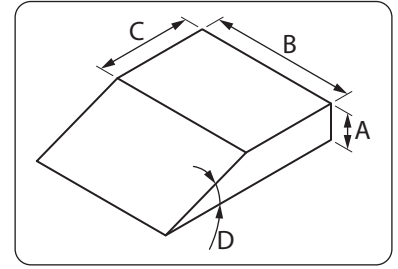

Result:

- The right front wheel should be in the upper position and not in contact with the ground.
- The right oscillating cylinder should be retracted and the left one extended.
- Ask the person on the ground to move away.
- Fully retract the telescopic arm.
- Ask the person on the ground to check the front wheels.

Result:

- The two front wheels must be in contact with the ground.
- Put the turntable in neutral position.
- Fully lower the jib arm.
- Get out of the platform.
- Place the same ramp in front of the left front wheel.
- Get into the platform.
- Raise the jib arm slightly.
- Drive the machine slowly forward until the front left-hand wheel is at the top of the ramp.
- Brake the machine.
- Turn the turntable 90° to the right.
- Extend the telescopic arm for 3 seconds.
- Reverse the machine slowly until the wheel is off the slope.
- Brake the machine.
- Ask the person on the ground to check the left front wheel and the oscillating cylinders.

Result:

- The left front wheel should be in the upper position and not in contact with the ground.
- The left oscillating cylinder should be retracted and the right one extended.
- Ask the person on the ground to move away.
- Fully retract the telescopic arm.
- Ask the person on the ground to check the front wheels.

Result:

- The two front wheels must be in contact with the ground.
- Put the turntable in neutral position.
- Fully lower the jib arm.
- Get out of the platform.

**⚠ IMPORTANT ⚠**

*Failure to follow this instruction may result in the machine tipping over.  
Refer to the machine repair manual if the overload system is not correctly calibrated.*

Note: the diesel engine has been started. The machine is in transport position. The turntable and the platform are in neutral position. The jib arm is completely lowered.

- Switch on the machine.
- Place a uniformly distributed load in the platform = 253 kg.

Result:

- An alert page must be displayed on the ground level display screen.
- The audible alarm should sound continuously.
- Try to activate all the machine's functions one by one using the ground level control panel.

Result:

- It should not be possible to activate any of the functions.
- Remove 23 kg to obtain a load of 230 kg in the platform:

Result:

- The alert page should no longer be displayed.
- The audible alarm should stop.
- Activate all the machine's functions one by one.

Result:

- It should be possible to activate all the functions.
- Place the machine in transport position. Put the turntable in neutral position. Level the platform/jib arm. Fully lower the jib arm.
- Get into the platform.

Result:

- The overload indicator light should flash.
- An alert page must be displayed on the platform display screen.
- The audible alarm should sound continuously.
- Try to activate all the machine's functions one by one using the platform control panel.

Result:

- It should not be possible to activate any of the functions.
- Get out of the platform.

Result:

- The overload indicator light should go out.
- The alert page should no longer be displayed.
- The audible alarm should stop.
- Remove the whole load from the platform.
- Switch off the machine.

**⚠ IMPORTANT ⚠**

*Failure to follow this instruction may result in the machine running away.*

**PLACING IN FREEWHEEL MODE**

Note: the machine is powered down. The machine is in transport position. The turntable and the platform are in neutral position. The jib arm is completely lowered.

- Carry out the complete procedure described in 2- DESCRIPTION: TRANSPORT AND LIFTING: FREEWHEEL FOR TOWING/ WINCHING.

**BRAKING DISTANCE ON A LEVEL SURFACE**

Note: the machine is powered down. The machine is in transport position. The turntable and the platform are in neutral position. The jib arm is completely lowered.

- Select a level surface for the following test.
- Start the diesel engine.
- Place a uniformly distributed load in the platform = 230 kg less your body weight.
- Get into the platform.

- Select hare speed .
- Raise the jib arm slightly for better visibility.

Drive the machine forward until the top speed is reached.

- Release the control handle to brake the machine.

Result:

- The braking distance must be: 1,400 mm  $\pm$ 300 mm.
- Extend the telescopic arm for 3 seconds.
- Drive the machine forward until the top speed is reached:

Note: the driving speed must be working speed.

- Release the control handle to brake the machine.

Result:

- The braking distance should be: 200 mm  $\pm$ 50 mm.
- Fully retract the telescopic arm and fully lower the jib arm.

**BRAKING ON A SLOPE**

Note: the diesel engine has been started. The machine is in transport position. The turntable and the platform are in neutral position. The jib arm is slightly raised. The previous test load is in the platform.

- Select a slope of 25% (14°) for the following test.
- Raise the jib arm to the horizontal position.
- Drive the machine forward slowly onto the slope, facing it, with the platform at the bottom of the slope.
- Release the control handle to brake the machine on the slope.

Result:

- The machine should be immobilized on the slope for at least 1 minute.
- Drive the machine off the slope.
- Fully lower the jib arm.
- Get out of the platform.
- Remove the whole load from the platform.
- Switch off the machine.

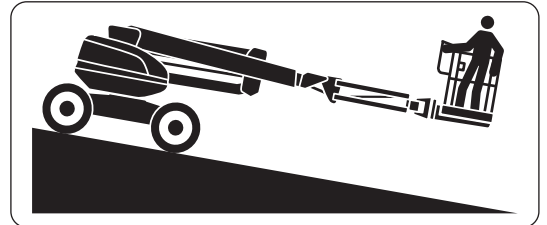

## CHECK

### Turntable rotation motor oil level

- Put the safety strut in place, ⚠ OCCASIONAL OPERATIONS.
- Remove the battery cover ①.
- Check no oil is leaking from the turntable rotation motor ②.
- Remove the filler plug ③.
- Clean the dipstick on the filler cap with a clean cloth and put it back in place.
- Remove the filler cap. The level is correct when the oil is between the 2 marks A and B.
- If the level is low, add oil until the correct level is reached, ⚠ LUBRICANTS, COOLANT AND FUEL.
- Refit the filler cap.
- Put the battery cover back in place.
- Remove the safety strut, ⚠ OCCASIONAL OPERATIONS.

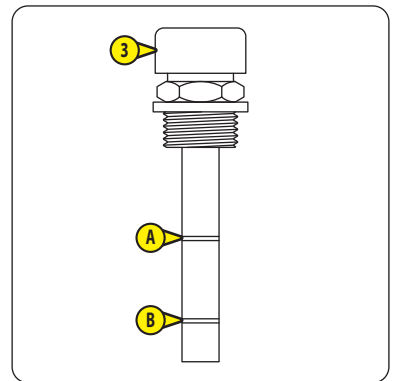

## CHECK

### Emergency controls

#### **⚠ IMPORTANT ⚠**

*Use of the machine if there is a malfunction is prohibited.*



- Check that the emergency controls are working: carry out the complete procedures described in 2 - DESCRIPTION: EMERGENCY CONTROLS.

**⚠ IMPORTANT ⚠**

*Always secure the raised arms with a suitable lifting device.*

Note: the illustration shows a 160 ATJ.

- Start the diesel engine.
- Perform the appropriate main arm, secondary arm and platform/jib arm tilt movements to access the various lubricators. Secure the raised arms with a suitable lifting device.
- Open the right-hand turntable cover.
- Remove the caps of the lubrication connectors.
- Inject lubricant into each lubrication connector, <math>\sphericalangle</math> LUBRICANTS, COOLANT AND FUEL.
- Refit the caps of the lubrication connectors.
- Fully lower the main arm. Fully lower the secondary arm. Level the platform/jib arm. Fully lower the jib arm.
- Close the right-hand turntable cover.

<b>KEY</b>
<b>SHAFT</b>

<b>HUB</b>

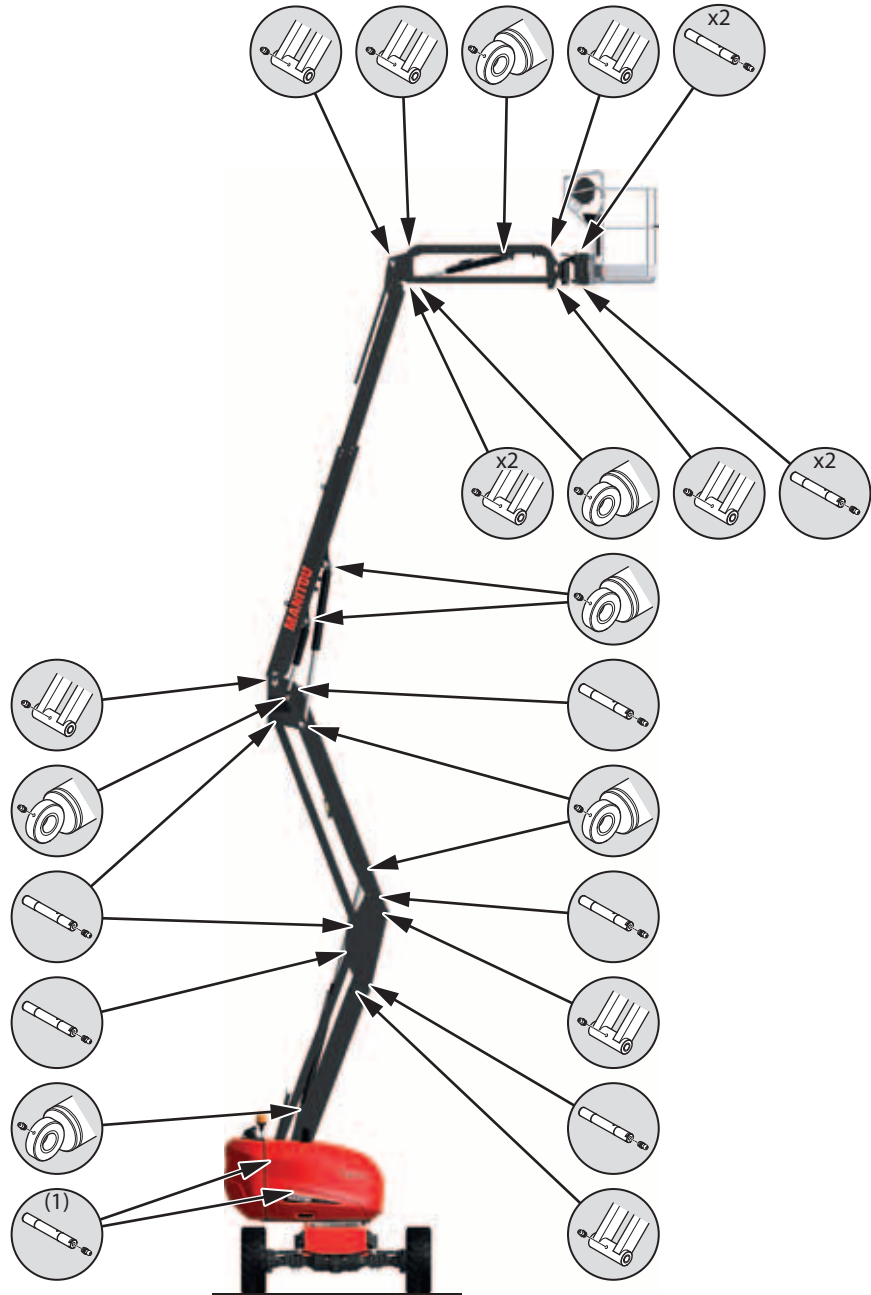
<b>CYLINDER RING</b>

(1) under the right-hand turntable



**⚠ IMPORTANT ⚠**

*Lubricate the telescopic arm more often when the machine is operating in a dusty environment.*

Note: the diesel engine has been started.

- Raise the jib arm slightly.
- Fully extend the telescopic arm.
- Check the sliding surfaces **A** of the pads:
  - Surfaces must be smooth and free from corrosion.
- Lubricate the telescopic arm if necessary, **LUBRICANTS, COOLANT AND FUEL**.

Note: extend and retract the telescopic arm several times to spread the lubricant.  
Remove the excess with a clean cloth.

- Fully retract the telescopic arm.
- Fully lower the jib arm.
- Switch off the machine.

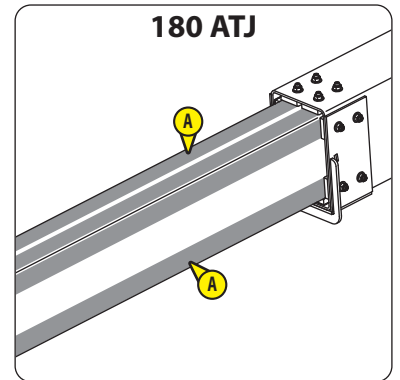
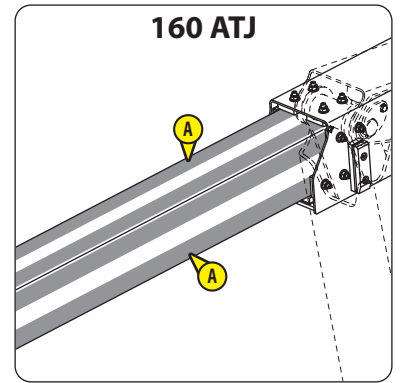

**LUBRICATE**

**Crown gear**

- Remove the right-hand and left-hand chassis covers.
- Remove the caps of the 2 lubrication connectors **1** for the crown gear.
- Inject lubricant into the lubrication connectors, **LUBRICANTS, COOLANT AND FUEL**.
- Start the diesel engine.
- Turn the turntable 90° to the left or the right and inject lubricant again.
- Refit the caps of the lubrication connectors.
- Refit the right-hand and left-hand chassis covers.
- Lubricate the teeth of the crown gear **2**, **LUBRICANTS, COOLANT AND FUEL**.
- Turn the turntable a full turn to spread the lubricant.
- Put the turntable in neutral position.
- Switch off the machine.

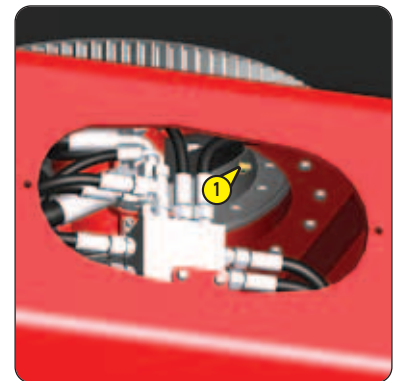

## CHECK

## Tightening of 12 V electrical connections

### ⚠ IMPORTANT ⚠

*Electrical accreditation may be required for this maintenance operation: comply with local, governmental and national regulations in force.*

*Make sure that the positive terminals cannot come into contact with the negative terminals or the metallic parts of the machine at any time.*

*After each job, make sure that the electrical component protection systems are put back (covers, caps, grommets, etc.).*

- Put the safety strut in place, ⚠ OCCASIONAL OPERATIONS.
- Remove the battery cover ①.
- Open the left and right-hand turntable covers.
- Check the condition of the 12 V electrical wires:
  - Between the battery and the turntable.
  - Without battery cut-off option: between the battery and the fuse box.
  - With battery cut-off option: between the battery and the battery cut-off.
  - With battery cut-off option: between the battery cut-off and the fuse box.
  - Between the fuse box and the backup pump.
  - Between the backup pump and the turntable
  - Between the fuse box and the starter.
  - Without battery cut-off option: between the starter and the alternator.
  - With battery cut-off option: between the battery cut-off and the alternator
  - Between the fuse box and the fuse/relay box.
  - Between the fuse/relay box and the ground level control panel.
  - Between the fuse/relay box and the preheat plugs.
- Check the condition of the ground braid between the diesel engine and the turntable.
- Check the tightening of the 12 V electrical connections:
  - On the battery.
  - With battery cut-off option: on the battery cut-off.
  - On the fuse box.
  - On the fuse/relay box.
  - On the starter
  - On the alternator.
  - On the backup pump.
  - On the turntable (2 electrical connections).
- Put the battery cover back in place.
- Remove the safety strut, ⚠ OCCASIONAL OPERATIONS.
- Close the left and right-hand turntable covers.



## RESET

## Maintenance warning

- Switch on the machine.
- Access the maintenance menu on the ground level display screen.
- Reset the maintenance warning.
- Return to the work page.
- Switch off the machine.

## 🔄 500H - PERIODIC MAINTENANCE - EVERY 500 HOURS OF SERVICE OR 1 YEAR

ALSO PERFORM THE DAILY SERVICE AND THE PERIODIC SERVICE AT 250 HOURS OF SERVICE.

### CHECK

### Tilt sensor

#### ⚠️ IMPORTANT ⚠️

Failure to follow this instruction may result in the machine tipping over.

The machine must be in transport position with the turntable and the platform in neutral position and with the jib arm fully lowered.

- Start the diesel engine.
- Place the machine on a level surface.
- Access the "tilt calibration" menu on the ground level display screen.
- Check that the value displayed is  $0^\circ \pm 0.3^\circ$ .
- If the value is within the tolerances: return to the work page.
- If the value is outside the tolerances: refer to the machine repair manual to calibrate the tilt sensor.
- Switch off the machine.

### CHECK

#### Tightening of the platform fixing screws

#### ⚠️ IMPORTANT ⚠️

Failure to follow this instruction may result in the platform falling.

- Check the tightening torques of all the fixing screws ① (quantity = 6):
  - $90 \text{ N.m} \pm 17.5 \text{ N.m}$

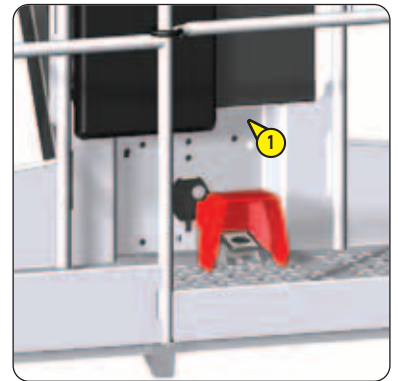

### CHECK

#### Tightening of the platform rotation cylinder fixing screws

#### ⚠️ IMPORTANT ⚠️

Failure to follow this instruction may result in the platform falling.

- Check the tightening torques of all the fixing screws ①:
  - $60 \text{ N.m} \pm 10 \text{ N.m}$
- Check the tightening torque of the pin ②:
  - $80 \text{ N.m} \pm 16 \text{ N.m}$

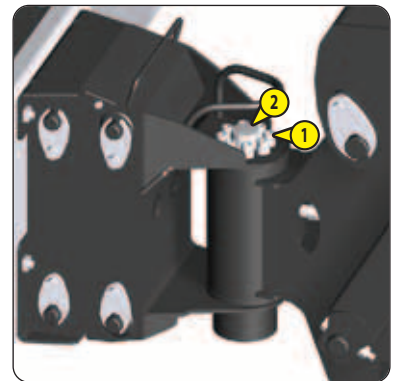

**⚠ IMPORTANT ⚠**

*It is recommended that the telescopic arm chocking is adjusted if the clearances are greater than the maximum values. Refer to the machine's repair manual.*

- Check the tightening torques of all the nuts **1**:
  - 69 N.m ± 6.5 N.m
- Start the diesel engine.
- Raise the jib arm slightly.
- Extend the telescopic arm for 1 second.
- Check the clearances between the pads and the telescopic arm:
  - **A** (upper pad **2**) should be between 1 mm and 1.5 mm.
  - **B** (Side pads **3**) must be between 0.5 mm and 0.75 mm on either side.
- Fully extend the telescopic arm.
- Check the clearances **A** and **B** again.
- Fully retract the telescopic arm.
- Fully lower the jib arm.
- Take off the cover **4**.
- Raise the main arm slightly.
- Place several wooden pallets under the platform.
- Slowly lower the main arm until the pads **5** are in contact with the main arm.
- Check the clearances between the pads and the main arm:
  - **C** (Upper pads **6**) must be between 1 mm and 1.5 mm.
  - **D** (Side pads **7**) must be between 0.5 mm and 0.75 mm on either side.
- Raise the main arm slightly.
- Remove the wooden pallets.
- Fully lower the main arm.
- Switch off the machine.
- Put the cover **4** back in place.

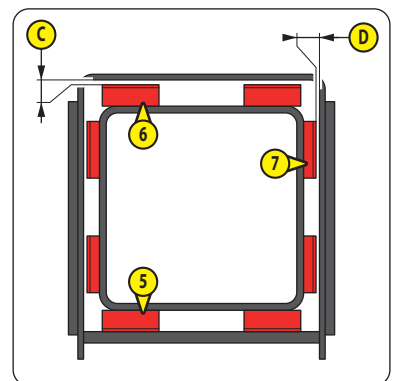
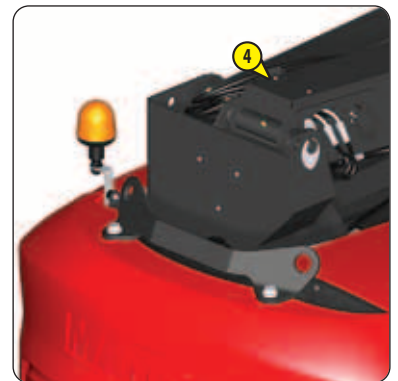
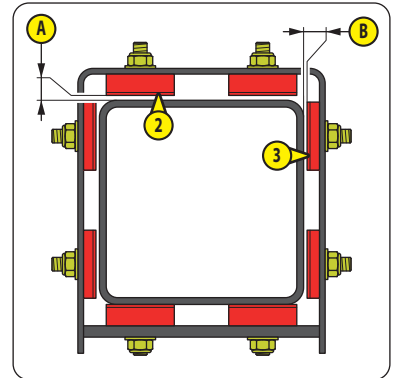
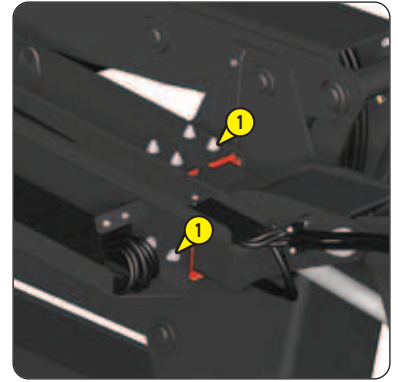

**⚠ IMPORTANT ⚠**

*It is recommended that the telescopic arm chocking is adjusted if the clearances are greater than the maximum values.  
Refer to the machine's repair manual.*

- Check the tightening torques of all the nuts **1**:
  - 69 N.m ± 6.5 N.m
- Start the diesel engine.
- Raise the jib arm slightly.
- Extend the telescopic arm for 1 second.
- Check the clearances between the pads and the telescopic arm:
  - **A** (upper pad **2**) should be between 1 mm and 1.5 mm.
  - **B** (Side pads **3**) must be between 0.5 mm and 0.75 mm on either side.
- Fully extend the telescopic arm.
- Check the clearances **A** and **B** again.
- Fully retract the telescopic arm.
- Fully lower the jib arm.
- Take off the cover **4**.
- Raise the main arm slightly.
- Place several wooden pallets under the platform.
- Slowly lower the main arm until the pads **5** are in contact with the main arm.
- Check the clearances between the pads and the main arm:
  - **C** (Upper pads **6**) must be between 1 mm and 1.5 mm.
  - **D** (Side pads **7**) must be between 0.5 mm and 0.75 mm on either side.
- Raise the main arm slightly.
- Remove the wooden pallets.
- Fully lower the main arm.
- Switch off the machine.
- Put the cover **4** back in place.

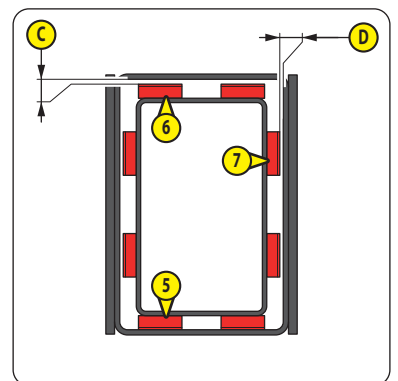
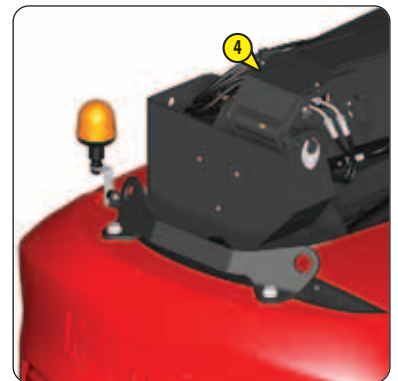
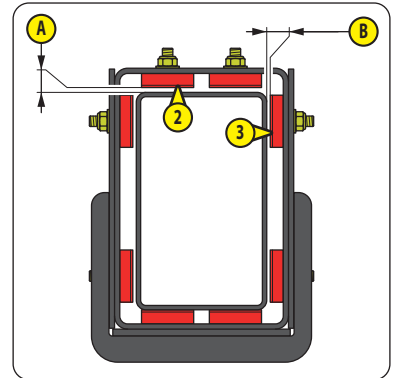
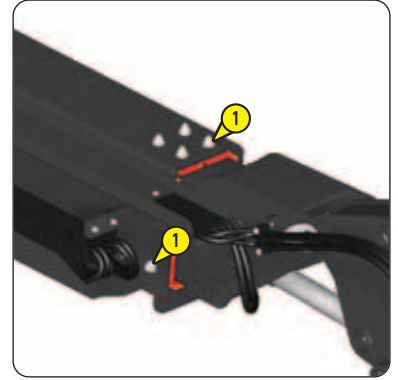

**CHECK**

**Tightening of the fixing screws for the crown gear**

**⚠ IMPORTANT ⚠**

*Failure to follow this instruction may result in the machine tipping over.*

- Put the safety strut in place, ⚠ OCCASIONAL OPERATIONS.
- Remove the battery cover ①.
- Remove the engine grille ②.
- Open the left-hand turntable cover.
- Locate the 2 holes A.
- Start the diesel engine.
- Turn the turntable to align the holes A with 2 fixing screws ③.
- Check the tightening torques of the first 2 fixing screws ③:
  - 215 N.m ± 21 N.m
- Turn the turntable to align the holes A with the next 2 fixing screws ③ to check their tightening torques.
- Repeat the steps until the tightening torque for each fixing screw ③ has been checked.
- Check the tightening torques of the fixing screws ④:
  - 215 N.m ± 21 N.m
- Put the turntable in neutral position.
- Switch off the machine.

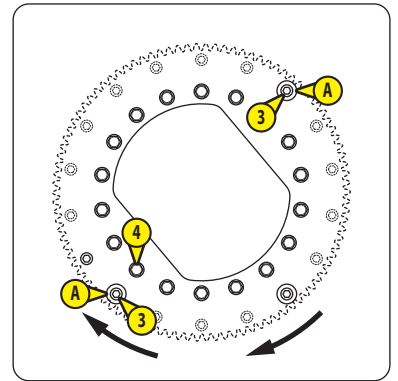
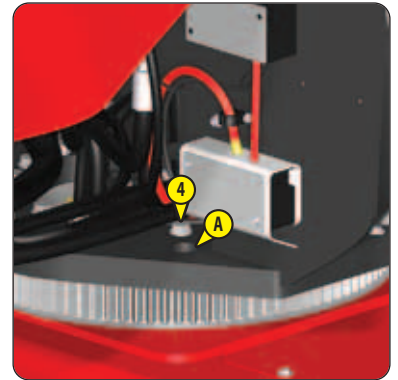
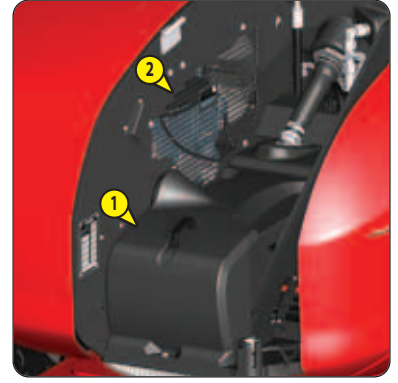

**CHECK**

**Tightening of the fixing screws on the turntable rotation motor**

**⚠ IMPORTANT ⚠**

*Failure to follow this instruction may result in involuntary movement of the turntable.*

- Note: the safety strut is put in place. The battery cover is removed. The engine grid is removed. The left-hand turntable cover is open.
- Check the tightening torques of all the fixing screws ①:
    - 76 N.m ± 15 N.m

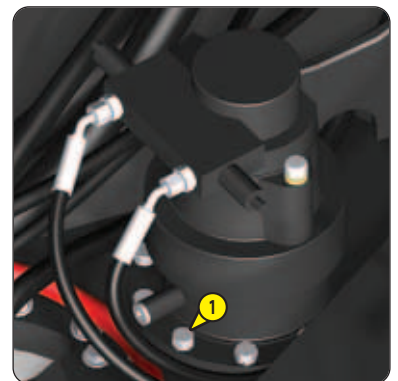

## CHECK

### Counterweight fixing screw tightening

#### **⚠ IMPORTANT ⚠**

*Failure to follow this instruction may result in the machine tipping over.*

Note: the safety strut is put in place. The battery cover is removed. The engine grid is removed. The left-hand turntable cover is open.

- Open the right-hand turntable cover.
- Check the tightening torques of all the fixing screws ①, on the left and right-hand sides:
  - 700 N.m ± 70 N.m

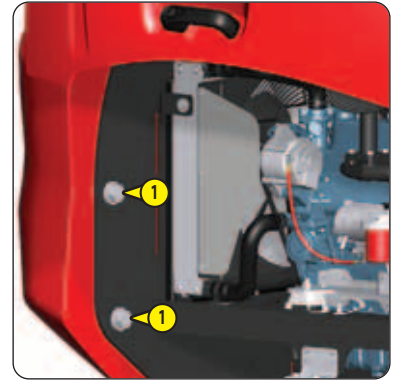

## CHECK

### Lifting support fixing screw tightening

#### **⚠ IMPORTANT ⚠**

*Failure to apply this instruction may result in the machine falling during lifting.*

Note: the illustration shows a 160 ATJ.

Note: the safety strut is put in place. The battery cover is removed. The engine grid is removed. The right and left-hand turntable covers are open.

- Check the tightening torques of all the fixing screws ①, on the left and right-hand sides:
  - 700 N.m ± 70 N.m

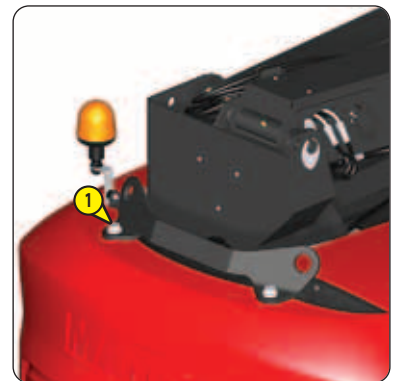

## CHECK

### Hydraulic hoses

#### **⚠ IMPORTANT ⚠**

*Always use a piece of paper or cardboard to check there are no hydraulic oil leaks.  
Replace any damaged hydraulic hoses.*

Note: the safety strut is put in place. The battery cover is removed. The engine grid is removed. The right and left-hand turntable covers are open.

- Remove the right-hand and left-hand chassis covers.
- Remove the front and rear chassis covers.
- Check the condition of all the hydraulic hoses and that there are no leaks.
- Refit the front and rear chassis covers.
- Refit the right-hand and left-hand chassis covers.
- Close the right-hand turntable cover.

## REPLACE

## Alternator/fan belt

Note: the safety strut is put in place. The battery cover is removed. The engine grid is removed. The left-hand turntable cover is open.

- Remove the protective plate ①.
- Replace the belt ②, <img alt="arrow pointing left" data-bbox="225 121 245 131"/> FILTER CARTRIDGES AND BELTS:
  - Loosen the screws ③.
  - Remove the used belt by swiveling the alternator.
  - Replace it with a new belt.
  - Tighten the screws ③.
- Check the belt tension between the crankshaft pulley and the alternator pulley:
  - Apply pressure with the thumb = 98 N. The clearance ④ must be between 7 mm and 9 mm to be correct.
- Adjust if necessary:
  - Loosen the screws ③.
  - Adjust the belt tension by swiveling the alternator.
  - Tighten the screws ③.
  - Check the belt tension again.
- Refit the protective plate ①.

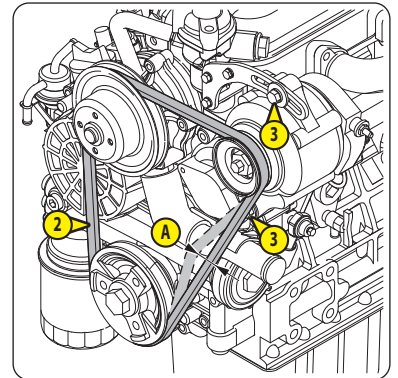
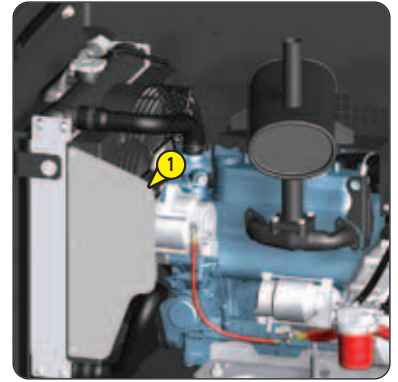

## REPLACE

## Fuel pre-filter

### IMPORTANT

*No flames or sparks. Do not smoke during this replacement.*

Note: the safety strut is put in place. The battery cover is removed. The engine grid is removed. The left-hand turntable cover is open.

- Locate the fuel pre-filter ① and put a drain pan underneath.
- Replace the fuel pre-filter, <img alt="arrow pointing left" data-bbox="225 557 245 567"/> FILTER CARTRIDGES AND BELTS:
  - Remove the used fuel pre-filter.
  - Check the condition of the fuel hoses and the hose clamps. Replace them if necessary.
  - Put the new fuel pre-filter in place. Make sure that the hose clamps are properly in place.

Note: adhere to the fitting direction for the fuel pre-filter shown by an arrow.



**⚠ IMPORTANT ⚠**

*No flames or sparks. Do not smoke during this replacement.  
Never use the machine without the fuel filter cartridge or if it is damaged.*

Note: the safety strut is put in place. The battery cover is removed. The engine grid is removed. The left-hand turntable cover is open.

- Clean the outside of the fuel filter ① with a clean cloth.
- Turn the tap ② to the OFF position "OFF".
- Replace the fuel pre-filter ③, <img alt="arrow icon" data-bbox="315 185 325 195"/> FILTER CARTRIDGES AND BELTS:
  - Unscrew the retaining ring ④.
  - Remove the tank ⑤ and the used fuel filter cartridge.
  - Clean the tank with clean fuel, <img alt="arrow icon" data-bbox="315 230 325 240"/> LUBRICANTS, COOLANT AND FUEL.
  - Check its condition. Replace it if necessary.
  - Refit the new fuel filter cartridge, tank and retaining ring.
- Check the condition of the fuel hoses and the hose clamps. Replace them if necessary.
- Bleed the fuel supply circuit <img alt="arrow icon" data-bbox="315 285 325 295"/> OCCASIONAL MAINTENANCE.

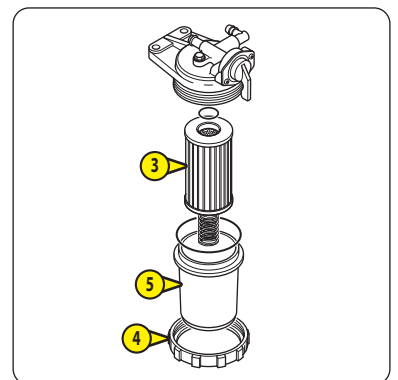
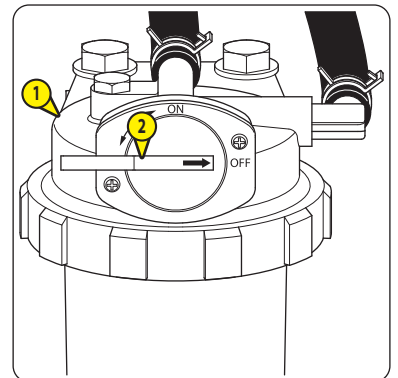
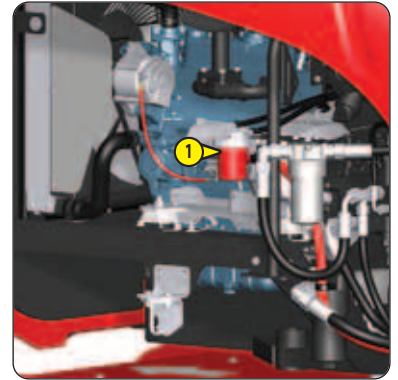

## REPLACE

## Diesel engine oil

## REPLACE

## Diesel engine oil filter

### ⚠ IMPORTANT ⚠

Note: the safety strut is put in place. The battery cover is removed. The engine grid is removed. The left-hand turntable cover is open.

### CHANGE THE OIL

- Start the diesel engine.
- Allow it to idle for 5 minutes.
- Switch off the machine.
- Locate the drain plug **1** and put a drain pan underneath.
- Remove the drain plug and the filler plug **2**.
- Wait until the crankcase is completely empty.

### REPLACE THE DIESEL ENGINE OIL FILTER

- Place a drain pan under the diesel engine oil filter **3**.
- Replace the diesel engine oil filter, **↩ FILTER CARTRIDGES AND BELTS:**
  - Unscrew the used diesel engine oil filter.
  - Lubricate the seal of the new diesel engine oil filter with clean diesel engine oil, **↩ LUBRICANTS, COOLANT AND FUEL.**
  - Screw up the new diesel engine oil filter by hand and tighten it by a three-quarter turn using the oil filter wrench.

### FILL THE DIESEL ENGINE

- Clean around the drain hole with a clean cloth.
- Refit the drain plug.
- Fill the diesel engine with new diesel engine oil, **↩ LUBRICANTS, COOLANT AND FUEL.**
- Wait 5 minutes for the oil to settle in the crankcase.
- Refit the filler cap.
- Check the diesel engine oil level, **↩ DAILY MAINTENANCE: CHECK DIESEL ENGINE OIL LEVEL.**
- Start the diesel engine.
- Allow the diesel engine to run for 5 minutes.
- Check for leaks.
- Switch off the machine.
- Wait 5 minutes for the oil to settle in the crankcase.
- Check the diesel engine oil level again and top up if necessary, **↩ DAILY MAINTENANCE: CHECK DIESEL ENGINE OIL LEVEL.**

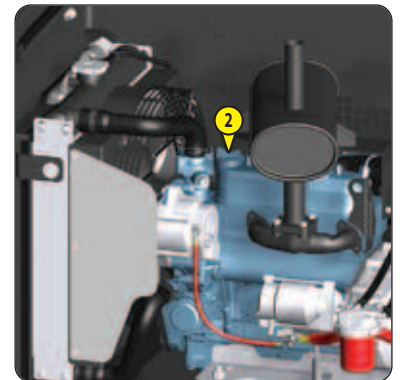
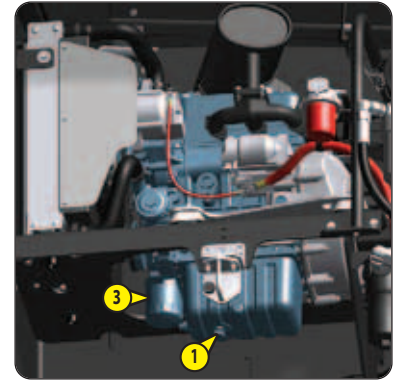

**⚠ IMPORTANT ⚠**

*Never use the machine with a damaged air filter unit. If there is doubt about its condition, have it replaced by an approved professional from the Manitou network.*

*Never use the machine without the outside air filter cartridge or if it is damaged.*

*Never use the machine without the inside air filter cartridge or if it is damaged. If there is doubt about its condition,*

*⚠ ⌚ 1000H: REPLACE: INSIDE AIR FILTER CARTRIDGE.*

*If there is doubt about the condition of the air intake line, the air suction outlet hose and hose clamps,*

*⚠ ⌚ 1000H: REPLACE: AIR INTAKE LINE AND AIR SUCTION OUTLET HOSE.*

Note: the safety strut is put in place. The battery cover is removed. The engine grid is removed. The left-hand turntable cover is open.

- Clean the outside of the air filter unit ① with a clean, slightly damp cloth.
- Unlock and remove the cover ②.
- Clean the inside of the cover with a clean, slightly damp cloth.
- Remove the valve ③ and clean it with a clean, slightly damp cloth.
- Check the condition and replace it if it is damaged.
- Put the valve back in place.
- Remove the used outside air filter cartridge ④, pulling it gently to prevent dust dispersion.

Note: do not press the center of the outside air filter cartridge.

- Check the condition of the inside air filter cartridge ⑤ without taking it out.
- Check the condition of the air filter unit, the air intake line, the air suction outlet hose and the tightening clamps.
- Replace the outside air filter cartridge ④, ⚠ FILTER CARTRIDGES AND BELTS:
  - Clean the seal of the new outside air filter cartridge with a clean cloth.
  - Put the new outside air filter cartridge in place by pushing it gently.

Note: do not press the center of the outside air filter cartridge.

- Refit the cover ②, with the valve ③ facing downward and the marking "TOP" facing upward.

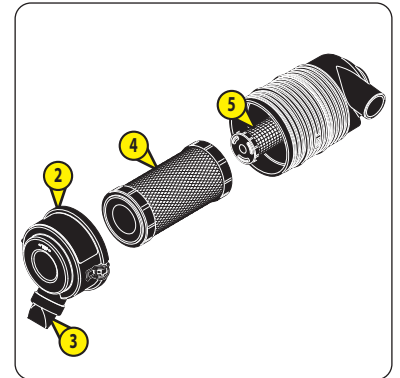
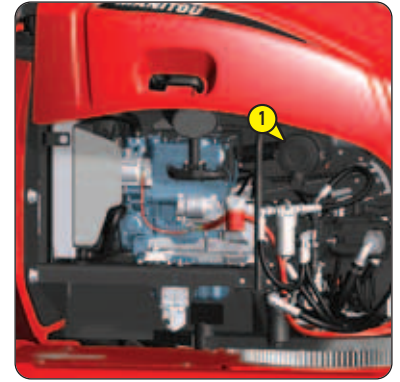

## REPLACE

## Turntable rotation motor oil

### ⚠ IMPORTANT ⚠

*It is recommended that the oil is slightly warm before being changed.*

Note: the safety strut is put in place. The battery cover is removed. The engine grid is removed. The left-hand turntable cover is open.

### DRAIN THE OIL

- Place a drain pan under the drain plug ①.
- Remove the drain plug and the filler plug ②.
- Wait until the crankcase is completely empty.

### FILL THE TURNTABLE ROTATION MOTOR

- Clean around the drain hole with a clean cloth.
- Refit the drain plug.
- Fill the turntable rotation motor with new oil, <img alt="oil can icon" data-bbox="395 250 410 265"/> LUBRICANTS, COOLANT AND FUEL.
- Clean the dipstick on the filler cap with a clean cloth and put it back in place.
- Remove the filler cap. The level is correct when the oil is between the 2 marks A and B.
- If the level is low, add oil until the correct level is reached, <img alt="oil can icon" data-bbox="395 310 410 325"/> LUBRICANTS, COOLANT AND FUEL.
- Refit the filler cap.
- Put the engine grille ③ back in place.
- Put the battery cover ④ back in place.
- Remove the safety strut, <img alt="oil can icon" data-bbox="395 385 410 400"/> OCCASIONAL OPERATIONS.

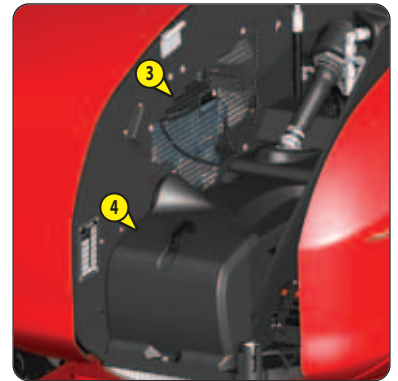
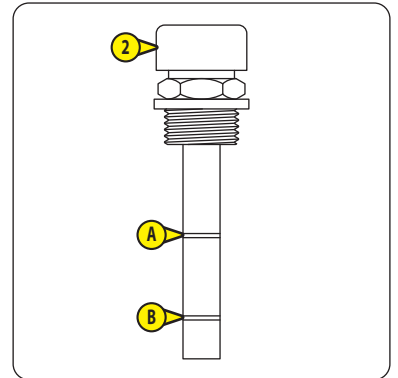
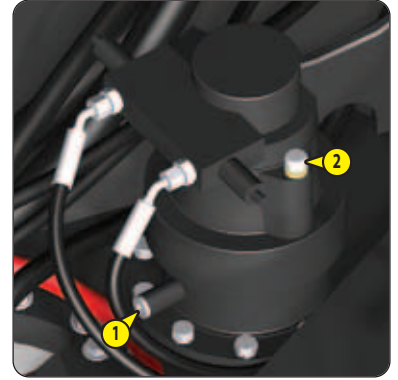

## REPLACE

## Hydraulic pressure filter cartridge

### ⚠ IMPORTANT ⚠

*Never use the machine without the hydraulic pressure filter cartridge or if it is damaged.*

Note: the left-hand turntable cover is open.

- Clean the outside of the hydraulic pressure filter ① with a clean cloth.
- Place a drain pan underneath.
- Replace the hydraulic pressure filter cartridge ②, <img alt="oil can icon" data-bbox="415 705 430 720"/> FILTER CARTRIDGES AND BELTS:
  - Unscrew the hydraulic pressure filter tank ③.
  - Remove the used hydraulic pressure filter cartridge.
  - Put the new hydraulic pressure filter cartridge in place.
  - Put the hydraulic pressure filter tank back in place.
- Start the diesel engine.
- Lift/lower the main arm, the secondary arm and the jib arm for several minutes.
- Fully lower the main arm, the secondary arm and the jib arm.
- Check for leaks.
- Switch off the machine.

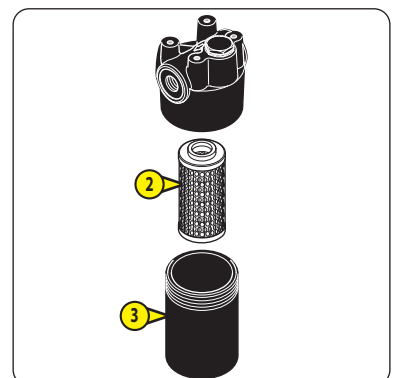
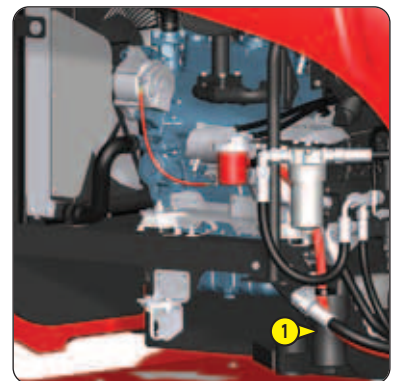

647909 (A112020)  
160 ATJ 4RD ST5 S2 / 160 ATJ RC 4RD ST5 S2  
180 ATJ 4RD ST5 S2 / 180 ATJ RC 4RD ST5 S2



## REPLACE

## Hydrostatic transmission filter cartridge

### ⚠ IMPORTANT ⚠

*Never use the machine without the hydrostatic transmission filter cartridge or if it is damaged.*

Note: the left-hand turntable cover is open.

- Clean the outside of the hydrostatic transmission filter **1** with a clean cloth.
- Place a drain pan underneath.
- Replace the hydrostatic transmission filter cartridge **2**,  FILTER CARTRIDGES AND BELTS:
  - Unscrew the hydrostatic transmission filter tank **3**.
  - Remove the used hydrostatic transmission filter cartridge.
  - Put the new hydrostatic transmission filter cartridge in place.
  - Put the hydrostatic transmission filter tank back in place.
- Close the left-hand turntable cover.
- Start the diesel engine.
- Drive the machine forward and backward for several minutes.
- Open the left-hand turntable cover.
- Check for leaks.
- Check the hydraulic oil level,  DAILY MAINTENANCE: CHECK THE HYDRAULIC OIL LEVEL.
- Close the left-hand turntable cover.
- Switch off the machine.

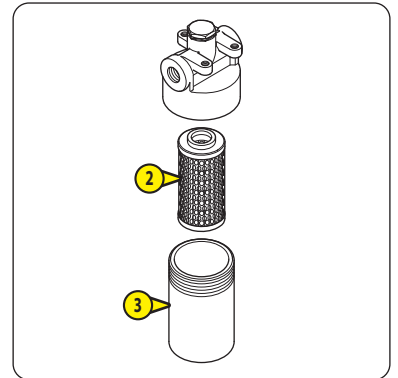
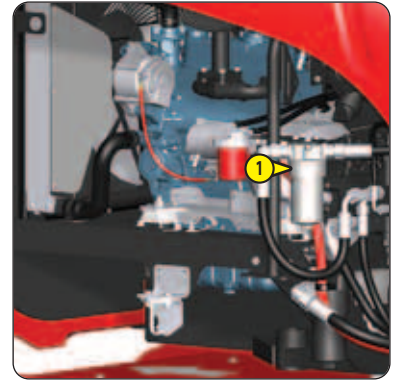

## RESET

## Maintenance warning

-   250H: RESET: MAINTENANCE WARNING.

## ➔ ③ 1000H - PERIODIC MAINTENANCE - EVERY 1,000 HOURS OF SERVICE OR 2 YEARS

ALSO PERFORM THE DAILY SERVICE AND THE PERIODIC SERVICES AT 250 HOURS AND 500 HOURS OF SERVICE.

### CLEAN

### Fuel tank

#### ⚠ IMPORTANT ⚠

*No flames or sparks. Do not smoke during cleaning.*

- Start the diesel engine.
- Turn the turntable 90° to the right.
- Switch off the machine.
- Locate the drain plug ① under the counterweight and put a drain pan underneath.
- Remove the drain plug and the tank plug ②.
- Wait until the tank is completely empty.
- Rinse the tank with 10 liters of clean fuel, <math>\leftarrow</math> LUBRICANTS, COOLANT AND FUEL.
- Clean around the drain hole with a clean cloth.
- Refit the drain plug.
- Fill the tank completely with clean fuel, <math>\leftarrow</math> DAILY MAINTENANCE: CHECK FUEL LEVEL.
- Refit the tank cap.
- Bleed the fuel supply circuit <math>\leftarrow</math> OCCASIONAL MAINTENANCE.
- Start the diesel engine.
- Put the turntable in neutral position.
- Switch off the machine.



### REPLACE

### Inside air filter cartridge

#### ⚠ IMPORTANT ⚠

*Never use the machine without the inside air filter cartridge or if it is damaged.*

- Open the left-hand turntable cover.
- Perform the procedure described in ➔ ② 500H: REPLACE THE OUTSIDE AIR FILTER CARTRIDGE and replace the inside air filter cartridge ⑤, <math>\leftarrow</math> FILTER CARTRIDGES AND BELTS:
  - Remove the used inside air filter cartridge, pulling it gently to prevent dust dispersion.
  - Block the outlet of the air filter unit with a clean cloth.
  - Clean the inside of the air filter unit with a clean, slightly damp cloth.
  - Remove the cloth from the air filter unit outlet.
  - Clean the seal of the new inside air filter cartridge with a clean cloth.
  - Put the new inside air filter safety cartridge in place by pushing it gently.

Note: do not press the center of the inside air filter cartridge.

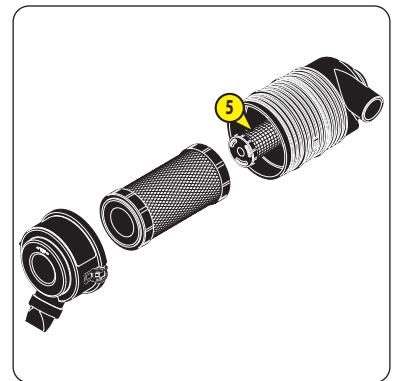

**⚠ IMPORTANT ⚠**

*Wait until the diesel engine cools if it has been running for a while.  
Do not remove the radiator cap until the diesel engine is completely cooled.*

Note: the left-hand turntable cover is open.

**DRAIN THE COOLANT**

- Locate the drain plug **1** under the coolant radiator and put a drain pan underneath.
- Locate the drain tap **2** and put a drain pan underneath.
- Close the drain tap.
- Remove the drain plug and the radiator cap **3**.
- Wait until the cooling circuit is completely empty.

**FILL THE COOLING CIRCUIT**

- Close the drain valve.
- Clean around the drain hole with a clean cloth.
- Refit the drain plug.
- Fill the cooling circuit with new coolant,  $\triangleleft$  LUBRICANTS, COOLANT AND FUEL. The level is correct when the coolant reaches the top of the filling hole.
- Refit the radiator cap.
- Start the diesel engine.
- Allow it to idle for 5 minutes.
- Check for leaks.
- Switch off the machine.
- Wait until the diesel engine cools.
- Remove the radiator plug .
- Check the coolant level and top up if necessary.
- Refit the radiator cap.
- Close the left-hand turntable cover.

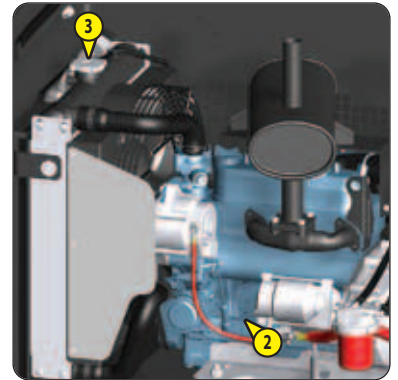
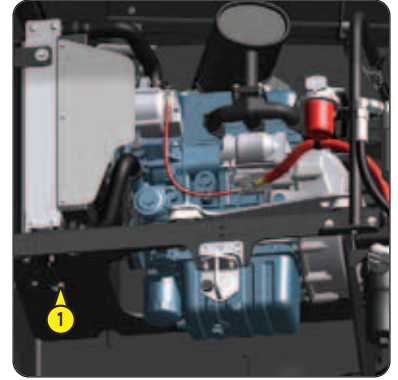

**⚠ IMPORTANT ⚠**

*It is recommended that the oil is slightly warm before being changed.*

**CHANGE THE OIL**

- Locate the reduction gearbox **1** on the rear axle.
- Clean the outside of the reduction gearbox with a clean cloth.
- Place a drain pan under the drain plug **2**.
- Remove the drain plug and the filler plug **3**.
- Wait until the reduction gearbox is completely empty.

**FILL THE ENGINE REDUCTION GEARBOX**

- Clean around the drain hole with a clean cloth.
- Refit the drain plug.
- Fill the reduction gearbox with new oil,  $\triangleleft$  LUBRICANTS, COOLANT AND FUEL. The level is correct when the oil reaches the rim of the filling hole.
- Refit the filler cap.

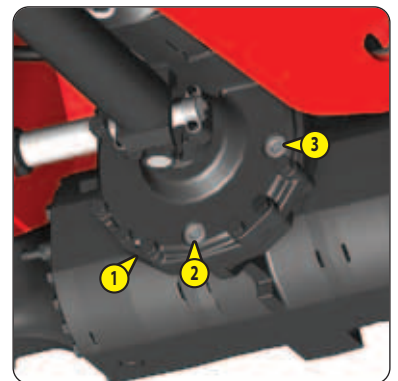

## REPLACE

### Front and rear axle differential oil

#### ⚠ IMPORTANT ⚠

*It is recommended that the oil is slightly warm before being changed.*

Note: replace the oil in the axle differentials one by one.

#### CHANGE THE OIL

- Clean the outside of the axle differential with a clean cloth.
- Front axle: place a drain pan under the drain plug ①.
- Rear axle: place a drain pan under the 3 drain plugs ①.
- Remove the drain plug(s) and the filler plug ②.
- Wait until the axle differential is completely empty.

#### FILL THE AXLE DIFFERENTIAL

- Clean around the drain hole(s) with a clean cloth.
- Front axle: refit the drain plug.
- Rear axle: refit the 3 drain plugs.
- Fill the axle differential with new oil, ⚠ LUBRICANTS, COOLANT AND FUEL. The level is correct when the oil reaches the rim of the filling hole.
- Refit the filler cap.

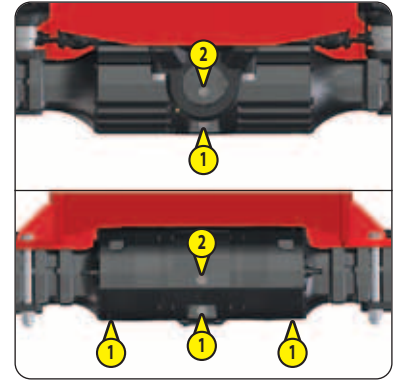

## REPLACE

### Front and rear wheel reduction gear oil

#### ⚠ IMPORTANT ⚠

*It is recommended that the oil is slightly warm before being changed.*

Note: replace the oil in the wheel reduction gears one by one.

#### CHANGE THE OIL

- Clean the outside of the wheel reduction gear with a clean cloth.
- Turn the wheel to put the drain/filler plug ① in position ②.
- Place a drain pan underneath.
- Remove the drain/filler plug.
- Wait until the wheel reduction gear is completely empty.

#### FILL THE WHEEL REDUCTION GEAR

- Clean around the drain/filler hole with a clean cloth.
- Turn the wheel to put the drain/filler hole ① in position ②.
- Fill the wheel reduction gear with new oil, ⚠ LUBRICANTS, COOLANT AND FUEL. The level is correct when the oil reaches the rim of the filling hole.
- Refit the drain/filler plug:
  - Tightening torque = 42 N.m ± 7 N.m

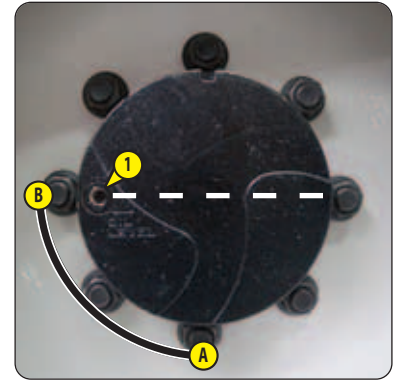

**⚠ IMPORTANT ⚠**

*It is recommended that the oil is slightly warm before being changed.*

*There can be a difference in level between hot and cold oil. It is recommended the level is checked again when the hydraulic oil is hot.*

*Clean the oil can before adding oil to the hydraulic oil tank.*

*Use a clean funnel to add oil to the hydraulic oil tank.*

**CHANGE THE OIL**

- Put the safety strut in place, ⚠ OCCASIONAL OPERATIONS.
- Remove the battery cover ①.
- Open the right-hand turntable cover.
- Locate the drain plug ② and put a drain pan underneath.
- Remove the drain plug and the tank plug ③.
- Wait until the tank is completely empty.

**CLEAN THE FILLING FILTER AND SUCTION STRAINER**

- Remove the filling filter ④.
- Clean it with compressed air, from the outside in:
  - Maximum pressure = 3 bars. Minimum distance = 30 mm.
- Check its condition. Replace it if necessary, ⚠ FILTER CARTRIDGES AND BELTS.
- Place a drain pan under the hydraulic pipe ⑤.
- Remove the hydraulic pipe and the suction strainer ⑥.
- Clean the suction strainer with compressed air, from the inside out:
  - Maximum pressure = 3 bars. Minimum distance = 30 mm.
- Check its condition. Replace it if necessary, ⚠ FILTER CARTRIDGES AND BELTS.
- Check that there is no debris or dust in the bottom of the tank. Clean it if necessary.
- Refit the filling filter.
- Refit the suction strainer and the hydraulic pipe.

**FILL THE HYDRAULIC OIL TANK**

- Refit the drain plug.
- Fill the tank with new hydraulic oil, ⚠ LUBRICANTS, COOLANT AND FUEL. The level is correct when the oil reaches the bottom of the level indicator ⑦.

Note: the hydraulic oil must not reach the red dot on the level indicator because the secondary arm is slightly raised with the safety strut in place.

- Refit the tank cap.
- Put the battery cover ① back in place.
- Remove the safety strut, ⚠ OCCASIONAL OPERATIONS.
- Start the diesel engine.
- Activate the machine's functions for 10 minutes.
- Check for leaks.
- Place the machine in transport position.
- Put the turntable and the platform in neutral position.
- Level the platform/jib arm.
- Fully lower the jib arm.
- Check the hydraulic oil level and top up if necessary, ⚠ DAILY MAINTENANCE: CHECK HYDRAULIC OIL LEVEL.
- Close the right-hand turntable cover.
- Switch off the machine.

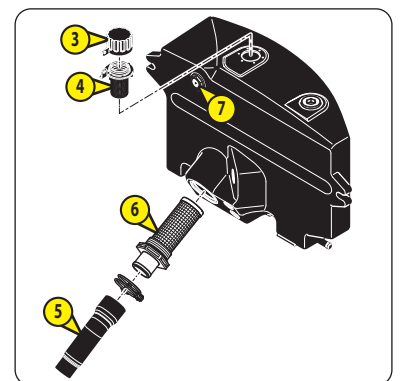
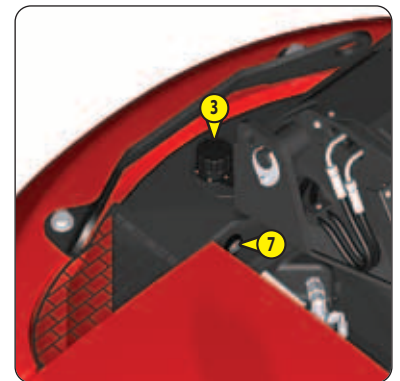
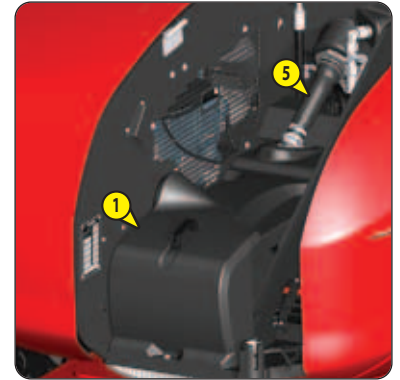

<b>CHECK</b>	<b><i>Diesel engine silent blocks *</i></b>
<b>CHECK</b>	<b><i>Diesel engine speeds *</i></b>
<b>CHECK</b>	<b><i>Valve lash *</i></b>
<b>CHECK</b>	<b><i>Injectors *</i></b>
<b>CHECK</b>	<b><i>Hydrostatic transmission circuit pressure *</i></b>
<b>CHECK</b>	<b><i>Clearance of slewing ring gear *</i></b>
<b>CHECK</b>	<b><i>Speeds of hydraulic movements *</i></b>
<b>CHECK</b>	<b><i>Condition of cylinders *</i></b>
<b>CHECK</b>	<b><i>Condition of electric wiring *</i></b>
<b>REPLACE</b>	<b><i>Air intake line and air suction hose *</i></b>
<b>REPLACE</b>	<b><i>Hoses and hose clamps for the coolant radiator *</i></b>
<b>REPLACE</b>	<b><i>Injection pipes, fuel hoses and the hose clamps *</i></b>
<b>RESET</b>	<b><i>Maintenance warning</i></b>

⚠️ 250H: RESET: MAINTENANCE WARNING.

*\* Consult your dealer.*

## ➔ ④ 2000H - PERIODIC MAINTENANCE - EVERY 2,000 HOURS OF SERVICE OR 4 YEARS

ALSO PERFORM THE DAILY SERVICE AND THE PERIODIC SERVICES AT 250 HOURS, 500 HOURS AND 1,000 HOURS OF SERVICE.

**CHECK** *Coolant and oil radiators \**

**CHECK** *Water pump and thermostat \**

**CHECK** *Injection pump \**

**CHECK** *Alternator and starter \**

**CHECK** *Hydraulic circuit pressures \**

**RESET** *Maintenance warning*

🔊 ➔ ④ 250H: RESET: MAINTENANCE WARNING.

*\* Consult your dealer.*

### REPLACE

### Wheels

#### ⚠ IMPORTANT ⚠

⚠ 2 - DESCRIPTION: SPECIFICATIONS and refer to the applicable stickers for information about the total weight of the machine and wheel load.

*When lifting the machine with a mechanical or hydraulic jack:*

- Always use a suitable jack for lifting the machine.
- Make sure that the 2 wheels on the opposite side to the lift are chocked.
- Position the jack near the wheel to be raised.
- Always use suitable jack stands to secure the raised machine.

#### ⚠ IMPORTANT ⚠

*Weight of a wheel OTR OUTRIGGER XT 33X12 D610 NHS = 121 kg (267 lbs).*

*Weight of a wheel OTR OUTRIGGER XT 36X15 D610 NHS = 195 kg (430 lbs).*

- Loosen the wheel nuts slightly.
- Lift the machine.
- Remove the wheel nuts and the wheel.
- Put the new wheel in place.
- Refit the wheel nuts and tighten them slightly with a spanner.
- Lower the machine to the ground.
- Tighten the wheel nuts, ⚠ ⇒ 250H: CHECK: WHEEL NUT TIGHTENING.



**⚠ IMPORTANT ⚠**

Ensure that the machine is switched off.  
Disconnect the battery before working on the electrical system.

**POWER CIRCUIT FUSES**

- Open the left-hand turntable cover.
- Locate the fuse box ①.
- Remove the cover of the fuse box.
- Lift up the protective cover ②.
- Replace the appropriate fuse:

Ⓐ	Electric backup pump power supply	250 A fuse
Ⓑ	General electrical power supply	350 A fuse

Note: ⚡ STICKERS: POWER FUSES ③.

- Put the protective cover ② back in place.
- Put the fuse box cover back in place.
- Close the right-hand turntable cover.

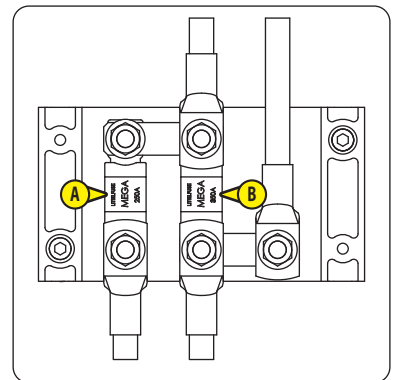
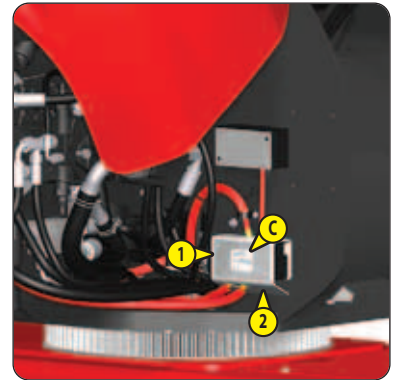

**DIESEL ENGINE FUSES/RELAYS AND CONTROL SYSTEM**

- Open the left-hand turntable cover.
- Locate the fuse/relay box ③.
- Remove the cover of the fuse/relay box.
- Replace the appropriate fuse/relay:

Ⓕ	Diesel engine preheat	60 A fuse
Ⓖ	Ground level control panel	60 A fuse
Ⓕ	Immobilizer (option)	1 A fuse
Ⓚ	Diesel engine preheat	12 V 40 A relay

- Put the fuse/relay box cover back in place.
- Close the left-hand turntable cover.

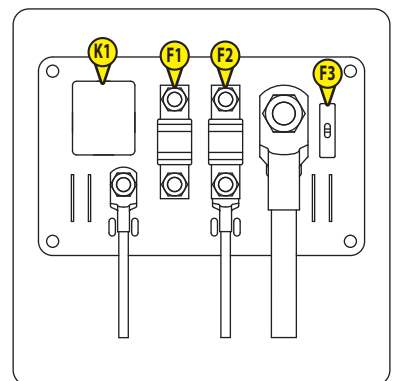
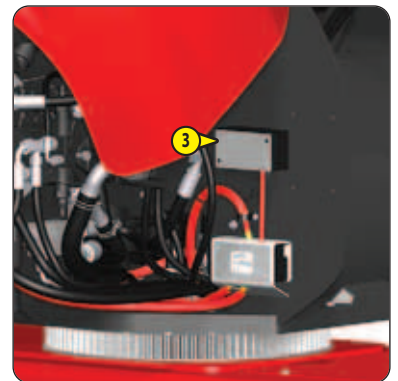

## GROUND LEVEL CONTROL PANEL FUSES/RELAYS

- Open the right-hand turntable cover.
- Unlock and open the ground level control panel 4.
- Replace the appropriate fuse/relay:



F1	Start button	5 A fuse
F2	Ground level display screen	5 A fuse
F3	Ground level display screen and control panel in the platform	5 A fuse
F4	Worklight power supply (option)	5 A fuse
F5	Backup pump button	10 A fuse
F6	Ground level display screen	5 A fuse
F7	Key switch	10 A fuse
F8	Diesel engine power supply	30 A fuse
K1	Immobilizer (option)	12 V 35 A relay
K2	Diesel engine stop	12 V 35 A relay
K3	General electrical power supply	12 V 35 A Relay

- Close the ground level control panel.
- Close the right-hand turntable cover.

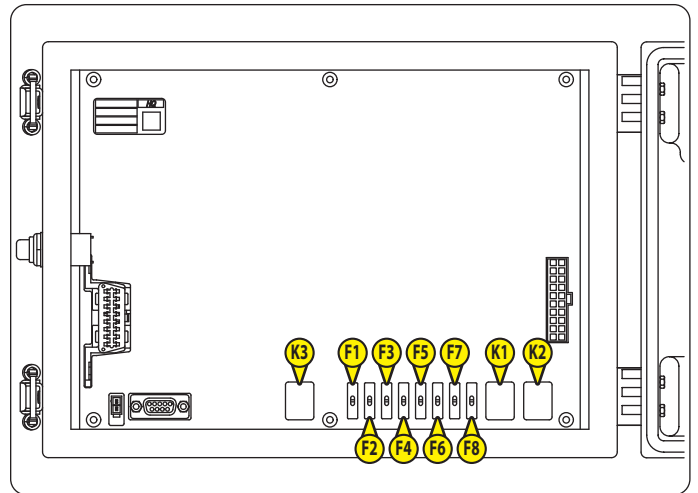

**⚠ IMPORTANT ⚠**

*Never smoke or approach with a flame when the fuel supply circuit is being bled.*

*Always bleed the fuel supply circuit when:*

- *The fuel tank has been drained and then filled.*
- *There has been a fuel breakdown and then the fuel tank has been filled.*
- *A component of the fuel supply circuit has been cleaned or replaced.*

*If the diesel engine runs irregularly or stops after bleeding the fuel supply circuit, check the condition of the entire fuel supply circuit.*

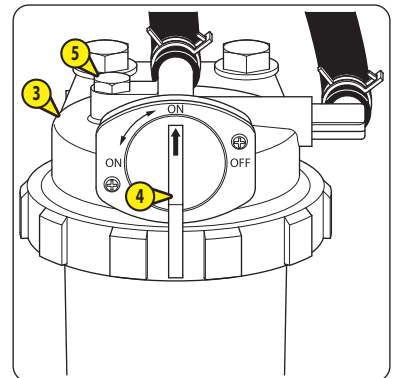
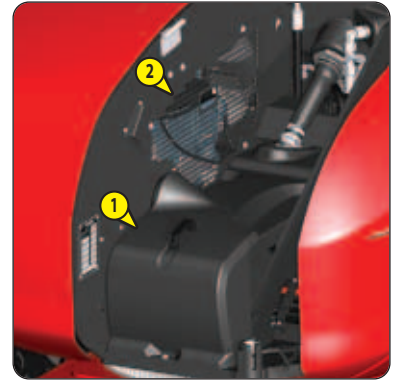
**BLEED THE FUEL FILTER**

- Put the safety strut in place, ⚠ OCCASIONAL OPERATIONS.
- Remove the battery cover (1).
- Remove the engine grille (2).
- Open the left-hand turntable cover.
- Place a drain pan under the fuel filter (3).
- Turn the tap (4) to the ON position "ON".
- Unscrew the bleeder screw (5).
- Locate the fuel pump (6).
- Action the manual pump (7) until fuel runs out of the bleeder screw.
- Continue pumping and tighten the bleeder screw.

**BLEED THE INJECTION PUMP**

- Locate the bleeder screw (8) and put a drain pan underneath.
- Unscrew bleeder screw.
- Action the manual pump (7) until fuel runs out of the bleeder screw.
- Continue pumping and tighten the bleeder screw.
- Start the diesel engine.
- Allow it to idle for 5 minutes.
- Check for leaks.
- Switch off the machine.
- Close the left-hand turntable cover.
- Put the engine grille (2) back in place.
- Put the battery cover (1) back in place.
- Remove the safety strut, ⚠ OCCASIONAL OPERATIONS.

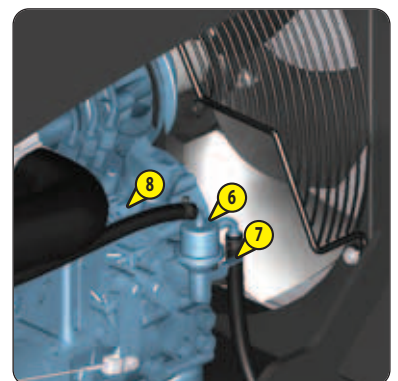

### USE

### Safety strut

#### ⚠ IMPORTANT ⚠

*Always put the safety strut in place when you need to carry out a maintenance operation under the raised secondary arm.*

*If you consider there is not enough space to work with the safety strut in place:*

*- Raise the secondary jib.*

*- Secure the secondary arm with a suitable lifting device.*

Note: the illustrations show a 160 ATJ.

#### PUT THE SAFETY STRUT IN PLACE

- Locate the safety strut ①.
- Remove the nut and the washer ②.
- Start the diesel engine.
- Raise the secondary jib at least 1 meter.
- Raise the safety strut and lock it using the stop Ⓐ.
- Lower the secondary arm until it stops on the safety strut.
- Switch off the machine.

#### REMOVE THE SAFETY STRUT

- Start the diesel engine.
- Raise the secondary arm slightly.
- Lower the safety strut.
- Fully lower the secondary arm.
- Refit the nut and the washer ②.
- Switch off the machine.

