



647816EN-USM1D082025

260 TJP ST5 S1
280 TJ ST5 S1

OPERATOR'S MANUAL
(ORIGINAL MANUAL)

INITIAL VERSION	A022021	
UPDATED	B112022	UKCA
	C022025	0-0 1-1 – 1-18 2-12 ; 2-14 – 2-17 ; 2-23 3-11 ; 3-13 ; 3-58
	D082025	0-0 2-66

This brochure is provided for information purposes only. Any reproduction, copy, declaration, recording, transfer, distribution or other, in whole or in part, in any format whatsoever, is prohibited. The plans, drawings, views, comments and instructions, as well as the organization of the document, are the intellectual property of MANITOU BF. Any violation of the aforementioned may lead to civil and criminal prosecution. The logos as well as the visual identity of the company belong to MANITOU BF and may not be used without express and formal authorization. All rights reserved.

Clause regarding database usage restrictions

Connected Manitou machines are equipped with boxes that collect technical data on the machines (such as geo-tracking data or data on component operation). This data, which is organized, processed and enhanced by algorithms and expertise proprietary to Manitou, constitutes a protected database under article L.341-1 of the Intellectual Property Code.

It is strictly forbidden to have access to all or part of this database and to use the data (including in the event of accidental access) without explicit prior authorization from Manitou. In the event that Manitou authorizes a Manitou machine user to access all or part of this database, Manitou, as producer of this database, cedes to the user only a right to personal, non-exclusive, nontransferable use of the database, and only by access to an information technology platform hosted by a server owned or controlled by Manitou.

In any case, the following are strictly prohibited:

- any extraction, reproduction, representation, reuse through provision to the public, distribution, transfer, permanent or temporary, on any medium, by any means, and in any form whatsoever, of all or of a qualitatively or quantitatively substantial part of the contents of this database.*
- any extraction, reproduction, representation, reuse through provision to the public, distribution, transfer, repeated or systematic of qualitatively or quantitatively insubstantial parts of the content of the database during operations manifestly exceeding normal use of the database by the user of the machine for his own needs,*
- any use of means to bypass technical protection measures for databases or software source code embedded in the boxes, in keeping with article L.331-5 of the Intellectual Property Code.*

FOREWORD

ABOUT THIS OPERATOR'S MANUAL

This operator's manual forms an integral part of this machine and must be kept in the platform's storage compartment at all times.

MANITOU reserves the right to change its models and their equipment without notice. Contact MANITOU for up-to-date information.

This operator's manual provides operators with all the information relating to the safety precautions, usage instructions and maintenance procedures to ensure safe and reliable use of this machine.

Carefully read and understand this instruction manual before using this machine.

This manual has been produced based on the equipment list and technical specifications given at the time of its design. The level of equipment depends on the options chosen and the country of sale.

According to the options and the date of sale, certain items of equipment/functions described in this operator's manual may not be present on the machine.

Descriptions and illustrations are non binding.

ANTICIPATED USE

This machine is a mobile aerial work platform of the type 3b designed to transport and lift personnel and their tools and equipment to a workplace at height.

MANITOU has ensured that this machine is suitable for use in the standard operating conditions defined in this operator's manual.

TECHNICAL INFORMATION BULLETINS

The safety of the machine and personnel is essential for MANITOU. The technical information bulletins are written to communicate important safety information, intended for dealers, owners and users of the machine.

This machine must comply with all the relevant technical information bulletins. Contact MANITOU or your dealer to get information on the bulletins concerning your machine.

These technical information bulletins are sent to the owners of the machine. As a result, it is very important to register your machine and ensure that the information is accurate and up to date.

In the event of transfer of ownership of the machine, update the information to guarantee that the technical information bulletins are sent to the new owner.

CONTACT THE MANUFACTURER

You should contact MANITOU in the following scenarios:

- To report an accident.
- To update the information relating to the current owner.
- For questions about compliance with standards and regulations.
- For questions about machine use and safety.
- For questions about any special application or any modification of the product.

Manitou BF SA Limited liability company with a Board of Directors.

Headquarters: 430 rue de l'Aubinière - 44150 Ancenis - France

Share capital: 39 548 949 €

857 802 508 RCS Nantes

Tel.: +33 (0) 2 40 09 10 11

www.manitou.com

WARNINGS AND SAFETY INSTRUCTIONS

The following safety alert is used in this manual to warn you of the risks during use or maintenance of this machine:



Follow the safety instructions following this warning to avoid any risk of injury, death or equipment damage.

IDENTIFICATION OF THE MACHINE

The machine's identification plate is riveted to the chassis at the rear of the machine. The following information is engraved on it:

"Designation" Designation	
"Year of manufacture" Year of manufacture	
"Model year" Model year	
"Unladen mass" Unladen weight	
"Nominal power" Nominal power	
"Voltage" Voltage	
"Inside / Outside" Interior/Exterior	
"Maximum load" Maximum load	
"Maximum number of persons" Maximum number of people	
"Mass of equipment" Equipment weight	
"Manual forces" Manual forces	
"Maximum inclination" Maximum tilt	
"Maximum wind speed" Maximum wind speed	
"Serial Number" Serial number	



Note: commercial names are used in this operator's manual in order to make it easier to read.

260 TJP ST5 S1

Commercial name: 260 TJ+



280 TJ ST5 S1

Commercial name: 280 TJ



SECTIONS

- 1 - OPERATING AND SAFETY INSTRUCTIONS**
- 2 - DESCRIPTION**
- 3 - MAINTENANCE**
- 4 - ATTACHMENTS**

1 - OPERATING AND SAFETY INSTRUCTIONS

1 - OPERATING AND SAFETY INSTRUCTIONS

INSTRUCTIONS TO THE COMPANY MANAGER

1-4

THE SITE	1-4
THE OPERATOR	1-4
THE MACHINE	1-4
A - SUITABILITY OF THE MACHINE FOR THE TASK	1-4
B - ADAPTING THE MACHINE TO USUAL ENVIRONMENTAL CONDITIONS	1-5
C - MODIFYING THE MACHINE	1-5
INSTRUCTIONS	1-5
MAINTENANCE	1-5

INSTRUCTIONS FOR THE OPERATOR

1-6

INTRODUCTION	1-6
GENERAL INSTRUCTIONS	1-6
A - OPERATOR'S MANUAL	1-6
B - AUTHORISATION FOR USE IN FRANCE	1-6
C - MAINTENANCE	1-7
D - MODIFYING THE MACHINE	1-7
E - GROUND LINK	1-7
F - SAFETY DEVICES	1-7
OPERATING INSTRUCTIONS	1-8
A - BEFORE USING THE MACHINE	1-8
B - DRIVER'S CAB LAYOUT	1-8
C - ENVIRONMENT	1-9
D - VISIBILITY	1-10
E - STARTING MACHINES WITH A DIESEL ENGINE	1-11
F - SWITCHING ON ELECTRICAL MACHINES	1-11
G - DRIVING THE MACHINE	1-11
H - SHUTTING DOWN THE MACHINE	1-12
INSTRUCTIONS FOR WELDING AND BLOW TORCH WORK ON AN EXTERNAL STRUCTURE	1-13
A - WITH AN ELECTRICAL WELDING SET	1-13
B - WITH A BLOW TORCH	1-13

MACHINE MAINTENANCE INSTRUCTIONS

1-14

GENERAL INSTRUCTIONS	1-14
MAINTENANCE	1-14
MAINTENANCE LOGBOOK	1-14
LUBRICANT AND FUEL LEVELS	1-14
HYDRAULICS	1-14
ELECTRICITY	1-15
TILT SENSOR	1-15
WELDING ON THE MACHINE	1-15
WASHING THE MACHINE	1-15

IF THE MACHINE IS NOT TO BE USED FOR A LONG TIME **1-16**

INTRODUCTION 1-16

PREPARATION OF THE MACHINE 1-16

MACHINES WITH A DIESEL ENGINE: ENGINE PROTECTION 1-16

ELECTRICAL MACHINES: BATTERY CHARGE 1-16

PROTECTING THE MACHINE 1-16

BRINGING THE MACHINE BACK INTO SERVICE. 1-17

DISPOSING OF THE MACHINE **1-18**

RECYCLING OF MATERIALS 1-18

METALS 1-18

PLASTICS 1-18

RUBBER 1-18

GLASS 1-18

ENVIRONMENTAL PROTECTION 1-18

WORN OR DAMAGED PARTS 1-18

USED OIL 1-18

USED BATTERIES. 1-18

INSTRUCTIONS TO THE COMPANY MANAGER

THE SITE

Proper management of the machine's area of travel will reduce the risk of accidents:

- Ground not unnecessarily uneven or obstructed.
- No excessive slopes.
- Pedestrian traffic controlled, etc.

THE OPERATOR

⚠ IMPORTANT ⚠

Only qualified, authorised personnel can use this machine.

This authorisation is given in writing by the appropriate person in the establishment with respect to the use of machine and must be carried permanently by the operator.

⚠ IMPORTANT ⚠

On the basis of experience, there are a number of possible situations in which operating the machine is contra-indicated.

Such foreseeable abnormal uses, the main ones being listed below, are strictly forbidden:

- *The foreseeable abnormal behaviour resulting from ordinary negligence, but which does not result from any wish to put the machinery to any improper use.*
 - *The reflex reactions of a person in the event of a malfunction, incident, fault, etc. during operation of the machine.*
 - *Behaviour resulting from application of the "principle of least effort" when performing a task.*
- *The foreseeable behaviour of such persons as: apprentices, teenagers, handicapped persons, trainees tempted to drive a machine, operators tempted to operate a machine to win a bet, in competition or for their own personal experience.*
 - *The person in charge of the establishment must take these criteria into account when assessing the suitability of a person to drive.*

⚠ IMPORTANT ⚠

OBTAIN INFORMATION ON:

- *How to behave when there is a fire.*
- *The location of the nearest first aid kit and fire extinguisher.*
- *The emergency telephone numbers for calling (the doctors, ambulance, hospital and fire brigade).*

THE MACHINE

A - SUITABILITY OF THE MACHINE FOR THE TASK

- MANITOU has ensured that this machine is suitable for use under the standard operating conditions defined in this operator's manual, with an **OVERLOAD TEST COEFFICIENT OF 1.25** and an **OPERATIONAL TEST COEFFICIENT OF 1.1**, as stipulated in harmonised standard **EN 280** for **MEWPs** (Mobile Elevating Work Platforms).
- Before commissioning, the company manager must make sure that machine is appropriate for the work to be done, and perform certain tests (in accordance with current legislation).

B - ADAPTING THE MACHINE TO USUAL ENVIRONMENTAL CONDITIONS



For operation under average climatic conditions, i.e.: between -15 °C and +35 °C, lubricants are topped up in the factory.

For operation under more severe climatic conditions, before starting up, it is necessary to drain all the circuits, then ensure correct levels of lubricants using lubricants properly suited to the relevant ambient temperatures. The same applies to coolant.



Machines with diesel engines are designed for outdoor use under normal atmospheric conditions and indoor use in suitably aerated and ventilated premises.

Electrical machines are designed for outdoor use under normal atmospheric conditions and for indoor use.

It is prohibited to use the machine in areas where there is a risk of fire or which are potentially explosive (e.g. refineries, fuel or gas depots, stores of inflammable products, etc.).

For use in these areas, specific equipment is available, consult your dealer.

- In addition to standard equipment mounted on your machine, many options are available, such as: rotating beacon light, worklight, etc. Contact your dealer.
- Take the climate and atmospheric conditions of the site of use into account. Consult your dealer for adapting the lubricants and frost protection.
- Prevent fire risks associated with use in dusty and flammable conditions.
- A machine operating in an area without fire extinguishing equipment must be equipped with an individual extinguisher. Solutions are available, consult your dealer.

C - MODIFYING THE MACHINE



It is strictly prohibited to replace machine components with components not approved by Manitou (batteries, wheels, platform, etc.).



It is strictly forbidden to change the structure and settings of the various components of your machine (hydraulic pressure, calibrating limiters, engine speed, sensors, addition of extra equipment, addition of counterweight, unapproved attachments, alarm systems, etc.) yourself. In this event, the manufacturer cannot be held responsible.



Risk of the machine becoming unstable:

- *Depending on the model, your machine may be supplied with standard wheels or all-terrain wheels. It is PROHIBITED to change from one type of wheel to the other.*
- *ELECTRICAL MACHINES: it is prohibited to replace the batteries with lighter batteries.*

INSTRUCTIONS

- The instruction manual should always be in good condition, in the operator's language and placed in the platform storage compartment.
- You must replace the instruction manual, as well as any plates or stickers, if they are no longer legible or are missing or damaged.

MAINTENANCE



Refer to chapter: MACHINE MAINTENANCE INSTRUCTIONS.



Your machine must be periodically inspected to ensure its continued compliance.

The inspection frequency is defined by the legislation in force in the country in which the machine is used.

- Maintenance or repairs other than those detailed in section 3 - MAINTENANCE must be carried out by qualified personnel (consult your dealer) and under the necessary safety conditions to maintain the health of the operator and any third party.
- Example for France: the manager in charge of the establishment using a machine must open and maintain a maintenance log for each machine (order of 2 March 2004).

INSTRUCTIONS FOR THE OPERATOR

INTRODUCTION

⚠ IMPORTANT ⚠

The risk of accident while using, servicing or repairing this machine can be reduced if you follow the safety instructions and preventive measures detailed in these instructions.

Failure to respect the safety and operating instructions, or the instructions for repairing or servicing this machine may lead to serious, even fatal accidents.

- Only the operations and manoeuvres described in this operator's manual must be performed. The manufacturer cannot predict all possible risky situations. Consequently, the safety instructions given in the operator's manual and on the machine itself are not exhaustive.
- As an operator, you must at all times give reasonable consideration to the possible risks to yourself, to others or to the machine itself when you use it.

GENERAL INSTRUCTIONS

A – OPERATOR'S MANUAL

⚠ IMPORTANT ⚠

Carefully read and understand this instruction manual before using this machine.

- The instruction manual should always be in good condition, in the operator's language and placed in the platform storage compartment.
- You must replace the instruction manual, as well as any plates or stickers, if they are no longer legible or are missing or damaged.
- Any operations or manoeuvres not described in the operator's manual are forbidden.
- Follow the safety advice and the instructions on the machine's stickers.
- As a safety precaution, a user must be present on the ground when the machine is in use.
- Familiarise yourself with the machine on the terrain where it will be used.
- The machine must also be used in accordance with good engineering practice.
- Do not use the machine if the wind speed is over 45 km/h (12.5 m/s).
- Do not push or pull similar structures or elements off the platform. The maximum manual force is indicated in 2 - INSTRUCTIONS: SPECIFICATIONS and on 1 or more stickers located in the platform.
- Machines intended exclusively for indoor use must not be used outside the buildings.

B - AUTHORISATION FOR USE IN FRANCE

(or see current legislation in other countries).

- This machine is not type-approved for driving on public roads.
- Only qualified, authorised personnel can use the machine. This authorisation is given in writing by the appropriate person in the establishment where the machine is to be used and must be carried permanently by the operator.
- The operator is not empowered to authorise the driving of the machine by another person.

C - MAINTENANCE

⚠ IMPORTANT ⚠

Do not use the machine if the wheels are damaged or excessively worn, because this could put your own safety or that of others at risk, or cause damage to the machine itself.

⚠ IMPORTANT ⚠

For electrical machines, the operator must ensure that:

- Safety goggles are always worn when charging the batteries.

- The batteries are not charged in an explosive environment.

- There is no smoking and no naked flame directed towards the batteries when they are being handled (removal/installation) and when monitoring filling levels.

- Do not leave the battery charger connected during a lightning storm.

- The operator must carry out the daily maintenance (↖ 3 - MAINTENANCE) before using the machine in his place of work.
- The operator must immediately advise his superior if his machine is not in good working order or does not comply with the safety notice.
- The operator is prohibited from carrying out any repairs or adjustments himself, unless he has been trained for this purpose. He must keep the machine properly cleaned if this is among his responsibilities.
- The operator is responsible for deciding and adjusting the frequency of cleaning needed to prevent the risk of fire ensuing from the build-up of flammable material. The operator should pay special attention to all the areas of the machine where these risk materials are likely to accumulate.
- The operator must ensure that the wheels are appropriate for the type of ground (see the ground contact area of the wheels ↖ 2 - DESCRIPTION: SPECIFICATIONS). Optional solutions are available, consult your dealer.

D - MODIFYING THE MACHINE

- ↖ INSTRUCTIONS TO SITE MANAGER: ↖ C - MODIFYING THE MACHINE.

E - GROUND LINK

- MACHINES WITHOUT OSCILLATING AXLE (ACCORDING TO MODEL)

⚠ IMPORTANT ⚠

The frame is rigid, so the machine can bear on only three wheels.

- MACHINES WITH OSCILLATING AXLE (ACCORDING TO MODEL)

⚠ IMPORTANT ⚠

The oscillating axle enables the machine to bear on four wheels when in transport position (within the limits of the axle's oscillation).

When moving in the working position, the oscillating axle is locked (the frame is stiff) so the machine may bear on only three wheels.

F - SAFETY DEVICES

- This machine is fitted with special safety devices that are able to limit its operation as circumstances require (↖ 2 - DESCRIPTION):
 - Excessive load in the platform.
 - Tilting of the frame beyond the authorised limits.
 - Blocking of the oscillating axle (according to model).
 - Slack or broken telescope cable (according to model).

OPERATING INSTRUCTIONS

A - BEFORE USING THE MACHINE

- Perform the daily maintenance (↩ 3 - MAINTENANCE).

B - DRIVER'S CAB LAYOUT

- Whatever their experience, operators are advised to familiarise themselves with the position and operation of the control panels before putting the machine into operation.
- Do not get into or out of the platform until it is fully lowered.
- Always get into and out of the platform through the gate or using the sliding mid-rails (depending on the model).
- Always get in and out of the platform facing into the platform.
- Always use both hands and one foot or both feet and one hand to get in and out of the platform.
- Make sure that the sliding mid-rails (depending on the model) are in the low position and that the gate is closed properly (depending on the model) before using this machine.
- Do not attach the sliding mid-rails in the high position.
- MANITOU strongly recommends wearing a safety harness attached to a lashing point in the platform, ↩ 2 - DESCRIPTION. Wearing a safety harness or other personal fall protection may be mandatory, comply with the local, government and national regulations in force, the employer's safety rules and the rules for work sites.
- The safety harness or other personal fall protection must comply with the local, government and national regulations in force. They must be inspected in accordance with the regulations in force.
- Safety helmets must be worn.
- Wear suitable clothing for driving the machine; do not wear baggy clothes.
- Never operate the machine when hands or feet are wet or soiled with greasy substances.
- Make sure you have the appropriate protective equipment for the job to be done.
- Prolonged exposure to high noise levels may cause hearing problems. It is recommended to wear ear muffs to protect against excessive noise.
- Remain alert at all times when using the machine. Do not listen to the radio or music using headphones or earphones.
- The operator must always be in the normal operator's position. It is prohibited to have arms or legs, or generally any part of the body, protruding from the platform.
- The control units must never in any event be used for any other than their intended purposes (e.g. for getting in or out of the platform, as a coat hook, etc.).
- The machine must not be fitted with unauthorised attachments that increase the unit's wind load.
- Do not use ladders or improvised structures in the platform to gain extra height.
- Do not climb onto the platform railings to gain extra height.

C - ENVIRONMENT

⚠ IMPORTANT ⚠

If the platform must remain stationary over a structure for a long period, there is a risk that the platform will descend and rest on this structure because of the oil cooling in the cylinders or a minor leak in the cylinder locking system. To eliminate this risk:

- Regularly check the distance between the platform and the structure and readjust if necessary.
- If possible use the machine at an oil temperature as close as possible to ambient temperature.

⚠ IMPORTANT ⚠

*It is forbidden to use the machine close to electricity cables. Maintain the specified safe distances.
You must consult your local electrical agency.*

You could be electrocuted or seriously injured if you operate or park the machine too close to power cables.

If the machine comes into contact with electrical cables, press the Emergency Stop button.

Call for help, warn people on the ground not to touch the machine, and ask them to switch off or get somebody to switch off the power supply to the cables.

⚠ IMPORTANT ⚠

Do not use this machine during lightning storms, snow storms, during frosty periods or in hazardous weather conditions. In case of strong wind exceeding 45 km/h, do not make any movement that may endanger the machine's stability.

- Comply with site safety regulations.
- The machine can be manoeuvred from the ground: ensure that you forbid access.
- If you have to use the machine in a dark area or at night, make sure it is equipped with working lights.
- The machines may not be used as cranes or elevators for the permanent transport of people or materials, nor as jacks or supports.
- Suspending a load under the platform or on any part of the lifting apparatus is strictly forbidden.
- When operating, ensure that there is no one or anything impeding the machine's progress and operation.
- When raising the platform, ensure that nothing/nobody is impeding the machine's operation and do not perform any inappropriate manoeuvres.
- Do not allow anybody to come near the working area of the machine or pass beneath the lifting structure or beneath the platform. To ensure this, mark out your working area.
- Driving on a slope:
 - Adjust the machine speed with the proportional control handle.
 - Make sure that the slope is not steeper than the maximum slope for the machine (≪ 2 - DESCRIPTION).
- Take into account the machine's dimensions and its load before trying to negotiate a narrow or low passageway.
- Never move onto loading ramps without having first checked:
 - That they are suitably positioned and made fast.
 - That the vehicle to which it is connected (trailer, wagon, etc.) cannot move.
 - That they are suitable for the size and weight of the machine (≪ 2 - DESCRIPTION).
 - That the slope is not steeper than the maximum slope for the machine (≪ 2 - DESCRIPTION).
- Never move onto a foot bridge, floor or freight lift without being certain that they are suitable for the size and weight of the machine and without having checked that they are in sound working order.
- Be careful in the area of loading bays, trenches, scaffolding, soft ground, manholes, etc.
- Make sure the ground is stable and firm under the wheels and/or stabilisers before lifting the platform. If necessary, add sufficient wedging under the stabilisers.
- Do not attempt any operations outside the machine's capabilities.
- Ensure that any equipment and materials loaded onto the platform (pipes, cables, containers, etc.) cannot fall out. Do not pile this equipment and these materials to the point where it is necessary to step over them.

- Keep all body parts, conductive objects or parts of the machine a safe distance from power lines or live components, unless the local, government and national regulations in force, the employer's safety rules or the rules for work sites are stricter in terms of the distance required.
- Take into account the movement of the platform and the swinging or sagging of the power lines.

U = RATED VOLTAGE (KILOVOLTS)	SAFETY DISTANCE (METRES)
U < 50	3
50 < U < 200	5
200 < U < 350	6
350 < U < 500	8
500 < U < 750	11
750 < U < 1,000	14

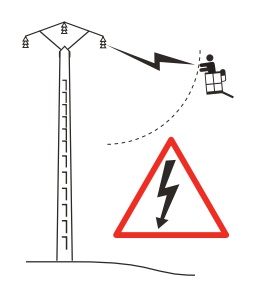

The diagram illustrates a worker on a platform near a power line. A lightning bolt symbol indicates a warning of electrical hazard. A red triangle with a lightning bolt inside is a standard warning sign for high voltage.

- To visually recognise the wind speed, refer to the empirical wind evaluation scale:

BEAUFORT scale (wind speed at a height of 10 m on a flat site)						
Force	Type of wind	Speed (knots)	Speed (km/h)	Speed (m/s)	Effects on Land	Sea conditions
0	Calm	0 - 1	0 - 1	<0.3	Smoke rises vertically.	Sea is like a mirror.
1	Light air	1 - 3	1 - 5	0.3 - 1.5	Smoke indicates direction of wind.	Ripples with appearance of scale, no foam crests.
2	Light breeze	4 - 6	6 - 11	1.6 - 3.3	Wind felt on face, leaves rustle.	Short wavelets, but pronounced.
3	Gentle breeze	7 - 10	12 - 19	3.4 - 5.4	Leaves and small twigs in constant motion.	Very small waves, crests begin to break.
4	Moderate breeze	11 - 16	20 - 28	5.5 - 7.9	Wind raises dust and loose pieces of paper; small branches are moved.	Small waves, becoming longer, numerous whitecaps.
5	Fresh breeze	17 - 21	29 - 38	8 - 10.7	Small trees in leaf begin to sway.	Wavelets form on inland waters; moderate waves, taking longer form.
6	Strong breeze	22 - 27	39 - 49	10.8 - 13.8	Large branches in motion, whistling heard in overhead wires, umbrella use becomes difficult.	Larger waves forming, whitecaps everywhere, some spray.
7	Near gale	28 - 33	50 - 61	13.9 - 17.1	Whole trees in motion, inconvenience felt when walking against the wind.	Sea heaps up; white foam from breaking waves begins to be blown in streaks along the direction of the wind.
8	Gale	34 - 40	62 - 74	17.2 - 20.7	Wind breaks twigs off trees; impedes progress.	Moderately high waves of greater length; edges of crests begin to break into spindrift.
9	Strong gale	41 - 47	75 - 88	20.8 - 24.4	Wind damages roofs (chimneys, slates, etc.).	High waves, crests of waves begin to topple, streaks of foam; reduced visibility.
10	Storm	48 - 55	89 - 102	24.5 - 28.4	Seldom experienced inland; trees uprooted; considerable structural damage occurs.	Very high waves; white streaks of foam; reduced visibility.
11	Violent storm	56 - 63	103 - 117	28.5 - 32.6	Very rare, widespread damage.	Exceptionally high waves able to hide medium sized ships from view, reduced visibility.
12	Hurricane	64 +	118 +	32.7 +	Devastating damage.	Sea completely white; air filled with foam and spray, very reduced visibility.

D - VISIBILITY

- Ensure good visibility of your route at all times. To increase your visibility, you can move forwards with the jib slightly raised (beware of the risk of falls in the platform from knocking into a low doorway, overhead electric wires, travelling cranes, road bridges, railway lines or any obstacle in the area in front of the machine). While reversing, look directly behind you. In any case, avoid reversing long distances.
- If visibility of your road is inadequate, ask someone to help, standing outside the area in which the machine will be moving, and make sure you always have a good view of this person.

E - STARTING MACHINES WITH A DIESEL ENGINE

⚠ IMPORTANT ⚠

Failure to respect polarity between batteries can cause serious damage to the electrical circuit.

The electrolyte in the battery may produce an explosive gas.

Avoid flames and generation of sparks close to the batteries. Never disconnect a battery while it is being charged.

- INSTRUCTIONS: 2 - DESCRIPTION.
- If using an emergency battery for start-up, use a battery with the same characteristics and respect battery polarity when connecting it. Connect the positive terminal first, and then the negative terminal.

F - SWITCHING ON ELECTRICAL MACHINES

- INSTRUCTIONS: 2 - DESCRIPTION
- Do not use the machine if the battery or batteries are discharged to the point that movements are slowed down. In certain cases, the machine may stop (2 - DESCRIPTION for the charge level not to be exceeded).

G - DRIVING THE MACHINE

⚠ IMPORTANT ⚠

Operators should be aware of the risks connected with using this machine, notably:

- Risk of losing control.

- Risk of the machine becoming unstable.

The operator must remain in control of the machine at all times.

- Do not attempt any operations outside the machine's capabilities.
- Familiarise yourself with the machine on the terrain where it will be used.
- Driving long distances should always be done with the machine in the transport position (2 - DESCRIPTION).
- Drive smoothly and adapt the machine's speed to the usage conditions (ground configuration, load in the platform, etc.). Depending on the machine model, select the appropriate speed for the usage conditions (2 - DESCRIPTION).
- Keep control of the speed in all circumstances.
- Ensure that the brakes work efficiently, taking into account the braking distances.
- Take extreme care when manoeuvring the machine with the platform raised. Ensure that there is sufficient visibility.
- Take bends slowly.
- Look where you are going and always make sure you have good visibility along the route.
- Drive round obstacles.
- Never drive on the edge of a ditch or steep slope.
- Travel slowly on damp, slippery or uneven terrain or on loading ramps.
- Machines with a diesel engine: never leave the engine running when the machine is unattended.
- Never leave the machine switched on during the operator's absence.
- Whatever your operating speed, you must reduce the speed as much as possible before stopping.
- The machine should be operated in an area free of any obstructions or danger when the platform is lowered to the ground.
- Pay attention to structures, objects and people when manoeuvring.
- The operator using the machine must be aided on the ground by a person with adequate training.
- Remain within the limits of the machine's movement amplitude (2 - DESCRIPTION).
- Do not load the platform if the machine needs to travel on a steep slope.

H - SHUTTING DOWN THE MACHINE

⚠ IMPORTANT ⚠

Machines with a diesel engine: before stopping the engine after intensive use, leave the engine idling for a few moments to allow the coolant and oil to gradually lower the temperature of the engine and prevent damage.

- INSTRUCTIONS: 2 - DESCRIPTION.
- Park the machine on a flat surface.
- Make sure that the machine is not stopped in any position that will interfere with the traffic flow and in particular the machine should not be less than one metre from a railway track.
- Never leave the ignition key in the machine during the operator's absence.
- Close and lock (if applicable) all the machine's covers.
- In the event of prolonged parking on a site, protect the machine from bad weather, particularly from frost. Machines with a diesel engine: check the antifreeze protection level.

INSTRUCTIONS FOR WELDING AND BLOW TORCH WORK ON AN EXTERNAL STRUCTURE

⚠ IMPORTANT ⚠

Ensure that there are no hydraulic or electrolyte leaks on the machine.

⚠ IMPORTANT ⚠

When welding, work in the opposite direction from the control panel to avoid sparks damaging it.

- Any welding and cutting (blowtorch) work from the platform on a building's metallic structures requires the following precautions to be taken:

A - WITH AN ELECTRICAL WELDING SET

- It is essential that the machine has a discharge braid connecting the chassis of the machine to the ground.
- It is also essential that the external structure to be welded is connected to the earth.
- If the above conditions are observed, the machine can, in this case, be in contact with the structure or the elements to be welded without damaging the electronic components.
- The power supply to the welding equipment must be via a grounded socket, including the extension lead if required.
- In all cases, make sure that there are no electric arcs in the platform or on the machine (contact between the rod or torch and ground plug of the welding equipment). For this, the ground plug of the welding equipment must never be placed on the machine's platform; it must only be placed as close as possible to the part to be welded.
- Switch off the welding equipment before disconnecting the ground clamp from the element or elements to be welded.

B - WITH A BLOW TORCH

- Attach the blow torch's bottles to the platform's vertical posts.
- Sparks and clippings must not be directed towards the battery or batteries.
- Do not set the blow torch down on the floor of the platform while it is still operating or point it towards the control panel or its power supply harness.

MACHINE MAINTENANCE INSTRUCTIONS

GENERAL INSTRUCTIONS

⚠ IMPORTANT ⚠

Carefully read and understand this instruction manual before working on this machine.

Carry out all repairs immediately, even if the repairs concerned are minor.

Repair all leaks immediately, even if the leak concerned is minor.

Be careful of the risk of burning and splashing (exhaust, radiator, engine, hydraulic oil, etc.).

- Wear clothes suitable for the maintenance of the machine, avoid wearing jewellery and loose clothes. Tie and protect your hair, if necessary.
- Ensure that process materials and of spare parts are disposed in all safely and in an ecological manner.
- Machines with a diesel engine:
 - Make sure the area is adequately ventilated before starting the engine.
 - Before working on the machine: turn off the engine and power down the machine (↩ 2 - DESCRIPTION).
- Electrical machines:
 - Before working on the machine: power down the machine (↩ 2 - DESCRIPTION).

MAINTENANCE

- Perform the periodic service (↩ 3 - MAINTENANCE) to keep your machine in good working condition. Failure to perform the periodic service may annul the contractual guarantee.

MAINTENANCE LOGBOOK

- The maintenance operations carried out in accordance with the recommendations given in section 3 - MAINTENANCE and the other inspection, servicing or repair operations or modifications performed on the machine must be recorded in a maintenance logbook.
- The entry for each operation shall include details of the date of the works, the names of the individuals or companies having performed them, the type of operation and its frequency, if applicable.
- The part numbers of any machine items replaced shall also be indicated.

LUBRICANT AND FUEL LEVELS

- Use the recommended lubricants and never use contaminated lubricants.
- Machines with a diesel engine:
 - Do not fill the fuel tank when the engine is running.
 - Only fill up the fuel tank in areas specified for this purpose.
 - Do not smoke or approach the machine with a flame, when the fuel tank is open or is being filled.

HYDRAULICS

⚠ IMPORTANT ⚠

COUNTERBALANCE VALVE: *it is dangerous to change the setting or remove the counterbalance valves or safety valves which may be fitted to your machine's cylinders.*

These operations must only be performed by approved personnel (consult your dealer).

HYDRAULIC ACCUMULATOR (depending on the model): *it is dangerous to disassemble the hydraulic accumulators and their pipes that may be on your machine. These operations must only be performed by approved personnel (consult your dealer).*

- Any work on the hydraulic circuit is forbidden except for the operations described in section 3 - MAINTENANCE.
- Do not attempt to loosen unions, hoses or hydraulic components with the circuit under pressure.

ELECTRICITY

⚠ IMPORTANT ⚠

*Certain maintenance operations may need electrical accreditation: comply with local, government and national regulations in force.
After each job, make sure that electrical component protection is put back in place (caps, covers, terminal covers, etc.).*

- Do not drop metallic items on the battery or batteries (between the positive and negative terminals).
- Disconnect the battery or batteries before working on the electrical circuit.
- The control panels on the ground and in the platform and all other electrical control boxes must only be opened by authorised personnel.

TILT SENSOR

⚠ IMPORTANT ⚠

Some machines are fitted with a tilt sensor attached to the turntable (⚠ 2 - DESCRIPTION: CONTROL PANEL AND SAFETY DEVICES ON THE GROUND), always carry out an initialisation after removing/refitting the tilt sensor. Refer to the machine repair manual.

Some platforms are fitted with a tilt sensor that is integrated into the ground level control panel (⚠ 2 - DESCRIPTION: CONTROL PANEL AND SAFETY DEVICES ON THE GROUND), always calibrate the tilt sensor after removing/refitting or loosening/tightening the ground level control panel, its mounting plates or fixing screws. Refer to the machine repair manual.

WELDING ON THE MACHINE

⚠ IMPORTANT ⚠

Welding operations on the machine for the purposes of maintenance or repairs must only be carried out by persons authorised by MANITOU.

- Disconnect the battery or batteries before doing any welding on the machine.
- When carrying out electric welding work on the machine, connect the negative cable from the welding equipment directly to the part being welded, so as to avoid high tension current passing through the alternator or the ring gear.
- If the machine is equipped with electronic controls, disconnect them before starting to weld, to avoid the risk of causing irreparable damage to electronic components.

WASHING THE MACHINE

⚠ IMPORTANT ⚠

When cleaning with a high pressure cleaner, avoid air from entering the engine, the piston rod wiper seals, the hinges, the structural components and the electrical connections, etc.

- Clean the machine or at least the area concerned before any intervention.
- Close and lock (if applicable) all the machine's covers.
- If necessary, protect components likely to be damaged, and in particular the electrical components (variable speed drive, charger) and electrical connections and the injection pump from penetration by water, steam or cleaning products.
- Clean the machine of any traces of fuel, oil or grease.
- After washing:
 - Dry the electrical components.
 - Grease the axles, pins, ring gear, etc.

IF THE MACHINE IS NOT TO BE USED FOR A LONG TIME

INTRODUCTION

⚠ IMPORTANT ⚠

*Procedures to follow if the machine is not to be used for a long time and for starting it up again afterwards must be performed by your dealership.
This period of long-term stoppage must not exceed 12 months.*

- The recommendations below are intended to prevent the machine from being damaged when it is withdrawn from service for a period longer than 6 months.

PREPARATION OF THE MACHINE

- Clean the machine thoroughly.
- Check and repair any leaks of fuel, oil, etc.
- Replace or repair any worn or damaged parts.
- Touch up the paintwork if necessary.
- Make sure the cylinder rods are in the retracted position (if applicable).
- Shut down the machine.
- Release the pressure in the hydraulic circuits.

MACHINES WITH A DIESEL ENGINE: ENGINE PROTECTION

- Fill the fuel tank (↩ 3 - MAINTENANCE).
- Replace the engine oil and oil filter (↩ 3 - MAINTENANCE).
- Replace the coolant (↩ 3 - MAINTENANCE).
- Disconnect the battery and store it in a safe place away from the cold, after charging it to a maximum.
- Block the outlet with waterproof adhesive tape.
- Remove the belt and store it in a safe place.
- Disconnect the engine cut-off solenoid on the injection pump and carefully insulate the connection.

ELECTRICAL MACHINES: BATTERY CHARGE

- In order to preserve battery life and capacity, check them periodically and keep the charge level constant (↩ 2 - DESCRIPTION).
- Do not leave the battery charger connected during a lightning storm.

PROTECTING THE MACHINE

- Protect cylinder rods that will not be retracted from corrosion.
- Wrap the wheels.

NOTE: if the machine is to be stored outdoors, cover it with a waterproof tarpaulin.

⚠ IMPORTANT ⚠

Make sure the area is adequately ventilated before starting machines with a diesel engine.

- Remove the protection from the cylinder rods and wheels.
- Check the hydraulic oil (↖ 3 - MAINTENANCE).
- Machines with a diesel engine:
 - Refit and reconnect the battery.
 - Remove the waterproof adhesive tape from the exhaust outlet.
 - Clean the fuel tank (replace the fuel), replace the fuel filter(s) (↖ 3 - MAINTENANCE).
 - Refit the belt and adjust its tension (↖ 3 - MAINTENANCE).
 - Reconnect the engine cut-off solenoid.
 - Start the engine, following the safety instructions and regulations.
- Perform the daily maintenance (↖ 3 - MAINTENANCE).
- Lubricate the machine completely (↖ 3 - MAINTENANCE).
- Carry out all the lifting system's hydraulic movements right up to the limit switches for each cylinder.

DISPOSING OF THE MACHINE



Consult your dealer before disposing of the machine.

RECYCLING OF MATERIALS

METALS

- Metals are 100% recoverable and recyclable.

PLASTICS

- Plastic parts are identified with a marking in accordance with current regulations.
- A limited range of materials is used to simplify the recycling process.
- The majority of the plastic components are made of "thermoplastic" plastics, which are easily recycled by melting, granulating or grinding.

RUBBER

- Tyres and seals can be ground for use in cement manufacture or to obtain reusable granules.

GLASS

- Glass items can be removed and collected for processing by glaziers.

ENVIRONMENTAL PROTECTION

By entrusting the maintenance of your machine to the MANITOU network, the risk of pollution is limited and the contribution to environmental protection is made.

WORN OR DAMAGED PARTS

- Do not dump them in the countryside.
- MANITOU and its network have signed-up to a scheme of environmental protection through recycling.

USED OIL

- The MANITOU network organises the collection and processing of used oil.
- By handing over your waste oil to MANITOU, the risk of pollution is limited.

USED BATTERIES

- Do not throw away batteries, as they contain metals that are harmful for the environment.
- Return them to the MANITOU network or any other approved collection point.

NOTE: MANITOU aims to manufacture machines that provide the best performance and limit polluting emissions.

2 - DESCRIPTION

2 - DESCRIPTION

"CE" DECLARATION OF CONFORMITY 260 TJ+	2-4
"CE" DECLARATION OF CONFORMITY 280 TJ	2-6
COMPONENT LOCATIONS	2-8
STICKERS	2-12
CHARACTERISTICS 260 TJ+	2-32
DIMENSIONS AND AMPLITUDE OF MOVEMENT 260 TJ+	2-36
CHARACTERISTICS 280 TJ	2-38
DIMENSIONS AND AMPLITUDE OF MOVEMENT 280 TJ	2-42
SAFETY COMPONENTS	2-44
SLIDING MID RAILS	2-44
SLIDING MID RAILS AND GATE	2-44
SLIDING MID RAIL	2-44
SAFETY HARNESS ATTACHMENT POINTS	2-44
HANDRAILS	2-45
TURNTABLE LOCKING PIN	2-45
CONTROL PANEL AND SAFETY DEVICES AT GROUND LEVEL	2-46
CONTROL PANEL AND SAFETY DEVICES IN THE PLATFORM	2-48
REMOTE CONTROL UNIT	2-50
GROUND LEVEL DISPLAY SCREEN	2-72
POWER-UP CYCLE	2-72
DISPLAY ZONES	2-72
PREHEAT PAGE	2-75
WORK PAGE	2-75
ALERT PAGE AND FAULT PAGE	2-76
OPERATING THE MACHINE	2-78
TRANSPORT/WORKING POSITION	2-78
TRANSPORT POSITION	2-78
WORKING POSITION	2-78
OPERATION FROM THE GROUND LEVEL CONTROL PANEL	2-80
SWITCH ON THE MACHINE	2-80
SWITCH OFF THE MACHINE	2-80
START THE DIESEL ENGINE	2-80
SWITCH OFF THE DIESEL ENGINE	2-80
POSITION THE PLATFORM	2-80
ACTIVATE SIMULTANEOUS FUNCTIONS	2-80
EMERGENCY STOP	2-80
USE FROM THE PLATFORM CONTROL PANEL	2-81
TURN THE MACHINE ON/OFF	2-81
START THE DIESEL ENGINE	2-81
SWITCH OFF THE DIESEL ENGINE	2-81

DRIVE, STEER AND BRAKE THE MACHINE	2-81
POSITION THE PLATFORM.	2-81
ACTIVATE SIMULTANEOUS FUNCTIONS	2-81
EMERGENCY STOP	2-81
OPERATION FROM THE REMOTE CONTROL UNIT	2-82
TURN THE MACHINE ON/OFF.	2-82
START THE DIESEL ENGINE	2-82
SWITCH OFF THE DIESEL ENGINE	2-82
POSITION THE PLATFORM.	2-82
ACTIVATE SIMULTANEOUS FUNCTIONS	2-82
EMERGENCY STOP	2-82
DIESEL ENGINE AUTOMATIC STOP SYSTEM "STOP AND GO".	2-83
AUTOMATIC EXHAUST REGENERATION	2-86
"STATIONARY MACHINE" EXHAUST REGENERATION.	2-88
LOCKED FUNCTIONS	2-90
MACHINE IN TRANSPORT POSITION	2-90
MACHINE IN WORKING POSITION.	2-91

EMERGENCY CONTROLS **2-92**

SHOULD THE USER FEEL ILL - PRIORITY CONTROLS FROM THE GROUND	2-92
IF THERE IS A BREAKDOWN - EMERGENCY CONTROLS FROM THE PLATFORM	2-92
IF THERE IS A BREAKDOWN - EMERGENCY CONTROLS FROM THE GROUND.	2-93

STANDARD EQUIPMENT **2-96**

OSCILLATING FRONT AXLE	2-96
----------------------------------	------

OPTIONS **2-97**

KEY LOCK FOR TURNTABLE COVERS	2-97
BATTERY CUT-OFF	2-97
230 V ELECTRIC POWER SOCKET IN THE PLATFORM	2-97
BATTERY HEATER	2-98
HYDRAULIC OIL HEATER	2-98
ENGINE BLOCK HEATER	2-99
ELECTRIC GENERATOR.	2-100
PLATFORM WORKLIGHT.	2-101
SECONDARY PROTECTION SYSTEM SPS.	2-102

TRANSPORT AND LIFTING **2-104**

TRANSPORT INSTRUCTIONS	2-104
LOADING/UNLOADING THE MACHINE	2-104
CONFIGURE THE MACHINE FOR TRANSPORT 260 TJ+	2-105
CONFIGURE THE MACHINE FOR TRANSPORT 280 TJ	2-106
SECURING THE MACHINE 260 TJ+	2-108
SECURING THE MACHINE 280 TJ	2-109
FREEWHEEL FOR WINCHING	2-110
LIFTING INSTRUCTIONS 260 TJ+	2-112
LIFTING INSTRUCTIONS 280 TJ	2-114

DÉCLARATION «CE» DE CONFORMITÉ (originale)

"CE" DECLARATION OF CONFORMITY (original) (1)

- (2) Constructeur, **manufacturer:** Manitou BF
(3) Adresse, **Address:** 430, RUE DE L'AUBINIÈRE - B.P 10249
44158 - ANCENIS - CEDEX - FRANCE
(4) Titulaire du dossier technique, **Holder of the technical file:** Manitou BF
(3) Adresse, **Address:** 430, RUE DE L'AUBINIÈRE - B.P 10249
44158 - ANCENIS - CEDEX - FRANCE
(5) Le constructeur déclare que la machine décrite ci-après, **The manufacturer declares that the machine described below: 260 TJP ST5 S1**

- (6) - Est conforme aux directives suivantes et à leurs transpositions en droit national (si applicables),
Complies with the following directives and their transpositions into national law (if applicable):

2006/42/EC

- (7) - Pour les machines annexe IV, **For annex IV machines:**

(8) - Numéro d'attestation, **Certificate number:** 2681 5131 xxx xx xx xxxx

(9) - Organisme notifié, **Notified body:** BUREAU VERITAS INT. - 61-71 BD DU CHATEAU
92200 NEUILLY-SUR-SEINE

2000/14/EC + 2005/88/EC

- (10) - Procédure appliquée, **Applied procedure:** ANNEX V

(9) - Organisme notifié, **Notified body:** SNCH - 11 ROUTE DU LUXEMBOURG
5201 SANDWEILER

- (11) - Niveau de puissance acoustique, **Sound power level:**

(12) Mesuré, **Measured:** dB (A)

(13) Garanti, **Guaranteed:** dB (A)

2014/30/EU

- (14) - Normes harmonisées utilisées, **Harmonised standards used:**
EN12895
 (15) - Normes ou dispositions techniques utilisées, **Standards or technical provisions used:**

(16) - Fait à, **Done at:**

(17) - Date, **Date :**

(18) - Nom du signataire, **Name of signatory:**

(19) - Fonction, **Function:**

(20) - Société, **Company:**

(21) - Signature, **Signature:**

bg : (1) „ЕО” декларация за съответствие (оригинал), (2) Производител, (3) Адрес, (4) Притежател на техническото досие, (5) Производителът декларира, че описаната по-долу машина, (6) Е в съответствие със следните директиви и технико трансponирано в националното законодателство (ако е приложимо), (7) Приложение IV относно машините, (8) Номер на сертификата, (9) Нотифициран орган, (10) Приложена процедура, (11) Ниво на силата на звука, (12) Измерено, (13) Гарантирано, (14) Използвани хармонизирани стандарти, (15) Използвани стандарти или технически разпоредби, (16) Изработено в, (17) Дата, (18) Име на подписващото лице, (19) Дължност, (20) Фирма, (21) Подпис

cs : (1) ES prohlášení o shodě (původní), (2) Výrobce, (3) Adresa, (4) Držitel technické dokumentace, (5) Výrobce prohlašuje, že zařízení popsané níže, (6) Je v souladu s následujícími směrnici a směrnici transponovanými do vnitrostátního práva (je-li relevantní), (7) Pro stroje v příloze IV(8) Číslo certifikátu, (9) Notifikační orgán, (10) Použitý postup, (11) Úroveň hluku (12) Naměřená, (13) Zaručená, (14) Použité harmonizované normy, (15) Použité normy nebo technické předpisy(16) Místo (17) Datum (18) Jméno podepsaného, (19) Funkce, (20) Společnost, (21) Podpis

da : (1) EF Overensstemmelseserklæring (original), (2) Producent, (3) Adresse, (4) Indehaver af det tekniske dossier, (5) Producenten erklærer, at maskinen, der er beskrevet nedenfor, (6) overholder nedenstående direktiver og disse gennemførelse til national ret (hvis det er relevant), (7) For maskiner under bilag IV, (8) Certifikat nummer, (9) Bemyndigede organ, (10) Anvendt procedure, (11) Lydeffektniveau, (12) Målt, (13) Garanti, (14) Anvendte harmoniserede standarder, (15) Standarder eller tekniske regler, (16) Udfærdiget i, (17) Dato, (18) Underskrivers navn, (19) Funktion, (20) Firma, (21) Underskrift.

de : (1) EG-Konformitätsbescheinigung (original), (2) Hersteller, (3) Adresse, (4) Inhaber des technischen Dokuments, (5) Der Hersteller erklärt, dass die nachstehend beschriebene Maschine (6) den folgenden Richtlinien und deren Umsetzung in die nationale Gesetzgebung entspricht (falls anwendbar), (7) Für die Maschinen laut Anhang IV, (8) Bescheinigungsnummer, (9) Benannte Stelle, (10) Angewandtes Verfahren, (11) Schalleistungspegel, (12) Gemessen, (13) Gewährleistet, (14) angewandte harmonisierte Normen, (15) angewandte sonstige technische Normen und Bestimmungen, (16) Ausgestellt in, (17) Datum, (18) Name des Unterzeichners, (19) Funktion, (20) Gesellschaft, (21) Unterschrift.

el : (1) Δήλωση συμμόρφωσης CE (πρωτότυπο), (2) Κατασκευαστής, (3) Διεύθυνση, (4) Κάτοχος του τεχνικού φακέλου, (5) Ο κατασκευαστής δηλώνει ότι το μηχάνημα που περιγράφεται παρακάτω, (6) Συμμορφώνεται με τις επί της ουσίας και τις προσαρμογές τους στο εθνικό δίκαιο (κατά περίπτωση), (7) Για το μηχάνημα του παραρτήματος IV, (8) Αριθμός πιστοποιητικού, (9) Διοικητικό όργανο, (10) Εφαρμοζόμενη διαδικασία, (11) Επίπεδο ηχητικής ισχύος, (12) Καταγεγραμμένο, (13) Εγγυημένο, (14) Εναρμονισμένα πρότυπα που χρησιμοποιούνται, (15) Πρότυπα ή τεχνικοί κανόνες που χρησιμοποιούνται, (16) Τόπος, (17) Ημερομηνία, (18) Όνομα του υπογράφοντος, (19) Ιδιότητα, (20) Εταιρεία, (21) Υπογραφή

es : (1) Declaración CE de conformidad (original), (2) Fabricante, (3) Dirección, (4) Titular del expediente técnico, (5) El fabricante declara que la máquina que se describe a continuación, (6) Cumple con las siguientes directivas y sus transposiciones a la legislación nacional (en caso oportuno), (7) Para las máquinas anexo IV, (8) Número de certificación, (9) Organismo notificado, (10) Procedimiento aplicado, (11) Nivel de potencia acústica, (12) Medido, (13) Garantizado, (14) Normas armonizadas utilizadas, (15) Otras normas o especificaciones técnicas utilizadas, (16) Hecho en, (17) Fecha, (18) Nombre del signatario, (19) Cargo, (20) Empresa, (21) Firma.

et : (1) EÜ vastavusdeklaratsioon (algupärane), (2) Tootja, (3) Aadress, (4) Tehnilise dokumentatsiooni valdaja, (5) Tootja kirjutab, et allpool kirjeldatud seade, (6) On vastavuses järgmistele direktiivide ja nende riigisisesele õigussisse ülevõtmiseks vastuvõetud õigusaktidega (kui on kohaldatav), (7) IV lisas loetletud seadmele puhul, (8) Tunnistusnumber, (9) Sertifitseerimisüksus, (10) Kohaldatav menetlus, (11) Akustilise võimsuse tase, (12) Mõeldud, (13) Tagatud, (14) Vastab kehtivatele ühustatud standarditele, (15) Vastab muudele kehtivatele standarditele ja tehnilistele normidele, (16) Väijaandmise koht, (17) Väijaandmise aeg, (18) Allkirjastaja nimi, (19) Amet, (20) Ettevõtte, (21) Allkiri

fi : (1) EY-vastavuslupausvaakaus (alkuperäinen), (2) Valmistaja, (3) Osasto, (4) Teknisten asiakirjojen haltaja, (5) Valmistaja ilmoittaa, että alla kuvattu laite, (6) Täyttää seuraavien direktiivien sekä niitä vastaavien kansallisten säätöjen vaatimukset (tarvittaessa), (7) Liitteen IV listoiden osalta, (8) Todistusnumero, (9) Ilmoitettu laitos, (10) Käytetty menettelytapa, (11) Äänen tehotaso, (12) Mittattu, (13) Taattu, (14) Käytetyt yhdenmukaistetut standardit, (15) Käytetyt tekniset standardit tai säännökset, (16) Paikka, (17) Aika, (18) Allekirjoittajan nimi, (19) Toini, (20) Yritys, (21) Allekirjoitus.

ga : (1) Dearbhú comhréireachta « CE » (bunaidh), (2) Déantóir, (3) Seoladh, (4) Sealbóir an chomhad ticeiníúil, (5) Dearbhóir an déantóir go ndéantar go ndéantar an t-inneal ar a bhfuil cur síos dhios, (6) Cloíonn sé le na teoiricí seo a leanas agus lena dtuasailtí i ndlí náisiúnta (más cúl), (7) Le haghaidh innill an aguslín IV, (8) Ulmhír teastais, (9) Comhlacht a dtagtar fógra dó, (10) Níos ísle ná a cnuasán ná bhéicéim, (11) Leibhéal cumhachta na huaine, (12) Tomhasa, (13) Ráthaíthe, (14) Caighdeán chomhréireachta a úsáidtear, (15) Caighdeán nó forlíacha teicniúla a úsáidtear, (16) Arís dhéanann ag, (17) Dáta, (18) Ainm an tsinneara, (19) Feidhmeannas, (20) Comhlacht (21) Síniú.

hr : (1) EK deklaracija o usklađenosti (original), (2) Proizvođač, (3) Adresa, (4) Nositelj tehničke dokumentacije, (5) Proizvođač izjavlja da stroj opisan u nastavku, (6) Ispunjava slijedeće direktive i njihovom prijenosu u nacionalno zakonodavstvo (ako je primjenjivo), (7) Za dodatke IV o strojevima, (8) Broj certifikata, (9) Ovlašteno tijelo, (10) Primjenjeni postupak, (11) Razina snage zvuka, (12) Izmjereno, (13) Zajamčeno, (14) Primjenjeni standardi o harmoniziranju, (15) Primjenjeni standardi ili tehničke priloge, (16) Uradeno u, (17) Datum, (18) Ime potpisnika, (19) Funkcija, (20) Tvrtka, (21) Potpis.

hu : (1) CE megfelelőségi nyilatkozat (eredeti), (2) Gyártó, (3) Cím, (4) A műszaki dokumentáció birtokosa, (5) A gyártó kijelenti, hogy az alábbi termék, (6) Megfelel az alábbi irányelveknek valamint azok honosított előírásainak (ha vannak ilyenek), (7) A IV. melléklet gépeinek (adott esetben), (8) Bizonyítási szám, (9) Ertesített szervezet, (10) Akkumulált előírás, (11) Akusztikus hang szint, (12) Mért, (13) Garantiált, (14) Felhasznált harmonizált szabványok, (15) egyéb felhasznált műszaki szabványok és előírások hivatkozásai, (16) Kelt (hely), (17) Dátum, (18) Aláíró neve, (19) Funkció, (20) Vállalat, (21) Aláírás

is : (1) Sammenhangsögnings erklæring (upprunaleg), (2) Framleiðandi, (3) Aðsetur, (4) Handhafni tekniskrár, (5) Framleiðandi staðfestir að vélin sem lýst er hér, (6) Samræmist eftirfarandi stöðlum og staðfarstu þeirra sem hlýðandi af þjóðarriti (ef við á), (7) Fyrir tækjabúnað í IV. viðauka, (8) Númer vottorðs, (9) Tilkynnt til, (10) Aðferð beiðu, (11) Hljóðstyrkur, (12) Mældist, (13) Ábyrgð, (14) Samhljófar staðlar sem notaðir voru, (15) Aðrir staðlar eða teknilegar forskritir, (16) Staður, (17) Dagsetning, (18) Nafn undirritaðs, (19) Staða, (20) Fyrirritari, (21) Underskrift.

it : (1) Dichiarazione CE di conformità (originale), (2) Costruttore, (3) Indirizzo, (4) Titolare del fascicolo tecnico, (5) Il costruttore dichiara che la macchina descritta di seguito, (6) È conforme alle direttive seguenti e al relativo recepimento nella normativa nazionale (se applicabile), (7) Per le macchine Allegato IV, (8) Numero di Attestazione, (9) Organismo destinatario della notifica, (10) Procedura applicata, (11) Livello di potenza acustica, (12) Misurato, (13) Garantito, (14) Norme armonizzate applicate, (15) Norme e specifiche tecniche applicate, (16) Luogo, (17) Data, (18) Nome del firmatario, (19) Funzione, (20) Società, (21) Firma.

lt : (1) EC atitikties deklaracija (originalas), (2) Gamintojas, (3) Adresas, (4) Techninės bylos turėtojas, (5) Gamintojas nurodo, kad mašina, aprašyta žemiau, (6) atitinka toliau nurodytas direktyvas ir nacionalinius teisės aktus perkeltus į nuostatas (jei taikytina), (7) IV priedas dėl mašinų, (8) Serifikato Nr., (9) Notifikuojoji įstaiga, (10) Taikytą procedūrą, (11) Garso stiprumo lygis, (12) Išmatuotas, (13) Garantuojamas, (14) Naudojami dariniai standartai, (15) Kit naudojami standartai ir techninės specifikacijos, (16) Pasirašyta, (17) Data, (18) Pasirašiusio asmens vardas ir pavardė, (19) Pareigos, (20) Bendrovė, (21) Parašas

lv : (1) EK atbilstības deklarācija (originals), (2) Ražotājs, (3) Adrese, (4) Tehniskās dokumentācijas turētājs, (5) Ražotāja apliecinā, ka turpmāk aprakstītā mašina, (6) Atbilst tālāk norādītajām direktīvam un to iekļaušanai nacionālajā iekumdošanā (ja piemērojama), (7) IV pielikuma iekārtām, (8) Serifikācija numurs, (9) Pilsvarotā iestāde, (10) Piemērotā procedūra, (11) Skarņas jaudas līmenis, (12) Izmērīts, (13) Garantēts, (14) Piemērojamie saistītie standarti, (15) Piemērojamie tehniskie standarti un noteikumi, (16) Sastādīts, (17) Datums, (18) Parakstītāja vārds, (19) Amats, (20) Uzņēmums, (21) Paraksts

mt : (1) Deklarazzjoni ta' Konformità tal-KE (originali), (2) Manifattur, (3) Indirizz, (4) Detentur tal-fajl tekniku, (5) Il-manifattur jiddeklarja li l-magna descritta hawn taht, (6) Hija konformi hija konforma mad-Direttivi segwenti u l-ħaġġiet li jimpjebawhom fil-ħaġġi nazzjonali (jekk applikabbli), (7) Għasli-magni fl-Anness IV, (8) Numru ta' certifikat, (9) Enitā notifikata, (10) Proċedura applikata, (11) Livell ta' qawwa akustika, (12) Imkejjel, (13) Garantit, (14) l-standards armonizzati użati, (15) standards tekniki u speċifikazzjonijiet oħra użati, (16) Magħmul f, (17) Data, (18) Isem il-firmatarju, (19) Kariġa, (20) Kumpanija (21) Firma.

nl : (1) EG-verklaring van overeenstemming (oorspronkelijk), (2) Fabrikant, (3) Adres, (4) Houder van het technisch dossier, (5) De fabrikant verklaart dat de hieronder beschreven machine, (6) in overeenstemming is met de volgende richtlijnen en hun omzettingen in het nationale recht (indien van toepassing), (7) Voor de machines in bijlage IV, (8) Certificatummer, (9) Aangemelde instantie, (10) Toegepaste procedure, (11) Geluidsvermogensniveau, (12) Gemeten, (13) Gegarandeerd, (14) gehanteerde geharmoniseerde normen, (15) andere gehanteerde technische normen en specificaties, (16) Opgeemaakt te, (17) Datum, (18) Naam van ondergetekende, (19) Functie, (20) Onderneming, (21) Handtekening.

no : (1) CE-samsvarserklæring (original), (2) Producent, (3) Adresse, (4) Innehaver av den tekniske dokumentasjonen, (5) Producenten sier at maskinen beskrevet nedenfor, (6) Oppfyller kravene i følgende direktiver og med nasjonale gjennomføringsbestemmelser (hvis aktuelle), (7) For maskinene i bilag IV, (8) Attestnummer, (9) Teknisk kontrollorgan, (10) Anvendt prosedyre, (11) Akustisk støy, (12) Målt, (13) Garantert, (14) harmoniserte standarder som brukes, (15) Andre standarder og spesifikasjoner som brukes, (16) Utstedt, (17) Dato, (18) Underlegnedes navn, (19) Stilling, (20) Firma (21) Underskrift.

pl : (1) Deklaracja zgodności CE (oryginał), (2) Producent, (3) Adres, (4) Posiadacz dokumentacji technicznej, (5) Producent oświadcza, że opisana poniżej maszyna, (6) Jest zgodna z następującymi dyrektywami i odpowiadającymi im przepisami prawa krajowego (jeśli dotyczy), (7) Dla maszyn załącznik IV, (8) Numer certyfikatu, (9) Jednostka certyfikująca, (10) Procedura stosowana, (11) Poziom mocy akustycznej, (12) Zmierzony, (13) Gwarantowany, (14) zastosowane normy zharmonizowane, (15) Zastosowane normy lub przepisy techniczne, (16) Sporządzono w, (17) Data, (18) Nazwisko podpisującego, (19) Stanowisko, (20) Firma (21) Podpis

pt : (1) Declaração de conformidade CE (original), (2) Fabricante, (3) Morada, (4) Titular do processo técnico, (5) O fabricante afirma que a máquina descrita abaixo, (6) Está em conformidade com as seguintes diretivas e as suas transposições para o direito nacional (se for o caso), (7) Para as máquinas no anexo IV, (8) Número de certificado, (9) Entidade notificada, (10) Procedimento aplicado, (11) Nível de potência acústica, (12) Medida, (13) Garantida, (14) Normas harmonizadas utilizadas, (15) outras normas e especificações técnicas utilizadas, (16) Elaborado em, (17) Data, (18) Nome do signatário, (19) Cargo, (20) Empresa, (21) Assinatura

ro : (1) Declarație de conformitate CE (original), (2) Producător, (3) Adresă, (4) Titularul din dosarul tehnic, (5) Producătorul afirmă că aparatul descris mai jos, (6) Este conform cu directivele următoare și cu transpunerea lor în dreptul național (dacă este cazul), (7) Pentru mașinile din anexa IV, (8) Număr de atestare, (9) Organism notificat, (10) Procedură aplicată, (11) Nivel de putere acustică, (12) Măsurat, (13) Garantat, (14) standardele armonizate utilizate, (15) alte standarde și specificații tehnice utilizate, (16) Intocmit în, (17) Data, (18) Numele persoanei care semnează, (19) Funcția, (20) Firma, (21) Semnătură

sk : (1) Vyhlásenie o zhode ES (pôvodní), (2) Výrobca, (3) Adresa, (4) Držitel technické dokumentácie, (5) Výrobca vyhlasuje, že nižšie popísaný stroj, (6) Je v súlade s nasledujúcimi smernicami a smernicami transponovanými do vnútroštátneho práva (v prípade potreby), (7) Pre stroje v prílohe IV, (8) Číslo certifikátu, (9) Notifikovaný orgán, (10) Použitý postup, (11) Akustická úroveň hluku, (12) Naměřená, (13) Zaručená, (14) Použité harmonizované normy, (15) Iné použité normy a technické predpisy, (16) Miesto vydania, (17) Dátum vydania, (18) Meno podpísanej osoby, (19) Funkcia, (20) Spoločnosť, (21) Podpis

sl : (1) ES izjava o skladnosti (izvirni), (2) Proizvajalec, (3) Naslov, (4) Imetnik tehnične dokumentacije, (5) Proizvajalec izjavlja, da naprava, opisana v nadaljevanju, (6) Ustreza naslednjim smernicam in nacionalni zakonodaji (če ta velja), (7) Za stroje v skladu s prilogo IV, (8) Številka potrdila, (9) Priglasjen organ, (10) Uporabljen postopek, (11) Ravnan akustične moči, (12) Izmerjena, (13) Zajamčena, (14) Uporabljeni usklajeni standardi, (15) Drugi uporabljeni tehnični standardi in specifikacije, (16) V, (17) Datum, (18) Ime podpisnika, (19) Funkcija, (20) Podjetje, (21) Podpis.

sv : (1) EÜ-förklaring om överensstämmelse (original), (2) Tillverkare, (3) Adress, (4) Ägaren av det tekniska underlaget, (5) Tillverkaren försäkras att den maskin som beskrivs nedan, (6) Överensstämmer med nedanstående direktiv och införlivandet av dem i nationell rätt (om tillämpligt), (7) För maskinerna i bilaga IV, (8) Nummer för godkännande, (9) Anmänt organ, (10) Förfarande som tillämpats, (11) Ljudtrycksnivå, (12) Uppmätt, (13) Garanterad, (14) Harmoniserade standarder som använts, (15) andra tekniska standarder och specifikationer som använts, (16) Upprättad i, (17) Datum, (18) Namn på den som undertecknat, (19) Befattning, (20) Företag (21) Namnteckning

DÉCLARATION «CE» DE CONFORMITÉ (originale)

"CE" DECLARATION OF CONFORMITY (original) (1)

- (2) Constructeur, **manufacturer**: Manitou BF
(3) Adresse, **Address**: 430, RUE DE L'AUBINIÈRE - B.P 10249
44158 - ANCENIS - CEDEX - FRANCE
(4) Titulaire du dossier technique, **Holder of the technical file**: Manitou BF
(3) Adresse, **Address**: 430, RUE DE L'AUBINIÈRE - B.P 10249
44158 - ANCENIS - CEDEX - FRANCE
(5) Le constructeur déclare que la machine décrite ci-après, **The manufacturer declares that the machine described below**: **280 TJ ST5 S1**

- (6) - Est conforme aux directives suivantes et à leurs transpositions en droit national (si applicables),
Complies with the following directives and their transpositions into national law (if applicable):

2006/42/EC

- (7) - Pour les machines annexe IV, **For annex IV machines**:

(8) - Numéro d'attestation, **Certificate number**: 2681 5131 xxx xx xx xxxx

(9) - Organisme notifié, **Notified body**: BUREAU VERITAS INT. - 61-71 BD DU CHATEAU
92200 NEUILLY-SUR-SEINE

2000/14/EC + 2005/88/EC

- (10) - Procédure appliquée, **Applied procedure**: ANNEX V

(9) - Organisme notifié, **Notified body**: SNCH - 11 ROUTE DU LUXEMBOURG
5201 SANDWEILER

- (11) - Niveau de puissance acoustique, **Sound power level**:

(12) Mesuré, **Measured**: dB (A)

(13) Garanti, **Guaranteed**: dB (A)

2014/30/EU

- (14) - Normes harmonisées utilisées, **Harmonised standards used**:
EN12895
 (15) - Normes ou dispositions techniques utilisées, **Standards or technical provisions used**:

(16) - Fait à, **Done at**:

(17) - Date, **Date** :

(18) - Nom du signataire, **Name of signatory**:

(19) - Fonction, **Function**:

(20) - Société, **Company**:

(21) - Signature, **Signature**:

bg : (1) „ЕО“ декларация за съответствие (оригинал), (2) Производител, (3) Адрес, (4) Притежател на техническото досие, (5) Производителът декларира, че описаната по-долу машина, (6) Е в съответствие със следните директиви и точното транспониране в националното законодателство (ако е приложимо), (7) Приложение IV относно машините, (8) Номер на сертификата, (9) Нотифициран орган, (10) Приложена процедура, (11) Ниво на силата на звука, (12) Измерено, (13) Гарантирано, (14) Използвани хармонизирани стандарти, (15) Използвани стандарти или технически разпоредби, (16) Изработено в, (17) Дата, (18) Име на подписващото лице, (19) Дължост, (20) Фирма, (21) Подпис

cs : (1) ES prohlášení o shodě (původní), (2) Výrobce, (3) Adresa, (4) Držitel technické dokumentace, (5) Výrobce prohlašuje, že zařízení popsané níže, (6) Je v souladu s následujícími směrnicemi a směrnici transponovanými do vnitrostátního práva (je-li relevantní), (7) Pro stroje v příloze IV(8) Číslo certifikátu, (9) Notifikační orgán, (10) Použitý postup, (11) Úroveň hluku (12) Naměřená, (13) Zaručená, (14) Použité harmonizované normy, (15) Použité normy nebo technické předpisy(16) Místo (17) Datum (18) Jméno podepsaného, (19) Funkce, (20) Společnost, (21) Podpis

da : (1) EF Overensstemmelseserklæring (original), (2) Producent, (3) Adresse, (4) Indehaver af det tekniske dossier, (5) Producenten erklærer, at maskinen, der er beskrevet nedenfor, (6) overholder nedenstående direktiver og disse gennemførelse til national ret (hvis det er relevant), (7) For maskiner under bilag IV, (8) Certifikat nummer, (9) Bemyndigede organ, (10) Anvendt procedure, (11) Lydeffektivniveau, (12) Målt, (13) Garanti, (14) Anvendte harmoniserede standarder, (15) Standarder eller tekniske regler, (16) Udfærdiget i, (17) Dato, (18) Underskrivers navn, (19) Funktion, (20) Firma, (21) Underskrift.

de : (1) EG-Konformitätsbescheinigung (original), (2) Hersteller, (3) Adresse, (4) Inhaber des technischen Dokuments, (5) Der Hersteller erklärt, dass die nachstehend beschriebene Maschine (6) den folgenden Richtlinien und deren Umsetzung in die nationale Gesetzgebung entspricht (falls anwendbar), (7) Für die Maschinen laut Anhang IV, (8) Bescheinigungsnummer, (9) Benannte Stelle, (10) Angewandtes Verfahren, (11) Schalleistungspegel, (12) Gemessen, (13) Gewährleistet, (14) angewandte harmonisierte Normen, (15) angewandte sonstige technische Normen und Bestimmungen, (16) Ausgestellt in, (17) Datum, (18) Name des Unterzeichners, (19) Funktion, (20) Gesellschaft, (21) Unterschrift.

el : (1) Δήλωση συμμόρφωσης CE (πρωτότυπο), (2) Κατασκευαστής, (3) Διεύθυνση, (4) Κάτοχος του τεχνικού φακέλου, (5) Ο κατασκευαστής δηλώνει ότι το μηχάνημα που περιγράφεται παρακάτω, (6) Συμμορφώνεται με τις επίμαχες οδηγίες και τις προσαρμογές τους στο εθνικό δίκαιο (κατά περίπτωση), (7) Για τα μηχανήματα του παραρτήματος IV, (8) Αριθμός πιστοποιητικού, (9) Διοικητικό όργανο, (10) Εφαρμοζόμενη διαδικασία, (11) Επίπεδο ηχητικής ισχύος, (12) Καταγεγραμμένο, (13) Εγγυημένο, (14) Εναρμονισμένα πρότυπα που χρησιμοποιούνται, (15) Πρότυπα ή τεχνικοί κανόνες που χρησιμοποιούνται, (16) Τόπος, (17) Ημερομηνία, (18) Όνομα του υπογράφοντος, (19) Ιδιότητα, (20) Εταιρεία, (21) Υπογραφή

es : (1) Declaración CE de conformidad (original), (2) Fabricante, (3) Dirección, (4) Titular del expediente técnico, (5) El fabricante declara que la máquina que se describe a continuación, (6) Cumpie con las siguientes directivas y sus transposiciones a la legislación nacional (en caso oportuno), (7) Para las máquinas anexo IV, (8) Número de certificación, (9) Organismo notificado, (10) Procedimiento aplicado, (11) Nivel de potencia acústica, (12) Medido, (13) Garantizado, (14) Normas armonizadas utilizadas, (15) Otras normas o especificaciones técnicas utilizadas, (16) Hecho en, (17) Fecha, (18) Nombre del signatario, (19) Cargo, (20) Empresa, (21) Firma.

et : (1) EÜ vastavusdeklaratsioon (algupärane), (2) Tootja, (3) Aadress, (4) Tehnilise dokumentatsiooni valdaja, (5) Tootja kirjutab, et allpool kirjeldatud seade, (6) On vastavuses järgmistele direktiivide ja nende riigisisese õigussisse ülevõtmiseks vastuvõetud õigusaktidega (kui on kohaldatav), (7) IV lisas loetletud seadmele puhul, (8) Tunnistuse number, (9) Sertifitseerimisasutus, (10) Kohaldatav meetod, (11) Akustilise võimsuse tase, (12) Mõeldud, (13) Tagatud, (14) Vastab kehtivatele ühustatud standarditele, (15) Vastab muudele kehtivatele standarditele ja tehnilistele normidele, (16) Väljaandmise koht, (17) Väljaandmise aeg, (18) Allkirjastaja nimi, (19) Amet, (20) Ettevõtte, (21) Allkiri

fi : (1) EY-vastavuslupausvaakaus (alkuperäinen), (2) Valmistaja, (3) Osasto, (4) Teknisten asiakirjojen haltija, (5) Valmistaja ilmoittaa, että alla kuvattu laite, (6) Täyttää seuraavien direktiivien sekä niitä vastaavien kansallisten säätöjen vaatimukset (tarvittaessa), (7) Liitteen IV laittujen osalta, (8) Todistusnumero, (9) Ilmoitettu laitos, (10) Käytetty menetelmätyyppi, (11) Äänen tehollisuus, (12) Mittattu, (13) Taattu, (14) Käytetyt yhdenmukaistetut standardit, (15) Käytetyt tekniset standardit tai säännökset, (16) Paikka, (17) Aika, (18) Allekirjoittajan nimi, (19) Toini, (20) Yritys, (21) Allekirjoitus.

ga : (1) Dearbhú comhréireachta « CE » (bunaidh), (2) Déantóir, (3) Seoladh, (4) Sealbhoir an chomhad ticeinúil, (5) Dearbhóir an déantóir go ndéantar go ndéantar an t-inneal ar a bhfuil cur síos dhíoch, (6) Cloíonn sé le na teoiricí seo a leanas agus lena dtuasailteach i ndlí náisiúnta (más cúl), (7) Le haghaidh innill an agusán IV, (8) Ulmhír teastais, (9) Comhlacht a dtagtar fógra dó, (10) Níos ísle ná a cnuasán ná dhéilecht, (11) Leibhéal cumhachta na huaine, (12) Tomhasa, (13) Ráthaithe, (14) Caighdeán chomhréireachta a úsáidtear, (15) Caighdeán nó fórlacha teicniúla a úsáidtear, (16) Arís dhéanann ag, (17) Dáta, (18) Ainm an tsinneara, (19) Feidhmeannas, (20) Comhlacht (21) Sinlé.

hr : (1) EK deklaracija o usklađenosti (original), (2) Proizvođač, (3) Adresa, (4) Nositelj tehničke dokumentacije, (5) Proizvođač izjavlja da stroj opisan u nastavku, (6) Ispunjava slijedeće direktive i njihovom prijenosu u nacionalno zakonodavstvo (ako je primjenjivo), (7) Za dodatke IV o strojevima, (8) Broj certifikata, (9) Ovlašteno tijelo, (10) Primjenjeni postupak, (11) Razina snage zvuka, (12) Izmjereno, (13) Zajamčeno, (14) Primjenjeni standardi o harmoniziranju, (15) Primjenjeni standardi ili tehničke priloge, (16) Urađeno u, (17) Datum, (18) Ime potpisnika, (19) Funkcija, (20) Tvrtka, (21) Potpis.

hu : (1) CE megfelelőségi nyilatkozat (eredeti), (2) Gyártó, (3) Cím, (4) A műszaki dokumentáció birtokosa, (5) A gyártó kijelenti, hogy az alábbi termék, (6) Megfelel az alábbi irányelveknek valamint azok honosított előírásainak (ha vannak ilyenek), (7) A IV. melléklet gépeinek (adott esetben), (8) Bizonyítási szám, (9) Ertesített szervezet, (10) Akkumulált előírás, (11) Akusztikus hang szint, (12) Mért, (13) Garantiált, (14) Felhasznált harmonizált szabványok, (15) egyéb felhasznált műszaki szabványok és előírások hivatkozásai, (16) Kelt (hely), (17) Dátum, (18) Aláíró neve, (19) Funkció, (20) Vállalat, (21) Aláírás

is : (1) Sammenhangsvotning ESB (upprunaleg), (2) Framleiðandi, (3) Aðsetur, (4) Handhafni tekniskrár, (5) Framleiðandi staðfestir að vélin sem lýst er hér, (6) Samræmist eftirfarandi stöðlum og staðfarstu þeirra með hliðsjón af þjóðarriti (ef við á), (7) Fyrir tækjarnám IV, viðauka, (8) Númer vottrós, (9) Tilkynnt í, (10) Aðferð beiðu, (11) Hljóðstyrkur, (12) Mældist, (13) Ábyrgð, (14) Samhæfdir staðlar sem notaðir eru, (15) Aðrir staðlar eða teknilegar forskritir, (16) Staður, (17) Dagsetning, (18) Nafn undirritaðs, (19) Staða, (20) Fyrirritari, (21) Underskrift.

it : (1) Dichiarazione CE di conformità (originale), (2) Costruttore, (3) Indirizzo, (4) Titolare del fascicolo tecnico, (5) Il costruttore dichiara che la macchina descritta di seguito, (6) È conforme alle direttive seguenti e al relativo recepimento nella normativa nazionale (se applicabile), (7) Per le macchine Allegato IV, (8) Numero di Attestazione, (9) Organismo destinatario della notifica, (10) Procedura applicata, (11) Livello di potenza acustica, (12) Misurato, (13) Garantito, (14) Norme armonizzate applicate, (15) Norme e specifiche tecniche applicate, (16) Luogo, (17) Data, (18) Nome del firmatario, (19) Funzione, (20) Società, (21) Firma.

lt : (1) EC atitikties deklaracija (originalas), (2) Gamintojas, (3) Adresas, (4) Techninės bylos turėtojas, (5) Gamintojas nurodo, kad mašina, aprašyta žemiau, (6) atitinka toliau nurodytas direktyvas ir nacionalinius teisės aktus perkeltus į nuostatas (jei taikytina), (7) IV priedas dėl mašinų, (8) Serifikato Nr., (9) Notifikuojoji įstaiga, (10) Taikytą procedūrą, (11) Garso stiprumo lygis, (12) Išmatuotas, (13) Garantuojamas, (14) Naudojami dariniai standartai, (15) Kit naudojami standartai ir techninės specifikacijos, (16) Pasirašyta, (17) Data, (18) Pasirašiusio asmens vardas ir pavardė, (19) Pareigos, (20) Bendrovė, (21) Parašas

lv : (1) EK atbilstības deklarācija (originals), (2) Ražotājs, (3) Adrese, (4) Tehniskās dokumentācijas turētājs, (5) Ražotāja apliecinā, ka turpmāk aprakstītā mašīna, (6) Atbilst tālāk norādītajām direktīvam un to iekļaušanai nacionālajā iekumdošanā (ja piemērojama), (7) IV pielikuma iekārtām, (8) Serifikācija numurs, (9) Pilnvarotā iestāde, (10) Piemērotā procedūra, (11) Skatāms jaudas līmenis, (12) Izmērīts, (13) Garantēts, (14) Piemērotajiem sašķaidītajiem standartiem, (15) Piemērotajām tehniskajiem standartiem un noteikumiem, (16) Sastādīts, (17) Datums, (18) Parakstītāja vārds, (19) Amats, (20) Uzņēmums, (21) Paraksts

mt : (1) Deklarazzjoni ta' Konformità tal-KE (originali), (2) Manifattur, (3) Indirizz, (4) Detentur tal-fajl tekniku, (5) Il-manifattur jiddeklara li l-magna descritta hawn taht, (6) Hija konformi hija konforma mad-Direttivi segwenti u l-hajjiet li jimpjebawhom fil-ligi nazzjonali (jekk applikabbli), (7) Għasli-magni li-Anness IV, (8) Numru tal-certifikat, (9) Entità notifikata, (10) Proċedura applikata, (11) Livell ta' qawwa akustika, (12) Imkejjel, (13) Garantit, (14) l-standards armonizzati użati, (15) standards tekniki u speċifikazzjonijiet oħra użati, (16) Magħmul f, (17) Data, (18) Isem il-firmatarju, (19) Kariga, (20) Kumpanija (21) Firma.

nl : (1) EG-vertaling van overeenstemming (oorspronkelijk), (2) Fabrikant, (3) Adres, (4) Houder van het technisch dossier, (5) De fabrikant verklaart dat de hieronder beschreven machine, (6) in overeenstemming is met de volgende richtlijn en hun omzettingen in het nationale recht (indien van toepassing), (7) Voor de machines in bijlage IV, (8) Certificatnummer, (9) Aangemelde instantie, (10) Toegestapete procedure, (11) Geluiscvermogensniveau, (12) Gemeten, (13) Gegarandeerd, (14) gehanteerde geharmoniseerde normen, (15) andere gehanteerde technische normen en specificaties, (16) Opgemaakt te, (17) Datum, (18) Naam van ondergetekende, (19) Functie, (20) Onderneming, (21) Handtekening.

no : (1) CE-samsvarerklæring (original), (2) Producent, (3) Adresse, (4) Innehaveren av den tekniske dokumentasjonen, (5) Produzenten sier at maskinen beskrevet nedenfor, (6) Oppfyller kravene i følgende direktiver og med nasjonale gjennomføringsbestemmelser (hvis aktuelt), (7) For maskinene i bilag IV, (8) Attestnummer, (9) Teknisk kontrollorgan, (10) Anvendt prosedyre, (11) Akustisk støy, (12) Målt, (13) Garantert, (14) harmoniserte standarder som brukes, (15) Andre standarder og spesifikasjoner som brukes, (16) Utstedt, (17) Dato, (18) Underlegnedes navn, (19) Stilling, (20) Firma (21) Underskrift.

pl : (1) Deklaracja zgodności CE (oryginał), (2) Producent, (3) Adres, (4) Posiadacz dokumentacji technicznej, (5) Producent oświadcza, że opisana poniżej maszyna, (6) Jest zgodna z następującymi dyrektywami i odpowiadającymi im przepisami prawa krajowego (jeśli dotyczy), (7) Dla maszyn załącznik IV, (8) Numer certyfikatu, (9) Jednostka certyfikująca, (10) Procedura stosowana, (11) Poziom mocy akustycznej, (12) Zmierzony, (13) Gwarantowany, (14) zastosowane normy zharmonizowane, (15) Zastosowane normy lub przepisy techniczne, (16) Sporządzono w, (17) Data, (18) Nazwisko podpisującego, (19) Stanowisko, (20) Firma (21) Podpis

pt : (1) Declaração de conformidade CE (original), (2) Fabricante, (3) Morada, (4) Titular do processo técnico, (5) O fabricante afirma que a máquina descrita abaixo, (6) Está em conformidade com as seguintes diretivas e as suas transposições para o direito nacional (se for o caso), (7) Para as máquinas no anexo IV, (8) Número de certificado, (9) Entidade notificada, (10) Procedimento aplicado, (11) Nível de potência acústica, (12) Medida, (13) Garantida, (14) Normas harmonizadas utilizadas, (15) outras normas e especificações técnicas utilizadas, (16) Elaborado em, (17) Data, (18) Nome do signatário, (19) Cargo, (20) Empresa, (21) Assinatura

ro : (1) Declarație de conformitate CE (original), (2) Producător, (3) Adresa, (4) Titularul din dosarul tehnic, (5) Producătorul afirmă că aparatul descris mai jos, (6) Este conform cu directivele următoare și cu transpunerea lor în dreptul național (dacă este cazul), (7) Pentru mașinile din anexa IV, (8) Număr de atestare, (9) Organism notificat, (10) Procedură aplicată, (11) Nivel de putere acustică, (12) Măsurat, (13) Garantat, (14) standardele armonizate utilizate, (15) alte standarde și specificații tehnice utilizate, (16) Intocmit în, (17) Data, (18) Numele persoanei care semnează, (19) Funcția, (20) Firma, (21) Semnătură

sk : (1) Vyhlásenie o zhode ES (pôvodní), (2) Výrobca, (3) Adresa, (4) Držitel technické dokumentácie, (5) Výrobca vyhlasuje, že nižšie popísaný stroj, (6) Je v súlade s nasledujúcimi smernicami a smernicami transponovanými do vnútroštátneho práva (v prípade potreby), (7) Pre stroje v prílohe IV, (8) Číslo certifikátu, (9) Notifikovaný orgán, (10) Použitý postup, (11) Akustická úroveň hluku, (12) Naměřená, (13) Zaručená, (14) Použité harmonizované normy, (15) Iné použité normy a technické predpisy, (16) Miesto vydania, (17) Dátum vydania, (18) Meno podpisanej osoby, (19) Funkcia, (20) Spoločnosť, (21) Podpis

sl : (1) ES izjava o skladnosti (izvirnik), (2) Proizvajalec, (3) Naslov, (4) Imetnik tehnične dokumentacije, (5) Proizvajalec izjavlja, da naprava, opisana v nadaljevanju, (6) Ustreza naslednjim smernicam in nacionalni zakonodaji (če ta velja), (7) Za stroje v skladu s prilogo IV, (8) Številka potrdila, (9) Priglasjen organ, (10) Uporabljen postopek, (11) Ravnan akustične moči, (12) Izmerjena, (13) Zajamčena, (14) Uporabljene usklajene standarde, (15) Drugi uporabljene tehnični standardi in specifikacije, (16) V, (17) Datum, (18) Ime podpisnika, (19) Funkcija, (20) Podjetje, (21) Podpis.

sv : (1) EÜ-förklaring om överensstämmelse (original), (2) Tillverkare, (3) Adress, (4) Ägaren av det tekniska underlaget, (5) Tillverkaren försäkras att den maskin som beskrivs nedan, (6) Överensstämmer med nedanstående direktiv och införlivandet av dem i nationell rätt (om tillämpligt), (7) För maskiner i bilaga IV, (8) Nummer för godkännande, (9) Anmänt organ, (10) Förfarande som tillämpats, (11) Ljudtrycksnivå, (12) Uppmätt, (13) Garanterad, (14) Harmoniserade standarder som använts, (15) andra tekniska standarder och specifikationer som använts, (16) Upprättat i, (17) Datum, (18) Namn på den som undertecknat, (19) Befattning, (20) Företag (21) Namnteckning

COMPONENT LOCATIONS

Note: front, rear, left and right are defined in OPERATING THE MACHINE: TRANSPORT/WORKING POSITION.

- 1- STANDARD PLATFORM WITHOUT GATE
- 2- STANDARD PLATFORM WITH GATE (OPTION)
- 3- NARROW PLATFORM WITHOUT GATE (OPTION)
- 4- STORAGE BOX
- 5- SLIDING MID RAIL
- 6- PLATFORM CONTROL PANEL
- 7- FOOT SWITCH
- 8- GATE
- 9- TELESCOPIC JIB ARM (ONLY FOR 280 TJ)
- 10- JIB ARM
- 11- TELESCOPIC ARM
- 12- MAIN ARM
- 13- TURNTABLE
- 14- TURNTABLE LOCKING PIN
- 15- RIGHT-HAND TURNTABLE COVER
- 16- GROUND LEVEL CONTROL PANEL
- 17- REMOTE CONTROL UNIT
- 18- HORN
- 19- ORANGE ROTATING BEACON LIGHT
- 20- LEFT-HAND TURNTABLE COVER
- 21- CHASSIS
- 22- REAR AXLE
- 23- DRIVING AND STEERING REAR WHEELS
- 24- OSCILLATING FRONT AXLE
- 25- DRIVING AND STEERING FRONT WHEELS
- 26- REAR CHASSIS COVER
- 27- FRONT CHASSIS COVER
- 28- RIGHT-HAND CHASSIS COVER
- 29- LEFT-HAND CHASSIS COVER



260 TJ+

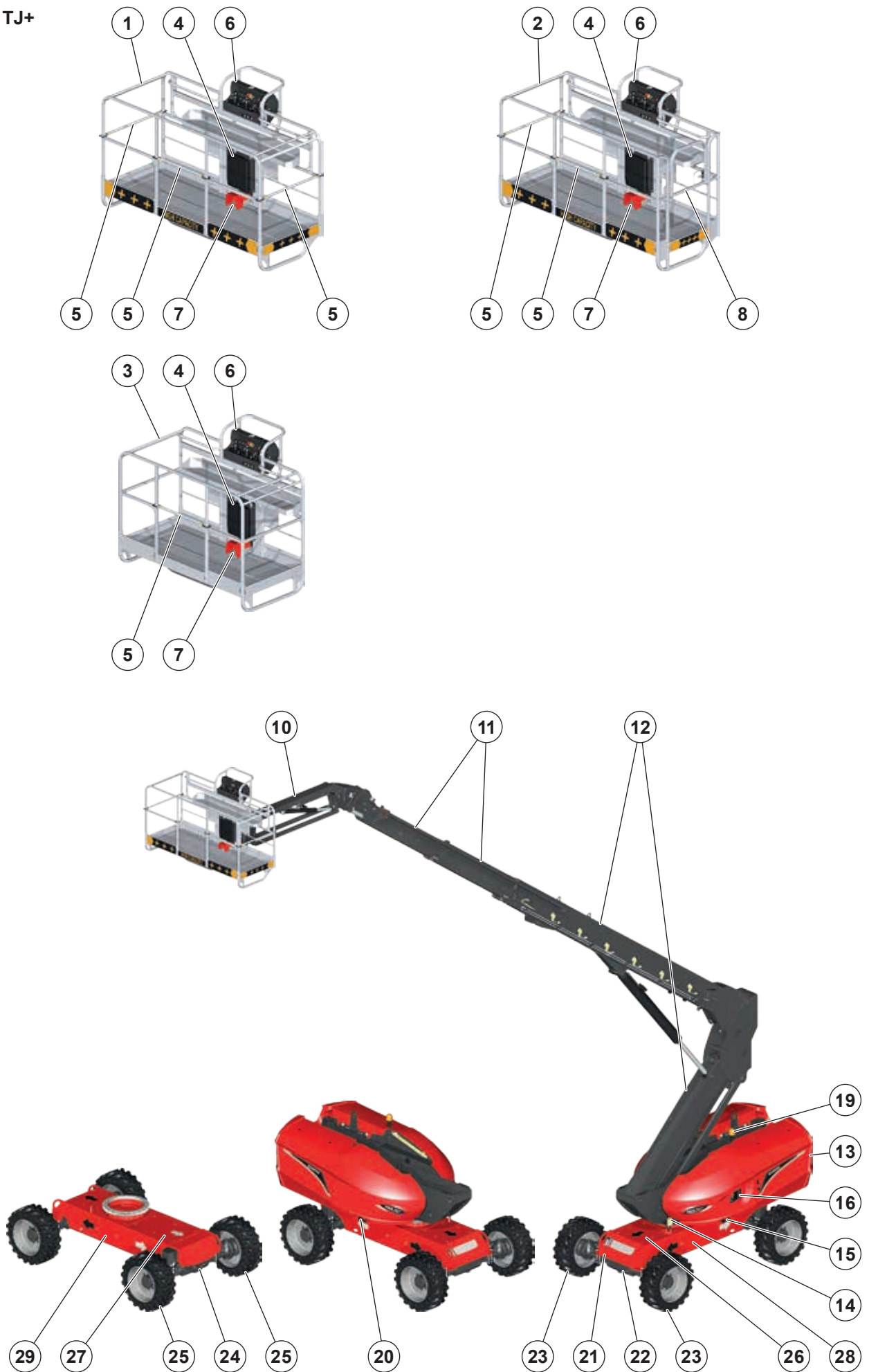

280 TJ

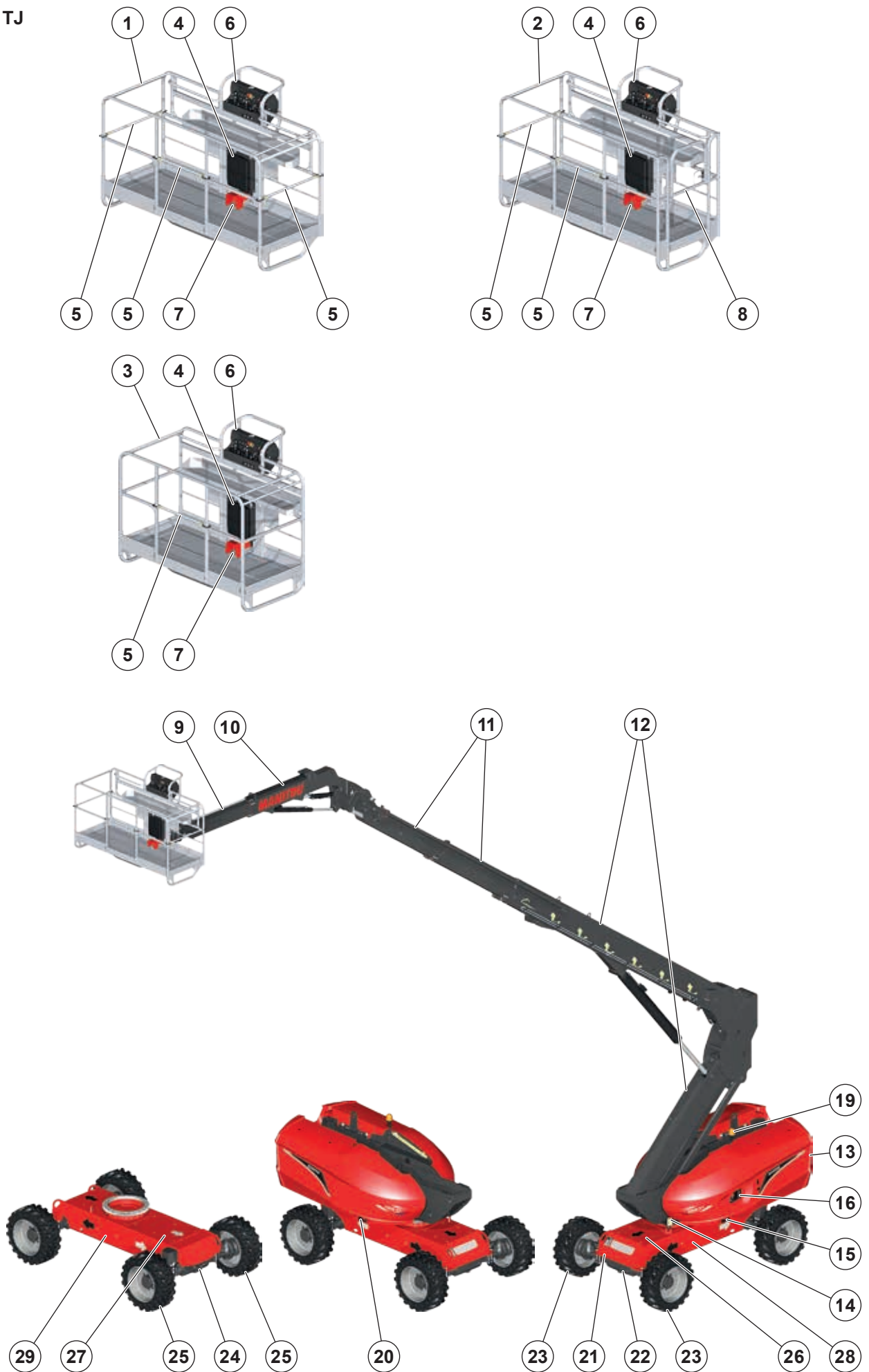

STICKERS

⚠ IMPORTANT ⚠

*Clean all the stickers so that they are legible.
Any stickers which are illegible or damaged must be replaced.
Check that the stickers are present after replacing any spare parts.*

Note: the illustrations show a standard platform without gate.

1- WHITE ARROW (STANDARD)	Part No. 833553	2-18
2- WHITE ARROW WITH BLACK OUTLINE (OPTION)	Part No. 52588045	2-18
3- BLACK ARROW	Part No. 833554	2-18
4- PLATFORM SAFETY INSTRUCTIONS 260 TJ+	Part No. 52718703	2-18
5- PLATFORM SAFETY INSTRUCTIONS 280 TJ	Part No. 318457	2-19
6- GROUND SAFETY INSTRUCTIONS	Part No. 685608	2-19
7- WHEEL LOAD	Part no. 52669277	2-19
8- DANGER OF CRUSHING HANDS	Part No. 676988	2-19
9- DANGER - KEEP AWAY	Part No. 679450	2-20
10- DANGER OF CRUSHING	Part No. 679452	2-20
11- DANGER ROTATING PART	Part No. 683108	2-20
12- DANGER HOT COMPONENT	Part No. 683112	2-20
13- WASHING INSTRUCTION	Part No. 313672	2-20
14- SAFETY HARNESS ATTACHMENT POINT	Part No. 834438	2-21
15- EMERGENCY STOP BUTTONS	Part No. 52669350	2-21
16- PLATFORM/JIB ARM TILT	Part No. 833523	2-21
17- PLATFORM/JIB ARM TILT AT ZERO	Part No. 52668403	2-21
18- X/Y FUNCTION	Part No. 52668443	2-21
19- BACKUP PUMP	Part No. 52658821	2-22
20- EMERGENCY CONTROL PROCEDURE	Part No. 833548	2-22
21- EMERGENCY CONTROL PROCEDURE	Part No. 833547	2-22
22- TURNTABLE LOCKING	Part No. 52673636	2-22
23- MACHINE FOLDING/UNFOLDING 260 TJ+	Part No. 52515335	2-23
24- MACHINE FOLDING/UNFOLDING 280 TJ	Part No. 833703	2-23
25- PLATFORM POSITION ON TRANSPORT VEHICLE	Part No. 52777530	2-23
26- ANCHORING POINT	Part No. 833041	2-23
27- ANCHORING 260 TJ+	Part No. 52685387	2-24
28- ANCHORING 280 TJ	Part No. 52686997	2-24
29- LIFTING POINT	Part No. 833291	2-24
30- LIFTING	Part No. 52686983	2-24
31- HYDRAULIC OIL	Part No. 597652	2-24
32- DIESEL FUEL	Part No. 305405	2-25
33- ANTIFREEZE	Part No. 52501046	2-25
34- BATTERY LOCATION	Part No. 52509705	2-25
35- POWER FUSES	Part No. 52571680	2-25
36- LIVE ELECTRICAL COMPONENTS	Part No. 52720522	2-25
37- REMOTE LUBRICATION	Part No. 834206	2-26
38- TELESCOPIC ARM CABLE ADJUSTMENT	Part No. 833559	2-26
39- FAULT CODES	Part No. 52668056	2-26
40- CHASSIS HYDRAULIC BLOCK COILS	Part No. 833702	2-26
41- TURNTABLE HYDRAULIC BLOCK COILS	Part No. 52695543	2-26
42- JIB ARM HYDRAULIC BLOCK COILS AND PLATFORM/JIB ARM TILT ANGLE SENSORS 260 TJ+	Part No. 52568744	2-27
43- JIB ARM HYDRAULIC BLOCK COILS AND PLATFORM/JIB ARM TILT ANGLE SENSORS 280 TJ	Part No. 834211	2-27
44- TURNTABLE ROTATION SENSORS	Part No. 833688	2-27
45- MAIN ARM ANGLE SENSORS	Part No. 833696	2-27
46- TELESCOPIC ARM SENSORS 260 TJ+	Part No. 52523378	2-27
47- TELESCOPIC ARM SENSORS 280 TJ	Part No. 833697	2-28
48- OVERLOAD SENSORS 260 TJ+	Part No. 52718709	2-28
49- OVERLOAD SENSORS 280 TJ	Part No. 833694	2-28

50- BATTERY CUT-OFF (OPTION).....	Part No. 598894	2-28
51- HYDRAULIC OIL HEATER (OPTION)	Part No. 52633500	2-28
52- ENGINE BLOCK HEATER (OPTION)	Part No. 233088	2-29
53- ENGINE BLOCK HEATER (OPTION)	Part No. 831342	2-29
54- BATTERY HEATER (OPTION)	Part No. 52633504	2-29
55- 230 V ELECTRICAL SYSTEM (OPTION)	Part No. 518548	2-29
56- 230 V ELECTRICAL SYSTEM (OPTION)	Part No. 832461	2-30
57- 110 V ELECTRICAL SYSTEM (OPTION)	Part No. 314681	2-30
58- ELECTRICAL HAZARD (OPTION).....	Part No. 678451	2-30

260 TJ+



280 TJ



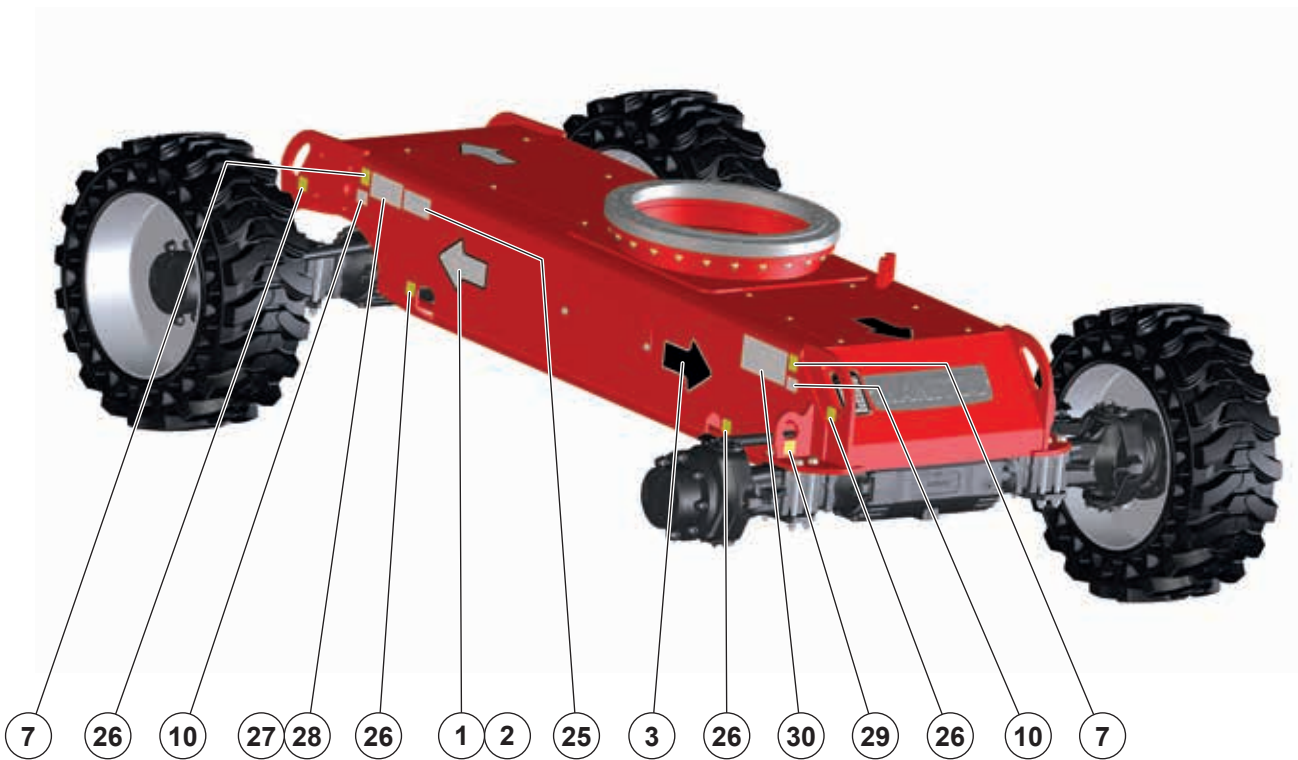
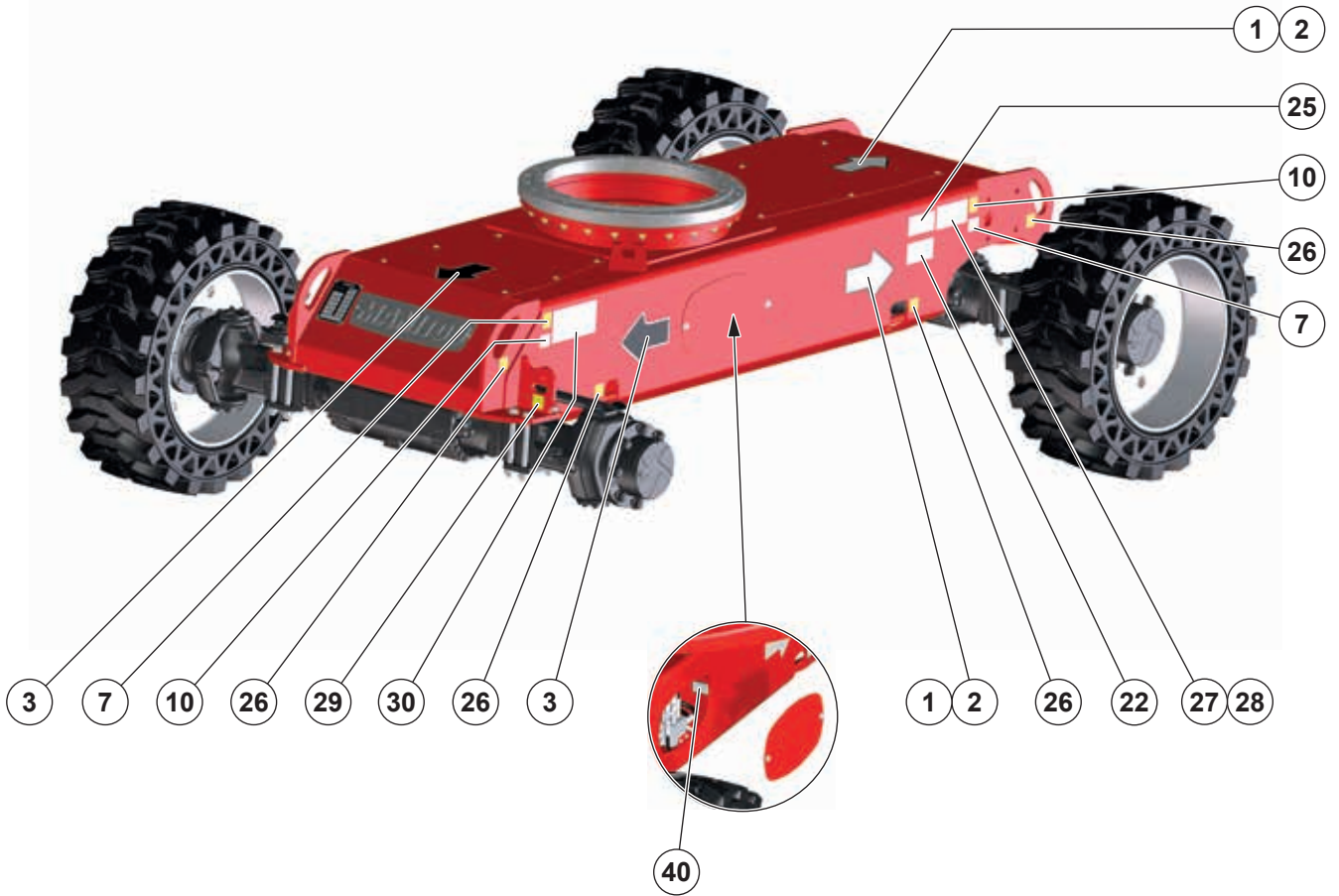

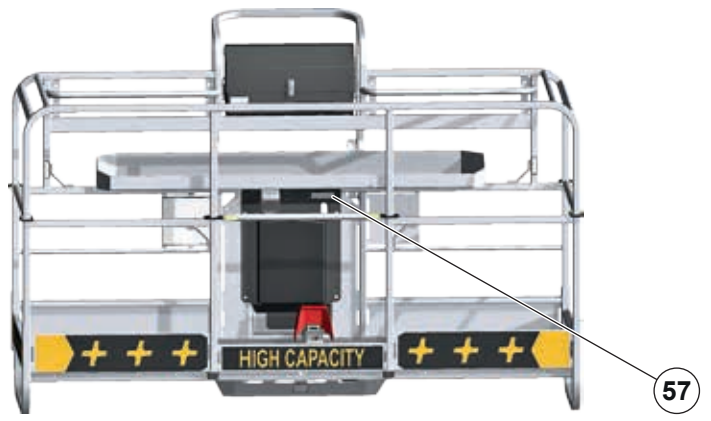
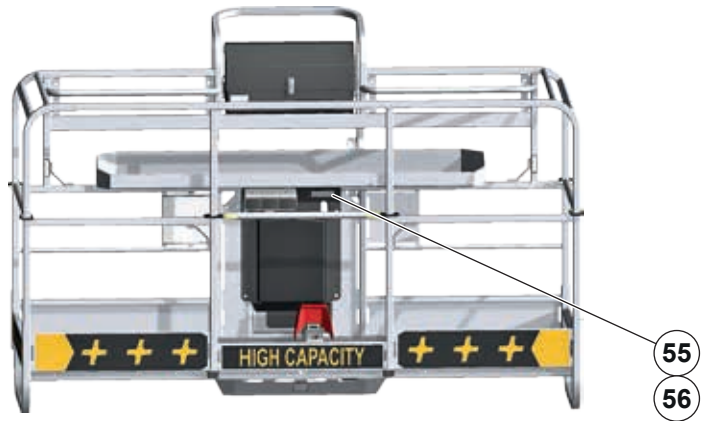
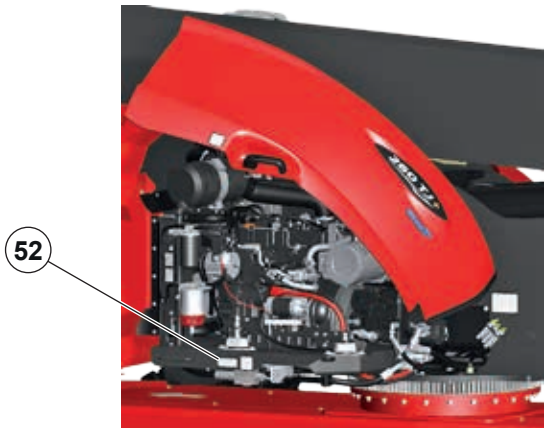
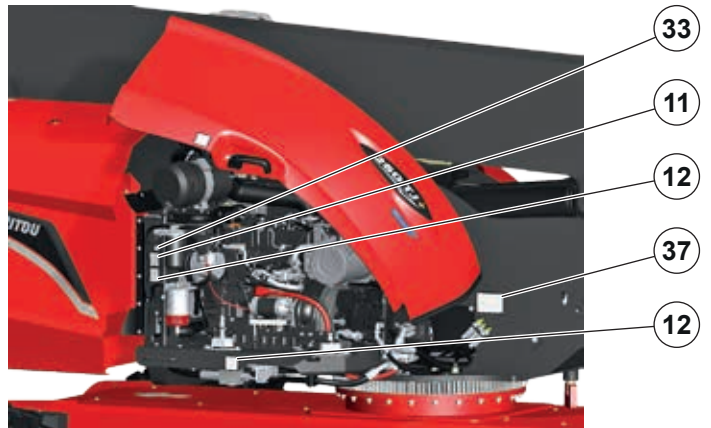
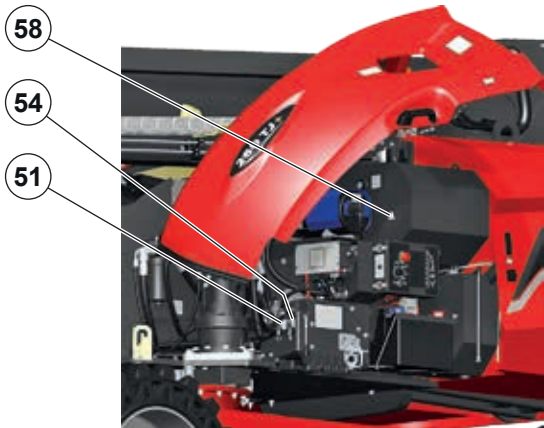
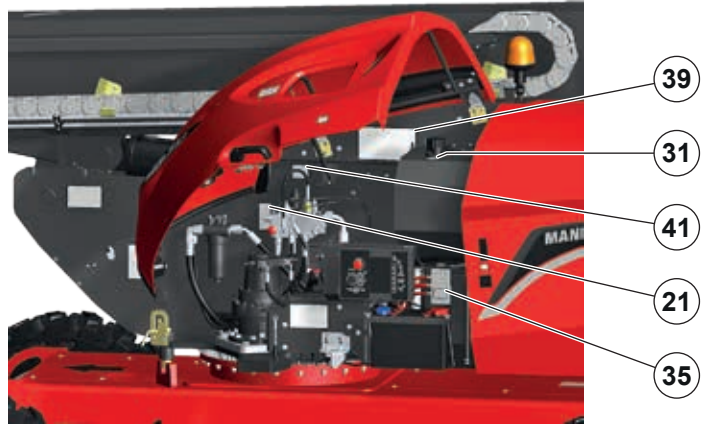
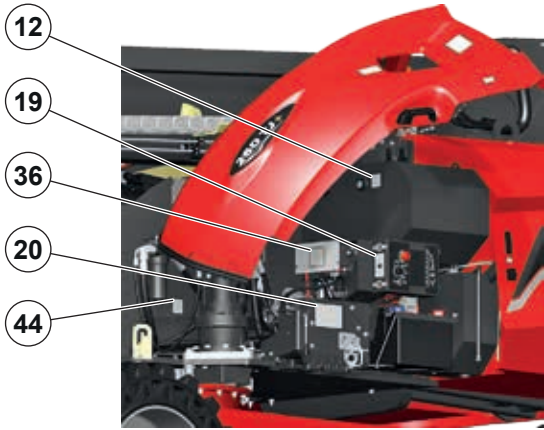

Note: the illustrations show a 260 TJ+.

1- WHITE ARROW (STANDARD)

Part No. 833553

Indicates the forward direction of travel when the turntable and the platform are in neutral position, OPERATING THE MACHINE: TRANSPORT/WORKING POSITION.

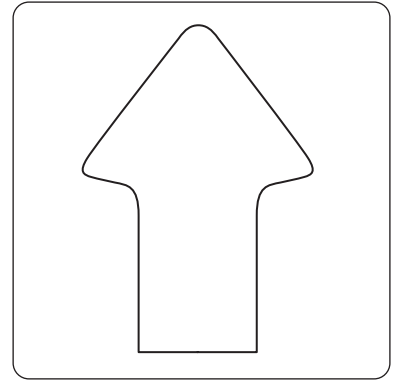

2- WHITE ARROW WITH BLACK OUTLINE (OPTION)

Part No. 52588045

Indicates the forward direction of travel when the turntable and the platform are in neutral position, OPERATING THE MACHINE: TRANSPORT/WORKING POSITION.

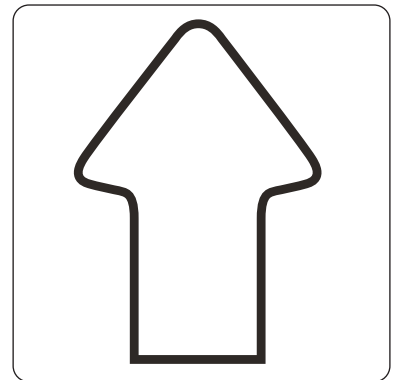

3- BLACK ARROW

Part No. 833554

Indicates the backward direction of travel when the turntable and the platform are in neutral position, OPERATING THE MACHINE: TRANSPORT/WORKING POSITION.

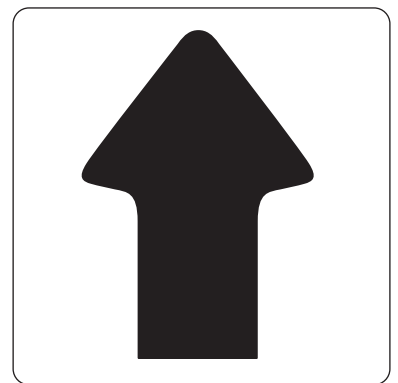

4- PLATFORM SAFETY INSTRUCTIONS 260 TJ+

Part No. 52718703

Indicates:

- ① That the instruction manual must be read and understood before using the machine.
- ② Whether the machine can be operated outside and inside.
- ③ The maximum manual force.
- ④ The maximum load capacity in the platform.
- ⑤ The maximum wind speed when operating outside.
- ⑥ Maximum chassis tilt in working position.
- ⑦ The risk of electric shock.
- ⑧ The machine's amplitude of movement.

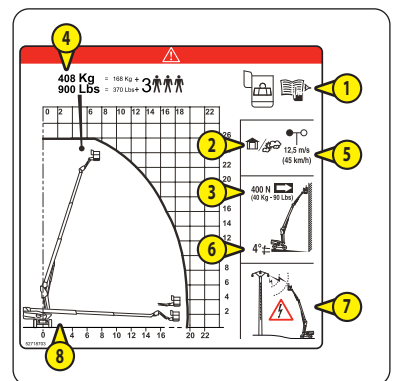

5- PLATFORM SAFETY INSTRUCTIONS 280 TJ

Part No. 318457

Indicates:

- ① That the instruction manual must be read and understood before using the machine.
- ② Whether the machine can be operated outside and inside.
- ③ The maximum manual force.
- ④ The maximum load capacity in the platform.
- ⑤ The maximum wind speed when operating outside.
- ⑥ Maximum chassis tilt in working position.
- ⑦ The risk of electric shock.
- ⑧ The machine's amplitude of movement.

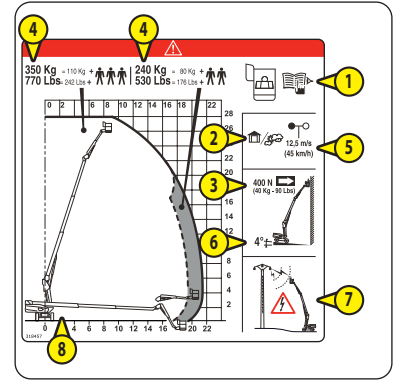

6- GROUND SAFETY INSTRUCTIONS

Part No. 685608

Indicates:

- ① That the instruction manual must be read and understood before using the machine.
- ② That the machine must not be towed in the event of breakdown.
- ③ It is strictly forbidden to direct a pressure washer nozzle over the control panels and electrical components.

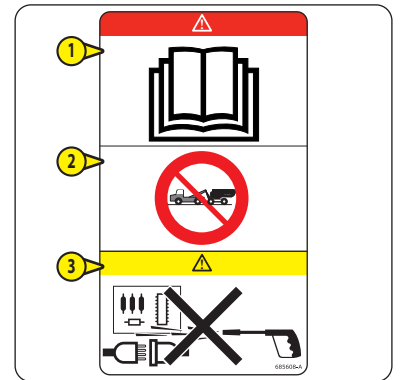

7- WHEEL LOAD

Part no. 52669277

Indicates the maximum ground load per wheel.

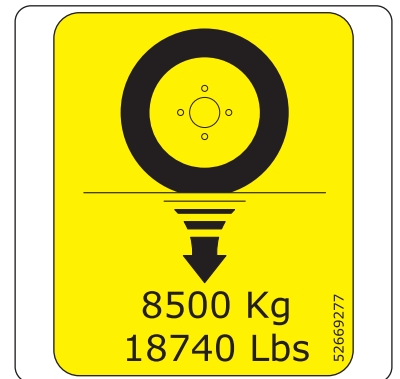

8- DANGER OF CRUSHING HANDS

Part No. 676988

Indicates that it is strictly forbidden to place your hands or any other part of the body in the lifting mechanism components.



9- DANGER - KEEP AWAY

Part No. 679450

Indicates that it is strictly forbidden to stand under the lifting mechanism or within the machine's working area.



10- DANGER OF CRUSHING

Part No. 679452

Indicates that it is strictly prohibited to stand in this area when the machine is moving. The components on which this sticker is affixed could crush you.



11- DANGER ROTATING PART

Part No. 683108

Indicates that there is a high risk of severing fingers with the radiator fan.



12- DANGER HOT COMPONENT

Part No. 683112

Indicates that there is a high risk of burns in the vicinity.



13- WASHING INSTRUCTION

Part No. 313672

Indicates that it is strictly forbidden to direct a high pressure cleaner nozzle over the control panels and electrical components or on the diesel engine air intake.

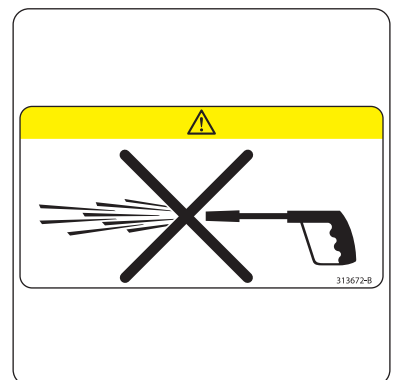

14- SAFETY HARNESS ATTACHMENT POINT

Part No. 834438

Indicates the location of the safety harness attachment points, SAFETY COMPONENTS: SAFETY HARNESS ATTACHMENT POINTS.



15- EMERGENCY STOP BUTTONS

Part No. 52669350

Indicates the location of the machine's emergency stop buttons.

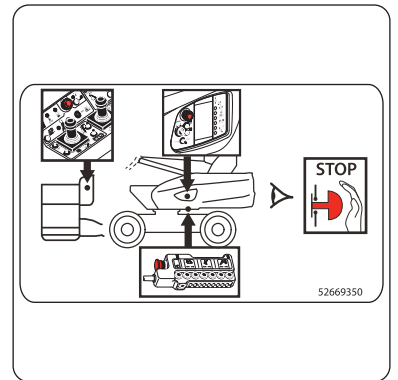

16- PLATFORM/JIB ARM TILT

Part No. 833523

Indicates the platform/jib arm tilt, CONTROL PANEL AND SAFETY DEVICES IN THE PLATFORM: PLATFORM/JIB ARM TILT BUTTON.

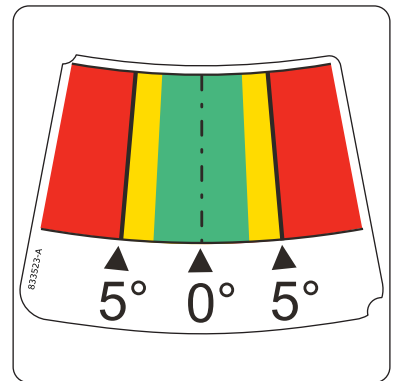

17- PLATFORM/JIB ARM TILT AT ZERO

Part No. 52668403

Indicates the procedure to follow to reset the platform/jib arm tilt to zero, CONTROL PANEL AND SAFETY DEVICES IN THE PLATFORM: PLATFORM/JIB ARM TILT BUTTON.

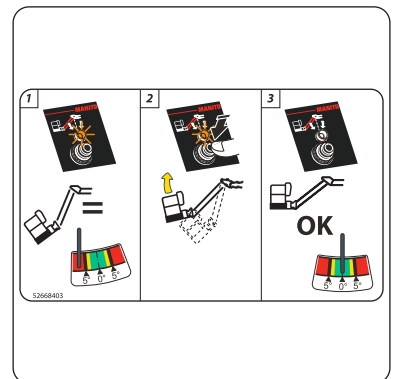

18- X/Y FUNCTION

Part No. 52668443

Indicates the procedures to follow the use the X and Y functions, CONTROL PANEL AND SAFETY DEVICES IN THE PLATFORM: X/Y FUNCTION BUTTON.

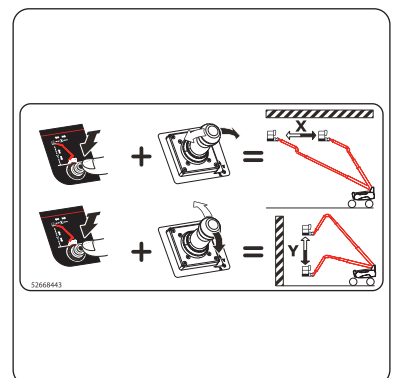

19- BACKUP PUMP

Part No. 52658821

Indicates the procedure to be followed for using the backup pump,  EMERGENCY CONTROLS.



20- EMERGENCY CONTROL PROCEDURE

Part No. 833548

Indicates the procedure to be followed for using the emergency controls for the proportional distributor,  EMERGENCY CONTROLS.



21- EMERGENCY CONTROL PROCEDURE

Part No. 833547

Indicates the procedure to follow for using the backup valve,  EMERGENCY CONTROLS.

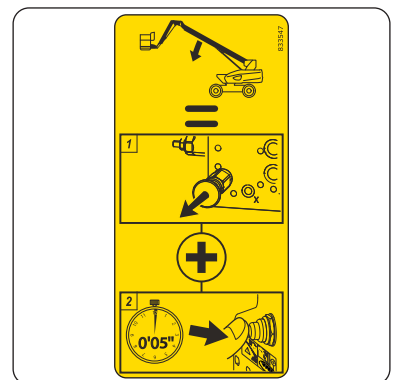

22- TURNTABLE LOCKING

Part No. 52673636

Indicates:

- ① That the instruction manual should be consulted before loading the machine onto a vehicle and before unloading it.
- ② That the turntable must be locked before loading the platform onto a vehicle, before unloading it and once it is on the vehicle.
- ③ That turntable rotation is prohibited once on the transport vehicle.

Note:  TRANSPORT AND LIFTING: TRANSPORT INSTRUCTIONS.

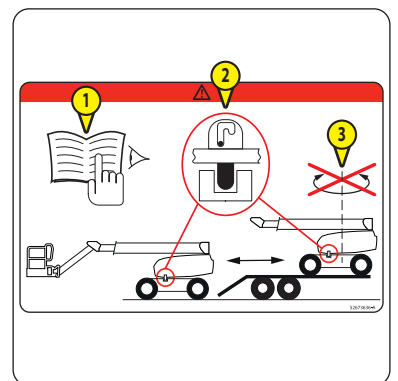

23- MACHINE FOLDING/UNFOLDING 260 TJ+

Part No. 52515335

Indicates:

- ① ② ③ The procedure for folding the machine.
- ⑤ ④ ⑥ The procedure for unfolding the machine.
- ⑦ That the turntable must be locked once the machine is on the vehicle.
- ⑧ That the machine must be in the folded position to be secured to the vehicle.
- ⑨ That the platform must not be in contact with the floor of the transport vehicle when the machine is folded.

Note: ⚠ TRANSPORT AND LIFTING: TRANSPORT INSTRUCTIONS.

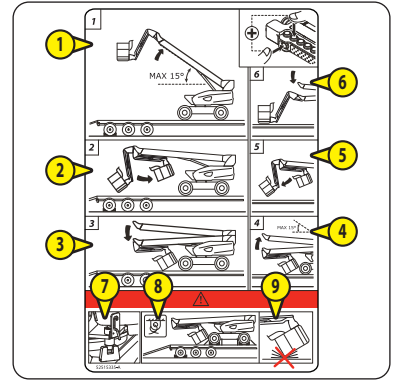

24- MACHINE FOLDING/UNFOLDING 280 TJ

Part No. 833703

Indicates:

- ① ② ③ ④ The procedure for folding the machine.
- ⑤ ⑥ ⑦ ⑧ The procedure for unfolding the machine.
- ⑨ That the turntable must be locked once the machine is on the vehicle.
- ⑩ That the machine must be in the folded position to be secured to the vehicle.
- ⑪ That the platform must not be in contact with the floor of the transport vehicle when the machine is folded.

Note: ⚠ TRANSPORT AND LIFTING: TRANSPORT INSTRUCTIONS.

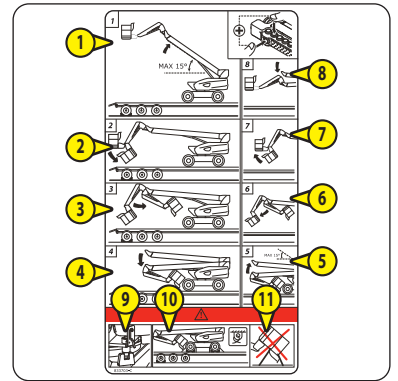

25- PLATFORM POSITION ON TRANSPORT VEHICLE

Part No. 5277530

Indicates that it is strictly forbidden to rest the platform on the bed of the transport vehicle when loading the machine, ⚠ OPERATING THE MACHINE: TRANSPORTING THE MACHINE.

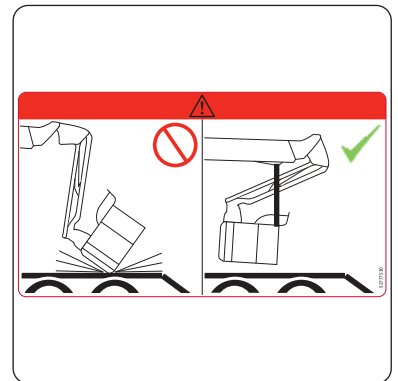

26- ANCHORING POINT

Part No. 833041

Indicates the location of the machine's anchoring points, ⚠ TRANSPORT AND LIFTING: TRANSPORT INSTRUCTIONS.

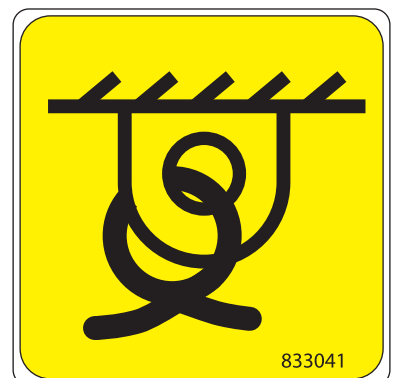

27- ANCHORING 260 TJ+

Part No. 52685387

Indicates the main features that are useful when anchoring the machine, TRANSPORT AND LIFTING: TRANSPORT INSTRUCTIONS.

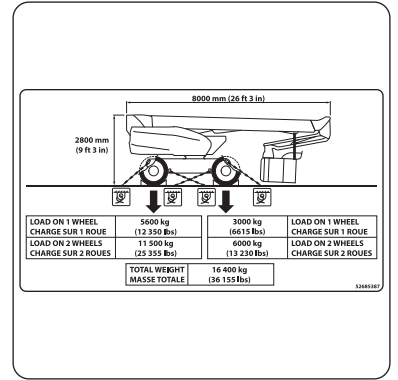

28- ANCHORING 280 TJ

Part No. 52686997

Indicates the main features that are useful when anchoring the machine, TRANSPORT AND LIFTING: TRANSPORT INSTRUCTIONS.

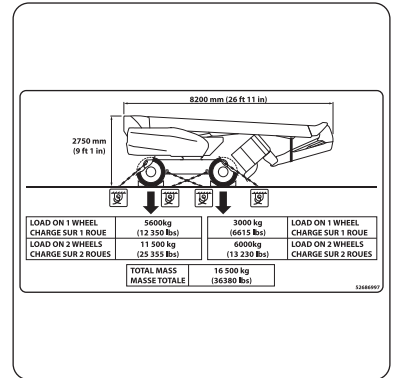

29- LIFTING POINT

Part No. 833291

Indicates the location of the machine's lifting points, TRANSPORT AND LIFTING: LIFTING INSTRUCTIONS.

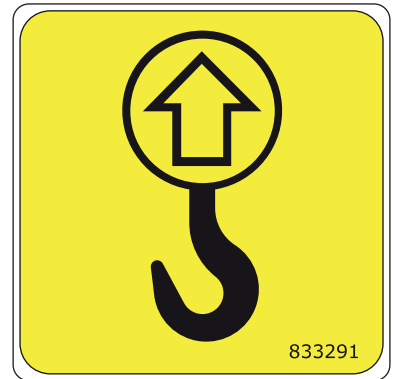

30- LIFTING

Part No. 52686983

Indicates:

- 1 That the instruction manual must be consulted before lifting the machine.
- 2 That the turntable must be locked during lifting of the machine.
- 3 The main features that are useful when lifting the machine.

Note: TRANSPORT AND LIFTING: LIFTING INSTRUCTIONS.

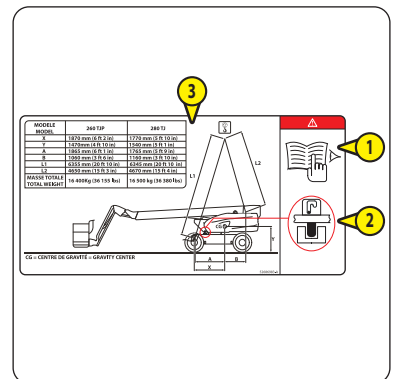

31- HYDRAULIC OIL

Part No. 597652

This indicates that the tank is intended to contain only hydraulic oil.

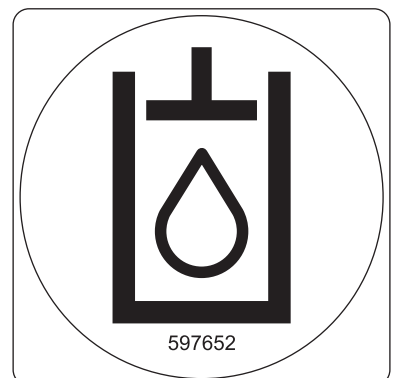

32- DIESEL FUEL

Part No. 305405

Indicates that the tank is intended to contain only diesel fuel with a low sulfur content.

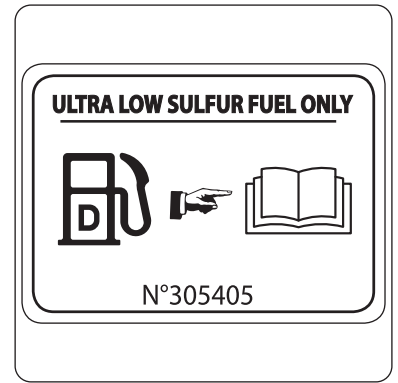

33- ANTIFREEZE

Part No. 52501046

Indicates that there is antifreeze in the diesel engine radiator.

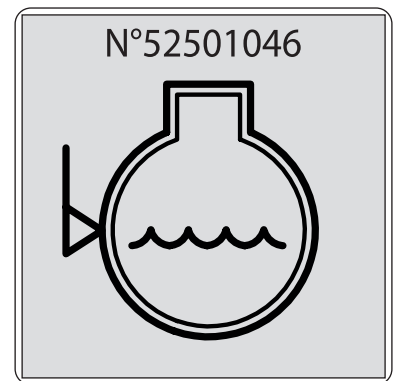

34- BATTERY LOCATION

Part No. 52509705

Indicates location of battery.

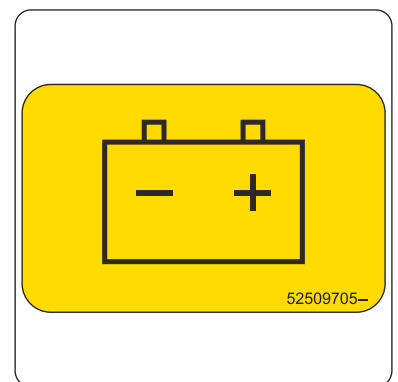

35- POWER FUSES

Part No. 52571680

Indicates the location, amperage and allocation of power fuses.

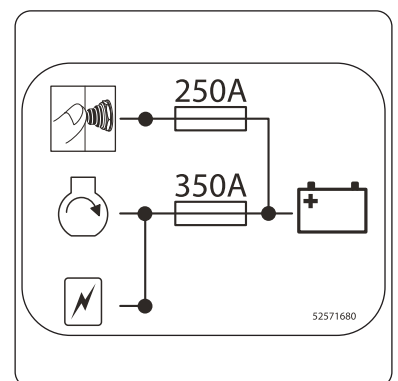

36- LIVE ELECTRICAL COMPONENTS

Part No. 52720522

Indicates that certain electrical components remain live even when the battery cut-off (option) is in the OFF position.

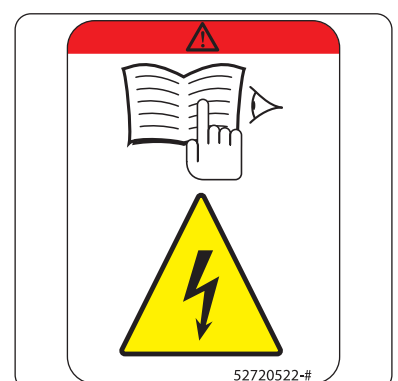

37- REMOTE LUBRICATION

Part No. 834206

Indicates the location and intended use of the remote lubricators for lubricating the turntable ring gear and the lifting structure.

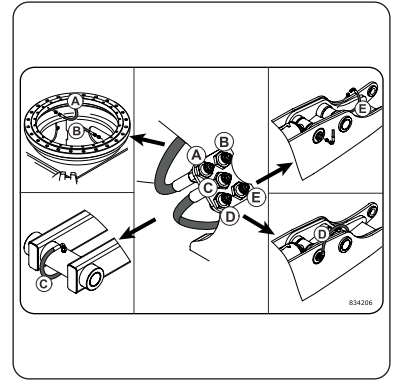

38- TELESCOPIC ARM CABLE ADJUSTMENT

Part No. 833559

Indicates the procedure to follow to adjust the tension of the telescopic arm cables.

Note: this sticker is not visible to the operator, only maintenance personnel can see it by removing a cover.

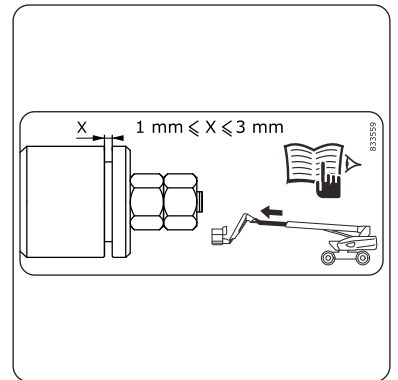

39- FAULT CODES

Part No. 52668056

Indicates the fault codes and location of the electrical components:

- Sensors (AS, DS, IS, TS).
- Solenoid valves (EV).
- Solenoid coils (EW).

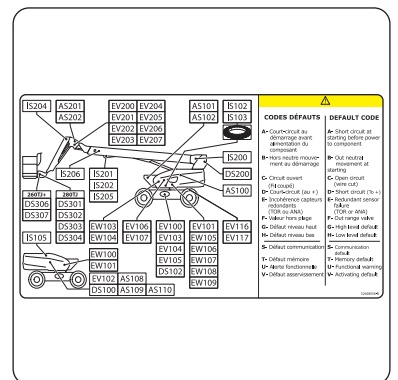

40- CHASSIS HYDRAULIC BLOCK COILS

Part No. 833702

Indicates the location and fault codes of the chassis hydraulic block coils.

Note: this sticker is not visible to the operator, only maintenance personnel can see it by removing a cover.

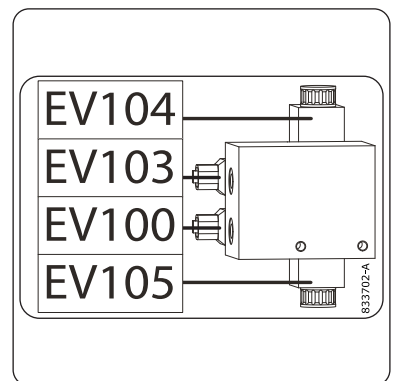

41- TURNTABLE HYDRAULIC BLOCK COILS

Part No. 52695543

Indicates the location and fault codes of the turntable hydraulic block coils.

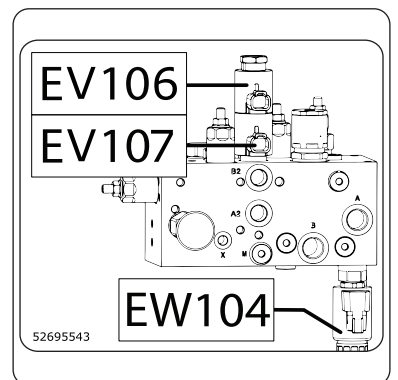

42- JIB ARM HYDRAULIC BLOCK COILS AND PLATFORM/JIB ARM TILT ANGLE SENSORS

260TJ+

Part No. 52568744

Indicates the location and fault codes of the jib arm hydraulic block coils and the platform/jib arm tilt angle sensors.

Note: this sticker is not visible to the operator, only maintenance personnel can see it by removing a cover.

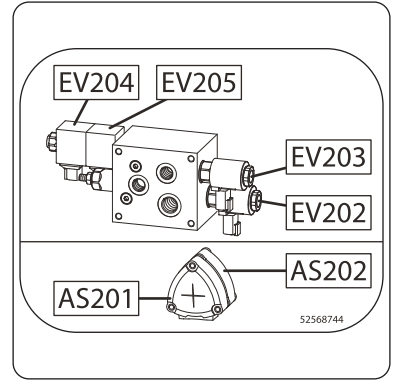

43- JIB ARM HYDRAULIC BLOCK COILS AND PLATFORM/JIB ARM TILT ANGLE SENSORS

280TJ

Part No. 834211

Indicates the location and fault codes of the jib arm hydraulic block coils and the platform/jib arm tilt angle sensors.

Note: this sticker is not visible to the operator, only maintenance personnel can see it by removing a cover.

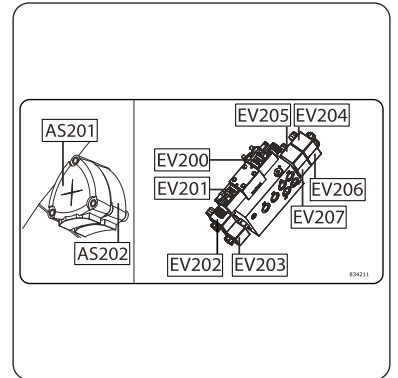

44- TURNTABLE ROTATION SENSORS

Part No. 833688

Indicates the location and fault codes of the turntable rotation sensors.

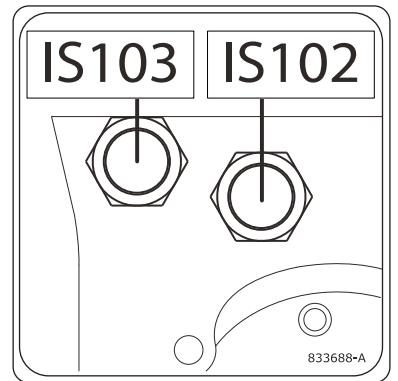

45- MAIN ARM ANGLE SENSORS

Part No. 833696

Indicates the location and fault codes of the main arm angle sensors.

Note: this sticker is not visible to the operator, only maintenance personnel can see it by removing a cover.

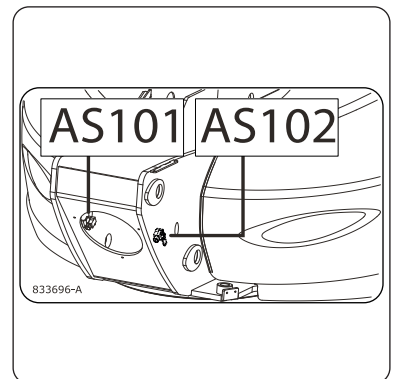

46- TELESCOPIC ARM SENSORS

260TJ+

Part No. 52523378

Indicates the location and fault codes of the telescopic arm sensors.

Note: this sticker is not visible to the operator, only maintenance personnel can see it by removing a cover.

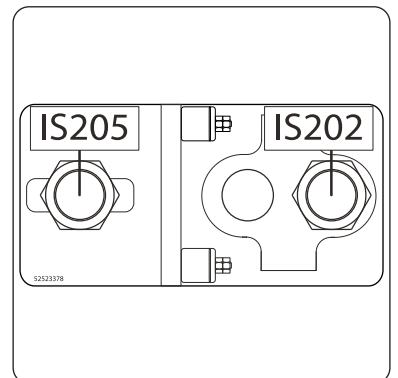

47- TELESCOPIC ARM SENSORS 280 TJ

Part No. 833697

Indicates the location and fault codes of the telescopic arm sensors.

Note: this sticker is not visible to the operator, only maintenance personnel can see it by removing a cover.

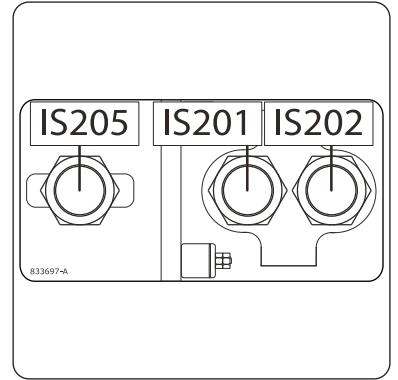

48- OVERLOAD SENSORS 260 TJ+

Part No. 52718709

Indicates the location and fault codes of the overload sensors.

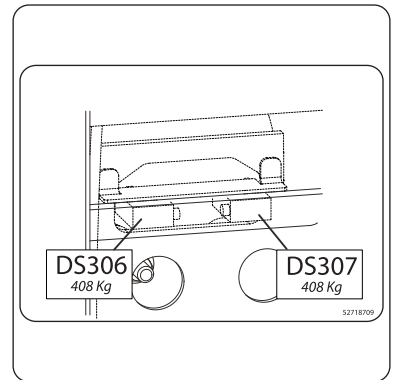

49- OVERLOAD SENSORS 280 TJ

Part No. 833694

Indicates the location and fault codes of the overload sensors.

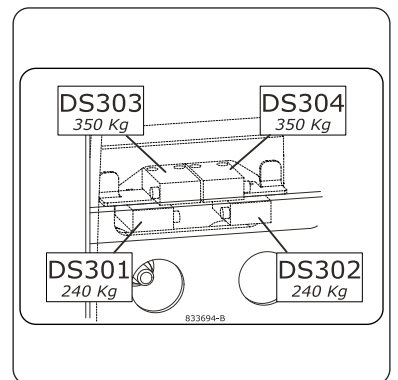

50- BATTERY CUT-OFF (OPTION)

Part No. 598894

Indicates the location, the off position "OFF" and the on position "ON" of the battery cut-off.

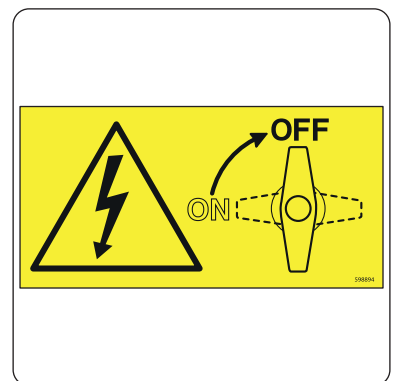

51- HYDRAULIC OIL HEATER (OPTION)

Part No. 52633500

Indicates:

- The location of the hydraulic oil heater plug.
- ① That the diesel engine must be stopped and that the instruction manual should be consulted before connecting the hydraulic oil heater.
- ② The voltage of the power source.

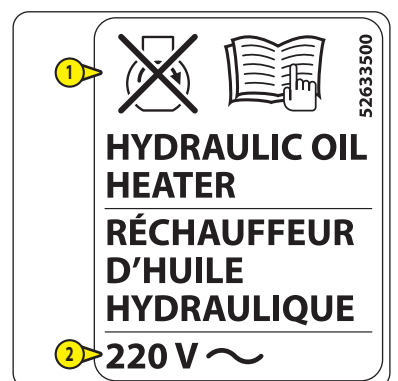

52- ENGINE BLOCK HEATER (OPTION)

Part No. 233088

Indicates:

- The location of the engine block heater.
- ① The voltage, the amperage and the frequency of the power source.
- ② That the instruction manual must be consulted before connecting the engine block heater.

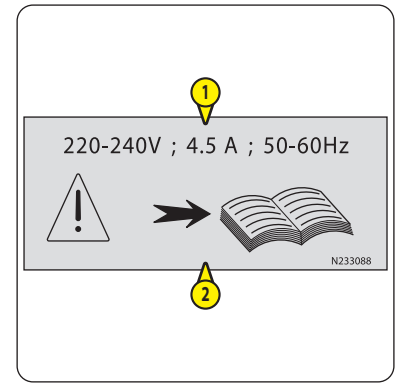

53- ENGINE BLOCK HEATER (OPTION)

Part No. 831342

Indicates:

- The location of the engine block heater plug.
- ① The voltage and the amperage of the power source and that the electrical system is protected by a 30 mA residual-current circuit breaker.
- ② That the diesel engine must be stopped before connecting the engine block heater.

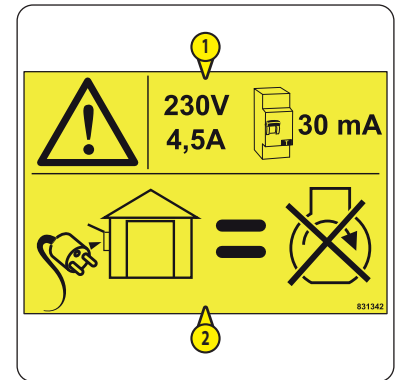

54- BATTERY HEATER (OPTION)

Part No. 52633504

Indicates:

- The location of the battery heater plug.
- ① That the diesel engine must be stopped and that the instruction manual should be consulted before connecting the battery heater.
- ② The voltage of the power source.

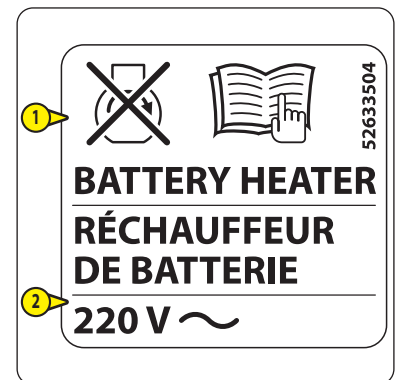

55- 230 V ELECTRICAL SYSTEM (OPTION)

Part No. 518548

Indicates:

- ① The voltage and the amperage of the power source.
- ② That the electrical system is protected by a 30 mA residual-current circuit breaker.
- ③ The cross-section of the cables in the electrical system.

Note:

- For 230 V electric power socket option in the platform (quantity = 2)
- For 230 V 3.5 kW electric generator option (quantity = 1).

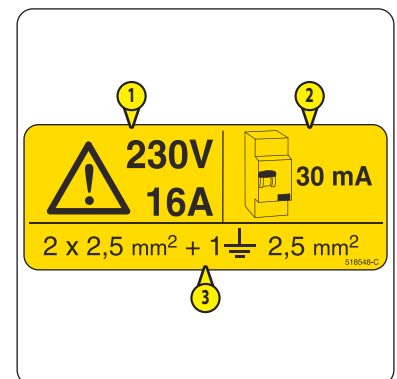

56- 230 V ELECTRICAL SYSTEM (OPTION)

Part No. 832461

Indicates:

- ① The voltage and the amperage of the electrical system.
- ② That the electrical system is protected by a 30 mA residual-current circuit breaker.
- ③ The maximum power delivered by all 3 sockets.

Note:

- For 230 V 5 kW electric generator option (quantity = 1).

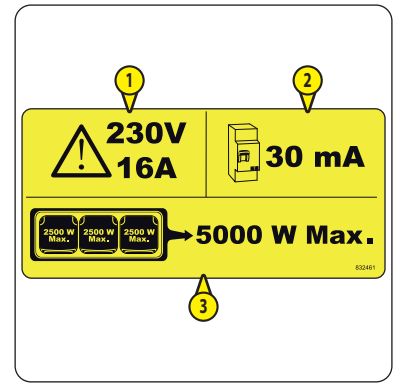

57- 110 V ELECTRICAL SYSTEM (OPTION)

Part No. 314681

Indicates:

- ① The voltage and the amperage of the electrical system.
- ② That the electrical system is protected by a 30 mA residual-current circuit breaker.
- ③ The cross-section of the cables in the electrical system.

Note: for 110 V 3.5 kW electric generator option.

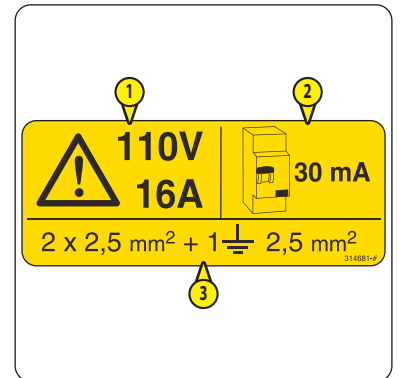

58- ELECTRICAL HAZARD (OPTION)



Part No. 678451

Indicates an electrical hazard.

Note:

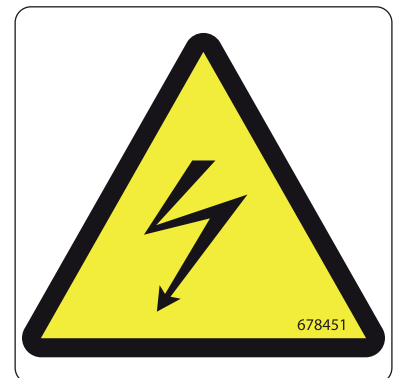
- For 110 V 3.5 kW electric generator option.
- For 230 V 3.5 kW electric generator option.
- For 230 V 5 kW electric generator option.



GENERAL CHARACTERISTICS			±
Machine			
- Maximum load capacity the platform.	kg (lbs)	408 (900) (1)	-
- Maximum wind speed when operating outside	km/h	45	-
- Maximum number of people in the platform (indoor use/ outdoor use)		3 / 3 (1)	-
- Machine weight, unladen	kg (lbs)	16400 (36156)	2%
- Maximum authorized chassis tilt in working position	°	4	0.1%
- Maximum slope in transport position:			
1- Platform at the bottom of the slope with 100 kg (220 lbs) in the platform (maximum slope accessible)	 %	35	2
2- Platform at the top of the slope	 %	15	-
3- Lateral slope	 %	15	-
- Maximum manual force	N	400	-
Wheels			
- Load on one front wheel (transport position)	kg (lbs)	5600 (12350)	2%
- Load on one rear wheel (transport position)	kg (lbs)	3000 (6615)	2%
- Maximum load on one wheel (working position)	kg (lbs)	6930 (15280)	2%
- Bearing surface on ground (hard/soft)	cm ²	446 / 1125	5%
- Ground bearing pressure (hard/soft)	daN/cm ²	21.3 / 8.44	5%
(1) Pipe support attachment or panel support attachment not installed, ↖ 4-ATTACHMENTS for the specific values when an attachment is installed.			

SPEEDS AND MOVEMENTS			±
Travel speeds			
- Working speed	km/h	0.8	0.1
- Reduced speed	km/h	1.8	-
- Slow speed	km/h	2.5	0.5
- Ramp speed	km/h	2.5	0.2
- Hare speed	km/h	4.5	0.2
Main arm (telescopic arm extended)			
- Lifting speed (unladen/laden)	s	70 / -	5
- Lowering speed (unladen/laden)	s	70 / -	5
Main arm (telescopic arm retracted)			
- Lifting speed (unladen/laden)	s	42 / -	5
- Lowering speed (unladen/laden)	s	42 / -	5
Telescopic arm			
- Extended (unladen/laden)	s	30 / -	5
- Retracted (unladen/laden)	s	30 / -	5
Jib arm			
- Lifting speed (unladen/laden)	s	22 / -	5
- Lowering speed (unladen/laden)	s	18 / -	5
Turntable			
- 90° rotation (telescopic arm extended/retracted/retracted and main arm raised)	s	50/30/28	5
Platform			
- Rotation to the right / to the left	s	7 / 7	2.5

DIESEL ENGINE			±
Type		YANMAR 4TNV88C	-
Fuel		Diesel	-
Number of cylinders		4	-
Displacement	cm ³	2190	-
Idling speed unladen	rpm	950	50
Maximum speed unladen	rpm	2800	50
Power at 2800 rpm	kW	34.3	-
Maximum torque at 1820 rpm	N.m	128	-
Unladen weight	kg (lbs)	205 (452)	5 (11)
Type of cooling		Coolant	-
Fan		Suction	-
Emissions			
- CO (carbon monoxide)	g/kWh	0.265	-
- CO2 (carbon dioxide)	g/kWh	838	-
- HC + Nox (hydrocarbons + nitrogen dioxide)	g/kWh	2.881	-
- PT (particles)	g/kWh	0.0068	-

TRANSMISSION			±
Hydrostatic pump			
- Type		BOSCH REXROTH	-
- Maximum cylinder capacity	cm ³	56	-
- Maximum unladen flow rate	L/min	168	-
- Maximum pressure	bar	400	-
Hydrostatic motor			
- Type		PARKER	-
- Displacement	cm ³	125	-
Axles			
- Type		DANA SPICER	-
- Reduction ratio		47.12	-
- Tractive force	daN	5850	-
- Front axle differential		45% limited slip	-
- Rear axle differential		100% hydraulic locking	-
Front / rear steering/directional wheels		2 / 2	-
Front / rear drive wheels		2 / 2	-
Wheels			
- Type		SOLIDEAL SOLIDAIR AWP	-
- Dimensions (external Ø x width)	mm	1025 x 365	-
- Inflation		Solid tire	-

BRAKES			±
Type		Negative	-
Type of order		Hydraulics	-
Front/rear braked wheels		2 / 2	-
Brake release (freewheeling)		Manual	-
Braking torque	daN.m	3100 on wheel	5%

HYDRAULIC CIRCUIT			±
Auxiliary hydraulic pump			
- Type		BOSCH REXROTH	-
- Maximum cylinder capacity	cm ³	28	-
- Maximum unladen flow rate	L/min	70	-
Control valve			
- Type		DANFOSS	-
- Maximum pressure	bar	240	5
Turntable rotation motor			
- Type		BONFIGLIOLI	-
- Reduction ratio		1: 24.5	-
Filtration			
- Suction	µm	125	-
- Pressure	µm	10	-
- Operation	µm	10	-

ELECTRIC CIRCUIT			±
Battery (original equipment)			
- Type		EXIDE	-
- Capacity C5	Ah	145	-
- Capacity C20	Ah	-	-
- Rated voltage	V	12	-
Alternator			
- Type		DENSO	-
- Maximum amperage	A	55	-
- Rated voltage	V	12	-
Starter			
- Type		HITACHI	-
- Power	kW	2.3	-
- Voltage	V	12	-

BACKUP PUMP			±
- Type		Electric	-
- Displacement	cm ³	2	-
- Power	kW	1.3	-
- Voltage	V	12	-
- Pressure 150 bars	A	-	-

DIMENSIONS			±
Working height = maximum height of the platform floor (H2) + 2,000 mm	mm	25890	1%
Working reach = max. reach (D1) + 500 mm	mm	19700	1%
Standard platform without gate and standard platform with gate (option)			
- External dimensions (length x width)	mm	2300 x 900	1%
- Floor dimensions (length x width)	mm	2240 x 840	1%
Narrow platform without gate (option)			
- External dimensions (length x width)	mm	1790 x 900	1%
- Floor dimensions (length x width)	mm	1730 x 840	1%
Angle of rotation of the platform to the left / to the right	°	90 / 90	1%
Upward and downward angle of deflection of the jib arm	°	70.3 / 63	1%
Turntable rotation angle	°	Continuous rotation	-
Other dimensions: DIMENSIONS AND AMPLITUDE OF MOVEMENT 260 TJ+.			

NOISE AND VIBRATION			±
Sound power level LwA	dB	102	-
Vibrations affecting body in the platform			
- Average quadratic values for the body	m/s ²	< 0.5	-

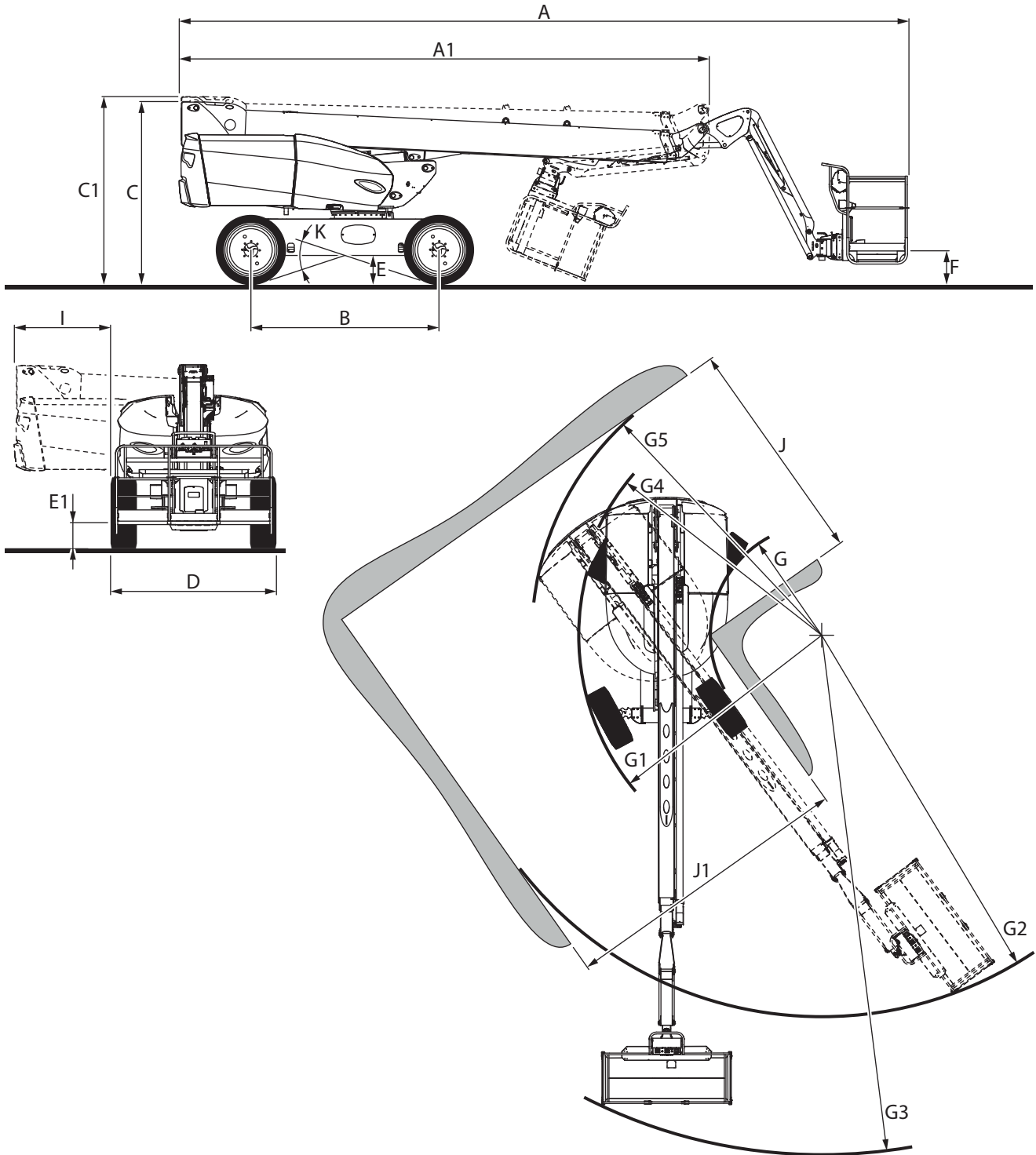

DIMENSIONS AND AMPLITUDE OF MOVEMENT 260 TJ+

A	mm	10840	E1	mm	355	G5	mm	5180
A1	mm	7880	F	mm	480	I	mm	1430
B	mm	2800	G	mm	1975	J	mm	4000
C	mm	2710	G1	mm	4355	J1	mm	5240
C1	mm	2800	G2	mm	6850	K	°/%	36 / 73
D	mm	2480	G3	mm	9280			
E	mm	415	G4	mm	4420			

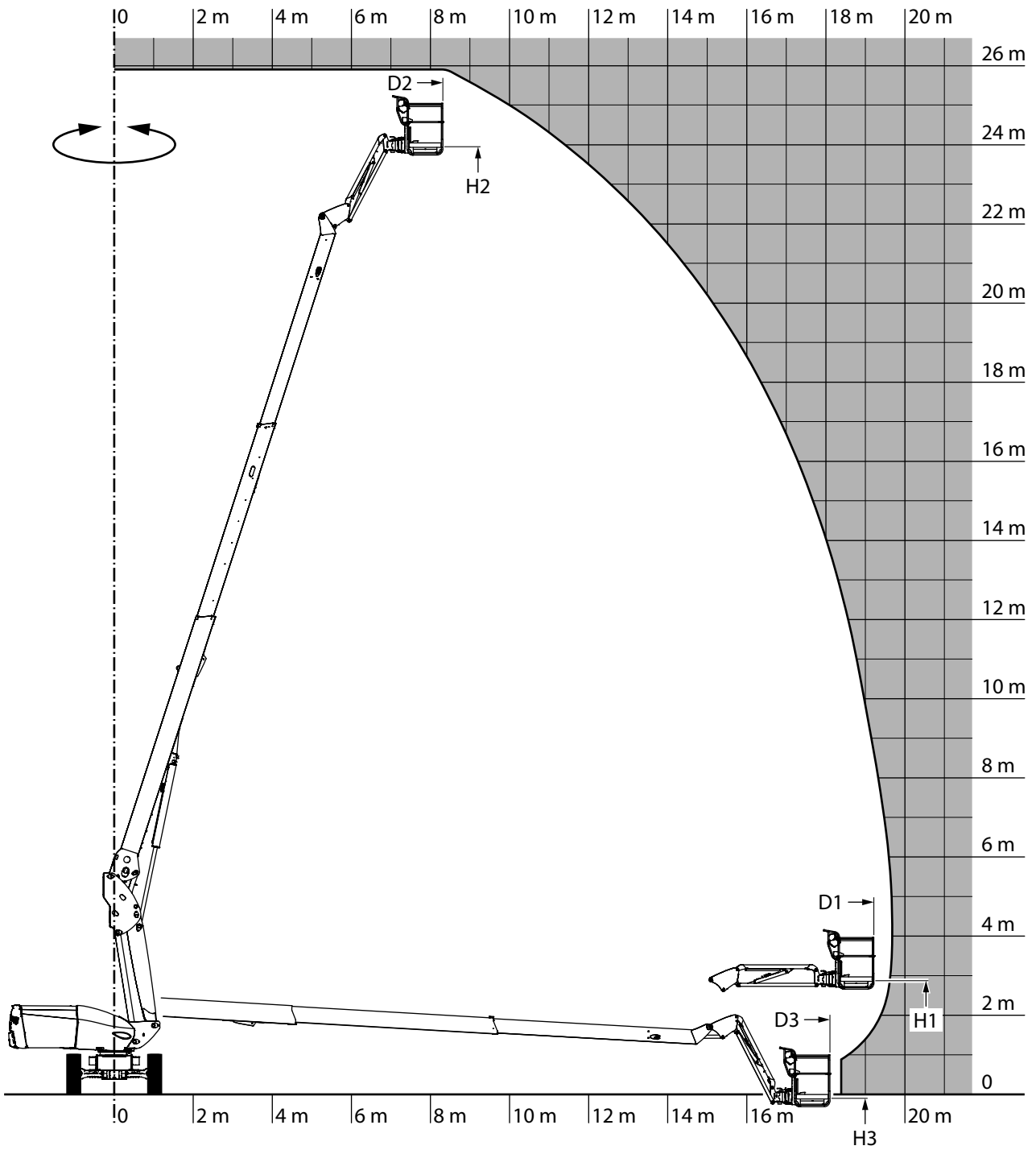

H1	mm	2785	H2	mm	23890	H3	mm	195
D1	mm	19200	D2	mm	8285	D3	mm	18095



GENERAL CHARACTERISTICS			±
Machine			
- Maximum load capacity the platform.	kg (lbs)	(1)	-
- Maximum wind speed when operating outside	km/h	45	-
- Maximum number of people in the platform (indoor use/ outdoor use)		(1)	-
- Machine weight, unladen	kg (lbs)	16500 (36377)	-
- Maximum authorized chassis tilt in working position	°	4	0.1%
- Maximum slope in transport position:			
1- Platform at the bottom of the slope with 100 kg (220 lbs) in the platform (maximum slope accessible)	 %	35	2
2- Platform at the top of the slope	 %	15	-
3- Lateral slope	 %	15	-
- Maximum manual force	N	400	-
Wheels			
- Load on one front wheel (transport position)	kg (lbs)	5600 (12350)	2%
- Load on one rear wheel (transport position)	kg (lbs)	3000 (6615)	2%
- Maximum load on one wheel (working position)	kg (lbs)	7780 (17148)	2%
- Bearing surface on ground (hard/soft)	cm ²	446 / 1125	5%
- Ground bearing pressure (hard/soft)	daN/cm ²	21.3 / 8.44	5%
(1) \triangleleft DIMENSIONS AND AMPLITUDE OF MOVEMENT 280 TJ.			

SPEEDS AND MOVEMENTS			±
Travel speeds			
- Working speed	km/h	0.8	0.1
- Reduced speed	km/h	1.8	-
- Slow speed	km/h	2.5	0.5
- Ramp speed	km/h	2.5	0.2
- Hare speed	km/h	4.5	0.2
Main arm (telescopic arm extended)			
- Lifting speed (unladen/laden)	s	70 / -	5
- Lowering speed (unladen/laden)	s	70 / -	5
Main arm (telescopic arm retracted)			
- Lifting speed (unladen/laden)	s	42 / -	5
- Lowering speed (unladen/laden)	s	42 / -	5
Telescopic arm			
- Extended (unladen/laden)	s	30 / -	5
- Retracted (unladen/laden)	s	30 / -	5
Pendulum arm (telescopic pendulum arm extended)			
- Lifting speed (unladen/laden)	s	30 / -	5
- Lowering speed (unladen/laden)	s	25 / -	5
Pendulum arm (telescopic pendulum arm retracted)			
- Lifting speed (unladen/laden)	s	22 / -	5
- Lowering speed (unladen/laden)	s	18 / -	5
Telescopic jib arm			
- Extended (unladen/laden)	s	16 / -	5
- Retracted (unladen/laden)	s	10 / -	5
Turntable			
- 90° rotation (telescopic arm extended/retracted/retracted and main arm raised)	s	50/30/28	5
Platform			
- Rotation to the right / to the left	s	7 / 7	2.5

DIESEL ENGINE			±
Type		YANMAR 4TNV88C	-
Fuel		Diesel	-
Number of cylinders		4	-
Displacement	cm ³	2190	-
Idling speed unladen	rpm	950	50
Maximum speed unladen	rpm	2800	50
Power at 2800 rpm	kW	34.3	-
Maximum torque at 1820 rpm	N.m	128	-
Unladen weight	kg (lbs)	205 (452)	5 (11)
Type of cooling		Coolant	-
Fan		Suction	-
Emissions			
- CO (carbon monoxide)	g/kWh	0.265	-
- CO2 (carbon dioxide)	g/kWh	838	-
- HC + Nox (hydrocarbons + nitrogen dioxide)	g/kWh	2.881	-
- PT (particles)	g/kWh	0.0068	-

TRANSMISSION			±
Hydrostatic pump			
- Type		BOSCH REXROTH	-
- Maximum cylinder capacity	cm ³	56	-
- Maximum unladen flow rate	L/min	168	-
- Maximum pressure	bar	400	-
Hydrostatic motor			
- Type		PARKER	-
- Displacement	cm ³	125	-
Axles			
- Type		DANA SPICER	-
- Reduction ratio		47.12	-
- Tractive force	daN	5850	-
- Front axle differential		45% limited slip	-
- Rear axle differential		100% hydraulic locking	-
Front / rear steering/directional wheels		2 / 2	-
Front / rear drive wheels		2 / 2	-
Wheels			
- Type		SOLIDEAL SOLIDAIR AWP	-
- Dimensions (external Ø x width)	mm	1025 x 365	-
- Inflation		Solid tire	-

BRAKES			±
Type		Negative	-
Type of order		Hydraulics	-
Front/rear braked wheels		2 / 2	-
Brake release (freewheeling)		Manual	-
Braking torque	daN.m	3100 on wheel	5%

HYDRAULIC CIRCUIT			±
Auxiliary hydraulic pump			
- Type		BOSCH REXROTH	-
- Maximum cylinder capacity	cm ³	28	-
- Maximum unladen flow rate	L/min	70	-
Control valve			
- Type		DANFOSS	-
- Maximum pressure	bar	240	5
Turntable rotation motor			
- Type		BONFIGLIOLI	-
- Reduction ratio		1: 24.5	-
Filtration			
- Suction	µm	125	-
- Pressure	µm	10	-
- Operation	µm	10	-

ELECTRIC CIRCUIT			±
Battery (original equipment)			
- Type		EXIDE	-
- Capacity C5	Ah	145	-
- Capacity C20	Ah	-	-
- Rated voltage	V	12	-
Alternator			
- Type		DENSO	-
- Maximum amperage	A	55	-
- Rated voltage	V	12	-
Starter			
- Type		HITACHI	-
- Power	kW	2.3	-
- Voltage	V	12	-

BACKUP PUMP			±
- Type		Electric	-
- Displacement	cm ³	2	-
- Power	kW	1.3	-
- Voltage	V	12	-
- Pressure 150 bars	A	-	-

DIMENSIONS			±
Working height = maximum height of the platform floor (H2) + 2,000 mm	mm	27735	1%
Working reach = max. reach (D1) + 500 mm	mm	21450	1%
Standard platform without gate and standard platform with gate (option)			
- External dimensions (length x width)	mm	2300 x 900	1%
- Floor dimensions (length x width)	mm	2240 x 840	1%
Narrow platform without gate (option)			
- External dimensions (length x width)	mm	1790 x 900	1%
- Floor dimensions (length x width)	mm	1730 x 840	1%
Angle of rotation of the platform to the left / to the right	°	90 / 90	1%
Upward and downward angle of deflection of the jib arm	°	56.8 / 62	1%
Turntable rotation angle	°	Continuous rotation	-
Other dimensions: DIMENSIONS AND AMPLITUDE OF MOVEMENT 280 TJ.			

NOISE AND VIBRATION			±
Sound power level LwA	dB	102	-
Vibrations affecting body in the platform			
- Average quadratic values for the body	m/s ²	< 0.5	-

DIMENSIONS AND AMPLITUDE OF MOVEMENT 280 TJ

A	mm	11355	E1	mm	355	G5	mm	5180
A1	mm	8095	F	mm	485	I	mm	1430
B	mm	2800	G	mm	1975	J	mm	4000
C	mm	2730	G1	mm	4355	J1	mm	5730
C1	mm	2710	G2	mm	7340	K	°/°	36 / 73
D	mm	2480	G3	mm	9750			
E	mm	415	G4	mm	4420			

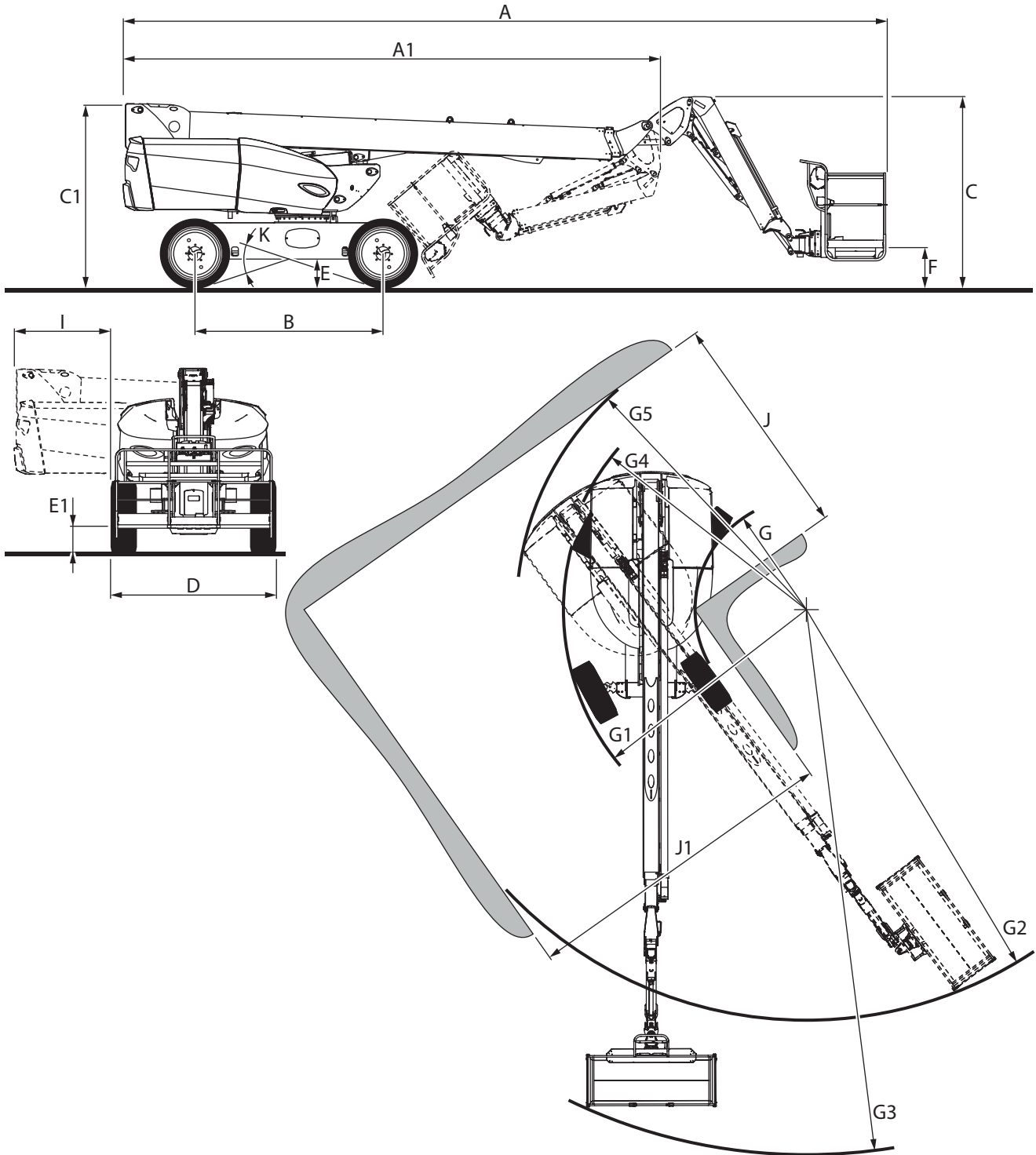

H1	mm	3035	H2	mm	25735	H3	mm	1165
D1	mm	20950	D2	mm	9100	D3	mm	19215

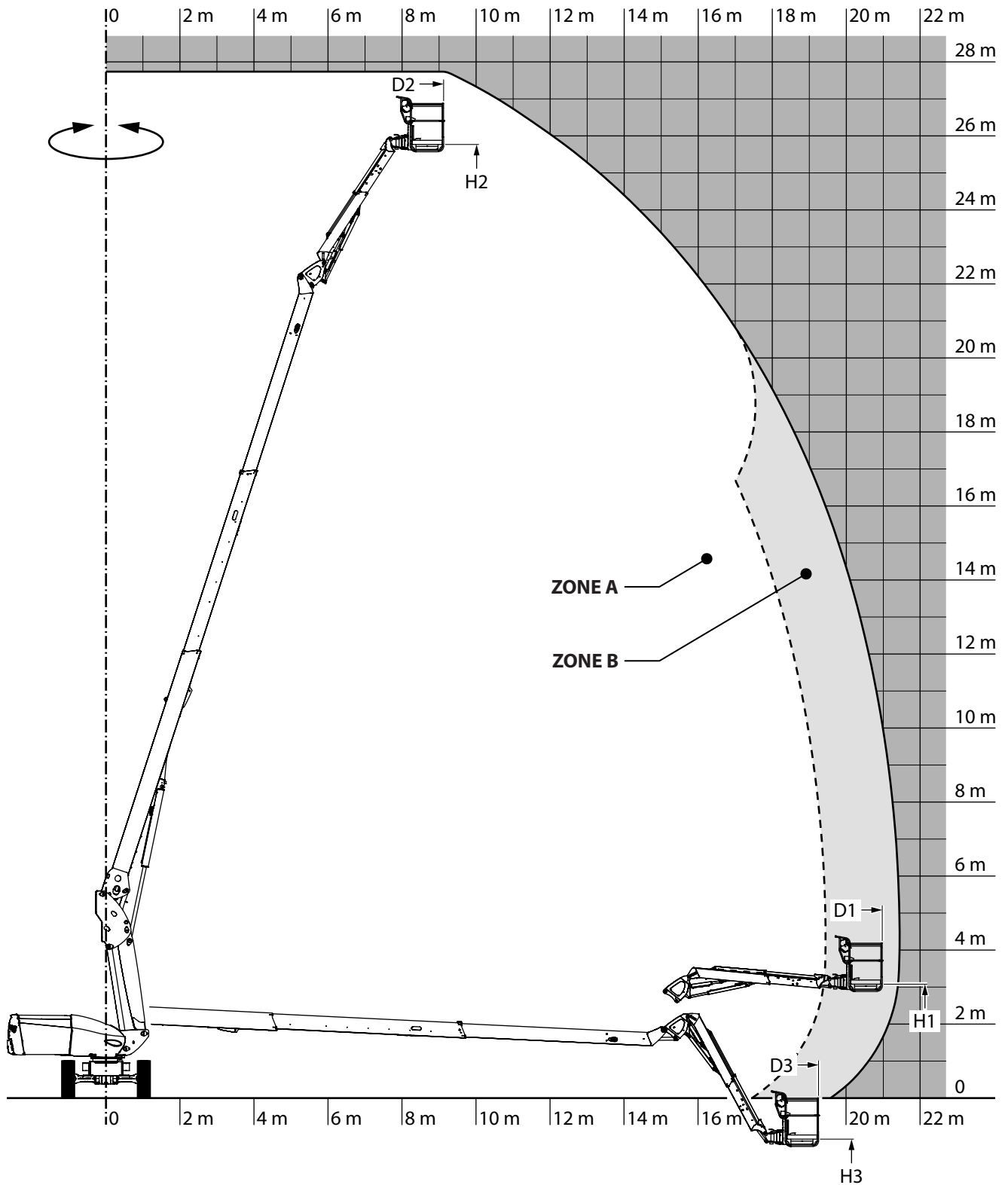

GENERAL CHARACTERISTICS		ZONE A	ZONE B	±
Machine				
- Maximum load capacity the platform.	kg (lbs)	350 (770) (1)	240 (530) (1)	-
- Maximum number of people in the platform (indoor use/ outdoor use)		3/3 (1)	2/2 (1)	-
(1) Pipe support attachment or panel support attachment not installed, ≤ 4 - ATTACHMENTS for the specific values when an attachment is installed.				

SAFETY COMPONENTS

SLIDING MID RAILS

Standard platform without gate.

⚠ IMPORTANT ⚠

*Do not attach the sliding mid rails in the high position.
Make sure that the sliding mid rails are in the low position before using the machine.*

The platform has 3 sliding mid rails ①.

- Lift up one of the sliding mid rails to get into and out of the platform.

Note: the illustration shows a 260 TJ+ platform.



SLIDING MID RAILS AND GATE

Standard platform with gate (option).

⚠ IMPORTANT ⚠

*Do not attach the sliding mid rails in the high position.
Make sure that the sliding mid rails are in the low position before using the machine.
Make sure that the gate is properly closed before using the machine.*

The platform has 2 sliding mid rails ① and a gate ② with a locking handle.

- Lift up one of the sliding mid rails to get into and out of the platform.
- or

- Get into or out of the platform through the gate.

Note: the illustration shows a 260 TJ+ platform.



SLIDING MID RAIL

Narrow platform without gate (option).

⚠ IMPORTANT ⚠

*Do not attach the sliding mid rail in the high position.
Make sure that the sliding mid rail is in the low position before using the machine.*

The platform has a sliding mid rail ①.

- Lift up the sliding mid rail to get into and out of the platform.

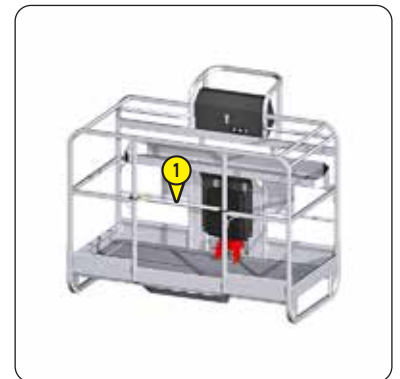

SAFETY HARNESS ATTACHMENT POINTS

⚠ IMPORTANT ⚠

Only one operator/occupant is permitted to use each attachment point.

- Attach the safety harnesses to the attachment points ① in the platform.

Note: 4 attachment points, ⚠ STICKERS: SAFETY HARNESS ATTACHMENT POINTS.

Note: the illustration shows a 260 TJ+ standard platform without gate.

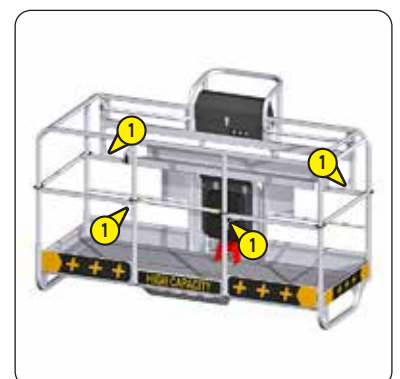

HANDRAILS

⚠ IMPORTANT ⚠

- When using the machine:*
- Do not hold onto the platform guardrails.
 - Hold onto the handrails ①.

Note: the illustration shows a 260 TJ+ standard platform without gate. The standard platform with gate (option) does not have a handrail on the gate side.



TURNTABLE LOCKING PIN

Locking the turntable prevents it from rotating.

Position ①: the turntable is unlocked.

Position ②: the turntable is locked.

LOCK THE TURNTABLE

- Align the locking pin ① and the chassis notch ②.
- Move and push the locking pin into the chassis notch (position ②).

UNLOCK THE TURNTABLE

- Pull the locking pin ① out of the chassis notch ②.
- Move the locking pin to the position ①.

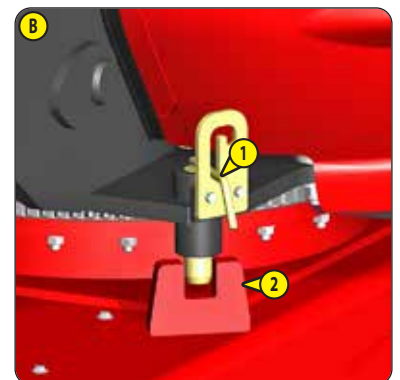

Note: the illustration ③ shows a machine with the battery cut-off option.



CONTROL PANEL AND SAFETY DEVICES AT GROUND LEVEL

⚠ IMPORTANT ⚠

This machine is equipped with an integrated tilting sensor in the ground level control panel (➔ 1 - INSTRUCTIONS AND SAFETY INSTRUCTIONS: MACHINE MAINTENANCE INSTRUCTIONS).

Left and right are defined in OPERATING THE MACHINE: TRANSPORT/WORKING POSITION.

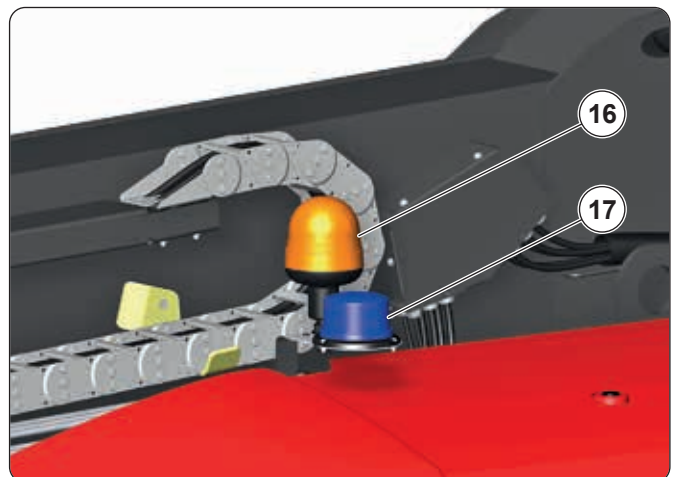
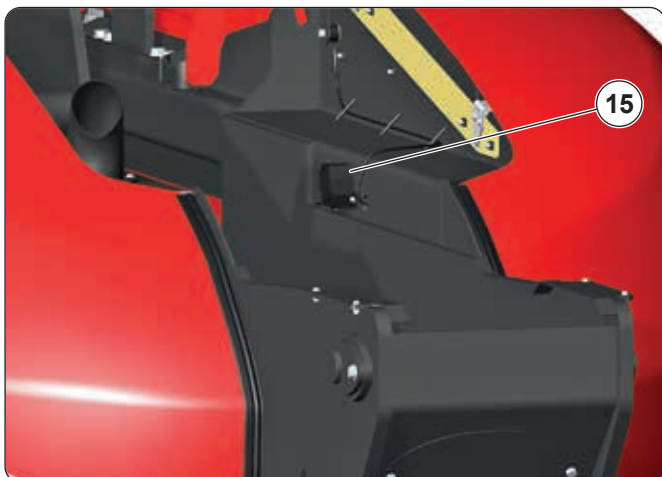
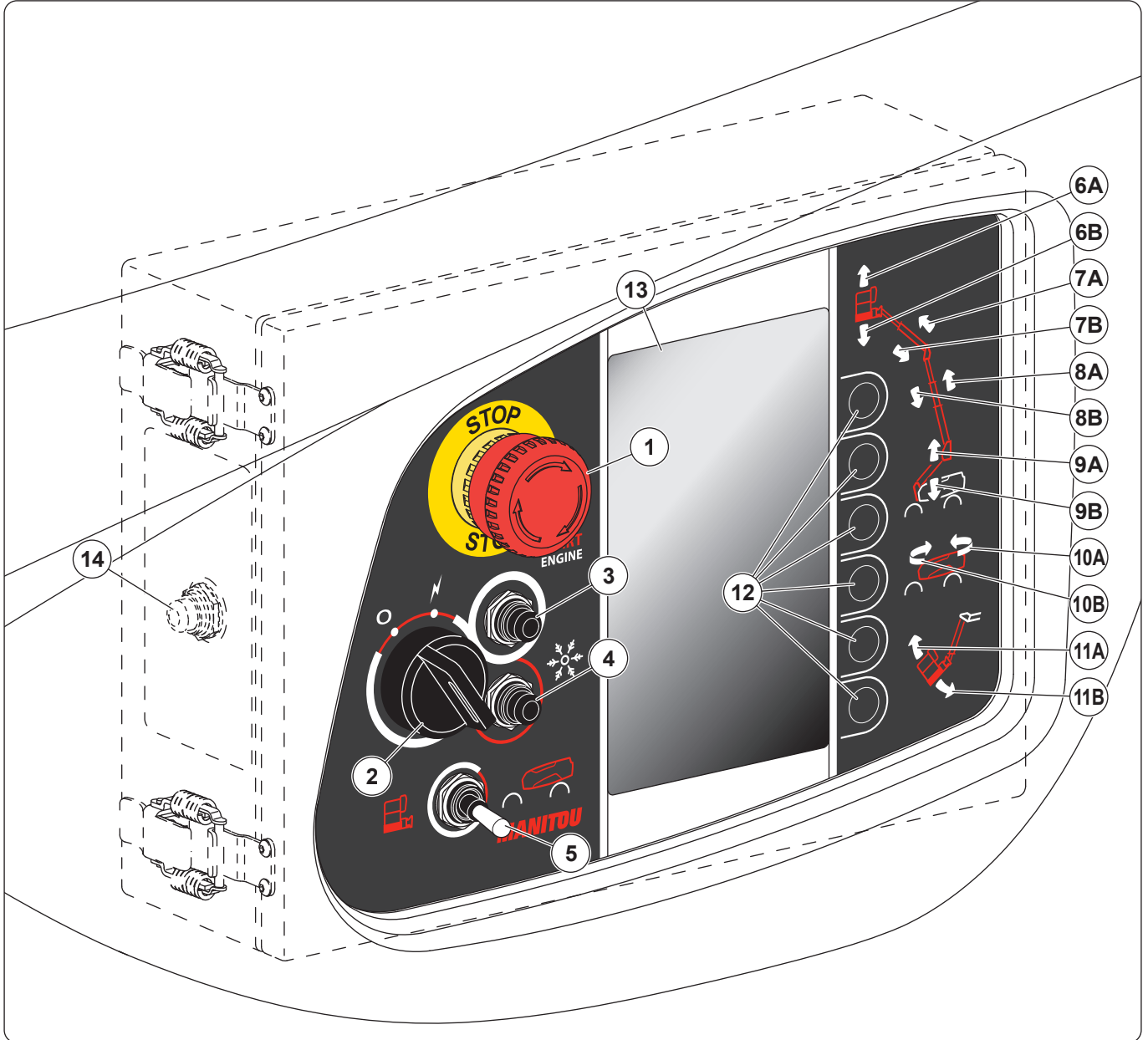

1- EMERGENCY STOP BUTTON	2-51
2- KEY SWITCH	2-51
3- START BUTTON	2-51
4- START MODE BUTTON	2-51
5- ACTIVATION SWITCH	2-52
6- JIB ARM CONTROL BUTTONS	2-52
7- TELESCOPIC JIB ARM CONTROL BUTTONS ONLY FOR 280 TJ	2-52
8- TELESCOPIC ARM CONTROL BUTTONS	2-52
9- MAIN ARM CONTROL BUTTONS	2-53
10- TURNTABLE ROTATION CONTROL BUTTONS	2-53
11- PLATFORM/JIB ARM TILT CONTROL BUTTONS	2-53
12- NAVIGATION KEYS	2-53
13- GROUND-LEVEL DISPLAY SCREEN	2-53
14- BACKUP PUMP BUTTON	2-54
15- HORN	2-54
16- ORANGE ROTATING BEACON LIGHT	2-54
17- FLASHING LIGHT SPS (OPTION)	2-54

CONTROL PANEL AND SAFETY DEVICES IN THE PLATFORM

⚠ IMPORTANT ⚠

Front, rear, left and right are defined in OPERATING THE MACHINE: TRANSPORT/WORKING POSITION.

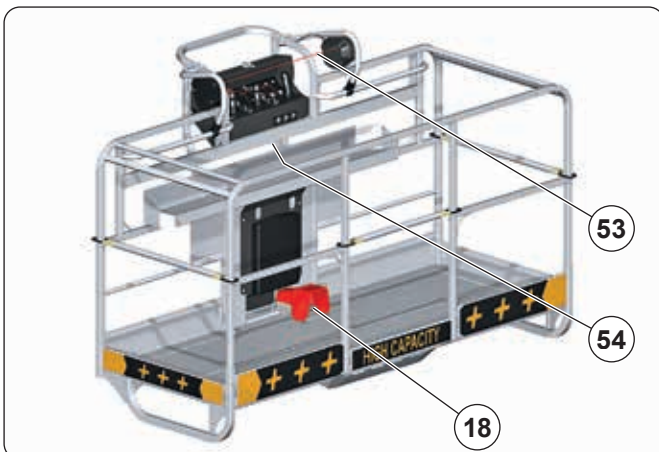
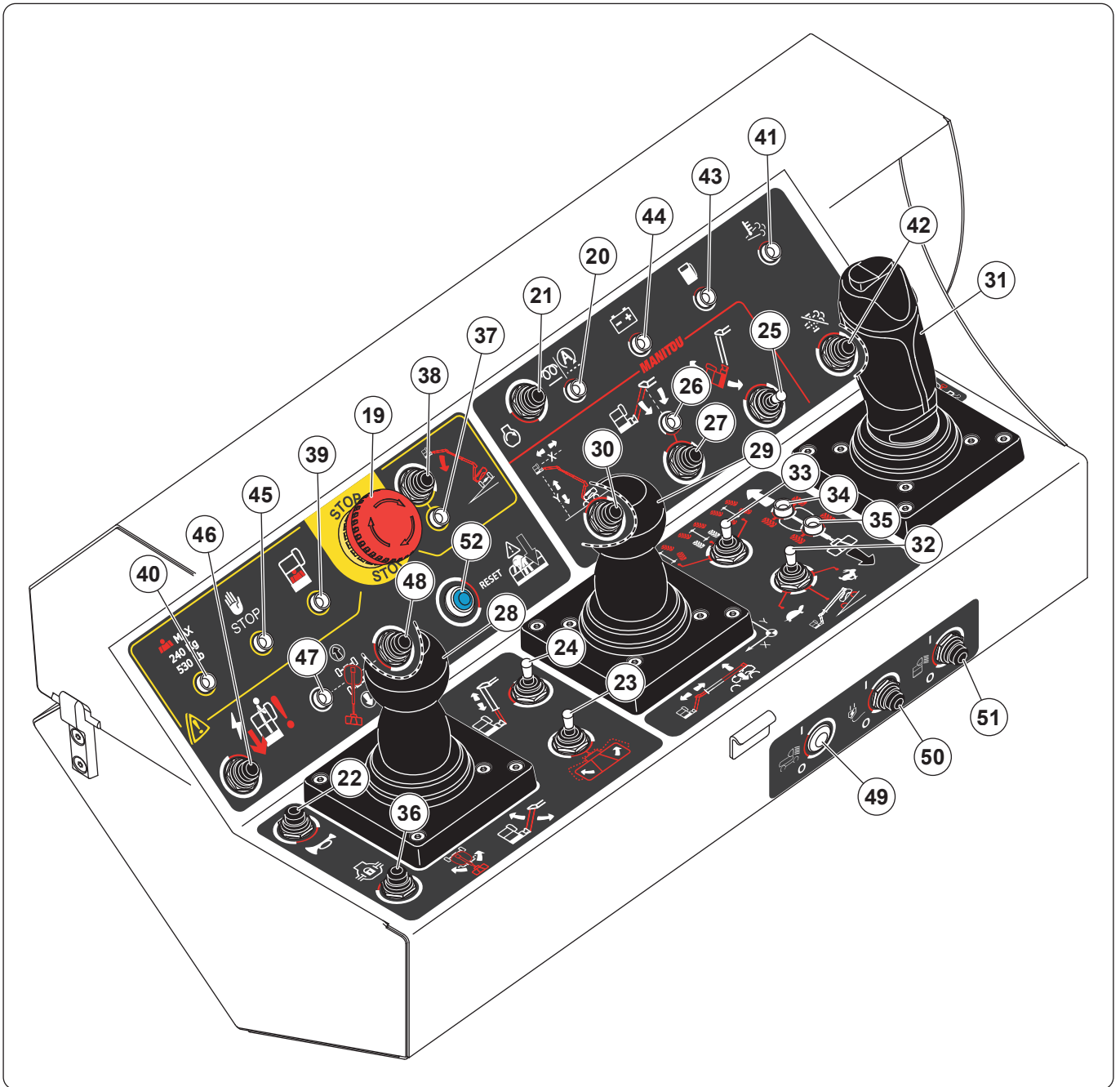

Note: the illustration shows a 260 TJ+ standard platform without gate.

18- FOOT SWITCH	2-55
19- EMERGENCY STOP BUTTON	2-55
20- PREHEAT INDICATOR LIGHT	2-55
21- START BUTTON.....	2-55
22- HORN BUTTON	2-56
23- PLATFORM ROTATION SWITCH	2-56
24- TELESCOPIC JIB ARM SWITCH ONLY FOR 280 TJ	2-56
25- PLATFORM TILT SWITCH ONLY FOR 280 TJ	2-56
26- PLATFORM/JIB ARM TILT INDICATOR LIGHT.....	2-57
27- PLATFORM/JIB ARM TILT BUTTON.....	2-57
28- JIB ARM/TURNABLE ROTATION CONTROL HANDLE.....	2-58
29- MAIN ARM/TELESCOPIC ARM CONTROL HANDLE	2-58
30- X/Y FUNCTION BUTTON	2-59
31- DRIVING/STEERING CONTROL HANDLE	2-60
32- DRIVING SPEED SWITCH	2-60
33- STEERING MODE SWITCH	2-61
34- FRONT WHEEL ALIGNMENT INDICATOR LIGHT	2-61
35- REAR WHEEL ALIGNMENT INDICATOR LIGHT	2-61
36- DIFFERENTIAL LOCK BUTTON	2-61
37- OSCILLATION TILT/LOCK INDICATOR LIGHT	2-62
38- USE ON SLOPE BUTTON	2-62
39- OVERLOAD INDICATOR LIGHT	2-63
40- RESTRICTED CAPACITY INDICATOR LIGHT ONLY FOR 280 TJ	2-63
41- EXHAUST REGENERATION INDICATOR LIGHT	2-64
42- EXHAUST REGENERATION BUTTON	2-64
43- FUEL INDICATOR LIGHT	2-64
44- BATTERY INDICATOR LIGHT	2-65
45- FAULT INDICATOR LIGHT	2-65
46- BACKUP PUMP BUTTON.....	2-66
47- TURNTABLE SLEWING INDICATOR LIGHT	2-67
48- TURNTABLE SLEWING BUTTON	2-67
49- NOT USED.....	2-67
50- ELECTRIC GENERATOR BUTTON (OPTION)	2-67
51- WORKLIGHT BUTTON (OPTION).....	2-67
52- RESET BUTTON SPS (OPTION)	2-67
53- SAFETY CABLE SPS (OPTION).....	2-68
54- HORN.....	2-68

REMOTE CONTROL UNIT

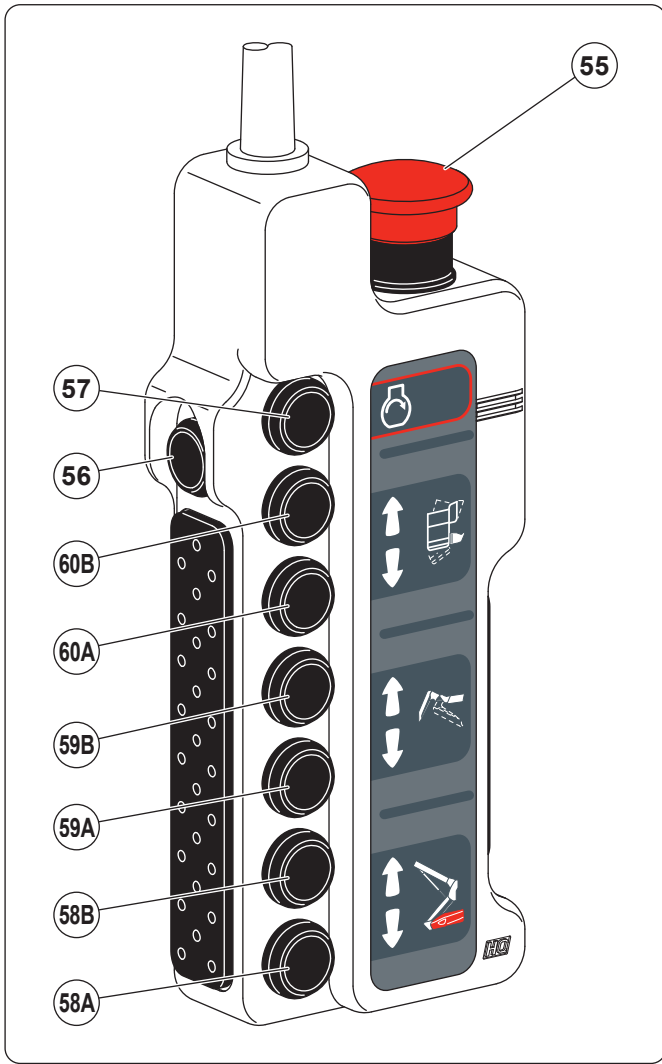

55- EMERGENCY STOP BUTTON	2-69
56- ACTIVATION BUTTON	2-69
57- START BUTTON.....	2-69
58- MAIN ARM BUTTONS	2-69
59- PLATFORM/JIB ARM TILT BUTTONS	2-70
60- PLATFORM TILT BUTTONS ONLY FOR 280 TJ	2-70

1- EMERGENCY STOP BUTTON

⚠ IMPORTANT ⚠

*In all cases this control takes priority, even if the machine functions are activated from the platform control panel.
Movements may stop suddenly if the emergency stop button is pressed.*

2 positions:

- Off (locked): press and hold the button.
- On (unlocked): pull the button or turn it clockwise and release.

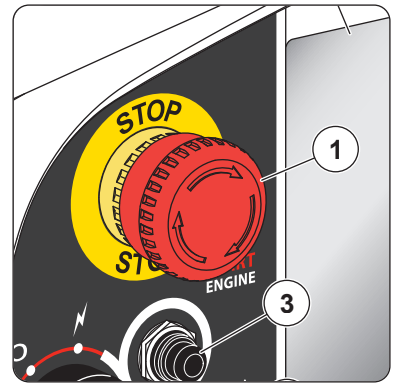

2- KEY SWITCH

2 positions:



Stop: the control system is turned off. The key can be removed.

Note: the battery cut-off (option) must be in the off position to turn off the machine.



On: the control system is turned on. The key cannot be removed.

Note: the battery cut-off (option) must be in the on position and the 2 emergency stop buttons must be in the on position to start up the machine.

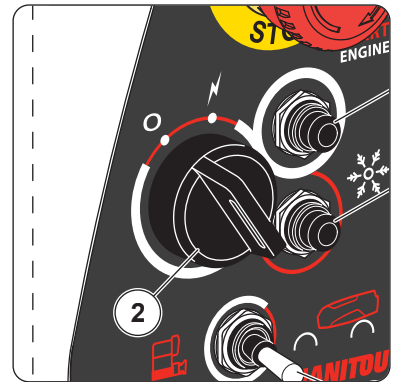

3- START BUTTON

⚠ IMPORTANT ⚠

Do not keep the button pressed for more than 15 seconds.

- Wait for the preheat cycle to finish.
- Press and hold down the button to start the diesel engine.
- Release it once the diesel engine has started.

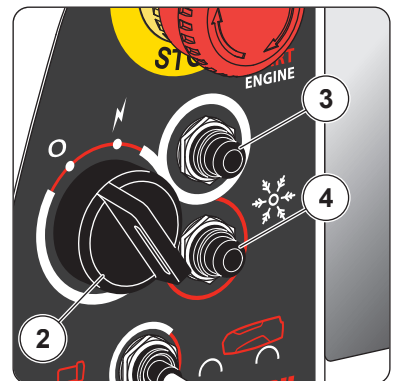

4- START MODE BUTTON

2 positions:

- Sun position if outside temperature above -10 °C:
 - Activated by default.
- Snow position if outside temperature below -10 °C:
 - Press the button and release.
 - Press and hold the start button to start the diesel engine: it runs at high speed.
 - Release it once the diesel engine has started.
 - Wait for between 30 and 60 seconds without using the machine's functions.
 - Press the button and release or use a machine function to switch to sun position: the diesel engine runs at idle speed.

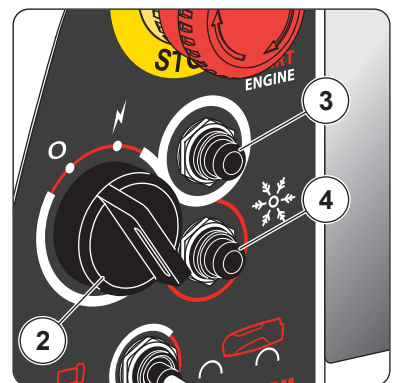

5- ACTIVATION SWITCH

2 positions:



Platform controls: the platform controls are activated when the switch is released.



Ground level controls: push and hold the switch to the right to activate the ground level controls.

Note: this operating mode is called the "dead man" function.

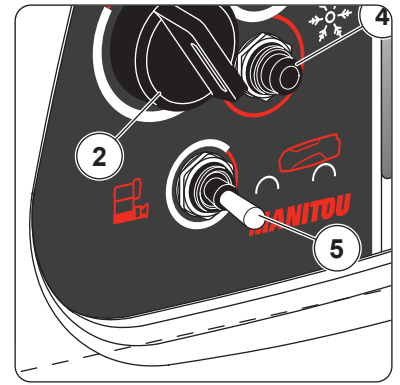

6- JIB ARM CONTROL BUTTONS

- Push and hold the activation switch to the right  (ground level controls position).

RAISE THE JIB ARM

- Press and hold down the button . Release to stop.

LOWER THE JIB ARM

- Press and hold down the button . Release to stop.

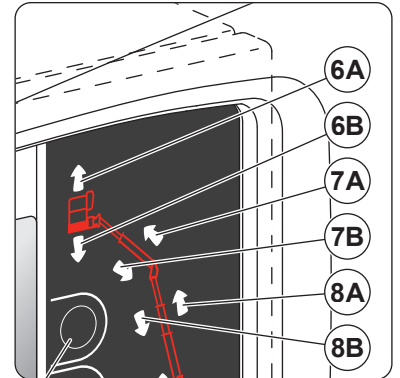

7- TELESCOPIC JIB ARM CONTROL BUTTONS ONLY FOR 280 TJ

- Push and hold the activation switch to the right  (ground level controls position).

EXTEND THE TELESCOPIC JIB ARM

- Press and hold down the button . Release to stop.

RETRACT THE TELESCOPIC JIB ARM

- Press and hold down the button . Release to stop.

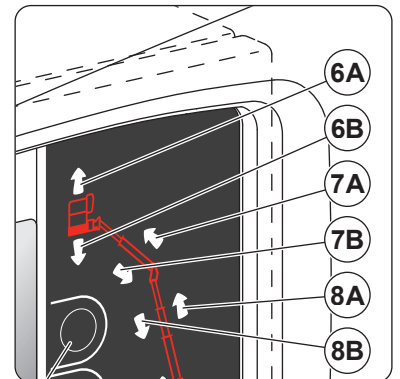

8- TELESCOPIC ARM CONTROL BUTTONS

- Push and hold the activation switch to the right  (ground level controls position).

EXTEND THE TELESCOPIC ARM

- Press and hold down the button . Release to stop.

RETRACT THE TELESCOPIC ARM

- Press and hold down the button . Release to stop.

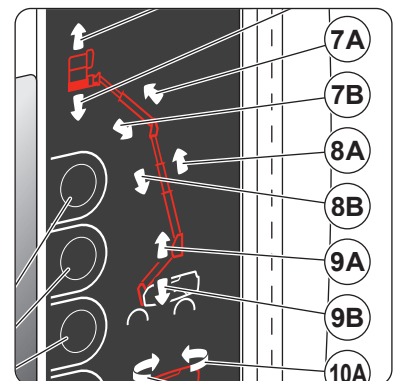

9- MAIN ARM CONTROL BUTTONS

- Push and hold the activation switch to the right  (ground level controls position).

RAISE THE MAIN ARM

- Press and hold down the button . Release to stop.

LOWER THE MAIN ARM

- Press and hold down the button . Release to stop.

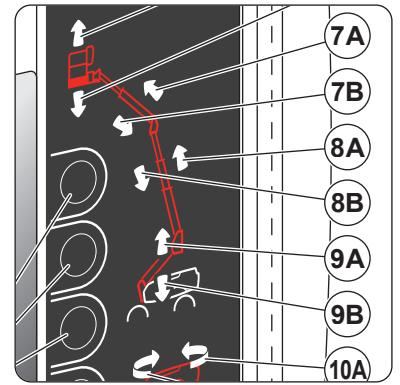

10- TURNTABLE ROTATION CONTROL BUTTONS

- Push and hold the activation switch to the right  (ground level controls position).

TURN THE TURNTABLE TO THE RIGHT

- Press and hold down the button . Release to stop.

TURN THE TURNTABLE TO THE LEFT

- Press and hold down the button . Release to stop.

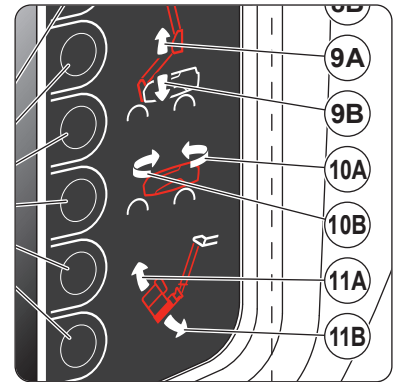

11- PLATFORM/JIB ARM TILT CONTROL BUTTONS

- Push and hold the activation switch to the right  (ground level controls position).

TILT THE PLATFORM/JIB ARM UP

- Press and hold down the button . Release to stop.

TILT THE PLATFORM/JIB ARM DOWN

- Press and hold down the button . Release to stop.

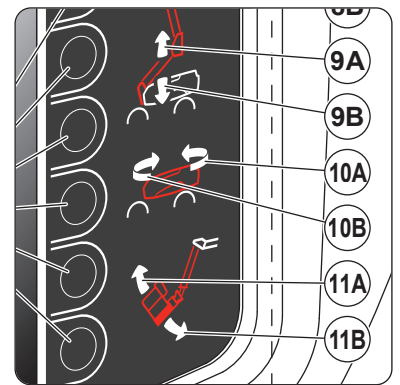

12- NAVIGATION KEYS

- ◀ GROUND-LEVEL DISPLAY SCREEN.

13- GROUND-LEVEL DISPLAY SCREEN

- ◀ GROUND-LEVEL DISPLAY SCREEN.

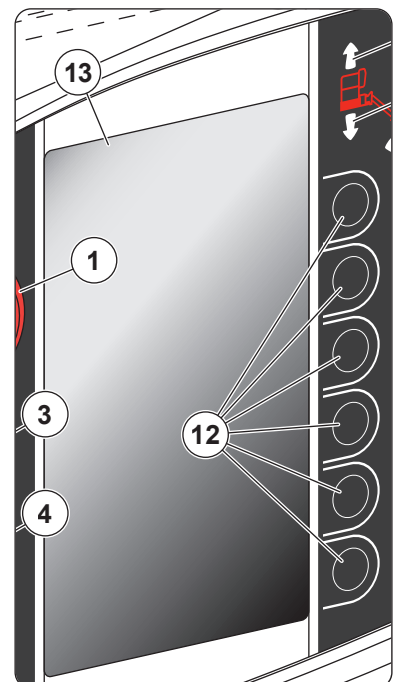

14- BACKUP PUMP BUTTON

◀ EMERGENCY CONTROLS.

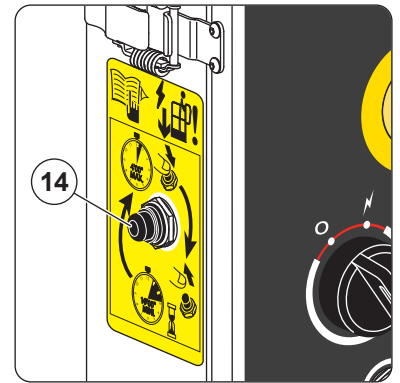

15- HORN

The horn sounds:

- When the horn button is pressed.
- Twice when the diesel engine has been started without activating the machine's functions for 10 seconds, ▶ GROUND LEVEL DISPLAY SCREEN: ALERT PAGE AND FAULT PAGE.

All movements alarm option: it sounds intermittently when the machine functions are activated and when driving/steering the machine.

Driving/steering alarm option: it sounds intermittently when driving/steering the machine.

Secondary protection system option SPS, ▶ OPTIONS: SECONDARY PROTECTION SYSTEM SPS.



16- ORANGE ROTATING BEACON LIGHT

Permanent orange rotating beacon light option deactivated: it comes on when the machine functions are activated and when driving/steering the machine.

Permanent orange rotating beacon light activated: it comes on when the machine is powered up.

Note: there is a specific operating mode with the diesel engine automatic stop system "stop and go", ▶ OPERATING THE MACHINE: DIESEL ENGINE AUTOMATIC STOP SYSTEM "STOP AND GO".

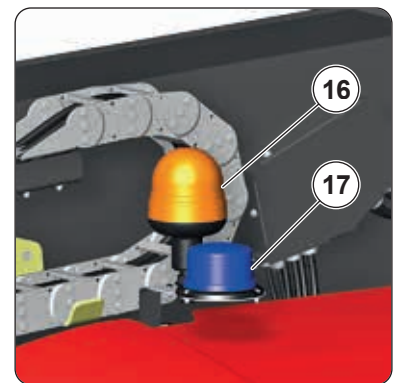

17- FLASHING LIGHT SPS (OPTION)

▶ OPTIONS: SECONDARY PROTECTION SYSTEM SPS.

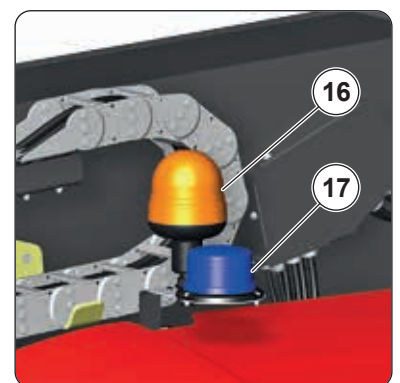

18- FOOT SWITCH

⚠ IMPORTANT ⚠

Do not press the foot switch when starting the diesel engine.

Note: the illustration shows a 260 TJ+ standard platform without gate.

- Press and hold down the foot switch to activate the machine functions from the platform control panel.

Note: this operating mode is called the "dead man" function.

Note: there is a specific operating mode with the diesel engine automatic stop system "stop and go", OPERATING THE MACHINE: DIESEL ENGINE AUTOMATIC STOP SYSTEM "STOP AND GO".

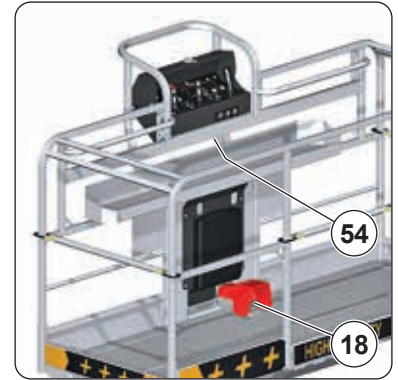

19- EMERGENCY STOP BUTTON

⚠ IMPORTANT ⚠

In all cases, this control takes priority, except when the machine functions are activated from the ground level control panel.

Movements may stop suddenly if the emergency stop button is pressed.

2 positions:

- Off (locked): press and hold the button.
- On (unlocked): pull the button or turn it clockwise and release.

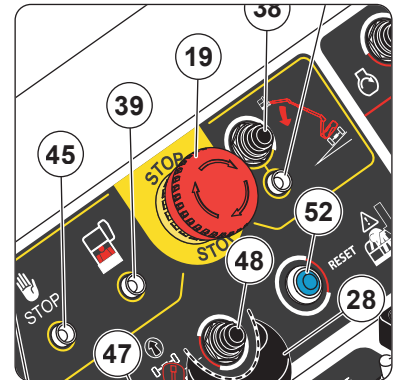

20- PREHEAT INDICATOR LIGHT

The indicator light is lit during the diesel engine preheat cycle.

It switches off when the preheat cycle is completed.

It flashes when the diesel engine is stopped by the diesel engine automatic stop system "stop and go", OPERATING THE MACHINE: DIESEL ENGINE AUTOMATIC STOP SYSTEM "STOP AND GO".

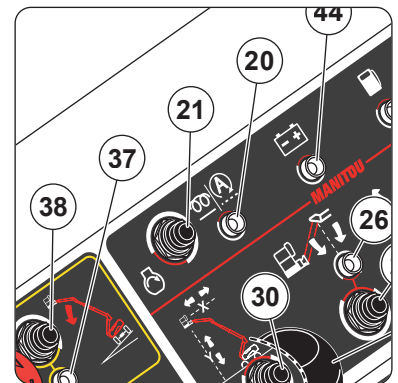

21- START BUTTON

⚠ IMPORTANT ⚠

Do not keep the button pressed for more than 15 seconds.

- Wait for the preheat cycle to finish.
- Press and hold down the button to start the diesel engine.
- Release it once the diesel engine has started.

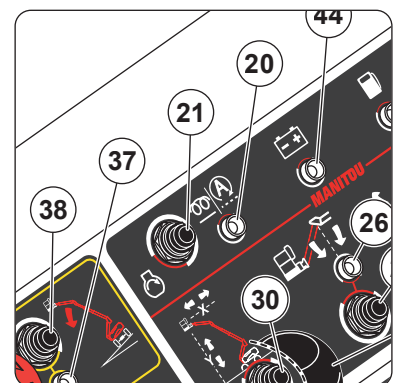

22- HORN BUTTON

- Press and hold down the button to sound the horn. Release to stop.

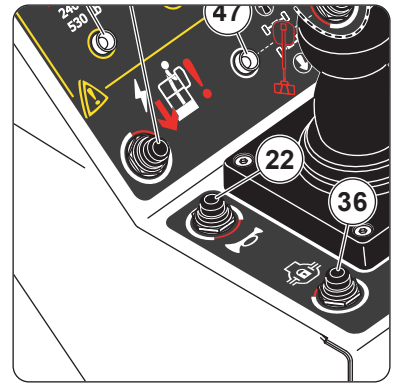

23- PLATFORM ROTATION SWITCH

- Press and hold down the foot switch.

TURN THE PLATFORM TO THE LEFT

- Push and hold the switch to the left. Release to stop.

TURN THE PLATFORM TO THE RIGHT

- Push and hold the switch to the right. Release to stop.

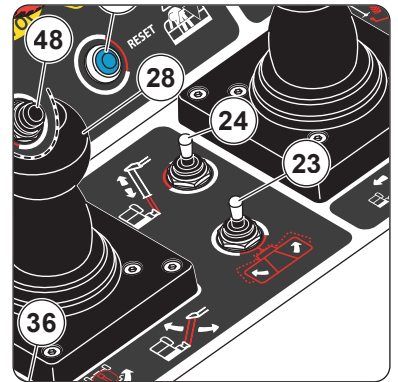

24- TELESCOPIC JIB ARM SWITCH ONLY FOR 280 TJ

- Press and hold down the foot switch.

EXTEND THE TELESCOPIC JIB ARM

- Push and hold the switch forward. Release to stop.

RETRACT THE TELESCOPIC JIB ARM

- Pull and hold the switch backward. Release to stop.

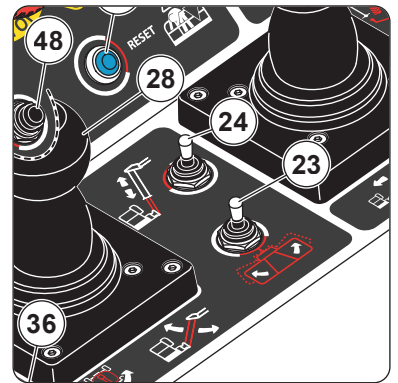

25- PLATFORM TILT SWITCH ONLY FOR 280 TJ

Note: the functions are locked when the machine is in working position, OPERATING THE MACHINE: TRANSPORT/WORKING POSITION.

- Press and hold down the foot switch.

TILT THE PLATFORM UP

- Push and hold the switch upward. Release to stop.

TILT THE PLATFORM DOWN

- Push and hold the switch downward. Release to stop.

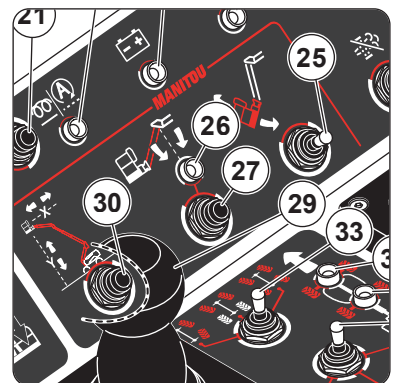

26- PLATFORM/JIB ARM TILT INDICATOR LIGHT

◀ PLATFORM/JIB ARM TILT BUTTON 27.

27- PLATFORM/JIB ARM TILT BUTTON

⚠ IMPORTANT ⚠

◀ **FAULT INDICATOR LIGHT** when the indicator light 26 flashes at the same time as the **FAULT INDICATOR LIGHT**.

The platform/jib arm tilt is given by the position of the gage A in relation to the sticker B PLATFORM/JIB ARM TILT.

The indicator light 26 is off when the platform/jib arm tilt is less than 5° (up or down).

PLATFORM/JIB ARM TILT WARNING

The indicator light 26 is on when the platform/jib arm tilt is greater than 5° and less than 9° (up or down). It is necessary to reset the platform/jib arm tilt to zero:

- Press and hold down the foot switch.
- Press and hold down the button.
- Wait until the indicator light goes off and then wait until the audible alarm sounds once.
- Release the button.

Note: ▶ sticker C PLATFORM/JIB ARM TILT RESET.

The indicator light 26 flashes when the platform/jib arm tilt is greater than 9° (up or down):

Note: the audible alarm sounds intermittently and all the machine's functions are locked.

- Alert somebody on the ground so that they can use the emergency controls to exit the platform.
- If necessary, consult maintenance personnel to unlock the machine's functions.

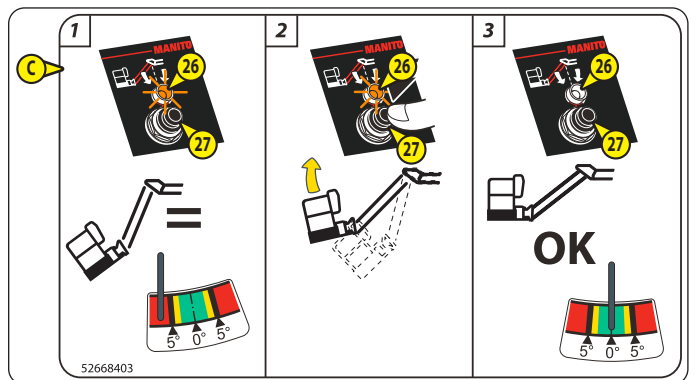
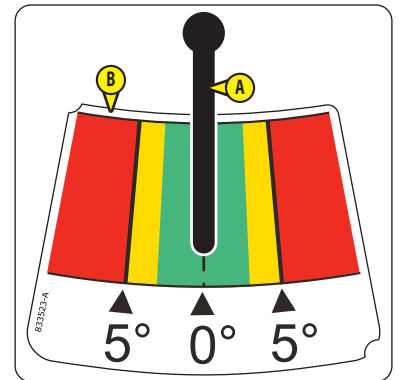
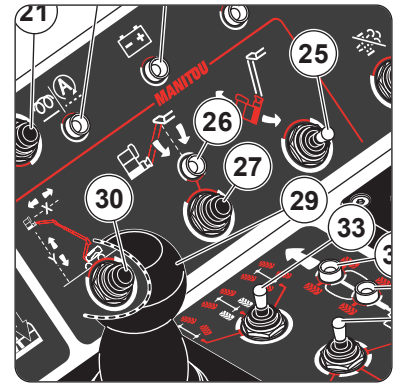

28- JIB ARM/TURNTABLE ROTATION CONTROL HANDLE

Note: the proportional control handle must be operated smoothly, without jerking.

- Press and hold down the foot switch.

RAISE THE JIB ARM

- Push and hold the control handle forward. Release to stop.

LOWER THE JIB ARM

- Pull and hold the control handle back. Release to stop.

TURN THE TURNTABLE TO THE LEFT

- Push and hold the control handle to the left. Release to stop.

TURN THE TURNTABLE TO THE RIGHT

- Push and hold the control handle to the right. Release to stop.

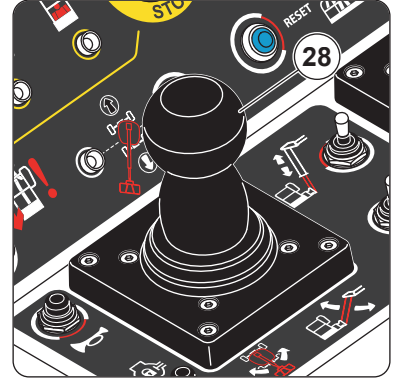

29- MAIN ARM/TELESCOPIC ARM CONTROL HANDLE

Note: the proportional control handle must be operated smoothly, without jerking.

- Press and hold down the foot switch.

RAISE THE MAIN ARM

- Push and hold the control handle forward. Release to stop.

LOWER THE MAIN ARM

- Pull and hold the control handle back. Release to stop.

EXTEND THE TELESCOPIC ARM

- Push and hold the control handle to the left. Release to stop.

RETRACT THE TELESCOPIC ARM

- Push and hold the control handle to the right. Release to stop.

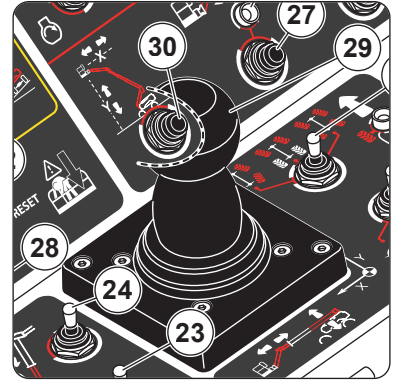

30- X/Y FUNCTION BUTTON

Note: the audible alarm sounds intermittently when the button is pressed.

- Press and hold down the foot switch.
- Press and hold down the button.

X FUNCTION

Use this function to maintain a constant distance between the platform and a horizontal surface (e.g. a ceiling) when extending or retracting the telescopic arm.

- Push and hold down the control handle (29) to the left or right. Release to stop.
- Release the button.

Note: sticker (A) X-Y FUNCTION.

FUNCTION Y

Use this function to maintain a constant distance between the platform and a surface (e.g. a wall) when raising or lowering the main arm.

- Push and hold down the control handle (29) up or down. Release to stop.
- Release the button.

Note: sticker (A) X-Y FUNCTION.

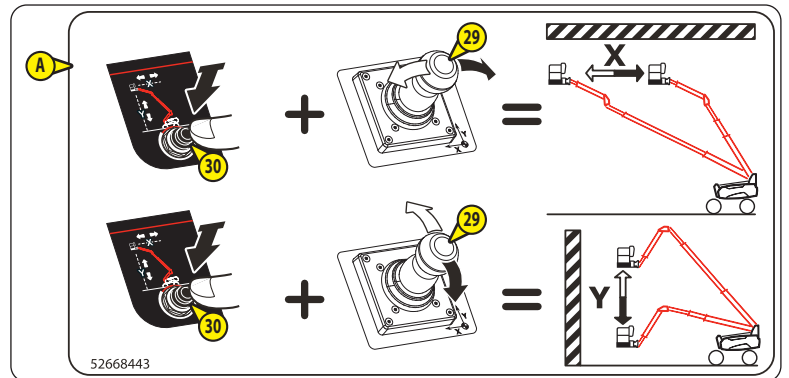
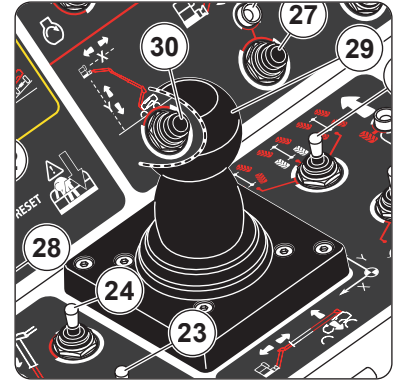

31- DRIVING/STEERING CONTROL HANDLE

⚠ IMPORTANT ⚠

Always refer to the colors of the arrows on the chassis and on the control panel in the platform before driving/steering the machine.

Note: the proportional control handle must be operated smoothly, without jerking.

- Press and hold down the foot switch.
- Press and hold down the trigger **A**.

DRIVE FORWARD

- Push and hold the control handle forward. Release to brake.

DRIVE BACKWARD

- Pull and hold the control handle back. Release to brake.

BRAKE

- Release the control handle in neutral position to action the brakes.

Note: the brakes are also engaged when the foot switch and/or the trigger are released.

STEER TO THE LEFT

- Press and hold down button **B**. Release to stop.

STEER TO THE RIGHT

- Press and hold down button **C**. Release to stop.

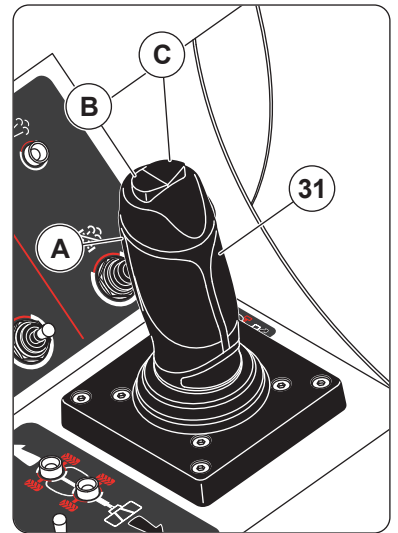
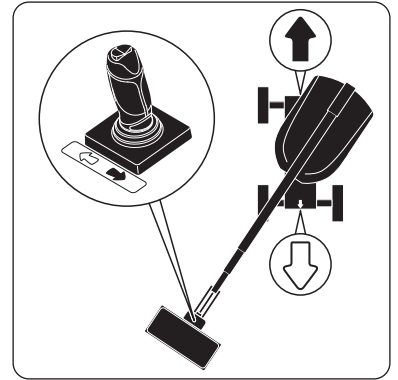

32- DRIVING SPEED SWITCH

⚠ IMPORTANT ⚠

Always brake the machine before selecting the driving speed.

3 positions:

 Tortoise speed for driving the machine at slow speed.

 Ramp speed for driving the machine at slow speed with full power.

 Hare speed for driving the machine at high speed.

Note: depending on conditions, restrictions may apply to the speed activated,

⚠ OPERATING THE MACHINE: TRANSPORT/WORKING POSITION.

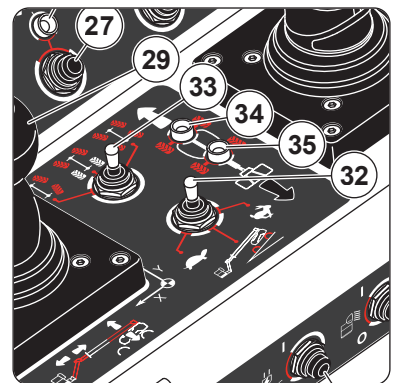

33- STEERING MODE SWITCH

⚠ IMPORTANT ⚠

Always brake the machine before changing the steering mode.

The front and rear wheels must be correctly aligned with the machine axis before changing the steering mode,

◀ FRONT WHEEL ALIGNMENT INDICATOR LIGHT and ▶ REAR WHEEL ALIGNMENT INDICATOR LIGHT.

If the wheels are not correctly aligned:

- Select the 4 wheel steer mode and align the rear wheels.*
- Select the 2 wheel steer mode and align the front wheels.*

3 positions:



4 wheel steer mode: front and rear steering wheels in opposite directions.



2 wheel steer mode: front steering wheels.



Crab mode: front and rear steering wheels in the same direction.

Note: depending on conditions, restrictions may apply to the speed activated,

◀ OPERATING THE MACHINE: TRANSPORT/WORKING POSITION.

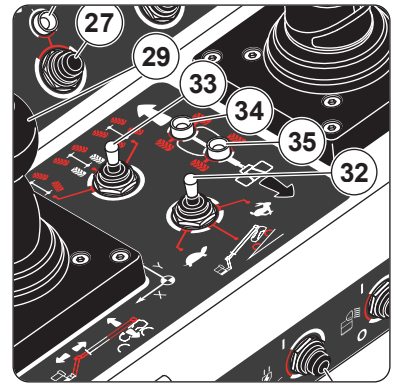

34- FRONT WHEEL ALIGNMENT INDICATOR LIGHT

The indicator light comes on when the front wheels are correctly aligned with the machine axis.

35- REAR WHEEL ALIGNMENT INDICATOR LIGHT

The indicator light comes on when the rear wheels are correctly aligned with the machine axis.

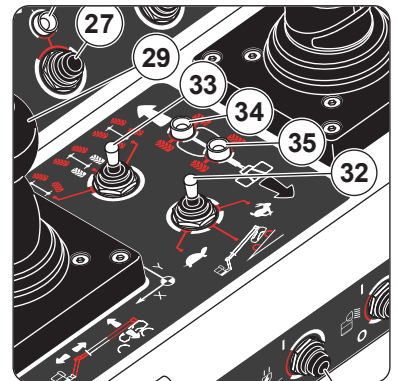

36- DIFFERENTIAL LOCK BUTTON

⚠ IMPORTANT ⚠

It is recommended to align the wheels with the machine axis before locking and unlocking the differential.

LOCK THE DIFFERENTIAL

- Drive the machine, then press and hold down the button.
- or
- Press and hold down the button to drive the machine.

UNLOCK THE DIFFERENTIAL

- Release the button, then brake the machine.
- or
- Brake the machine, then release the button.

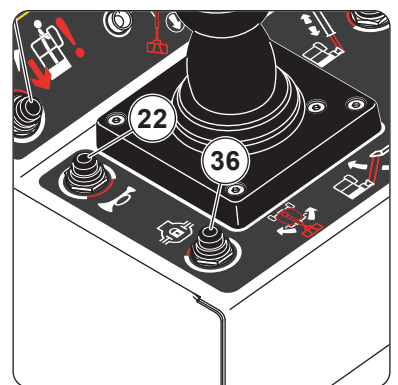

37- OSCILLATION TILT/LOCK INDICATOR LIGHT

TILT WARNING

It occurs when the tilt of the chassis is greater than the maximum authorized value:

- The indicator light flashes (on = 0.6 seconds, off = 0.4 seconds).
- The audible alarm sounds intermittently (on = 1 second, off = 1 second).
- Some machine functions are locked, OPERATING THE MACHINE: LOCKED FUNCTIONS.

Stop the tilt warning and unlock the machine functions (machine in transport position):

- Move the machine to a level surface.

Stop the tilt warning and unlock the machine functions (machine in work position):

- 1- Fully retract the telescopic arm.
- 2- Retract the telescopic jib arm completely (only for 280 TJ).
- 3- Fully lower the main arm.
- 4- Move the machine to a level surface.

OSCILLATION LOCK FAULT

It occurs when an oscillating axle locking fault occurs (machine in working position):

- The indicator light flashes (on = 0.4 seconds, off = 0.2 seconds).
- The fault indicator light flashes, FAULT INDICATOR LIGHT.
- The audible alarm sounds intermittently (on = 0.4 second, off = 0.4 second).
- Some machine functions are locked, OPERATING THE MACHINE: LOCKED FUNCTIONS.

React in the event of an oscillation lock fault:

- 1- Fully retract the telescopic arm.
- 2- Retract the telescopic jib arm completely (only for 280 TJ).
- 3- Fully lower the main arm.
- 4- Fully lower the jib arm.
- 5- Move the machine to a level surface.
- 6- Stop using the machine and refer to the maintenance personnel.

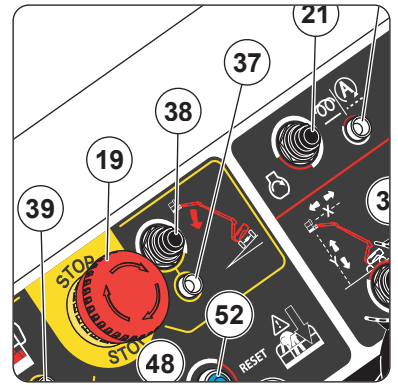

38- USE ON SLOPE BUTTON

⚠ IMPORTANT ⚠

The machine could tip over when this function is used. Use with extreme caution.

- Press the button and hold it down to activate the locked functions (except driving forward and backward) when the tilt alarm is activated. OSCILLATION TILT/LOCK INDICATOR LIGHT.

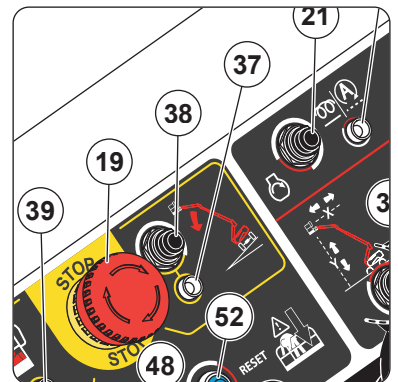

39- OVERLOAD INDICATOR LIGHT

OVERLOAD WARNING

It occurs when the platform load has reached maximum load capacity:

- The indicator light flashes.
- The audible alarm sounds continuously.
- All the machine's functions are locked,  OPERATING THE MACHINE: LOCKED FUNCTIONS.

Stop the overload warning and unlock the machine functions:

- Remove the excess load from the platform.

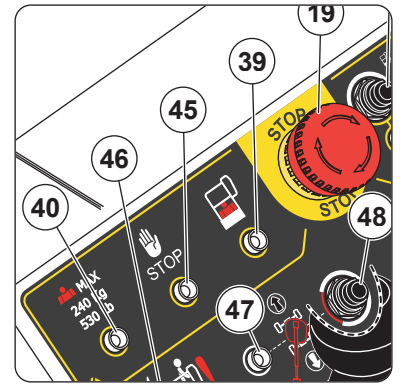

40- RESTRICTED CAPACITY INDICATOR LIGHT ONLY FOR 280 TJ

The status of the indicator light depends on the zone where the platform is located and the load in the platform.

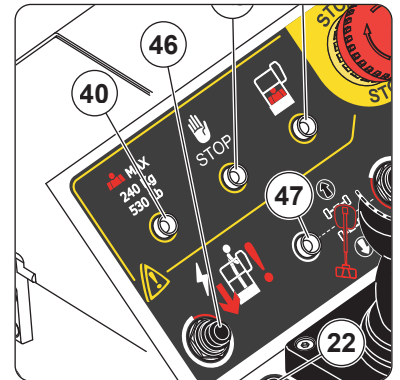

	LOAD IN THE PLATFORM	INDICATOR LIGHT	
ZONE A (RESTRICTED CAPACITY)	Less than 240 kg (530 lbs.)	Unlit	It is possible to reach ZONE B.
	More than 240 kg (530 lbs.)	Lit	It is not possible to reach ZONE B: lowering of the main arm is locked or extension of the telescopic arm is locked.
ZONE B (RESTRICTED CAPACITY)	Less than 240 kg (530 lbs.)	Flashing	The load in the platform is limited to 240 kg (530 lbs).
	More than 240 kg (530 lbs.)	Lit	The load in the platform has reached maximum capacity in the zone. The overload indicator light flashes and the audible alarm sounds continuously (overload warning).

Note:  DIMENSIONS AND AMPLITUDE OF MOVEMENT 280 TJ for the definition of zones.

41- EXHAUST REGENERATION INDICATOR LIGHT

◀ OPERATING THE MACHINE: AUTOMATIC EXHAUST REGENERATION and ▶ OPERATING THE MACHINE: "STATIONARY MACHINE" EXHAUST REGENERATION.

42- EXHAUST REGENERATION BUTTON

◀ OPERATING THE MACHINE: AUTOMATIC EXHAUST REGENERATION and ▶ OPERATING THE MACHINE: "STATIONARY MACHINE" EXHAUST REGENERATION.

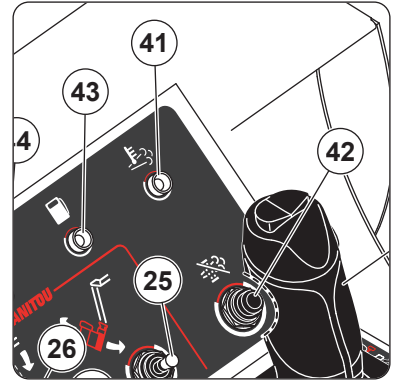

43- FUEL INDICATOR LIGHT

LOW FUEL LEVEL FAULT

It occurs when the fuel level is low.

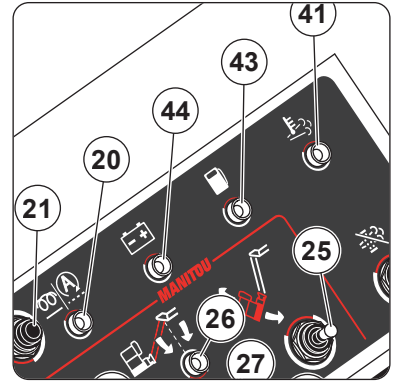

	INDICATOR LIGHT	HORN
Level 1	On = 0.8 seconds Off = 0.4 seconds	3 beeps (ON = 0.6 seconds, OFF = 0.4 seconds) repeated every 10 minutes
Level 2	On = 0.4 seconds Off = 0.4 seconds	3 beeps (ON = 0.4 seconds, OFF = 0.4 seconds) repeated every minute
Level 3 (1)	On = 0.3 seconds Off = 0.2 seconds	3 beeps (ON = 0.4 seconds, OFF = 0.4 seconds) repeated every 10 seconds

(1) The fault indicator light flashes at the same time.

(1) It is no longer possible to raise the main arm, extend the telescopic arm, raise the jib arm, tilt the platform/jib arm up, tilt the platform/jib arm down, extend the telescopic jib arm (280 TJ), tilt the platform up/down (280 TJ), turn the turntable or turn the platform for more than 5 seconds at a time.

44- BATTERY INDICATOR LIGHT

LOW BATTERY FAULT

It occurs when the diesel engine is automatically stopped by the diesel engine automatic stop system "stop and go" and the battery voltage is low:

- The indicator light flashes.
- The audible alarm sounds intermittently.

React in the event of a low battery fault:

- It is recommended to restart the diesel engine.

Note: ⚠ OPERATING THE MACHINE: DIESEL ENGINE AUTOMATIC STOP SYSTEM "STOP AND GO".

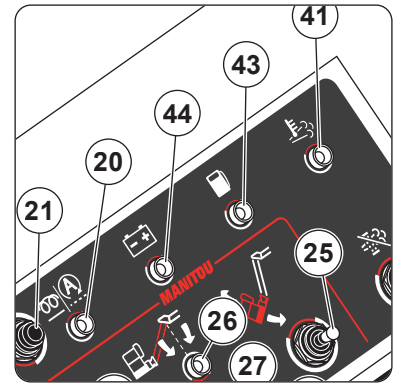

45- FAULT INDICATOR LIGHT

⚠ IMPORTANT ⚠

Refer to the maintenance personnel if there is a fault.

The fault indicator light flashes when a fault occurs:

- Minor fault except (1): on = 0.6 seconds, off = 0.4 seconds.
- Major fault: on = 0.3 seconds, off = 0.2 seconds.

(1) The indicator light is on when "stationary machine" exhaust regeneration is required.

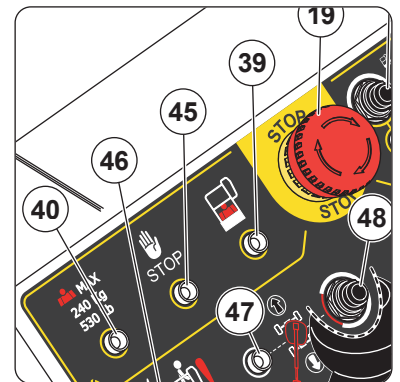

MINOR FAULTS	HORN	
The activation switch or foot switch is blocked	1 beep	Stop using the machine.
The activation button is blocked		
The driving/steering control handle trigger is locked		
The reset button SPS or the safety cable SPS is blocked (option: secondary protection system SPS)	3 beeps repeated every 8 seconds	
"Stationary machine" exhaust regeneration is required (1)	Sounds intermittently	⚠ OPERATING THE MACHINE: EXHAUST REGENERATION.
Other minor faults	Stop	Stop using the machine.

47- TURNTABLE SLEWING INDICATOR LIGHT

◀ TURNTABLE SLEWING BUTTON 48.

48- TURNTABLE SLEWING BUTTON

⚠ IMPORTANT ⚠

Always refer to the colors of the arrows on the chassis and on the control panel in the platform before driving/steering the machine.

TURNTABLE SLEWING ALARM

It occurs when the turntable angle is greater than 90° (left or right) in relation to the neutral position:

- The indicator light 47 comes on.
- The driving/steering functions are locked.

Note: the audible alarm sounds twice when trying to drive.

Unlock the driving/steering functions:

- Press the button and release.

Result:

- The indicator light flashes.

Note: the turntable slewing alarm will occur again if the driving/steering control handle is not actioned in the next 5 seconds.

Stop the turntable slewing alarm and unlock the driving/steering functions:

- Turn the turntable until the turntable angle is less than 90° (left or right) in relation to the neutral position.

Result:

- The indicator light goes out.

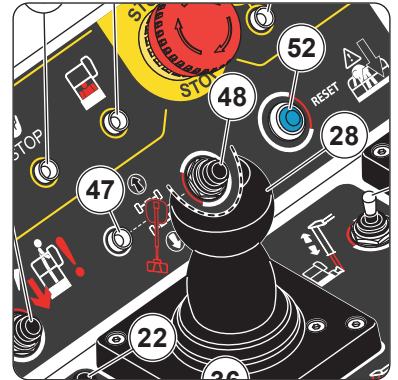
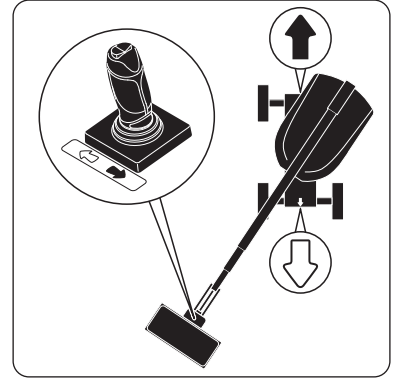

49- NOT USED

50- ELECTRIC GENERATOR BUTTON (OPTION)

◀ OPTIONS: ELECTRIC GENERATOR.

51- WORKLIGHT BUTTON (OPTION)

◀ OPTIONS: WORKLIGHT IN THE PLATFORM

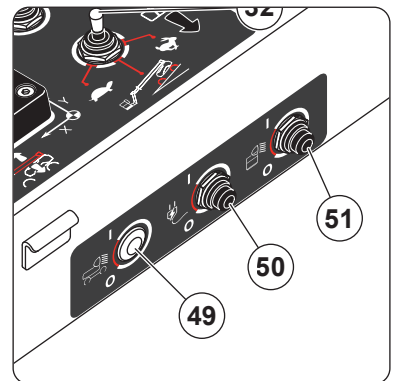

52- RESET BUTTON SPS (OPTION)

◀ OPTIONS: SECONDARY PROTECTION SYSTEM SPS.

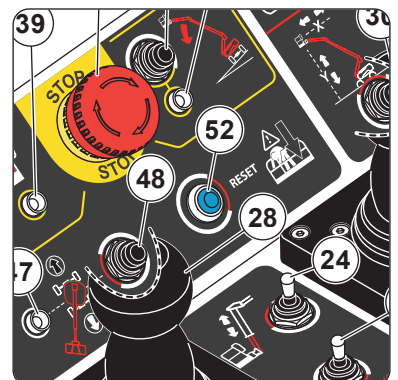

53- SAFETY CABLE SPS (OPTION)

Note: the illustration shows a 260 TJ+ standard platform without gate.

☞ OPTIONS: SECONDARY PROTECTION SYSTEM SPS.

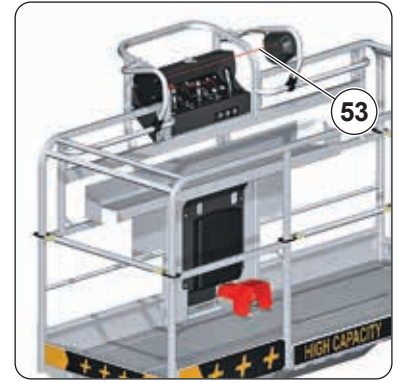

54- HORN

Note: the illustration shows a 260 TJ+ standard platform without gate.

The audible alarm sounds:

- Once after the machine has been powered up.
- Twice when the machine's functions cannot be activated simultaneously, ☞ OPERATING THE MACHINE.

PLATFORM/JIB ARM TILT WARNING

- It sounds intermittently when the platform/jib arm tilt is greater than 9° (up or down), ☞ PLATFORM/JIB ARM TILT BUTTON

X/Y FUNCTION

- It sounds intermittently when using the X function or the Y function, ☞ X/Y FUNCTION BUTTON.

TILT WARNING

- It sounds intermittently when the tilt of the chassis is greater than the maximum authorized value, ☞ OSCILLATION TILT/LOCK INDICATOR LIGHT.

OSCILLATION LOCK FAULT

- Intermittently when an oscillating axle locking fault occurs, ☞ OSCILLATION TILT/LOCK INDICATOR LIGHT.

OVERLOAD WARNING

- It sounds continuously when the platform load has reached maximum load capacity, ☞ OVERLOAD INDICATOR LIGHT.

LOW FUEL LEVEL FAULT

- It sounds when the fuel level is low, ☞ FUEL INDICATOR LIGHT.

LOW BATTERY FAULT

- It sounds intermittently when the battery voltage is low, ☞ BATTERY INDICATOR LIGHT.

OTHER FAULTS

- It sounds when a minor or major fault occurs, ☞ FAULT INDICATOR LIGHT.

TURNTABLE SLEWING ALARM

- It sounds twice when you try to drive, ☞ TURNTABLE SLEWING BUTTON.

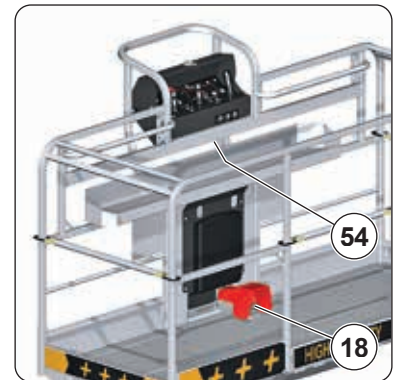

55- EMERGENCY STOP BUTTON

⚠ IMPORTANT ⚠

In all cases, this control takes priority, except when the machine functions are activated from the ground level control panel.

Movements may stop suddenly if the emergency stop button is pressed.

2 positions:

- Off (locked): press and hold the button.
- On (unlocked): pull the button or turn it clockwise and release.

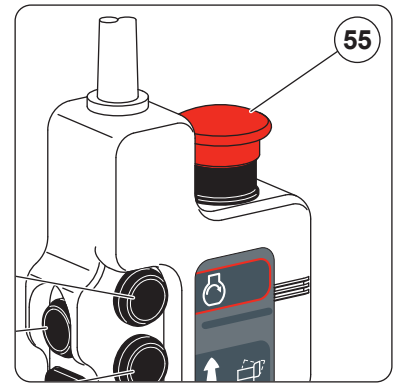

56- ACTIVATION BUTTON

- Press and hold down the button to activate the machine functions from the remote control unit.

Note: this operating mode is called the "dead man" function.

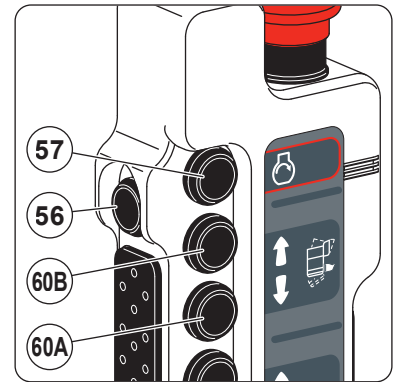

57- START BUTTON

⚠ IMPORTANT ⚠

Do not keep the button pressed for more than 15 seconds.

- Wait for the preheat cycle to finish.
- Press and hold down the activation button.
- Press and hold down the start button to start the diesel engine.
- Release the start button once the diesel engine has been started.
- Release the activation button.

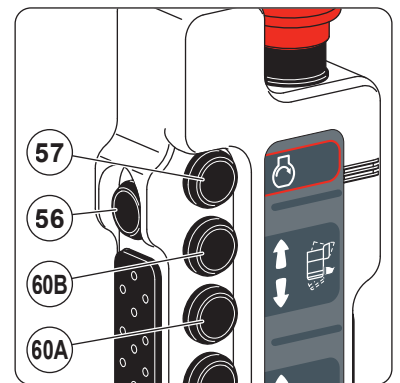

58- MAIN ARM BUTTONS

- Press and hold down the activation button.

RAISE THE MAIN ARM

- Press and hold down button **58B**. Release to stop.

LOWER THE MAIN ARM

- Press and hold down button **58A**. Release to stop.

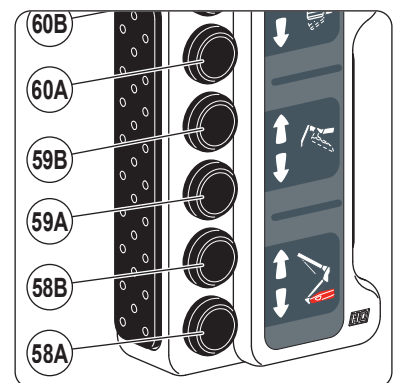

59- PLATFORM/JIB ARM TILT BUTTONS

- Press and hold down the activation button.

TILT THE PLATFORM/JIB ARM UP

- Press and hold down button **59B**. Release to stop.

TILT THE PLATFORM/JIB ARM DOWN

- Press and hold down button **59A**. Release to stop.

Note: these functions can only be activated when the angle of the main arm is 15° maximum in relation to the fully lowered position.

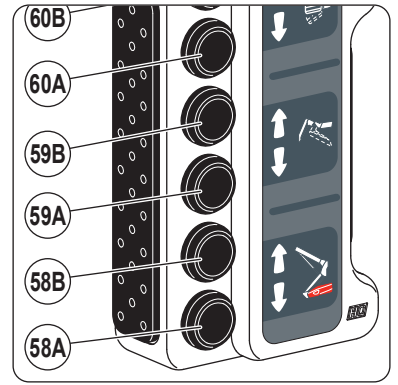

60- PLATFORM TILT BUTTONS ONLY FOR 280 TJ

- Press and hold down the activation button.

TILT THE PLATFORM UP

- Press and hold down button **60B**. Release to stop.

TILT THE PLATFORM DOWN

- Press and hold down button **60A**. Release to stop.

Note: these functions can only be activated when the platform/jib arm tilt is less than 5° (up or down), refer to the position of the gage **A** in relation to the sticker **B** PLATFORM/JIB ARM TILT.

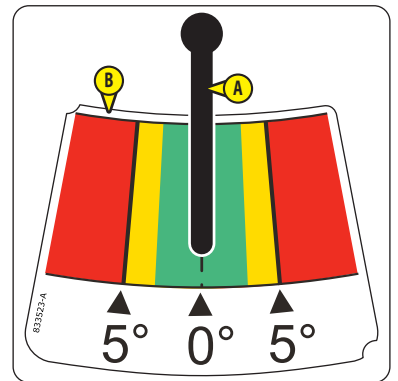
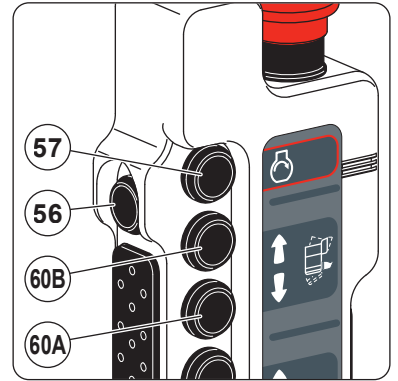

GROUND LEVEL DISPLAY SCREEN

POWER-UP CYCLE

The following pages are displayed in turn when the machine is turned on.

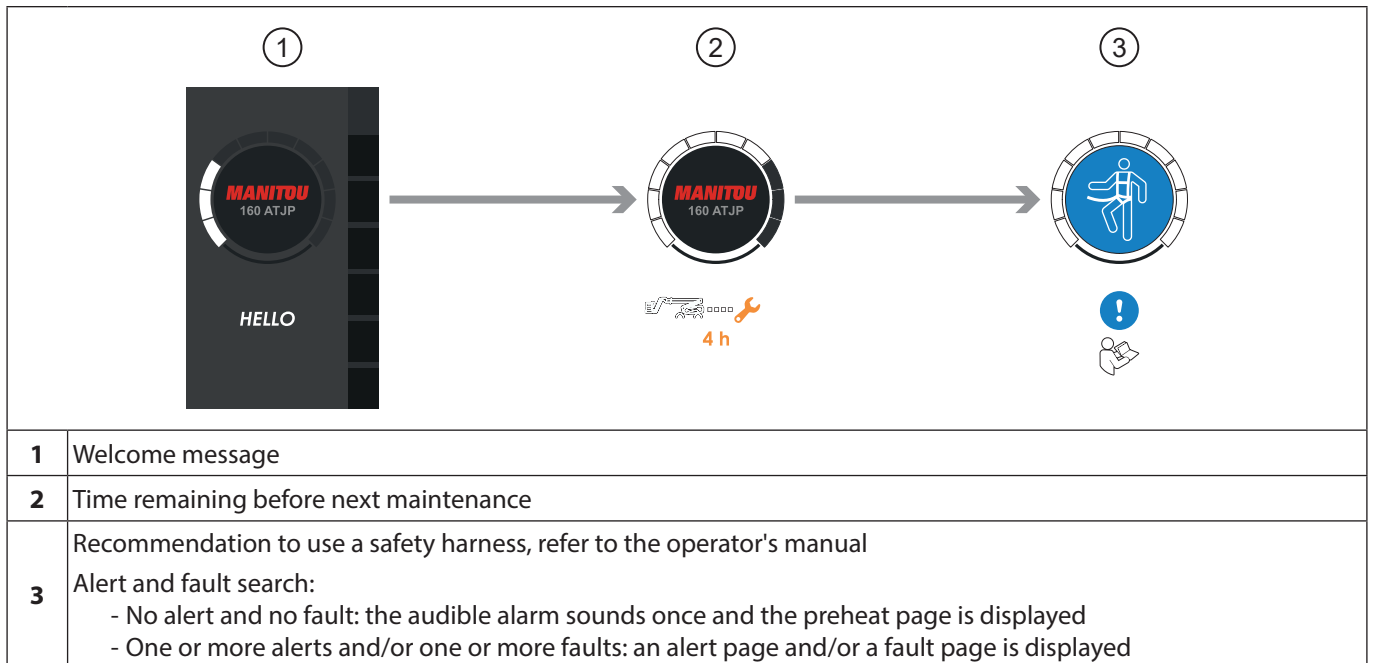

DISPLAY ZONES

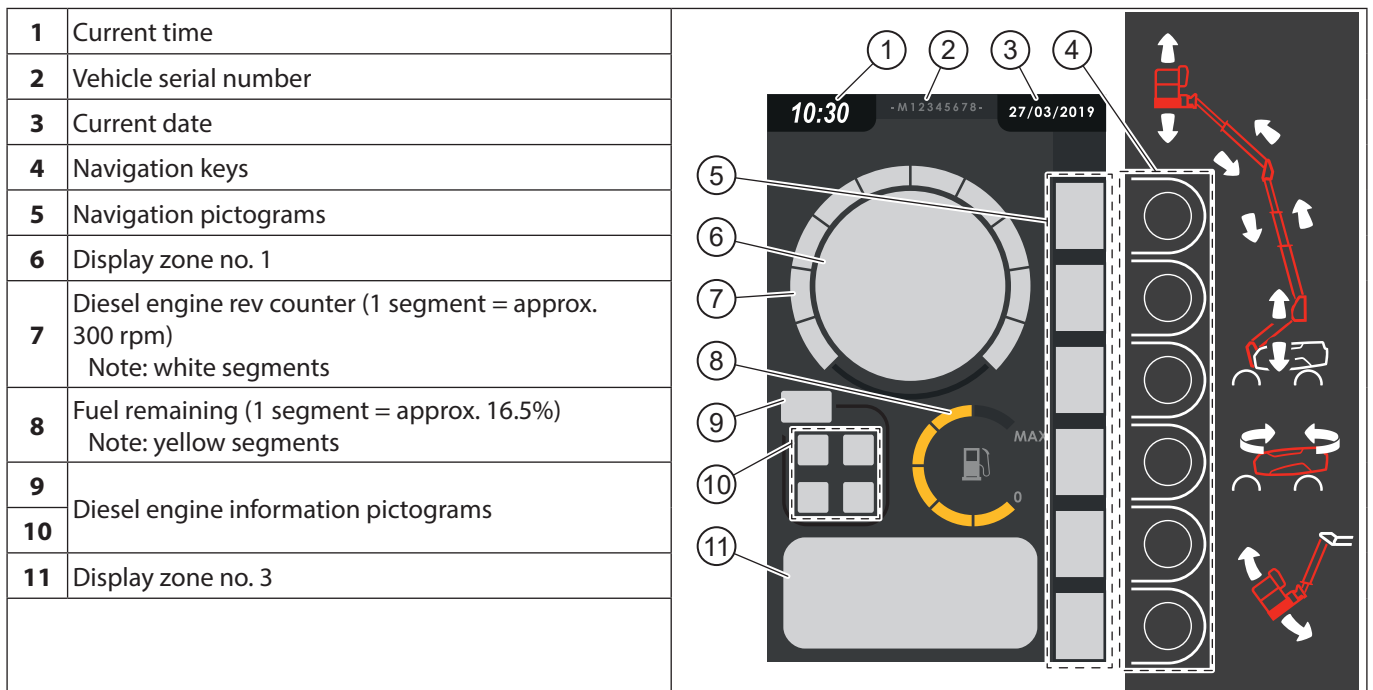





























NAVIGATION PICTOGRAMS

⚠ IMPORTANT ⚠











Consult maintenance personnel when the "maintenance warning" pictogram  (orange background) is displayed.

The navigation keys  activate the controls relating to the navigation pictograms  displayed:

5		Access to menus
		Return to the previous menu
		Validation of the selection
		Update display
		Upward navigation in the menu
		Downward navigation in the menu
		Move left on the page
		Move right on the page
		Move up on the page
		Move down on the page
		Navigation in the menu (pages) activated
		Navigation in the menu (lines) activated
		Write mode
		Increment
		Decrement

5		Validate change
		Cancellation of the modification
		Day/night screen display change
		Quick access to maintenance menu (black background)
		Maintenance warning (orange background), quick access to the maintenance menu
		Quick access to the alert and fault list
		View the fault type
		Filtering of alerts, faults and events
		Deletion of an alert, fault or event display
		Restore factory settings
		Deactivation of automatic exhaust regeneration
		Activation of automatic exhaust regeneration (orange background)
		Start of "stationary machine" exhaust regeneration (orange background)
		"Stationary machine" exhaust regeneration started (orange background)



DIESEL ENGINE INFORMATION PICTOGRAMS

9		No diesel engine fault
		Minor diesel engine fault, ALERT PAGE AND FAULT PAGE
		Major diesel engine fault, ALERT PAGE AND FAULT PAGE
10		Diesel engine stopped or stopping
		Diesel engine starting
		Diesel engine automatic stop system "stop and go" deactivated
		Diesel engine automatic stop system "stop and go" activated
		"Stationary machine" exhaust regeneration required or automatic exhaust regeneration deactivated
		Exhaust regeneration in progress
		Particulate filter fault (DPF)
		Flashing: "stationary machine" exhaust regeneration required or automatic exhaust regeneration deactivated Fixed: "stationary machine" exhaust regeneration in progress

PREHEAT PAGE

The following information is displayed when:

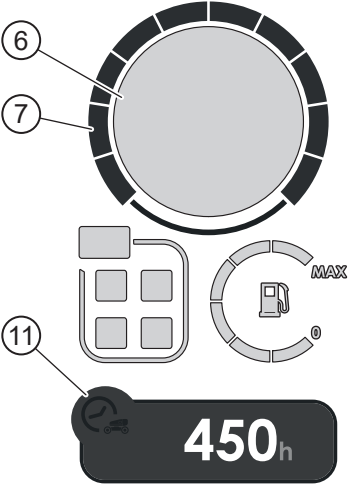
- The diesel engine has not been started.
- There is no alarm.
- There is no fault.

6	Preheat cycle in progress Note: pictogram and orange time indicator		
	Preheat cycle finished: "ok ready to start" (OK, ready to start) is displayed Note: green background		
7	Diesel engine stopped Note: gray segments		
11	Total running time in hours		

WORK PAGE

The following information is displayed when:

- The diesel engine has been started.
- There is no alarm.
- There is no fault.

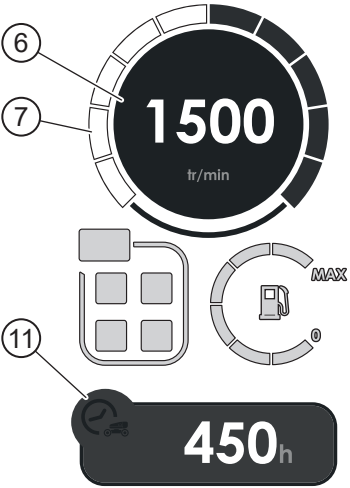
6	Diesel engine rev counter in rpm	
7	Diesel engine rev counter (1 segment = approx. 300 rpm) Note: white segments	
11	Total running time in hours	



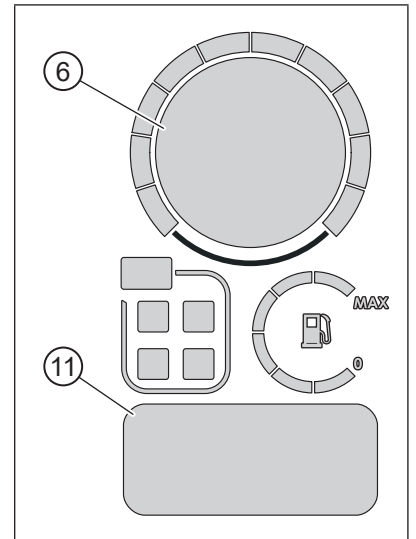

ALERT PAGE AND FAULT PAGE

The following information is displayed when:



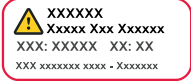

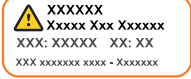

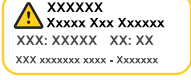
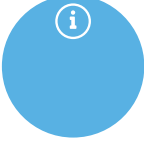
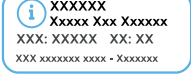

- One or more alerts occur and/or one or more faults occur.

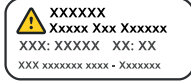

ALERTS

Single alert display		Alert description display		Type	Description
6	 Note: red background with pictogram depending on the alert	11	 Note: red box	Danger	Indicates a hazardous situation which, if not avoided, will result in death or serious injury
6	 Note: orange background with pictogram depending on the alert	11	 Note: orange box	Warning	Indicates a hazardous situation which, if not avoided, may result in death or serious injury
6	 Note: yellow background with pictogram depending on the alert	11	 Note: yellow box	Important	Indicates a hazardous situation which, if not avoided, may result in minor or moderate injury
6	 Note: no display or blue background with pictogram depending on the alert	11	 Note: blue box	Information	Indicates normal operation of the machine or a procedure to be followed that presents no risk of bodily injury

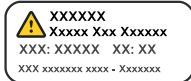
FAULTS

Multiple faults display		Single fault display		Fault description display		Type	Description	
6		Note: gray background with safety pictogram	6		11		Major diesel engine fault	Indicates a situation that, if not avoided, will result in damage to the machine but that does not pose any risk of bodily injury
			6				Major machine fault	Indicates a situation that, if not avoided, will result in damage to the machine but that does not pose any risk of bodily injury
			6				Minor diesel engine fault	Indicates a situation that, if not avoided, may result in damage to the machine but that does not pose any risk of bodily injury
			6				Minor machine fault	Indicates a situation that, if not avoided, may result in damage to the machine but that does not pose any risk of bodily injury

OPERATING THE MACHINE

⚠ IMPORTANT ⚠

The 1 - INSTRUCTIONS AND SAFETY INSTRUCTIONS part must be read and understood before using the machine.

TRANSPORT/WORKING POSITION

TRANSPORT POSITION

The machine is in transport position when:

- The main arm is completely lowered.
- The telescopic arm is completely retracted.
- The telescopic jib arm is completely retracted (280 TJ).
- NOTE: the jib arm may or may not be raised. The turntable and the platform may or may not be turned.

The turntable and the platform are in neutral position when the main arm and the platform are parallel to the machine's chassis with the platform between the 2 rear wheels.

Front, rear, left and right are defined as follows:

- The machine is in transport position.
- The turntable and the platform are in neutral position.
- The operator is in the platform facing the direction of the front wheels.

The tortoise, ramp and hare speeds are only active in transport position.

Note: the activated speed may be limited depending on conditions, refer to the next page.

It is recommended that the turntable and platform are put in neutral position to drive the machine at hare speed.

When driving the machine over a long distance, it is recommended to:

- Place the machine in transport position.
- Put the turntable and platform in neutral position.
- Raise the jib arm slightly for better visibility.
- Drive the machine forward.

WORKING POSITION

⚠ IMPORTANT ⚠

Traveling over rough terrain, on unstable ground, on slopes that are steeper than the maximum authorized chassis tilt (⚠ SPECIFICATIONS) or in any other conditions likely to cause the machine to tip up or become destabilized is prohibited.

The machine is in working transport position when:







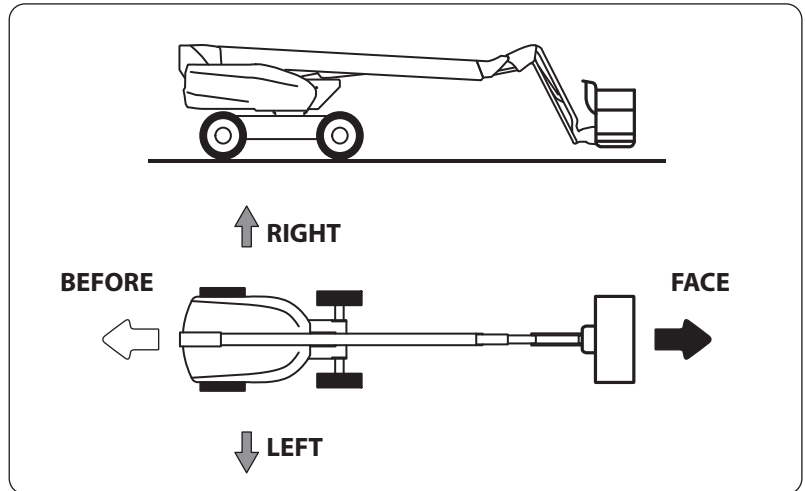





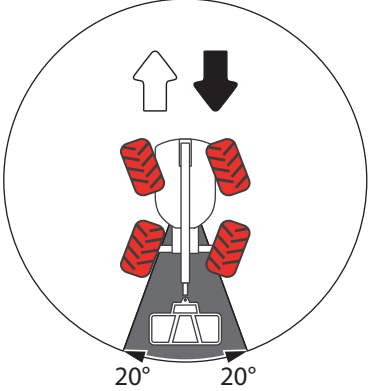



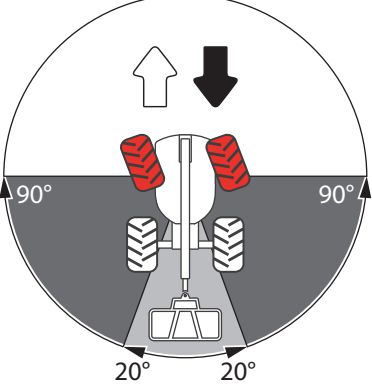



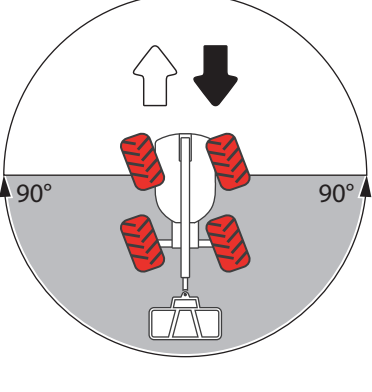

- The main arm is not completely lowered.
- The telescopic arm is not completely retracted.
- The telescopic jib arm is not completely retracted (280 TJ).

Note: the jib arm may or may not be raised. The turntable and the platform may or may not be turned.

The working speed is automatically activated when the machine is in working position.

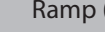

DRIVING SPEED ACTIVATED DEPENDING ON THE STEERING MODE SELECTED, THE DRIVING SPEED SELECTED AND THE POSITION OF THE TURNTABLE (TRANSPORT POSITION ONLY)

		DRIVING SPEED SELECTED		
		Low speed 	Ramp 	High speed 
STEERING MODE SELECTED	POSITION OF THE TURNTABLE	DRIVING SPEED ACTIVATED		
Four steering wheels 	< 20°	Low speed 	Ramp 	Ramp (1) 
	> 20° < 90°	Reduced	Reduced	Reduced (1)
	> 90°	Reduced (1)	Reduced (1)	Reduced (1)
Two steering wheels 	< 20°	Low speed 	Ramp 	Hare (1)  ↑ Ramp (1)  ↓
	> 20° < 90°	Low speed 	Ramp (1) 	Ramp (1) 
	> 90°	Reduced (1)	Reduced (1)	Reduced (1)
Crab steering 	< 20°	Low speed 	Ramp 	Hare (1)  ↑ Ramp (1)  ↓
	> 20° < 90°	Low speed 	Ramp (1) 	Hare (1)  ↑ Ramp (1)  ↓
	> 90°	Reduced (1)	Reduced (1)	Reduced (1)

(1) The driving and turntable rotation functions cannot be activated simultaneously.

Note: slow speed is activated automatically and cannot be selected manually.

OPERATION FROM THE GROUND LEVEL CONTROL PANEL



◀ **CONTROL PANEL AND SAFETY DEVICES ON THE GROUND** for detailed information about the ground controls.

SWITCH ON THE MACHINE

- Ensure that the emergency stop buttons on the ground level control panel, the platform control panel and the remote control unit are in the ON position.
- Battery cut-off option: turn the battery cut-off to the ON position, ▶ OPTIONS: BATTERY CUT-OFF.



- Turn the ignition switch to the ON position.

Result:

- The ground level display screen, ▶ GROUND LEVEL DISPLAY SCREEN.

Note: secondary protection system option SPS, ▶ OPTIONS: SECONDARY PROTECTION SYSTEM SPS.

Note: the horn sounds twice and an alert page is displayed on the ground level display screen when the machine is turned on without starting the diesel engine within 10 seconds.

SWITCH OFF THE MACHINE



- Turn the ignition switch to the OFF position.
- Battery cut-off option: turn the battery cut-off to the OFF position, ▶ OPTIONS: BATTERY CUT-OFF.

START THE DIESEL ENGINE

- Switch on the machine.
- Wait for the preheat cycle to finish, ▶ GROUND LEVEL DISPLAY SCREEN.
- Start the diesel engine, ▶ START BUTTON and ▶ START MODE BUTTON if the outside temperature is below -10 °C.
- If the diesel engine does not start:



- Turn the ignition switch to the OFF position, turn it to the ON position.
- Wait for the preheat cycle to finish and try to start the diesel engine.

Note: consult maintenance personnel if the diesel engine fails to start after several attempts.

SWITCH OFF THE DIESEL ENGINE



Wait several minutes for the diesel engine to cool down before stopping it after intensive use.

- Turn the ignition key to the OFF position  or press the emergency stop button (OFF position).

POSITION THE PLATFORM

- Ensure that the turntable is unlocked, ▶ SAFETY COMPONENTS: TURNTABLE LOCKING PIN.
Note: it is essential that the turntable is locked when the machine is being transported and lifted, ▶ TRANSPORT AND LIFTING: TRANSPORT INSTRUCTIONS and ▶ TRANSPORT AND LIFTING: LIFTING INSTRUCTIONS.
- Start the diesel engine.
- Push and hold the activation switch to the right  (ground level controls position).
- Use the appropriate control buttons to position the platform.
- Release the activation switch.

ACTIVATE SIMULTANEOUS FUNCTIONS

2 machine functions can be activated simultaneously.

Note: the audible warning sounds twice when the machine's functions cannot be activated simultaneously.

EMERGENCY STOP

- Push the emergency stop button into the OFF position.

USE FROM THE PLATFORM CONTROL PANEL

⚠ IMPORTANT ⚠

◀ **CONTROL PANEL AND SAFETY DEVICES IN THE PLATFORM** for detailed information about the platform controls.

Make sure that the platform is level before putting the machine in working position, ▶ OPERATING THE MACHINE: TRANSPORT/WORKING POSITION.
Key lock option for turntable covers: to guarantee access to the emergency controls, it is mandatory to unlock the right-hand turntable cover before using the machine from the platform.

TURN THE MACHINE ON/OFF

◀ OPERATION FROM THE GROUND LEVEL CONTROL PANEL.

START THE DIESEL ENGINE

- Switch on the machine.
 - Wait for the preheat cycle to finish, ▶ PREHEAT INDICATOR LIGHT.
 - Start the diesel engine, ▶ START BUTTON.
Note: ▶ OPERATION FROM THE GROUND LEVEL CONTROL PANEL if the outside temperature is below -10 °C.
 - If the diesel engine does not start:
 - Press the emergency stop button (OFF position), pull it or turn it clockwise and release it to put it in the ON position.
 - Wait for the preheat cycle to finish and try to start the diesel engine.
- Note: consult maintenance personnel if the diesel engine fails to start after several attempts.

SWITCH OFF THE DIESEL ENGINE

⚠ IMPORTANT ⚠

Wait several minutes for the diesel engine to cool down before stopping it after intensive use.

- Push the emergency stop button into the OFF position.

DRIVE, STEER AND BRAKE THE MACHINE

⚠ IMPORTANT ⚠

Always refer to the colors of the arrows on the chassis and on the control panel in the platform before driving/steering the machine.

- Ensure that the turntable is unlocked, ▶ SAFETY COMPONENTS: TURNTABLE LOCKING PIN.
Note: it is essential that the turntable is locked when the machine is being transported and lifted, ▶ TRANSPORT AND LIFTING: TRANSPORT INSTRUCTIONS and ▶ TRANSPORT AND LIFTING: LIFTING INSTRUCTIONS.
- Start the diesel engine.
- Set the driving speed switch to the desired speed.
- Set the steering mode switch to the desired mode.
- Press and hold down the foot switch.
- Use the driving/steering control handle to drive, steer and brake the machine.
- Release the foot switch.

POSITION THE PLATFORM

- Ensure that the turntable is unlocked, ▶ SAFETY COMPONENTS: TURNTABLE LOCKING PIN.
Note: it is essential that the turntable is locked when the machine is being transported and lifted, ▶ TRANSPORT AND LIFTING: TRANSPORT INSTRUCTIONS and ▶ TRANSPORT AND LIFTING: LIFTING INSTRUCTIONS.
- Start the diesel engine.
- Press and hold down the foot switch.
- Use the appropriate switches, buttons and control handles to position the platform.
- Release the foot switch.

ACTIVATE SIMULTANEOUS FUNCTIONS

4 machine functions can be activated simultaneously.

Note: the audible warning sounds twice when the machine's functions cannot be activated simultaneously.

EMERGENCY STOP

- Push the emergency stop button into the OFF position.

OPERATION FROM THE REMOTE CONTROL UNIT

⚠ IMPORTANT ⚠

◀ **REMOTE CONTROL UNIT** for detailed information about the remote controls.

It is essential that the turntable is locked when the remote control unit is being used, ▶ TRANSPORT AND LIFTING: TRANSPORT INSTRUCTIONS and ▶ TRANSPORT AND LIFTING: LIFTING INSTRUCTIONS.

The remote control unit is only activated when:

- The turntable angle is less than 90° (to left or right) in relation to the neutral position.
- The angle of the main jib is 15° maximum in relation to the completely lowered position.
- The telescopic arm is completely retracted.
- The telescopic jib arm is completely retracted (280 TJ).

TURN THE MACHINE ON/OFF

◀ OPERATION FROM THE GROUND LEVEL CONTROL PANEL.

START THE DIESEL ENGINE

- Switch on the machine.
- Wait for the preheat cycle to finish, ▶ GROUND LEVEL DISPLAY SCREEN.
- Start the engine, ▶ START BUTTON.

Note: ▶ OPERATION FROM THE GROUND LEVEL CONTROL PANEL if the outside temperature is below -10 °C.

- If the diesel engine does not start:
 - Press the emergency stop button (OFF position), pull it or turn it clockwise and release it to put it in the ON position.
 - Wait for the preheat cycle to finish and try to start the diesel engine.

Note: consult maintenance personnel if the diesel engine fails to start after several attempts.

SWITCH OFF THE DIESEL ENGINE

⚠ IMPORTANT ⚠

Wait several minutes for the diesel engine to cool down before stopping it after intensive use.

- Push the emergency stop button into the OFF position.

POSITION THE PLATFORM

- Press and hold down the activation button.
- Use the appropriate buttons to position the platform.
- Release the activation button.

ACTIVATE SIMULTANEOUS FUNCTIONS

2 machine functions can be activated simultaneously.

Note: the audible warning sounds twice when the machine's functions cannot be activated simultaneously.

EMERGENCY STOP

- Push the emergency stop button into the OFF position.



DIESEL ENGINE AUTOMATIC STOP SYSTEM "STOP AND GO"

Note: the illustrations show a standard platform without 260 TJ+ gate.



Note: diesel engine information pictograms indicate the status of the diesel engine and the system, GROUND LEVEL DISPLAY SCREEN: DISPLAY ZONES: DIESEL ENGINE INFORMATION PICTOGRAMS.

DIESEL ENGINE AUTOMATIC STOP

The diesel engine is stopped automatically if the following conditions are met:

- The foot switch  has been released for at least 30 seconds (1).
- The activation switch  has been released for at least 30 seconds (1).
- The activation button  has been released for at least 30 seconds (1).
- The diesel engine has been started for at least 10 minutes (1).
- The main arm is not completely lowered (1).
- The battery voltage is "normal" (1).
- The left-hand turntable cover is closed (1).
- The machine's last function was activated using the platform control panel.
- No automatic or "stationary machine" exhaust regeneration is in progress.
- The secondary protection system warning SPS (option) is not in progress.
- The electric generator (option) is stopped.

Result:

- The preheat indicator light  flashes.
- An alert page is displayed, GROUND LEVEL DISPLAY SCREEN: ALERT PAGE AND FAULT PAGE.
- The orange rotating beacon light  comes on (cycle: on = 1 second, off = 1 second).

Note: when the permanent orange rotating beacon light is activated, the orange rotating beacon light changes from "continuous operation" status to "cycle: on = 1 second, off = 1 second" status.

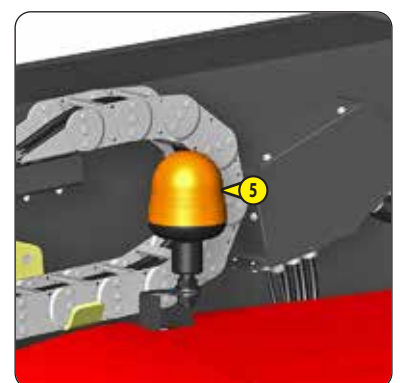
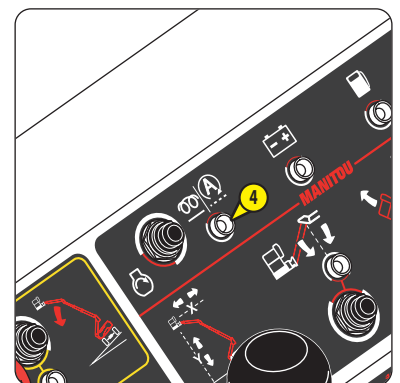
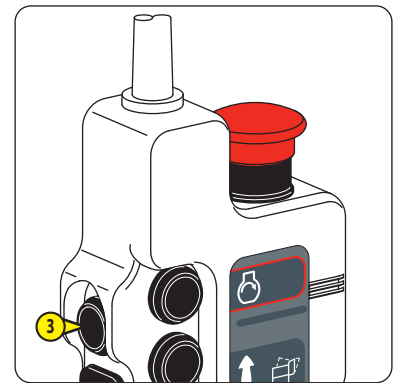
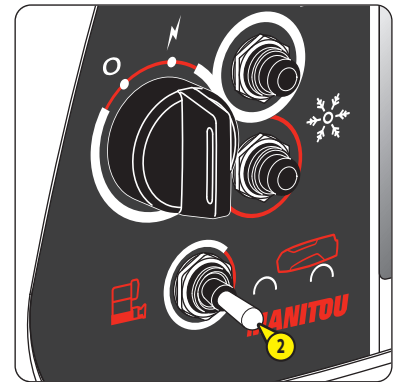
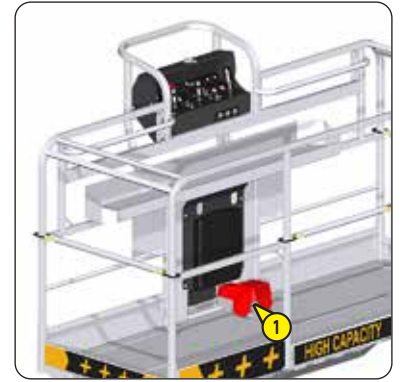

(1) This information can be checked on the ground level display screen:

- Press the navigation key corresponding to the navigation pictogram  (menu access).
- Select the "engine" menu and then the "stop&go information" sub-menu.

DIESEL ENGINE MANUAL RESTART

⚠ IMPORTANT ⚠

It is recommended to restart the diesel engine when a low battery fault occurs:

- The battery indicator light **6** flashes.
- The audible alarm sounds intermittently.

- A fault page is displayed, GROUND LEVEL DISPLAY SCREEN: ALERT PAGE AND FAULT PAGE.

- Press and hold down the foot switch **1**.

or

- Push and hold the activation switch **2** to the right  (ground level controls position).

or

- Press and hold down the activation button **3**.

Note: the left-hand turntable cover must be closed (1).

Note: when preheating is required, the preheat indicator light **4** comes on and the preheat page is displayed, GROUND LEVEL DISPLAY SCREEN: PREHEAT PAGE.

Result:

- The diesel engine starts.
- The preheat indicator light **4** goes out.
- The battery indicator light **6** goes out.
- The audible alarm stops.
- The fault page is no longer displayed.
- The orange rotating beacon light **5** goes out.

Note: when the permanent orange rotating beacon light is activated, the orange rotating beacon light changes from "cycle: on = 1 second, off = 1 second" status to "continuous operation" status.

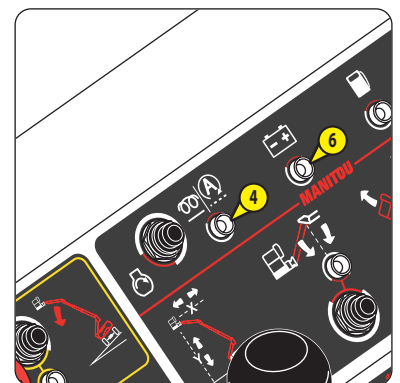
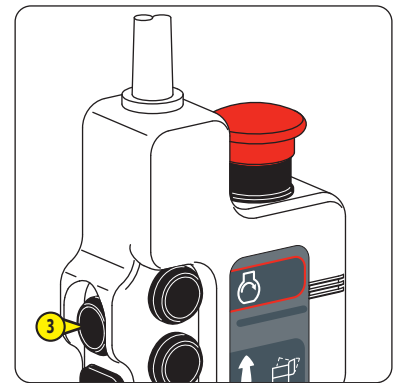
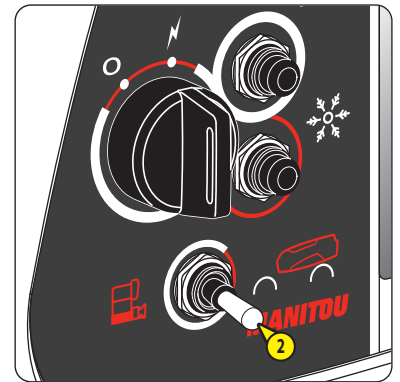
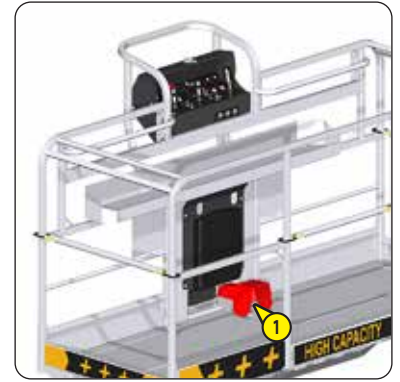

(1) This information can be checked on the ground level display screen:

- Press the navigation key corresponding to the navigation pictogram  (menu access).
- Select the "engine" menu and then the "stop&go information" sub-menu.

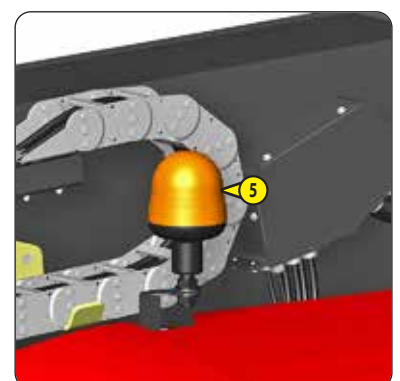

DIESEL ENGINE AUTOMATIC RESTART

The diesel engine is started automatically if the following conditions are met:

- The foot switch **1** is released.
- The activation switch **2** is released.
- The activation button **3** is released.
- The battery voltage is "critical" (1).
- The main arm is not completely lowered (1).
- The left-hand turntable cover is closed (1).

Note: the battery indicator light **6** flashes. The audible alarm sounds intermittently. A fault page is displayed, GROUND LEVEL DISPLAY SCREEN: ALERT PAGE AND FAULT PAGE.

Note: when preheating is required, the preheat indicator light **4** comes on and the preheat page is displayed, GROUND LEVEL DISPLAY SCREEN: PREHEAT PAGE.

Result:

- The diesel engine starts.
- The preheat indicator light **4** goes out.
- The battery indicator light **6** goes out.
- The audible alarm stops.
- The fault page is no longer displayed.
- The orange rotating beacon light **5** goes out.
- The diesel engine automatic stop system "stop and go" is deactivated. It will be automatically reactivated when the machine is turned off and then turned back on with "normal" battery voltage (1).

Note: when the permanent orange rotating beacon light is activated, the orange rotating beacon light changes from "cycle: on = 1 second, off = 1 second" status to "continuous operation" status.

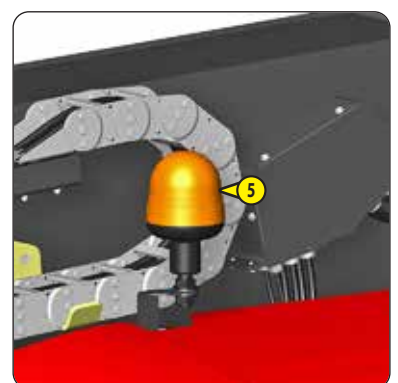
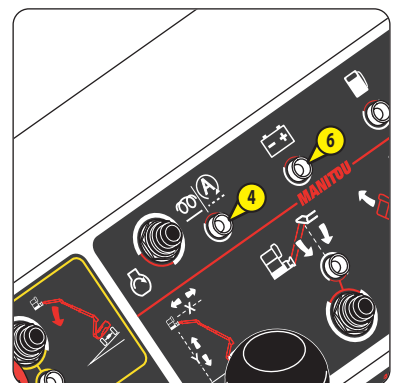
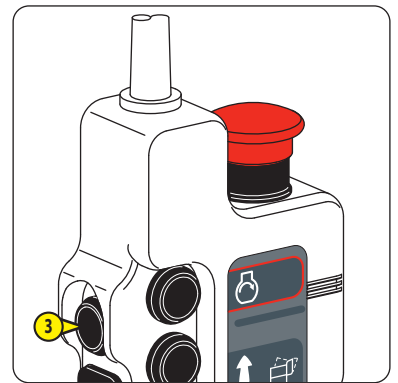
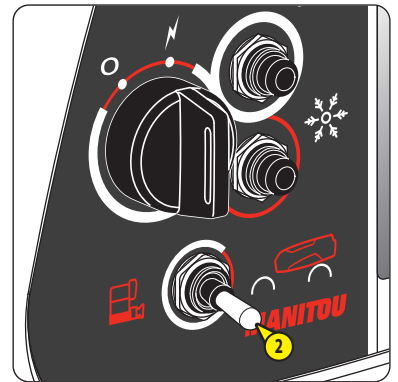
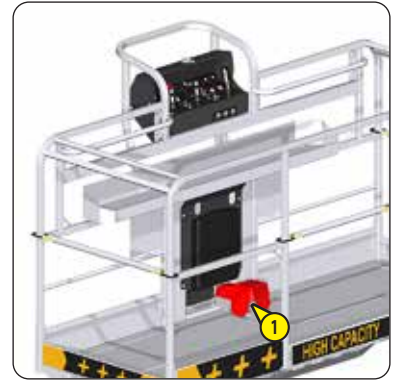

(1) This information can be checked on the ground level display screen:

- Press the navigation key corresponding to the navigation pictogram (menu access).
- Select the "engine" menu and then the "stop&go information" sub-menu.

AUTOMATIC EXHAUST REGENERATION

⚠ IMPORTANT ⚠

Deactivate automatic exhaust regeneration when the machine is in a dusty or flammable environment.
Automatic exhaust regeneration must only be stopped if absolutely necessary: risk of engine damage.

⚠ IMPORTANT ⚠

During automatic exhaust regeneration:

- Ensure that the machine is in a dust-free and non-flammable environment.
- Do not leave the machine unattended.
- Do not open the left-hand turntable cover.
- Do not go near the exhaust pipe: risk of burns.

Automatic exhaust regeneration is activated each time the machine is switched on.

It starts automatically when the particulate filter (DPF) is clogged:

- The exhaust regeneration indicator light ① comes on.
- The audible alarm sounds once.
- The pictogram ②  (exhaust regeneration in progress) is displayed.

Note:  GROUND LEVEL DISPLAY SCREEN.

Note: the machine can be used during automatic exhaust regeneration.

STOP AUTOMATIC EXHAUST REGENERATION IN PROGRESS AND/OR DEACTIVATE AUTOMATIC EXHAUST REGENERATION

From the platform control panel:

- Press and release the exhaust regeneration button ②.



Result:

- When automatic exhaust regeneration is started: the exhaust regeneration indicator light ① goes out.
- The audible alarm sounds once.

From the ground level control panel:

- Press the navigation key corresponding to the navigation pictogram ③  (deactivation of automatic exhaust regeneration).

Result:

- The navigation pictogram ④  (activation of automatic exhaust regeneration (orange background)) is displayed.
- The pictogram ⑤  (automatic exhaust regeneration deactivated) is displayed.
- The pictogram ⑥  (automatic exhaust regeneration deactivated) flashes.
- A warning page ⑦ is displayed.

Note:  GROUND LEVEL DISPLAY SCREEN.

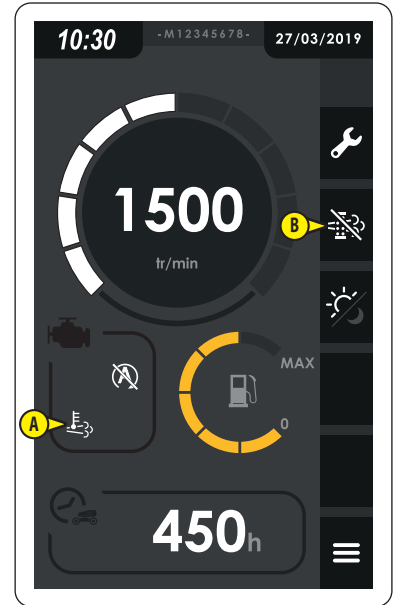
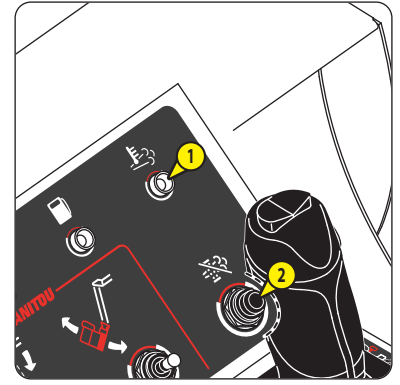

REACTIVATE AUTOMATIC EXHAUST REGENERATION

From the platform control panel:

- Press the exhaust regeneration button **2** for 2 seconds and then release it.



Result:

- The audible alarm sounds twice.

From the ground level control panel:

- Press the navigation key corresponding to the navigation pictogram **C**  (activation of automatic exhaust regeneration (orange background)).

Result:

- The navigation pictogram **B**  (deactivation of automatic exhaust regeneration) is displayed.
- The pictogram **D**  (automatic exhaust regeneration deactivated) is no longer displayed.
- The pictogram **E**  (automatic exhaust regeneration deactivated) is no longer displayed.
- The alert page **F** is no longer displayed.

Note:  GROUND LEVEL DISPLAY SCREEN.

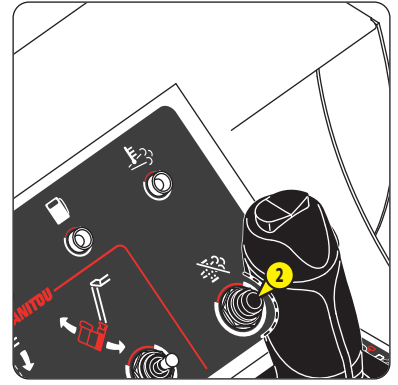

"STATIONARY MACHINE" EXHAUST REGENERATION

⚠ IMPORTANT ⚠

Before starting "stationary machine" exhaust regeneration.





- Park the machine outside of any building, even properly ventilated, in a dust-free and non-flammable environment.
- Make sure that the machine has battery life of at least 1 hour.
- Make sure that the left-hand turntable cover is properly closed.

⚠ IMPORTANT ⚠

During "stationary machine" exhaust regeneration:

- Do not leave the machine unattended.
- Do not open the left-hand turntable cover.
- Do not go near the exhaust pipe: risk of burns.

When "stationary machine" exhaust regeneration is required:

- The fault indicator light **I** comes on.
- The audible alarm sounds intermittently.
- The pictogram **A**  (minor diesel engine fault) is displayed.
- The pictogram **B**  ("stationary machine" exhaust regeneration required) is displayed.
- The pictogram **C**  ("stationary machine" exhaust regeneration required) flashes.
- A fault page **D** is displayed.
- The navigation pictogram **E**  (start of "stationary machine" exhaust regeneration (orange background)) flashes.

Note:  GROUND LEVEL DISPLAY SCREEN.

START THE "STATIONARY MACHINE" EXHAUST REGENERATION INDICATED BY THE SYSTEM

- Press the navigation key corresponding to the navigation pictogram **E**  (start of "stationary machine" exhaust regeneration (orange background)).
- Follow the instructions on the ground level display screen.

Note:  GROUND LEVEL DISPLAY SCREEN.

Note: the audible alarm stops when "stationary machine" exhaust regeneration is started.

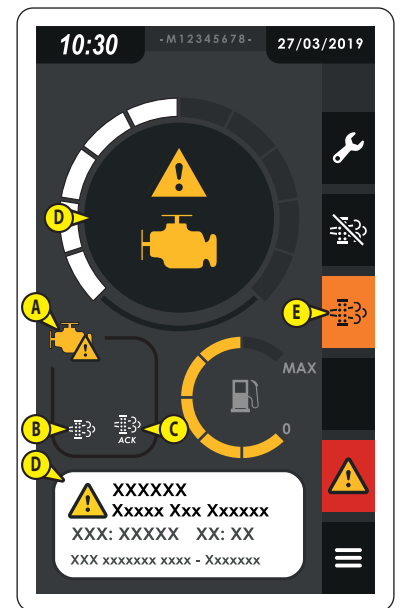
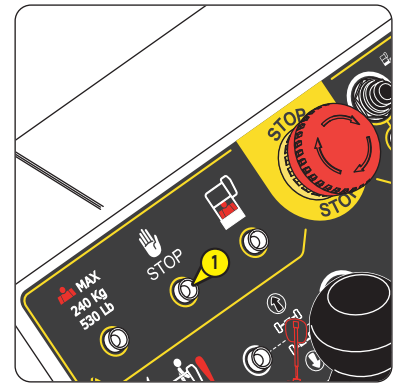

START "STATIONARY MACHINE" EXHAUST REGENERATION MANUALLY





It is possible to start "stationary machine" exhaust regeneration manually:

- Press the navigation key corresponding to the navigation pictogram **F**  (menu access).
- Select the "engine" menu and then the "forced regeneration" sub-menu.
- Follow the instructions on the ground level display screen.

Note:  GROUND LEVEL DISPLAY SCREEN.

"STATIONARY MACHINE" EXHAUST REGENERATION IN PROGRESS

When "stationary machine" exhaust regeneration is in progress:

- The exhaust regeneration indicator light **2** is on.
- The pictogram **G**  (no diesel engine fault) is displayed.
- The pictogram **H**  (exhaust regeneration in progress) is displayed.
- The pictogram **C**  ("stationary machine" exhaust regeneration in progress) is displayed.
- The navigation pictogram **I**  ("stationary machine" exhaust regeneration started (orange background)) is displayed.
- When the "stationary machine" exhaust regeneration is indicated by the system: the fault page is no longer displayed.

Note:  GROUND LEVEL DISPLAY SCREEN.

Note: all the machine's functions are locked until the end of "stationary machine" exhaust regeneration.

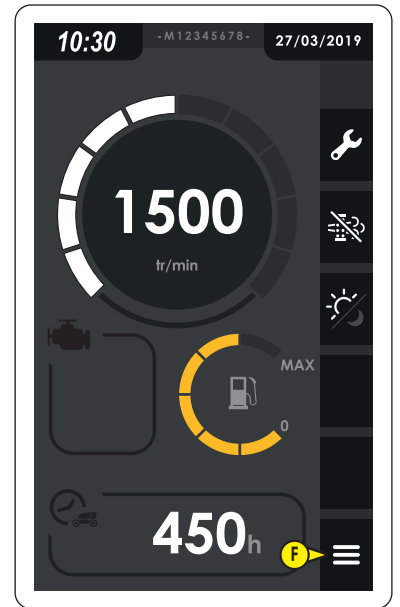
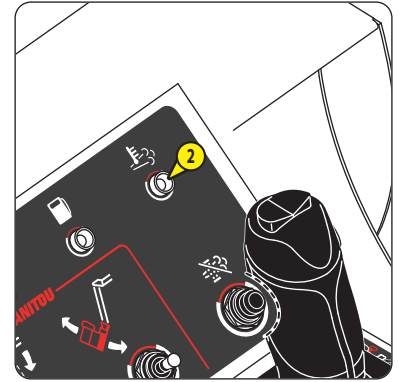













LOCKED FUNCTIONS

Some machine functions are locked :





- When the platform load has reached maximum load capacity (overload alarm).
- If the tilt of the chassis is greater than the maximum authorized value (tilt warning).
- When an oscillating axle locking fault occurs (oscillation lock fault).
- When one of the cables of the telescopic arm is slackened or cut (telescopic arm cable fault).

MACHINE IN TRANSPORT POSITION

FROM THE GROUND LEVEL CONTROL PANEL AND THE CONTROL PANEL IN THE PLATFORM

	WARNING OVERLOAD	TILT WARNING	TELESCOPIC ARM CABLE FAULT
		OSCILLATION LOCK FAULT	
Extend the telescopic jib arm - only for 280 TJ			
Tilt the platform/jib arm (up/down)			
Raise/lower the jib arm			
Extend the telescopic arm			
Raise the main arm			
Turn the turntable (to the left/right)			

FROM THE PLATFORM CONTROL PANEL

	WARNING OVERLOAD	TILT WARNING	TELESCOPIC ARM CABLE FAULT
		OSCILLATION LOCK FAULT	
Drive (forward/backward)			
Steer (to the left/right)			
Turn the platform (to the left/right)			
Tilt the platform (up/down) - only for 280 TJ			

MACHINE IN WORKING POSITION

FROM THE GROUND LEVEL CONTROL PANEL AND THE CONTROL PANEL IN THE PLATFORM

		WARNING OVERLOAD	TILT WARNING	TELESCOPIC ARM CABLE FAULT
			OSCILLATION LOCK FAULT	
Extend the telescopic jib arm - only for 280 TJ		🔒	🔒	
Retract the telescopic jib arm - only for 280 TJ		🔒		
Tilt the platform/jib arm (up/down)		🔒	🔒	
Raise/lower the jib arm - 260 TJ+		🔒		
Raise/lower the jib arm - 280 TJ	Telescopic jib arm retracted	🔒		
	Telescopic jib arm extended	🔒	🔒	
Extend the telescopic arm		🔒	🔒	🔒
Retract the telescopic arm		🔒		
Raise the main arm	Telescopic arm retracted	🔒	🔒	
	Telescopic arm extended	🔒	🔒	🔒
Lower the main arm	Telescopic arm retracted	🔒		
	Telescopic arm extended	🔒	🔒	🔒
Turn the turntable (to the left/right)	Telescopic arm retracted	🔒		
	Telescopic arm extended	🔒	🔒	

FROM THE PLATFORM CONTROL PANEL

		WARNING OVERLOAD	TILT WARNING	TELESCOPIC ARM CABLE FAULT
			OSCILLATION LOCK FAULT	
Drive (forward/backward)		🔒	🔒	
Steer (to the left/right)		🔒	🔒	
Turn the platform (to the left/right)		🔒		

EMERGENCY CONTROLS

⚠ IMPORTANT ⚠

This procedure should be read and fully understood by the operator and any other persons likely to be involved with working on the machine in the event of a breakdown or a person getting trapped in the platform.

SHOULD THE USER FEEL ILL - PRIORITY CONTROLS FROM THE GROUND

If the operator in the platform should fall ill or find himself incapable of maneuvering, somebody on the ground can take over the machine controls using the ground level control panel.

1- If the diesel engine has been started:

- Push and hold the activation switch ① to the right  (ground level controls position).
- Use the appropriate control buttons to position the platform.
- Release the activation switch.

2- If the diesel engine has stopped and the emergency stop button in the platform is in the ON position (the ground level display screen is on):

- Start the diesel engine.
- Push and hold the activation switch ① to the right  (ground level controls position).
- Use the appropriate control buttons to position the platform.
- Release the activation switch.

3- If the diesel engine has stopped and the emergency stop button in the platform is in the OFF position (the ground level display screen is off):

- Push and hold the activation switch ① to the right  (ground level controls position).
- Wait for the preheat cycle to finish and start up the diesel engine.
- Use the appropriate control buttons to position the platform.
- Release the activation switch.

4- If the control buttons are not working:

- ⏪ IF THERE IS A BREAKDOWN - EMERGENCY CONTROLS FROM THE GROUND.

IF THERE IS A BREAKDOWN - EMERGENCY CONTROLS FROM THE PLATFORM

⚠ IMPORTANT ⚠

The backup pump should be activated for a maximum of 4 minutes, then wait 10 minutes before reactivating the pump for a new 4 minute cycle.

Do not try to use the functions simultaneously.

Activate the machine's functions using the backup pump when the diesel engine is not operational:

- Press and hold down the backup pump button ①.
- Use the appropriate switch or control handle to position the platform.
- Release the backup pump button.

Note: it is not possible to drive/steer the machine.

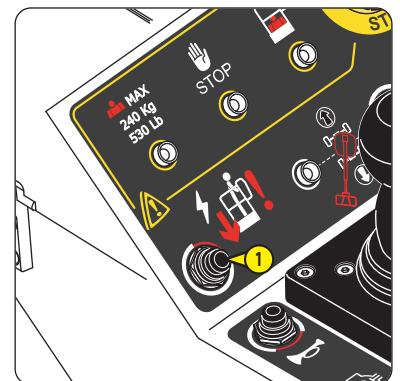
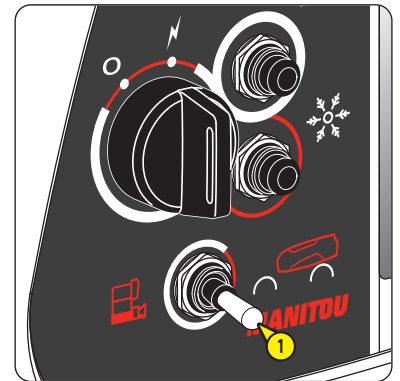

IF THERE IS A BREAKDOWN - EMERGENCY CONTROLS FROM THE GROUND

⚠ IMPORTANT ⚠

The tilt warning and overload alarm may no longer be active when the emergency controls are in use. Activation of functions likely to tip over or imbalance the machine is prohibited.
 The backup pump should be activated for a maximum of 4 minutes, then wait 10 minutes before reactivating the pump for a new 4 minute cycle.

Note: the illustrations show a 260 TJ+.

Activate the machine's functions using the backup pump when the control system is not operational:

- Open the right-hand turntable cover.
- Battery cut-off option: make sure that the battery cut-off is in the ON position.
- Locate the various components of the emergency controls:
 - Backup pump button ①.
 - Proportional distributor ② and manual controls ②A to ②E.
 - Lever ③.
 - Secondary distributor ④ and manual valve ④A.
- Activate the machine's functions described on the following pages to position the platform.

Note: ⏪ STICKERS: BACKUP PUMP ⑤ and ⏪ STICKERS: EMERGENCY CONTROL PROCEDURE ⑥ and ⑦.

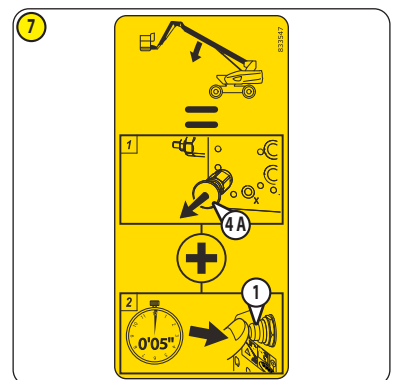
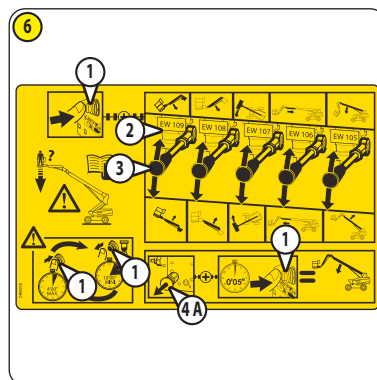
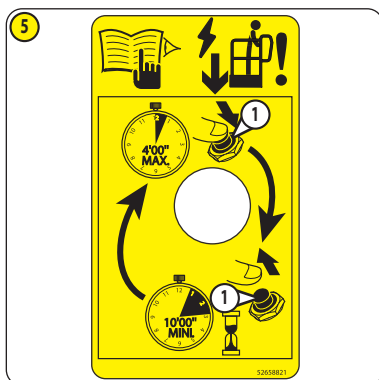
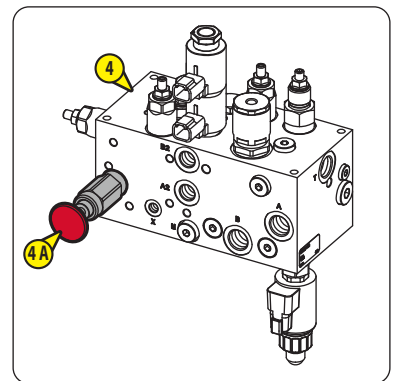
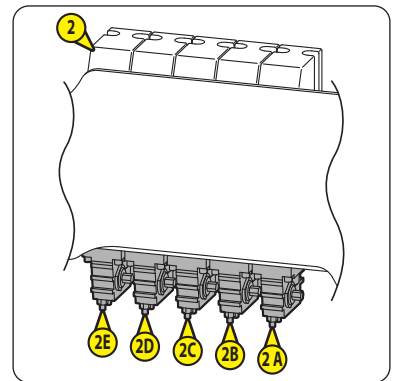
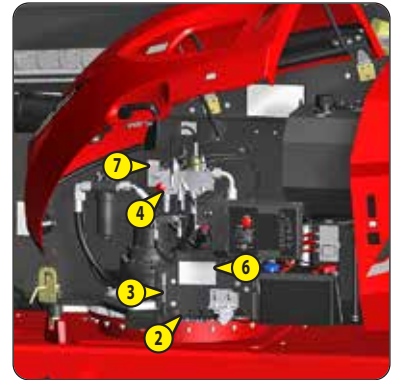

EMERGENCY CONTROLS WITH THE PROPORTIONAL DISTRIBUTOR ②

A- RAISE THE MAIN ARM

- 1- Place the lever ③ on the manual control ②A.
- 2- Press and hold down the backup pump button ①.
- 3- Push the lever down to raise the main arm, stop when the desired position is reached. Release the backup pump button.

Note: remove the lever, put it back in place and close the right-hand turntable cover when no other machine functions are necessary.

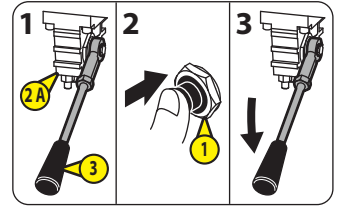

B- LOWER THE MAIN ARM

- 1- Place the lever ③ on the manual control ②A.
- 2- Press and hold down the backup pump button ①.
- 3- Pull the lever up to lower the main arm, stop when the desired position is reached. Release the backup pump button.

Note: remove the lever, put it back in place and close the right-hand turntable cover when no other machine functions are necessary.

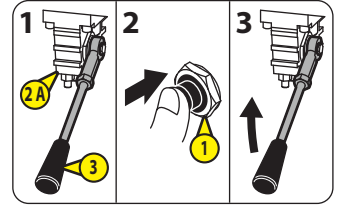

C- EXTEND THE TELESCOPIC ARM

- 1- Place the lever ③ on the manual control ②B.
- 2- Press and hold down the backup pump button ①.
- 3- Push the lever down to extend the telescopic arm, stop when the desired position is reached. Release the backup pump button.

Note: remove the lever, put it back in place and close the right-hand turntable cover when no other machine functions are necessary.

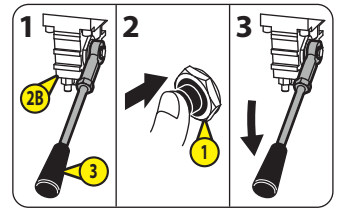

D- RETRACT THE TELESCOPIC ARM

- 1- Place the lever ③ on the manual control ②B.
- 2- Press and hold down the backup pump button ①.
- 3- Pull the lever up to retract the telescopic arm, stop when the desired position is reached. Release the backup pump button.

Note: remove the lever, put it back in place and close the right-hand turntable cover when no other machine functions are necessary.

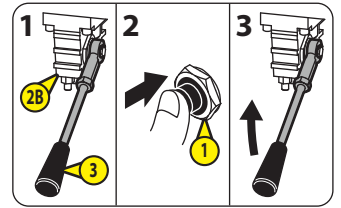

E- TURN THE TURNTABLE TO THE LEFT

- 1- Place the lever ③ on the manual control ②C.
- 2- Press and hold down the backup pump button ①.
- 3- Push the lever down to turn the turntable to the left, stop when the desired position is reached. Release the backup pump button.

Note: remove the lever, put it back in place and close the right-hand turntable cover when no other machine functions are necessary.

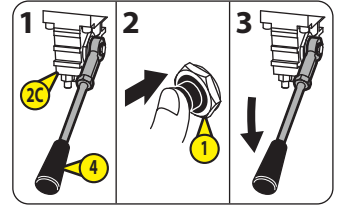

F- TURN THE TURNTABLE TO THE RIGHT

- 1- Place the lever ③ on the manual control ②C.
- 2- Press and hold down the backup pump button ①.
- 3- Pull the lever up to turn the turntable to the right, stop when the desired position is reached. Release the backup pump button.

Note: remove the lever, put it back in place and close the right-hand turntable cover when no other machine functions are necessary.

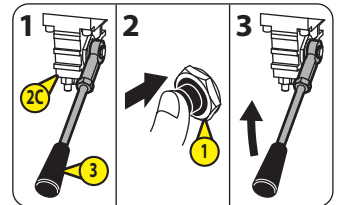

G- RAISE THE JIB ARM

- 1- Place the lever **3** on the manual control **2D**.
- 2- Press and hold down the backup pump button **1**.
- 3- Push the lever down to raise the jib arm, stop when the desired position is reached. Release the backup pump button.

Note: remove the lever, put it back in place and close the right-hand turntable cover when no other machine functions are necessary.

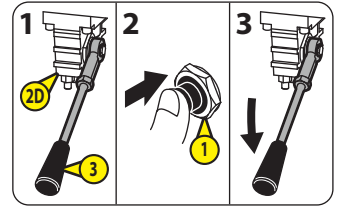

H- LOWER THE JIB ARM

- 1- Place the lever **3** on the manual control **2D**.
- 2- Press and hold down the backup pump button **1**.
- 3- Pull the lever up to lower the jib arm, stop when the desired position is reached. Release the backup pump button.

Note: remove the lever, put it back in place and close the right-hand turntable cover when no other machine functions are necessary.

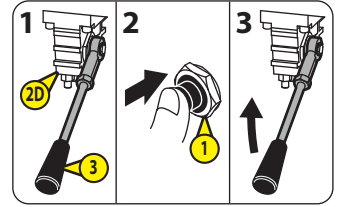

I - TILT THE PLATFORM/JIB ARM UP

- 1- Place the lever **3** on the manual control **2E**.
- 2- Press and hold down the backup pump button **1**.
- 3- Push the lever down to tilt the platform/jib arm up, stop when the desired position is reached. Release the backup pump button.

Note: remove the lever, put it back in place and close the right-hand turntable cover when no other machine functions are necessary.

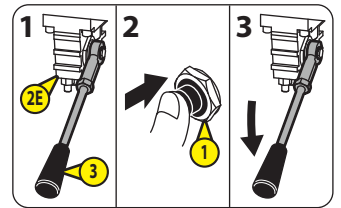

J - TILT THE PLATFORM/JIB ARM DOWN

- 1- Place the lever **3** on the manual control **2E**.
- 2- Press and hold down the backup pump button **1**.
- 3- Pull the lever up to tilt the platform/jib arm down, stop when the desired position is reached. Release the backup pump button.

Note: remove the lever, put it back in place and close the right-hand turntable cover when no other machine functions are necessary.

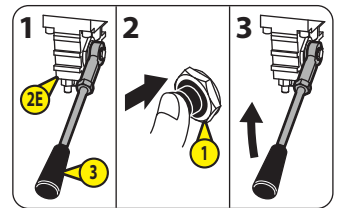

EMERGENCY CONTROLS WITH THE SECONDARY DISTRIBUTOR **4**

A- LOWER THE MAIN ARM

- 1- Pull and hold the manual valve **4A**.
- 2- Press the backup pump button **1** and hold it down for 5 seconds, then release it. Release the manual valve when the main arm is fully lowered.

Note: correct the platform/jib arm tilt if necessary, EMERGENCY CONTROLS WITH THE MAIN DISTRIBUTOR **2**.

Note: close the right-hand turntable cover when no other machine functions are necessary.

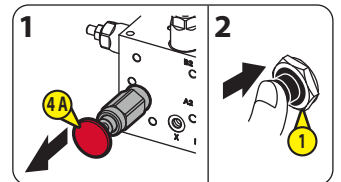

STANDARD EQUIPMENT

OSCILLATING FRONT AXLE

⚠ IMPORTANT ⚠

*When driving the machine in working position, only 3 wheels could be in contact with the ground and the machine may tip over (illustration **A**).*

B: axle oscillation is unlocked when the machine is in transport position.

C: axle oscillation is locked when the machine is in working position.

Note: some machine functions are locked when an oscillating axle locking fault occurs, **⚠ OPERATING THE MACHINE. LOCKED FUNCTIONS.**

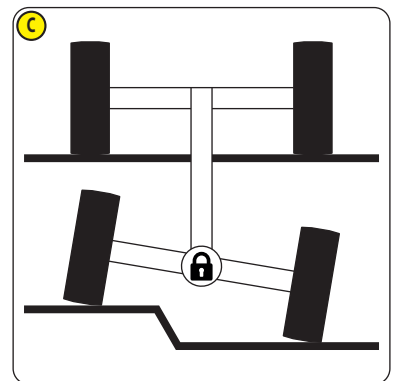
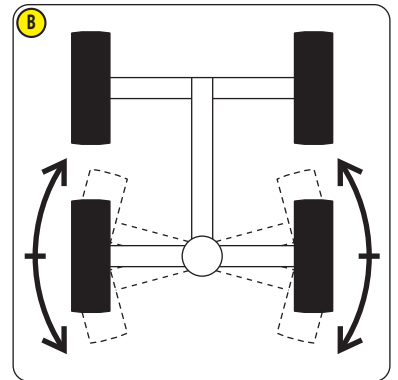
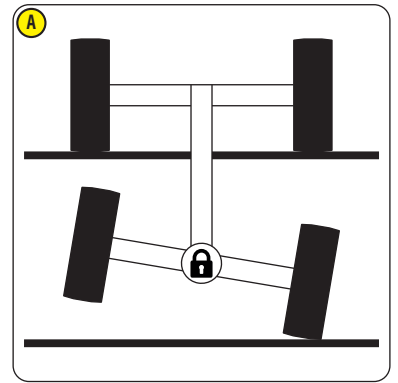

OPTIONS

KEY LOCK FOR TURNTABLE COVERS

⚠ IMPORTANT ⚠

To guarantee access to the emergency controls, it is mandatory to unlock the right-hand turntable cover before using the machine from the platform.

BATTERY CUT-OFF

2 positions:

- Off "OFF": the handle ① is vertical.
- On "ON": the handle ① is horizontal.

Note: ⚠ STICKERS: BATTERY CUT-OFF ③A.



230 V ELECTRIC POWER SOCKET IN THE PLATFORM

Note: the illustrations show a 260 TJ+ with a standard platform without gate.

This option includes:

- 1 plug ① at the rear of the turntable.
- 3 electric power sockets ② in the platform.
- 1 electric unit ③A with 1 30 mA residual-current circuit breaker.

INSTRUCTIONS: ELECTRIC POWER SOCKET IN THE PLATFORM

⚠ IMPORTANT ⚠

Connect the plug to a 230 V/50 Hz power source delivering 16 A.

Only connect electrical appliances that work with 230 V/50 Hz, 16 A maximum.

Do not connect extension cords, power supply bars or plugs with multiple sockets to the electric power socket(s).

- Connect the plug ① to a power source.
- Plug 1, 2 or 3 electrical appliances into the power socket(s) ②.
- Power on the electrical appliances.
- Power down the electrical appliances when the work has been completed.
- Disconnect the electrical plug.

INSTRUCTIONS: RESIDUAL-CURRENT CIRCUIT BREAKER

To reset the residual-current circuit breaker:

- Turn off the power to the electrical appliance.
- Put the machine in transport position, ⚠ OPERATING THE MACHINE: TRANSPORT/WORKING POSITION.
- Fully lower the jib arm.
- Open the electrical box cover panel ③A.
- Push the switch ③B to the ON position.

Result:

- The switch must remain in the ON position, the indicators ③C and ③D should be red.
- Close the electrical box cover panel.

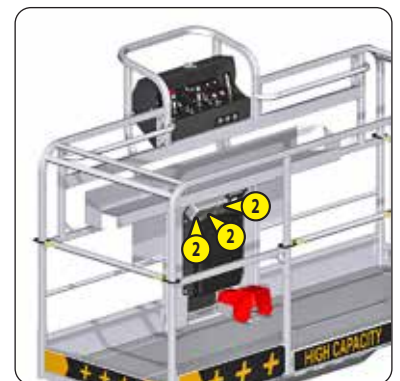

BATTERY HEATER

⚠ IMPORTANT ⚠

Plug the battery heater to a 230 V/50 Hz power source delivering 16 A protected by a 30 mA residual-current circuit breaker.

The machine should be switched off before connecting the battery heater.

The battery heater is designed to heat the battery when the outside temperature is below -10 °C.

- Open the right-hand turntable cover.
- Locate the electrical plug ①.
- Connect it to a power source.
- Wait for the desired heating time and disconnect it.
- Close the right-hand turntable cover.

Note: the heating time depends on the ambient temperature and other factors.
Adjust the heating time, observing the conditions for starting the diesel engine.

Note: the illustration shows 2 plugs for the battery heater (option) and for the hydraulic oil heater (option) with the corresponding stickers ① and ②.

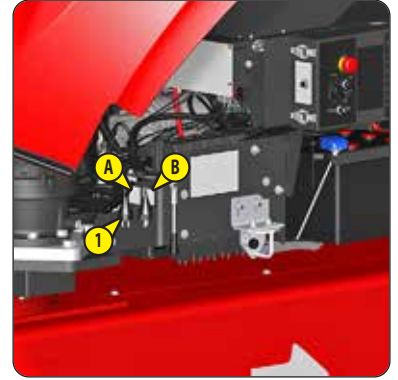

HYDRAULIC OIL HEATER

⚠ IMPORTANT ⚠

Plug the hydraulic oil heater to a 230 V/50 Hz power source delivering 16 A protected by a 30 mA residual-current circuit breaker.

Before connecting the hydraulic oil heater:

- *The machine must be in transport position, \triangleleft OPERATING THE MACHINE: TRANSPORT/WORKING POSITION.*
 - *The jib arm must be fully lowered.*
- *The hydraulic oil level must be checked, \triangleleft 3 - MAINTENANCE: DAILY MAINTENANCE.*
 - *The machine should be switched off.*

The hydraulic oil heater is designed to heat the hydraulic oil when the outside temperature is below -15 °C.

- Open the right-hand turntable cover.
- Locate the electrical plug ①.
- Connect it to a power source.
- Wait for the desired heating time and disconnect it.
- Close the right-hand turntable cover.

Note: the heating time depends on the ambient temperature and other factors.
Adjust the heating time, observing the conditions for machine operation.

Note: the illustration shows 2 plugs for the battery heater (option) and for the hydraulic oil heater (option) with the corresponding stickers ① and ②.



ENGINE BLOCK HEATER

⚠ IMPORTANT ⚠

Plug the engine block heater to a 230 V/50 Hz power source delivering 16 A protected by a 30 mA residual-current circuit breaker.

The machine should be switched off before connecting the engine block heater.

The engine block heater is designed to heat the engine block when the outside temperature is below -10 °C.

- Open the right-hand turntable cover.
- Locate the electrical plug **1**.
- Connect it to a power source.
- Wait for the desired heating time and disconnect it.
- Close the right-hand turntable cover.

Note: the heating time depends on the ambient temperature and other factors.
Adjust the heating time, observing the conditions for starting the diesel engine.



ELECTRIC GENERATOR

Note: the illustrations show a 260 TJ+ with a standard platform without gate.

The electric generator option includes:

- 1 electric generator ①, located under the right-hand turntable cover, with 1 30 mA residual-current circuit breaker.
- 1 electric generator button ② on the platform control panel.
- 110 V 3.5 kW electric generator option:
 - 1 electric power socket ③ in the platform supplying 110 V/50 Hz, 16 A maximum.
- 230 V 3.5 kW electric generator option:
 - 3 electric power sockets ④ in the platform supplying 230 V/50 Hz, 16 A maximum.
- 230 V 5 kW electric generator option:
 - 3 electric power sockets ④ in the platform supplying 230 V/50 Hz, 16 A maximum.

Note: ⚠ STICKERS: 110 V ELECTRICAL SYSTEM (OPTION) or ⚠ STICKERS: 230 V ELECTRICAL SYSTEM (OPTION).

INSTRUCTIONS: ELECTRIC POWER SOCKET IN THE PLATFORM

⚠ IMPORTANT ⚠

Only connect electrical appliances that work with:

- 110 V/50 Hz, 16 A maximum (110 V 3.5 kW electric generator option).

- 230 V/50 Hz, 16 A maximum (230 V 3.5 kW electric generator option and 230 V 5 kW electric generator option).

*Do not connect extension cords, power supply bars or plugs with multiple sockets to the electric power socket(s).
The electric generator is automatically stopped when any machine function is activated. It automatically restarts when the machine's functions are no longer activated.*

Overvoltages could occur when the electric generator is started. Make sure that the electrical equipment is powered down before:

- Starting the electric generator.

- Activating the machine's functions when the electric generator is started.

Note: the diesel engine must be started.

- Press and release the electric generator button ② to start the electric generator.
- 110 V 3.5 kW electric generator option:
 - Plug 1 electrical appliance into the power socket ③.
- 230 V 3.5 kW electric generator option and 230 V 5 kW electric generator option:
 - Plug 1, 2 or 3 electrical appliances into the power socket(s) ④.
- Power on the electrical appliances.
- Power down the electrical appliances when the work has been completed.
- Press and release the electric generator button to stop the electric generator.

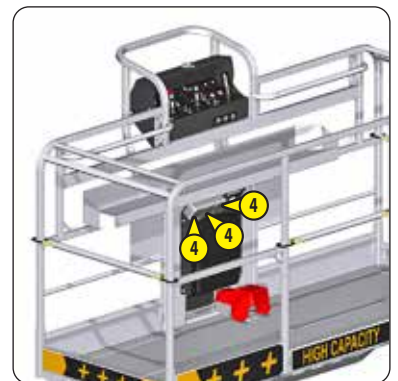
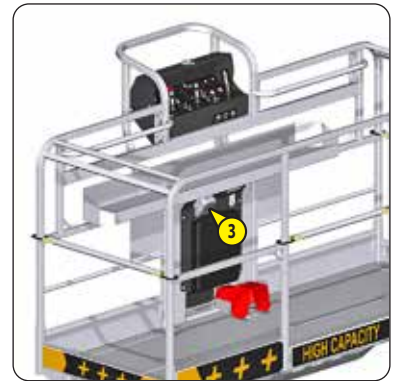
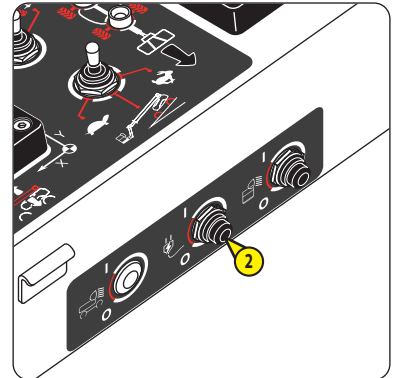

INSTRUCTIONS: RESIDUAL-CURRENT CIRCUIT BREAKER

To reset the residual-current circuit breaker:

- Power down the electrical appliance(s).
- Press and release the electric generator button **2** to stop the electric generator.
- Put the machine in transport position, OPERATING THE MACHINE: TRANSPORT/WORKING POSITION.
- Fully lower the jib arm.
- Open the right-hand turntable cover.
- Locate the switch **1A** on the electric generator **1**.
- Push it to the ON position.

Result:

- The switch must remain in the ON position, the indicator **1B** should be red.
- Press and release the electric generator button **2** to start the electric generator.
- Check that the switch **1A** remains in the ON position and that the indicator **1B** is red.
- Close the right-hand turntable cover.

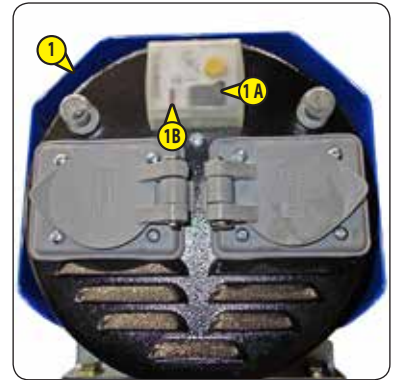
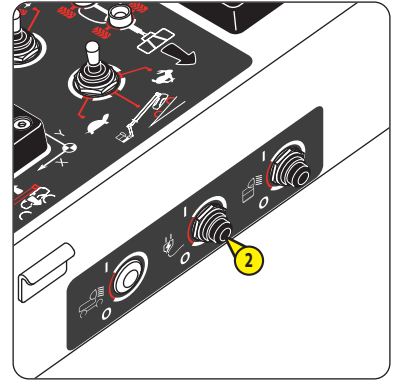

PLATFORM WORKLIGHT

Note: the illustration shows a 260 TJ+ standard platform without gate.

INSTRUCTIONS

Note: the machine should be turned on.

- Press and release the worklight button **2** to turn the worklight **1** on or off.

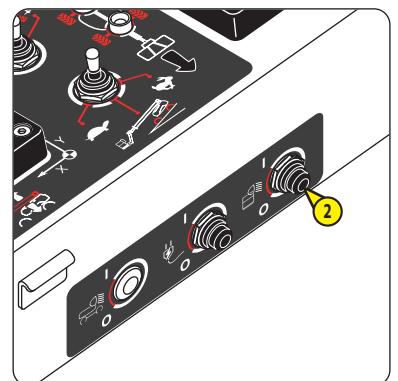
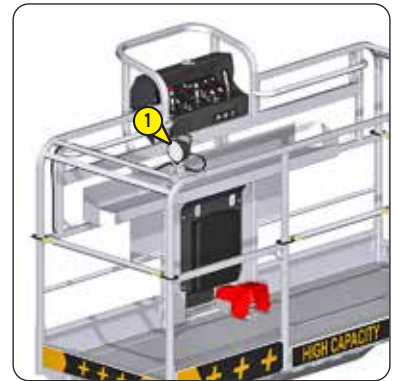

ADJUSTMENT

Use the handle **1A** to direct the worklight **1** left, right, up or down.

The worklight can be moved along the guardrails:

- Loosen the tightening wheel **1B**.
- Move the worklight.
- Do the tightening wheel back up.

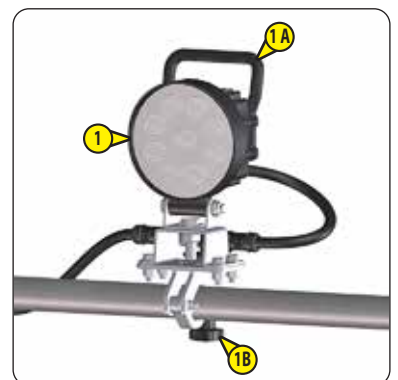

SECONDARY PROTECTION SYSTEM SPS

⚠ IMPORTANT ⚠

*Operate the machine's functions extremely carefully during attempts at clearance.
If the audible alarm sounds quickly and intermittently and the flashing light SPS ① flashes rapidly: the machine can be used but the secondary protection system SPS is deactivated, consult maintenance personnel.*

Note: the audible alarm sounds once and the flashing light SPS ① flashes several times when the machine is powered up. This indicates that the secondary protection system SPS is operating correctly.

Note: the flashing light SPS ① can be blue or red depending on the country.

SECONDARY PROTECTION SYSTEM SPS ALERT

It occurs when you are trapped between the safety cable SPS ② and a structure ④:

- All of the machine's functions are stopped and locked.
- An alert page is displayed on the ground level display screen.
- The horn sounds intermittently and the flashing light SPS ① flashes.

If you are still trapped between the safety cable SPS and the structure:

- Press and release the reset button SPS ③.

Result:

- The machine's functions are unlocked, use them to get free.
- The alert page will no longer be displayed when you are no longer trapped.
- The horn will stop sounding and the flashing light SPS goes out when you are no longer trapped.

If you are no longer trapped between the safety cable SPS and the structure:

- Press and release the reset button SPS ③.

Result:

- All of the machine's functions are unlocked.
- The alert page is no longer displayed.
- The horn stops and the flashing light SPS goes out.

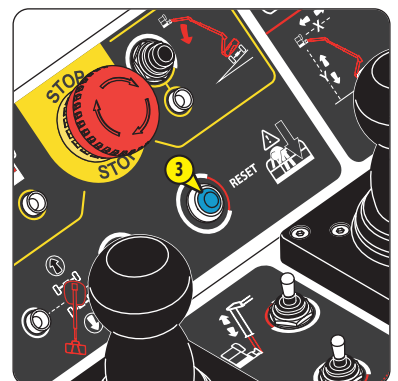
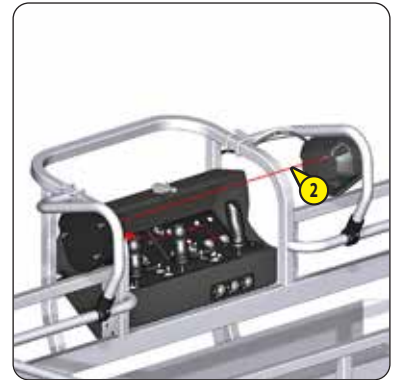
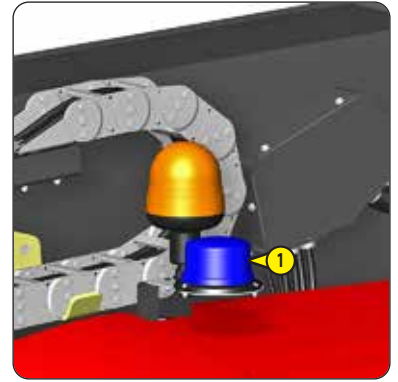

TRANSPORT AND LIFTING

TRANSPORT INSTRUCTIONS

⚠ IMPORTANT ⚠

Check that the safety instructions associated with the transport vehicle have been correctly applied before loading the machine and ensure that the driver of the vehicle has been informed of the dimensional characteristics and total weight of the machine.

Ensure that the transport vehicle has adequate dimensions and load capacity for transporting the machine, SPECIFICATIONS and STICKERS.

It is essential that the turntable is locked when the machine is being transported, SAFETY COMPONENTS: TURNTABLE LOCKING PIN.

Covers must be closed and locked (if applicable) while the machine is being transported.

LOADING/UNLOADING THE MACHINE

⚠ IMPORTANT ⚠

The transport vehicle must be parked on a level surface and the wheels must be chocked to prevent it from rolling during loading and unloading of the machine.

Automatic exhaust regeneration must be deactivated, OPERATING THE MACHINE: AUTOMATIC EXHAUST REGENERATION.

Turntable rotation is prohibited while the machine is being loaded onto the transport vehicle and during unloading.

The turntable must be locked before loading the machine onto the transport vehicle and before unloading it, SAFETY COMPONENTS: TURNTABLE LOCKING PIN.

The machine must be loaded or unloaded using a winch if the loading ramps are slippery, FREEWHEELING FOR WINCHING.

The angle of the loading ramps must not exceed the maximum slope accessible value, SPECIFICATIONS.

The machine must be loaded and unloaded using a crane if the angle of the loading ramps exceeds the maximum slope accessible value, TRANSPORT FOR WINCHING: LIFTING INSTRUCTIONS.

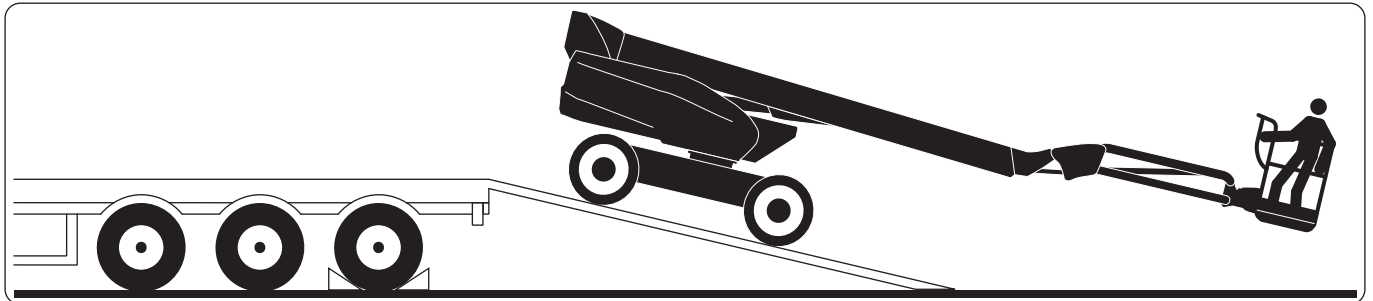

LOADING THE MACHINE ONTO THE TRANSPORT VEHICLE

- From the ground level control panel:
 - Start the diesel engine.
 - Deactivate automatic exhaust regeneration, OPERATING THE MACHINE: AUTOMATIC EXHAUST REGENERATION.
 - Put the platform in transport position; put the turntable in neutral position, OPERATING THE MACHINE: TRANSPORT/WORKING POSITION.
 - Fully lower the jib arm.
- Lock the turntable, SAFETY COMPONENTS: TURNTABLE LOCKING PIN.
- Get into the platform.
- Put the platform in neutral position, OPERATING THE MACHINE: TRANSPORT/WORKING POSITION.
- Raise the jib arm slightly to prevent the platform hitting the ground or the loading ramps.
- Select ramp speed .
- Drive the machine forward slowly with the platform at the bottom of the slope as shown in the illustration.

UNLOADING THE MACHINE FROM THE TRANSPORT VEHICLE

Note: the machine is in transport position **A**, CONFIGURING THE MACHINE FOR TRANSPORT 260 TJ+ below or CONFIGURING THE MACHINE FOR TRANSPORT 280 TJ on the next page.

- Ensure that the turntable is locked, SAFETY COMPONENTS: TURNTABLE LOCKING PIN.
- From the ground level control panel:
 - Start the diesel engine.
 - Deactivate automatic exhaust regeneration, OPERATING THE MACHINE: AUTOMATIC EXHAUST REGENERATION.
- Get into the platform.
- Raise the jib arm slightly to prevent the platform hitting the ground or the loading ramps.
- Select ramp speed .
- Reverse the machine slowly with the platform at the bottom of the slope as shown in the illustration on the previous page.

CONFIGURE THE MACHINE FOR TRANSPORT 260 TJ+

⚠ IMPORTANT ⚠

Automatic exhaust regeneration must be deactivated, OPERATING THE MACHINE: AUTOMATIC EXHAUST REGENERATION.

Turntable rotation is prohibited once on the transport vehicle.

The turntable must be locked once on the transport vehicle, SAFETY COMPONENTS: TURNTABLE LOCKING PIN.

*The machine must be transported in folded position **B**.*

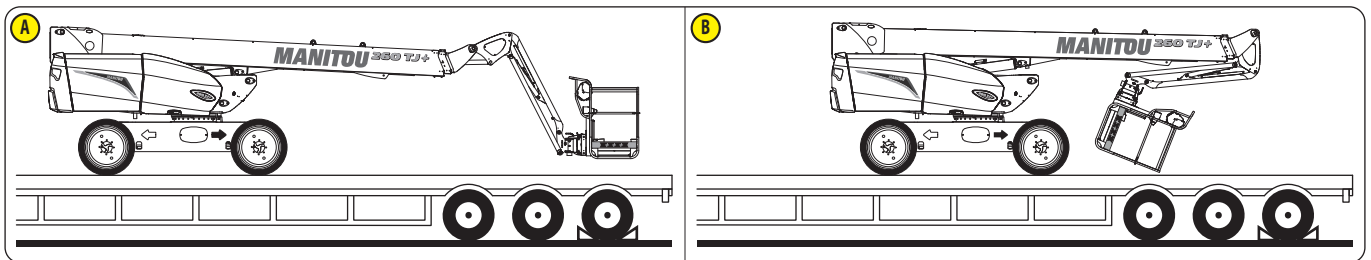

FOLDED POSITION **B**

Note: the diesel engine has been started. Automatic exhaust regeneration is deactivated. The machine is in transport position. The turntable and the platform are in neutral position. The turntable is locked.

- Fully lower the jib arm.
- Get out of the platform.
- From the ground level control panel or from the remote control unit:
 - Raise the main arm slightly.
 - Tilt the platform/jib arm down completely (1). Ensure that the platform cannot hit the transport vehicle.
 - Lower the main arm so that the platform is approximately 10 cm from the transport vehicle. The platform must not touch the transport vehicle.
 - Switch off the machine. Remove the key.

(1) This function can only be activated when the angle of the main arm is 15° maximum in relation to the fully lowered position.

Note: STICKERS: FOLDING/UNFOLDING THE MACHINE 260 TJ+.

MOVING FROM THE FOLDED POSITION **B** TO THE TRANSPORT POSITION **A**

Note: the turntable is locked.

- From the ground level control panel:
 - Start the diesel engine.
 - Deactivate automatic exhaust regeneration, \triangleleft OPERATING THE MACHINE: AUTOMATIC EXHAUST REGENERATION.
- From the ground level control panel or from the remote control unit:
 - Raise the main arm slightly.
 - Tilt the platform/jib arm up (1) until the platform floor is horizontal. Ensure that the platform cannot hit the transport vehicle.
 - Fully lower the main arm.

(1) This function can only be activated when the angle of the main arm is 15° maximum in relation to the fully lowered position.

- Switch off the machine.

Note: \triangleleft STICKERS: FOLDING/UNFOLDING THE MACHINE 260 TJ+.

CONFIGURE THE MACHINE FOR TRANSPORT 280 TJ

⚠ IMPORTANT ⚠

Automatic exhaust regeneration must be deactivated, \triangleleft OPERATING THE MACHINE: AUTOMATIC EXHAUST REGENERATION.

Turntable rotation is prohibited once on the transport vehicle.

The turntable must be locked once on the transport vehicle, \triangleleft SAFETY COMPONENTS: TURNTABLE LOCKING PIN.

*The machine must be transported in folded position **B**.*

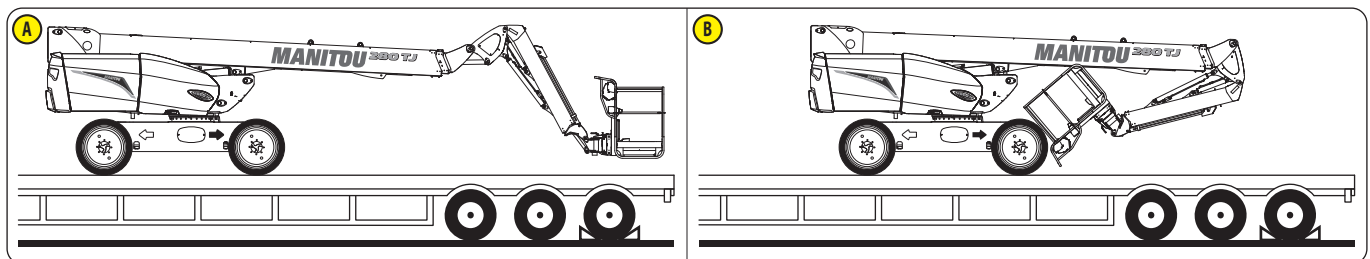

FOLDED POSITION **B**

Note: the diesel engine has been started. Automatic exhaust regeneration is deactivated. The machine is in transport position. The turntable and the platform are in neutral position. The turntable is locked.

- Fully lower the jib arm.
- Get out of the platform.
- From the remote control unit:
 - Raise the main arm slightly.
 - Tilt the platform down completely (1). Ensure that the platform cannot hit the transport vehicle.
 - Tilt the platform/jib arm down (2) to place the platform near the main arm. Ensure that the platform cannot hit the transport vehicle.
 - Lower the main arm so that the platform is approximately 10 cm from the transport vehicle. The platform must not touch the transport vehicle or the rear wheels of the machine.
 - Switch off the machine. Remove the key.

(1) This function can only be activated when the platform/jib arm tilt is less than 5° (up or down).

(2) This function can only be activated when the angle of the main arm is 15° maximum in relation to the fully lowered position.

Note: \triangleleft STICKERS: FOLDING/UNFOLDING THE MACHINE 280 TJ.

MOVE FROM THE FOLDED POSITION **B** TO THE TRANSPORT POSITION **A**

Note: the turntable is locked.

- From the ground level control panel:
 - Start the diesel engine.
 - Deactivate automatic exhaust regeneration,  OPERATING THE MACHINE: AUTOMATIC EXHAUST REGENERATION.
- From the remote control unit:
 - Raise the main arm slightly.
 - Tilt the platform/jib arm up (1) until the gage **C** reaches the 0° mark on the sticker **D** PLATFORM/JIB ARM TILT. Ensure that the platform cannot hit the transport vehicle.
 - Tilt the platform up until the platform floor is horizontal. Ensure that the platform cannot hit the transport vehicle.
 - Fully lower the main arm.

(1) This function can only be activated when the angle of the main arm is 15° maximum in relation to the fully lowered position.

- Switch off the machine.

Note:  STICKERS: FOLDING/UNFOLDING THE MACHINE 280 TJ.

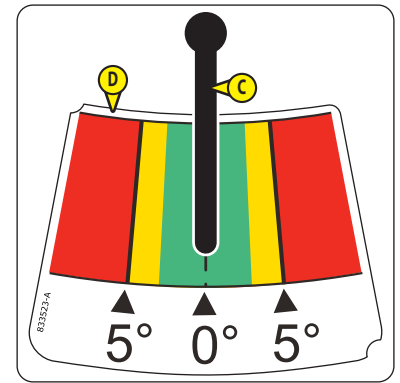

⚠ IMPORTANT ⚠

Turntable rotation is prohibited once on the transport vehicle.

The turntable must be locked once on the transport vehicle, ⚠ SAFETY COMPONENTS: TURNABLE LOCKING PIN.

The machine is equipped with 8 anchoring points (⚠ STICKERS: ANCHORING POINT); comply with local, governmental and national regulations in force concerning the minimum number of anchoring points required when transporting a machine.

Make sure that the chains and/or straps are not in contact with the wheels and the machine is correctly anchored to the transport vehicle.

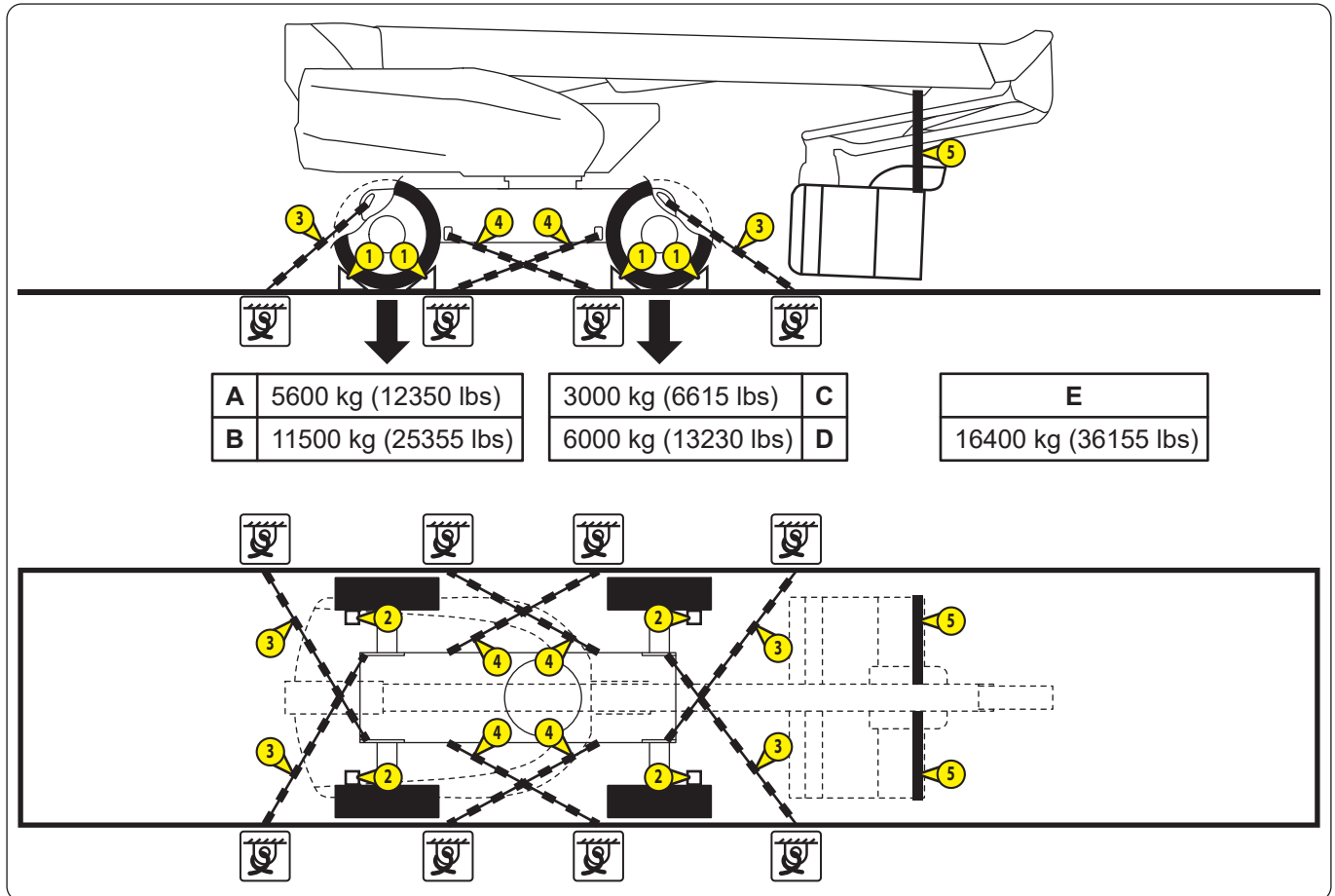

KEY:

A	C	"LOAD ON 1 WHEEL"	LOAD ON 1 WHEEL
B	D	"LOAD ON 2 WHEELS"	LOAD ON 2 WHEELS
E		"TOTAL MASS"	TOTAL WEIGHT

Note: the machine is powered down. The machine is in folded position (B), ⚠ CONFIGURING THE MACHINE FOR TRANSPORT 260 TJ+. The turntable is locked.

- Fix chocks (1) to the transport vehicle at the front and rear of each of the machine's wheels.
- Fix chocks (2) to the transport vehicle on the inner side of each of the machine's wheels.
- Secure the machine to the transport vehicle with sufficiently robust straps or chains (3) and/or (4) (according to the regulations in force) attached to the machine's anchoring points, ⚠ STICKERS: ANCHORING POINT.
- Attach the platform to the main arm with the 2 straps (5) supplied with the machine. Do not overtighten to avoid damage. The platform must not touch the transport vehicle.

Note: ⚠ STICKERS: ANCHORING 260 TJ+.

⚠ IMPORTANT ⚠

Turntable rotation is prohibited once on the transport vehicle.

The turntable must be locked once on the transport vehicle, ⚠ SAFETY COMPONENTS: TURNTABLE LOCKING PIN.

The machine is equipped with 8 anchoring points (⚠ STICKERS: ANCHORING POINT); comply with local, governmental and national regulations in force concerning the minimum number of anchoring points required when transporting a machine.

Make sure that the chains and/or straps are not in contact with the wheels and the machine is correctly anchored to the transport vehicle.

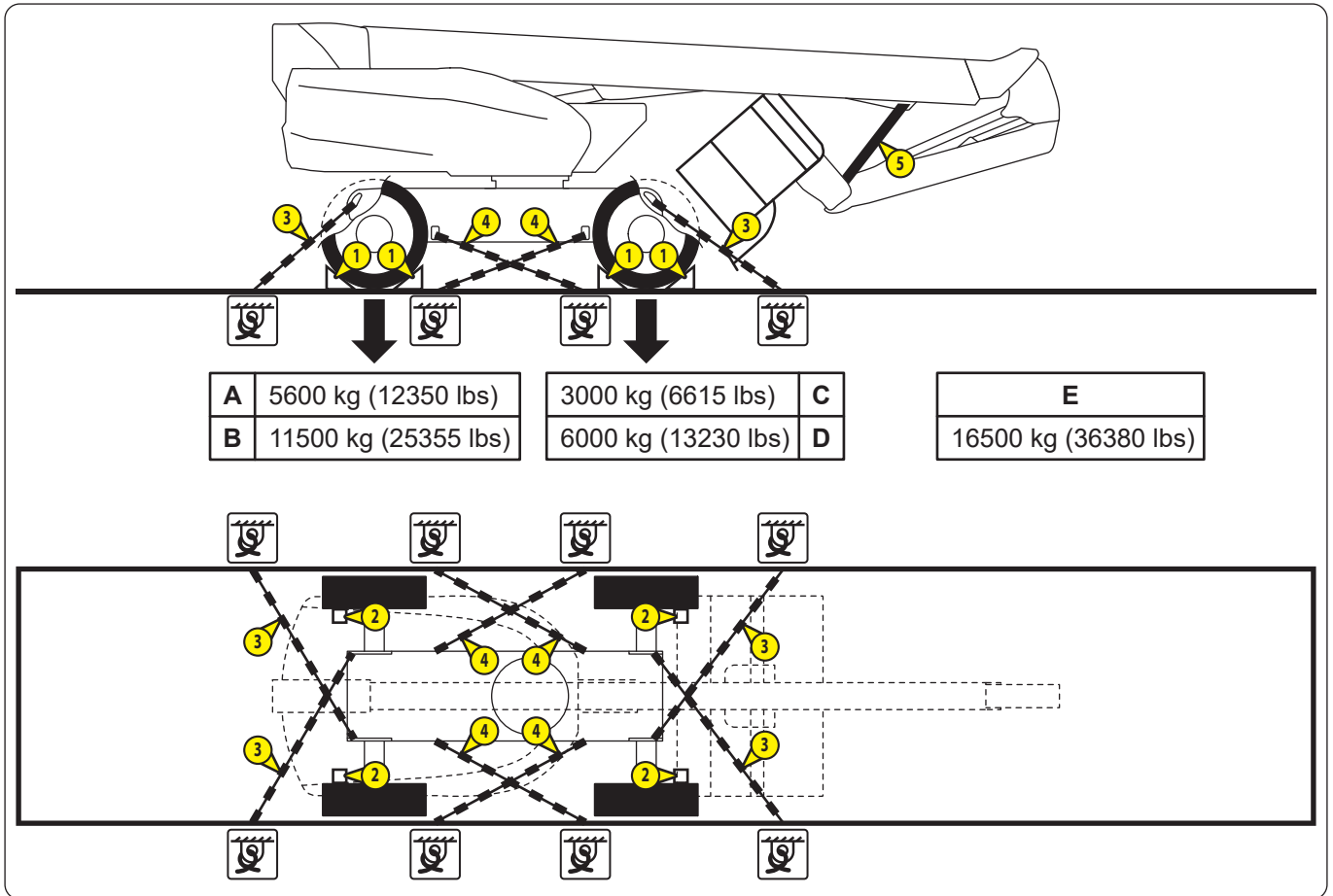

KEY:

A	C	"LOAD ON 1 WHEEL" LOAD ON 1 WHEEL
B	D	"LOAD ON 2 WHEELS" LOAD ON 2 WHEELS
E		"TOTAL MASS" TOTAL WEIGHT

Note: the machine is powered down. The machine is in folded position (B), ⚠ CONFIGURING THE MACHINE FOR TRANSPORT 280 TJ. The turntable is locked.

- Fix chocks (1) to the transport vehicle at the front and rear of each of the machine's wheels.
- Fix chocks (2) to the transport vehicle on the inner side of each of the machine's wheels.
- Secure the machine to the transport vehicle with sufficiently robust straps or chains (3) and/or (4) (according to the regulations in force) attached to the machine's anchoring points, ⚠ STICKERS: ANCHORING POINT.
- Attach the jib arm to the main arm with the strap (5) supplied with the machine. Do not overtighten to avoid damage. The platform must not touch the transport vehicle or the rear wheels of the machine.

Note: ⚠ STICKERS: ANCHORING 280 TJ.

FREEWHEEL FOR WINCHING

⚠ IMPORTANT ⚠

Towing of the machine is prohibited.

The machine must be winched in transport position. Winching the machine in working position is prohibited, ⚠ OPERATING THE MACHINE: TRANSPORT/WORKING POSITION.

Always use a suitable winch for winching the machine.

Before releasing the brakes:

- The machine must be on a level surface.

- The wheels must be chocked.

The platform must be empty when the machine is being winched:

FREEWHEEL AND WINCH

- Switch off the machine.
- Attach the winch to the machine's anchoring points, ⚠ STICKERS: ANCHORING POINT.
- Bypass the hydrostatic circuit:
 - Open the left-hand turntable cover.
 - Locate the hydrostatic pump and the 2 pressure relief valves ①.
 - Unscrew the nuts ①A. Tighten the screws ①B to the hard spot and then tighten them a half turn more.
 - Tighten the nuts ①A: tightening torque = 22 N.m
 - Close the left-hand turntable cover.
- Release the rear axle brakes:
 - Locate the 2 screws ② and the 2 screws ③ to the left and right of the rear axle.
 - Loosen the 2 locknuts ④ by about 8 mm.
 - Tighten the screws ② and ③ by hand to the hard spot.
 - Tighten the 2 screws alternately ② by a quarter turn each time until you have gone all the way round.
 - Tighten the 2 screws alternately ③ by a quarter turn each time until you have gone all the way round.
- Release the front axle brakes:
 - Follow the same procedure as for the rear axle.
- Make sure the route is free of any obstruction.
- Remove the chocks from the wheels.
- Winch the machine slowly.
- Chock the wheels when the machine is in the desired position.

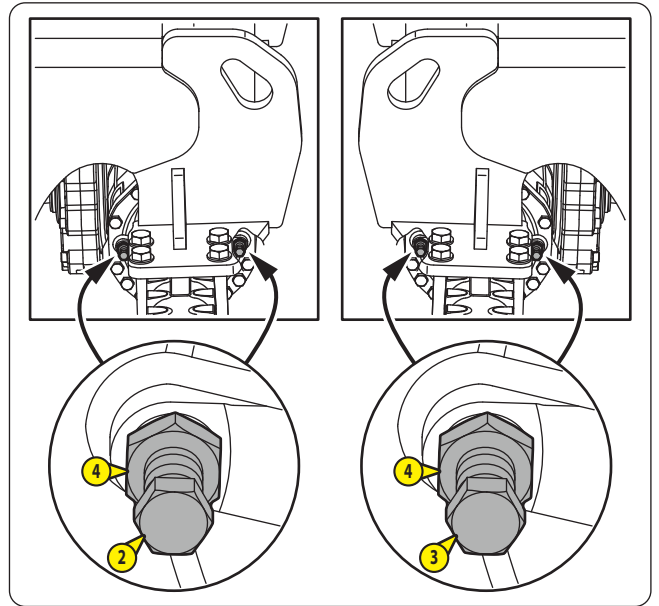
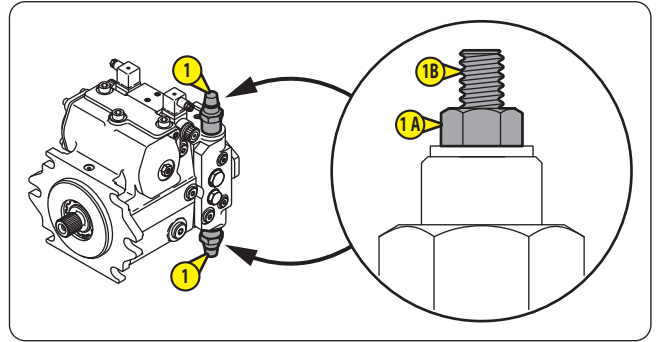

REAPPLY THE BRAKES AND RESTORE THE HYDROSTATIC CIRCUIT

- Reapply the rear axle brakes:
 - Loosen the 2 screws alternately (2) by a quarter turn each time until you have gone all the way round.
 - Loosen the 2 screws alternately (3) by a quarter turn each time until you have gone all the way round.
 - Unscrew the 4 screws (2) and (3) completely.
 - Change the 4 seals (5).
 - Lubricate the screws (2) and (3) with MANITOU BLACK MULTI-PURPOSE LUBRICANT (← 3 - MAINTENANCE: LUBRICANTS, COOLANT AND FUEL) and refit them.
 - Adjust the distance between the body of the axle and the screw heads = 34 mm ±0.5 mm.
 - Tighten the 4 locknuts (4) and check the distances between the body of the axle and the screw heads.
- Reapply the front axle brakes:
 - Follow the same procedure as for the rear axle.
- Restore the hydrostatic circuit:
 - Open the left-hand turntable cover.
 - Unscrew the nuts (1A).
 - Loosen the screws (1B) up to the mechanical stop.
 - Tighten the nuts (1A): tightening torque = 22 N.m
 - Close the left-hand turntable cover.

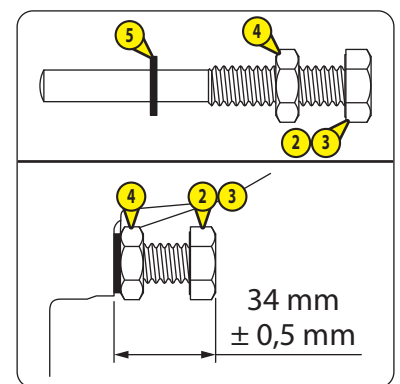
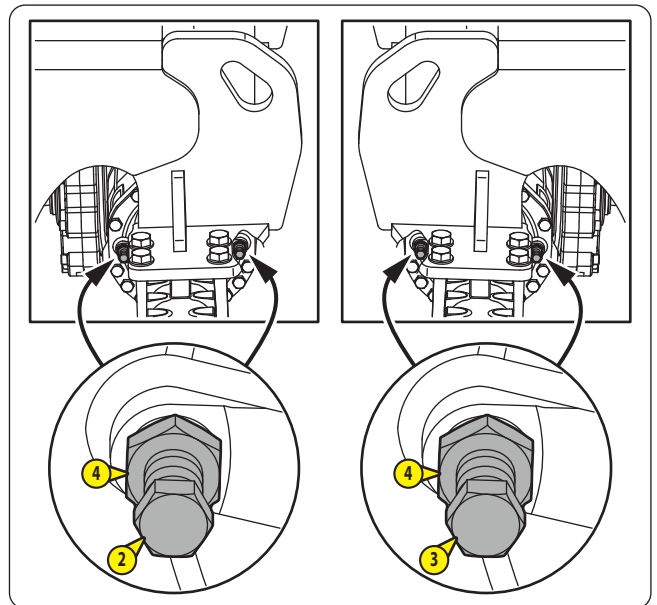

TEST THE BRAKES

- Remove the right-hand chassis cover.
- Locate the coil "EV100" on the hydraulic block (6) and disconnect it, refer to the sticker (A) CHASSIS HYDRAULIC BLOCK COILS.
- Start the diesel engine.
- Try to drive the machine forward and backward.

Result:

- The machine should remain stationary.
- Reconnect the coil "EV100".
- Refit the right-hand chassis cover.
- Switch off the machine.

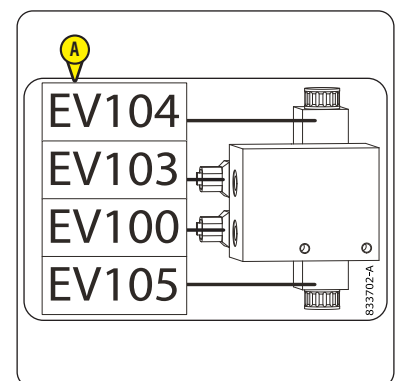
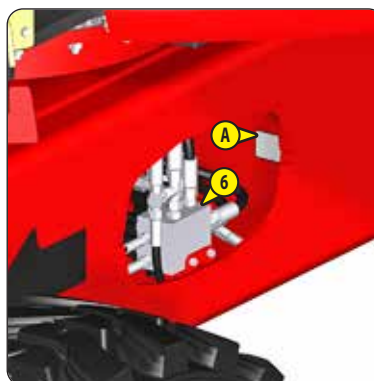
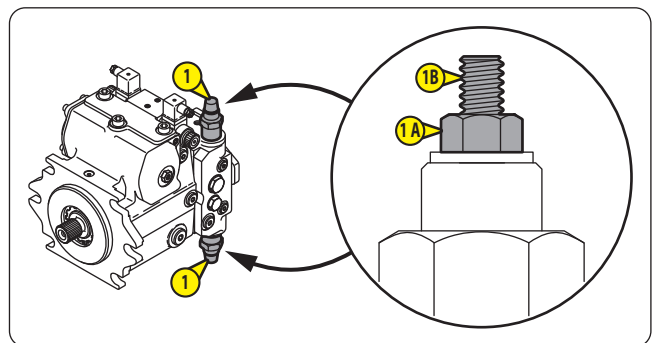

⚠ IMPORTANT ⚠

The surface of the departure/arrival zone must be closed, level and even.

If the departure/arrival zone is a transport vehicle:

- The transport vehicle must be parked on a level, firm surface.
- The wheels of the transport vehicle must be chocked.

Make sure that the lifting slings are solid enough to take the weight of the machine.

Make sure that the lifting capacity of the crane is sufficient to take the weight of the machine.

Automatic exhaust regeneration must be deactivated, ⚠ OPERATING THE MACHINE: AUTOMATIC EXHAUST REGENERATION.

It is essential that the turntable is locked before lifting the machine, ⚠ SAFETY COMPONENTS: TURNTABLE LOCKING PIN.

Covers must be closed and locked (if applicable) while the machine is being lifted.

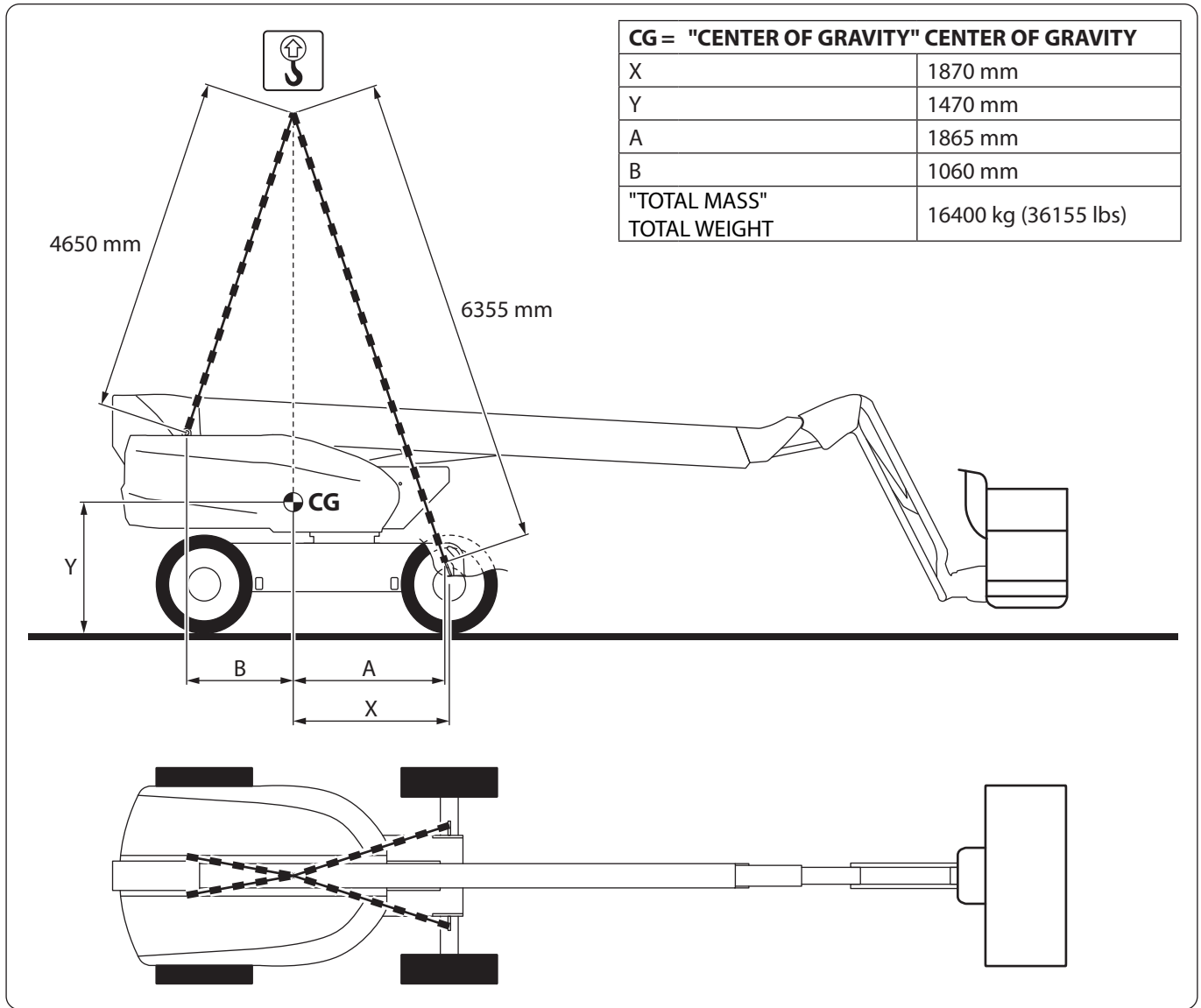

- Mark out a wide safety area around the machine.
- Start the diesel engine.
- Deactivate automatic exhaust regeneration, OPERATING THE MACHINE: AUTOMATIC EXHAUST REGENERATION.
- Put the machine in transport position. Put the platform in neutral position, OPERATING THE MACHINE: TRANSPORT/WORKING POSITION.
- Fully lower the jib arm.
- Ensure that the turntable is locked, SAFETY COMPONENTS: TURNTABLE LOCKING PIN.
- Switch off the machine. Remove the key.
- Attach lifting slings to the 4 lifting points on the machine, STICKERS: LIFTING POINT.
- Attach the lifting slings at 1 point to the crane lifting hook.
- Slowly lift the crane's lifting hook until the lifting slings are slightly taut.
- If necessary, adjust the lifting slings to prevent damage and keep the machine level.
- Ensure that there is nobody in the safety zone.
- Lift the machine slowly and move it to the arrival zone.
- Slowly lower the machine until the 4 wheels are in contact with the receiving surface.
- Lower the crane's lifting hook until the lifting slings are no longer taut.
- Detach the lifting slings.

Note: STICKERS: LIFTING 260 TJ+.

⚠ IMPORTANT ⚠

The surface of the departure/arrival zone must be closed, level and even.

If the departure/arrival zone is a transport vehicle:

- The transport vehicle must be parked on a level, firm surface.
- The wheels of the transport vehicle must be chocked.

Make sure that the lifting slings are solid enough to take the weight of the machine.

Make sure that the lifting capacity of the crane is sufficient to take the weight of the machine.

Automatic exhaust regeneration must be deactivated, ⚠ OPERATING THE MACHINE: AUTOMATIC EXHAUST REGENERATION.

It is essential that the turntable is locked before lifting the machine, ⚠ SAFETY COMPONENTS: TURNTABLE LOCKING PIN.

Covers must be closed and locked (if applicable) while the machine is being lifted.

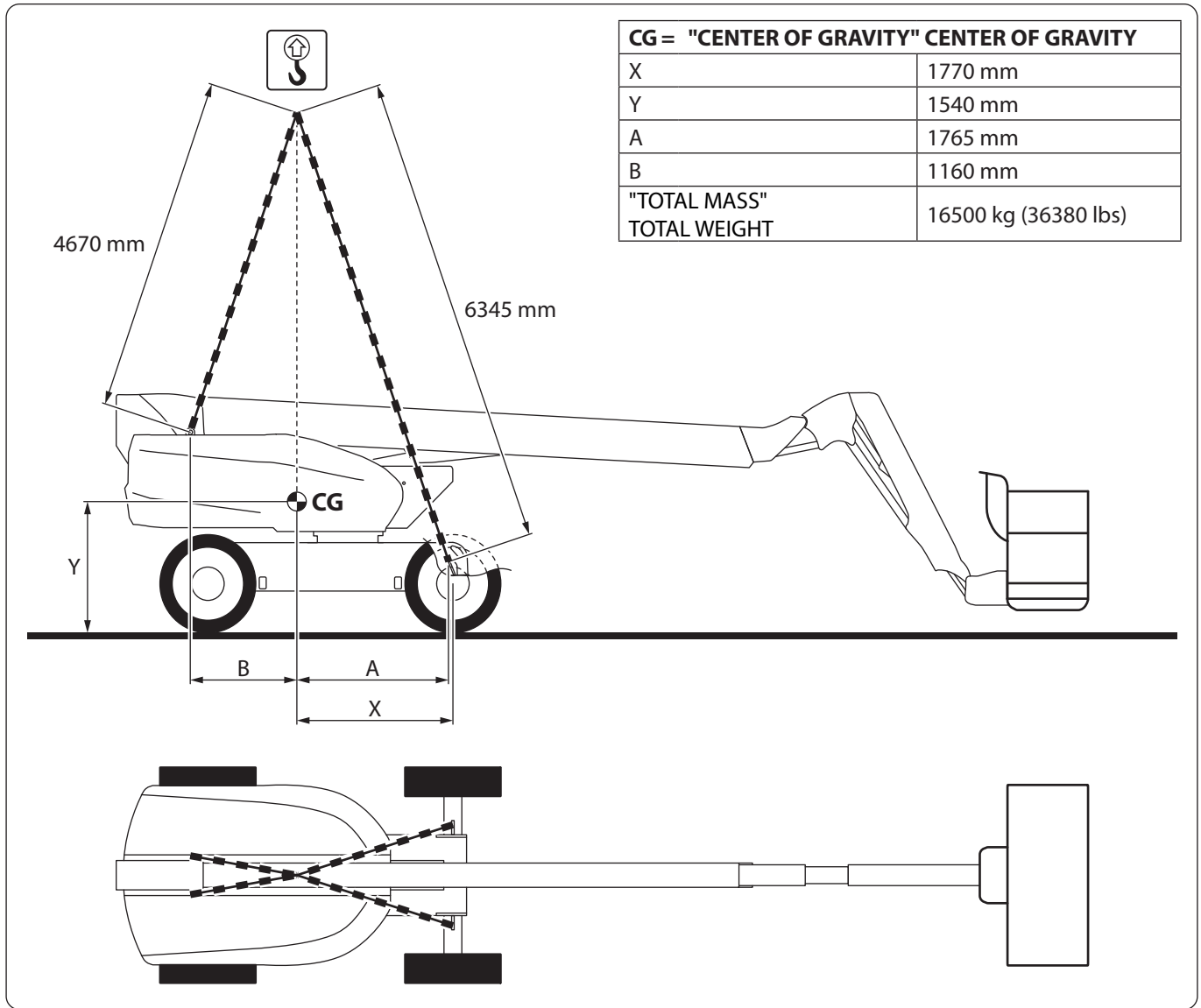

- Mark out a wide safety area around the machine.
- Start the diesel engine.
- Deactivate automatic exhaust regeneration, OPERATING THE MACHINE: AUTOMATIC EXHAUST REGENERATION.
- Put the machine in transport position. Put the platform in neutral position, OPERATING THE MACHINE: TRANSPORT/WORKING POSITION.
- Fully lower the jib arm.
- Ensure that the turntable is locked, SAFETY COMPONENTS: TURNTABLE LOCKING PIN.
- Switch off the machine. Remove the key.
- Attach lifting slings to the 4 lifting points on the machine, STICKERS: LIFTING POINT.
- Attach the lifting slings at 1 point to the crane lifting hook.
- Slowly lift the crane's lifting hook until the lifting slings are slightly taut.
- If necessary, adjust the lifting slings to prevent damage and keep the machine level.
- Ensure that there is nobody in the safety zone.
- Lift the machine slowly and move it to the arrival zone.
- Slowly lower the machine until the 4 wheels are in contact with the receiving surface.
- Lower the crane's lifting hook until the lifting slings are no longer taut.
- Detach the lifting slings.

Note: STICKERS: LIFTING 280 TJ.

3 - MAINTENANCE

3 - MAINTENANCE

INTRODUCTION	3-4
ORIGINAL MANITOU SPARE PARTS AND EQUIPMENT	3-4
DAILY AND MONTHLY MAINTENANCE	3-5
MANDATORY SERVICING AND PERIODIC MAINTENANCE	3-6
OCCASIONAL MAINTENANCE AND OCCASIONAL OPERATIONS	3-10
FILTER CARTRIDGES AND BELTS	3-11
LUBRICANTS, COOLANT AND FUEL	3-12
➤ DAILY MAINTENANCE	3-14
➤ MONTHLY MAINTENANCE OR EVERY 50 HOURS OF SERVICE	3-31
➤ ➊ 250H - PERIODIC MAINTENANCE - EVERY 250 HOURS OF SERVICE OR 6 MONTHS	3-38
➤ ➋ 500H - PERIODIC MAINTENANCE - EVERY 500 HOURS OF SERVICE OR 1 YEAR	3-54
➤ ➌ 1000H - PERIODIC MAINTENANCE - EVERY 1000 HOURS OF SERVICE OR 2 YEARS	3-66
➤ ➍ 1500H - PERIODIC MAINTENANCE - EVERY 1500 HOURS OF SERVICE OR 3 YEARS	3-72
➤ ➎ 2000H - PERIODIC MAINTENANCE - EVERY 2000 HOURS OF SERVICE OR 4 YEARS	3-72
➤ ➏ 3000H - PERIODIC MAINTENANCE - EVERY 3000 HOURS OF SERVICE OR 6 YEARS	3-72
➤ ➐ 6000H - PERIODIC MAINTENANCE - EVERY 6000 HOURS OF SERVICE OR 12 YEARS	3-72
➤ OCCASIONAL MAINTENANCE	3-73
➤ OCCASIONAL OPERATIONS	3-77

INTRODUCTION

MAINTENANCE OPERATIONS REQUIRE SPECIFIC PRECAUTIONS.

⚠ IMPORTANT ⚠

In order to maintain the machine's connectivity, some electrical components remain live even when the battery cut-off (option) is in the OFF position.

Unless specific instructions are given, during maintenance operations:

- *The machine should be switched off.*
- *The machine must be on a level surface. The wheels must be chocked.*
- *The machine should be in transport position. The turntable and the platform should be in neutral position, 2 - DESCRIPTION: OPERATING THE MACHINE: TRANSPORT/WORKING POSITION.*
- *The jib arm must be fully lowered.*
- *The platform must be empty.*
- *The turntable must be unlocked, 2 - DESCRIPTION: SAFETY COMPONENTS: TURNABLE LOCKING PIN.*
 - *If installed, the pipe support must be empty.*
 - *If installed, the panel support must be empty.*

ORIGINAL MANITOU SPARE PARTS AND EQUIPMENT

OUR MACHINES MUST BE SERVICED USING ORIGINAL MANITOU PARTS.

BY ALLOWING THE USE OF NON ORIGINAL MANITOU PARTS, YOU RISK:

⚠ IMPORTANT ⚠

THE USE OF COUNTERFEIT PARTS OR COMPONENTS NOT APPROVED BY THE MANUFACTURER MEANS YOU LOSE THE BENEFIT OF THE CONTRACTUAL GUARANTEE.

- Legally, incurring liability in the event of an accident.
- Technically, causing operating malfunctions and reducing the machine's service life.

BY USING ORIGINAL MANITOU PARTS FOR MAINTENANCE OPERATIONS, YOU BENEFIT FROM OUR KNOW-HOW

Through its network, MANITOU provides the user with:

- Know-how and competence.
- The guarantee of high-quality work.
- Original replacement parts.
- Help with preventive maintenance.
- Efficient help with diagnosis.
- Improvements as a result of feedback.
- Operator training.
- Only the MANITOU network has detailed knowledge of the design of the machine and therefore the best technical ability to provide maintenance.

⚠ IMPORTANT ⚠

ORIGINAL REPLACEMENT PARTS ARE DISTRIBUTED EXCLUSIVELY BY MANITOU AND ITS DEALER NETWORK.

The dealer network list is available on the MANITOU web site: www.manitou.com

DAILY AND MONTHLY MAINTENANCE

⚠ IMPORTANT ⚠

**DAILY MAINTENANCE MUST BE CARRIED OUT BY THE OPERATOR BEFORE USING THE MACHINE.
MONTHLY MAINTENANCE MUST BE CARRIED OUT BY THE MAINTENANCE PERSONNEL.**

🔄 DAILY MAINTENANCE

- CHECK	General inspection	3-14
- CHECK	Fuel level	3-14
- CHECK	Diesel engine oil level	3-15
- CHECK	Coolant level	3-15
- CHECK	Water separator	3-16
- CHECK	Hydraulic oil level	3-16
- CHECK	Machine operation	3-17

🔄 MONTHLY MAINTENANCE OR EVERY 50 HOURS OF SERVICE

ALSO PERFORM THE DAILY MAINTENANCE.

- CHECK	Injection pipes, fuel hoses and the hose clamps	3-31
- CHECK	Reduction gearbox seals	3-31
- CHECK	Front and rear axle differential seals	3-31
- CHECK	Front and rear wheel reduction gear seals	3-32
- CHECK	Remote control unit	3-32
- CLEAN	Coolant and oil radiators	3-33
- CLEAN	Outside air filter cartridge	3-33
- LUBRICATE	Axles	3-34
- BLEED	Water separator	3-35
- CHECK	230 V electric power socket in the platform (OPTION)	3-36
- CHECK	Generator (OPTION)	3-37
- CHECK	Condition of pipe support (ATTACHMENT)	3-37
- CHECK	Condition of panel support (ATTACHMENT)	3-37

MANDATORY SERVICING AND PERIODIC MAINTENANCE

⚠ IMPORTANT ⚠

THE MANDATORY SERVICE AND THE PERIODIC MAINTENANCE MUST BE CARRIED OUT BY AN APPROVED PROFESSIONAL FROM THE MANITOU NETWORK.

MAINTENANCE SCHEDULE

This schedule enables mandatory servicing and periodic maintenance on the machine to be kept up-to-date by reporting the total number of hours worked and the date of the service.

	⬇	⬇	OR	⬇
SCHEDULE ➡	FIRST 50 HOURS	FIRST 6 MONTHS		FIRST 500 HOURS
MANDATORY SERVICE ➡	FIRST 50 HOURS	FIRST 500 HOURS OR 6 MONTHS		FIRST 500 HOURS OR 6 MONTHS + 2
MACHINE COUNTER ➡				
DATE OF SERVICING ➡				

SCHEDULE ➡	250 H	500 H or 1 YEAR	750 H	1000 H or 2 YEARS	1250 H
PERIODIC MAINTENANCE ➡	1	1 + 2	1	1 + 2 + 3	1
MACHINE COUNTER ➡					
DATE OF SERVICING ➡					

SCHEDULE ➡	1500 H or 3 YEARS	1750 H	2000 H or 4 YEARS	2250 H	2500 H or 5 YEARS
PERIODIC MAINTENANCE ➡	1 + 2 + 4	1	1 + 2 + 3 + 5	1	1 + 2
MACHINE COUNTER ➡					
DATE OF SERVICING ➡					

SCHEDULE ➡	2750 H	3000 H or 6 YEARS	3250 H	3500 H or 7 YEARS	3750 H
PERIODIC MAINTENANCE ➡	1	1 + 2 + 3 + 4 + 6	1	1 + 2	1
MACHINE COUNTER ➡					
DATE OF SERVICING ➡					

SCHEDULE ➡	4000 H or 8 YEARS	4250 H	4500 H or 9 YEARS	4750 H	5000 H or 10 YEARS
PERIODIC MAINTENANCE ➡	1 + 2 + 3 + 5	1	1 + 2 + 4	1	1 + 2 + 3
MACHINE COUNTER ➡					
DATE OF SERVICING ➡					

SCHEDULE ➡	5250 H	5500 H or 11 YEARS	5750 H	6000 H or 12 YEARS
PERIODIC MAINTENANCE ➡	1	1 + 2	1	1 + 2 + 3 + 4 + 5 + 6 + 7
MACHINE COUNTER ➡				
DATE OF SERVICING ➡				

MANDATORY SERVICE - FIRST 50 HOURS

ALSO PERFORM THE MONTHLY MAINTENANCE.



This service must be carried out in the first 50 hours of service.

- CHECK	Alternator/fan belt	3-39
- CHECK	Wheel nut tightening	3-40
- CHECK	Tightening of the fixing screws for the oscillating cylinders	3-40
- CHECK	Tightening of the fixing screws for the axles	3-41
- CHECK	Tightening of the platform fixing screws	3-54
- CHECK	Tightening of the platform rotation cylinder fixing screws	3-55

MANDATORY SERVICE - FIRST 500 HOURS OR 6 MONTHS

This service must be carried out in the first 500 hours of service or within the 6 months following the start-up of the machine (whichever occurs first):

FIRST 500 HOURS BEFORE THE FIRST 6 MONTHS

- If the machine has reached the first 500 hours of service before the first 6 months have expired, perform both the compulsory service and periodic 500-hour maintenance (  500H - PERIODIC MAINTENANCE - EVERY 500 HOURS OF SERVICE OR 1 YEAR).

FIRST 6 MONTHS BEFORE THE FIRST 500 HOURS

- If the machine has not completed 500 hours of service in the first 6 months, carry out only the mandatory service.

- CHECK	General inspection	3-14
- CHECK	Machine operation	3-17
- CHECK	Injection pipes, fuel hoses and the hose clamps	3-31
- CHECK	Reduction gearbox seals	3-31
- CHECK	Front and rear axle differential seals	3-31
- CHECK	Front and rear wheel reduction gear seals	3-32
- CHECK	Remote control unit	3-32
- CLEAN	Coolant and oil radiators	3-33
- CLEAN	Outside air filter cartridge	3-33
- LUBRICATE	Axles	3-34
- BLEED	Water separator	3-35
- CHECK	230 V electric power socket in the platform (OPTION)	3-36
- CHECK	Generator (OPTION)	3-37
- CHECK	Condition of pipe support (ATTACHMENT)	3-37
- CHECK	Condition of panel support (ATTACHMENT)	3-37
- CHECK	Alternator/fan belt	3-39
- CHECK	Wheel nut tightening	3-40
- CHECK	Tightening of the fixing screws for the oscillating cylinders	3-40
- CHECK	Tightening of the transmission shaft fixing screws	3-40
- CHECK	Tightening of the fixing screws for the axles	3-41
- CHECK	Locking of the front axle oscillating cylinders	3-42
- CHECK	Overload system 260 TJ+	3-43
- CHECK	Overload system 280 TJ	3-44
- CHECK	Brakes	3-46
- CHECK	Turntable rotation motor oil level	3-47
- CHECK	Emergency controls	3-47
- CHECK	Tightening of 12 V electrical connections	3-48
- LUBRICATE	Shafts, hubs and cylinder rings 260 TJ+	3-49
- LUBRICATE	Shafts, hubs and cylinder rings 280 TJ	3-50
- GREASE	Telescopic arm	3-51
- GREASE	Telescopic jib arm 280 TJ	3-51
- LUBRICATE	Crown gear	3-52
- BLEED	Fuel tank	3-53
- CHECK	Tilt sensor	3-54
- CHECK	Tightening of the platform fixing screws	3-54
- CHECK	Tightening of the platform rotation cylinder fixing screws	3-55
- CHECK	Chocking of the telescopic jib arm 280 TJ	3-56

- CHECK	Chocking of telescopic arm.....	3-57
- CHECK	Tightening of the fixing screws on the telescopic arm cylinder.....	3-58
- CHECK	Tightening of the fixing screws for the crown gear.....	3-58
- CHECK	Tightening of the fixing screws on the turntable rotation motor.....	3-59
- CHECK	Tightening of cast iron counterweight fixing screws.....	3-59
- CHECK	Tightening of concrete counterweight fixing screws.....	3-59
- CHECK	Tightening of the fixing screws for the lifting points.....	3-60
- CHECK	Hydraulic hoses.....	3-60
- CHECK	Diesel engine silent blocks *.....	3-71
- CHECK	Diesel engine speeds *.....	3-71
- CHECK	Hydrostatic transmission circuit pressure *.....	3-71
- CHECK	Clearance of slewing ring gear *.....	3-71
- CHECK	Condition of the telescopic arm cables *.....	3-71
- CHECK	Speeds of hydraulic movements *.....	3-71
- CHECK	Condition of cylinders *.....	3-71
- CHECK	Condition of electric wiring *.....	3-71

** Consult your dealer.*

➔ 1 250H - PERIODIC MAINTENANCE - EVERY 250 HOURS OF SERVICE OR 6 MONTHS

ALSO PERFORM THE DAILY MAINTENANCE.

- CHECK	Injection pipes, fuel hoses and the hose clamps.....	3-38
- CHECK	Reduction gearbox seals.....	3-38
- CHECK	Front and rear axle differential seals.....	3-38
- CHECK	Front and rear wheel reduction gear seals.....	3-38
- CHECK	Remote control unit.....	3-38
- BLEED	Water separator.....	3-38
- CHECK	230 V electric power socket in the platform (OPTION).....	3-38
- CHECK	Electric generator (OPTION).....	3-38
- CHECK	Condition of pipe support (ATTACHMENT).....	3-38
- CHECK	Condition of panel support (ATTACHMENT).....	3-38
- CHECK	Alternator/fan belt.....	3-39
- CHECK	Wheel nut tightening.....	3-40
- CHECK	Tightening of the fixing screws for the oscillating cylinders.....	3-40
- CHECK	Tightening of the transmission shaft fixing screws.....	3-40
- CHECK	Tightening of the fixing screws for the axles.....	3-41
- CHECK	Locking of the front axle oscillating cylinders.....	3-42
- CHECK	Overload system 260 TJ+	3-43
- CHECK	Overload system 280 TJ	3-44
- CHECK	Brakes.....	3-46
- CHECK	Turntable rotation motor oil level.....	3-47
- CHECK	Emergency controls.....	3-47
- CHECK	Tightening of 12 V electrical connections.....	3-48
- LUBRICATE	Shafts, hubs and cylinder rings 260 TJ+	3-49
- LUBRICATE	Shafts, hubs and cylinder rings 280 TJ	3-50
- GREASE	Telescopic arm.....	3-51
- GREASE	Telescopic jib arm 280 TJ	3-51
- LUBRICATE	Crown gear.....	3-52
- BLEED	Fuel tank.....	3-53
- RESET	Maintenance warning.....	3-53

➔ ② 500H - PERIODIC MAINTENANCE - EVERY 500 HOURS OF SERVICE OR 1 YEAR

ALSO PERFORM THE DAILY SERVICE AND THE PERIODIC SERVICE AT 250 HOURS OF SERVICE.

- CHECK	Tilt sensor	3-54
- CHECK	Tightening of the platform fixing screws	3-54
- CHECK	Tightening of the platform rotation cylinder fixing screws	3-55
- CHECK	Chocking of the telescopic jib arm 280 TJ	3-56
- CHECK	Chocking of telescopic arm	3-57
- CHECK	Tightening of the fixing screws on the telescopic arm cylinder	3-58
- CHECK	Tightening of the fixing screws for the crown gear	3-58
- CHECK	Tightening of the fixing screws on the turntable rotation motor	3-59
- CHECK	Tightening of cast iron counterweight fixing screws	3-59
- CHECK	Tightening of concrete counterweight fixing screws	3-59
- CHECK	Tightening of the fixing screws for the lifting points	3-60
- CHECK	Hydraulic hoses	3-60
- REPLACE	Water separator filter cartridge	3-61
- REPLACE	Fuel filter cartridge	3-62
- REPLACE	Outside air filter cartridge	3-63
- REPLACE	Turntable rotation motor oil	3-64
- REPLACE	Hydraulic pressure filter cartridge	3-64
- REPLACE	Hydrostatic transmission filter cartridge	3-65
- RESET	Maintenance warning	3-65

➔ ③ 1000H - PERIODIC MAINTENANCE - EVERY 1000 HOURS OF SERVICE OR 2 YEARS

ALSO PERFORM THE DAILY SERVICE AND THE PERIODIC SERVICES AT 250 HOURS AND 500 HOURS OF SERVICE.

- REPLACE	Inside air filter cartridge	3-66
- REPLACE	Coolant	3-66
- REPLACE	Diesel engine oil	3-67
- REPLACE	- REPLACE Diesel engine oil filter	3-67
- REPLACE	Reduction gearbox oil	3-68
- REPLACE	Front and rear axle differential oil	3-68
- REPLACE	Front and rear wheel reduction gear oil	3-69
- REPLACE	Hydraulic oil	3-70
- CLEAN	Filling filter and suction strainer	3-70
- CHECK	Diesel engine silent blocks *	3-71
- CHECK	Diesel engine speeds *	3-71
- CHECK	Hydrostatic transmission circuit pressure *	3-71
- CHECK	Clearance of slewing ring gear *	3-71
- CHECK	Condition of the telescopic arm cables *	3-71
- CHECK	Speeds of hydraulic movements *	3-71
- CHECK	Condition of cylinders *	3-71
- CHECK	Condition of electric wiring *	3-71
- REPLACE	Injection pipes, fuel hoses and the hose clamps *	3-71
- REPLACE	Hoses and hose clamps for the coolant radiator *	3-71
- REPLACE	Lubrication hoses *	3-71
- REPLACE	Air intake line and air suction hose *	3-71
- RESET	Maintenance warning	3-71

*** Consult your dealer.**

➔ ④ 1500H - PERIODIC MAINTENANCE - EVERY 1500 HOURS OF SERVICE OR 3 YEARS

- CHECK	Air circulation system in the engine crankcase *	3-72
- RESET	Maintenance warning	3-72

*** Consult your dealer.**

➔ 5 2000H - PERIODIC MAINTENANCE - EVERY 2000 HOURS OF SERVICE OR 4 YEARS

- CHECK	Coolant and oil radiators *	3-72
- CHECK	Clearance of valve seats *	3-72
- CHECK	Hydraulic circuit pressures *	3-72
- RESET	Maintenance warning	3-72

** Consult your dealer.*

➔ 6 3000H - PERIODIC MAINTENANCE - EVERY 3000 HOURS OF SERVICE OR 6 YEARS

- CHECK	Engine ECU (ECU) and associated sensors and actuators *	3-72
- CHECK	Diesel oxidation catalyst (DOC) of the diesel particulate filter (DPF) *	3-72
- CHECK	Intake valve *	3-72
- CHECK	Exhaust valve *	3-72
- CHECK AND CLEAN	Exhaust gas recirculation system valve (EGR) *	3-72
- CHECK AND CLEAN	Injectors *	3-72
- CLEAN	Exhaust gas recirculation (EGR) system cooler *	3-72
- RESET	Maintenance warning	3-72

** Consult your dealer.*

➔ 7 6000H - PERIODIC MAINTENANCE - EVERY 6000 HOURS OF SERVICE OR 12 YEARS

- REPLACE	Telescopic arm cables *	3-72
-----------	-------------------------	------

** Consult your dealer.*

OCCASIONAL MAINTENANCE AND OCCASIONAL OPERATIONS

⚠ IMPORTANT ⚠

OCCASIONAL MAINTENANCE AND OCCASIONAL OPERATIONS MUST BE PERFORMED BY MAINTENANCE PERSONNEL OR AN APPROVED PROFESSIONAL FROM THE MANITOU NETWORK.

➔ OCCASIONAL MAINTENANCE

- REPLACE	Wheels	3-73
- REPLACE	Fuses/relays	3-74
- BLEED	Fuel supply circuit	3-76

➔ OCCASIONAL OPERATIONS

- USE	Swiveling engine support	3-77
-------	--------------------------	------

FILTER CARTRIDGES AND BELTS

➔ ① 250H - PERIODIC MAINTENANCE - EVERY 250 HOURS OF SERVICE OR 6 MONTHS



ALTERNATOR/FAN BELT

➔ ② 500H - PERIODIC MAINTENANCE - EVERY 500 HOURS OF SERVICE OR 1 YEAR



WATER SEPARATOR FILTER CARTRIDGE

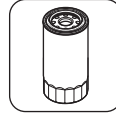

FUEL FILTER CARTRIDGE



OUTSIDE AIR FILTER CARTRIDGE



HYDRAULIC PRESSURE FILTER CARTRIDGE



HYDROSTATIC TRANSMISSION FILTER CARTRIDGE

➔ ③ 1000H - PERIODIC MAINTENANCE - EVERY 1000 HOURS OF SERVICE OR 2 YEARS

ALSO ADD THE FILTER CARTRIDGES AND BELTS FOR PERIODIC MAINTENANCE AT 250 HOURS AND 500 HOURS OF SERVICE.



INSIDE AIR FILTER CARTRIDGE



DIESEL ENGINE OIL FILTER

➔ OTHER FILTERS AND CARTRIDGES



FILLER CAP AND FILTER (HYDRAULIC OIL TANK)

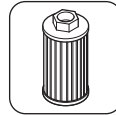

SUCTION STRAINER (HYDRAULIC OIL TANK)

LUBRICANTS, COOLANT AND FUEL

⚠ IMPORTANT ⚠

USE THE RECOMMENDED LUBRICANTS, COOLANT AND FUEL:

- For topping up, oils may not be miscible.
- For oil changes, MANITOU oils are perfectly appropriate.

ANALYSIS OF OILS

If a service or maintenance contract has been set up with the dealer, an analysis of the diesel engine oil and the hydraulic oil is requested depending on the rate of use.

(*) REQUIRED FUEL SPECIFICATION

Use a high-quality fuel to obtain optimal performance of the diesel engine.

- EN590 diesel fuel (sulfur content < 10 ppm).
- ASTM D975 diesel fuel (sulfur content < 15 ppm).

RECOMMENDATION

DIESEL ENGINE		
DESCRIPTION	CAPACITY	RECOMMENDATION
		-40 °C -30 °C -20 °C -10 °C 0 °C 10 °C 20 °C 30 °C 40 °C 50 °C
DIESEL ENGINE OIL	7.4 L	5W30
		10W30
		MANITOU OIL EVOLGY 10W40 API CJ4
		15W40
		-40 °C -30 °C -20 °C -10 °C 0 °C 10 °C 20 °C 30 °C 40 °C 50 °C
COOLING CIRCUIT	3 L	COOLANT -35 °C
		-40 °C -30 °C -20 °C -10 °C 0 °C 10 °C 20 °C 30 °C 40 °C 50 °C
FUEL TANK	76 L	HP NON-ROAD DIESEL (GNR) *
HYDRAULICS		
DESCRIPTION	CAPACITY	RECOMMENDATION
		-40 °C -30 °C -20 °C -10 °C 0 °C 10 °C 20 °C 30 °C 40 °C 50 °C
HYDRAULIC OIL TANK	94 L	ISO VG 100
		ISO VG 68
		MANITOU HYDRAULIC OIL ISO VG 46
		ISO VG 37
		ISO VG 32
TRANSMISSION		
DESCRIPTION	CAPACITY	RECOMMENDATION
		-40 °C -30 °C -20 °C -10 °C 0 °C 10 °C 20 °C 30 °C 40 °C 50 °C
REDUCTION GEARBOX	0.8 L	MANITOU MECHANICAL TRANSMISSION OIL SAE80W90
REAR AXLE		
DESCRIPTION	CAPACITY	RECOMMENDATION
		-40 °C -30 °C -20 °C -10 °C 0 °C 10 °C 20 °C 30 °C 40 °C 50 °C
DIFFERENTIAL	7.8 L	SPECIAL MANITOU OIL FOR IMMersed BRAKES
		-40 °C -30 °C -20 °C -10 °C 0 °C 10 °C 20 °C 30 °C 40 °C 50 °C
WHEEL GEAR REDUCER	2 x 0.8 L	MANITOU MECHANICAL TRANSMISSION OIL SAE80W90
		-40 °C -30 °C -20 °C -10 °C 0 °C 10 °C 20 °C 30 °C 40 °C 50 °C
WHEEL GEAR REDUCER PIVOTS		MANITOU BLACK MULTI-PURPOSE LUBRICANT

FRONT AXLE											
DESCRIPTION	CAPACITY	RECOMMENDATION									
		-40 °C	-30 °C	-20 °C	-10 °C	0 °C	10 °C	20 °C	30 °C	40 °C	50 °C
DIFFERENTIAL	7.8 L	SPECIAL MANITOU OIL FOR IMMersed BRAKES									
		-40 °C	-30 °C	-20 °C	-10 °C	0 °C	10 °C	20 °C	30 °C	40 °C	50 °C
WHEEL GEAR REDUCER	2 x 0.8 L	MANITOU MECHANICAL TRANSMISSION OIL SAE80W90									
		-40 °C	-30 °C	-20 °C	-10 °C	0 °C	10 °C	20 °C	30 °C	40 °C	50 °C
WHEEL GEAR REDUCER PIVOTS		MANITOU BLACK MULTI-PURPOSE LUBRICANT									
		-40 °C	-30 °C	-20 °C	-10 °C	0 °C	10 °C	20 °C	30 °C	40 °C	50 °C
OSCILLATION BEARINGS		MANITOU BLACK MULTI-PURPOSE LUBRICANT									

LIFTING STRUCTURE											
DESCRIPTION	CAPACITY	RECOMMENDATION									
		-40 °C	-30 °C	-20 °C	-10 °C	0 °C	10 °C	20 °C	30 °C	40 °C	50 °C
GENERAL GREASING		MANITOU BLACK MULTI-PURPOSE LUBRICANT									
		-40 °C	-30 °C	-20 °C	-10 °C	0 °C	10 °C	20 °C	30 °C	40 °C	50 °C
GREASING THE TELESCOPIC ARM		MANITOU BLACK MULTI-PURPOSE LUBRICANT									
		-40 °C	-30 °C	-20 °C	-10 °C	0 °C	10 °C	20 °C	30 °C	40 °C	50 °C
GREASING THE TELESCOPIC JIB ARM (280 TJ)		MANITOU BLACK MULTI-PURPOSE LUBRICANT									
		-40 °C	-30 °C	-20 °C	-10 °C	0 °C	10 °C	20 °C	30 °C	40 °C	50 °C
CROWN GEAR BEARINGS		MANITOU BLACK MULTI-PURPOSE LUBRICANT									
		-40 °C	-30 °C	-20 °C	-10 °C	0 °C	10 °C	20 °C	30 °C	40 °C	50 °C
CROWN GEAR TEETH		MANITOU MULTI-PURPOSE EXTREME PRESSURE LUBRICANT									
		-40 °C	-30 °C	-20 °C	-10 °C	0 °C	10 °C	20 °C	30 °C	40 °C	50 °C
TURNABLE ROTATION MOTOR	3 L	MANITOU MECHANICAL TRANSMISSION OIL SAE80W90									

⚠ IMPORTANT ⚠

Consult maintenance personnel if there is doubt about the condition of the machine.

Note: the turntable covers must be opened to carry out the general inspection of the machine. They must be put back in place and closed once finished.

The operator must perform a visual and physical inspection of the machine:

- Check that the operator's manual is clean and complete.
- Check the stickers and make sure they are all present, clean and legible, ☞ 2 - DESCRIPTION: STICKERS.
- Check for the absence of leaks: fuel, diesel engine oil, coolant, battery fluid, hydraulic oil, lubricants, etc.
- Check the condition of the structure: absence of impacts, damage, cracked welding, corrosion, excessive mechanical play, wear, etc.
- Check the condition of the platform: structure, floor, sliding mid rails, gate, harness attachment points, etc.
- Check the condition of the hydraulic components: pumps, distributors, valves, cylinders, hoses, etc.
- Check the condition of the mechanical components: wheels, tires, tie rods, crown gear, shafts, etc.
- Check the condition of the electrical components: control panels, foot switch, control handles, switches, buttons, indicator lights, batteries, fuses, cables, harnesses, rotating beacon light, etc.
- Check the condition of covers, handles, locks, plugs, etc.
- Check if any parts are missing or loose: screws, nuts, pins, etc.
- Check that no parts are missing or have had unauthorized modifications.
- Check the general cleanliness of the machine: platform floor, compartments, etc.

⚠ IMPORTANT ⚠

No flames or sparks. Do not smoke during this maintenance.

Never add fuel when the diesel engine has been started.

- Switch on the machine.
- Check the fuel level displayed on the ground level display screen.
- Make sure that the ground level display screen is working correctly and that all the information is visible.
- If the fuel level is low:
 - Open the fuel flap ①.
 - Remove the cap from the tank ②.
 - Add fuel until the maximum level is reached, ☞ LUBRICANTS, COOLANT AND FUEL.
 - Refit the tank cap.
 - Close the fuel flap.
- If the fuel level is correct:
 - Open the fuel flap ①.
 - Ensure that the tank cap ② is correctly closed.
 - Close the fuel flap.
- Switch off the machine.



CHECK

Diesel engine oil level

- Open the left-hand turntable cover.
- Remove the dipstick ①, clean it with a clean cloth and reinsert.
- Remove the dipstick. The level is correct when the oil is between the 2 marks A and B.
- If the level is low:
 - Put the dipstick back in place.
 - Remove the filler plug ②.
 - Add diesel engine oil, \triangleleft LUBRICANTS, COOLANT AND FUEL.
 - Refit the filler cap.
 - Wait 5 minutes for the oil to settle in the crankcase.
 - Remove the dipstick, clean it with a clean cloth and reinsert.
 - Remove the dipstick. The level is correct when the oil is between the 2 marks A and B.
 - Put the dipstick back in place.
- If the level is correct:
 - Put the dipstick back in place.
 - Ensure that the filler cap ② is correctly closed.

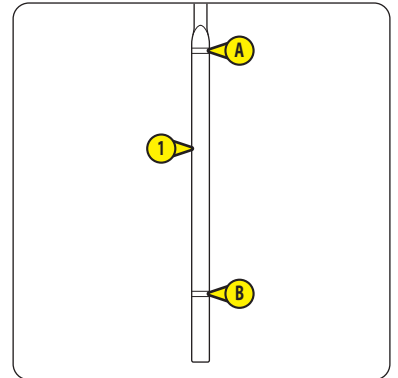
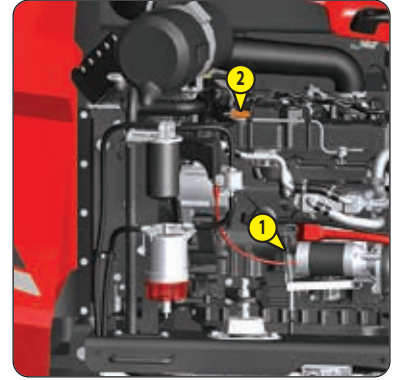

CHECK

Coolant level

⚠ IMPORTANT ⚠

*Wait until the diesel engine cools if it has been running for a while.
Do not remove the radiator cap until the diesel engine is completely cooled.*

- Note: the left-hand turntable cover is open.
- Remove the radiator cap ①. The level is correct when the coolant reaches the top of the filling hole.
 - If the level is low, add coolant until the correct level is reached, \triangleleft LUBRICANTS, COOLANT AND FUEL.
 - Refit the radiator cap.

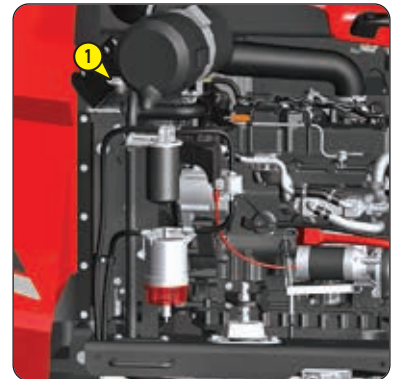

CHECK

Water separator

⚠ IMPORTANT ⚠

No flames or sparks. Do not smoke during this maintenance.

Note: the left-hand turntable cover is open.

- Clean the outside of the water separator ① with a clean cloth.
- Check the cleanliness of the fuel: there should be no impurities in the tank ②.
- Check that there is no water in the tank: the float ③ must be at the bottom of the tank.
- Consult maintenance personnel if there are impurities or water in the tank.
- Close the left-hand turntable cover.

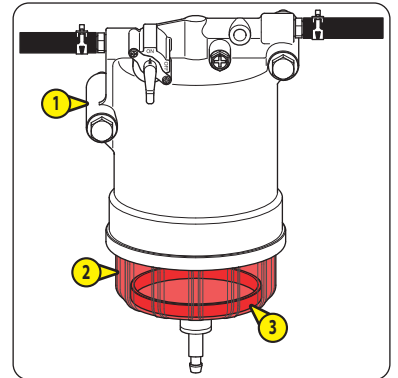
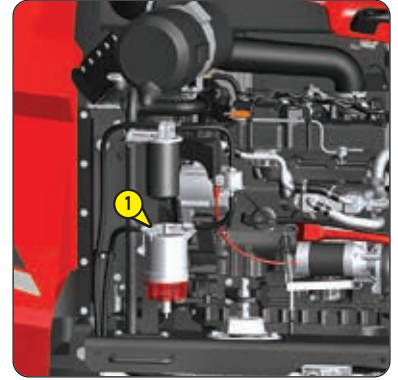

CHECK

Hydraulic oil level

⚠ IMPORTANT ⚠

The machine must be in transport position with the jib arm lowered completely.

There can be a difference in level between hot and cold oil. It is recommended the level is checked again when the hydraulic oil is hot.

Clean the oil can before adding oil to the hydraulic oil tank.

Use a clean funnel to add oil to the hydraulic oil tank.

- Open the right-hand turntable cover.
- Locate the level indicator ①. The level is correct when the oil reaches the red dot on the level indicator.
- If the level is low:
 - Remove the cap from the tank ②
 - Add hydraulic oil until the correct level is reached, ⚠ LUBRICANTS, COOLANT AND FUEL.
 - Refit the tank cap.
- If the level is correct:
 - Ensure that the tank cap ② is correctly closed.
- Close the right-hand turntable cover.

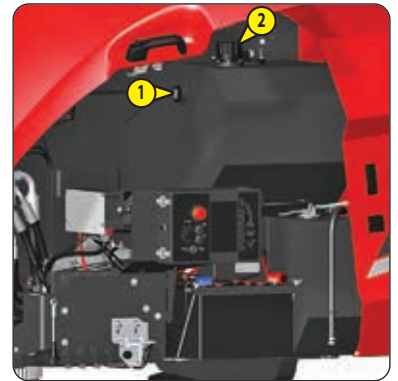

⚠ IMPORTANT ⚠

- ⚡ 2 - DESCRIPTION for more information on the control panels on the ground and in the platform.
 Select a test area on a firm, level surface that is free of any obstacles.
 Look around and above you when maneuvering the machine.
 Pay particular attention to electric lines and any object that may be within the machine's working area.
 Identify and shut the machine down if a malfunction is detected.

GROUND LEVEL CONTROL PANEL

Note:

- Permanent orange rotating beacon light activated: the orange rotating beacon light must come on when the machine is powered up.
- Permanent orange rotating beacon light deactivated: the orange rotating beacon light must come on when the machine's functions are activated.
- All movements alarm option activated: the horn sounds intermittently when the machine functions are activated.

POWERING ON AND STARTING THE DIESEL ENGINE AND EMERGENCY STOP

Note: the battery cut-off (option) is in the OFF position. The ignition key is in the OFF position .

Note: the machine is in transport position. The turntable and the platform are in neutral position. The jib arm is completely lowered.

- Ensure that the emergency stop buttons on the ground level control panel, the platform control panel and the remote control unit are in the ON position.
- Battery cut-off option: turn the battery cut-off to the ON position.

- Turn the ignition switch to the ON position .

Result:

- The ground level display screen must come on and the power-up cycle and then the preheat page must be displayed.
- The audible alarm should sound once.
- Secondary protection system option SPS: the flashing light SPS must flash several times and then go out.
- If the outside temperature is above -10 °C:
 - Wait for the preheat cycle to finish.
 - Press and hold down the start button.

Result:

- The diesel engine should start.
- Release the start button.
- If the outside temperature is below -10 °C:
 - Wait for the preheat cycle to finish.
 - Press and release the start mode button.
 - Press and hold down the start button.

Result:

- The diesel engine should start and run at high speed.
- Release the start button.
- Wait for between 30 and 60 seconds without using the machine's functions.
- Raise the main arm for 3 seconds.

Result:

- The diesel engine must idle.
- Fully lower the main arm.

Continuation: see next page.

- Press the emergency stop button.

Result:

- The emergency stop button should be pushed down in the OFF position.
- The diesel engine should stop.
- The ground level display screen should turn off.

- Pull the emergency stop button or turn it clockwise and release it.

Result:

- The emergency stop button should be in the ON position.
- The ground level display screen must come on and the power-up cycle and then the preheat page must be displayed.
- The audible alarm should sound once.
- Secondary protection system option SPS: the flashing light SPS must flash several times and then go out.

- Wait until the preheat cycle has finished and start the diesel engine.

MACHINE FUNCTIONS



During this test, turn the turntable by a small angle to avoid injury.

Note: the diesel engine has been started. The machine is in transport position. The turntable and the platform are in neutral position. The jib arm is completely lowered.

- Do not touch the activation switch. Try to activate all the machine's functions one by one.

Result:

- It should not be possible to activate any of the functions.

- Push and hold the activation switch to the right  (ground level controls position).
- Activate all the machine's functions one by one. Check that all the movements are complete up to the mechanical stops.

Result:

- It should be possible to activate all the functions.
- All the movements must operate correctly and smoothly.
- All the movements must be complete up to the mechanical stops.

- Place the machine in transport position. Put the turntable in neutral position. Level the platform/jib arm. Fully lower the jib arm.
- Release the activation switch.

OVERLOAD WARNING 260 TJ+

Note: the diesel engine has been started. The machine is in transport position. The turntable and the platform are in neutral position. The jib arm is completely lowered.

- Place a uniformly distributed load in the platform:
 - Pipe support or panel support not installed = between 449 kg and 479 kg.
 - Pipe support installed = between 434 kg and 464 kg.
 - Panel support installed = between 439 kg and 469 kg.

Result:

- An alert page must be displayed on the ground level display screen.
- The audible alarm should sound continuously.
- Try to activate all the machine's functions one by one.

Result:

- It should not be possible to activate any of the functions.
- Remove some of the load from the platform:
 - Pipe support or panel support not installed = between 41 kg and 71 kg to obtain a load of 408 kg in the platform.
 - Pipe support installed = between 41 kg and 71 kg to obtain a load of 393 kg in the platform.
 - Panel support installed = between 41 kg and 71 kg to obtain a load of 398 kg in the platform.

Result:

- The alert page should no longer be displayed.
- The audible alarm should stop.
- Activate all the machine's functions one by one.

Result:

- It should be possible to activate all the functions.
- Place the machine in transport position. Put the turntable in neutral position. Level the platform/jib arm. Fully lower the jib arm.

OVERLOAD WARNING 280 TJ

Note: the diesel engine has been started. The machine is in transport position. The turntable and the platform are in neutral position. The jib arm is completely lowered.

- Place a uniformly distributed load in the platform:
 - Pipe support or panel support not installed = between 385 kg and 415 kg.
 - Pipe support installed = between 370 kg and 400 kg.
 - Panel support installed = between 375 kg and 405 kg.

Result:

- An alert page must be displayed on the ground level display screen.
- The audible alarm should sound continuously.
- Try to activate all the machine's functions one by one.

Result:

- It should not be possible to activate any of the functions.
- Remove some of the load from the platform:
 - Pipe support or panel support not installed = between 35 kg and 65 kg to obtain a load of 350 kg in the platform.
 - Pipe support installed = between 35 kg and 65 kg to obtain a load of 335 kg in the platform.
 - Panel support installed = between 35 kg and 65 kg to obtain a load of 340 kg in the platform.

Result:

- The alert page should no longer be displayed.
- The audible alarm should stop.
- Activate all the machine's functions one by one.

Result:

- It should be possible to activate all the functions.
- Place the machine in transport position. Put the turntable in neutral position. Level the platform/jib arm. Fully lower the jib arm.

PLATFORM CONTROL PANEL

Note:

- Permanent orange rotating beacon light activated: the orange rotating beacon light must come on when the machine is powered up.
- Permanent orange rotating beacon light option deactivated: the orange rotating beacon light must come on when the machine functions are activated and when driving/steering the machine.
- All movements alarm option activated: the horn must sound intermittently when the machine functions are activated and when driving/steering the machine.
- Driving/steering alarm option activated: the horn should sound intermittently when driving/steering the machine.

OVERLOAD WARNING 260TJ+

Note: the diesel engine has been started. The machine is in transport position. The turntable and the platform are in neutral position. The jib arm is completely lowered.

Note:

- Pipe support or panel support not installed: a load of 408 kg is in the platform.
 - Pipe support installed: a load of 393 kg is in the platform.
 - Panel support installed: a load of 398 kg is in the platform.
- Get into the platform.

Result:

- The overload indicator light should flash.
 - The audible alarm should sound continuously.
- Try to activate all the machine's functions one by one.

Result:

- It should not be possible to activate any of the functions.
- Get out of the platform.

Result:

- The overload indicator light should go out.
 - The audible alarm should stop.
- Remove the whole load from the platform.

OVERLOAD WARNING 280TJ

Note: the diesel engine has been started. The machine is in transport position. The turntable and the platform are in neutral position. The jib arm is completely lowered.

Note:

- Pipe support or panel support not installed: a load of 350 kg is in the platform.
 - Pipe support installed: a load of 335 kg is in the platform.
 - Panel support installed: a load of 340 kg is in the platform.
- Get into the platform.

Result:

- The overload indicator light should flash.
 - The restricted capacity indicator light should be on.
 - The audible alarm should sound continuously.
- Try to activate all the machine's functions one by one.

Result:

- It should not be possible to activate any of the functions.
- Get out of the platform.

Result:

- The overload indicator light should go out.
- The restricted capacity indicator light should remain on.
- The audible alarm should stop.

Continuation: see next page.

- Remove the whole load from the platform.
- Get into the platform.

Result:

- The restricted capacity indicator light must be off.
- Raise the jib arm to the horizontal position.
- Fully extend the telescopic jib arm.
- Fully extend the telescopic arm.

Result:

- The restricted capacity indicator light should flash.
- Lower the jib arm.
- Get out of the platform.
- Place a uniformly distributed load in the platform:
 - Pipe support or panel support not installed = between 264 kg and 294 kg less your own weight.
 - Pipe support installed = between 249 kg and 279 kg less your own weight.
 - Panel support installed = between 254 kg and 284 kg less your own weight.
- Get into the platform.

Result:

- The overload indicator light should flash.
- The restricted capacity indicator light should be on.
- The audible alarm should sound continuously.
- Try to activate all the machine's functions one by one.

Result:

- It should not be possible to activate any of the functions.
- Get out of the platform.

Result:

- The overload indicator light should go out.
- The restricted capacity indicator light should flash.
- The audible alarm should stop.
- From the ground level control panel:
 - Retract the telescopic arm for 10 seconds.
 - Lower the jib arm.
- Get into the platform.

Result:

- The restricted capacity indicator light should be on.
- Try to fully extend the telescopic arm.

Result:

- The telescopic arm should not extend completely.
- Lower the jib arm.
- Get out of the platform.
- Remove the whole load from the platform.
- Place the machine in transport position. Put the turntable in neutral position. Level the platform. Fully lower the jib arm.

STARTING THE DIESEL ENGINE AND EMERGENCY STOP

Note: the diesel engine has been started. The machine is in transport position. The turntable and the platform are in neutral position. The jib arm is completely lowered.

- Press the emergency stop button.

Result:

- The emergency stop button should be pushed down in the OFF position.
- The diesel engine should stop.

- Pull the emergency stop button or turn it clockwise and release it.

Result:

- The emergency stop button should be in the ON position.
- The preheat indicator light should light up.
- The audible alarm should sound once.
- Secondary protection system option SPS: the flashing light SPS must flash several times and then go out.

- Wait until the preheat cycle has finished and start the diesel engine.

Result:

- The diesel engine should start.

- Raise the jib arm, at the same time pressing the emergency stop button.

- Result:

- The emergency stop button should be pressed down in the OFF position.
- The jib arm should stop.

- Pull the emergency stop button or turn it clockwise and release it to put it in the ON position.

- Wait until the preheat cycle has finished and start the diesel engine.

- Fully lower the jib arm.

HORN

Note: the diesel engine has been started. The machine is in transport position. The turntable and the platform are in neutral position. The jib arm is completely lowered.

- Press and release the horn button.

Result:

- The horn should sound.

PLATFORM TILT 280 TJ

⚠ IMPORTANT ⚠

During this test, tilt the platform up and down slightly to avoid injury.

Note: the diesel engine has been started. The machine is in transport position. The turntable and the platform are in neutral position. The jib arm is completely lowered.

- Do not touch the foot switch. Try to tilt the platform up and down.

Result:

- It should not be possible to activate any of the functions.

- Press and hold down the foot switch.

- Raise the jib arm slightly.

- Tilt the platform up and down slightly.

Result:

- It should be possible to activate the functions.

- Extend the telescopic arm for 3 seconds.

Result:

- It should be possible to activate the function.

- Try to tilt the platform up and down.

Result:

- It should not be possible to activate the functions.

- Fully retract the telescopic arm. Level the platform. Fully lower the jib arm.

- Release the foot switch.

MACHINE FUNCTIONS (apart from PLATFORM TILT 280TJ and PLATFORM/JIB ARM TILT RESET)

Note: the diesel engine has been started. The machine is in transport position. The turntable and the platform are in neutral position. The jib arm is completely lowered.

Note: do not drive or steer the machine during this test.

- Do not touch the foot switch. Try to activate all the machine's functions one by one.

Result:

- It should not be possible to activate any of the functions.
- Press and hold down the foot switch.
- Activate all the machine's functions one by one. Check that all the movements are complete up to the mechanical stops.

Result:

- It should be possible to activate all the functions.
- All the movements must operate correctly and smoothly.
- All the movements must be complete up to the mechanical stops.
- Place the machine in transport position. Put the turntable in neutral position. Fully lower the jib arm.
- Release the foot switch.

PLATFORM/JIB ARM TILT RESET



During this test, make sure that the platform is as close to the ground as possible before entering.

Note: the engine has been started. The machine is in transport position. The turntable and the platform are in neutral position. The jib arm is completely lowered.

- From the ground level control panel:

- Raise the main arm slightly.
- Tilt the platform/jib arm down until the tilt is greater than 5°, refer to the gage **A** and the sticker **B** PLATFORM/JIB ARM TILT.
- Lower the main arm to bring the platform as close to the ground as possible.

- Get into the platform.

Result:

- The platform/jib arm tilt indicator light must be on.
- Press and hold down the foot switch.
- Raise the main arm slightly.
- Press and hold down the platform/jib arm tilt button.

Result:

- The platform/jib arm must be tilted up.
- Wait for the movement to stop automatically.

Result:

- The platform/jib arm tilt indicator light should go out.
- The audible alarm should sound once.
- The gage **A** must be on the 0° position on the sticker **B** PLATFORM/JIB ARM TILT.
- Release the platform/jib arm tilt button.
- Fully lower the main arm.
- Release the foot switch.

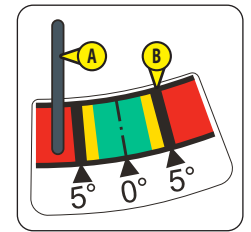

DRIVING/STEERING/BRAKING FUNCTIONS AND DRIVING SPEED SELECTION

Note: the diesel engine has been started. The machine is in transport position. The turntable and the platform are in neutral position. The jib arm is completely lowered.

Note: the 2 wheel alignment indicator lamps should be lit.

- Select 2 wheel steer mode .
- Do not touch the foot switch, do not touch the driving/steering control handle trigger. Try to drive and steer the machine.
- Do not touch the foot switch, press and hold down the driving/steering control handle trigger. Try to drive and steer the machine.
- Press and hold down the foot switch. Do not touch the driving/steering control handle trigger. Try to drive and steer the machine.

Result:

- It should not be possible to activate the functions.

- Select hare speed .
- Raise the jib arm slightly for better visibility.
- Press and hold down the foot switch. Press and hold down the driving/steering control handle trigger.
- Drive the machine forward and brake. Assess and remember the machine's braking distance.
- Drive the machine forward, test the steering and brake.

Result:

- It should not be possible to activate the driving/steering functions.
- Driving and steering should function properly and smoothly.
- The brakes should function properly.

- The driving speed must be hare speed .

- Reverse the machine for a short distance and brake.

Result:

- Driving should function properly and smoothly.
- The brakes should function properly.

- The driving speed must be ramp speed .

- Turn the turntable 45° to the left.
- Drive the machine forward and brake.

Result:

- Driving should function properly and smoothly.
- The brakes should function properly.

- The driving speed must be ramp speed .

- Put the turntable in neutral position.
- Turn the turntable 45° to the right.
- Drive the machine forward and brake.

Result:

- Driving should function properly and smoothly.
- The brakes should function properly.

- The driving speed must be ramp speed .

- Put the turntable in neutral position.
- Select tortoise speed .
- Drive the machine forward and brake. Assess and remember the machine's braking distance.
- Reverse the machine for a short distance and brake.

Continuation: see next page.

Result:

- Driving should function properly and smoothly.
- The brakes should function properly.
- The driving speed must be tortoise speed .

- Select ramp speed .

- Drive the machine forward and brake. Assess and remember the machine's braking distance.
- Reverse the machine for a short distance and brake.

Result:

- Driving should function properly and smoothly.
- The brakes should function properly.

• The driving speed must be ramp speed .

- Align the front wheels.



Result:



- The front wheel alignment indicator light should be lit.

- Release the foot switch.

STEERING MODE

Note: the diesel engine has been started. The machine is in transport position. The turntable and the platform are in neutral position. The jib arm is slightly raised.

Note: ramp speed  is selected. 2 wheel steer mode  is selected. The front and rear wheels are aligned.

- Select 4 wheel steer mode .
- Select hare speed .
- Steer to the left or right, drive the machine forward for a short distance and brake.
- Reverse the machine for a short distance and brake.

Result:

- Steering mode selection should function properly.
- Driving and steering should function properly and smoothly.
- The brakes should function properly.

- The driving speed must be ramp speed .

- Turn the turntable 45° to the left.
- Drive the machine forward and brake.

Result:

- Driving should function properly and smoothly.
- The brakes should function properly.
- The driving speed must be slow speed.

- Put the turntable in neutral position.
- Turn the turntable 45° to the right.
- Drive the machine forward and brake.

Result:

- Driving should function properly and smoothly.
- The brakes should function properly.
- The driving speed must be slow speed.

- Put the turntable in neutral position.
- Align the front and rear wheels.

Result:

- The 2 wheel alignment indicator lights should be lit.

- Select crab mode .
- Steer to the left or right, drive the machine forward for a short distance and brake.

Result:

- Steering mode selection should function properly.
- Driving and steering should function properly and smoothly.
- The brakes should function properly.

- The driving speed must be hare speed .

- Reverse the machine for a short distance and brake.

Result:

- Driving should function properly and smoothly.
- The brakes should function properly.

- The driving speed must be ramp speed .

- Align the front and rear wheels.

Result:

- The two wheel alignment indicator lights should come on.

- Select 2 wheel steer mode .

WORKING POSITION SPEED

Note: the diesel engine has been started. The machine is in transport position. The turntable and the platform are in neutral position. The jib arm is slightly raised.

Note: hare speed  is selected. 2 wheel steer mode  is selected. The front and rear wheels are aligned.

- Select tortoise speed .
- Drive the machine forward for a short distance and brake. Assess and remember the speed of the machine.
- Raise the main arm for 3 seconds.
- Drive the machine forward for a short distance and brake.

Result:

- The driving speed must be working speed.
- Fully lower the main arm.
- Drive the machine forward for a short distance and brake.

Result:

- The driving speed must be tortoise speed .
- Extend the telescopic arm for 3 seconds.
- Drive the machine forward for a short distance and brake.

Result:

- The driving speed must be working speed.
- Fully retract the telescopic arm.
- Drive the machine forward for a short distance and brake.

Result:

- The driving speed must be tortoise speed .

Note: end of test for 260 TJ+.

280 TJ:

- Extend the telescopic jib arm for 3 seconds.
- Drive the machine forward for a short distance and brake.

Result:

- The driving speed must be working speed.
- Fully retract the telescopic jib arm.
- Drive the machine forward for a short distance and brake.

Result:

- The driving speed must be tortoise speed .

DIFFERENTIAL LOCKING

Note: the diesel engine has been started. The machine is in transport position. The turntable and the platform are in neutral position. The jib arm is slightly raised.

Note: tortoise speed  is selected. 2 wheel steer mode  is selected. The front and rear wheels are aligned.

- Drive the machine forward and steer fully to the left or right.
- Press and hold down the differential lock button.

Result:

- The rear right-hand wheel or the rear left-hand wheel should slip.
- Align the front wheels.
- Release the differential lock button and brake the machine.
- Drive the machine forward and steer fully to the left or right.

Result:

- The wheel should no longer slip.
- Align the front wheels.
- Brake the machine.

DRIVING ON A SLOPE AND TILT WARNING

Note: the diesel engine has been started. The machine is in transport position. The turntable and the platform are in neutral position. The jib arm is slightly raised.

Note: tortoise speed  is selected. 2 wheel steer mode  is selected. The front and rear wheels are aligned.

TEST No. 1

- Select a slope between 10.5% (6°) and 35% (19°).
- Select ramp speed .
- Raise the jib arm to the horizontal position.
- Drive the machine forward slowly onto the slope, facing it, with the platform at the bottom of the slope.

Result:

- The oscillation tilt/lock indicator light should light up.
 - The audible alarm should sound intermittently.
- Brake the machine on the slope.

Result:

- The brakes should function properly.
 - The machine should be immobilized on the slope for at least 1 minute.
- Try to raise the main arm and extend the telescopic arm.
 - 280 TJ: try to extend the telescopic jib arm.

Result:

- It should not be possible to activate the functions.
- Reverse slowly to drive the machine off the slope onto a level surface.

Result:

- The oscillation tilt/lock indicator light should go out.
 - The audible alarm should stop.
- Brake the machine.

TEST No. 2

- Extend the telescopic arm for 3 seconds.

Result:

- Drive the machine forward slowly onto the slope, facing it, with the platform at the bottom of the slope.

Result:

- The machine should brake automatically.
 - The oscillation tilt/lock indicator light should light up.
 - The audible alarm should sound intermittently.
- Try to raise the main jib, extend the telescopic arm and drive/steer the machine.
 - 280 TJ: try to extend the telescopic jib arm and tilt the platform up/down.

Result:

- It should not be possible to activate the functions.
- Fully retract the telescopic arm.

Result:

- It should be possible to activate the function.
- Reverse slowly to drive the machine off the slope onto a level surface.

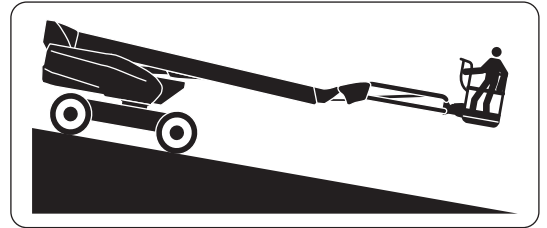

Result:

- The oscillation tilt/lock indicator light should go out.
 - The audible alarm should stop.
- Brake the machine.



TURNTABLE SLEWING ALARM

Note: the diesel engine has been started. The machine is in transport position. The turntable and the platform are in neutral position. The jib arm is slightly raised.

Note: ramp speed  is selected. 2 wheel steer mode  is selected. The front and rear wheels are aligned.

- Select hare speed .
- Turn the turntable to the left so that the turntable angle is greater than 90° relative to the neutral position.

Result:

- The turntable slewing indicator light should come on.
- Try to drive and steer the machine.

Result:

- It should not be possible to activate the functions.
- The audible alarm should sound twice when trying to drive.
- Press and release the turntable slewing button.

Result:

- The turntable slewing indicator light should flash.
- Drive the machine forward/backward and steer left/right. Match up the black and white arrows on the chassis and on the control panel in the platform to drive/steer the machine in the desired direction.
- Brake the machine.

Result:

- It should not be possible to activate the driving/steering functions.
- The colors of the white and black arrows should make it possible to drive/steer the machine in the desired direction.
- The driving speed must be slow speed.
- Turn the turntable to the right so that the turntable angle is less than 90° relative to the neutral position.

Result:

- The turntable slewing indicator light should go out.
- Repeat the test from the start by turning the turntable to the right.
- Put the turntable in neutral position.
- Align the front wheels.
- Fully lower the jib arm.
- Get out of the platform.
- Switch off the machine.

SECONDARY PROTECTION SYSTEM SPS (OPTION)

- Switch on the machine.

Result:

- The audible alarm should sound once.
- The flashing light SPS should flash several times and then go out.
- Start the diesel engine from the ground level control panel.
- Get into the platform.
- Check the condition of the safety cable SPS. If there is doubt about its condition, have it replaced by an approved professional from the Manitou network.
- Raise the jib arm slightly.
- Extend the telescopic arm for 3 seconds.
- Turn the platform to the right or left. At the same time, push the safety cable SPS forward and release it.

Result:

- The platform rotation should stop.
- The flashing light SPS should flash.
- The horn should sound intermittently.
- Try to activate all the machine's functions one by one.

Result:

- It should not be possible to activate any of the functions.
- Press and release the reset button SPS.

Result:

- The flashing light SPS should go out.
- The horn should stop.
- Fully retract the telescopic arm.

Result:

- It should be possible to activate the function.
- Extend the telescopic arm for 3 seconds.
- Turn the platform to the right or left. At the same time, push and hold the safety cable SPS forward.

Result:

- The platform rotation should stop.
- The flashing light SPS should flash.
- The horn should sound intermittently.
- Press and release the reset button SPS without releasing the safety cable SPS.
- Fully retract the telescopic arm.

Result:

- It should be possible to activate the function.
- Release the safety cable SPS.

Result:

- The flashing light SPS should go out.
- The horn should stop.
- Fully lower the jib arm.
- Get out of the platform.
- Switch off the machine.

➔ MONTHLY MAINTENANCE OR EVERY 50 HOURS OF SERVICE

ALSO PERFORM THE DAILY MAINTENANCE.

CHECK

Injection pipes, fuel hoses and the hose clamps

⚠ IMPORTANT ⚠



No flames or sparks. Do not smoke during this maintenance.

If there is doubt about the condition of the injection pipes, fuel hoses and hose clamps, have them replaced by an authorized professional from the Manitou network.

- Open the left and right-hand turntable covers.
- Open the swiveling engine support, OCCASIONAL OPERATIONS.
- Check the condition of all the injection pipes, fuel hoses and the tightening clamps.
- Check for fuel leaks.
- Close the swiveling engine support, OCCASIONAL OPERATIONS.
- Close the left and right-hand turntable covers.

CHECK

Reduction gearbox seals

- Locate the reduction gearbox  on the rear axle.
 - Check no oil is leaking from the reduction gearbox and plugs.
 - If a leak is detected:
 - Clean the outside of the reduction gearbox with a clean cloth.
 - Remove one of the 2 filler plugs .
- Note: 2 filler caps, left and right sides.
- Check that the oil reaches the filling hole.
 - Add oil if necessary, LUBRICANTS, COOLANT AND FUEL.
 - Refit the filler cap.



CHECK

Front and rear axle differential seals

- Check for oil leaks from the axle differentials and plugs.
- If a leak is detected:
 - Clean the outside of the axle differential with a clean cloth.
 - Remove the filler plug .
 - Check that the oil reaches the filling hole.
 - Add oil if necessary, LUBRICANTS, COOLANT AND FUEL.
 - Refit the filler cap.

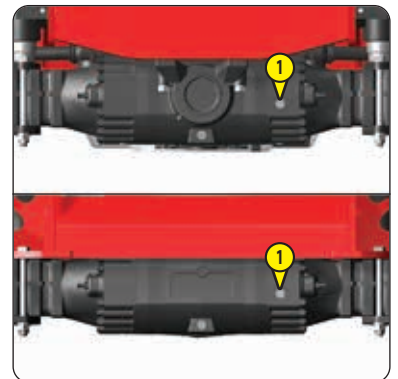

CHECK

Front and rear wheel reduction gear seals

Note: check the wheel reduction gears one by one.

- Check no oil is leaking from the gear reducers and plugs.
 - If a leak is detected:
 - Turn the wheel to put the drain/filler cap **1** in the horizontal position.
 - Clean the outside of the wheel reduction gear with a clean cloth.
 - Remove the drain/filler plug .
 - Check that the oil reaches the filling hole.
 - Add oil if necessary, **⚠ LUBRICANTS, COOLANT AND FUEL.**
 - Refit the drain/filler plug:
- Tightening torque = 42 N.m ± 7 N.m



CHECK

Remote control unit

⚠ IMPORTANT ⚠

⚠ 2 - DESCRIPTION for more information on the remote control unit.

Select a test area on a firm, level surface that is free of any obstacles.

Look around and above you when maneuvering the machine.

Pay particular attention to electric lines and any object that may be within the machine's working area.

Identify and shut the machine down if a malfunction is detected.

STARTING THE DIESEL ENGINE AND EMERGENCY STOP

- Start the diesel engine from the ground level control panel.

From the remote control unit:

- Press the emergency stop button.

Result:

- The emergency stop button should be pushed down in the OFF position.
- The diesel engine should stop.

- Pull the emergency stop button or turn it clockwise and release it.

Result:

- The emergency stop button should be in the ON position.
- The ground level display screen must come on and the power-up cycle and then the preheat page must be displayed.
- The audible alarm should sound once.
- Secondary protection system option SPS: the flashing light SPS must flash several times and then go out.

- Wait until the preheat cycle has finished and start the diesel engine.

MACHINE FUNCTIONS

Note: the diesel engine has been started.

- Do not touch the activation button. Try to activate all the machine's functions one by one.

Result:

- It should not be possible to activate any of the functions.

- Press and hold down the activation button. Activate all the machine's functions one by one.

Result:

- It should be possible to activate all the functions.
- All the movements must operate correctly and smoothly.

- 280 TJ: level the platform.
- Level the platform/jib arm.
- Fully lower the main arm.
- Release the activation button.
- Switch off the machine.

CLEAN

Coolant and oil radiators

⚠ IMPORTANT ⚠

Clean the radiators more often when the machine is operating in a dusty environment.

If there is any doubt about the condition of the hoses and hose clamps for the coolant radiator, have them replaced by an authorized professional from the Manitou network.

- Open the left-hand turntable cover.
- Open the swiveling engine support, ⚠ OCCASIONAL OPERATIONS.
- Clean the coolant radiator ① and the oil radiator ② with a brush to remove dust.
- Clean them with compressed air, from the inside out.
- Check the condition of the hoses and hose clamps for the coolant radiator.
- Check the condition of the oil radiator.
- Close the swiveling engine support, ⚠ OCCASIONAL OPERATIONS.



CLEAN

Outside air filter cartridge

⚠ IMPORTANT ⚠

Clean the outside air filter cartridge more often when the machine is operating in a dusty environment.

Never use the machine with a damaged air filter unit. If there is doubt about its condition, have it replaced by an approved professional from the Manitou network.

Never use the machine without the outside air filter cartridge or if it is damaged. If there is doubt about its condition, have it replaced by an approved professional from the Manitou network.

Never use the machine without the inside air filter cartridge or if it is damaged. If there is doubt about its condition, have it replaced by an approved professional from the Manitou network.

If there is doubt about the condition of the air intake line, the air suction outlet hose and hose clamps, have them replaced by an authorized professional from the Manitou network.

Note: the left-hand turntable cover is open.

- Clean the outside of the air filter unit ① with a clean, slightly damp cloth.
- Unlock and remove the cover ②.
- Clean the inside of the cover with a clean, slightly damp cloth.
- Remove the valve ③ and clean it with a clean, slightly damp cloth.
- Check the condition and replace it if it is damaged.
- Put the valve back in place.
- Remove the outside air filter cartridge ④, pulling it gently to prevent dust dispersion.

Note: do not press the center of the outside air filter cartridge.

- Check the condition of the inside air filter cartridge ⑤ without taking it out.
- Check the condition of the air filter unit, the air intake line, the air suction outlet hose and the tightening clamps.
- Clean the outside air filter cartridge ④ by tapping it gently.

Note: if necessary, clean it with dry compressed air, from the inside out. Maximum pressure = 2 bars. Minimum distance = 30 mm.

- Check its condition and clean its seal with a clean cloth.
- Refit the outside air filter cartridge, pushing it gently.

Note: do not press the center of the outside air filter cartridge.

- Refit the cover ②, with the valve ③ facing downward and the marking "TOP" facing upward.
- Close the left-hand turntable cover.

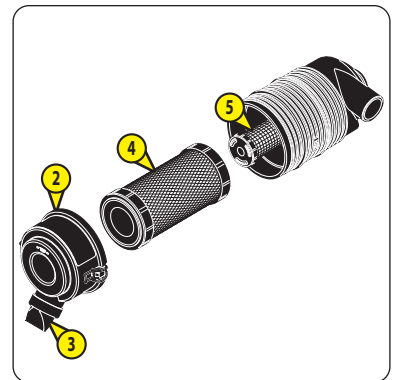
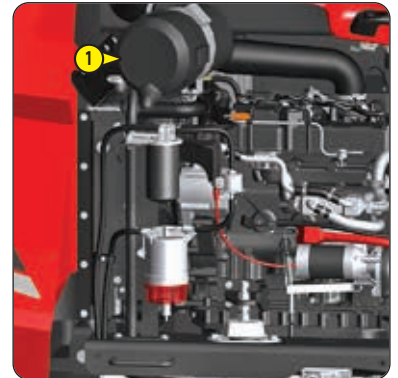

⚠ IMPORTANT ⚠

Lubricate the axles more often when the machine is operating in a dusty environment.

FRONT AND REAR STEERING PIVOTS

- Remove the caps from the lubrication connectors **1**, at the front and at the rear, on the right and left-hand sides.
- Inject lubricant into the lubrication connectors,  LUBRICANTS, COOLANT AND FUEL.
- Refit the caps of the lubrication connectors.

OSCILLATING FRONT AXLE BEARINGS

- Remove the caps from the lubrication connectors **2**.
- Inject lubricant into the lubrication connectors,  LUBRICANTS, COOLANT AND FUEL.
- Refit the caps of the lubrication connectors.

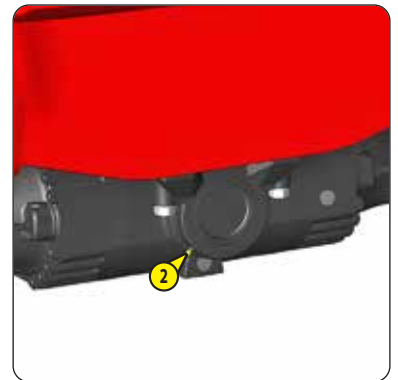

⚠ IMPORTANT ⚠

Wait until the diesel engine cools if it has been running for a while.

No flames or sparks. Do not smoke during this maintenance.

Bleed the water separator more often if impurities or water are regularly detected during daily maintenance.

- Check the fuel level. If necessary, add fuel until the maximum level is reached
 ◀ DAILY MAINTENANCE: CHECK FUEL LEVEL.
- Switch off the machine.
- Clean the outside of the water separator ① with a clean cloth and put a drain pan underneath.
- Turn the tap ② to the OFF position "OFF".
- Unscrew the bleed valve ③.
- If the water does not flow, undo the bleed screw ④ by 2 to 3 turns.
- If the water still does not flow, turn the valve ② to the on position "ON".
- Do up the bleed valve ③ by hand (tightening torque = 1.5 N.m ±0.5 N.m) when:
 - There are no impurities in the tank ⑤.
 - The float ⑥ is at the bottom of the tank.
- Do the bleed screw ④ back up if it has been loosened.
- Bleed the fuel supply circuit, ◀ OCCASIONAL MAINTENANCE.
- Check for fuel leaks from the water separator.
- Switch off the machine.

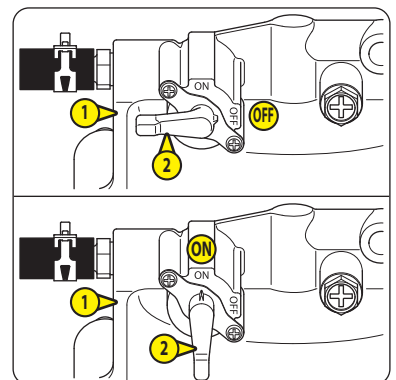
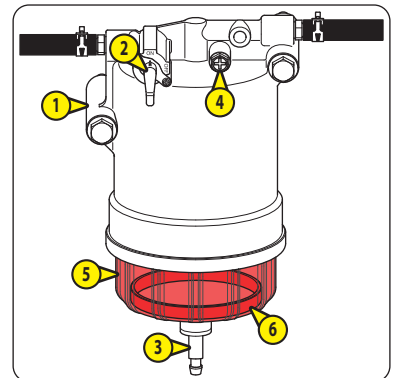
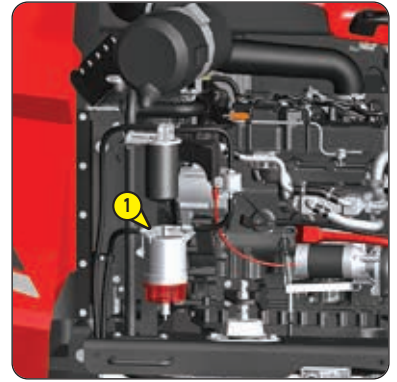

CHECK

230 V electric power socket in the platform (OPTION)

⚠ IMPORTANT ⚠

Connect the plug to a 230 V/50 Hz power source delivering 16 A.

Only connect electrical appliances that work with 230 V/50 Hz, 16 A maximum.

Do not connect extension cords, power supply bars or plugs with multiple sockets to the electric power socket.

Note: the illustrations show a 260 TJ+ with a standard platform.

- Connect the plug 1 to a power source.
- Plug an electrical appliance into the electric power socket 2A and turn it on.
- Switch it off, connect it to the electric power socket 2B and switch it on.
- Switch it off, connect it to the electric power socket 2C and switch it on.

Result:

- The electrical appliance should operate.

- Open the electrical box cover panel 3A.
- Press and release the test button 3B.

Result:

- The switch 3C must move from the ON position to the OFF position, the indicators 3D and 3E should be green.

- The electrical appliance should not operate.

- Turn off the power to the electrical appliance.
- Push the switch 3C to the ON position.

Result:

- The switch must remain in the ON position, the indicators should be red.

- Switch the electrical appliance on.

Result:

- The electrical appliance should operate.

- Disconnect the electrical appliance.
- Disconnect the electrical plug.

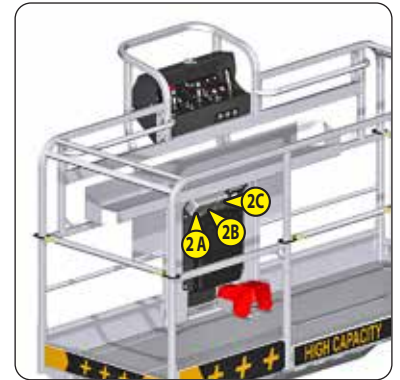

⚠ IMPORTANT ⚠

Only connect electrical appliances that work with:

- 110 V/50 Hz, 16 A maximum (110 V 3.5 kW electric generator option).

- 230 V/50 Hz, 16 A maximum (230 V 3.5 kW electric generator option and 230 V 5 kW electric generator option).

Do not connect extension cords, power supply bars or plugs with multiple sockets to the electric power socket(s).

Note: the illustrations show a standard 260 TJ+ platform.

- Start the diesel engine.
- Start the electric generator.
- 110 V 3.5 kW electric generator option:
 - Plug an electrical appliance into the electric power socket ① and turn it on.
- Result:
 - The electrical appliance should operate.
- 230 V 3.5 kW electric generator option and 230 V 5 kW electric generator option:
 - Plug an electrical appliance into the electric power socket ②A and turn it on.
 - Switch it off, connect it to the electric power socket ②B and switch it on.
 - Switch it off, connect it to the electric power socket ②C and switch it on.
- Result:
 - The electrical appliance should operate.
- Open the right-hand turntable cover.
- Locate the electric generator ③.
- Press and release the test button ③A.

- Result:
- The switch ③B must move from the ON position to the OFF position, the indicator ③C should be green.
 - The electrical appliance should not operate.
 - Turn off the power to the electrical appliance.
 - Push the switch ③B to the ON position.

- Result:
- The switch must remain in the ON position, the indicator should be red.
 - Switch the electrical appliance on.

- Result:
- The electrical appliance should operate.
 - Disconnect the electrical appliance.
 - Stop the generator.
 - Close the right-hand turntable cover.
 - Switch off the machine.

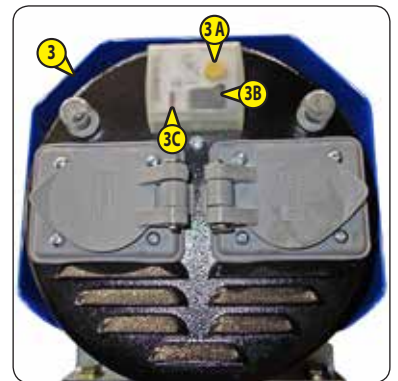
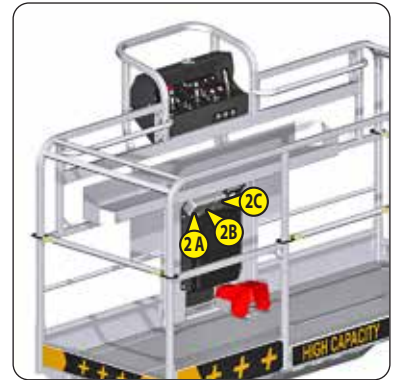
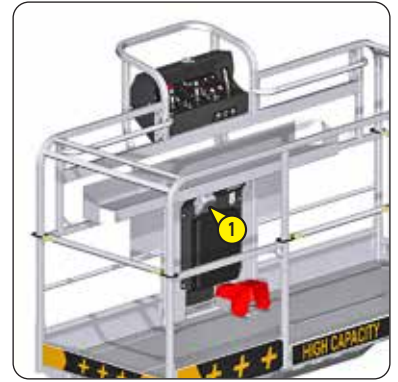

CHECK

Condition of pipe support (ATTACHMENT)

- Check the general condition of the components and the conformity of the installation, \triangleleft 4 - ATTACHMENTS: PIPE SUPPORT.

CHECK

Condition of panel support (ATTACHMENT)

- Check the general condition of the components, the conformity of the installation and the tightening torques, \triangleleft 4 - ATTACHMENTS: PANEL SUPPORT.

➔ 1 250H - PERIODIC MAINTENANCE - EVERY 250 HOURS OF SERVICE OR 6 MONTHS

ALSO PERFORM THE DAILY MAINTENANCE.

CHECK

Injection pipes, fuel hoses and the hose clamps

⚠ 50H: MONTHLY MAINTENANCE OR EVERY 50 HOURS OF SERVICE.

CHECK

Reduction gearbox seals

⚠ 50H: MONTHLY MAINTENANCE OR EVERY 50 HOURS OF SERVICE.

CHECK

Front and rear axle differential seals

⚠ 50H: MONTHLY MAINTENANCE OR EVERY 50 HOURS OF SERVICE.

CHECK

Front and rear wheel reduction gear seals

⚠ 50H: MONTHLY MAINTENANCE OR EVERY 50 HOURS OF SERVICE.

CHECK

Remote control unit

⚠ 50H: MONTHLY MAINTENANCE OR EVERY 50 HOURS OF SERVICE.

BLEED

Water separator

⚠ 50H: MONTHLY MAINTENANCE OR EVERY 50 HOURS OF SERVICE.

CHECK

230 V electric power socket in the platform (OPTION)

⚠ 50H: MONTHLY MAINTENANCE OR EVERY 50 HOURS OF SERVICE.

CHECK

Electric generator (OPTION)

⚠ 50H: MONTHLY MAINTENANCE OR EVERY 50 HOURS OF SERVICE.

CHECK

Condition of pipe support (ATTACHMENT)

⚠ 50H: MONTHLY MAINTENANCE OR EVERY 50 HOURS OF SERVICE.

CHECK

Condition of panel support (ATTACHMENT)

⚠ 50H: MONTHLY MAINTENANCE OR EVERY 50 HOURS OF SERVICE.

⚠ IMPORTANT ⚠*Ensure that the machine is switched off.**Replace the belt if there is any doubt about its condition.*

- Open the left-hand turntable cover.
- Check the condition of the belt ①. Ensure there are no cracks or signs of wear:
 - If the condition is correct, check the belt tension.
 - If the condition is not correct, replace the belt.

CHECK THE BELT TENSION

- Check the belt tension between the crankshaft pulley and the alternator pulley:
 - Apply pressure with the thumb = 98 N. The clearance A must be between 10 mm and 14 mm to be correct.
- Adjust if necessary:
 - Loosen the screws ②.
 - Adjust the belt tension by swiveling the alternator.
 - Tighten the screws ②.
 - Check the belt tension again.
- Close the left-hand turntable cover.

REPLACE THE BELT

- Replace the belt ①, < FILTER CARTRIDGES AND BELTS:
 - Loosen the screws ②.
 - Remove the used belt by swiveling the alternator.
 - Replace it with a new belt.
- Adjust the belt tension between the crankshaft pulley and the alternator pulley:
 - Apply pressure with the thumb = 98 N. The clearance A must be between 8 mm and 12 mm to be correct.
- Tighten the screws ②.
- Start the diesel engine.
- Allow it to idle for 5 minutes.
- Switch off the machine.
- Check the belt tension between the crankshaft pulley and the alternator pulley:
 - Apply pressure with the thumb = 98 N. The clearance A must be between 10 mm and 14 mm to be correct.
- Adjust if necessary:
 - Loosen the screws ②.
 - Adjust the belt tension by swiveling the alternator.
 - Tighten the screws ②.
 - Check the belt tension again.
- Close the left-hand turntable cover.

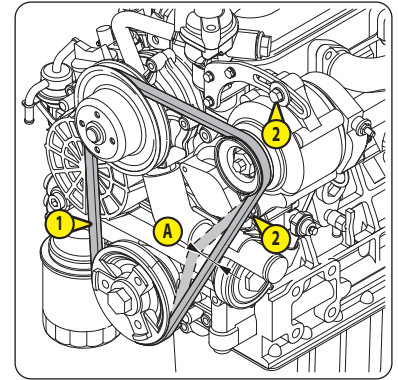

⚠ IMPORTANT ⚠

Failure to follow this instruction may result in the machine tipping over.

- Check the tightening torques of all the wheel nuts:
 - 550 N.m ±55 N.m

CHECK

Tightening of the fixing screws for the oscillating cylinders

⚠ IMPORTANT ⚠

Failure to follow this instruction may result in the machine tipping over.

- Remove the right and left covers **1**.
- Check the tightening torques of all the fixing screws **2**, on the left and right-hand sides:
 - 375 N.m ±74 N.m
- Put the covers back in place.



CHECK

Tightening of the transmission shaft fixing screws

⚠ IMPORTANT ⚠

Failure to follow this instruction may result in the machine running away.

- Check the tightening torques of all the fixing screws **1**, at the front and rear:
 - 38 N.m ±3.5 N.m



CHECK

Tightening of the fixing screws for the axles

⚠ IMPORTANT ⚠

Failure to follow this instruction may result in the machine tipping over.

- Check the tightening torques of all the fixing screws:
 - ① (Front axle, left and right sides) = 280 N.m \pm 28 N.m
 - ② (Front axle oscillating bearings) = 375 N.m \pm 74 N.m
 - ③ (rear axle, left and right sides) = 341 N.m \pm 68 N.m

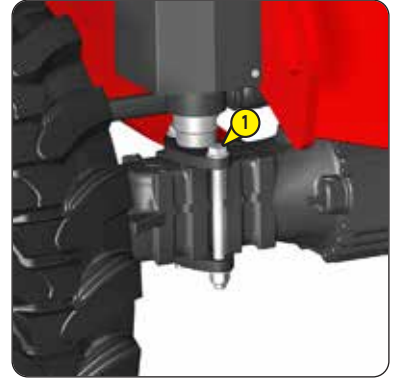

⚠ IMPORTANT ⚠

Failure to follow this instruction may result in the machine tipping over.

- Place a sufficiently solid ramp in front of the front right-hand wheel:
 - A = 7.5 cm minimum, 9 cm maximum.
 - B = 60 cm minimum.
 - C = 75 cm minimum, 100 cm maximum.
 - D = 10° minimum, 25° maximum.
- Start the diesel engine.
- Get into the platform.
- Select ramp speed .
- Raise the jib arm slightly.
- Drive the machine slowly forward until the front right-hand wheel is at the top of the ramp.
- Brake the machine.
- Turn the turntable 90° to the left.
- Extend the telescopic arm for 3 seconds.
- Reverse the machine slowly until the wheel is off the slope.
- Brake the machine.
- Ask someone on the ground to check the right front wheel and the oscillating cylinders.

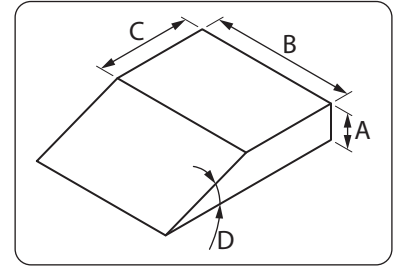

Result:

- The right front wheel should be in the upper position and not in contact with the ground.
- The right oscillating cylinder should be retracted and the left one extended.
- Ask the person on the ground to move away.
- Fully retract the telescopic arm.
- Ask the person on the ground to check the front wheels.

Result:

- The two front wheels must be in contact with the ground.
- Put the turntable in neutral position.
- Fully lower the jib arm.
- Get out of the platform.
- Place the same ramp in front of the left front wheel.
- Get into the platform.
- Raise the jib arm slightly.
- Drive the machine slowly forward until the front left-hand wheel is at the top of the ramp.
- Brake the machine.
- Turn the turntable 90° to the right.
- Extend the telescopic arm for 3 seconds.
- Reverse the machine slowly until the wheel is off the slope.
- Brake the machine.
- Ask the person on the ground to check the left front wheel and the oscillating cylinders.

Result:

- The left front wheel should be in the upper position and not in contact with the ground.
- The left oscillating cylinder should be retracted and the right one extended.
- Ask the person on the ground to move away.
- Fully retract the telescopic arm.
- Ask the person on the ground to check the front wheels.

Result:

- The two front wheels must be in contact with the ground.
- Put the turntable in neutral position.
- Fully lower the jib arm.
- Get out of the platform.

⚠ IMPORTANT ⚠

Failure to follow this instruction may result in the machine tipping over.

The PIPE SUPPORT or PANEL SUPPORT attachments must be removed before checking the overload system, 4 - ATTACHMENTS.

Refer to the machine repair manual if the overload system is not correctly calibrated.

Note: the diesel engine has been started. The machine is in transport position. The turntable and the platform are in neutral position. The jib arm is completely lowered. The panel support and the pipe support are not installed.

- Place a uniformly distributed load in the platform = 449 kg.

Result:

- An alert page must be displayed on the ground level display screen.
- The audible alarm should sound continuously.

- Try to activate all the machine's functions one by one using the ground level control panel.

Result:

- It should not be possible to activate any of the functions.

- Remove 41 kg to obtain a load of 408 kg in the platform:

Result:

- The alert page should no longer be displayed.
- The audible alarm should stop.

- Activate all the machine's functions one by one.

Result:

- It should be possible to activate all the functions.

- Place the machine in transport position. Put the turntable in neutral position. Level the platform/jib arm. Fully lower the jib arm.

- Get into the platform.

Result:

- The overload indicator light should flash.
- The audible alarm should sound continuously.

- Try to activate all the machine's functions one by one using the platform control panel.

Result:

- It should not be possible to activate any of the functions.

- Get out of the platform.

Result:

- The overload indicator light should go out.
- The audible alarm should stop.

- Remove the whole load from the platform.

- Switch off the machine.

⚠ IMPORTANT ⚠

Failure to follow this instruction may result in the machine tipping over.

The PIPE SUPPORT or PANEL SUPPORT attachments must be removed before checking the overload system,  4 - ATTACHMENTS.

Refer to the machine repair manual if the overload system is not correctly calibrated.

Note: the diesel engine has been started. The machine is in transport position. The turntable and the platform are in neutral position. The jib arm is completely lowered. The panel support and the pipe support are not installed.

- Place a uniformly distributed load in the platform = 264 kg less your body weight.
- Get into the platform.

Result:

- The restricted capacity indicator light should be on.
- Raise the jib arm to the horizontal position.
- Fully extend the telescopic jib arm.
- Try to fully extend the telescopic arm.

Result:

- The telescopic arm should not extend completely.
- Lower the jib arm.
- Get out of the platform.
- Remove 24 kg from the platform:
 - Load remaining in the platform = 240 kg less your body weight.
- Get into the platform.

Result:

- The restricted capacity indicator light must be off.
- Raise the jib arm to the horizontal position.
- Fully extend the telescopic arm.

Result:

- The telescopic arm should not extend completely.
- The restricted capacity indicator light should flash.
- Fully retract the telescopic arm.

Result:

- The restricted capacity indicator light should go out.
- Fully retract the telescopic jib arm.
- Fully lower the jib arm.
- Get out of the platform.
- Place a uniformly distributed load in the platform = 385 kg.

Result:

- An alert page must be displayed on the ground level display screen.
- The audible alarm should sound continuously.
- Try to activate all the machine's functions one by one using the ground level control panel.

Result:

- It should not be possible to activate any of the functions.
- Remove 35 kg to obtain a load of 350 kg in the platform.

Result:

- The alert page should no longer be displayed.
- The audible alarm should stop.

Continuation: see next page.

- Activate all the machine's functions one by one using the ground level control panel.

Result:

- It should be possible to activate all the functions.

- Place the machine in transport position. Put the turntable in neutral position. Level the platform/jib arm. Fully lower the jib arm.

- Get into the platform.

Result:

- The overload indicator light should flash.
- The restricted capacity indicator light should be on.
- The audible alarm should sound continuously.

- Try to activate all the machine's functions one by one using the platform control panel.

Result:

- It should not be possible to activate any of the functions.

- Get out of the platform.

Result:

- The audible alarm should stop.
- The overload indicator light should go out.
- The restricted capacity indicator light should remain on.

- Remove the whole load from the platform.

Result:

- The restricted capacity indicator light should go out.

- Switch off the machine.

⚠ IMPORTANT ⚠

*Failure to follow this instruction may result in the machine running away.
The PIPE SUPPORT or PANEL SUPPORT attachments must be removed before checking the overload system, 4 - ATTACHMENTS.*

PLACING IN FREEWHEEL MODE

Note: the machine is powered down. The machine is in transport position. The turntable and the platform are in neutral position. The jib arm is completely lowered.

- Carry out the complete procedure described in 2- DESCRIPTION: TRANSPORT AND LIFTING: FREEWHEEL FOR WINCHING.

BRAKING DISTANCE ON A LEVEL SURFACE

Note: the machine is powered down. The machine is in transport position. The turntable and the platform are in neutral position. The jib arm is completely lowered.

- Select a level surface for the following test.
- Start the diesel engine.
- Place a uniformly distributed load in the platform:
 - 260 TJ+ = 408 kg less your own weight.
 - 280 TJ = 350 kg less your own weight.
- Get into the platform.

- Select hare speed .
- Raise the jib arm slightly for better visibility.

Drive the machine forward until the top speed is reached.

- Release the control handle to brake the machine.

Result:

- The braking distance must be: 1,400 mm \pm 300 mm.
- Extend the telescopic arm for 3 seconds.
- Drive the machine forward until the top speed is reached:

Note: the driving speed must be working speed.

- Release the control handle to brake the machine.

Result:

- The braking distance must be: 200 mm \pm 50 mm.
- Fully retract the telescopic arm and fully lower the jib arm.

BRAKING ON A SLOPE

Note: the diesel engine has been started. The machine is in transport position. The turntable and the platform are in neutral position. The jib arm is slightly raised. The previous test load is in the platform.

- Select a slope of 25% (14°) for the following test.
- Raise the jib arm to the horizontal position.
- Drive the machine forward slowly onto the slope, facing it, with the platform at the bottom of the slope.
- Release the control handle to brake the machine on the slope.

Result:

- The machine should be immobilized on the slope for at least 1 minute.
- Drive the machine off the slope.
- Fully lower the jib arm.
- Get out of the platform.
- Remove the whole load from the platform.
- Switch off the machine.

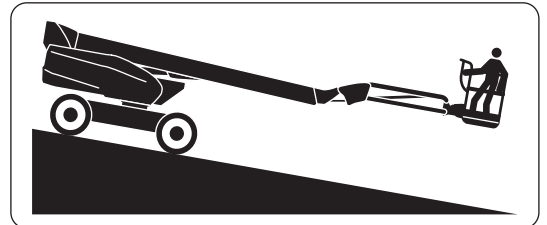

CHECK

Turntable rotation motor oil level

Note: the illustration shows a 260 TJ+.

- Open the right-hand turntable cover.
- Clean the outside of the turntable rotation motor ① with a clean cloth.
- Check for oil leaks.
- Remove the filler plug ②.
- Clean the dipstick on the filler cap with a clean cloth and put it back in place.
- Remove the filler cap. The level is correct when the oil is between the 2 marks ① and ②.
- If the level is low, add oil until the correct level is reached, LUBRICANTS, COOLANT AND FUEL.
- Refit the filler cap.
- Close the right-hand turntable cover.

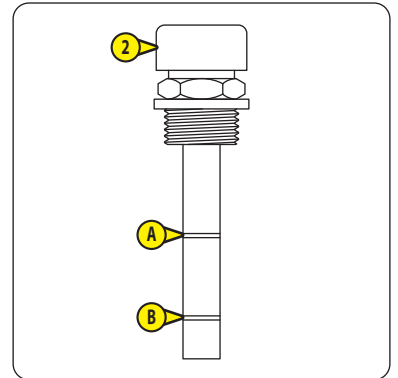
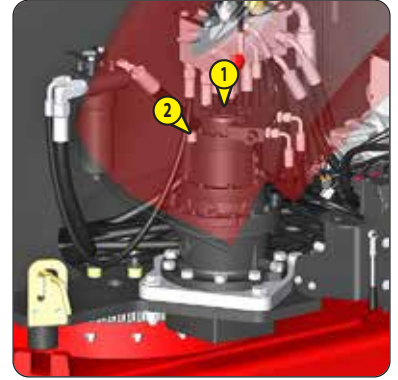

CHECK

Emergency controls

⚠ IMPORTANT ⚠

Use of the machine if there is a malfunction is prohibited.

- Check that the emergency controls are working: carry out the complete procedures described in 2 - DESCRIPTION: EMERGENCY CONTROLS.
- Place the machine in transport position. Put the turntable in neutral position. Level the platform/jib arm. Fully lower the jib arm.
- Switch off the machine.

⚠ IMPORTANT ⚠

Electrical accreditation may be required for this maintenance operation: comply with local, governmental and national regulations in force.

Disconnect the battery before working on the electrical system.

Make sure that the positive terminals cannot come into contact with the negative terminals or the metallic parts of the machine at any time.



After each job, make sure that the electrical component protection systems are put back (covers, caps, grommets, etc.).

- Open the left and right-hand turntable covers.
- Open the swiveling engine support, OCCASIONAL OPERATIONS.
- Check the condition of the 12 V electrical wires:
 - Between the battery and the turntable.
 - Without battery cut-off option: between the battery and the fuse box.
 - With battery cut-off option: between the battery and the battery cut-off.
 - With battery cut-off option: between the battery cut-off and the fuse box.
 - Between the fuse box and the backup pump.
 - Between the fuse box and the starter.
 - Without battery cut-off option: between the starter and the alternator.
 - With battery cut-off option: between the battery cut-off and the alternator
 - Between the fuse box and the fuse/relay box.
- Check the condition of the ground braid between the diesel engine and the turntable.
- Check the tightening of the 12 V electrical connections:
 - On the battery.
 - With battery cut-off option: on the battery cut-off.
 - On the fuse box.
 - On the fuse/relay box.
 - On the backup pump.
 - On the starter
 - On the alternator.
 - On the turntable (ground braid).
- Close the swiveling engine support, OCCASIONAL OPERATIONS.
- Close the left and right-hand turntable covers.

⚠ IMPORTANT ⚠

Always secure the raised arms with a suitable lifting device.

- Start the diesel engine.
- Perform the appropriate main arm, jib arm and platform/jib arm tilt movements to access the various lubricators. Secure the raised arms with a suitable lifting device.
- Open the left-hand turntable cover.
- Remove the caps of the lubrication connectors.
- Inject lubricant into each lubrication connector, ⚡ LUBRICANTS, COOLANT AND FUEL.
- Refit the caps of the lubrication connectors.
- Fully lower the main arm. Level the platform/jib arm. Fully lower the jib arm.

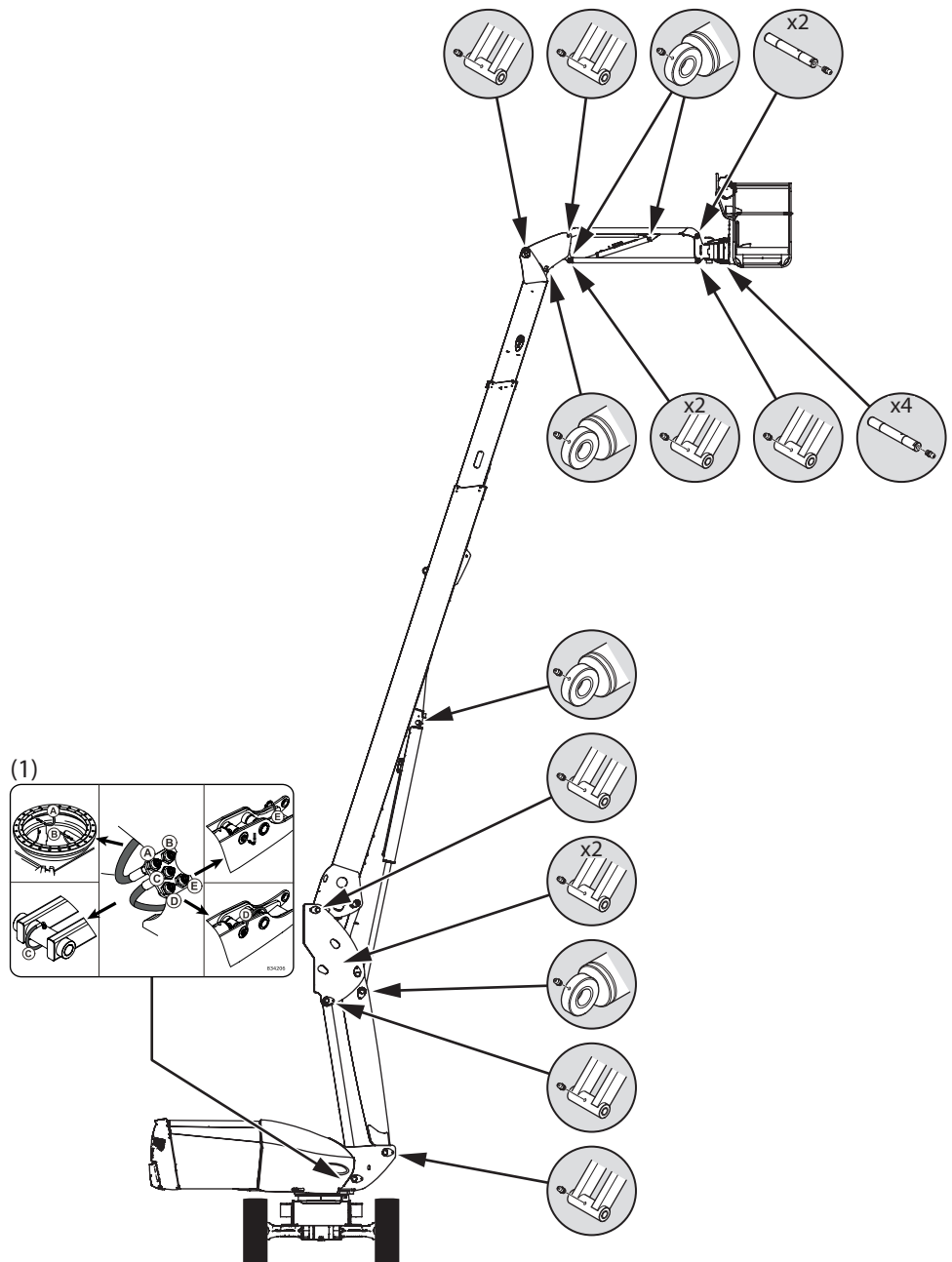

KEY
AXIS

HUB

CYLINDER RING

(1) ⚡ 2 - DESCRIPTION: STICKERS: REMOTE LUBRICATION. Note: the lubricators are located under the left-hand turntable cover. Note: Ⓐ and Ⓑ, ⚡ LUBRICATE: RING GEAR.



⚠ IMPORTANT ⚠

Always secure the raised arms with a suitable lifting device.

- Start the diesel engine.
- Perform the appropriate main arm, jib arm and platform/jib arm tilt movements to access the various lubricators. Secure the raised arms with a suitable lifting device.
- Open the left-hand turntable cover.
- Remove the caps of the lubrication connectors.
- Inject lubricant into each lubrication connector, ◀ LUBRICANTS, COOLANT AND FUEL.
- Refit the caps of the lubrication connectors.
- Fully lower the main arm. Level the platform/jib arm. Fully lower the jib arm.

KEY
AXIS

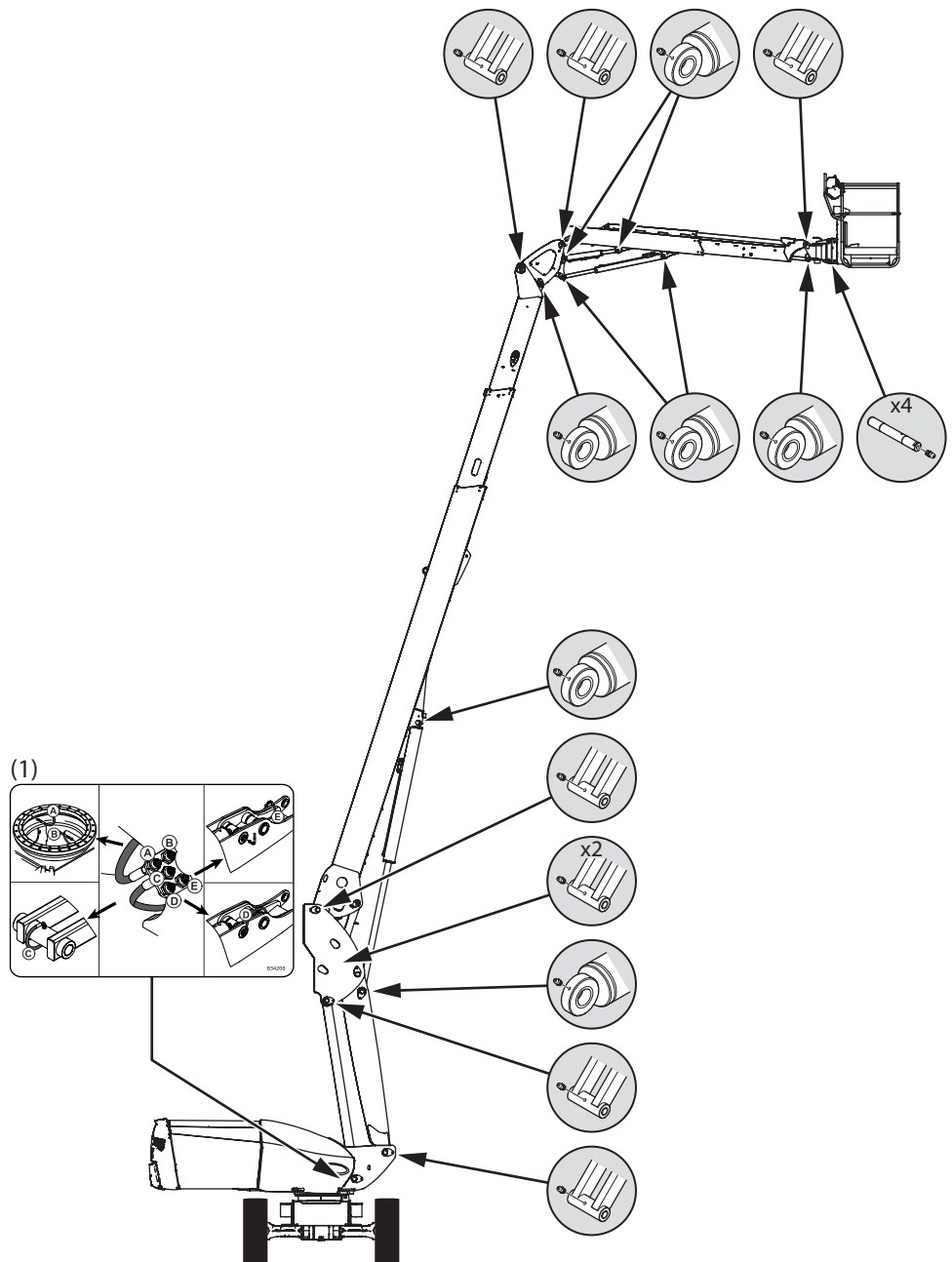
HUB

CYLINDER RING

<p>(1) ◀ 2 - DESCRIPTION: STICKERS: REMOTE LUBRICATION.</p> <p>Note: the lubricators are located under the left-hand turntable cover.</p> <p>Note: Ⓐ and Ⓑ, ◀ LUBRICATE: RING GEAR.</p>



⚠ IMPORTANT ⚠

Lubricate the telescopic arm more often when the machine is operating in a dusty environment.

Note: the diesel engine has been started. The left-hand turntable cover is open.

- Raise the jib arm to the horizontal position.
- Fully extend the telescopic arm.
- Check the sliding surfaces **A** and **B** of the pads:
 - Surfaces must be smooth and free from corrosion.
- Lubricate the telescopic arm if necessary,  LUBRICANTS, COOLANT AND FUEL.

Note: extend and retract the telescopic arm several times to spread the lubricant.
Remove the excess with a clean cloth.

- Fully retract the telescopic arm.
- 260 TJ+: fully lower the jib arm.

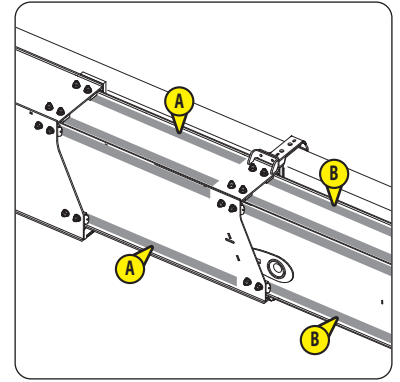

⚠ IMPORTANT ⚠

Lubricate the telescopic jib arm more often when the machine is operating in a dusty environment.

Note: the diesel engine has been started. The jib arm is raised and horizontal. The left-hand turntable cover is open.

- Fully extend the telescopic jib arm.
- Check the sliding surfaces **A** of the pads:
 - Surfaces must be smooth and free from corrosion.
- Lubricate the telescopic jib arm if necessary,  LUBRICANTS, COOLANT AND FUEL.

Note: extend and retract the telescopic jib arm several times to spread the lubricant. Remove the excess with a clean cloth.

- Fully retract the telescopic jib arm.
- Fully lower the jib arm.

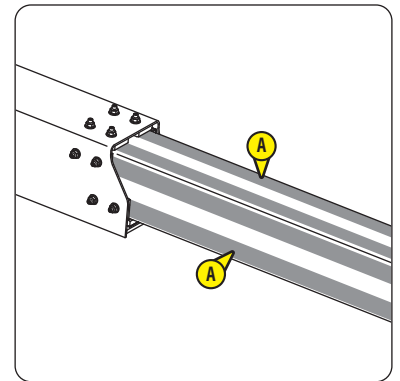



LUBRICATE

Crown gear

Note: the diesel engine has been started. The left-hand turntable cover is open.

- Remove the caps from the 2 lubrication connectors **A** and **B**.

Note:  2 - DESCRIPTION: STICKERS: REMOTE LUBRICATION **C**.

- Inject lubricant into the 2 lubrication connectors,  LUBRICANTS, COOLANT AND FUEL.
- Turn the turntable 90° to the left or the right and inject lubricant again.
- Refit the caps of the lubrication connectors.
- Close the left-hand turntable cover.
- Lubricate the teeth of the crown gear **1**,  LUBRICANTS, COOLANT AND FUEL.
- Turn the turntable a full turn to spread the lubricant.
- Put the turntable in neutral position.
- Switch off the machine.

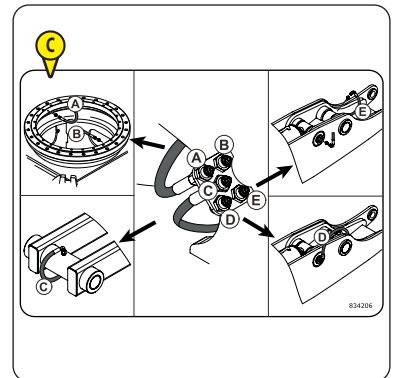
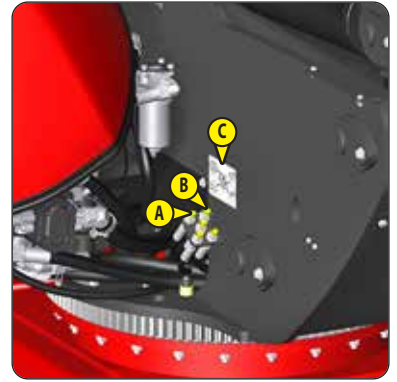

⚠ IMPORTANT ⚠***No flames or sparks. Do not smoke during this maintenance.***

Note: this maintenance is intended to remove dirt and water that may be present in the bottom of the fuel tank, the fuel tank does not need to be completely drained.

- Open the right-hand turntable cover.
- Locate the drain plug ① under the fuel tank and put a drain pan underneath.
- Remove the drain plug.
- Open the fuel flap ②.
- Remove the cap from the tank ③.
- Refit the drain plug when clean fuel flows.
- Clean around the drain plug with a clean cloth.
- Fill the fuel tank completely with clean fuel, \triangleleft DAILY MAINTENANCE: CHECK FUEL LEVEL.
- Refit the tank cap.
- Close the fuel flap.
- Bleed the fuel supply circuit \triangleleft OCCASIONAL MAINTENANCE.
- Check for fuel leaks from the drain plug.
- Close the right-hand turntable cover.
- Switch off the machine.

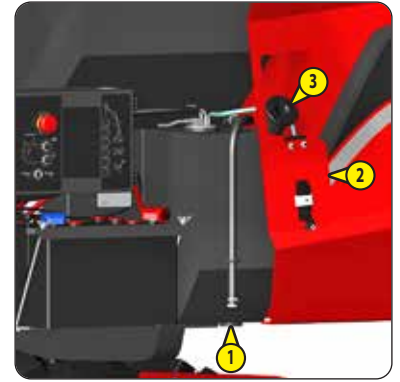
**RESET****Maintenance warning**

- Switch on the machine.
- Access the maintenance menu on the ground level display screen.
- Reset the maintenance warning.
- Return to the work page.
- Switch off the machine.

🔄 500H - PERIODIC MAINTENANCE - EVERY 500 HOURS OF SERVICE OR 1 YEAR

ALSO PERFORM THE DAILY SERVICE AND THE PERIODIC SERVICE AT 250 HOURS OF SERVICE.

CHECK

Tilt sensor

⚠️ IMPORTANT ⚠️

Failure to follow this instruction may result in the machine tipping over.

The machine must be in transport position with the turntable and the platform in neutral position and with the jib arm fully lowered.

- Start the diesel engine.
- Place the machine on a level surface.
- Access the "tilt calibration" menu on the ground level display screen.
- Check that the value displayed is $0^\circ \pm 0.3^\circ$.
- If the value is within the tolerances: return to the work page.
- If the value is outside the tolerances: refer to the machine repair manual to calibrate the tilt sensor.

CHECK

Tightening of the platform fixing screws

⚠️ IMPORTANT ⚠️

Failure to follow this instruction may result in the platform falling.

Always secure the raised jib arm using a suitable lifting device.

Note: the diesel engine has been started.

- Raise the jib arm and secure it using a suitable lifting device.
- Check the tightening torques of all the fixing screws ①:
 - $69 \text{ N.m} \pm 13.5 \text{ N.m}$
- Fully lower the jib arm.
- Switch off the machine.
- Take off the cover ②.
- Check the tightening torques of all the fixing screws ③:
 - $69 \text{ N.m} \pm 13.5 \text{ N.m}$
- Put the cover ② back in place.

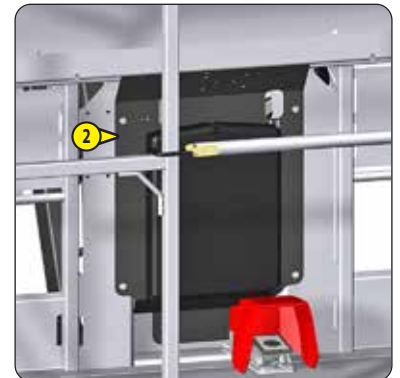

CHECK

Tightening of the platform rotation cylinder fixing screws

⚠ IMPORTANT ⚠

Failure to follow this instruction may result in the platform falling.

- Check the tightening torques of all the fixing screws ①:
 - 76 N.m \pm 15 N.m
- Check the tightening torque of the pin ②:
 - 80 N.m \pm 16 N.m



⚠ IMPORTANT ⚠

It is recommended that the telescopic jib arm chocking is adjusted if the clearances are greater than the maximum values. Refer to the machine's repair manual.

Note: the illustration shows a standard platform without gate.

- Check the tightening torques of all the nuts **1**:
 - 69 N.m ±6.5 N.m
- Start the diesel engine.
- Raise the jib arm slightly.
- Extend the telescopic jib arm for 1 second.
- Check the clearances between the pads and the telescopic jib arm **2**:
 - **A** (upper pad **3**) should be between 1 mm and 1.5 mm.
 - **B** (side pads **4**) must be between 0.5 mm and 0.75 mm on either side.
- Fully extend the telescopic jib arm.

Note: ensure that the platform cannot hit the ground. Raise the jib arm again if required.

- Check the clearances **A** and **B** again.
- Fully retract the telescopic jib arm.
- Take off the cover **5**.
- Place several wooden pallets under the platform.
- Slowly lower the jib arm until the pads **6** are in contact with the telescopic jib arm **2**.
- Check the clearances between the pads and the jib arm:
 - **C** (upper pads **7**) must be between 1 mm and 1.5 mm.
 - **D** (side pads **8**) must be between 0.5 mm and 0.75 mm on either side.
- Raise the jib arm slightly.
- Remove the wooden pallets.
- Put the cover **5** back in place.

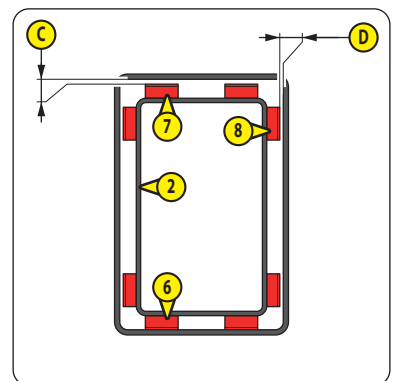
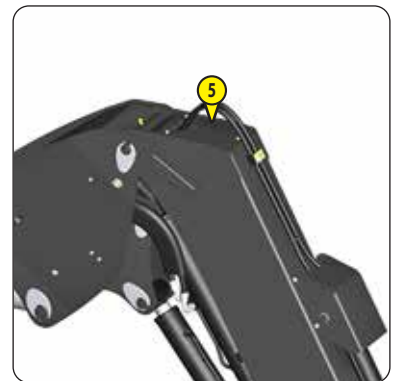
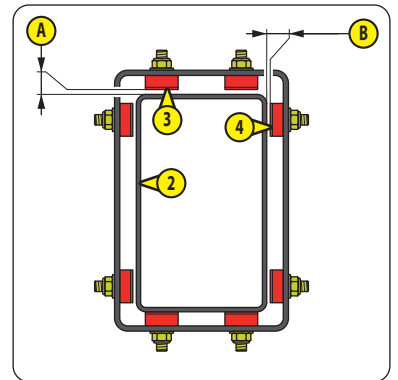
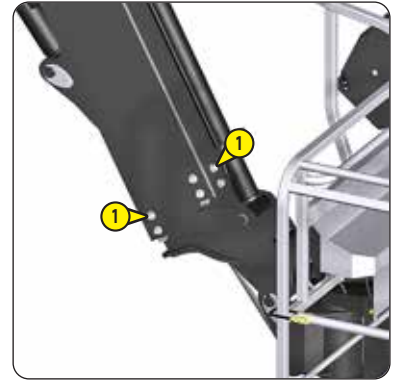

⚠ IMPORTANT ⚠

It is recommended that the telescopic arm chocking is adjusted if the clearances are greater than the maximum values.

Refer to the machine's repair manual.

Always secure the raised jib arm using a suitable lifting device.

Note: 280 TJ, the diesel engine has been started. The jib arm is slightly raised.

- Check the tightening torques of all the nuts **1**:
 - 69 N.m ±6.5 N.m
- 260 TJ+: start the diesel engine.
- 260 TJ+: raise the jib arm slightly.
- Extend the telescopic arm for 1 second.
- Check the clearances between the pads and the intermediate telescopic arm **2**:
 - **A** (upper pad **3**) should be between 1 mm and 1.5 mm.
 - **B** (side pads **4**) must be between 0.5 mm and 0.75 mm on either side.
- Check the clearances between the pads and the telescopic arm **5**:
 - **C** (upper pad **6**) should be between 1 mm and 1.5 mm.
 - **D** (side pads **7**) must be between 0.5 mm and 0.75 mm on either side.
- Fully extend the telescopic arm.

Note: ensure that the platform cannot hit the ground. Raise the jib arm again if required.

- Check the clearances **A**, **B**, **C** and **D** again.
- Fully retract the telescopic arm.
- Fully lower the jib arm.
- Take off the cover **8**.
- Raise the main arm slightly.
- Place several wooden pallets under the platform.
- Slowly lower the main arm until the pads **9** are in contact with the intermediate telescopic arm. **2**
- Check the clearances between the pads and the main arm:
 - **E** (upper pads **11**) must be between 1 mm and 1.5 mm.
 - **F** (side pads **12**) must be between 0.5 mm and 0.75 mm on either side.
- Check the clearances between the pads and the intermediate telescopic arm **2**:
 - **G** (upper pad **13**) should be between 1 mm and 1.5 mm.
 - **H** (side pads **14**) must be between 0.5 mm and 0.75 mm on either side.
- Raise the main arm slightly.
- Remove the wooden pallets.
- Fully lower the main arm.
- Switch off the machine.

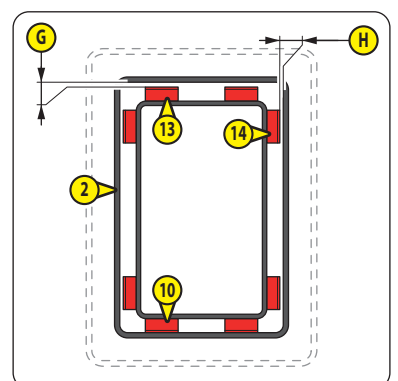
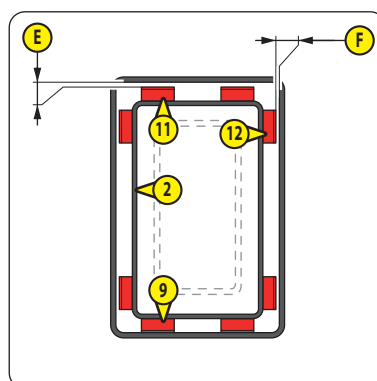
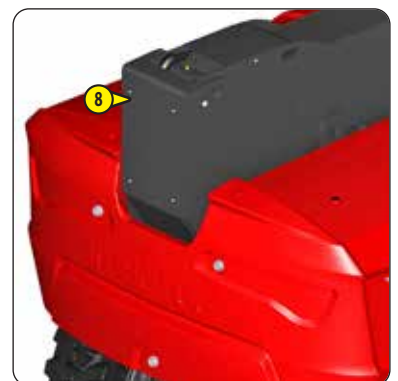
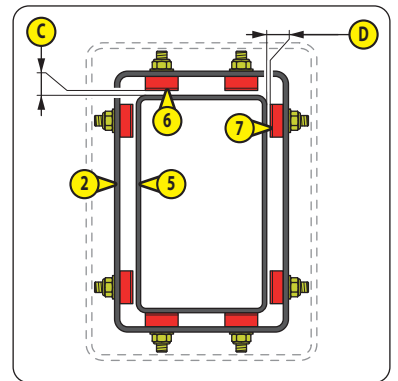
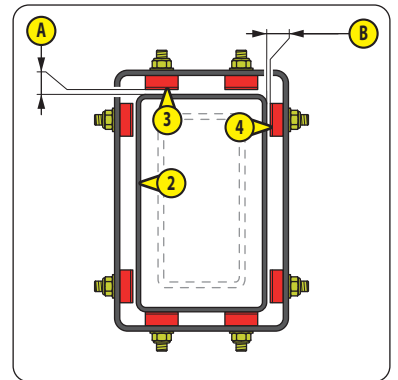
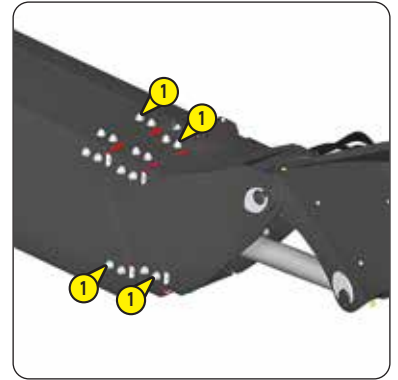

CHECK

Tightening of the fixing screws on the telescopic arm cylinder

⚠ IMPORTANT ⚠

Failure to follow this instruction may result in involuntary movement of the telescopic arm.

Note: the cover **2** is removed.

- Check the tightening torques of all the fixing screws **1**:
 - 44 N.m ±8.5 N.m
- Put the cover **2** back in place.

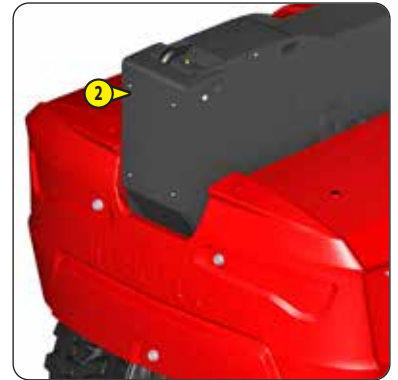
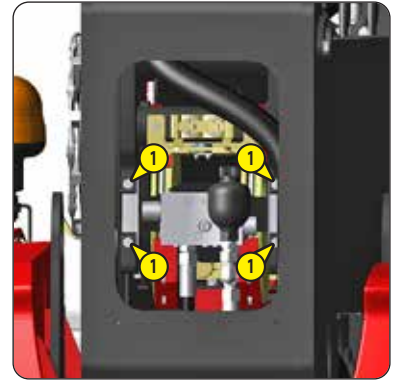

CHECK

Tightening of the fixing screws for the crown gear

⚠ IMPORTANT ⚠

Failure to follow this instruction may result in the machine tipping over.

If one or more screws are loose, replace them with new screws and tighten them to torque.

Note: the illustration shows a 260 TJ+.

- Open the left-hand turntable cover.
- Locate the drill hole **A**.
- Open the right-hand turntable cover.
- Locate the drill hole **B**.
- Start the diesel engine.
- Turn the turntable to align the drill holes **A** and **B** with 2 fixing screws **1**.
- Check the tightening torques of the first 2 fixing screws **1**:
 - 145 N.m ±14.5 N.m
- Turn the turntable to align the holes **A** and **B** with the next 2 fixing screws **1** and check their tightening torques.
- Repeat the steps until the tightening torque for each fixing screw **1** has been checked.
- Put the turntable in neutral position.
- Switch off the machine.
- Open the swiveling engine support, ⚠ OCCASIONAL OPERATIONS.
- Check the tightening torques of the fixing screws **2**:
 - 145 N.m ±14.5 N.m

Note: the fastening screws **2** are protected by a plastic cap.

- Close the swiveling engine support, ⚠ OCCASIONAL OPERATIONS.

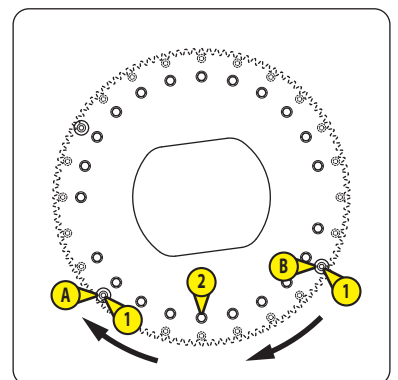
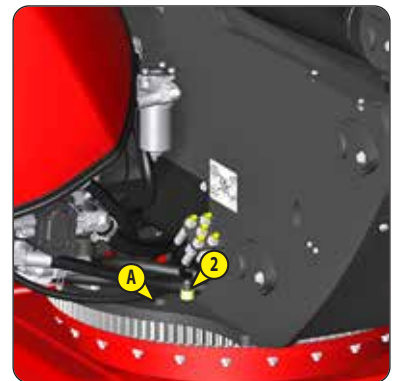

CHECK

Tightening of the fixing screws on the turntable rotation motor

⚠ IMPORTANT ⚠

Failure to follow this instruction may result in involuntary movement of the turntable.

Note: the illustration shows a 260 TJ+.

Note: the right and left turntable covers are open.

- Check the tightening torques of all the fixing screws:
 - ① = 192 N.m ±38 N.m
 - ② = 341 N.m ±68 N.m
- Close the left and right-hand turntable covers.

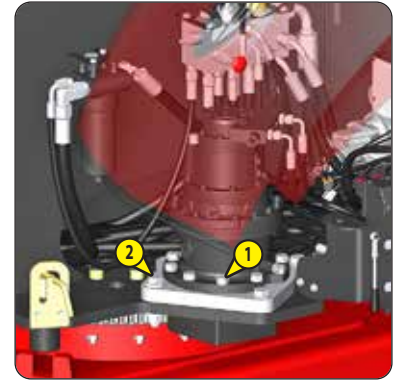

CHECK

Tightening of cast iron counterweight fixing screws

⚠ IMPORTANT ⚠

Failure to follow this instruction may result in the machine tipping over.

- Check the tightening torques of all the fixing screws ①:
 - 341 N.m ±68 N.m



CHECK

Tightening of concrete counterweight fixing screws

⚠ IMPORTANT ⚠

*Failure to follow this instruction may result in the machine tipping over.
Always secure the raised main arm with a suitable lifting device.*

Note: the left and right chassis covers have been removed.

- Start the diesel engine.
- Raise the main arm as far as possible and secure it using a suitable lifting device.
- Switch off the machine.
- Check the tightening torques of all the fixing screws ①, on the left and right-hand sides:
 - 341 N.m ±68 N.m

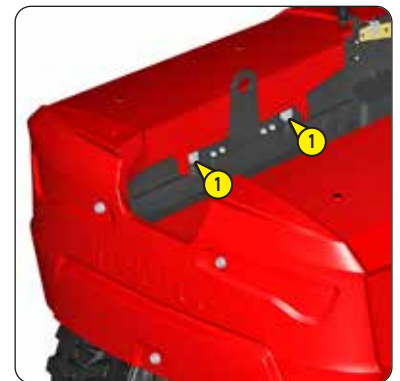

CHECK

Tightening of the fixing screws for the lifting points

⚠ IMPORTANT ⚠

*Failure to apply this instruction may result in the machine falling during lifting.
Always secure the raised main arm with a suitable lifting device.*

Note: the main arm is raised and secured.

- Check the tightening torques of all the fixing screws **①**, on the left and right-hand sides:
 - 256 N.m ±25 N.m

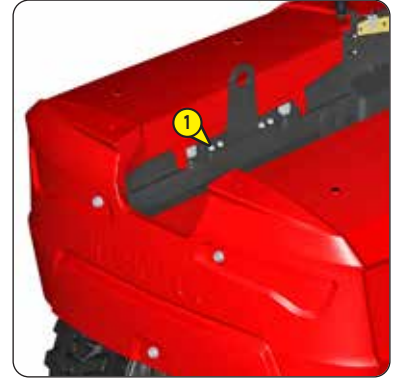

CHECK

Hydraulic hoses

⚠ IMPORTANT ⚠

*Always use a piece of paper or cardboard to check there are no hydraulic oil leaks.
Replace any damaged hydraulic hoses.
Always secure the raised main arm with a suitable lifting device.*

Note: the main arm is raised and secured.

- Open the left and right-hand turntable covers.
- Remove the right-hand and left-hand chassis covers.
- Remove the front and rear chassis covers.
- Open the swiveling engine support, \triangleleft OCCASIONAL OPERATIONS.
- Check the condition of all the hydraulic hoses and that there are no oil leaks.
- Refit the front and rear chassis covers.
- Refit the right-hand and left-hand chassis covers.
- Close the swiveling engine support, \triangleleft OCCASIONAL OPERATIONS.
- Start the diesel engine.
- Fully lower the main arm.
- Switch off the machine.
- Check the condition of all the other hydraulic hoses and check that there are no oil leaks.

⚠ IMPORTANT ⚠

*Wait until the diesel engine cools if it has been running for a while.
 No flames or sparks. Do not smoke during this maintenance.
 Never use the machine without the water separator filter cartridge or if it is damaged.*

Note: the right and left turntable covers are open.

- Clean the outside of the water separator **1** with a clean cloth and put a drain pan underneath.
- Turn the tap **2** to the OFF position "OFF".
- Unscrew the bleed valve **3**.
- Loosen the bleed screw **4** by 2 or 3 turns.
- Do the bleed valve **3** back up by hand (tightening torque = 1.5 N.m ±0.5 N.m) when the tank **5** is empty.
- Do the bleed screw **4** back up.
- Replace the water separator filter cartridge, **⇐ FILTER CARTRIDGES AND BELTS**:
 - Unscrew the tank **5** and remove it. Take care as the used water separator filter cartridge could fall out.
 - Remove the used water separator filter cartridge.
 - Clean the tank with clean fuel, **⇐ LUBRICANTS, COOLANT AND FUEL**.
 - Check its condition. Replace it if necessary.
 - Check the condition of the tank seal. Replace it if necessary.
 - Check the condition of the float **6**. Replace it if necessary.
 - Put the new water separator filter cartridge in place.
 - Put the float back in the tank.
 - Do the tank back up by hand (tightening torque = 30 N.m ±3 N.m).
- Check the condition of the fuel hoses and the hose clamps. Replace them if necessary.

Note: replace the fuel filter element after this service, see next page.

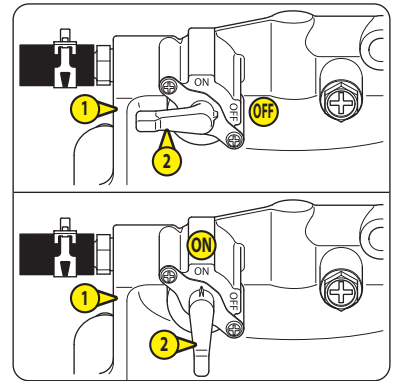
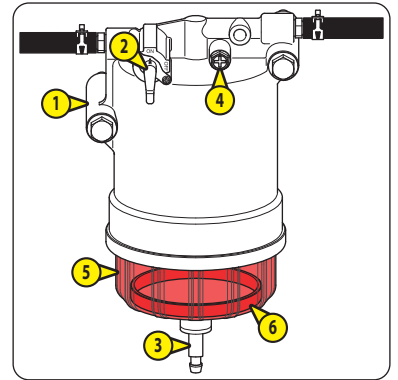
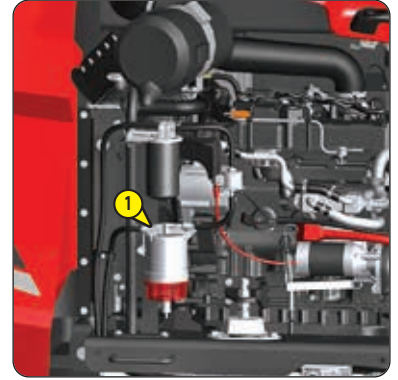

⚠ IMPORTANT ⚠

*No flames or sparks. Do not smoke during this maintenance.
Never use the machine without the fuel filter cartridge or if it is damaged.*

Note: the right and left turntable covers are open. The valve ② of the water separator ① is in the OFF position "OFF". The water separator filter cartridge has been replaced, see previous page.

- Clean the outside of the fuel filter ③ with a clean cloth and place a drain pan underneath.
- Replace the fuel filter cartridge, FILTER CARTRIDGES AND BELTS:
 - Remove the used fuel filter cartridge.
 - Lubricate the seal of the new fuel filter cartridge with clean fuel, LUBRICANTS, COOLANT AND FUEL.
 - Screw in the new fuel filter cartridge by hand until it makes contact with the mounting surface.
 - Tighten it by one turn using a filter wrench (tightening torque = 22 N.m ± 2 N.m).
- Check the condition of the fuel hoses and the hose clamps. Replace them if necessary.
- Bleed the fuel supply circuit, OCCASIONAL MAINTENANCE.
- Check for fuel leaks from the water separator and the fuel filter.
- Switch off the machine.

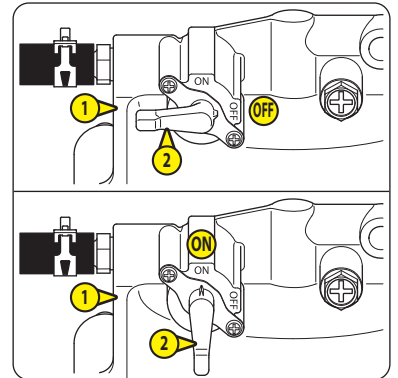
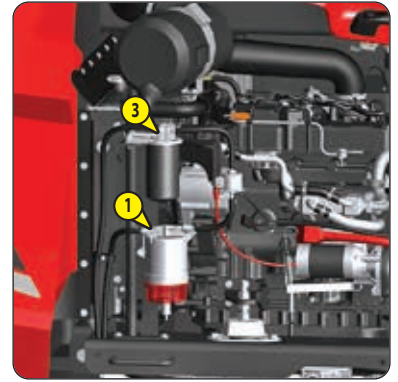

⚠ IMPORTANT ⚠

Never use the machine with a damaged air filter unit. If there is doubt about its condition, have it replaced by an approved professional from the Manitou network.

Never use the machine without the outside air filter cartridge or if it is damaged.

Never use the machine without the inside air filter cartridge or if it is damaged. If there is doubt about its condition,

⚠ ⌚ 1000H: REPLACE: INSIDE AIR FILTER CARTRIDGE.

If there is doubt about the condition of the air intake line, the air suction outlet hose and hose clamps,

⚠ ⌚ 1000H: REPLACE: AIR INTAKE LINE AND AIR SUCTION OUTLET HOSE.

Note: the right and left turntable covers are open.

- Clean the outside of the air filter unit ① with a clean, slightly damp cloth.
- Unlock and remove the cover ②.
- Clean the inside of the cover with a clean, slightly damp cloth.
- Remove the valve ③ and clean it with a clean, slightly damp cloth.
- Check the condition and replace it if it is damaged.
- Put the valve back in place.
- Remove the used outside air filter cartridge ④, pulling it gently to prevent dust dispersion.

Note: do not press the center of the outside air filter cartridge.

- Check the condition of the inside air filter cartridge ⑤ without taking it out.
- Check the condition of the air filter unit, the air intake line, the air suction outlet hose and the tightening clamps.
- Replace the outside air filter cartridge ④, ⚠ FILTER CARTRIDGES AND BELTS:
 - Clean the seal of the new outside air filter cartridge with a clean cloth.
 - Put the new outside air filter cartridge in place by pushing it gently.

Note: do not press the center of the outside air filter cartridge.

- Refit the cover ②, with the valve ③ facing downward and the marking "TOP" facing upward.

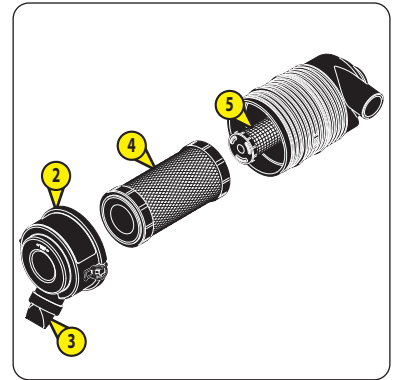
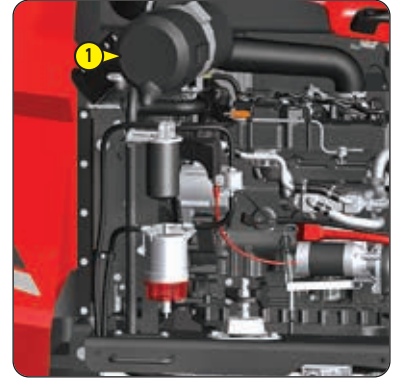

REPLACE

Turntable rotation motor oil

⚠ IMPORTANT ⚠

It is recommended that the oil is slightly warm before being changed.

Note: the illustration shows a 260 TJ+.

Note: the right and left turntable covers are open.

- Clean the outside of the turntable rotation motor ① with a clean cloth.
- Check for oil leaks.

DRAIN THE OIL

- Place a drain pan under the drain plug ②.
- Remove the drain plug and the filler cap ③.
- Wait until the crankcase is completely empty.

FILL THE TURNTABLE ROTATION MOTOR

- Clean around the drain hole with a clean cloth.
- Refit the drain plug.
- Fill the turntable rotation motor with new oil, LUBRICANTS, COOLANT AND FUEL.
- Clean the dipstick on the filler cap with a clean cloth and put it back in place.
- Remove the filler cap. The level is correct when the oil is between the 2 marks A and B.
- If the level is low, add oil until the correct level is reached, LUBRICANTS, COOLANT AND FUEL.
- Refit the filler cap.

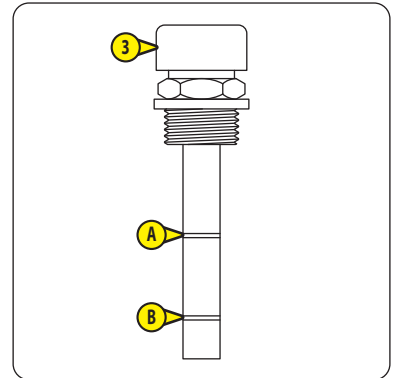
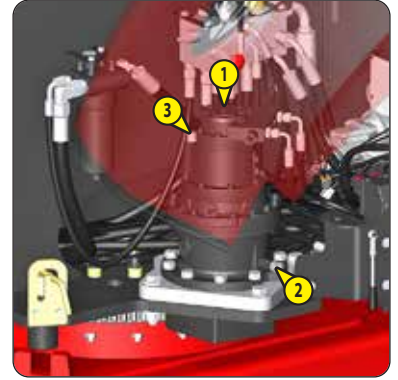

REPLACE

Hydraulic pressure filter cartridge

⚠ IMPORTANT ⚠

Never use the machine without the hydraulic pressure filter cartridge or if it is damaged.

Note: the illustration shows a 260 TJ+.

Note: the right and left turntable covers are open.

- Clean the outside of the hydraulic pressure filter ① with a clean cloth.
- Place a drain pan underneath.
- Replace the hydraulic pressure filter cartridge ②, FILTER CARTRIDGES AND BELTS:
 - Unscrew the hydraulic pressure filter tank ③.
 - Remove the used hydraulic pressure filter cartridge.
 - Put the new hydraulic pressure filter cartridge in place.
 - Screw up the hydraulic pressure filter tank.
- Start the diesel engine.
- Lift/lower the main arm and the jib arm for several minutes.
- Fully lower the main arm and the jib arm.
- Check for oil leaks from the hydraulic pressure filter.
- Close the right-hand turntable cover.
- Switch off the machine.

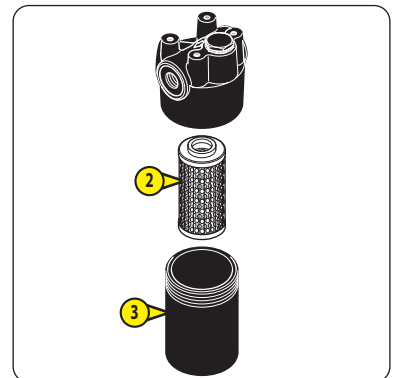
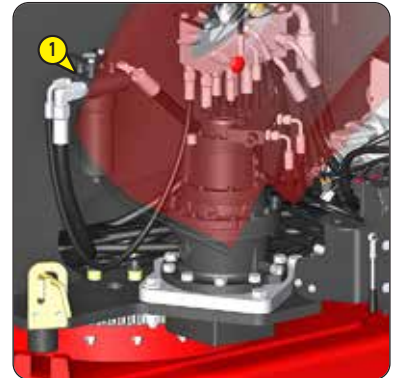



REPLACE

Hydrostatic transmission filter cartridge

⚠ IMPORTANT ⚠

Never use the machine without the hydrostatic transmission filter cartridge or if it is damaged.

Note: the left-hand turntable cover is open.

- Clean the outside of the hydrostatic transmission filter **1** with a clean cloth.
- Place a drain pan underneath.
- Replace the hydrostatic transmission filter cartridge **2**,  FILTER CARTRIDGES AND BELTS:
 - Unscrew the hydrostatic transmission filter tank **3**.
 - Remove the used hydrostatic transmission filter cartridge.
 - Put the new hydrostatic transmission filter cartridge in place.
 - Do the hydrostatic transmission filter tank back up.
- Close the left-hand turntable cover.
- Start the diesel engine.
- Drive the machine forward and backward for several minutes.
- Open the left-hand turntable cover.
- Check for oil leaks from the hydrostatic transmission filter.
- Check the hydraulic oil level,  DAILY MAINTENANCE: CHECK THE HYDRAULIC OIL LEVEL.
- Close the left-hand turntable cover.
- Switch off the machine.

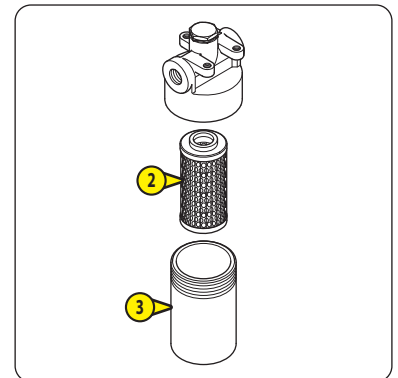
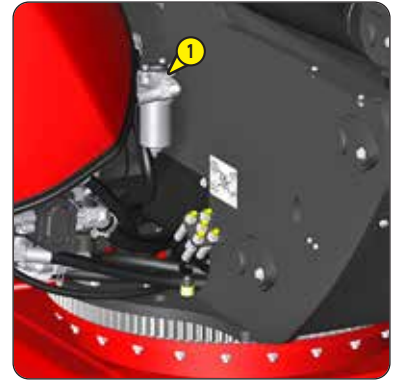

RESET

Maintenance warning

-   250H: RESET: MAINTENANCE WARNING.

➔ ③ 1000H - PERIODIC MAINTENANCE - EVERY 1000 HOURS OF SERVICE OR 2 YEARS

ALSO PERFORM THE DAILY SERVICE AND THE PERIODIC SERVICES AT 250 HOURS AND 500 HOURS OF SERVICE.

REPLACE

Inside air filter cartridge

⚠ IMPORTANT ⚠

Never use the machine without the inside air filter cartridge or if it is damaged.

- Open the left-hand turntable cover.
 - Perform the procedure described in ➔ ② 500H: REPLACE THE OUTSIDE AIR FILTER CARTRIDGE and replace the inside air filter cartridge ⑤, ◀ FILTER CARTRIDGES AND BELTS:
 - Remove the used inside air filter cartridge, pulling it gently to prevent dust dispersion.
 - Block the outlet of the air filter unit with a clean cloth.
 - Clean the inside of the air filter unit with a clean, slightly damp cloth.
 - Remove the cloth from the air filter unit outlet.
 - Clean the seal of the new inside air filter cartridge with a clean cloth.
 - Put the new inside air filter safety cartridge in place by pushing it gently.
- Note: do not press the center of the inside air filter cartridge.

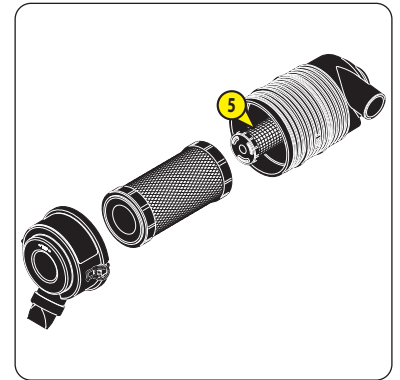

REPLACE

Coolant

⚠ IMPORTANT ⚠

*Wait until the diesel engine cools if it has been running for a while.
Do not remove the radiator cap until the diesel engine is completely cooled.*

Note: the left-hand turntable cover is open.

DRAIN THE COOLANT

- Open the swiveling engine support, ◀ OCCASIONAL OPERATIONS.
- Locate the drain plug ① under the coolant radiator and put a drain pan underneath.
- Locate the hose ② to the left of the diesel engine oil filter and place a drain pan underneath.
- Remove the drain plug, the hose and the radiator cap ③.
- Wait until the cooling circuit is completely empty.

FILL THE COOLING CIRCUIT

- Clean around the drain hole with a clean cloth.
- Refit the hose and the drain plug.
- Fill the cooling circuit with new coolant, ◀ LUBRICANTS, COOLANT AND FUEL. The level is correct when the coolant reaches the top of the filling hole.
- Refit the radiator cap.
- Start the diesel engine.
- Allow it to idle for 5 minutes.
- Check for coolant leaks from the drain plug.
- Switch off the machine.
- Wait until the diesel engine cools.
- Remove the radiator plug .
- Check the coolant level and top up if necessary.
- Refit the radiator cap.

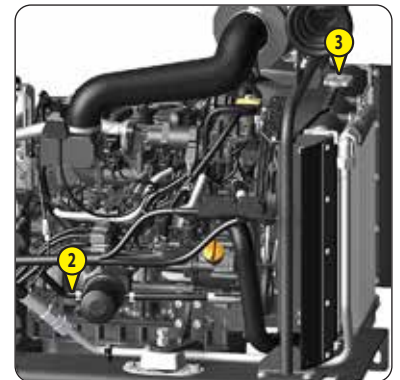
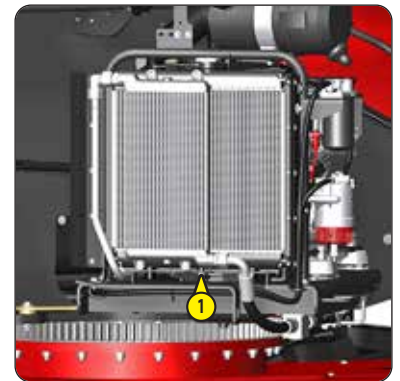

REPLACE

Diesel engine oil

REPLACE

Diesel engine oil filter

Note: the left-hand turntable cover is open. The swiveling engine support plate is open.

CHANGE THE OIL

- Start the diesel engine.
- Allow it to idle for 5 minutes.
- Switch off the machine.
- Locate the drain plug **1** and put a drain pan underneath.
- Remove the drain plug and the filler cap **2**.
- Wait until the crankcase is completely empty.

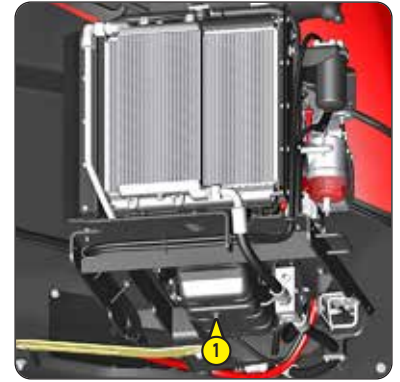

REPLACE THE DIESEL ENGINE OIL FILTER

- Place a drain pan under the diesel engine oil filter **3**.
- Replace the diesel engine oil filter, **FILTER CARTRIDGES AND BELTS:**
 - Unscrew the used diesel engine oil filter.
 - Lubricate the seal of the new diesel engine oil filter with clean diesel engine oil, **LUBRICANTS, COOLANT AND FUEL.**
 - Screw in the new diesel engine oil filter by hand until it touches the mounting surface.
 - Tighten it by one turn using a filter wrench (tightening torque = 21.5 N.m ± 2 N.m).

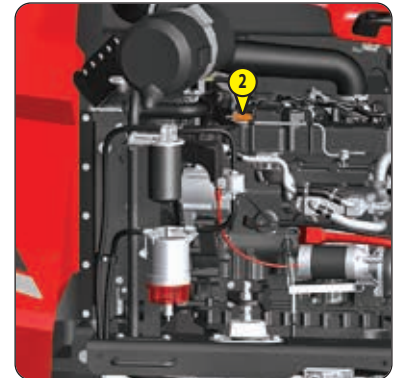

FILL THE DIESEL ENGINE

- Clean around the drain hole with a clean cloth.
- Refit the drain plug.
- Fill the diesel engine with new diesel engine oil, **LUBRICANTS, COOLANT AND FUEL.**
- Wait 5 minutes for the oil to settle in the crankcase.
- Refit the filler cap.
- Check the diesel engine oil level, **DAILY MAINTENANCE: CHECK DIESEL ENGINE OIL LEVEL.**
- Start the diesel engine.
- Allow it to idle for 5 minutes.
- Check for oil leaks from the drain plug and the diesel engine oil filter.
- Close the swiveling engine support, **OCCASIONAL OPERATIONS.**
- Switch off the machine.
- Wait 5 minutes for the oil to settle in the crankcase.
- Check the diesel engine oil level again and top up if necessary, **DAILY MAINTENANCE: CHECK DIESEL ENGINE OIL LEVEL.**
- Close the left-hand turntable cover.



REPLACE

Reduction gearbox oil

⚠ IMPORTANT ⚠

It is recommended that the oil is slightly warm before being changed.

CHANGE THE OIL

- Locate the reduction gearbox ① on the rear axle.
- Clean the outside of the reduction gearbox with a clean cloth.
- Place a drain pan under the drain plug ②.
- Remove the drain plug and one of the filler plugs ③.

Note: 2 filler caps, left and right sides.

- Wait until the reduction gearbox is completely empty.

FILL THE ENGINE REDUCTION GEARBOX

- Clean around the drain hole with a clean cloth.
- Refit the drain plug.
- Fill the reduction gearbox with new oil, ⚠ LUBRICANTS, COOLANT AND FUEL. The level is correct when the oil reaches the rim of the filling hole.
- Refit the filler cap.

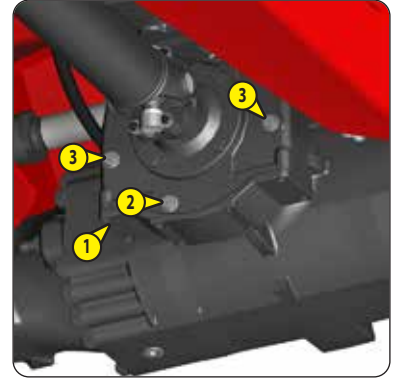

REPLACE

Front and rear axle differential oil

⚠ IMPORTANT ⚠

It is recommended that the oil is slightly warm before being changed.

Note: replace the oil in the axle differentials one by one.

CHANGE THE OIL

- Clean the outside of the axle differential with a clean cloth.
- Front axle: place a drain pan under the drain plug ①.
- Rear axle: place a drain pan under the 3 drain plugs ①.
- Remove the drain plug(s) and the filler plug ②.
- Wait until the axle differential is completely empty.

FILL THE AXLE DIFFERENTIAL

- Clean around the drain hole(s) with a clean cloth.
- Front axle: refit the drain plug.
- Rear axle: refit the 3 drain plugs.
- Fill the axle differential with new oil, ⚠ LUBRICANTS, COOLANT AND FUEL. The level is correct when the oil reaches the rim of the filling hole.
- Refit the filler cap.

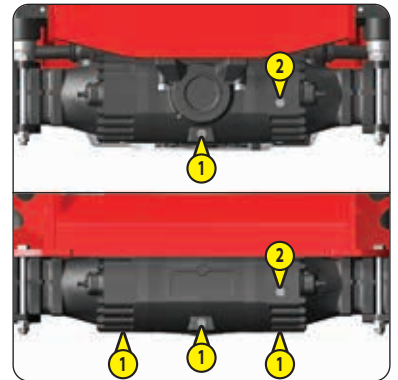

REPLACE

Front and rear wheel reduction gear oil

⚠ IMPORTANT ⚠

It is recommended that the oil is slightly warm before being changed.

Note: replace the oil in the wheel reduction gears one by one.

CHANGE THE OIL

- Clean the outside of the wheel reduction gear with a clean cloth.
- Turn the wheel to put the drain/filler plug ① in position ②.
- Place a drain pan underneath.
- Remove the drain/filler plug .
- Wait until the wheel reduction gear is completely empty.

FILL THE WHEEL REDUCTION GEAR

- Clean around the drain/filler hole with a clean cloth.
- Turn the wheel to put the drain/filler hole ① in position ③.
- Fill the wheel reduction gear with new oil, <⚠ LUBRICANTS, COOLANT AND FUEL.
- The level is correct when the oil reaches the rim of the filling hole.
- Refit the drain/filler plug:
 - Tightening torque = $42 \text{ N.m} \pm 7 \text{ N.m}$

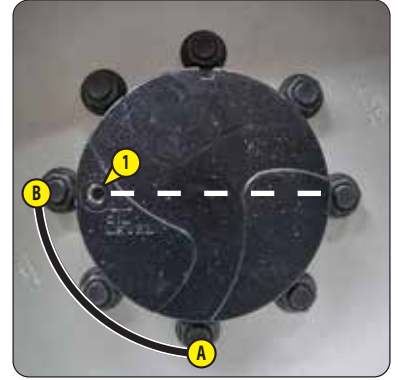

⚠ IMPORTANT ⚠

It is recommended that the oil is slightly warm before being changed.

There can be a difference in level between hot and cold oil. It is recommended the level is checked again when the hydraulic oil is hot.

Clean the oil can before adding oil to the hydraulic oil tank.

Use a clean funnel to add oil to the hydraulic oil tank.

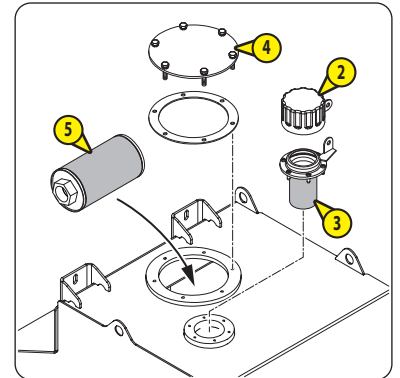
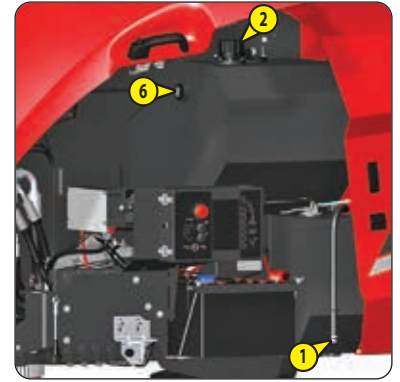
**CHANGE THE OIL**

- Open the right-hand turntable cover.
- Locate the drain plug ① and put a drain pan underneath.
- Remove the drain plug and the tank plug ②.
- Wait until the tank is completely empty.

CLEAN THE FILLING FILTER AND SUCTION STRAINER

- Remove the filling filter ③.
- Clean it with compressed air, from the outside in:
 - Maximum pressure = 3 bars. Minimum distance = 30 mm.
- Check its condition. Replace it if necessary, FILTER CARTRIDGES AND BELTS.
- Take off the cover ④.
- Remove the suction strainer ⑤ located inside the tank.
- Clean the suction strainer with compressed air, from the inside out:
 - Maximum pressure = 3 bars. Minimum distance = 30 mm.
- Check its condition. Replace it if necessary, FILTER CARTRIDGES AND BELTS.
- Check that there is no debris or dust in the bottom of the tank. Clean it if necessary.
- Refit the filling filter.
- Put the suction strainer and the cover back in place.

FILL THE HYDRAULIC OIL TANK

- Refit the drain plug.
- Fill the tank with new hydraulic oil, LUBRICANTS, COOLANT AND FUEL. The level is correct when the oil reaches the red dot on the level indicator ⑥.
- Refit the tank cap.
- Start the diesel engine.
- Activate the machine's functions for 10 minutes.
- Check for oil leaks from the drain plug.
- Place the machine in transport position.
- Put the turntable and platform in neutral position.
- Level the platform/jib arm.
- Fully lower the jib arm.
- Check the hydraulic oil level and top up if necessary.
- Close the right-hand turntable cover.
- Switch off the machine.

CHECK	<i>Diesel engine silent blocks *</i>
CHECK	<i>Diesel engine speeds *</i>
CHECK	<i>Hydrostatic transmission circuit pressure *</i>
CHECK	<i>Clearance of slewing ring gear *</i>
CHECK	<i>Condition of the telescopic arm cables *</i>
CHECK	<i>Speeds of hydraulic movements *</i>
CHECK	<i>Condition of cylinders *</i>
CHECK	<i>Condition of electric wiring *</i>
REPLACE	<i>Injection pipes, fuel hoses and the hose clamps *</i>
REPLACE	<i>Hoses and hose clamps for the coolant radiator *</i>
REPLACE	<i>Lubrication hoses *</i>
REPLACE	<i>Air intake line and air suction hose *</i>
RESET	<i>Maintenance warning</i>

↶ ⌚ 250H: RESET: MAINTENANCE WARNING.

**** Consult your dealer.***

➔ 4 1500H - PERIODIC MAINTENANCE - EVERY 1500 HOURS OF SERVICE OR 3 YEARS

CHECK *Air circulation system in the engine crankcase **

RESET *Maintenance warning*

⚠️ ➔ 1 250H: RESET: MAINTENANCE WARNING.

** Consult your dealer.*

➔ 5 2000H - PERIODIC MAINTENANCE - EVERY 2000 HOURS OF SERVICE OR 4 YEARS

CHECK *Coolant and oil radiators **

CHECK *Clearance of valve seats **

CHECK *Hydraulic circuit pressures **

RESET *Maintenance warning*

⚠️ ➔ 1 250H: RESET: MAINTENANCE WARNING.

** Consult your dealer.*

➔ 6 3000H - PERIODIC MAINTENANCE - EVERY 3000 HOURS OF SERVICE OR 6 YEARS

CHECK *Engine ECU (ECU) and associated sensors and actuators **

CHECK *Diesel oxidation catalyst (DOC) of the diesel particulate filter (DPF) **

CHECK *Intake valve **

CHECK *Exhaust valve **

CHECK AND CLEAN *Exhaust gas recirculation system valve (EGR) **

CHECK AND CLEAN *Injectors **

CLEAN *Exhaust gas recirculation (EGR) system cooler **

RESET *Maintenance warning*

⚠️ ➔ 1 250H: RESET: MAINTENANCE WARNING.

** Consult your dealer.*

➔ 7 6000H - PERIODIC MAINTENANCE - EVERY 6000 HOURS OF SERVICE OR 12 YEARS

REPLACE *Telescopic arm cables **

** Consult your dealer.*

REPLACE

Wheels

⚠ IMPORTANT ⚠

⚠ 2 - DESCRIPTION: SPECIFICATIONS and refer to the applicable stickers for information about the total weight of the machine and wheel load.

When lifting the machine with a mechanical or hydraulic jack:

- Always use a suitable jack for lifting the machine.
- Make sure that the 2 wheels on the opposite side to the lift are chocked.
- Position the jack near the wheel to be raised.
- Always use suitable jack stands to secure the raised machine.

⚠ IMPORTANT ⚠

Weight of a wheel = 281 kg (620 lbs).

- Loosen the wheel nuts slightly.
- Lift the machine.
- Remove the wheel nuts and the wheel.
- Put the new wheel in place.
- Refit the wheel nuts and tighten them slightly with a spanner.
- Lower the machine to the ground.
- Tighten the wheel nuts, ⚠ ⇒ 250H: CHECK: WHEEL NUT TIGHTENING.



⚠ IMPORTANT ⚠

*Ensure that the machine is switched off.
Disconnect the battery before working on the electrical system.*

POWER CIRCUIT FUSES

- Open the right-hand turntable cover.
- Locate the fuse box **1**.
- Remove the cover of the fuse box.
- Replace the appropriate fuse:

A	Backup pump	250 A fuse
B	General electrical power supply	350 A fuse

Note: STICKERS: POWER FUSES **C**.

- Put the fuse box cover back in place.
- Close the right-hand turntable cover.

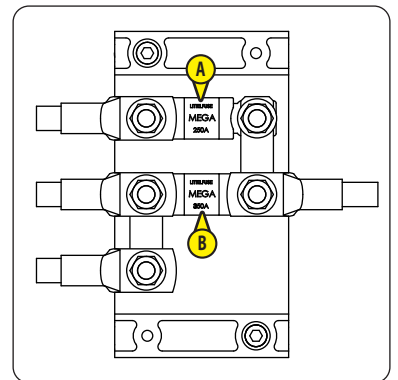
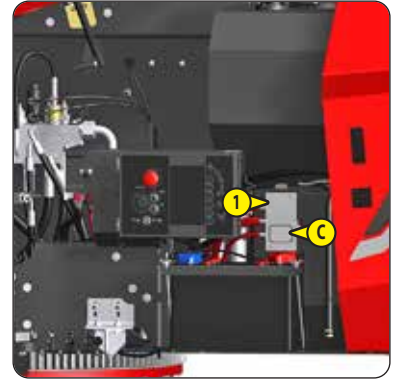

DIESEL ENGINE FUSES/RELAYS AND CONTROL SYSTEM

- Open the right-hand turntable cover.
- Locate the fuse/relay box **2**.
- Remove the cover of the fuse/relay box.
- Replace the appropriate fuse/relay:

F1	Ground level control panel	60 A fuse
F2	Diesel engine preheat	60 A fuse
F3	Diesel engine starter	80 A fuse
F4	Exhaust gas recirculation system valve (EGR)	20 A fuse
F5	Diesel engine	25 A fuse
F6	Not used	-
F7	Immobilizer (option)	1 A fuse
K1	Diesel engine preheat	12 V 40 A Relay
K2	Diesel engine preheat	12 V 40 A Relay
K3	Diesel engine starter	12 V 40 A Relay
K4	Exhaust gas recirculation system valve (EGR)	12 V 40 A Relay
K5	Not used	-

- Put the fuse/relay box cover back in place.
- Close the right-hand turntable cover.

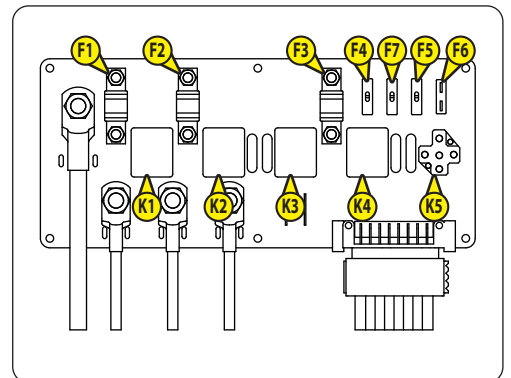

GROUND LEVEL CONTROL PANEL FUSES/RELAYS

- Open the right-hand turntable cover.
- Unlock and open the ground level control panel ③.
- Replace the appropriate fuse/relay:

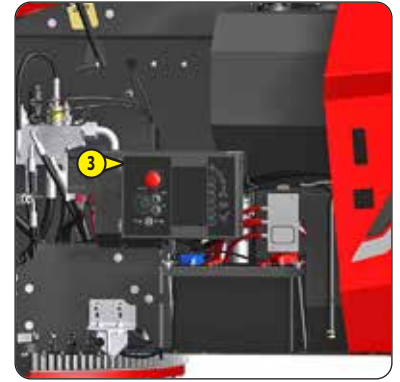

F1	Start button	5 A fuse
F2	Ground level display screen	5 A fuse
F3	Ground-level display screen and control panel in the platform	5 A fuse
F4	Worklight power supply (option)	5 A fuse
F5	Backup pump button	10 A fuse
F6	Ground level display screen	5 A fuse
F7	Key switch	10 A fuse
F8	Diesel engine power supply	30 A fuse
K1	Immobilizer (option)	12 V 35 A Relay
K2	Diesel engine stop	12 V 35 A Relay
K3	General electrical power supply	12 V 35 A Relay

- Close the ground level control panel.
- Close the right-hand turntable cover.

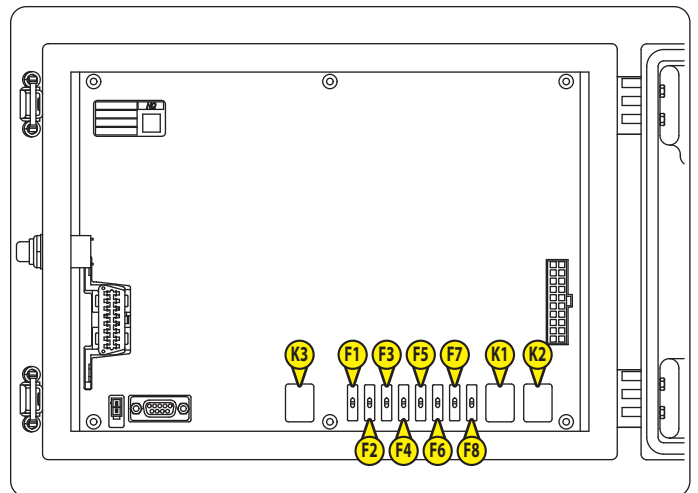

⚠ IMPORTANT ⚠

Wait until the diesel engine cools if it has been running for a while.

No flames or sparks. Do not smoke during this maintenance.

Always bleed the fuel supply circuit when:

- *The fuel tank has been drained and then filled.*
- *There has been a fuel breakdown and then the fuel tank has been filled.*
- *A component of the fuel supply circuit has been cleaned or replaced.*

If the diesel engine runs irregularly or stops after bleeding the fuel supply circuit, check the condition of the entire fuel supply circuit.

- Switch off the machine.
- Open the left-hand turntable cover.
- Locate the water separator **1**.
- Turn the faucet **2** to the ON position "ON".
- Switch on the machine.
- Wait 15 seconds, even if the preheat cycle has finished, and start the diesel engine.
- Allow it to idle for 5 minutes.
- Check for fuel leaks.
- Switch off the machine.

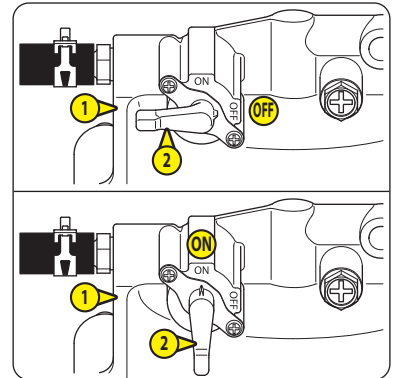
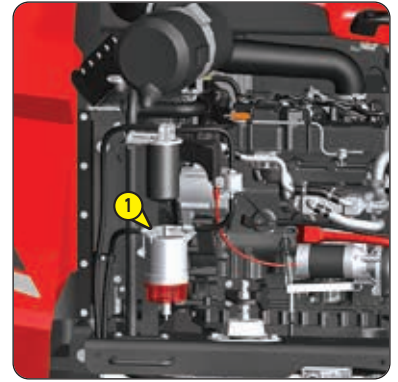

USE

Swiveling engine support

⚠ IMPORTANT ⚠

Always use the handle **A** to open and close the swiveling engine support.

Make sure that the safety strut **B** is properly locked in position **III** before carrying out any maintenance on the machine.

OPEN THE SWIVELING ENGINE SUPPORT

- Open the left-hand turntable cover.
- Remove the screw, nut and washer **I**.
- Pull on the handle **A** to open the swiveling engine support.
- Locate the safety strut **B**. Make sure that it is properly locked in position **III**, refer to steps **I**, **II** and **III** in the illustration.

CLOSE THE SWIVELING ENGINE SUPPORT

- Unlock the safety strut **B**, reversing the procedure for locking it.
- Push on the handle **A** to refit the swiveling engine support.
- Refit the screw, nut and washer **I**.
- Close the left-hand turntable cover.

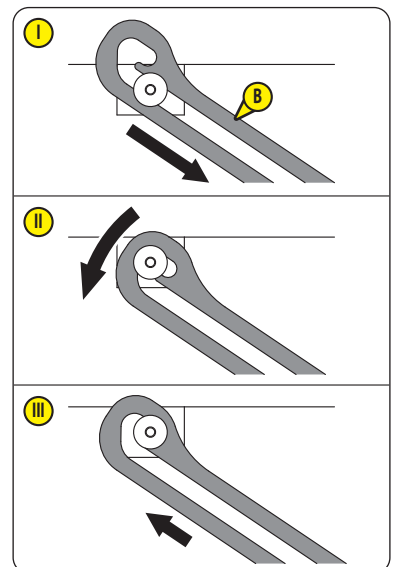
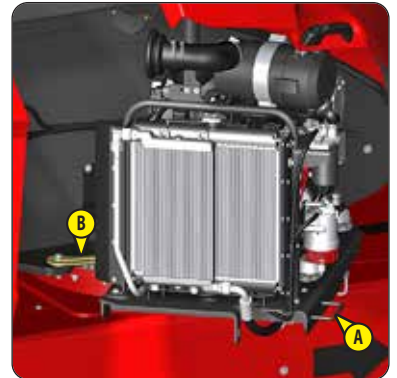
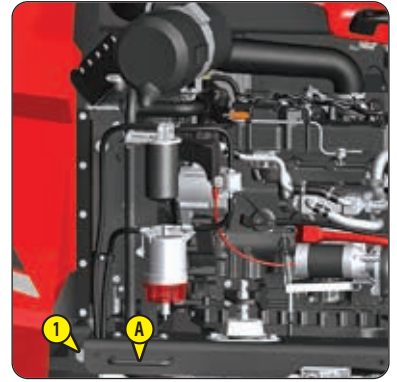

4 - ATTACHMENTS

4 - ATTACHMENTS

PIPE SUPPORT	2-3
INTRODUCTION	2-3
STICKERS	2-3
SPECIFICATIONS	2-4
INSTALLATION	2-5
DISMANTLING	2-6
INSTRUCTIONS FOR USE	2-7
ADJUSTMENT	2-8
PANEL SUPPORT	2-9
INTRODUCTION	2-9
STICKERS	2-9
SPECIFICATIONS	2-10
INSTALLATION	2-11
DISMANTLING	2-13
INSTRUCTIONS FOR USE	2-14

PIPE SUPPORT

INTRODUCTION

⚠ IMPORTANT ⚠

- The pipe support can be installed on:
- The standard platform without gate.
 - The standard platform with gate (option).

Installation of the pipe support is strictly forbidden on the narrow platform without a gate (option).

The pipe support and the panel support must not be installed at the same time on the same platform:

- Remove the panel support if the pipe support is installed.

The pipe support must be installed and removed by qualified maintenance personnel.

STICKERS

⚠ IMPORTANT ⚠

- Clean all the stickers so that they are legible.
Any stickers which are illegible or damaged must be replaced.
Check that the stickers are present after replacing any spare parts.

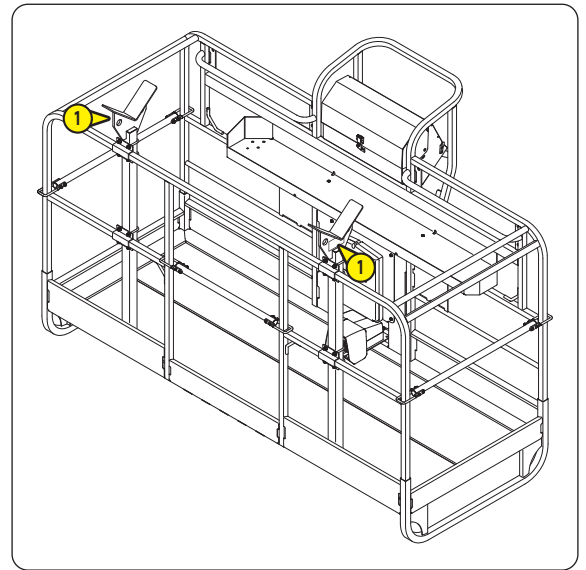

1 - PIPE SUPPORT STICKER

Part No. 52557917

Indicates the maximum permissible weight on the pipe support.

Note: 1 sticker on each support, total quantity = 2.

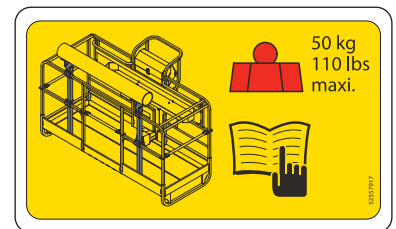

SPECIFICATIONS



The weight of the pipe support reduces the platform's maximum load capacity.

LOAD SPECIFICATIONS		260 TJ+			±
Machine					
- Maximum load capacity of the platform: there is nobody in the platform, the pipe support is installed without any load on it	kg (lbs)	393 (866)			-
- Maximum number of people in the platform (indoor use/outdoor use)		1 / 1	2 / 2	3 / 3	-
- Maximum load capacity of the pipe support	kg (lbs)	50 (110)	50 (110)	50 (110)	-
- Maximum remaining load capacity of the platform depending on the number of people in the platform: the pipe support is installed with the maximum load on it	kg (lbs)	263 (579)	183 (403)	103 (227)	-

LOAD SPECIFICATIONS		280 TJ					±
		ZONE A *			ZONE B *		
Machine							
- Maximum load capacity of the platform: there is nobody in the platform, the pipe support is installed without any load on it	kg (lbs)	335 (738)			225 (496)		-
- Maximum number of people in the platform (indoor use/outdoor use)		1 / 1	2 / 2	3 / 3	1 / 1	2 / 2	-
- Maximum load capacity of the pipe support	kg (lbs)	50 (110)	50 (110)	50 (110)	50 (110)	50 (110)	-
- Maximum remaining load capacity of the platform depending on the number of people in the platform: the pipe support is installed with the maximum load on it	kg (lbs)	205 (451)	125 (275)	45 (99)	95 (209)	15 (33)	-

* 2 - INSTRUCTIONS: DIMENSIONS AND AMPLITUDE OF MOVEMENT 280 TJ.

⚠ IMPORTANT ⚠

Check the condition of all the components and stickers whenever the pipe support is being installed. Replace them if necessary.

Replace the nuts ⑤ whenever the pipe support is being installed.

The supports ① must be installed inside the platform and must rest on the platform floor.

The supports ① must be installed symmetrically on each side of the platform and must be perpendicular to the platform floor.

- Start the diesel engine.
- Place the machine on a level surface.
- Put the machine in transport position. Put the turntable and the platform in neutral position, 2 - DESCRIPTION: OPERATING THE MACHINE: TRANSPORT/WORKING POSITION.
- Fully lower the jib arm.
- Switch off the machine.
- Put the first support ① inside the platform between the 2 vertical guardrails A1 and B1.

Note: place the sticker C on the outside.

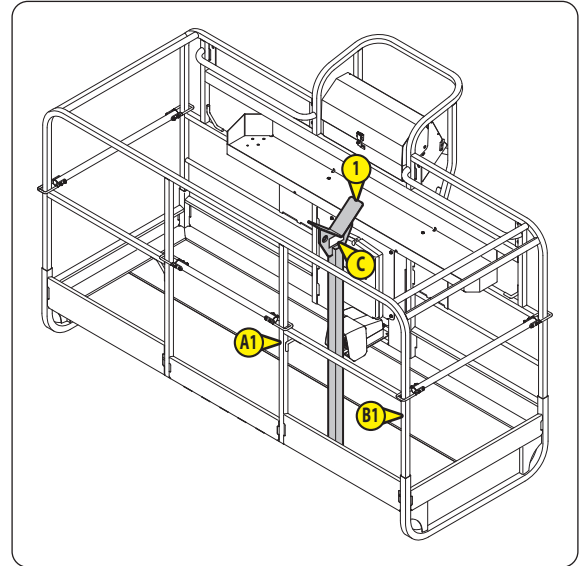

- Screw the first support ① to the platform using 2 clamps ② and fasteners ③, ④ and ⑤.

Note: hand-tighten the nuts ⑤.

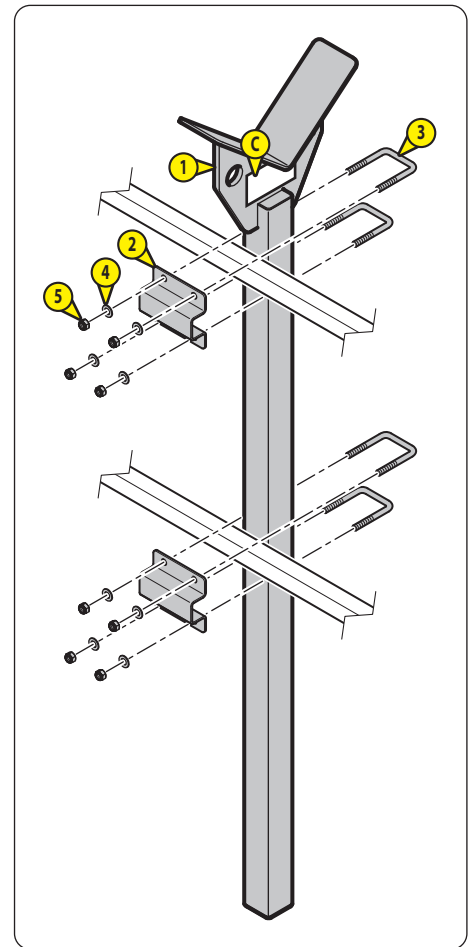

- Put the second support **1** inside the platform between the 2 vertical guardrails **A2** and **B2**.

Note: place the sticker **C** on the outside.

- Screw the second support **1** to the platform using 2 clamps **2** and fasteners **3**, **4** and **5**, refer to the previous page.

Note: hand-tighten the nuts **5**.

- Adjust the distance between the two supports **1**.
- Tighten all the nuts **5** crosswise:
 - The nuts are correctly tightened when 2 threads of the U-bolts **3** are visible.

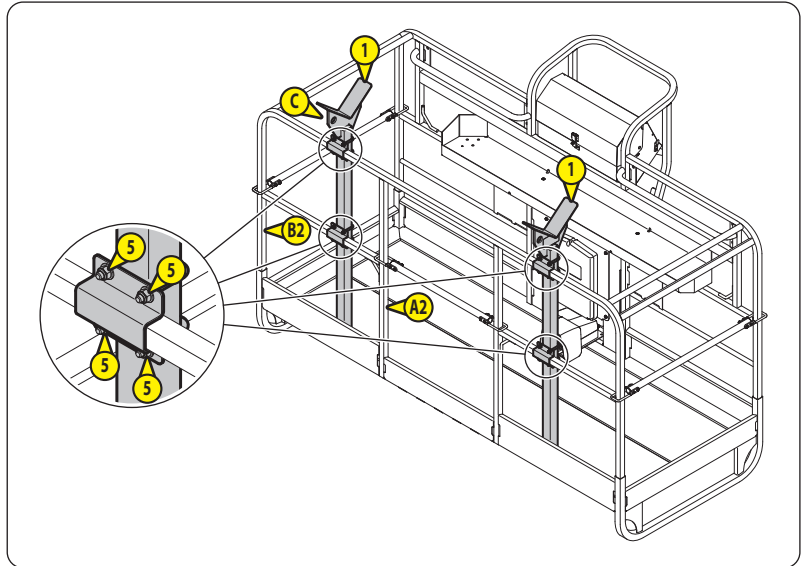

DISMANTLING

⚠ IMPORTANT ⚠

Whenever the pipe support is dismantled:

- The nuts **5** must be replaced whenever the pipe support is installed. It is recommended that they are replaced with new ones for the next installation.
- Check the condition of all the other components and stickers. Replace them if necessary.
- Store the pipe support in a clean, dry place.

- Start the diesel engine.
- Place the machine on a level surface.
- Put the machine in transport position. Put the turntable and the platform in neutral position, $\sphericalangle 2$ - DESCRIPTION: OPERATING THE MACHINE: TRANSPORT/WORKING POSITION.
- Fully lower the jib arm.
- Switch off the machine.
- Unscrew the fasteners **3**, **4** and **5**, refer to the previous page.
- Remove the 2 supports **1** and the 4 clamps **2**.
- Discard the nuts **5**.
- Store the pipe support with new nuts **5**.

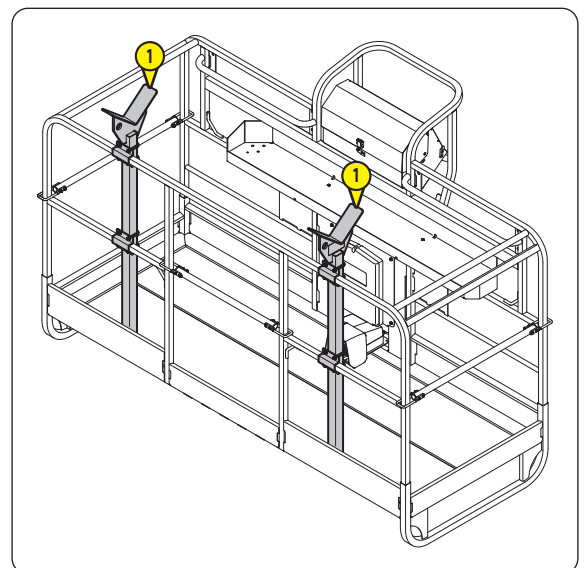

⚠ IMPORTANT ⚠

- The weight of the pipe support reduces the platform's maximum load capacity, \triangleleft SPECIFICATIONS.*
- Check that the pipe support is correctly adjusted, \triangleleft ADJUSTMENT.*
- The machine must be on a level surface and the platform must be level before placing pipes on the pipe support.*
- The length of the pipes must not exceed the width of the platform.*
- The pipes must be centered with the platform.*
- Make sure that the straps are solid enough to take the weight of the pipes.*
- Make sure that the pipes are properly secured with straps before lifting the platform.*

- Place the machine on a level surface.
- Put the machine in transport position. Put the turntable and the platform in neutral position, \triangleleft 2 - DESCRIPTION: OPERATING THE MACHINE: TRANSPORT/WORKING POSITION.
- Fully lower the jib arm.
- Ensure that the platform is level. If necessary, tilt the platform/ jib arm up or down.
- If necessary, adjust the distance between the supports, \triangleleft ADJUSTMENT.
- Place 1 or more pipes on the pipe support.
- Attach the pipes to the supports using a strap on each side.

Note: the straps are not supplied with the pipe support.

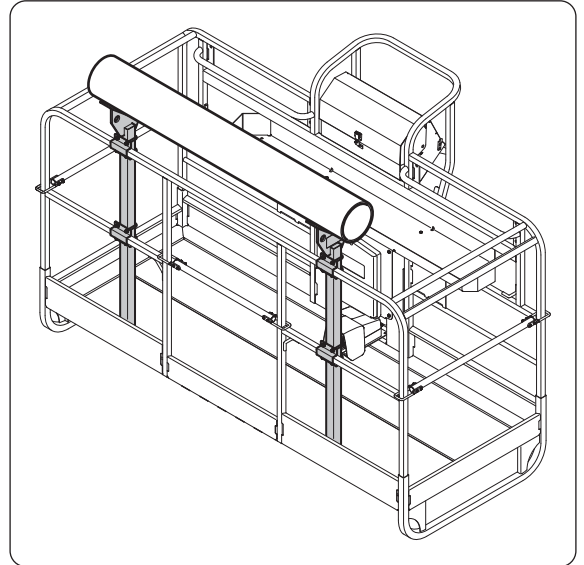

⚠ IMPORTANT ⚠

*The supports ① must be installed inside the platform and must rest on the platform floor.
The supports ① must be installed symmetrically on each side of the platform and must be perpendicular to the platform floor.*

- Place the machine on a level surface.
- Put the machine in transport position. Put the turntable and the platform in neutral position, 2 - DESCRIPTION: OPERATING THE MACHINE: TRANSPORT/WORKING POSITION.
- Fully lower the jib arm.
- Switch off the machine.
- Loosen the nuts ⑤ slightly.
- Adjust the width between the 2 supports ①.
- Tighten all the nuts ⑤ crosswise:
 - The nuts are correctly tightened when 2 threads of the U-bolts ③ are visible.

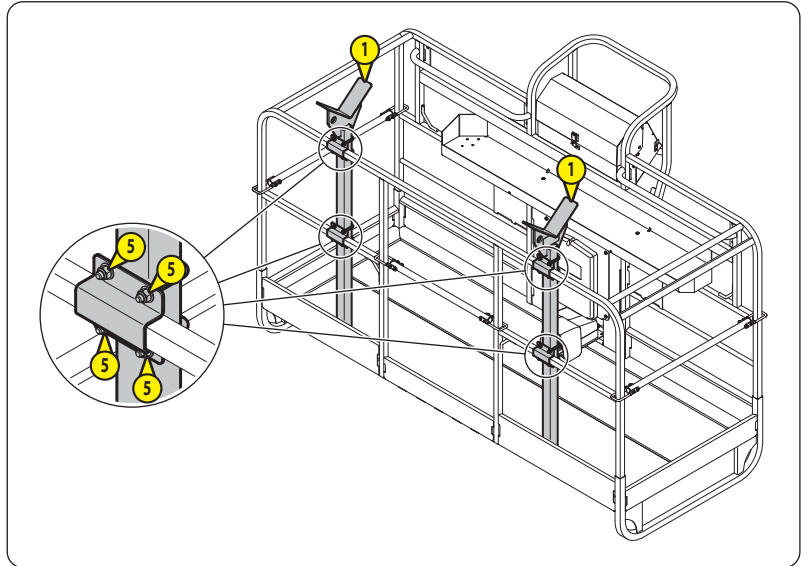

PANEL SUPPORT

INTRODUCTION

⚠ IMPORTANT ⚠

- The panel support can be installed on:
- The standard platform without gate.
 - The standard platform with gate (option).

Installation of the panel support is strictly forbidden on the narrow platform without a gate (option).

The pipe support and the panel support must not be installed at the same time on the same platform:

- The pipe support must be removed if the panel support is installed.

The panel support must be installed or dismantled by qualified maintenance personnel.

STICKERS

⚠ IMPORTANT ⚠

- Clean all the stickers so that they are legible.
- Any stickers which are illegible or damaged must be replaced.
- Check that the stickers are present after replacing any spare parts.

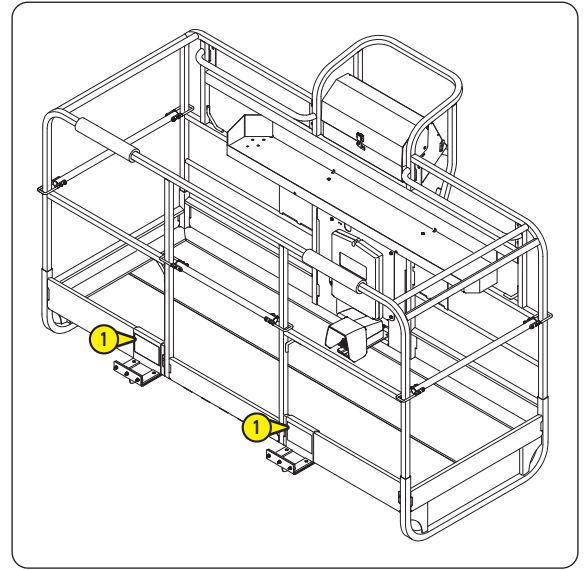

1 - PANEL SUPPORT STICKER

Part No. 52557913

Indicates the maximum permissible weight on the panel support and the maximum dimensions of the panel(s).

Note: 1 sticker on each support, total quantity = 2.

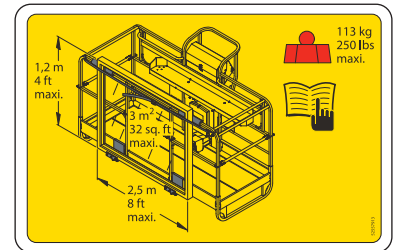

SPECIFICATIONS



The weight of the panel support reduces the platform's maximum load capacity.

LOAD SPECIFICATIONS		260 TJ+			±
Machine					
- Maximum load capacity of the platform: there is nobody in the platform, the panel support is installed without any load on it	kg (lbs)	398 (877)			-
- Maximum number of people in the platform (indoor use/ outdoor use)		1 / 1	2 / 2	3 / 3	-
- Maximum load capacity of the panel support	kg (lbs)	113 (250)	113 (250)	113 (250)	-
- Maximum remaining load capacity of the platform depending on the number of people in the platform: the panel support is installed with the maximum load on it	kg (lbs)	205 (451)	125 (275)	45 (99)	-

LOAD SPECIFICATIONS		280 TJ					±
		ZONE A *			ZONE B *		
Machine							
- Maximum load capacity of the platform: there is nobody in the platform, the panel support is installed without any load on it	kg (lbs)	340 (749)			230 (507)		-
- Maximum number of people in the platform (indoor use/outdoor use)		1 / 1	2 / 2	3 / 3	1 / 1	2 / 2	-
- Maximum load capacity of the panel support	kg (lbs)	113 (250)	113 (250)	100 (220)	113 (250)	70 (154)	-
- Maximum remaining load capacity of the platform depending on the number of people in the platform: the panel support is installed with the maximum load on it	kg (lbs)	147 (324)	67 (147)	0 (0)	37 (81)	0 (0)	-

* 2 - INSTRUCTIONS: DIMENSIONS AND AMPLITUDE OF MOVEMENT 280 TJ.

⚠ IMPORTANT ⚠

Check the condition of all the components and stickers whenever the panel support is being installed. Replace them if necessary.

Replace the nuts ⑥ and ⑬ whenever the panel support is being installed.

The configurations ① and ② are the only ones authorized.

Always use the original strap supplied with the panel support.

- Start the diesel engine.
- Place the machine on a level surface.
- Put the machine in transport position. Put the turntable and the platform in neutral position, ④ 2 - DESCRIPTION: OPERATING THE MACHINE: TRANSPORT/WORKING POSITION.
- Raise the jib arm until the floor of the platform is about 1.2 m (4 ft.) off the ground.
- Switch off the machine.
- Position the 2 supports ① on the base boards on either side of the platform.

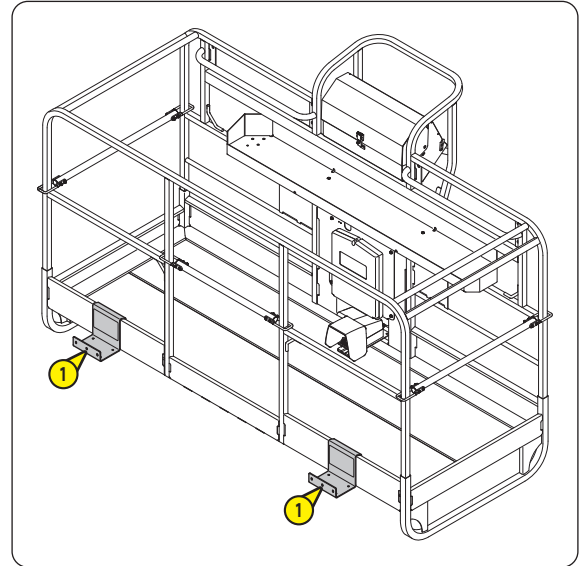

- Screw the 2 supports ① onto the platform using the clamps ②, the pads ③ and the fasteners ④, ⑤ and ⑥:
 - The nuts are correctly tightened when the screw heads ④ are embedded by about 2.5 mm into the pads (2 screw threads ④ must be visible).

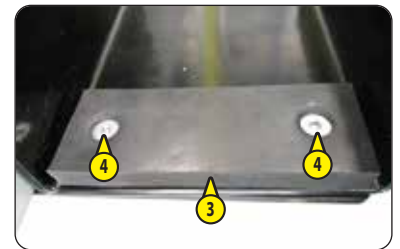
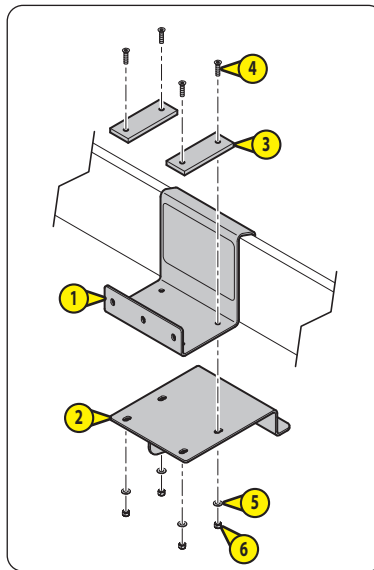

- If the pads ⑦ are not in place, screw them in using the fasteners ⑧, ⑨ and ⑩:
 - Tightening torque = 8.2 N.m ± 1.6 N.m

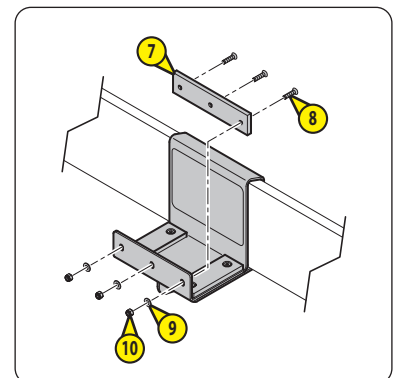

- Choose one of the 2 configurations:

CONFIGURATION	I	II
Minimum panel width	m (ft) 1.2 (4)	2.2 (6.5)
Maximum panel width	m (ft) 2.5 (8)	
Maximum panel height	m (ft) 1.2 (4)	

- Unscrew the fastening elements **A** or **B** (screws **11**, washers **12** and nuts **13**) depending on the configuration chosen.
- Discard the nuts **13**.
- Move and screw the 2 supports using the fastening elements **A** or **B**, replace the nuts **13** with new ones:
 - Tightening torque = 20 N.m ± 4 N.m

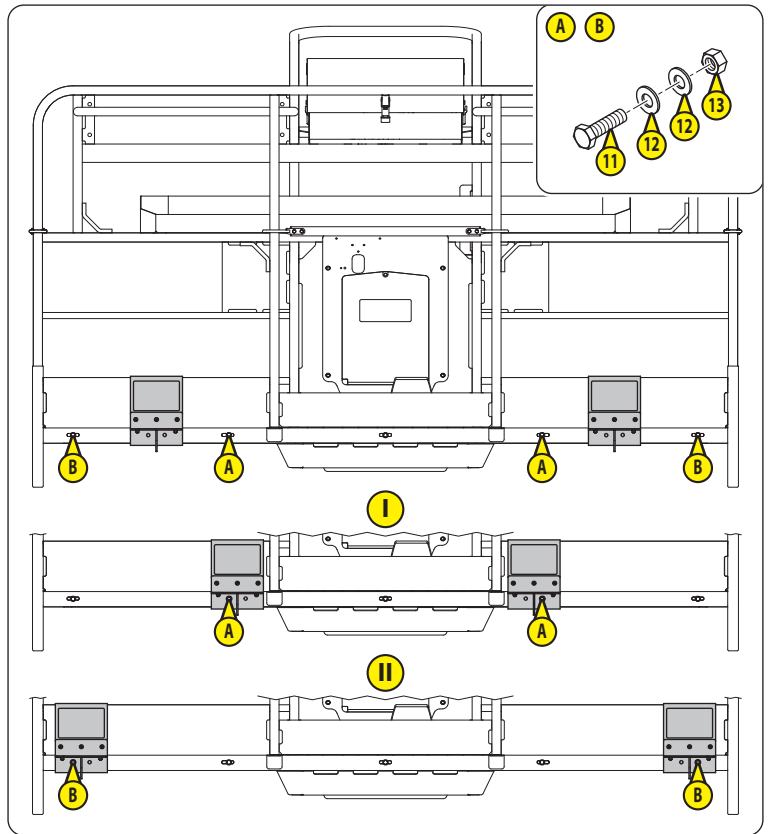

STANDARD PLATFORM WITHOUT GATE

- Start the diesel engine.
- Fully lower the jib arm.
- Switch off the machine.
- Install the foam profiles **14** and the sleeves **15**.
- Attach the strap **16** provided between the 2 guardrails **C** and **D** and between the 2 guardrails **E** and **F**.

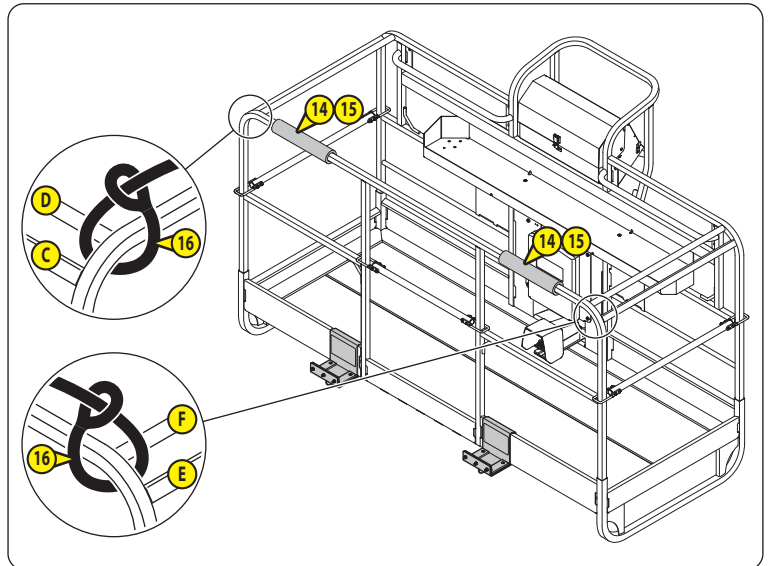

STANDARD PLATFORM WITH GATE (OPTION)

- Start the diesel engine.
- Fully lower the jib arm.
- Switch off the machine.
- Install the foam profiles **14** and the sleeves **15**.
- Attach the strap **16** provided between the 2 guardrails **C** and **D** and around the guardrail **G**.

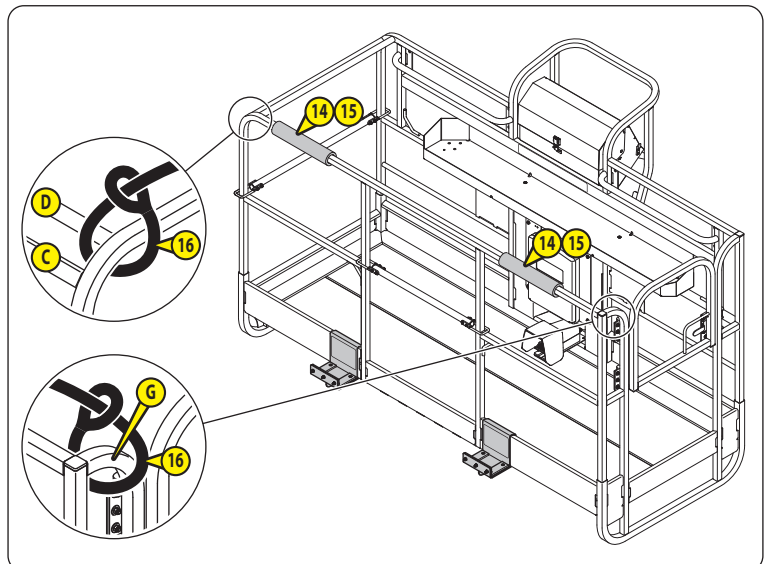

⚠ IMPORTANT ⚠

Replace the nuts **13** each time the panel support is removed.

Each time is panel support is dismantled:

- The nuts **6** and **13** must be replaced whenever the panel support is installed. It is recommended that they are replaced with new ones for the next installation.
- Check the condition of all the other components and stickers. Replace them if necessary.
- Store the panel support in a clean, dry place.

- Start the diesel engine.
- Place the machine on a level surface.
- Put the machine in transport position. Put the turntable and the platform in neutral position, 2 - DESCRIPTION: OPERATING THE MACHINE: TRANSPORT/ WORKING POSITION.
- Raise the jib arm until the floor of the platform is about 1.2 m (4 ft.) off the ground.
- Switch off the machine.
- Unscrew the fastening elements **A** or **B** (screws **11**, washers **12** and nuts **13**) depending on the configuration **I** or **II**.
- Unscrew the fastening screws **4**, **5** and **6**, INSTALLATION.
- Remove the 2 supports **1**, the 2 clamps **2** and the 4 pads **3**, INSTALLATION.
- Discard the nuts **6** and **13**.

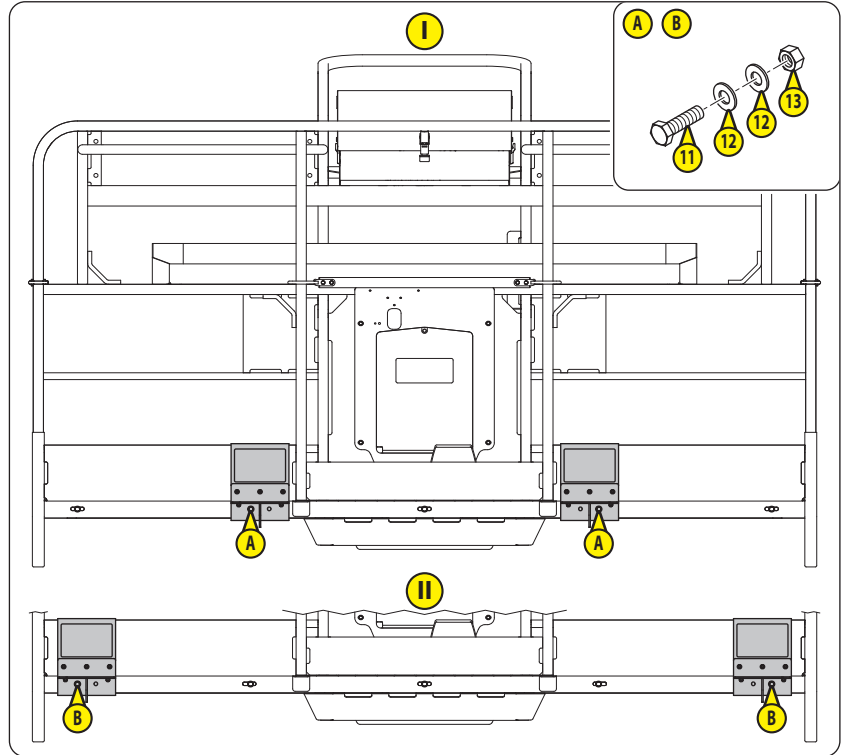

- Put the fasteners **A** or **B** (screws **11**, washers **12** and nuts **13**) back in place, replace the nuts **13** with new ones:
 - Tightening torque = 20 N.m ± 4 N.m
- Store the panel support with new nuts **6** and **13**.

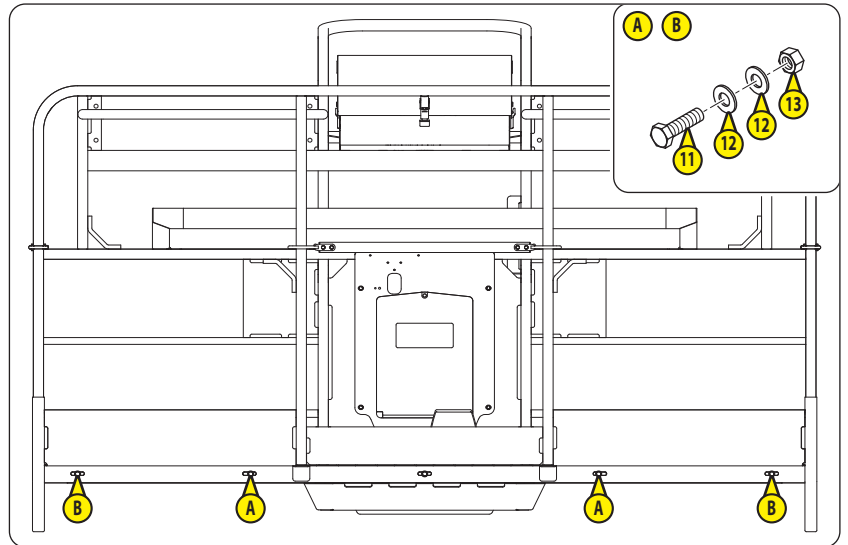

⚠ IMPORTANT ⚠

*The weight of the panel support reduces the platform's maximum load capacity, \triangleleft SPECIFICATIONS.
 The configurations **I** and **II** are the only ones authorized, \triangleleft INSTALLATION to change the configuration.
 The machine must be on a level surface and the platform must be level before placing panels on the panel support.
 The panels must be centered with the platform.
 Make sure that the panels are properly secured with the strap before lifting the platform.*

CONFIGURATION		I	II
Minimum panel width	m (ft)	1.2 (4)	2.2 (6.5)
Maximum panel width	m (ft)	2.5 (8)	
Maximum panel height	m (ft)	1.2 (4)	

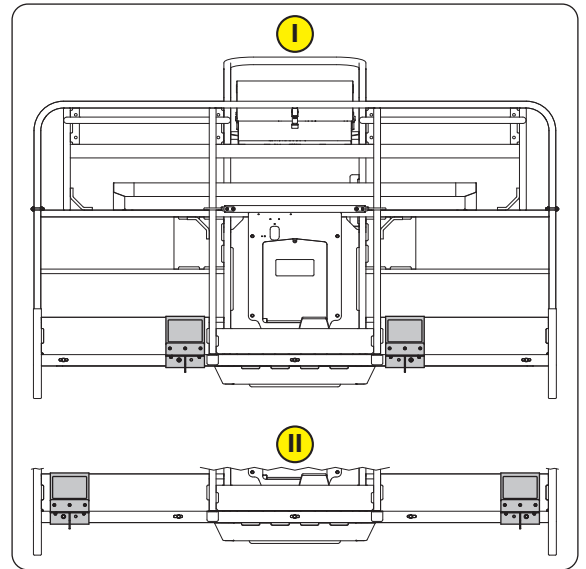

- Place the machine on a level surface.
- Put the machine in transport position. Put the turntable and the platform in neutral position, \triangleleft 2 - DESCRIPTION: OPERATING THE MACHINE: TRANSPORT/WORKING POSITION.
- Raise or lower the jib arm to bring the panel support to a comfortable height.
- Ensure that the platform is level. If necessary, tilt the platform/ jib arm up or down.
- Place one or more panels on the panel support.
- Attach the panels to the platform using the strap.

Note: the strap is supplied with the panel support.

