



**647670 EN (20/03/2025)**

MLT 630 105D V ST4 S2  
MLT 630 105D V CP ST4 S2  
MLT 730 115D V ST4 S1  
MLT 730 115D V CP ST4 S1

**OPERATOR'S MANUAL**  
**(ORIGINAL INSTRUCTIONS)**

## **IMPORTANT**

*Carefully read and understand this instruction manual before using this machine.*

*It contains all information relating to operation, handling and equipment, as well as important recommendations to be followed.*

*This document also contains precautions for use, as well as information on the service and routine maintenance required to ensure the machine's continued reliability and safety of use.*

**WHENEVER YOU SEE THIS SYMBOL, IT MEANS:**



**PLEASE NOTE! BE CAREFUL! YOUR SAFETY, THAT OF OTHERS, OR THE SAFETY OF THE MACHINE IS AT RISK.**

- This manual has been produced based on the equipment list and technical characteristics given at the time of its design.
- The machine's equipment level depends on the options chosen and the country of sale.
- Depending on the machine's options and the date of sale, certain equipment or functions described in this manual may not be present on this machine.
- Descriptions and figures are non-binding.
- MANITOU reserves the right to change its models and their equipment without being required to update this manual.
- The MANITOU network, consisting exclusively of qualified professionals, is available to answer all your questions.
- This manual is an integral part of the machine.
- It is to be kept in its storage location at all times for ease of reference.
- Give this manual to the new owner if the machine is resold.

1st ISSUE	13/12/2017	
UPDATED	20/04/2018	+ MLT 730 115D V ST4 S1 + MLT 730 115D V CP ST4 S1 1-10 – 1-34 2-8 ; 2-9 ; 2-24 – 2-30 ; 2-34 ; 2-35 ; 2-40 – 2-51 ; 2-53 ; 2-71 ; 2-75 ; 2-85 – 2-87 ; 2-90 ; 2-97 – 2-99 3-10 ; 3-11 4-11
	29/04/2019	2-10 ; 2-11 ; 2-32 – 2-35 ; 2-72 ; 2-76 – 2-100 3-4 ; 3-6 ; 3-9 – 3-12 ; 3-15 ; 3-20 – 3-23
	19/07/2019	3-20
	24/10/2024	3-7 ; 3-31
	20/03/2025	0-0 1-1 – 1-34 2-91 3-9 ; 3-12 – 3-13 ; 3-22

*The brochure and all its contents, including diagrams, are the proprietary and confidential intellectual property of Manitou BF and / or its subsidiaries ("Manitou Group"). Any reproduction, publication or dissemination of any part of the brochure without the express written authorization of Manitou Group is strictly prohibited. Any violation of this provision will subject the offending party to prosecution by Manitou Group to the fullest extent of the law. The logos and the company's visual identity are the property of Manitou Group and may not be used without the express written authorization of Manitou Group.*

*All trademarks, registered and unregistered, is and shall remain the property of Manitou BF or its respective owner.*

*Any reproduction, source code access, decompilation, modification, copy (other than backup copies), correction of errors, transmission or distribution of any software built into Manitou Group machines is strictly prohibited.*

*In the event that the measures above nevertheless prove essential to enable use of the software, in accordance with its destination, or to obtain the information required for interoperability with other software created independently, the user should contact Manitou Group in advance and Manitou may, at its sole discretion, take the necessary measures or give access to only the information strictly necessary for interoperability.*

*Any breach of these requirements is likely to constitute a counterfeiting offense subject to legal action by Manitou Group.*

*Connected Manitou Group machines are equipped with boxes that collect technical data on the machines (such as geo-tracking data or data on component operation). This data, which is organized, processed and enhanced by algorithms and expertise proprietary to Manitou Group, constitutes, in combination with other elements, independent or not, a protected database according to laws & regulations on IP purposes.*

*It is strictly forbidden to have access to all or part of this database and to use the data (including in the event of accidental access) without explicit prior authorization from Manitou Group. In the event that Manitou Group authorizes a Manitou Group machine user to access all or part of this database, Manitou Group, as producer of this database, cedes to the user only a right to personal, non-exclusive, non transferable use of the database, and only by access to an information technology platform hosted by a server owned or controlled by Manitou Group.*

*In any case, the following are strictly prohibited:*

- any extraction, reproduction, representation, reuse through provision to the public, distribution, transfer, permanent or temporary, on any medium, by any means, and in any form whatsoever, of all or of a qualitatively or quantitatively substantial part of the contents of this database,*
- any extraction, reproduction, representation, reuse through provision to the public, distribution, transfer, repeated or systematic of qualitatively or quantitatively insubstantial parts of the content of the database during operations manifestly exceeding normal use of the database by the user of the machine for his own needs,*
- any use of means to bypass technical protection measures for databases or software source code embedded in the boxes, in keeping according to laws & regulations on IP purposes.*

*The latest updated version in force and binding of this document is the version available on demand.*

*Only the electronic version is maintained.*

*MANITOU BF S.A. Public limited company with a board of directors.*

*Head office: 430 rue de l'Aubinière - 44150 Ancenis - France*

*Share capital: €39,548,949*

*Entered in the Nantes Trade and Companies Register under number 857 802 508.*

*Tel.: +33 (0) 2 40 09 10 11*

*www.manitou.com*

**1 - OPERATING AND SAFETY INSTRUCTIONS**

**2 - DESCRIPTION**

**3 - MAINTENANCE**

**4 - OPTIONAL ADAPTABLE ATTACHMENTS FOR THE RANGE**





# ***1 - OPERATING AND SAFETY INSTRUCTIONS***

# 1 - OPERATING AND SAFETY INSTRUCTIONS

<b>INSTRUCTIONS TO THE COMPANY MANAGER</b>	<b>1-4</b>
<b>THE SITE</b>	<b>1-4</b>
<b>THE OPERATOR</b>	<b>1-4</b>
<b>THE MACHINE</b>	<b>1-4</b>
A - SUITABILITY OF THE MACHINE FOR THE TASK . . . . .	1-4
B - ADAPTING THE MACHINE TO USUAL ENVIRONMENTAL CONDITIONS . . . . .	1-4
C - MODIFYING THE MACHINE. . . . .	1-5
D - FRENCH ROAD TRAFFIC RULES. . . . .	1-5
E - MACHINE CAB PROTECTION. . . . .	1-5
<b>INSTRUCTIONS</b>	<b>1-6</b>
<b>MAINTENANCE</b>	<b>1-6</b>
<b>INSTRUCTIONS FOR THE OPERATOR</b>	<b>1-8</b>
<b>FOREWORD</b>	<b>1-8</b>
<b>GENERAL INSTRUCTIONS</b>	<b>1-8</b>
A - OPERATOR'S MANUAL. . . . .	1-8
B - AUTHORIZATION FOR USE IN FRANCE. . . . .	1-8
C - MAINTENANCE . . . . .	1-8
D - TIRES . . . . .	1-9
E - MODIFYING THE MACHINE. . . . .	1-9
F - LIFTING PEOPLE. . . . .	1-9
<b>OPERATING INSTRUCTIONS UNLADEN AND LADEN</b>	<b>1-10</b>
A - BEFORE STARTING UP THE MACHINE . . . . .	1-10
B - AVAILABLE IN THE DRIVER'S CAB. . . . .	1-10
C - ENVIRONMENT . . . . .	1-10
D - VISIBILITY . . . . .	1-11
E - STARTING THE MACHINE . . . . .	1-12
F - OPERATING THE MACHINE . . . . .	1-12
G - STOPPING THE MACHINE. . . . .	1-14
H - DRIVING THE MACHINE ON THE PUBLIC HIGHWAY. . . . .	1-15
<b>INSTRUCTIONS FOR HANDLING A LOAD</b>	<b>1-18</b>
A - CHOICE OF ATTACHMENTS . . . . .	1-18
B - WEIGHT OF LOAD AND CENTER OF GRAVITY . . . . .	1-18
C - LONGITUDINAL STABILITY LIMITER AND WARNING DEVICE. . . . .	1-18
D - TRANSVERSE ATTITUDE OF THE MACHINE. . . . .	1-19
E - PICKING UP A LOAD ON THE GROUND . . . . .	1-19
F - PICKING UP AND PUTTING DOWN A HIGH LOAD ON TIRES . . . . .	1-20
G - PICKING UP AND PUTTING DOWN A HIGH LOAD ON STABILIZERS. . . . .	1-22
H - PICKING UP AND PUTTING DOWN A SUSPENDED LOAD. . . . .	1-24
I - TRAVELING WITH A SUSPENDED LOAD. . . . .	1-24
<b>INSTRUCTIONS FOR USE AS A LOADER</b>	<b>1-25</b>
A - LOADING . . . . .	1-25
B - BACKFILLING. . . . .	1-25
<b>INSTRUCTIONS FOR USING THE MOBILE ELEVATING WORK PLATFORM</b>	<b>1-26</b>
A - AUTHORIZATION FOR USE . . . . .	1-26
B - SUITABILITY OF THE PLATFORM FOR THE JOB . . . . .	1-26
C - PROVIDED ON THE PLATFORM . . . . .	1-26
D - USING THE PLATFORM. . . . .	1-27
E - ENVIRONMENT . . . . .	1-28
F - MAINTENANCE . . . . .	1-28
<b>INSTRUCTIONS FOR USING THE RADIO-CONTROL</b>	<b>1-29</b>
HOW TO USE THE RADIO-CONTROL. . . . .	1-29
PROTECTIVE DEVICES. . . . .	1-29

**MACHINE MAINTENANCE INSTRUCTIONS** **1-30**

---

<b>GENERAL INSTRUCTIONS</b>	<b>1-30</b>
<b>PLACING THE JIB SAFETY WEDGE</b>	<b>1-30</b>
FITTING THE WEDGE . . . . .	1-30
REMOVING THE WEDGE . . . . .	1-30
FITTING THE WEDGE . . . . .	1-30
REMOVING THE WEDGE . . . . .	1-30
<b>MAINTENANCE</b>	<b>1-31</b>
MAINTENANCE LOGBOOK . . . . .	1-31
<b>LUBRICANT AND FUEL LEVELS</b>	<b>1-31</b>
<b>HYDRAULICS</b>	<b>1-31</b>
<b>ELECTRICITY</b>	<b>1-31</b>
<b>WELDING ON THE MACHINE</b>	<b>1-31</b>
<b>WASHING THE MACHINE</b>	<b>1-32</b>
<b>TRANSPORTING THE MACHINE</b>	<b>1-32</b>

**PROLONGED MACHINE SHUTDOWN** **1-32**

---

<b>INTRODUCTION</b>	<b>1-32</b>
<b>PREPARATION OF THE MACHINE</b>	<b>1-32</b>
<b>DEF (Diesel Exhaust Fluid) TANK</b>	<b>1-32</b>
<b>PROTECTING THE ENGINE</b>	<b>1-33</b>
<b>MACHINE PROTECTION</b>	<b>1-33</b>
<b>RETURNING THE MACHINE TO SERVICE</b>	<b>1-33</b>

**DISPOSING OF THE MACHINE** **1-34**

---

<b>RECYCLING OF MATERIALS</b>	<b>1-34</b>
METALS . . . . .	1-34
PLASTICS . . . . .	1-34
RUBBER . . . . .	1-34
GLASS . . . . .	1-34
<b>ENVIRONMENTAL PROTECTION</b>	<b>1-34</b>
WORN OR DAMAGED PARTS . . . . .	1-34
USED OIL . . . . .	1-34
USED BATTERIES . . . . .	1-34

# INSTRUCTIONS TO THE COMPANY MANAGER

## THE SITE

Proper management of the machine's area of travel will reduce the risk of accidents:

- ground not unnecessarily uneven or obstructed,
- no excessive slopes,
- pedestrian traffic controlled, etc.

## THE OPERATOR

- Only qualified, authorized personnel can use the machine. This authorization is given in writing by the appropriate person in the establishment where the machine is to be used and must be carried permanently by the operator.

### ⚠ IMPORTANT ⚠

*Experience has shown that there are a number of inappropriate ways in which the machine might be operated. Such foreseeable misuse, of which the main examples are listed below, are strictly forbidden.*

*- The foreseeable abnormal behavior resulting from ordinary negligence, but not from any intentional misuse of the equipment.*

*- The reflex reactions of a person in the event of a malfunction, incident, fault, etc. during operation of the machine.*

*- Behavior resulting from application of the "principle of least effort" when performing a task.*

*- For certain machines, the foreseeable behavior of such persons as: apprentices, teenagers, handicapped persons, trainees tempted to drive a machine, operators tempted to operate a machine to win a bet, in competition or for their own personal experience.*

*The person in charge of the equipment must take these criteria into account when assessing whether or not a person will make a suitable driver.*

## THE MACHINE

### A - SUITABILITY OF THE MACHINE FOR THE TASK

- MANITOU has ensured that this machine is suitable for use under the standard operating conditions defined in this operator's manual, with a **STATIC TEST COEFFICIENT OF 1.25** and a **DYNAMIC TEST COEFFICIENT OF 1**, as specified in harmonized standard **EN 1459** for variable reach machines.
- Before commissioning, the facility manager must make sure that the machine is appropriate for the work to be done, and perform certain tests (in accordance with applicable legislation).

### B - ADAPTING THE MACHINE TO USUAL ENVIRONMENTAL CONDITIONS

#### ⚠ IMPORTANT ⚠

*Lubricants are filled in the factory for average climatic use, i.e.: -15°C to 35°C.*

*For operation under more severe climatic conditions, before starting up, drain all circuits then fill using lubricants suitable for the ambient temperatures.*

*The same applies to the coolant.*

#### ⚠ IMPORTANT ⚠

*The machines are designed for outdoor use under normal atmospheric conditions and indoor use in suitably aerated and ventilated premises. It is prohibited to operate the machine in areas which presents a risk of fire or which are potentially explosive (e.g. refineries, fuel or gas depots, stores of flammable products, etc.).*

*Specialized equipment is available when operating in these areas (ask your dealer for information).*

- Our machines are designed to be used within a temperature range of -18 °C to +43 °C.
- In addition to the standard equipment fitted on your machine, many options are available, such as: road lighting, stop lights, rotating beacon light, reverse lights, front worklight, rear worklight, lifting structure worklight, etc. (depending on machine model).
- The operator must take into account the operating conditions to specify the machine's signaling and lighting equipment. Consult your dealer.
- Take into account the climatic and atmospheric conditions of the operation site. Consult your dealer for the suitability of lubricants and frost protection.
- Take into account the fire risk associated with use in dusty and flammable conditions (e.g. straw, flour, sawdust, organic waste, etc.).
- A machine operating in an area without fire extinguishing equipment must be equipped with an individual extinguisher. Solutions exist, consult your dealer.

Our machines comply with Directive 2014/30/EU (2015/208/EU for our type-approved "TRACTOR" machines) concerning electromagnetic compatibility (EMC), (UK : Electromagnetic Compatibility Regulations 2016) and with the corresponding harmonized standard EN 12895. Their correct operation is no longer guaranteed if they are used within areas in which the electromagnetic fields exceed the limit specified by this standard (20 V/m).

- Directive 2002/44/EC requires company managers to not expose their employees to excessive vibration doses. There is no recognized code of measurement for comparing the machines of different manufacturers. The actual doses received cannot therefore be measured under actual operating conditions at the user's premises.
- The following are some tips for minimizing these vibration doses:
  - Select the most suitable machine and attachment for the intended use.
  - Adapt the seat adjustment to the operator's weight (**depending on machine model**) and maintain it in good condition, as well as the cab suspensions. Inflate the tires in accordance with recommendations.
  - The seat is an essential way of reducing the vibrations transmitted to the operator. In the event of seat replacement, please contact MANITOU.
  - Ensure that the operators adapt their operating speed to suit the conditions on site.
  - As far as possible, arrange the site in such a way as to provide a flat running surface and remove obstacles and harmful potholes.

## C - MODIFYING THE MACHINE



**Modifying the structure and settings of the various components of your machine (hydraulic pressure, taring of limiters, engine speed, sensors, addition of extra equipment, addition of counterweights, unapproved and unauthorized attachments, alarm systems, etc.) yourself is strictly prohibited. In this case, the manufacturer cannot be held responsible.**

## D - FRENCH ROAD TRAFFIC RULES

(or see current legislation in other countries)

- Only one EC declaration of conformity is issued. It must be kept in a safe place.
- The road traffic rules for the machines are subject to the provisions of the highway code, according to the following categories:
  - Construction machinery (MT range): public works vehicle not predominantly for use on roads (point 6.9 of Article R.311-1 of the French Highway Code). The machine must have a 25 disc displayed on the rear of the machine and an operating license plate.
  - Non-type-approved "Tractor" machinery for agricultural work: (point 6.2 of Article R.311-1 of the French Highway Code). The machine must be fitted with an operating license plate.
  - Type-approved "Tractor" machinery for agricultural work: Agricultural tractor type T1a (point 5.1.1 of Article R.311-1 of the French Highway Code). The machine must be licensed.

## SPECIAL INSTRUCTIONS APPLICABLE TO TYPE-APPROVED "TRACTOR" MACHINES

- All approved machines are supplied with a "Tractor" certificate of compliance with Regulation 167/2013, to be retained by the owner, and a page of administrative details together with a CNIT number (national type approval code) for registration at the prefecture.
- The owner of the machine is responsible for carrying out the necessary procedures for obtaining the vehicle registration document within the time limit defined by the regulations.
- The operator must hold a category B driver's license, unless granted an exemption.
- The machine must be driven on the public highway in accordance with the instructions given in the manual supplied with the machine (Gross weight, Gross combination weight, towing load, axle loads, maximum speeds, etc. according to the type/version). The operator must be in possession of the machine's registration document.



**When towing a trailer or agricultural equipment, the traveling speed of the machine is limited to 25 km/h.**

**In this case, a "25" disc must be affixed to the rear of the convoy.**

## E - MACHINE CAB PROTECTION

- All machines comply with standard ISO 3471 Roll-over Protective Structures (ROPS)
- All machines comply with standard ISO 3449 Falling-Object Protective Structures (FOPS) (Level I or II) (↖ 2 - DESCRIPTION OF STICKERS AND PLATES)
- The windows used on our machines comply with standard ECE-R43 Operator Protective Structures (OPS).
- Approved "TRACTOR" machines also comply with the regulations:
  - (appendix 1322/2014-OCDE Code 4).
  - (appendix 1322/2014-OCDE Code 10).



**Structural damage or overturning, a modification, changes or a poorly executed repair can reduce the protective efficiency of the cab, canceling its compliance.**

**Do not perform welding or drilling on the cab structure.**

**Consult your dealer to determine the limits of this structure without canceling its compliance.**

## **INSTRUCTIONS**

---

- The operator's manual must always be in good condition, in the language of the operator and placed in the storage compartment provided.
- The operator's manual and any plates or stickers which are no longer legible or are damaged, must be replaced immediately.

## **MAINTENANCE**

---

**⚠ IMPORTANT ⚠**

*Refer to chapter: MACHINE MAINTENANCE INSTRUCTIONS.*

**⚠ IMPORTANT ⚠**

*Your machine must be periodically inspected to ensure its continued compliance.*

*The frequency of this inspection is defined by the legislation in force in the country in which the machine is used.*

- Maintenance or repairs other than those detailed in Part: 3 - MAINTENANCE must be carried out by qualified personnel (consult your dealer) and in the necessary safety conditions to preserve the health of the operator and any third party.
- Example for France "The manager in charge of the establishment using a machine must open and maintain a maintenance log for each machine (order of March 2, 2004) and undergo a general periodic inspection every 6 months (order of March 1, 2004)".



# INSTRUCTIONS FOR THE OPERATOR

## FOREWORD

### **⚠ IMPORTANT ⚠**

*The risk of accident while using, servicing or repairing this machine can be reduced if you follow the safety instructions and preventive measures detailed in this instruction manual.*

*Failure to respect the safety and operating instructions, or the instructions for repairing or servicing your machine may lead to serious, even fatal accidents.*

### **⚠ IMPORTANT ⚠**

*In order to reduce or prevent any danger with a MANITOU-approved attachment, follow the instructions in paragraph: 4 - ADAPTABLE ATTACHMENTS AVAILABLE ON THE RANGE: INTRODUCTION.*

- Only the operations and maneuvers described in these operator's manual must be performed. The manufacturer cannot predict all possible risky situations. Consequently, the safety instructions given in the operator's manual and on the machine itself are not exhaustive.
- At all times, as an operator, you must envisage, within reason, the possible risk to yourself, to others or to the machine when you use it.
- The operator is responsible for the machine in all circumstances, regardless of whether he is present in the driver's cab.

## GENERAL INSTRUCTIONS

### A – OPERATOR'S MANUAL

#### **⚠ IMPORTANT ⚠**

*Carefully read and understand this operator's manual before operating this machine.*

- The operator's manual must always be in good condition, in the language of the operator and placed in the storage compartment provided.
- Any operations or maneuvers not described in the operator's manual are proscribed.
- Follow the safety advice and the instructions described on the machine's stickers.
- Familiarize yourself with the machine on the ground where it will be operated.
- You must replace the instruction manual, as well as any plates or stickers, if they are no longer legible or are missing or damaged.

### B - AUTHORIZATION FOR USE IN FRANCE

*(or see current legislation in other countries).*

- Only qualified, authorized personnel can use the machine. This authorization is given in writing by the appropriate person in the establishment where the machine is to be used and must be carried permanently by the operator.
- The operator is not empowered to authorize the driving of the machine by another person.

### C - MAINTENANCE

- If the operator sees that the machine is not in good working order or does not comply with the safety instructions, he must inform his manager of this immediately.
- The operator is prohibited from carrying out any repairs or adjustments himself, unless he has been trained for this purpose. He must keep the machine properly cleaned if this is his responsibility.
- The operator must carry out the daily maintenance (↩ 3 - MAINTENANCE) before using the machine in his place of work.
- The operator is responsible for deciding and adjusting the frequency and type of the cleaning needed to prevent the risk of fire ensuing from the build-up of flammable material(s). The operator should pay special attention to all the areas of the machine where these high-risk materials are likely to accumulate (e.g. engine compartment, under the lifting structure, above the axles, inside the chassis, etc.).

## D - TIRES

### ⚠ IMPORTANT ⚠

*Do not use the machine if the wheels are damaged or excessively worn, because this could put your own safety or that of others at risk, or cause damage to the machine.*

- The operator must ensure tires are suitable for the nature of the ground (see contact surface with the ground for the tires in the chapter: 2 - DESCRIPTION: TIRES). Optional solutions are available, please consult your dealer.
  - SAND tires.
  - FARM tires.
  - Snow chains.
- The machine's four tires must be the same brand, the same dimensions, the same structure (radial or diagonal) and the same usage category (normal, snow or special), and must have the same degree of tread wear.
- In the event of tire replacement, use tires authorized by MANITOU that are the same type and dimensions. Using different tires voids the machine's type approval and you may be liable.
- If you are replacing just one of the machine's tires (e.g. because it is damaged), we recommend choosing a tire with the same degree of wear as the remaining tires so as not to damage the transmission's kinematic chain.

### ⚠ IMPORTANT ⚠

*Do not use the machine if the tires are damaged or excessively worn, because this could put your own safety or that of others at risk, or cause damage to the machine itself.*

*The fitting of foam inflated tires is prohibited and is not guaranteed by the manufacturer unless with prior authorization.*

## E - MODIFYING THE MACHINE

- ⚠ INSTRUCTIONS TO THE COMPANY MANAGER: ⚠ C - MODIFYING THE MACHINE.

## F - LIFTING PEOPLE

- The use of working equipment and load lifting attachments to lift people is:
  - either forbidden
  - or authorized exceptionally and under certain conditions (⚠ regulations in force in the country in which the machine is used).
- The pictogram posted at the operator station reminds you that:
  - Left-hand column
    - It is forbidden to lift people, with any kind of attachment, using a non PLATFORM-fitted machine.
  - Right-hand column
    - With a PLATFORM-fitted machine, people can only be lifted using platforms designed by MANITOU for this purpose.
- MANITOU sells equipment specifically designed for lifting people (OPTION PLATFORM-fitted machine; contact your dealer).

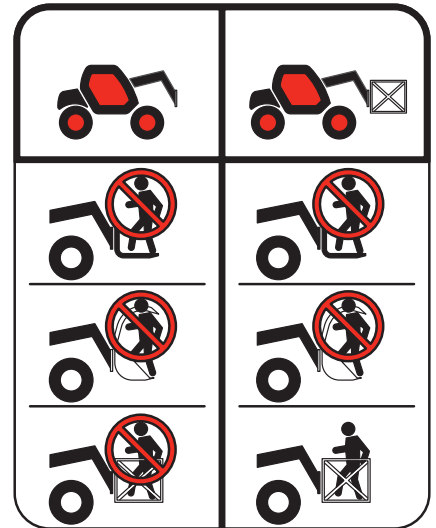

**A - BEFORE STARTING UP THE MACHINE**

- Perform the daily maintenance operations (< 3 - MAINTENANCE).
- Make sure that the driver's cab is clean, particularly the floor and floor mat. Check that no movable object may hinder the operation of the machine.
- Make sure the lights, turn signals and windshield wipers are working properly.
- Make sure the rear-view mirrors are in good condition, clean and properly adjusted.
- Make sure the horn works.

**B - AVAILABLE IN THE DRIVER'S CAB**

- Whatever his experience, the operator is advised to familiarize himself with the position and operation of all the controls and instruments before operating the machine.
- Wear clothes suitable for driving the machine, avoid loose clothing.
- Make sure you have the appropriate protective equipment for the task to be performed.
- Prolonged exposure to high noise levels may cause hearing problems. It is recommended to wear ear muffs to protect against excessive noise.
- Always face the driver's cab access when getting in and out of the lift truck and use the handle(s) provided for this purpose. Do not jump out of the machine.
- Remain alert at all times when using the machine. Do not listen to the radio or music using headphones or earphones.
- Never operate the lift truck when hands or feet are wet or soiled with greasy substances.
- For increased comfort, adjust the seat to your requirements and adopt the correct position in the driver's cab.



*Under no circumstances must the seat be adjusted while the machine is moving.*

- The operator must always be in his normal position in the driver's cab: Arms and legs, and generally any part of the body, should be kept inside the driver's cab of the machine.
- The safety belt must be worn and adjusted to the operator's size.
- The control units must never be used for any other than their intended purposes (e.g. Climbing onto or down from the machine, coat hanger, etc.).
- If the control components are fitted with a forced operation (lever lock) device, it is forbidden to leave the cab without first putting these controls in neutral.
- It is prohibited to carry passengers either on the machine or in the cab.

**C - ENVIRONMENT**

- Comply with site safety regulations.
- If you have to use the machine in a dark area or work at night, make sure it is equipped with work lights.
- During handling operations, make sure that no one is in the way of the machine and its load.
- Do not allow anybody to come near the working area of the machine or pass beneath an elevated load.
- The maximum slope on which the machine can be used in relation to the capacity of the brake is 20%.
- When using the lift truck on a transverse slope, before lifting the lifting structures, observe the instructions given in the paragraph: INSTRUCTIONS FOR HANDLING A LOAD: D - TRANSVERSE ATTITUDE OF THE MACHINE.
- Traveling on a longitudinal slope:
  - Drive and brake gently.

- Moving without load: Forks or attachment facing downhill.

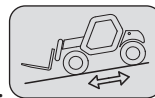

- Moving with load: Forks or attachment facing uphill.

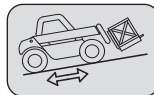

- Take into account the machine's dimensions and its load before trying to negotiate a narrow or low passageway.
- Never move onto a load bridge without having first checked:
  - That it is suitably positioned and made fast.
  - That the unit to which it is connected (wagon, truck, etc.) will not shift.
  - That this bridge is prescribed for the total weight of the machine, laden or unladen.
  - That this bridge is prescribed for the size of the machine.

- Never move onto a foot bridge, floor or freight lift, without being certain that they are suitable for the weight and size of the machine, laden or otherwise, and without having checked that they are in sound working order.
- Be careful in the area of loading bays, trenches, scaffolding, soft ground and manholes.
- Make sure the ground is stable and firm under the wheels and/or stabilizers before lifting or removing the load. If necessary, add appropriate wedging under the stabilizers.
- Make sure that the scaffolding, loading platform, pilings or ground is capable of bearing the load.
- Never stack loads on uneven ground, they may tip over.

**⚠ IMPORTANT ⚠**

*If the load or the attachment must remain above a structure for a prolonged period of time, there is the risk that it will bear on the structure as the lifting structure descends due to cooling of the oil in the cylinders.*

*To eliminate this risk:*

*- Regularly check the distance between the load or the attachment and the structure and readjust this if necessary.*

*- If possible use the machine at an oil temperature as close as possible to ambient temperature.*

- In the case of work near to overhead lines, ensure that the safety distance is sufficient between the machine's working area and the overhead line.

**⚠ IMPORTANT ⚠**

*Do not operate this machine during thunderstorms, snowstorms, periods of frost, or in hazardous weather conditions.*

**⚠ IMPORTANT ⚠**

*You must consult your local electrical supplier.*

*You could be electrocuted or seriously injured if you operate or park the machine too close to power lines.*

*In the event of high winds, do not carry out handling work that jeopardizes the stability of the machine and its load, particularly if the load catches the wind badly.*

- Prevent the fire risk associated with use in dusty and flammable conditions (e.g. straw, flour, sawdust, organic waste, etc.).

## **D - VISIBILITY**

- The safety of people within the machine's working area, as well as that of the machine itself and the operator, are dependent on good operator visibility of the machine's immediate surroundings in all situations and at all times.
- This machine has been designed to allow good operator visibility (direct or indirect by means of rear-view mirrors) of the immediate surroundings of the machine while driving with no load and with the boom in the transport position.
- Special precautions must be taken if the size of the load restricts visibility towards the front:
  - moving in reverse,
  - site layout,
  - assisted by a person directing the operation (while standing outside the machine's area of travel), making sure to keep this person clearly in view at all times,
  - in any case, avoid reversing over long distances.
- Certain special accessories may require the machine to travel with the boom in the raised position. In such cases, visibility on the right hand side is restricted, and special precautions must be taken:
  - site layout,
  - assisted by a person directing the operation (while standing outside the machine's area of travel).
  - replacement of a suspended load by a load on a pallet.
- If visibility of your road is inadequate, ask someone to assist by directing the operation (while standing outside the machine's area of travel), making sure to keep this person clearly in view at all times.
- Keep all components affecting visibility in a clean, properly adjusted state and in good working order (e.g. windshields, windows, windshield wipers, windshield washers, driving lights and worklights, rear-view mirrors).

## E - STARTING THE MACHINE

### SAFETY INSTRUCTIONS

#### **⚠ IMPORTANT ⚠**

*The machine must only be started up or maneuvered when the operator is sitting in the driver's cab with seat belt fastened and adjusted.*

- Never try to start the machine by pushing or towing it. Such an operation may cause severe damage to the transmission. If necessary, towing requires the transmission to be put in neutral (↩ 3 - MAINTENANCE).
- If using an emergency battery for start-up, use a battery with the same characteristics and respect battery polarity when connecting it. Connect at first the positive terminals before the negative terminals.

#### **⚠ IMPORTANT ⚠**

*Failure to respect polarity between batteries can cause serious damage to the electrical circuit.*

*The electrolyte in the battery may produce an explosive gas. Avoid flames and generation of sparks close to the batteries.*

*Never disconnect a battery while it is in charge.*

### INSTRUCTIONS

- Check the closing and locking of the hood(s).
- Check that the cab door is closed.
- Firmly press and hold down the brake pedal.
- Turn the ignition key to position (I) to switch on the machine and the engine preheat system.
- Check that the forward/reverse selector is in neutral, and that the manual parking brake is on.
- Check the fuel level on the dashboard gauge.
- Check the DEF (diesel exhaust fluid) level on the dashboard gauge. (depending on machine model)
- Turn the ignition key to position (III) for no longer than 15 seconds. The engine should then start. Release the ignition key and let the engine run at idling speed.
- Preheat the engine between each start attempt.
- Make sure all the signal lights on the control instrument panel are off.
- Check the longitudinal stability limiter and warning device (↩ 3 - MAINTENANCE).
- Do not use a machine that is non-compliant.
- Check all control instruments when the engine is warm and at regular intervals during use, so as to quickly detect any faults and to be able to correct them without any delay.
- If an instrument does not show the correct display, stop the engine and immediately carry out the necessary operations.

## F - OPERATING THE MACHINE

### SAFETY INSTRUCTIONS

#### **⚠ IMPORTANT ⚠**

*We would like to draw the operators' attention to the risks involved in using the machine, in particular:*

*- Risk of losing control.*

*- Risk of loss of lateral and frontal stability of the machine.*

*The operator must remain in control of the machine.*

*In the event of the machine overturning, do not try to leave the cab during the incident.*

**YOUR BEST PROTECTION IS TO STAY FASTENED IN THE CAB.**

- Observe the company's traffic regulations or, by default, the public highway code.
- Do not carry out operations which exceed the capacities of your machine or attachment.
- Always drive the machine with the forks or attachment in the transport position, i.e., 300 mm from the ground, the boom retracted and the forks carriage sloping backwards.
- Only carry loads which are balanced and properly anchored to avoid any risk of a load falling off.
- Ensure that pallets, cases, etc. are in good order and suitable for the load to be lifted.
- Familiarize yourself with the machine on the terrain where it will be used.
- Ensure that the brakes are working properly.
- The loaded machine must not travel at speeds in excess of 12 km/h.
- Drive smoothly at an appropriate speed for the operating conditions (land configuration, load on the machine).
- Do not use the hydraulic boom controls when the machine is moving.
- Never change the steering mode whilst driving.
- Ensure that visibility is adequate.
- Do not maneuver the machine with the boom in the raised position unless under exceptional circumstances and then with extreme caution, at very low speed and using gentle braking.
- Take bends slowly.

- In all circumstances make sure you are in control of your speed.
- On damp, slippery or uneven terrain, drive slowly.
- Brake gently, never abruptly.
- Only use the machine's forward/reverse selector from a stationary position and never do so abruptly.
- Do not drive with your foot on the brake pedal.
- Always remember that hydrostatic type steering is extremely sensitive to movement of the steering wheel, so turn it gently and not jerkily.
- Never leave the engine on when the lift truck is unattended.
- Do not leave the cab when the machine has a raised load.
- Look where you are going and always make sure you have good visibility along the route.
- Use the rear-view mirrors frequently.
- Drive around obstacles.
- Never drive on the edge of a ditch or steep slope.
- It is dangerous to use two machines simultaneously to handle heavy or bulky loads, since this operation requires particular precautions to be taken. It must only be used exceptionally and after risk analysis.
- The ignition switch has an emergency stop mechanism in case of an operating anomaly occurring in the case of machines not fitted with a punch-operated cut-out.

## INSTRUCTIONS

- Always drive the machine with the forks or attachment in the transport position, i.e., 300 mm from the ground, the telescopic arm retracted and the forks carriage sloping backward.
- For machines with gearboxes, use the recommended gear (↩ 2 - DESCRIPTION: INSTRUMENTS AND CONTROLS).
- Select the steering mode appropriate for the use and/or working conditions (↩ 2 - DESCRIPTION: INSTRUMENTS AND CONTROLS) (depending on machine model).
- Deactivate the parking brake.
- Shift the forward/reverse selector to the selected direction of travel and accelerate gradually until the machine moves off.

### **⚠ IMPORTANT ⚠**

***Starting and moving the machine on a slope may be a real hazard.***

***If the machine is parked or stopped, adhere scrupulously to the following instructions for moving it:***

***- Press the brake pedal.***

***- Release the parking brake.***

***- Engage the appropriate gear. (depending on machine model)***

***- Select forward or reverse direction.***

***- Ensure that there is no one or anything impeding the movement of the machine.***

***- Release the brake pedal and accelerate the engine.***

***The use of the machine loaded or with a trailer increases the risk. In this case, remain extremely vigilant.***

***Each braking system operates independently.***

***In an emergency, use the brake pedal and/or the manual parking brake to immobilize the machine.***

***With the engine off, release the manual parking brake only after restarting the engine and making sure that the brake pedal is functional.***

## G - STOPPING THE MACHINE

### SAFETY INSTRUCTIONS

- Never leave the ignition key in the machine during the operator's absence.
- When the machine is stationary, or if the operator has to leave his cab (even for a moment), place the forks or attachment on the ground, apply the parking brake and place the forward/reverse selector in neutral.
- Make sure that the machine is not stopped in any position that will interfere with the traffic flow and at less than one meter from the track of a railway.
- In the event of prolonged parking on a site, protect the machine from bad weather, particularly from frost (check the level of antifreeze), and close and lock all the machine accesses (doors, windows, cowls, etc.).

### INSTRUCTIONS

- Park the machine on level ground.
- When parking on slopes of less than 15%, position the machine perpendicular to the slope.
- The slope must not exceed 15%.
- Press and hold the brake pedal.
- Set the forward/reverse selector to neutral.
- Activate the parking brake.
- Release the brake pedal.
- The machine must be stationary before leaving the driver's cab.
- Fully retract the telescopic arm.
- Lower the forks or attachment to rest on the ground.
- When using an attachment with a grab or jaws, or a bucket with hydraulic opening, close the attachment fully.
- Before stopping the machine after intensive work, leave the engine idling for a few moments to allow the coolant and oil to lower the temperature of the engine and transmission. Do not forget this precaution, in the event of frequent stops or warm stalling of the engine, or else the temperature of certain parts will rise significantly due to the stopping of the cooling system, with the risk of badly damaging such parts.
- Stop the engine with the ignition switch and remove the key.
- Lock all the openings to the machine (doors, windows, cowls, etc.).
- Turn the battery cut-off to the "OFF" position in accordance with the recommendations (↖ 2 - DESCRIPTION).

## H - DRIVING THE MACHINE ON THE PUBLIC HIGHWAY

(or see current legislation in other countries)

### FRENCH ROAD TRAFFIC RULES

- The driving of non-type-approved "Tractor" machines on the public highway is subject to the provisions of the French Highway Code relating to special machines, defined in Article R.311-1 of the French Highway Code, in category B of the Equipment Order of November 20, 1969, which determines the procedures applicable to special machines. The machine must be fitted with an operating license plate.
- The driving of type-approved "Tractor" machines on the public highway is subject to the provisions of the French Highway Code relating to agricultural tractors, defined in Article R.311-1 of the French Highway Code. The machine must be licensed.
- The machine must be driven on the public highway in accordance with the instructions given in the manual supplied with the machine (Gross weight, Gross combination weight, towing load, axle loads, maximum speeds, etc. according to the type/version). The operator must be in possession of the machine's registration document.
- The operator must hold an HGV license, unless granted an exemption.
- When towing a trailer or agricultural equipment, the travel speed of the machine is limited to 25 km/h. In this case, a "25" disc must be affixed to the rear of the convoy.

### GERMAN ROAD TRAFFIC RULES

#### **⚠ IMPORTANT ⚠**

*For machines with the "Allgemeine Betriebserlaubnis" (general operating permit or ABE, in accordance with Article 20 of the StVZO "Straßenverkehrs-Zulassungsordnung"), follow the instructions below:*

- Disconnect the reversing sound alarm before using a machine with a general operating permit (ABE) on the public highway.

#### **⚠ IMPORTANT ⚠**

*Always reconnect the sound alarm before handling on private roads.*

- Before you use the machine for handling operations on private roads:
  - Make sure that the machine's reversing sound alarm is connected and working properly.
  - Perform a functional test by putting the machine into reverse gear.
  - The audible alarm sounds.
  - Do not use the machine if the audible alarm is not working. Check the audible alarm's connection and repeat the test. Consult your dealer if the problem persists.

### SAFETY INSTRUCTIONS

- Operators driving on the public highway must comply with current highway code legislation.
- The machine must comply with current road legislation. If necessary, there are optional solutions. Contact your dealer.

### INSTRUCTIONS

- Make sure the revolving light is in place, switch it on and verify its operation.
- Make sure the lights, turn signals and windshield wipers are working properly.
- Check the cleanliness of the machine's mudguards.
- Check the general cleanliness of the machine before driving on public roads.
- Switch off the worklights if the machine is fitted with them.
- Select the steering mode "HIGHWAY TRAFFIC" (↔ 2 - DESCRIPTION: INSTRUMENTS AND CONTROLS) (depending on machine model).
- Fully retract the telescopic arm and set the attachment approximately 300 mm off the ground.
- Put the frame leveling in the central position, i.e., the transverse axis of the axles parallel to the frame (depending on the machine model).
- Fully raise the stabilizers and turn the shoes inwards (depending on the machine model).

#### **⚠ IMPORTANT ⚠**

*Never coast in neutral (forward/reverse selector or gear lever in neutral or transmission cut-off button pressed) to preserve the machine's engine brake.*

*Failure to observe this instruction on a slope will lead to excessive speed, which may make the machine uncontrollable (steering, brakes) and cause serious mechanical damage.*

#### DRIVING THE MACHINE WITH A FRONT-MOUNTED ATTACHMENT

- You must comply with current regulations in your country, covering the possibility of driving on the public highway with a front-mounted attachment on your machine.
- If road legislation in your country authorizes circulation with a front-mounted attachment, you must at least:
  - Protect and report any sharp and/or dangerous edges on the attachment (↖ 4 - ADAPTABLE ATTACHMENTS AVAILABLE ON THE RANGE).
  - The attachment must not be loaded.
  - Make sure that the attachment does not mask the lighting range of the forward lights.
  - Make sure that current legislation in your country does not require other obligations.

#### OPERATING THE MACHINE WITH A TRAILER

- For using a trailer, observe the regulations in force in your country (maximum travel speed, braking, maximum weight of trailer, etc.).
- Do not forget to connect the trailer's electrical equipment to that of the machine.
- The trailer's braking system must comply with current legislation.
- If pulling a trailer with assisted braking, the tractor machine must be equipped with a trailer braking mechanism. In this case, do not forget to connect the trailer braking equipment to that of the machine.
- The vertical force on the towing hook must not exceed the maximum authorized by the manufacturer (consult the manufacturer's plate on your machine).
- The authorized gross vehicle weight must not exceed the maximum weight authorized by the manufacturer (↖ 2 - DESCRIPTION: SPECIFICATIONS).

**IF NECESSARY, CONSULT YOUR DEALER.**



## INSTRUCTIONS FOR HANDLING A LOAD

### A - CHOICE OF ATTACHMENTS

- Only attachments approved and authorized by MANITOU can be used on its machines.
- Make sure the attachment is suitable for the work to be done (◀ 4 - ADAPTABLE ATTACHMENTS AS OPTIONS ON THE RANGE).
- If the machine is equipped with the single sideshift attachment OPTION (TSDL), use only the authorized attachments (◀ 4 - ADAPTABLE ATTACHMENTS AS OPTIONS ON THE RANGE).
- Make sure the attachment is correctly installed and locked onto the machine carriage.
- Make sure that your machine attachments are working properly.
- Comply with the load chart limits for the machine for the attachment used.
- Do not exceed the rated capacity of the attachment.
- Never lift a slung load without the attachment provided for the purpose, as there is a risk of the sling slipping (◀ INSTRUCTIONS FOR HANDLING A LOAD: H - PICKING UP AND PUTTING DOWN A SUSPENDED LOAD).
- Do not handle loads suspended by straps directly on the forks (e.g.:big bags), as there is a risk of shearing on sharp edges. Use an attachment designed for this purpose.

### B - WEIGHT OF LOAD AND CENTER OF GRAVITY

- Before picking up a load, you must know its weight and its center of gravity.
- The longitudinal position of the center of gravity in relation to the heel of the forks (Fig. B1) is defined on the load chart for your machine (◀ 2 - DESCRIPTION: DIMENSIONS AND LOAD CHARTS). For loads with center of gravity exceeding this distance, contact your dealer.
- For irregular loads, determine the transverse center of gravity before any handling (fig. B2) and set it in the longitudinal axis of the machine.

#### ⚠ IMPORTANT ⚠

*It is forbidden to handle a load heavier than the effective capacity defined on the machine load chart.*

*For loads with a moving center of gravity (e.g. liquids), take account of the variations in the center of gravity in order to determine the load to be handled and be extra vigilant and careful to limit these variations as far as possible.*



### C - LONGITUDINAL STABILITY LIMITER AND WARNING DEVICE

This device gives an indication of the longitudinal stability of the machine, and limits hydraulic movements in order to ensure this stability, at least under the following operating conditions:

- when the machine is at a standstill,
  - when the machine is on firm, stable and consolidated ground,
  - when the machine is performing handling and placing operations.
- Move the boom very carefully when approaching the authorized load limit (◀ 2 - DESCRIPTION: INSTRUMENTS AND CONTROLS).
  - Always watch this device during handling operations.
  - If the "AGGRAVATING" hydraulic movements are cut off, perform only de-aggravating hydraulic movements in the following order (Fig. C): if necessary, raise the boom (1), retract the boom as far as possible (2) and lower the boom (3) to put down the load.

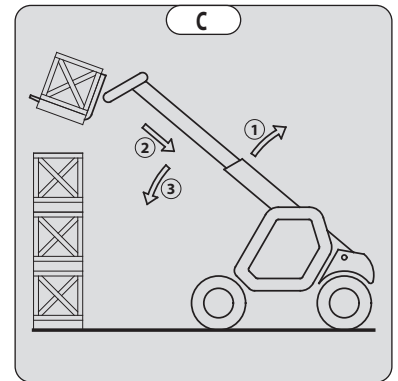

#### ⚠ IMPORTANT ⚠

*The instrument reading may be erroneous when the steering is at full lock or the rear axle is oscillated to its maximum extent.*

*Before lifting a load, ensure that the machine is not in any of these situations.*

## D - TRANSVERSE ATTITUDE OF THE MACHINE

Depending on machine model

The transverse attitude is the transverse slope of the frame with respect to the horizontal. Raising the boom reduces the machine's lateral stability. The machine's transverse attitude must be set with the boom in the down position as follows:

### 1 - MACHINE WITHOUT FRAME LEVELING USED ON TIRES

- Position the machine so that the bubble in the level is between the two lines (↩ 2 - DESCRIPTION: INSTRUMENTS AND CONTROLS).

### 2 - MACHINE WITH FRAME LEVELING USED ON TIRES

- Correct the tilt using the hydraulic control and check the horizontality with the spirit level. The bubble of the level must be between the two lines (↩ 2 - DESCRIPTION: INSTRUMENTS AND CONTROLS).

### 3 - MACHINE USED ON STABILIZERS

- Set the two stabilizers on the ground and raise the two front wheels of the machine (fig. D1).
- Correct the tilt using the stabilizers (Fig. D2) and check the horizontality with the spirit level. The bubble of the level must be between the two lines (↩ 2 - DESCRIPTION: INSTRUMENTS AND CONTROLS). In this position, the two front wheels must be off the ground.

## E - PICKING UP A LOAD ON THE GROUND

- Approach the machine perpendicular to the load, with the boom retracted and the forks in a horizontal position (fig. E1).
- Adjust the fork spacing and centering relative to the load to ensure stability (Fig. E2) (optional solutions exist, consult your dealer).
- Never lift a load with a single fork.

### ⚠ IMPORTANT ⚠

*Beware of the risks of trapping or squashing limbs when manually adjusting the forks.*

- Move the machine forward slowly (1) and bring the forks up to the stop in front of the load (Fig. E3). If necessary, slightly lift the boom (2) while picking up the load.
- Bring the load into the transport position.
- Tilt the load far enough backward to ensure stability (loss of load on braking or going downhill).

### FOR A NON-PALLETIZED LOAD

- Tilt the carriage (1) forwards and move the machine slowly forwards (2), to insert the fork under the load (Fig. E4) (chock the load if necessary).
- Continue to move the machine (2) forward, tilting the carriage (3) (fig. E4) backward to position the load on the forks and check the load's longitudinal and lateral stability.

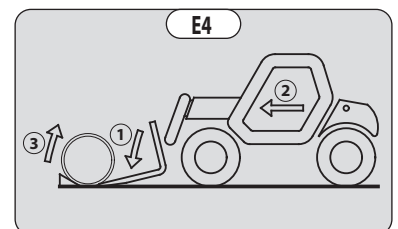
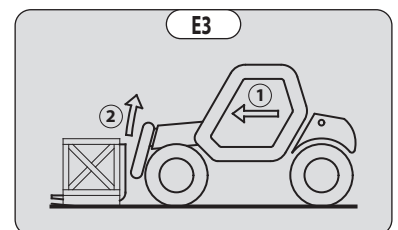
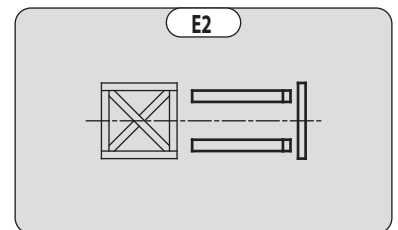
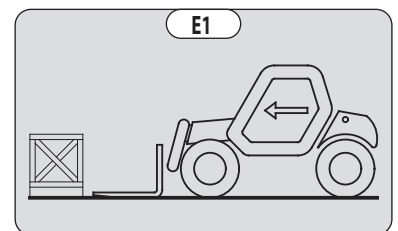
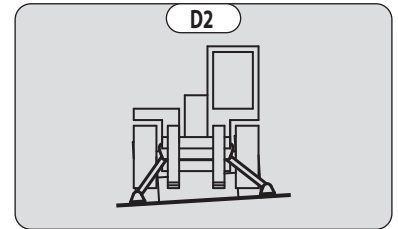
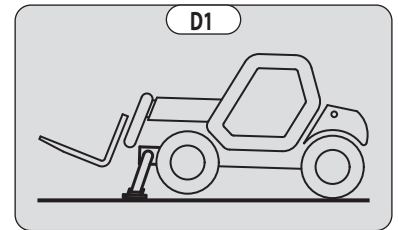

## F - PICKING UP AND PUTTING DOWN A HIGH LOAD ON TIRES

### ⚠ IMPORTANT ⚠

*You must not raise the boom if you have not checked the transverse attitude of the machine (← INSTRUCTIONS FOR HANDLING A LOAD D - TRANSVERSE ATTITUDE OF THE MACHINE).*

REMINDER: Make sure that the following operations can be performed with good visibility (← OPERATING INSTRUCTIONS UNLADEN AND LADEN: D - VISIBILITY).

### PICKING UP A HIGH LOAD ON TIRES

- Ensure that the forks will easily pass under the load.
- Raise and extend the boom (1) (2) until the forks are at the level of the load. If necessary, move the machine (3) forward (fig. F1), driving very slowly and carefully.
- Always remember to keep the distance necessary for inserting the forks under the load, between the stack and the machine (fig. F1) and use the shortest possible length of boom.
- Insert the forks under the load as far as they will go by alternately extending and lowering the boom (1) or, if necessary, moving the machine forward (2) (fig. F2). Activate the parking brake and place the forward/reverse selector in neutral.
- Lift the load slightly (1) and tilt the carriage (2) backwards to stabilize the load (Fig. F3).
- Tilt the load sufficiently backward to ensure its stability.
- Monitor the longitudinal stability limiter and warning device (← INSTRUCTIONS FOR HANDLING A LOAD: C - LONGITUDINAL STABILITY LIMITER AND WARNING DEVICE). If it is overloaded, set the load back down in the place from which it was picked up.
- If possible, lower the load without moving the machine. Raise the boom (1) to release the load, retract (2) and lower the jib (3) to set the load into transport position (fig. F4).
- If this is not possible, reverse the machine (1), maneuvering very gently and carefully to release the load. Retract (2) and lower the boom (3) to bring the load into the transport position (fig. F5).

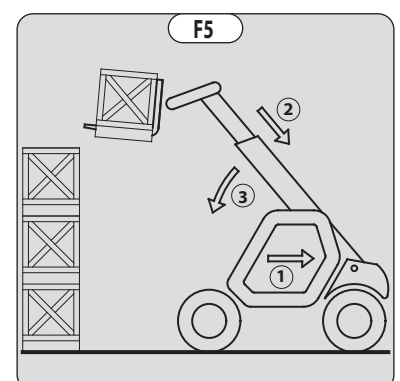
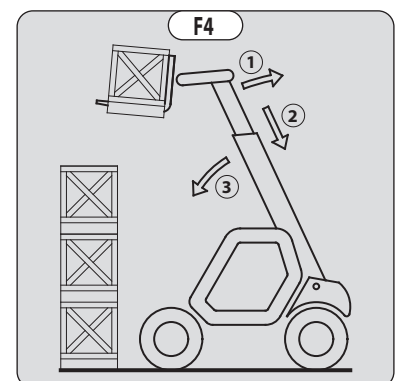
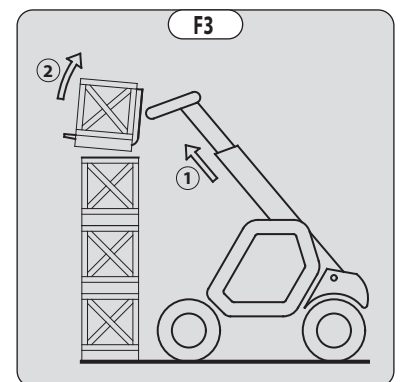
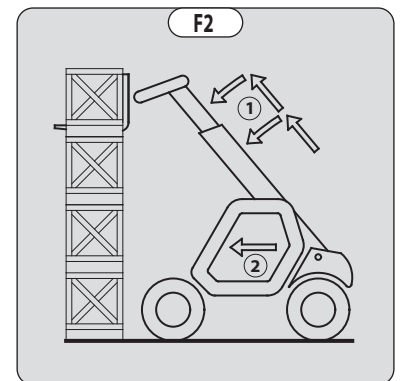
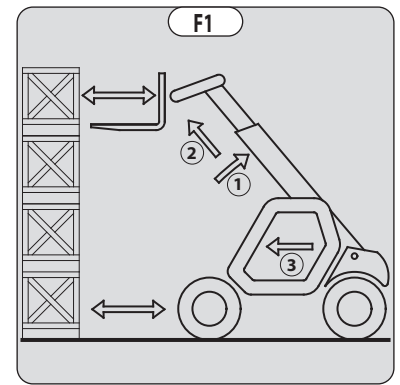

## PUTTING DOWN A HIGH LOAD ON TIRES

- Approach the load in the transport position in front of the stack (Fig. F6).
- Activate the parking brake and place the forward/reverse selector in neutral.
- Raise and extend the boom (1) (2) until the load is above the stack, while monitoring the longitudinal stability limiter and warning device (☞ INSTRUCTIONS FOR HANDLING A LOAD: C - LONGITUDINAL STABILITY LIMITER AND WARNING DEVICE). If necessary, move the machine (3) forward (fig. F7), driving very slowly and carefully.
- Place the load in a horizontal position and put it down on the pile by lowering and retracting the boom (1) (2) in order to position the load correctly (Fig. F8).
- If possible, release the forks by alternately retracting and raising the boom (1) (Fig. F9). Then set the forks into transport position.
- If this is not possible, reverse the machine (1), maneuvering very slowly and carefully to release the forks (fig. F10). Then set the forks into transport position.

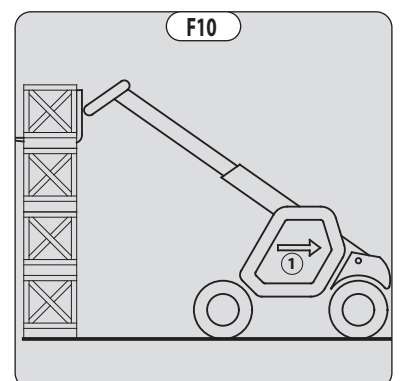
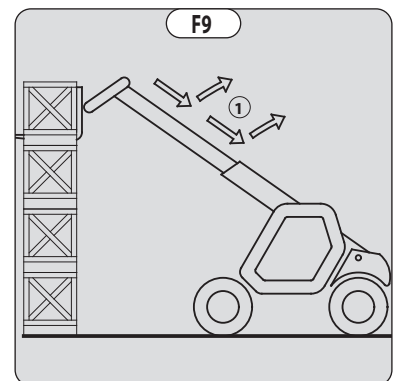
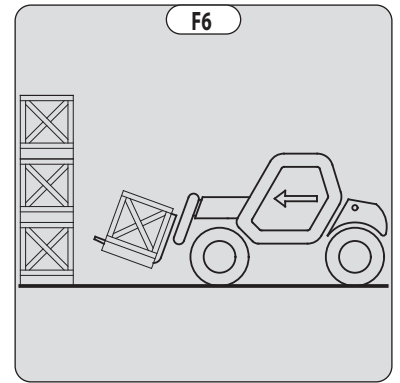

## G - PICKING UP AND PUTTING DOWN A HIGH LOAD ON STABILIZERS

Depending on machine model

### ⚠ IMPORTANT ⚠

*You must not raise the boom if you have not checked the transverse attitude of the machine (← INSTRUCTIONS FOR HANDLING A LOAD D - TRANSVERSE ATTITUDE OF THE MACHINE).*

REMINDER: Make sure that the following operations can be performed with good visibility (← OPERATING INSTRUCTIONS UNLADEN AND LADEN: D - VISIBILITY).

The stabilizers are used to optimize the machine's lifting performance (← 2 - DESCRIPTION: INSTRUMENTS AND CONTROLS).

POSITIONING THE STABILIZERS WITH THE FORKS IN TRANSPORT POSITION (UNLADEN AND LADEN)

- Set the forks in transport position in front of the elevation.
- Stay far enough away to allow the boom to be raised.
- Activate the parking brake and place the forward/reverse selector in neutral.
- Set the two stabilizers on the ground and lift the two front wheels of the machine (fig. G1), while maintaining its transverse stability.

RAISING THE STABILIZERS WITH THE FORKS IN TRANSPORT POSITION (UNLADEN AND LADEN)

- Raise both stabilizers fully and at the same time.

LOWERING THE STABILIZERS WITH JIB UP (UNLADEN AND LADEN)

### ⚠ IMPORTANT ⚠

*This operation must be exceptional and performed with great care.*

- Raise the boom and retract the telescopes completely.
- Set the machine in position in front of the elevation (fig. G2), moving very slowly and carefully.
- Activate the parking brake and place the forward/reverse selector in neutral.
- Move the stabilizers very slowly and gradually as soon as they are close to the ground or in contact with it.
- Lower the two stabilizers and lift the two front wheels of the machine (fig. G3). During this operation, transverse attitude must be permanently maintained: the bubble in the level must be kept between the two lines.

SETTING THE STABILIZERS WITH THE BOOM UP (UNLADEN AND LADEN)

### ⚠ IMPORTANT ⚠

*This operation must be exceptional and performed with great care.*

- Keep the boom raised and retract the telescopes completely (Fig. G3).
- Move the stabilizers very slowly and gradually as soon as they are in contact with the ground and when they leave the ground. During this operation, transverse attitude must be permanently maintained: the bubble in the level must be kept between the two lines.
- Raise both stabilizers completely.
- Deactivate the parking brake and reverse the machine (1) very slowly and carefully to release it and lower the forks (2) into transport position (fig. G4).

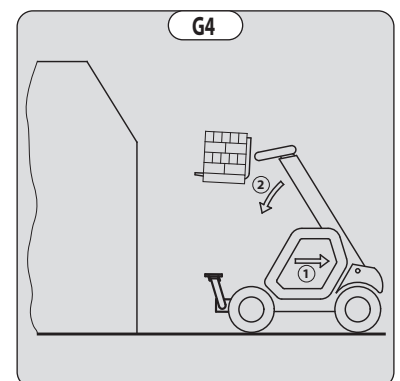
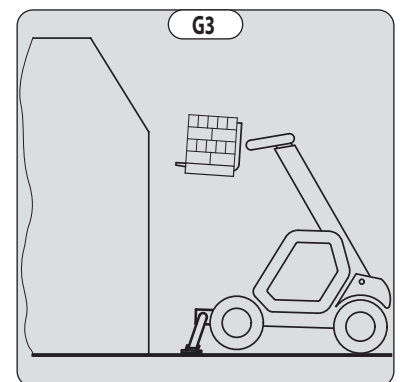
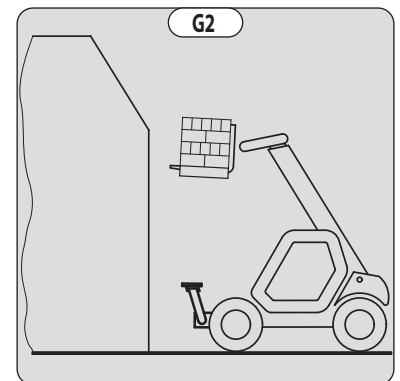
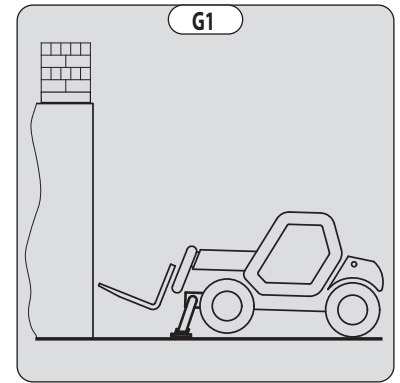

## PICKING UP A HIGH LOAD ON STABILIZERS

- Ensure that the forks will easily pass under the load.
- Check the position of the machine with respect to the load and make a test run, if necessary, without picking up the load.
- Raise and extend the boom (1) (2) until the forks are at the level of the load (Fig. G5).
- Bring the forks to the stop in front of the load by alternately extending and lowering the boom (1) (Fig. G6).
- Lift the load slightly (1) and tilt the carriage (2) backwards to stabilize the load (Fig. G7).
- Monitor the longitudinal stability limiter and warning device (← INSTRUCTIONS FOR HANDLING A LOAD: C - LONGITUDINAL STABILITY LIMITER AND WARNING DEVICE). If it is overloaded, set the load back down in the place from which it was picked up.
- If possible, lower the load without moving the machine. Raise the boom (1) to release the load, retract (2) and lower the jib (3) to set the load into transport position (fig. G8).

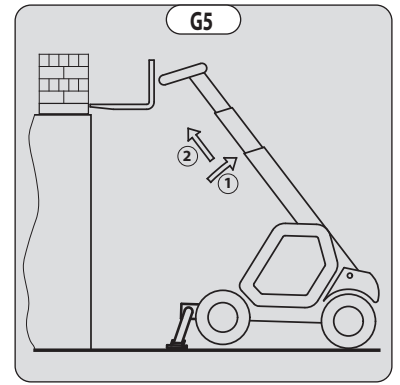

## SETTING DOWN A HIGH LOAD ON STABILIZERS

- Raise and extend the boom (1) (2) until the load is above the elevation (Fig. G9), while monitoring the longitudinal stability limiter and warning device (← INSTRUCTIONS FOR HANDLING A LOAD: C - LONGITUDINAL STABILITY LIMITER AND WARNING DEVICE).
- Position the load horizontally and release it by lowering and retracting the boom (1) (2) to position the load correctly (Fig. G10).
- Free the forks by alternately retracting and raising the boom (3) (Fig. G11).
- If possible, set the boom in transport position without moving the machine.

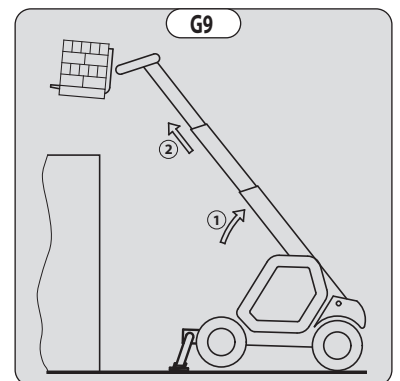

## H - PICKING UP AND PUTTING DOWN A SUSPENDED LOAD

### **IMPORTANT**

*Failure to follow the above instructions may lead the machine to lose stability and overturn.*

*MUST be used with a machine equipped with an operational hydraulic movement cut-off device.*



#### CONDITIONS OF USE

- The length of the sling or the chain shall be as short as possible to limit swinging of the load.
- Lift the load vertically along its axis, never by pulling sideways or lengthways.

#### HANDLING WITHOUT MOVING THE MACHINE

- Whether on stabilizers or on tires, the lateral attitude must not exceed 1% and the longitudinal attitude must not exceed 5%: the bubble of the level must be held at "0".
- Ensure that the wind speed is not higher than 10 m/s.
- Ensure that there is no one between the load and the machine.

#### I - TRAVELING WITH A SUSPENDED LOAD

- Before moving, inspect the terrain in order to avoid excessive slopes and cross-falls, bumps and potholes, or soft ground.
- Ensure that the wind speed is not higher than 36 km/h.
- The machine must not travel at more than 0.4 m/s (1.4 km/h, i.e. one quarter walking speed).
- Drive and stop the machine gently and smoothly to minimize swinging of the load.
- Carry the load a few centimeters above the ground (max. 30 cm) the shortest possible jib length. Do not exceed the offset indicated on the load chart. If the load begins to swing excessively, do not hesitate to stop and lower the jib to set down the load.
- Before moving the machine, check the longitudinal stability limiter and warning device ( 2 - DESCRIPTION: INSTRUMENTS AND CONTROLS), only the green LEDs and possible the yellow LEDs should be lit
- During transport, the lift truck operator must be assisted by a person on the ground (standing a minimum of 3 m from the load), who will limit swinging of the load using a bar or a rope. Ensure that this person is always clearly in view.
- The lateral attitude must not exceed 5%: the bubble in the level must be kept between the two "MAX" marks.
- The longitudinal attitude must not exceed 15% with the load facing uphill and 10% with the load facing downhill.
- The boom angle must not exceed 45°.
- If the first red LED of the longitudinal stability limiter and warning device ( 2 - DESCRIPTION: INSTRUMENTS AND CONTROLS) comes on while traveling, gently bring the machine to a halt and stabilize the load. Retract the telescope to reduce the offset of the load.

## INSTRUCTIONS FOR USE AS A LOADER

For agricultural-type machines (MLT range)

### A - LOADING

#### ⚠ IMPORTANT ⚠

*You must not raise the boom if you have not checked the transverse attitude of the machine (← INSTRUCTIONS FOR HANDLING A LOAD D - TRANSVERSE ATTITUDE OF THE MACHINE).*

REMINDER: Make sure that the following operations can be performed with good visibility (← OPERATING INSTRUCTIONS UNLADEN AND LADEN: D - VISIBILITY).

#### FILLING THE BUCKET

- Place the bottom of the bucket in a horizontal position, just in contact with the ground (1) (Fig. A1).
- Move forward gradually (2) while simultaneously raising the boom and tilting the bucket backwards (3), for improved filling and breakout (Fig. A1).
- Reverse the machine (1) very carefully and gently to free the bucket. Lower the boom (2) into the transport position (Fig. A2).

#### ⚠ IMPORTANT ⚠

*Tilt the bucket sufficiently back to avoid spilling product and ensure its stability (loss of product under braking).*

#### LOADING A TRAILER

- Approach the side of the trailer in the transport position (Fig. A3).
- Raise and extend the boom (1) (2) until the bucket is above the trailer, while monitoring the longitudinal stability limiter and warning device (← INSTRUCTIONS FOR HANDLING A LOAD: C - LONGITUDINAL STABILITY LIMITER AND WARNING DEVICE) (Fig. A4).
- Drive the machine forward (3) very carefully and gently so that the bucket empties its load in the center of the trailer (Fig. A4).
- Immobilize the machine with the brake pedal and put the reversing shift lever in neutral.

N.B.: Immobilizing the machine with the brake pedal means that the transmission should be in neutral. Failure to follow this recommendation may lead to overheating and damage to the brakes.

- Slowly discharge the product (4) (Fig. A4).
- Tilt the bucket backwards (1) and reverse the machine (2) very carefully and gently (Fig. A5).
- Retract (3) and lower the boom (4) into the transport position (Fig. A5).

### B - BACKFILLING

- Place the bottom of the bucket in a horizontal position, just in contact with the ground (1) (Fig. B1).
- Drive forward gradually (2). Once filled, the bucket will act as a leveling blade (Fig. B1).

#### ⚠ IMPORTANT ⚠

*When driving, beware of trenches as well as recently excavated and/or backfilled ground.*

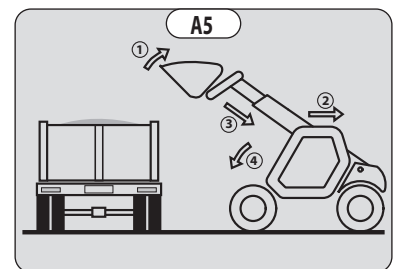
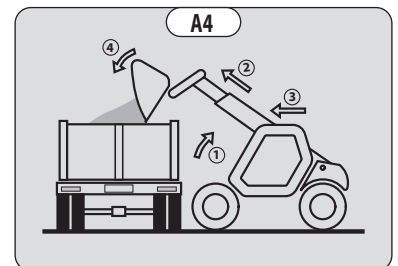
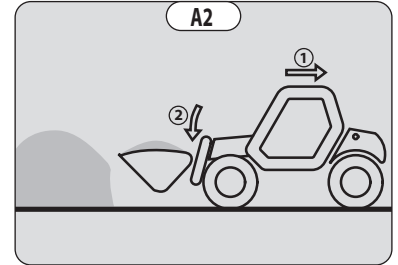
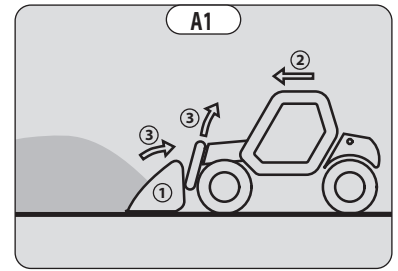

## **INSTRUCTIONS FOR USING THE MOBILE ELEVATING WORK PLATFORM**

---

For machines equipped with a MOBILE ELEVATING WORK PLATFORM

### **A - AUTHORIZATION FOR USE**

- Operation of the platform requires further authorization in addition to that of the machine.

### **B - SUITABILITY OF THE PLATFORM FOR THE JOB**

- Our machines fitted with mobile elevating work platforms are compliant with standard **EN 280** for Europe and standard **AS/NZS 1418.10:2011** for Australia, corresponding to the classification of Group C1 to C3 in accordance with this standard.
- MANITOU has ensured that this platform is suitable for use under the normal operating conditions provided in this operator's manual, with a STATIC test coefficient of 1.25 and a DYNAMIC test coefficient of 1.1 as specified in harmonized European standard **EN 280** for mobile elevating work platforms.
- Before commissioning, the company manager must make sure that the platform is appropriate for the work to be done, and perform certain tests (in accordance with current legislation).

### **C - PROVIDED ON THE PLATFORM**

- Wear suitable clothing when using the platform, avoid loose-fitting garments.
- Never use the platform with hands or shoes that are wet or soiled with greasy substances.
- Remain alert at all times when using the platform. Do not listen to the radio or music using headphones or earphones.
- MANITOU strongly recommends wearing a safety harness attached to an attachment point in the platform. Wearing a safety harness or other personal protection equipment against falls may be compulsory. Comply with local, government and national regulations in force, employer's safety rules and work site regulations .
- The safety harness or other personal protection equipment against falls must comply with local, government, and national regulations in force. They must be inspected in accordance with the regulations in force.
- The control units must never be used for any other than their intended purposes (e.g. Climbing onto or down from the machine, coat hanger, etc.).
- Safety helmets must be worn.
- The operator must always be in his normal position in the driver's cab: it is prohibited to have arms or legs, or generally any part of the body, outside the platform.
- Ensure that materials loaded onto the platform (pipes, cables, containers, etc.) cannot fall out. Do not pile these materials to the point where it is necessary to step over them.

## D - USING THE PLATFORM

- However experienced they may be, operators must acquaint themselves with the emplacement and operation of all control instruments prior to operating the platform.
- Check before use that the platform has been correctly assembled and locked onto the machine.
- Do not enter or exit the platform unless it is fully lowered.
- Always enter and exit the platform through the gate or using the sliding mid rails (depending on the model).
- Always enter and exit facing the interior of the platform.
- Always use both hands and one foot or both feet and one hand to enter and exit the platform.
- Make sure that the sliding intermediate cross members (depending on the model) are in the lower position and that the gate is properly closed (depending on the model) before using this platform.
- Do not attach the sliding mid rails in the high position.
- The platform should be operated in an area free of any obstructions or danger when it is lowered to the ground.
- The operator using the platform must be aided by someone on the ground with adequate training.
- You should stay within the limits set out in the platform load chart.
- The lateral constraints are limited (↔ 2 - DESCRIPTION: SPECIFICATIONS).
- It is strictly forbidden to suspend a load from the platform or the machine's boom without an attachment provided for the purpose (↔ INSTRUCTIONS FOR HANDLING A LOAD: H - PICKING UP AND PUTTING DOWN A SUSPENDED LOAD).
- The platform cannot be used as a crane or a lift for permanently transporting people or materials, nor as jacks or supports.
- The machine must not be moved with one (or more) person(s) on the platform.
- It is forbidden to transport people on the platform using the hydraulic controls in the machine's cab (except in case of rescue).
- The operator must not climb onto to off the platform when it is not on ground level (jib retracted and in the down position).
- The machine must not be fitted with unauthorized attachments that increase the windage of the assembly.
- Do not use ladders or improvised structures on the platform to gain extra height.
- Do not climb onto the rails of the platform to gain extra height.
- It is forbidden to use the platform on forks. The fork slots are only to, be used for storing the platform and not for lifting people under any circumstances.

**E - ENVIRONMENT**

- Respect a safety distance between power lines or live components and any part of the body, any conductive object or any part of the machine, unless the local, government and national applicable regulations, the safety rules of the employer or construction site regulations are more strict in terms of distance required.
- Allow for platform movement and swaying or sagging power lines.

**⚠ IMPORTANT ⚠**

*It is forbidden to use the platform close to electricity cables. Maintain the specified safe distances.*

RATED VOLTAGE (VOLTS)	SAFETY DISTANCE (METERS)
50 < U < 1000	2,30 M
1000 < U < 30000	2,50 M
30000 < U < 45000	2,60 M
45000 < U < 63000	2,80 M
63000 < U < 90000	3,00 M
90000 < U < 150000	3,40 M
150000 < U < 225000	4,00 M
225000 < U < 400000	5,30 M
400000 < U < 750000	7,90 M

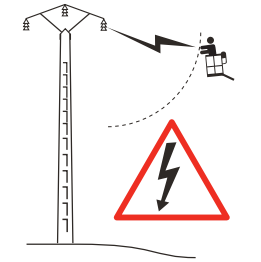

**⚠ IMPORTANT ⚠**

*It is strictly forbidden to use the platform when the wind speed exceeds 45 km/h.*

- To visually recognize this wind speed, refer to the empirical wind evaluation scale below:

BEAUFORT scale (wind speed at a height of 10 m on a flat site)						
Force	Type of wind	Speed (knots)	Speed (km/h)	Speed (m/s)	Effects on Land	Sea conditions
0	Calm	0 - 1	0 - 1	< 0.3	Smoke rises vertically.	Sea is like a mirror.
1	Light air	1 - 3	1 - 5	0.3 - 1.5	Smoke indicates direction of wind.	Ripples with appearance of scale, no foam crests.
2	Light breeze	4 - 6	6 - 11	1.6 - 3.3	Wind felt on face, leaves rustle.	Short wavelets, but pronounced.
3	Gentle breeze	7 - 10	12 - 19	3.4 - 5.4	Leaves and small twigs in constant motion.	Very small waves, crests begin to break.
4	Moderate breeze	11 - 16	20 - 28	5.5 - 7.9	Wind raises dust and loose pieces of paper; small branches are moved.	Small waves, becoming longer, numerous whitecaps.
5	Fresh breeze	17 - 21	29 - 38	8 - 10.7	Small trees in leaf begin to sway.	Wavelets form on inland waters; moderate waves, taking longer form.
6	Strong breeze	22 - 27	39 - 49	10.8 - 13.8	Large branches in motion, whistling heard in overhead wires, umbrella use becomes difficult.	Larger waves forming, whitecaps everywhere, some spray.
7	Near gale	28 - 33	50 - 61	13.9 - 17.1	Whole trees in motion, inconvenience felt when walking against the wind.	Sea heaps up; white foam from breaking waves begins to be blown in streaks along the direction of the wind.
8	Gale	34 - 40	62 - 74	17.2 - 20.7	Wind breaks twigs off trees; impedes progress.	Moderately high waves of greater length; edges of crests begin to break into spindrift.
9	Strong gale	41 - 47	75 - 88	20.8 - 24.4	Wind damages roofs (chimneys, slates, etc.).	High waves, crests of waves begin to topple, streaks of foam; reduced visibility.
10	Storm	48 - 55	89 - 102	24.5 - 28.4	Seldom experienced inland; trees uprooted; considerable structural damage occurs.	Very high waves; white streaks of foam; reduced visibility.
11	Violent storm	56 - 63	103 - 117	28.5 - 32.6	Very rare, widespread damage.	Exceptionally high waves able to hide medium sized ships from view, reduced visibility.
12	Hurricane	64 +	118 +	32.7 +	Devastating damage.	Sea completely white; air filled with foam and spray, very reduced visibility.

**F - MAINTENANCE**

**⚠ IMPORTANT ⚠**

*Your platform must be periodically inspected to ensure its continued compliance.*

*The frequency of this inspection is defined by the legislation in force in the country in which the platform is used.*

*In France, a general periodic inspection every 6 months (Decree of March 1, 2004).*

## INSTRUCTIONS FOR USING THE RADIO-CONTROL

For machines with RC radio control

### HOW TO USE THE RADIO-CONTROL

#### SAFETY INSTRUCTIONS

#### **⚠ IMPORTANT ⚠**

*It is prohibited to lift people in the platform using the radio-control.*

*It is prohibited to use the radio-control from the platform:*

- This radio-control consists of electronic and mechanical safety elements. It cannot receive commands from another transmitter because the internal encoding is unique to each radio-control.

#### **⚠ IMPORTANT ⚠**

*If it is used improperly or incorrectly, there is a risk of danger to:*

*- The physical and mental health of the user or others.*

*- The machine and other neighboring items.*

*Everyone working with this radio-control:*

*- Must be qualified in line with current regulations and trained accordingly.*

*- Must follow this instruction manual as closely as possible.*

- The system is used to control the machine remotely via radio waves. Commands are also transmitted if the machine is out of sight (behind an obstacle or a building for example), this is why:
  - After stopping the truck and removing the key switch (only possible when it is stationary), always place the transmitter in a safe, dry place.
  - Before performing any installation, servicing or repair work, always switch off power sources (in particular, electric welding devices and electric head units on hydraulic distributors must be disconnected at each section).
  - Never remove or alter the safety devices (such as the hand-guard frame, key, emergency stop button, etc.).

#### **⚠ IMPORTANT ⚠**

*Never drive the machine if it is not continuously and perfectly within view of the operator.*

- Before leaving the transmitter, the operator must make sure that it cannot be used by an unauthorized third person: either by removing the key button from the transmitter or locking it in an inaccessible place.
- The user must ensure that the instruction manual is accessible at all times and that operators have read and understood it.

#### INSTRUCTIONS

- Take up position in a stable place with no risk of slipping.
- Before using the transmitter, make sure there is nobody within the working area.
- Only use the transmitter with its carrying device or installed correctly on the platform.

#### **⚠ IMPORTANT ⚠**

*When you remove the transmitter, remove the accumulator and key button so that it cannot be used accidentally or deliberately by anyone else.*

#### PROTECTIVE DEVICES

- The machine will be immobilized within a maximum of 450 milliseconds (approx. 0.5 second):
  - If the emergency stop button of the transmitter is pressed (50 milliseconds), or that of the machine.
  - If the transmission distance of the radio waves is exceeded.
  - If the transmitter is faulty.
  - If an interfering radio signal is received from elsewhere.
  - If the accumulator is removed from its housing in the transmitter.
  - If the battery reaches the end of its autonomy.
  - If the transmitter is switched off by turning the key switch to the off position.
- These protective devices are provided for the safety of personnel and property and must never be modified, removed or bypassed in any way whatsoever!
- The hand-guard frame prevents external action on a joystick (e.g. if the transmitter is dropped, or if the operator leans on a guard-rail).
- An electronic safety device prevents radio transmission from being initiated if the joysticks are not mechanically and electrically at rest and if the internal combustion engine speed selector is not set to idle.

#### **⚠ IMPORTANT ⚠**

*In an emergency, press the transmitter emergency stop button immediately; then follow the manual's instructions (→ 2 - DESCRIPTION: INSTRUMENTS AND CONTROLS).*

# MACHINE MAINTENANCE INSTRUCTIONS

## GENERAL INSTRUCTIONS

### ⚠ IMPORTANT ⚠

Carefully read and understand this operator's manual before any operation on this machine.

Carry out all repairs immediately, even if the repairs concerned are minor.

Repair all leaks immediately, even if the leak concerned is minor.

Be careful of the risk of burns and splashing (exhaust, radiator, engine, hydraulic oil, etc.).

- Make sure the area is adequately ventilated before starting up the machine.
- Wear clothes suitable for the maintenance of the machine. Avoid wearing jewelry and loose clothes. Tie back and protect your hair, if necessary.
- Stop the engine and remove the ignition key before carrying out any work.

## PLACING THE JIB SAFETY WEDGE

- The machine is equipped with a boom safety wedge (↖ 2 - DESCRIPTION: INSTRUMENTS AND CONTROLS) that must be installed on the lifting cylinder rod when working beneath the boom.
- Boom retracted without forks or attachments.

ACCORDING TO INSTALLATION

### FITTING THE WEDGE

- Fully raise the jib.
- Place the safety wedge 1 on the rod of the lifting cylinder and secure with the rod 2 and the pin 3.
- Slowly lower the jib then stop the hydraulic movements before it comes into contact with the wedge.

### REMOVING THE WEDGE

- Fully raise the jib.
- Remove the pin and the rod.
- Return the safety wedge to the storage location provided on the machine.

### ⚠ IMPORTANT ⚠

Only use the wedge supplied with the machine.

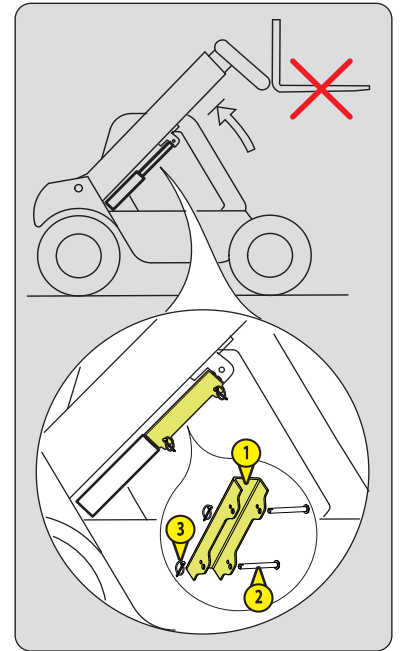

ACCORDING TO INSTALLATION

### FITTING THE WEDGE

- Fully raise the jib.
- Loosen the thumbwheels 1.
- Assemble the parts of the safety wedge 2 around the cylinder rod and lock with the pins 3.

NOTE: the stop flats 4 of the safety wedge must be located towards the bottom of the lifting cylinder 5.

- Slowly lower the jib then stop the hydraulic movements before it comes into contact with the wedge.

### REMOVING THE WEDGE

- Fully raise the jib.
- Remove the pins 3.
- Put the parts of the safety wedge 2 back on the machine and lock them with the thumbwheels 1.
- Replace the pins 3 on the parts of the safety wedge.

### ⚠ IMPORTANT ⚠

Only use the wedge supplied with the machine.

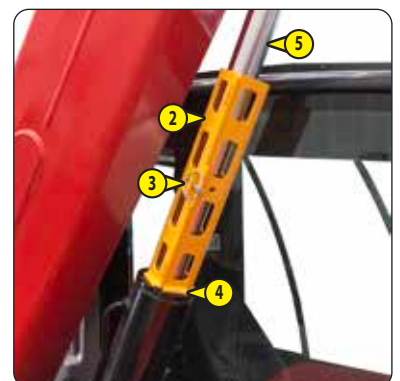
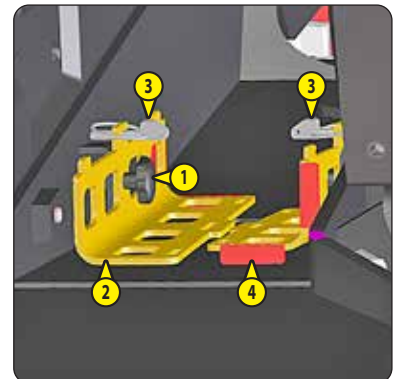

## MAINTENANCE

---

- Perform the periodic service (↩ 3 - MAINTENANCE) to keep your machine in good working order. Failure to perform periodic maintenance may invalidate the contractual warranty.

### MAINTENANCE LOGBOOK

- The maintenance operations carried out in accordance with the recommendations given in section 3 - MAINTENANCE and the other inspection, servicing or repair operations or modifications performed on the machine shall be recorded in a maintenance logbook.
- The entry for each operation should include the date of the work, the names of the individuals or companies having performed them, the type of operation and its frequency, if applicable.
- If machine elements are replaced, the part numbers of these elements shall be indicated.

## LUBRICANT AND FUEL LEVELS

---

- Use the recommended lubricants (never use contaminated lubricants).
- Do not fill the fuel tank when the engine is running.
- Only fill up the fuel tank in areas specified for this purpose.
- Do not fill the fuel tank to the maximum level.
- Do not smoke or approach the machine with a flame when the fuel tank is open or is being filled.

## HYDRAULICS

---

- Any work on the load handling hydraulic circuit is forbidden except for the operations described in chapter: 3 - MAINTENANCE.
- Do not attempt to loosen unions, hoses or any hydraulic component with the circuit under pressure.



**COUNTERBALANCE VALVE:** *it is dangerous to change the setting or remove the counterbalance valves or safety valves which may be fitted to the cylinders of your machine.*

**HYDRAULIC ACCUMULATOR:** *dismantling hydraulic accumulators and their pipes which may be fitted on your machine is dangerous. Such operations must only be performed by approved personnel (consult your dealer).*

## ELECTRICITY

---

- Do not short-circuit the starter relay to start the engine. If the forward/reverse selector is not in neutral and the parking brake is not on, the machine may suddenly start to move.
- Do not place metal items on the battery.
- Disconnect the battery before working on the electrical circuit.

## WELDING ON THE MACHINE

---



**Welding operations on the machine for the purposes of maintenance or repairs must only be carried out by people authorized by MANITOU.**

- Disconnect the battery before any welding operations on the machine.
- When carrying out electric welding work on the machine, connect the negative cable from the equipment directly to the part being welded so as to avoid very high current passing through the alternator.
- Never carry out welding or work which gives off heat on an assembled tire. The heat would increase the pressure which could cause the tire to explode.
- If the machine is equipped with an electronic control unit, disconnect it before starting to weld so as to avoid the risk of causing irreparable damage to electronic components.

## WASHING THE MACHINE

---

### **⚠ IMPORTANT ⚠**

*When washing with a high pressure cleaner, avoid the engine air intakes, the cylinder rod wiper seals, the hinges, the structural components and the electrical connections, etc.*

- Clean the machine or at least the area concerned before any intervention.
- Remember to close and lock all openings on the machine (doors, windows, cowls, etc.).
- If necessary, protect against penetration of water, steam or cleaning agents, components susceptible of being damaged, particularly electrical components and connections and the injection pump.
- Clean the machine of any traces of fuel, oil or grease.

## TRANSPORTING THE MACHINE

---

### **⚠ IMPORTANT ⚠**

*Transporting the machine involves real risks for the operator and others involved.*

- Towing, winching, slinging or transporting the machine (⚠ 3 - MAINTENANCE).

## PROLONGED MACHINE SHUTDOWN

### INTRODUCTION

---

### **⚠ IMPORTANT ⚠**

*Procedures to follow for long duration standstill and for bringing back the machine into service must be performed by your dealership.*

*This period of long duration standstill must not exceed 12 months.*

*After 12 months, repeat the procedures for putting the machine back into service and long-term shutdown.*

The recommendations below are intended to prevent the machine from being damaged when it is not used for a period of more than 3 months.

### PREPARATION OF THE MACHINE

---

- Clean the machine thoroughly.
- Check and repair any fuel, oil, water or air leaks.
- Replace or repair any worn or damaged parts.
- Wash the painted surfaces of the machine in clear and cold water and wipe them.
- Touch up the paintwork if necessary.
- Lower the lifting structure fully.
- Retract the telescopic arms.
- Release the pressure in the hydraulic circuits.
- Shut down the machine.

### DEF (Diesel Exhaust Fluid) TANK

---

Depending on machine model

- Drain down and rinse the DEF (Diesel Exhaust Fluid) tank.
- Replace the "DEF" (Diesel Exhaust Fluid) feed pump filter (⚠ 3 - MAINTENANCE).
- Slowly fill the tank with new DEF up to the bottom of the filler neck.
- Start up the machine to pressurize the circuit and bring it up to working temperature, then shut down the engine.
- If necessary, top up the tank.

## PROTECTING THE ENGINE

---

- Contact your dealer to obtain the procedure for protecting the inside of the engine (use of protection product).
- Fill the tank with fuel (<img alt="arrow icon" data-bbox="245 85 260 100"/> 3 - MAINTENANCE).
- Replace the engine oil and oil filter (<img alt="arrow icon" data-bbox="245 100 260 115"/> 3 - MAINTENANCE).
- Replace the coolant (<img alt="arrow icon" data-bbox="245 115 260 130"/> 3 - MAINTENANCE).
- Leave the engine running at idling speed for a few minutes, then switch off.
- Run the engine for a short time so that the oil and cooling liquid circulate inside.
- Disconnect the battery and store it in a safe place away from the cold, after charging it to maximum capacity.
- Block the outlet with waterproof adhesive tape.
- Remove the drive belts and store them in a safe place.
- Disconnect the engine cut-off solenoid on the injection pump and carefully insulate the connection.

## MACHINE PROTECTION

---

Place the machine on level ground.

- Set the machine on axle stands so that the tires are off the ground.
- Deactivate the parking brake (*depending on machine model*).
- Protect cylinder rods which will not be retracted from corrosion.
- Wrap the wheels.

N.B.: If the machine is to be stored outdoors, cover it with a waterproof tarpaulin.

## RETURNING THE MACHINE TO SERVICE

---



*Make sure the area is adequately ventilated before starting up the machine.*

- Remove the waterproof adhesive tape from all the orifices.
- Remove the protection from the cylinder rods and wheels.
- Refit and reconnect the battery.
- Activate the parking brake and remove the axle stands.
- Perform the daily maintenance operations (<img alt="arrow icon" data-bbox="245 480 260 495"/> 3 - MAINTENANCE).
- Perform the weekly maintenance operations (<img alt="arrow icon" data-bbox="245 495 260 510"/> 3 - MAINTENANCE).
- Drain and clean the fuel tank (<img alt="arrow icon" data-bbox="245 510 260 525"/> 3 - MAINTENANCE).
- Fill the fuel tank with clean diesel filtered through the filler port.
- Replace the fuel filter (<img alt="arrow icon" data-bbox="245 525 260 540"/> 3 - MAINTENANCE).
- Replace the fuel pre-filter (<img alt="arrow icon" data-bbox="245 540 260 555"/> 3 - MAINTENANCE) (*depending on the model of machine*).
- Drain and rinse the DEF tank (*depending on the machine model*).
- Top up, slowly fill the tank with new "DEF" (Diesel Exhaust Fluid) up to the bottom of the filler neck (*depending on the machine model*).
- Refit and set the tension in the belts. (<img alt="arrow icon" data-bbox="245 605 260 620"/> 3 - MAINTENANCE).
- Turn the engine over with the starter, to allow the oil pressure to rise.
- Reconnect the engine cut-off solenoid.
- Lubricate the machine completely (<img alt="arrow icon" data-bbox="245 645 260 660"/> 3 - MAINTENANCE).
- Start up the machine, following the operating and safety instructions (<img alt="arrow icon" data-bbox="245 660 260 675"/> OPERATING INSTRUCTIONS UNLADEN AND LADEN).
- Perform all the lifting structure's hydraulic movements up to the end position for each cylinder.

## DISPOSING OF THE MACHINE



*Consult your dealer before disposing of the machine.*

### RECYCLING OF MATERIALS

---

#### METALS

- Metals are 100% recoverable and recyclable.

#### PLASTICS

- Plastic parts are identified with a marking in accordance with current regulations.
- A limited range of materials is used to simplify the recycling process.
- The majority of the plastic components are made of "thermoplastic" plastics, which are easily recycled by melting, granulating or grinding.

#### RUBBER

- Tires and seals can be ground for use in cement manufacture or to obtain reusable granules.

#### GLASS

- Glass items can be removed and collected for processing by glaziers.

### ENVIRONMENTAL PROTECTION

---

By entrusting the maintenance of your machine to the MANITOU network, the risk of pollution is limited and the contribution to environmental protection is made.

#### WORN OR DAMAGED PARTS

- Do not dump them in the countryside.
- MANITOU and its network have signed-up to a scheme of environmental protection through recycling.

#### USED OIL

- The MANITOU network organizes the collection and processing of used oil.
- By handing over your waste oil to MANITOU, the risk of pollution is limited.

#### USED BATTERIES

- Do not throw away batteries, as they contain metals that are harmful for the environment.
- Return them to the MANITOU network or any other approved collection point.

N.B.: MANITOU aims to manufacture machines that provide the best performance and limit polluting emissions.

# ***2 - DESCRIPTION***



## 2 - DESCRIPTION

<b><u>CE DECLARATION OF CONFORMITY</u></b>	<b>2-4</b>
<b><u>CE DECLARATION OF CONFORMITY (TRACTOR TYPE APPROVAL)</u></b>	<b>2-6</b>
<b><u>SAFETY PLATES AND STICKERS</u></b>	<b>2-8</b>
<b><u>IDENTIFICATION OF THE LIFT TRUCK</u></b>	<b>2-12</b>
<b><u>CHARACTERISTICS</u></b> MLT 630 105D V ST4 S2	<b>2-16</b>
<b><u>CHARACTERISTICS</u></b> MLT 630 105D V CP ST4 S2	<b>2-20</b>
<b><u>CHARACTERISTICS</u></b> MLT 730 115D V ST4 S1	<b>2-24</b>
<b><u>CHARACTERISTICS</u></b> MLT 730 115D V CP ST4 S1	<b>2-28</b>
<b><u>TYRES</u></b> MLT 630 ...	<b>2-32</b>
<b><u>TYRES</u></b> MLT 730 ...	<b>2-34</b>
<b><u>DIMENSIONS AND LOAD CHARTS</u></b> MLT 630 105D V ST4 S2	<b>2-36</b>
<b><u>DIMENSIONS AND LOAD CHARTS</u></b> MLT 630 105D V CP ST4 S2	<b>2-38</b>
<b><u>DIMENSIONS AND LOAD CHARTS</u></b> MLT 730 115D V ST4 S1	<b>2-40</b>
<b><u>DIMENSIONS AND LOAD CHARTS</u></b> MLT 730 115D V CP ST4 S1	<b>2-42</b>
<b><u>VISIBILITY</u></b> MLT 630 105D V ST4 S2	<b>2-44</b>
<b><u>VISIBILITY</u></b> MLT 630 105D V CP ST4 S2	<b>2-46</b>
<b><u>VISIBILITY</u></b> MLT 730 115D V ST4 S1	<b>2-48</b>
<b><u>VISIBILITY</u></b> MLT 730 115D V CP ST4 S1	<b>2-50</b>
<b><u>INSTRUMENTS AND CONTROLS</u></b>	<b>2-52</b>
<b><u>TOWING DEVICE</u></b>	<b>2-84</b>
<b><u>DESCRIPTION AND USE OF THE OPTIONS</u></b>	<b>2-90</b>

1) **DÉCLARATION "CE" DE CONFORMITÉ (originale)**  
**"EC" DECLARATION OF CONFORMITY (original)**

2) Constructeur, *Manufacturer* : **MANITOU BF**

3) Adresse, *Address* : **430, RUE DE L'AUBINIÈRE - B.P 10249  
44158 - ANCENIS - CEDEX - FRANCE**

4) Titulaire de dossier technique, *Holder of the technical file* : **MANITOU BF**

3) Adresse, *Address* : **430, RUE DE L'AUBINIÈRE - B.P 10249  
44158 - ANCENIS - CEDEX - FRANCE**

5) Le constructeur déclare que la machine décrite ci-après, *The manufacturer declares that the machine described below* :

<b>MLT 630 105D V ST4 S2</b>	<b>52000947/00000</b>	<b>N° &gt;MAN00000E000000000&lt;</b>
<b>MLT 630 105D V CP ST4 S2</b>	<b>52000946/00000</b>	<b>N° &gt;MAN00000E000000000&lt;</b>
<b>MLT 730 105D V ST4 S1</b>	<b>52000970/00000</b>	<b>N° &gt;MAN00000E000000000&lt;</b>
<b>MLT 730 105D V CP ST4 S1</b>	<b>52000969/00000</b>	<b>N° &gt;MAN00000E000000000&lt;</b>

6) Est conforme aux directives suivantes et à leurs transpositions en droit national (si applicables), *Complies with the following directives and their transpositions into national law (if applicable)* :

**2006/42/CE**

7) Pour les machines annexe IV, *For annex IV machines* :

8) Numéro d'attestation, *Certificate number* :

9) Organisme notifié, *Notified body* : -

**2000/14/CE + 2005/88/CE**

10) Procédure appliquée, *Applied procedure* :

9) Organisme notifié, *Notified body* :

11) Niveau de puissance acoustique, *Sound power level* :

12) Mesuré, *Measured* : dB (A)

13) Garanti, *Guaranteed* : dB (A)

**2004/108/CE jusqu'au 19/04/2016 et 2014/30/UE à partir du 20/04/2016**

14) Normes harmonisées utilisées, *Harmonised standards used* :

15) Normes ou dispositions techniques utilisées, *Standards or technical provisions used* :

16) Fait à, *Done at* :

17) Date, *Date* :

18) Nom du signataire, *Name of signatory* :

19) Fonction, *Function* :

20) Société, *Company* :

21) Signature, *Signature* :

**bg :** (1) *ЕОД декларация за съответствие (оригинал)*, (2) Производител, (3) Адрес, (4) Притежател на техническото досие, (5) Производителят декларира, че описаната по-долу машина, (6) Е в съответствие със следните директиви и тяхното транспониране в националното законодателство (ако е приложимо), (7) Приложение IV относно машините, (8) Номер на сертификата, (9) Нотифициран орган, (10) Приложена процедура, (11) Ниво на силата на звука, (12) Измерено, (13) Гарантирано, (14) Използвани хармонизирани стандарти, (15) Използвани стандарти или технически разпоредби, (16) Изработено в, (17) Дата, (18) Име на подписаното лице, (19) Длъжност, (20) Фирма, (21) Подпис

**cs :** (1) *ES prohlášení o shodě (původní)*, (2) Výrobce, (3) Adresa, (4) Držitel technické dokumentace, (5) Výrobce prohlašuje, že zařízení popsané níže, (6) Je v souladu s následujícími směrnici a a směrnici transponovanými do vnitrostátního práva (je-li relevantní), (7) Pro stroje v příloze IV(8) Číslo certifikátu, (9) Notifikační orgán, (10) Použitý postup, (11) Úroveň hluku (12) Naměřená, (13) Zaručená, (14) Použitě harmonizované normy, (15) Použitě normy nebo technické předpisy(16) Místo (17) Datum (18) Jméno podepsaného, (19) Funkce, (20) Společnost, (21) Podpis

**da :** (1) *EF Overensstemmelseserklæring (original)*, (2) Producent, (3) Adresse, (4) Indehaver af det tekniske dossier, (5) Producenten erklærer, at maskinen, der er beskrevet nedenfor, (6) overholder nedenstående direktiver og disse gennemførelse til national ret (hvis det er relevant), (7) For maskiner under bilag IV, (8) Certifikatnummer, (9) Bemyndigede organ, (10) Anvendt procedure, (11) Lydeffektniveau, (12) Målt, (13) Garanteret, (14) Anvendte harmoniserede standarder, (15) Standarder eller tekniske regler, (16) Nummeret i, (17) Dato, (18) Underskrivers navn, (19) Funktion, (20) Firma, (21) Underskrift.

**de :** (1) *EG-Konformitätserklärung (original)*, (2) Hersteller, (3) Adresse, (4) Inhaber des technischen Dokuments, (5) Der Hersteller erklärt, dass die nachstehend beschriebene Maschine (6) den folgenden Richtlinien und deren Umsetzung in die nationale Gesetzgebung entspricht (falls anwendbar), (7) Für die Maschinen laut Anhang IV, (8) Bescheinigungsnummer, (9) Benannte Stelle, (10) Angewandtes Verfahren, (11) Schalleistungspegel, (12) Gemessen, (13) Gewährleistet, (14) angewandte harmonisierte Normen, (15) angewandte sonstige technische Normen und Bestimmungen, (16) Ausgestellt in, (17) Datum, (18) Name des Unterzeichners, (19) Funktion, (20) Gesellschaft, (21) Unterschrift.

**el :** (1) *Δηλώση συμμόρφωσης ΕΕ (πρωτότυπο)*, (2) Κατασκευαστής, (3) Διεύθυνση, (4) Κάτοχος του τεχνικού φακέλου, (5) Ο κατασκευαστής δηλώνει ότι το μηχάνημα που περιγράφεται παρακάτω, (6) Συμμορφώνεται με τις εθνικές οδηγίες και τις προσαρμογές τους στο εθνικό δίκαιο (κατά περίπτωση), (7) Για τα μηχανήματα του παραρτήματος IV, (8) Αριθμός πιστοποίησης, (9) Διοικητικό φορέας, (10) Εφαρμοζόμενη διαδικασία, (11) Στάθμη ηχητικής ισχύος, (12) Καταμετρημένο, (13) Εγγυημένο, (14) Εναρμονισμένα πρότυπα που χρησιμοποιούνται, (15) Πρότυπο ή τεχνικοί κανόνες που χρησιμοποιούνται, (16) Τόπος, (17) Ημερομηνία, (18) Όνομα του υπογράφοντος, (19) Ιδιότητα, (20) Εταιρεία, (21) Υπογραφή

**es :** (1) *Declaración CE de conformidad (original)*, (2) Fabricante, (3) Dirección, (4) Titular del expediente técnico, (5) El fabricante declara que la máquina que se describe a continuación, (6) Cumple con las siguientes directivas y sus transposiciones a la legislación nacional (en caso oportuno), (7) Para las máquinas anexo IV, (8) Número de certificación, (9) Organismo notificado, (10) Procedimiento aplicado, (11) Nivel de potencia acústica, (12) Medido, (13) Garantizado, (14) Normas armonizadas utilizadas, (15) Otras normas o especificaciones técnicas utilizadas, (16) Hecho en, (17) Fecha, (18) Nombre del signatario, (19) Cargo, (20) Empresa, (21) Firma.

**et :** (1) *EÜ vastavusdeklaratsioon (algupärane)*, (2) Tootja, (3) Aadress, (4) Tehnilise dokumentatsiooni vastaja, (5) Tootja kinnitab, et allpool kirjeldatud seade, (6) On vastavuses järgmistele direktiivide ja nende reguleerimisesse õigusse ülevõtmiseks vastuvõetud õigusaktidega (kui on kohaldatav), (7) IV lisas loetletud seadmete puhul, (8) Tunnistuse number, (9) Serifitseerimisasutus, (10) Kohaldatav menetlus, (11) Akustilise võimsuse tase, (12) Mõeldud, (13) Tagatud, (14) Vastab kehtivatele ühistule standarditele, (15) Vastab muudele kehtivatele standarditele ja tehnilistele normidele, (16) Väljaandmise koht, (17) Väljaandmise aeg, (18) Allkirjastaja nimi, (19) Amet, (20) Ettevõtte, (21) Allkiri

**fi :** (1) *EY-vaatimustenmukaisuusvakuutus (alkuperäinen)*, (2) Valmistaja, (3) Osoite, (4) Teknisten asiakirjojen haltaja, (5) Valmistaja ilmoittaa, että alla kuvattu laite, (6) Täyttää seuraavien direktiivien sekä niitä vastaavien kansallisten sääntöjen vaatimukset (tarvittaessa), (7) Liitteen IV laitteiden osalta, (8) Todistusnumero, (9) Ilmoittaja laitos, (10) Käytetty menetelmä, (11) Äänen tehotaso, (12) Mittattu, (13) Taattu, (14) Käytetyt yhdenmukaistetut standardit, (15) Käytetyt tekniset standardit tai säännökset, (16) Paikka, (17) Aika, (18) Allekirjoittajan nimi, (19) Toimi, (20) Yritys, (21) Allekirjoitus.

**ga :** (1) *Dearbháil comhréireachta « CE » (tuisceán)*, (2) Déantóir, (3) Seoladh, (4) Sealbóir an chomhaid theicniúil, (5) Dearbháilern an déantóir go ndéanann an t-inneal ar a bhíll cur síos thíos, (6) Cloíonn sé le na treochra seo a leanas agus lena d'úsáid isteach i ndáil náisiúnta (más cuí), (7) Le haghaidh innlín an aghaidh IV, (8) Uimhir teastais, (9) Comhábhaí a d'ugraíógra dó, (10) Nós imeachta a cuireadh i bhfeidhm, (11) Leibhéal cumhachta na fuaimne, (12) Tomhasa, (13) Réitithe, (14) Caighdeán chomhábhaíthe a úsáideadh, (15) Caighdeán nó fóirleacha teicniúla a úsáideadh, (16) Ama dhéanamh ag, (17) Dáta, (18) Ainm an tsíntheora, (19) Feidhmeannas, (20) Comhábhaí (21) Síniú.

**hr :** (1) *EK deklaracija o usklađenosti (original)*, (2) Proizvođač, (3) Adresa, (4) Nositelj tehničke dokumentacije, (5) Proizvođač izjavljuje da stroj opisan u nastavku, (6) Ispunjava sljedeće direktive i njihovim prijenosu u nacionalno zakonodavstvo (ako je primjenjivo), (7) Za dodatke IV o strojevima, (8) Broj certifikata, (9) Ovlašteno tijelo, (10) Primjenjeni postupak, (11) Razina snage zvuka, (12) Izmjereno, (13) Zajamčeno, (14) Primjenjeni standardi o harmoniziranju, (15) Primjenjeni standardi ili tehničke priloge, (16) Urađeno u, (17) Datum, (18) Ime potpisnika, (19) Funkcija, (20) Tvrtka, (21) Potpis.

**hu :** (1) *CE megfelelőségi nyilatkozat (eredeti)*, (2) Gyártó, (3) Cím, (4) A névszaki dokumentáció birtokosa, (5) A gyártó kijelenti, hogy az alábbi termék, (6) Megfelel az alábbi irányelveknek valamint azok honosított előírásainak (ha vannak ilyenek), (7) A IV. melléklet gépéhez (adott esetben), (8) Bizonytalan szám, (9) Értékelést szervező, (10) Alkalmazott eljárás, (11) Akusztikus hang szint, (12) Mért, (13) Garantált, (14) Felhasznált harmonizált szabványok, (15) egyéb felhasznált műszaki szabványok és előírások hivatkozásai, (16) Hely, (17) Dátum, (18) Aláíró neve, (19) Funkció, (20) Vállalat, (21) Aláírás

**is :** (1) *Samræmningardóttari ESB (upprunalegt)*, (2) Framleiðandi, (3) Aðsetur, (4) Handhafi teknískrár, (5) Framleiðandi staðfestir að vélin sem lýst er hér, (6) Samræmist eftirfarandi stöðum og staðfarinu þeim með hliðsjón af þjóðarætti (ef við á), (7) Fyrir tækjabúnað í IV. viðauka, (8) Númer vottorðs, (9) Tilkynnt til, (10) Aðferð beitt, (11) Hjóðstyrkur, (12) Mældist, (13) Ábyrgð, (14) Samhæftri staðlar sem notaðir voru, (15) Aðrir staðlar eða tæknilegar forskrifir, (16) Staður, (17) Dagsetning, (18) Nafn undirritaðs, (19) Staða, (20) Fyrirtæki, (21) Underskrift.

**it :** (1) *Dichiarazione CE di conformità (originale)*, (2) Costruttore, (3) Indirizzo, (4) Titolare del fascicolo tecnico, (5) Il costruttore dichiara che la macchina descritta di seguito, (6) È conforme alle direttive seguenti e ai relativi recepimenti nella normativa nazionale (se applicabile), (7) Per le macchine Allegato IV, (8) Numero di Attestazione, (9) Organismo destinatario della notifica, (10) Procedura applicata, (11) Livello di potenza acustica, (12) Misurato, (13) Garantito, (14) Norme armonizzate applicate, (15) Norme e specifiche tecniche applicate, (16) Luogo, (17) Data, (18) Nome del firmatario, (19) Funzione, (20) Società, (21) Firma.

**lt :** (1) *EC atitikties deklaracija (originalas)*, (2) Gamintojas, (3) Adresas, (4) Techninės bylos turėtojas, (5) Gamintojas nurodo, kad mašina, aprašyta žemiau, (6) atitinka toliau nurodytas direktyvas ir į nacionalinius teisės aktus perkeltas jų nuostatas (jei taikytina), (7) IV priedas dėl mašinų, (8) Serifikata Nr., (9) Notifikuotoji įstaiga, (10) Taikyta procedūra, (11) Garso stiprumo lygis, (12) Išmatuotas, (13) Garantuojamas, (14) Naudoti dariniai standartai, (15) Kiti naudoti standartai ir techninės specifikacijos, (16) Pasirašyta, (17) Data, (18) Pasirašiusio asmens vardas ir pavardė, (19) Pareigos, (20) Bendrovė, (21) Parašas

**lv :** (1) *EK atbilstības deklarācija (oriģināla)*, (2) Ražotājs, (3) Adrese, (4) Tehniskās dokumentācijas turētājs, (5) Ražotājs apliecinā, ka turpmāk aprakstītā mašīna, (6) Atbilst tālāk norādītajām direktīvām un to iekļaušanai nacionālajā likumdošanā (ja piemērojama), (7) IV pielikuma iekārtām, (8) Serifikāta numurs, (9) Pilsvarotā iestāde, (10) Piemērotā procedūra, (11) Skaņas jaudas līmenis, (12) Izmērīts, (13) Garantēts, (14) Piemērojamas saskaņotie standarti, (15) Piemērojamas tehniskie standarti un noteikumi, (16) Sastādīts, (17) Datums, (18) Parakstītāja vārds, (19) Amats, (20) Uzņēmums, (21) Paraksts

**mt :** (1) *Dikjarazzjoni ta' Konformità ta' KE (originali)*, (2) Manifattur, (3) Indirizz, (4) Detentur tal-fajl tekniku, (5) Il-manifattur jidkijars li l-magna deskritta hawn taħt, (6) Hija konformi hija konformi mad-Direttivi segwenti u l-hijiet li jimplimentawhom fil-EU nazzjonali (jekk applikabbli), (7) Ghall-magni fl-Anness IV, (8) Numeru taċ-certifikat, (9) Entità notifkanta, (10) Proċedura applikata, (11) Livell ta' qawwa akustika, (12) Imkejjel, (13) Garantit, (14) l-standards armonizzati użati, (15) standards tekniċi u speċifikazzjonijiet oħra użati, (16) Magħmul f, (17) Data, (18) Isem il-firmatarju, (19) Kariga, (20) Kumpanija (21) Firma.

**nl :** (1) *EG-verklaring van overeenstemming (oorspronkelijk)*, (2) Fabrikant, (3) Adres, (4) Houder van het technisch dossier, (5) De fabrikant verklaart dat de hieronder beschreven machine, (6) in overeenstemming is met de volgende richtlijnen en hun omzettingen in het nationale recht (indien van toepassing), (7) Voor de machines in bijlage IV, (8) Certificatnummer, (9) Aangemelde instantie, (10) Toegestelde procedure, (11) Geluidsvermogensniveau, (12) Gemeten, (13) Gegarandeerd, (14) gehanteerde geharmoniseerde normen, (15) andere gehanteerde technische normen en specificaties, (16) Opgehaakt te, (17) Datum, (18) Naam van ondergetekende, (19) Functie, (20) Onderneming, (21) Handtekening.

**no :** (1) *CE-samsvarserklæring (original)*, (2) Produsent, (3) Adresse, (4) linehaveren av den tekniske dokumentasjonen, (5) Produsenten sier at maskinen beskrevet nedenfor, (6) Oppfyller kravene i følgende direktiver og med nasjonale gjennomføringsbestemmelser (hvis aktuelt), (7) For maskinene i bilag IV, (8) Attestnummer, (9) Teknisk kontrollorgan, (10) Anvendt prosedyra, (11) Akustisk støy, (12) Målt, (13) Garantert, (14) harmoniserede standarder som brukes, (15) Andre standarder og spesifikasjoner som brukes, (16) Utstedt, (17) Dato, (18) Underfegnede navn, (19) Stilling, (20) Firma (21) Underskrift

**pl :** (1) *Deklaracja zgodności CE (oryginał)*, (2) Producent, (3) Adres, (4) Posiadacz dokumentacji technicznej, (5) Producent oświadcza, że opisana poniżej maszyna, (6) Jest zgodna z następującymi dyrektywami i odpowiedzającymi im przepisami prawa krajowego (jeśli dotyczy), (7) Dla maszyn załącznik IV, (8) Numer certyfikatu, (9) Jednostka certyfikująca, (10) Procedura stosowana, (11) Poziom mocy akustycznej, (12) Zmierzony, (13) Gwarantowany, (14) zastosowane normy zharmonizowane, (15) Zastosowane normy lub przepisy techniczne, (16) Sporządzono w, (17) Data, (18) Nazwisko podpisującego, (19) Stanowisko, (20) Firma (21) Podpis

**pt :** (1) *Declaração de conformidade CE (original)*, (2) Fabricante, (3) Morada, (4) Titular do processo técnico, (5) O fabricante afirma que a máquina descrita abaixo, (6) Está em conformidade com as seguintes diretivas e as suas transposições para o direito nacional (se for o caso), (7) Para as máquinas no anexo IV, (8) Número de certificado, (9) Entidade notificada, (10) Procedimento aplicado, (11) Nível de potência acústica, (12) Medida, (13) Garantida, (14) normas harmonizadas utilizadas, (15) outras normas e especificações técnicas utilizadas, (16) Elaborado em, (17) Data, (18) Nome do signatário, (19) Cargo, (20) Empresa, (21) Assinatura

**ro :** (1) *Declaratie de conformitate CE (original)*, (2) Producător, (3) Adresa, (4) Titularul din dosarul tehnic, (5) Producătorul afirmă că aparatul descris mai jos, (6) Este conform cu directivele următoare și cu transpunerea lor în dreptul național (dacă este cazul), (7) Pentru mașinile din anexa IV, (8) Număr de atestare, (9) Organism notificat, (10) Procedura aplicată, (11) Nivel de putere acustică, (12) Măsurat, (13) Garantat, (14) standardele armonizate utilizate, (15) alte standarde și specificații tehnice utilizate, (16) Încotm în, (17) Data, (18) Numele persoanei care semnează, (19) Funcția, (20) Firma, (21) Semnătura

**sk :** (1) *Vyhlasenie o zhode ES (pôvodné)*, (2) Výrobca, (3) Adresa, (4) Držiteľ technickej dokumentácie, (5) Výrobca vyhlasuje, že nižšie popísaný stroj, (6) Je v súlade s nasledujúcimi smernicami a smernicami transponovanými do vnútroštátneho práva (v prípade potreby), (7) Pre stroje v príloze IV, (8) Číslo certifikátu, (9) Notifikačný orgán, (10) Použitý postup, (11) Akustická úroveň hluku, (12) Nameraná, (13) Zaručená, (14) Použitě harmonizované normy, (15) Iné použité normy a technické předpisy, (16) Miesto vydania, (17) Dátum vydania, (18) Meno podpísanej osoby, (19) Funkcia, (20) Spoločnosť, (21) Podpis

**sl :** (1) *ES izjava o skladnosti (izvirnik)*, (2) Proizvajalec, (3) Naslov, (4) Imetnik tehnične dokumentacije, (5) Proizvajalec izjavlja, da naprava, opisana v nadaljevanju, (6) Ustreza naslednjim direktivam in nacionalni zakonodaji (če ta velja), (7) Za stroje v sklopu s priložo IV, (8) Številka potrdila, (9) Priglasilni organ, (10) Uporabljeni postopki, (11) Raven akustične moči, (12) Izmerjena, (13) Zajamčena, (14) Uporabljeni usklajeni standardi, (15) Drugi uporabljeni tehnični standardi in specifikacije, (16) V, (17) Datum, (18) Ime podpisnika, (19) Funkcija, (20) Podjetje, (21) Podpis.

**sv :** (1) *EG-förklaring om överensstämmelse (original)*, (2) Tillverkare, (3) Adress, (4) Ägaren av det tekniska underlaget, (5) Tillverkaren försäkras att den maskin som beskrivs nedan, (6) Överensstämmer med nedanstående direktiv och införlivandet av dem i nationellt rätt (om tillämpligt), (7) För maskinerna i bilaga IV, (8) Nummer för godkännande, (9) Anmält organ, (10) Förfarande som tillämpats, (11) Ljudtrycksnivå, (12) Uppmätt, (13) Garanterad (14) Harmoniserade standarder som använts, (15) andra tekniska standarder och specifikationer som använts, (16) Upprättat i, (17) Datum, (18) Namn på den som undertecknat, (19) Befattning, (20) Företag (21) Namnteckning

1) **DÉCLARATION "CE" DE CONFORMITÉ (originale)**  
**"EC" DECLARATION OF CONFORMITY (original)**

2) Constructeur, *Manufacturer* : **MANITOU BF**

3) Adresse, *Address* : **430, RUE DE LAUBINIÈRE - B.P 10249  
44158 - ANCENIS - CEDEX - FRANCE**

4) Titulaire de dossier technique, *Holder of the technical file* : **MANITOU BF**

3) Adresse, *Address* : **430, RUE DE LAUBINIÈRE - B.P 10249  
44158 - ANCENIS - CEDEX - FRANCE**

5) Le constructeur déclare que la machine décrite ci-après, *The manufacturer declares that the machine described below* :

<b>MLT 630 105D V ST4 S2</b>	<b>52000947/00000</b>	<b>N° &gt;MAN00000E00000000&lt;.PME</b>
<b>MLT 630 105D V CP ST4 S2</b>	<b>52000946/00000</b>	<b>N° &gt;MAN00000E00000000&lt;.PME</b>
<b>MLT 730 105D V ST4 S1</b>	<b>52000970/00000</b>	<b>N° &gt;MAN00000E00000000&lt;.PME</b>
<b>MLT 730 105D V CP ST4 S1</b>	<b>52000969/00000</b>	<b>N° &gt;MAN00000E00000000&lt;.PME</b>

6) Est conforme aux directives suivantes et à leurs transpositions en droit national (si applicables), *Complies with the following directives and their transpositions into national law (if applicable)* :

**2006/42/CE**

7) Pour les machines annexe IV, *For annex IV machines* :

8) Numéro d'attestation, *Certificate number* :

9) Organisme notifié, *Notified body* : -

**2000/14/CE + 2005/88/CE**

10) Procédure appliquée, *Applied procedure* :

9) Organisme notifié, *Notified body* :

11) Niveau de puissance acoustique, *Sound power level* :

12) Mesuré, *Measured* : dB (A)

13) Garanti, *Guaranteed* : dB (A)

**2004/108/CE jusqu'au 19/04/2016 et 2014/30/UE à partir du 20/04/2016**

14) Normes harmonisées utilisées, *Harmonised standards used* :

15) Normes ou dispositions techniques utilisées, *Standards or technical provisions used* :

16) Fait à, *Done at* :

17) Date, *Date* :

18) Nom du signataire, *Name of signatory* :

19) Fonction, *Function* :

20) Société, *Company* :

21) Signature, *Signature* :

**bg :** (1) *ЕОД декларация за съответствие (оригинал)*, (2) Производител, (3) Адрес, (4) Притежател на техническото досие, (5) Производителят декларира, че описаната по-долу машина, (6) Е в съответствие със следните директиви и тяхното транспониране в националното законодателство (ако е приложимо), (7) Приложение IV относно машините, (8) Номер на сертификата, (9) Нотифициран орган, (10) Приложена процедура, (11) Ниво на силата на звука, (12) Измерено, (13) Гарантирано, (14) Използвани хармонизирани стандарти, (15) Използвани стандарти или технически разпоредби, (16) Изработено в, (17) Дата, (18) Име на подписаното лице, (19) Длъжност, (20) Фирма, (21) Подпис

**cs :** (1) *ES prohlášení o shodě (původní)*, (2) Výrobce, (3) Adresa, (4) Držitel technické dokumentace, (5) Výrobce prohlašuje, že zařízení popsané níže, (6) Je v souladu s následujícími směrnici a s směrnici transponovanými do vnitrostátního práva (je-li relevantní), (7) Pro stroje v příloze IV(8) Číslo certifikátu, (9) Notifikační orgán, (10) Použitý postup, (11) Úroveň hluku (12) Naměřená, (13) Zaručená, (14) Použitá harmonizované normy, (15) Použitá normy nebo technické předpisy(16) Místo (17) Datum (18) Jméno podepsaného, (19) Funkce, (20) Společnost, (21) Podpis

**da :** (1) *EF Overensstemmelseserklæring (original)*, (2) Producent, (3) Adresse, (4) Indehaver af det tekniske dossier, (5) Producenten erklærer, at maskinen, der er beskrevet nedenfor, (6) overholder nedenstående direktiver og disse gennemførelse til national ret (hvis det er relevant), (7) For maskiner under bilag IV, (8) Certificatnummer, (9) Bemyndigede organ, (10) Anvendt procedure, (11) Lydeffektniveau, (12) Målt, (13) Garanteret, (14) Anvendte harmoniserede standarder, (15) Standarder eller tekniske regler, (16) Udfærdiget i, (17) Dato, (18) Underskrivers navn, (19) Funktion, (20) Firma, (21) Underskrift.

**de :** (1) *EG-Konformitätserklärung (original)*, (2) Hersteller, (3) Adresse, (4) Inhaber des technischen Dokuments, (5) Der Hersteller erklärt, dass die nachstehend beschriebene Maschine (6) den folgenden Richtlinien und deren Umsetzung in die nationale Gesetzgebung entspricht (falls anwendbar), (7) Für die Maschinen laut Anhang IV, (8) Bescheinigungsnummer, (9) Benannte Stelle, (10) Angewandtes Verfahren, (11) Schalleistungspegel, (12) Gemessen, (13) Gewährleistet, (14) angewandte harmonisierte Normen, (15) angewandte sonstige technische Normen und Bestimmungen, (16) Ausgestellt in, (17) Datum, (18) Name des Unterzeichners, (19) Funktion, (20) Gesellschaft, (21) Unterschrift.

**el :** (1) *Δήλωση συμμόρφωσης CE (πρωτότυπο)*, (2) Κατασκευαστής, (3) Διεύθυνση, (4) Κάτοχος του τεχνικού φακέλου, (5) Ο κατασκευαστής δηλώνει ότι το μηχάνημα που περιγράφεται παρακάτω, (6) Συμμορφώνεται με τις εθνικές οδηγίες και τις προσαρμογές τους στο εθνικό δίκαιο (κατά περίπτωση), (7) Για τα μηχανήματα του παραρτήματος IV, (8) Αριθμός πιστοποίησης, (9) Διοικητικό φορέας, (10) Εφαρμοζόμενη διαδικασία, (11) Στάθμη ηχητικής ισχύος, (12) Καταμετρημένο, (13) Εγγυημένο, (14) Εναρμονισμένα πρότυπα που χρησιμοποιούνται, (15) Πρότυπο ή τεχνικοί κανόνες που χρησιμοποιούνται, (16) Τόπος, (17) Ημερομηνία, (18) Όνομα του υπογράφοντος, (19) Ιδιότητα, (20) Εταιρεία, (21) Υπογραφή

**es :** (1) *Declaración CE de conformidad (original)*, (2) Fabricante, (3) Dirección, (4) Titular del expediente técnico, (5) El fabricante declara que la máquina que se describe a continuación, (6) Cumple con las siguientes directivas y sus transposiciones a la legislación nacional (en caso oportuno), (7) Para las máquinas anexo IV, (8) Número de certificación, (9) Organismo notificado, (10) Procedimiento aplicado, (11) Nivel de potencia acústica, (12) Medido, (13) Garantizado, (14) Normas armonizadas utilizadas, (15) Otras normas o especificaciones técnicas utilizadas, (16) Hecho en, (17) Fecha, (18) Nombre del signatario, (19) Cargo, (20) Empresa, (21) Firma.

**et :** (1) *EÜ vastavusdeklaratsioon (algupärane)*, (2) Tootja, (3) Aadress, (4) Tehnilise dokumentatsiooni vastaja, (5) Tootja kinnitab, et allpool kirjeldatud seade, (6) On vastavuses järgmistele direktiivide ja nende reguleerimisse õigusse ülevõtmiseks vastuvõetud õigusaktidega (kui on kohaldatav), (7) IV lisas loetletud seadmete puhul, (8) Tunnistuse number, (9) Serifitseerimisasutus, (10) Kohaldatav menetlus, (11) Akustilise võimsuse tase, (12) Mõeldud, (13) Tagatud, (14) Vastab kehtivalele ühistule standarditele, (15) Vastab muudele kehtivatele standarditele ja tehnilistele normidele, (16) Väljaandmise koht, (17) Väljaandmise aeg, (18) Allkirjastaja nimi, (19) Amet, (20) Ettevõtte, (21) Allkiri

**fi :** (1) *EY-vaatimustenmukaisuusvakuutus (alkuperäinen)*, (2) Valmistaja, (3) Osasto, (4) Teknisten asiakirjojen haltaja, (5) Valmistaja ilmoittaa, että alla kuvattu laite, (6) Täyttää seuraavien direktiivien sekä niitä vastaavien kansallisten säännösten vaatimukset (tarvittaessa), (7) Liitteen IV laitteiden osalta, (8) Todistusnumero, (9) Ilmoituslaitos, (10) Käytetyt menetelytavat, (11) Äänen tehotaso, (12) Mittattu, (13) Taattu, (14) Käytetyt yhdenmukaistetut standardit, (15) Käytetyt tekniset standardit tai säännökset, (16) Paikka, (17) Aika, (18) Allekirjoittajan nimi, (19) Toimi, (20) Yritys, (21) Allekirjoitus.

**ga :** (1) *Dearbháil comhréireachta « CE » (tuasach)*, (2) Déantóir, (3) Seoladh, (4) Sealbóir an chomhaid theicniúil, (5) Dearbhalonn an déantóir go ndéanann an t-inneal ar a bhíll cur síos thíos, (6) Cloíonn sé le na treochra seo a leanas agus lena d'fhasar isteach i ndáil náisiúnta (más cuí), (7) Le haghaidh innill an agúisín IV, (8) Uimhir teastais, (9) Comhábhaí a d'ugair fógra dó, (10) Níos ísleachta a cuireadh i bhfeidhm, (11) Leibhéal cumhachta na fuaimne, (12) Tomhasa, (13) Ráthaithe, (14) Caighdeán chomhchruibhítha a úsáideadh, (15) Caighdeán nó fóirleacha teicniúla a úsáideadh, (16) Ama dhéanamh ag, (17) Dáta, (18) Ainm an tsíntheora, (19) Feidhmeannas, (20) Comhábhaí (21) Síniú.

**hr :** (1) *EK deklaracija o usklađenosti (original)*, (2) Proizvođač, (3) Adresa, (4) Nositelj tehničke dokumentacije, (5) Proizvođač izjavljuje da stroj opisan u nastavku, (6) Ispunjava sljedeće direktive i njihovim prijenosu u nacionalno zakonodavstvo (ako je primjenjivo), (7) Za dodatke IV o strojevima, (8) Broj certifikata, (9) Ovlašteno tijelo, (10) Primjenjeni postupak, (11) Razina snage zvuka, (12) Izmjereno, (13) Zajamčeno, (14) Primjenjeni standardi o harmoniziranju, (15) Primjenjeni standardi ili tehničke priloge, (16) Urađeno u, (17) Datum, (18) Ime potpisnika, (19) Funkcija, (20) Tvrtka, (21) Potpis.

**hu :** (1) *CE megfelelőségi nyilatkozat (eredeti)*, (2) Gyártó, (3) Cím, (4) A részaki dokumentáció birtokosa, (5) A gyártó kijelenti, hogy az alábbi termék, (6) Megfelel az alábbi irányelveknek valamint azok honosított előírásainak (ha vannak ilyenek), (7) A IV. melléklet gépéhez (adott esetben), (8) Bizonytalan szám, (9) Értékelő szervezet, (10) Alkalmazott eljárás, (11) Akusztikus hang szint, (12) Mért, (13) Garantált, (14) Felhasznált harmonizált szabványok, (15) egyéb felhasznált műszaki szabványok és előírások hivatkozásai, (16) Hely, (17) Dátum, (18) Aláíró neve, (19) Funkció, (20) Vállalat, (21) Aláírás

**is :** (1) *Samræmiðgarðvörðun ESB (upprunaleg)*, (2) Framleiðandi, (3) Aðsetur, (4) Handhafi teknískrár, (5) Framleiðandi staðfestir að vélin sem lýst er hér, (6) Samræmist eftirfarandi stöðum og staðfarinu þeim með hidsöfn af þjóðarætti (ef við á), (7) Fyrir tækjabúnað í IV. viðauka, (8) Númer vottorðs, (9) Tilkynnt til, (10) Aðferð beitt, (11) Hjóðstyrkur, (12) Mældist, (13) Ábyrgð, (14) Samhærni staðlar sem notaðir voru, (15) Aðrir staðlar eða tæknilegar forskrifir, (16) Staður, (17) Dagssetning, (18) Nafn undirritaðs, (19) Staða, (20) Fyrirtæki, (21) Underskrift.

**it :** (1) *Dichiarazione CE di conformità (originale)*, (2) Costruttore, (3) Indirizzo, (4) Titolare del fascicolo tecnico, (5) Il costruttore dichiara che la macchina descritta di seguito, (6) È conforme alle direttive seguenti e ai relativi recepimenti nella normativa nazionale (se applicabile), (7) Per le macchine Allegato IV, (8) Numero di Attestazione, (9) Organismo destinatario della notifica, (10) Procedura applicata, (11) Livello di potenza acustica, (12) Misurato, (13) Garantito, (14) Norme armonizzate applicate, (15) Norme e specifiche tecniche applicate, (16) Luogo, (17) Data, (18) Nome del firmatario, (19) Funzione, (20) Società, (21) Firma.

**lt :** (1) *EC atitikties deklaracija (originalas)*, (2) Gamintojas, (3) Adresas, (4) Techninės bylos turėtojas, (5) Gamintojas nurodo, kad mašina, aprašyta žemiau, (6) atitinka toliau nurodytas direktyvas ir j nacionalinius teisės aktus perkeltas į nuostatas (jei taikytina), (7) IV priedas dėl mašinų, (8) Serifikato Nr., (9) Notifikuotoji įstaiga, (10) Taikyta procedūra, (11) Garso stiprumo lygis, (12) Išmatuotas, (13) Garantuojamas, (14) Naudojami dariniai standartai, (15) Kiti naudojami standartai ir techninės specifikacijos, (16) Pasirašyta, (17) Data, (18) Pasirašiusio asmens vardas ir pavardė, (19) Pareigos, (20) Bendrovė, (21) Parašas

**lv :** (1) *EK atbilstības deklarācija (oriģināla)*, (2) Ražotājs, (3) Adrese, (4) Tehniskās dokumentācijas turētājs, (5) Ražotājs apliecinā, ka turpmāk aprašītais mašīna, (6) Atbilst tālāk norādītajām direktīvām un to iekļaušanai nacionālajā likumdošanā (ja piemērojama), (7) IV pielikuma iekārtām, (8) Serifikāta numurs, (9) Pildvarotā iestāde, (10) Piemērotā procedūra, (11) Skaņas jaudas līmenis, (12) Izmērīts, (13) Garantēts, (14) Piemērojamas saskaņotie standarti, (15) Piemērojamas tehniskie standarti un noteikumi, (16) Sastādīts, (17) Datums, (18) Parakstītāja vārds, (19) Amats, (20) Uzņēmums, (21) Paraksts

**mt :** (1) *Dikjarazzjoni ta' Konformità ta' KE (originali)*, (2) Manifattur, (3) Indirizz, (4) Detentur tal-fajl tekniku, (5) Il-manifattur jidkijars li l-magna deskritta hawn taħt, (6) Hija konformi hija konformi mad-Direttivi segwenti u l-hijiet li jimplimentawhom fil-EU nazzjonali (jekk applikabbli), (7) Ghall-magni fl-Anness IV, (8) Numru taċ-ċertifikat, (9) Entità notifikata, (10) Procedura applikata, (11) Livell ta' qawwa akustika, (12) Imkejjel, (13) Garantit, (14) l-standards armonizzati użati, (15) standards tekniċi u speċifikazzjonijiet oħra użati, (16) Magħmul f, (17) Data, (18) Isem il-firmatarju, (19) Kariga, (20) Kumpanja (21) Firma.

**nl :** (1) *EG-verklaring van overeenstemming (oorspronkelijk)*, (2) Fabrikant, (3) Adres, (4) Houder van het technisch dossier, (5) De fabrikant verklaart dat de hieronder beschreven machine, (6) in overeenstemming is met de volgende richtlijnen en hun omzettingen in het nationale recht (indien van toepassing), (7) Voor de machines in bijlage IV, (8) Certificatnummer, (9) Aangemelde instantie, (10) Toegepaste procedure, (11) Geluidsvermogensniveau, (12) Gemeten, (13) Gegarandeerd, (14) gehanteerde geharmoniseerde normen, (15) andere gehanteerde technische normen en specificaties, (16) Opge maakt in, (17) Datum, (18) Naam van ondergetekende, (19) Functie, (20) Onderneming, (21) Handtekening.

**no :** (1) *CE-samsvarserklæring (original)*, (2) Produsent, (3) Adresse, (4) linehaveren av den tekniske dokumentasjonen, (5) Produsenten sier at maskinen beskrevet nedenfor, (6) Oppfyller kravene i følgende direktiver og med nasjonale gjennomføringsbestemmelser (hvis aktuelt), (7) For maskinene i bilag IV, (8) Attestnummer, (9) Teknisk kontrollorgan, (10) Anvendt prosedyre, (11) Akustisk støy, (12) Målt, (13) Garantert, (14) harmoniserede standarder som brukes, (15) Andre standarder og spesifikasjoner som brukes, (16) Utstedt, (17) Dato, (18) Undertegnedes navn, (19) Stilling, (20) Firma (21) Underskrift

**pl :** (1) *Deklaracja zgodności CE (oryginał)*, (2) Producent, (3) Adres, (4) Posiadacz dokumentacji technicznej, (5) Producent oświadcza, że opisana poniżej maszyna, (6) Jest zgodna z następującymi dyrektywami i odpowiedziami im przepisami prawa krajowego (jeśli dotyczy), (7) Dla maszyn załącznik IV, (8) Numer certyfikatu, (9) Jednoetka certyfikująca, (10) Procedura stosowana, (11) Poziom mocy akustycznej, (12) Zmierzony, (13) Gwarantowany, (14) zastosowane normy zharmonizowane, (15) Zastosowane normy lub przepisy techniczne, (16) Sporządzono w, (17) Data, (18) Nazwisko podpisującego, (19) Stanowisko, (20) Firma (21) Podpis

**pt :** (1) *Declaração de conformidade CE (original)*, (2) Fabricante, (3) Morada, (4) Titular do processo técnico, (5) O fabricante afirma que a máquina descrita abaixo, (6) Está em conformidade com as seguintes diretivas e as suas transposições para o direito nacional (se for o caso), (7) Para as máquinas no anexo IV, (8) Número de certificado, (9) Entidade notificada, (10) Procedimento aplicado, (11) Nível de potência acústica, (12) Medida, (13) Garantida, (14) normas harmonizadas utilizadas, (15) outras normas e especificações técnicas utilizadas, (16) Elaborado em, (17) Data, (18) Nome do signatário, (19) Cargo, (20) Empresa, (21) Assinatura

**ro :** (1) *Declarație de conformitate CE (original)*, (2) Producător, (3) Adresă, (4) Titularul din dosarul tehnic, (5) Producătorul afirmă că aparatul descris mai jos, (6) Este conform cu directivele următoare și cu transpunerea lor în dreptul național (dacă este cazul), (7) Pentru mașinile din anexa IV, (8) Număr de atestare, (9) Organism notificat, (10) Procedură aplicată, (11) Nivel de putere acustică, (12) Măsurat, (13) Garantat, (14) standardele armonizate utilizate, (15) alte standarde și specificații tehnice utilizate, (16) Încotm în, (17) Data, (18) Numele persoanei care semnează, (19) Funcția, (20) Firma, (21) Semnătura

**sk :** (1) *Vyhlasenie o zhode ES (pôvodné)*, (2) Výrobca, (3) Adresa, (4) Držiteľ technickej dokumentácie, (5) Výrobca vyhlasuje, že nižšie popísaný stroj, (6) Je v súlade s nasledujúcimi smernicami a s smernicami transponovanými do vnútroštátneho práva (v prípade potreby), (7) Pre stroje v príloze IV, (8) Číslo certifikátu, (9) Notifikačný orgán, (10) Použitý postup, (11) Akustická úroveň hluku, (12) Nameraná, (13) Zaručená, (14) Použitá harmonizované normy, (15) Iné použité normy a technické predpisy, (16) Miesto vydania, (17) Dátum vydania, (18) Meno podpísanej osoby, (19) Funkcia, (20) Spoločnosť, (21) Podpis

**sl :** (1) *ES izjava o skladnosti (izvirnik)*, (2) Proizvajalec, (3) Naslov, (4) Imetnik tehnične dokumentacije, (5) Proizvajalec izjavlja, da naprava, opisana v nadaljevanju, (6) Ustreza naslednjim direktivam in nacionalni zakonodaji (če ta velja), (7) Za stroje v sklopu s prilogo IV, (8) Številka potrdila, (9) Priglaseno organ, (10) Uporabljeni postopek, (11) Raven akustične moči, (12) Izmerjena, (13) Zajamčena, (14) Uporabljeni usklajeni standardi, (15) Drugi uporabljeni tehnični standardi in specifikacije, (16) V, (17) Datum, (18) Ime podpisnika, (19) Funkcija, (20) Podjetje, (21) Podpis.

**sv :** (1) *EG-förklaring om överensstämmelse (original)*, (2) Tillverkare, (3) Adress, (4) Ägaren av det tekniska underlaget, (5) Tillverkaren försäkrar att den maskin som beskrivs nedan, (6) Överensstämmer med nedanstående direktiv och införlivandet av dem i nationellt rätt (om tillämpligt), (7) För maskinerna i bilaga IV, (8) Nummer för godkännande, (9) Anmält organ, (10) Förfarande som tillämpats, (11) Ljudtrycksnivå, (12) Uppmätt, (13) Garanterad (14) Harmoniserade standarder som använts, (15) andra tekniska standarder och specifikationer som använts, (16) Upprättat i, (17) Datum, (18) Namn på den som undertecknat, (19) Befattning, (20) Företag (21) Namnteckning

## SAFETY PLATES AND STICKERS

### ⚠ IMPORTANT ⚠

Clean all stickers and safety plates so that they are legible.  
Any safety plates and stickers which are illegible or damaged must be replaced.  
Check that stickers and safety plates are present after replacing any spare parts.

### EXTERNAL PLATES AND STICKERS

REF.	PART NO.	DESCRIPTION
1	24653	- Slings point
2	52563320	- Tie-down point
3	289013	- Towing instruction
4	234798	- Hydraulic oil
5	296998	- Maniscopic safety instruction
6	234805	- Hydraulic coupling instruction
7	305405	- Diesel fuel
8	52576441	- Battery cut-off instruction
9	52518055	- Battery troubleshooting
10	207525	- Hydraulic towing hook (OPTION)
11	310025	- Hydraulic towing hook visibility (OPTION)
12	52551658	- Air conditioning (OPTION)
13	289625	- Easy attachment connection (OPTION)
14	256513	- Boom electrical predisposition (OPTION)
15	676079	- Towing hook crushing hazard (OPTION)
16	288174	- Accumulator instructions
17	52567646	- Emergency output

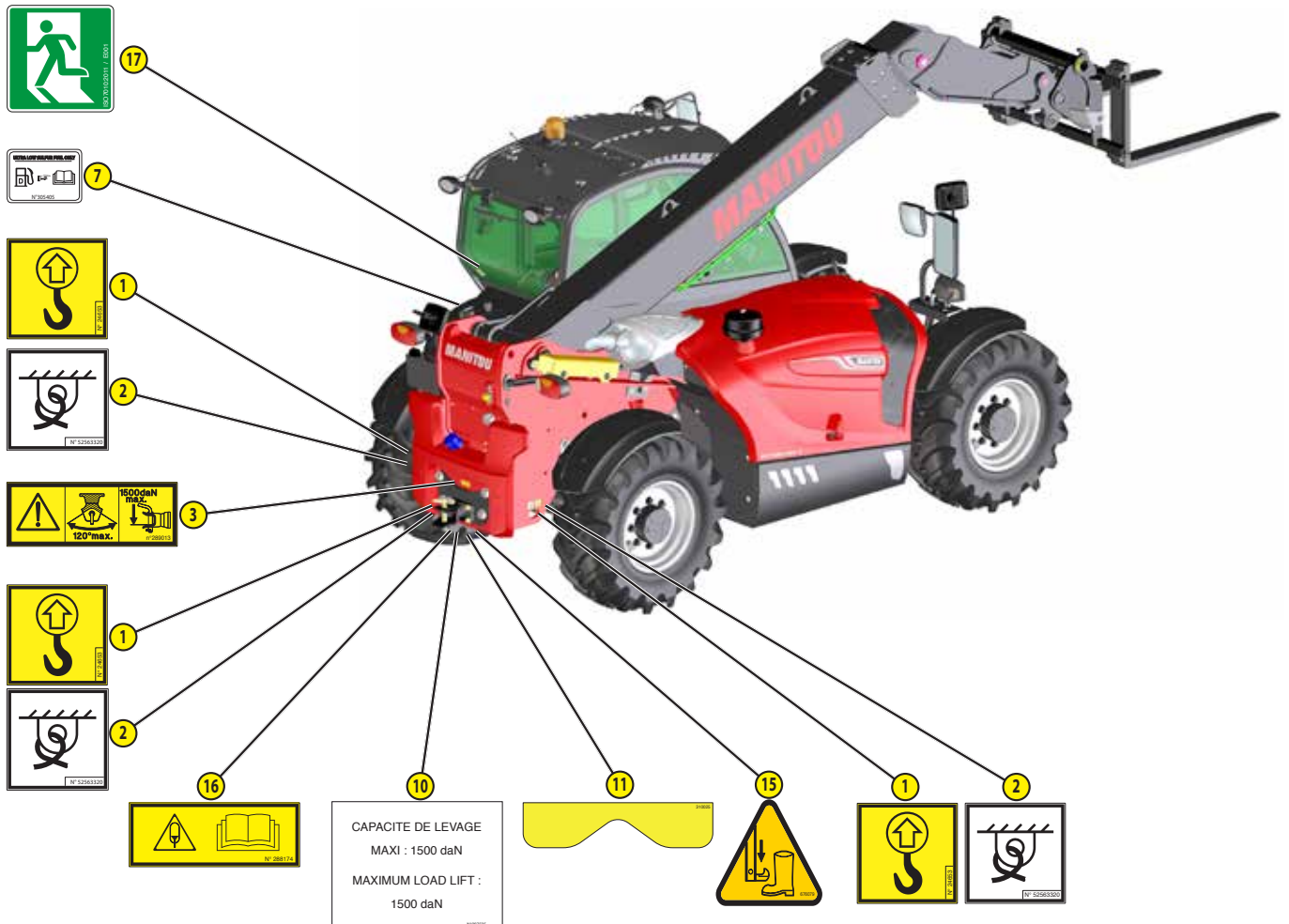

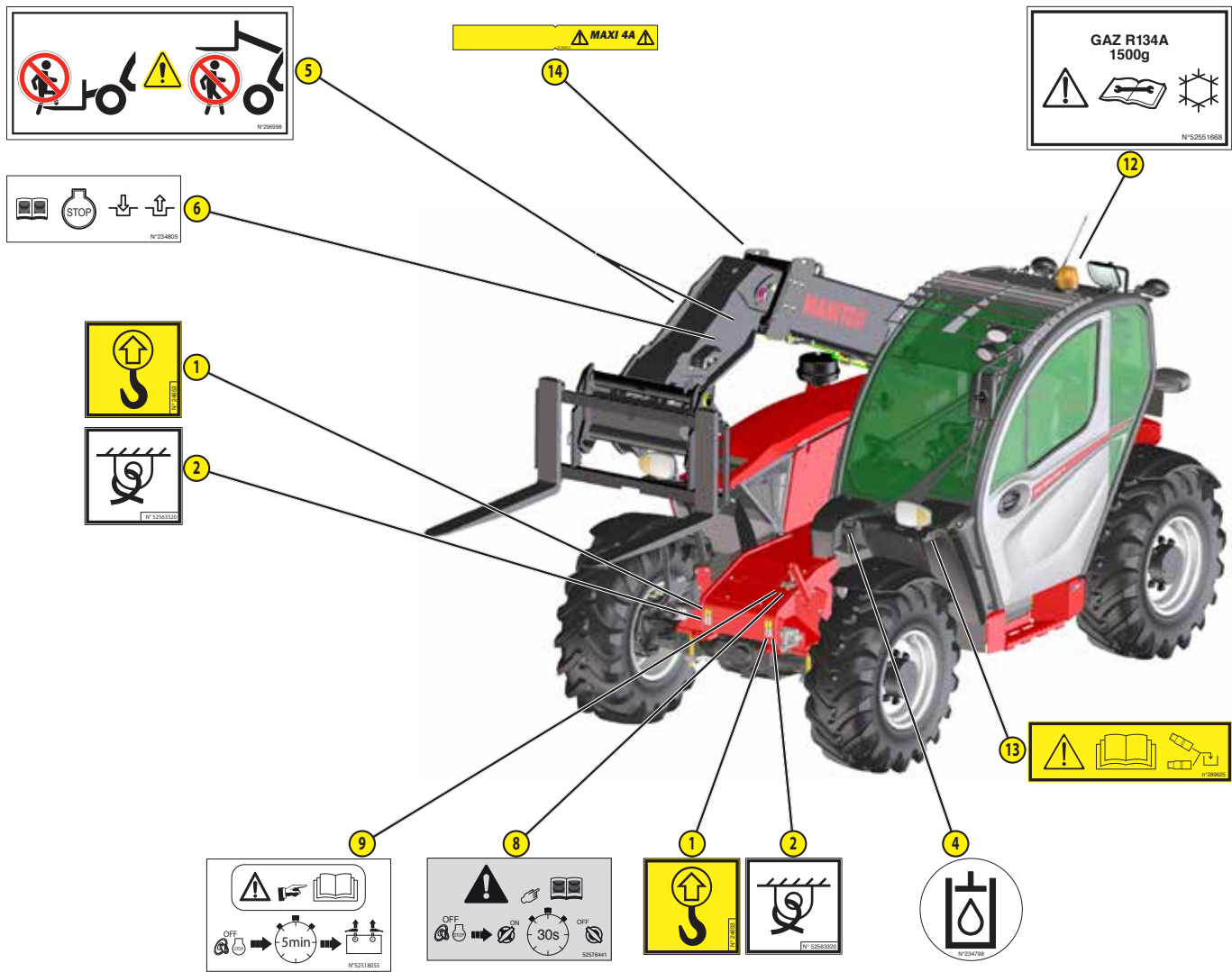

**STICKERS AND PLATES UNDER THE ENGINE HOOD**

REF.	PART NO.	DESCRIPTION
1	52515083	- Anti-freeze
2	259398	- Water/diesel separator
3	52556683	- Engine fuse
4	233088	- Preheat rod (OPTION)

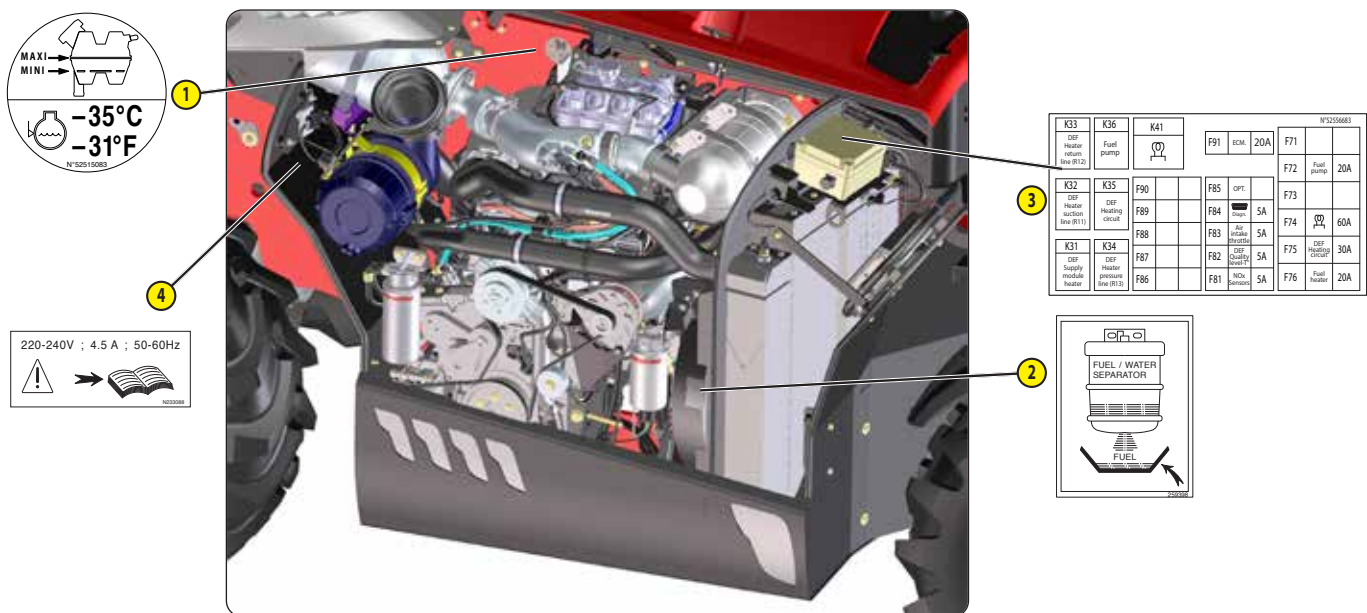

K33	K36	K41	F91	K64	20A	F71	
DEF Heater return (New R112)	Fuel pump					F72	Fuel pump 20A
K32	K35	F90	F85	OPT.		F73	
DEF Heater (action) (New R112)	DEF Heating circuit	F89	F84	SA	SA	F74	60A
		F88	F83	SA		F75	DEF Heating circuit 30A
K31	K34	F87	F82	SA		F76	DEF Heating circuit 20A
DEF Supply (middle) Heater	DEF Heater (optional) (New R112)	F86	F81	SA			

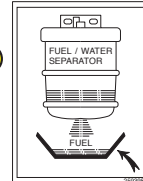

**PLATES AND STICKERS IN THE CAB**

REF.	PART NO.	DESCRIPTION
1	52553498	- Cab compliance
2	223324	- Patents
3	204079	- Hydraulic towing hook (OPTION)
5	52553496	- Cab homologation
6	239596	- Sound power level 106dB
7	52545467	- Steering selection control
8	290183	- Bucket instruction on telescope
9	52553499	- Operating mode management instruction
10	52582323	- Fuses (MLT 630 ...)
10	52565553	- Fuses (MLT 730 ...)
11	52544967	- Pictogram switches
12	52553497	- Reach chart sheet
13	241621	- Safety instruction
15	255968	- Joystick function (MLT 630 ...)
15	52509000	- Joystick function (MLT 730 ...)
16	52574665	- Consumption sheet (MLT 630 ...)
16	52605387	- Consumption sheet (MLT 730 ...)
17	52579106	- Cab category 1
18	52651762	- Hydraulic controls activation (DEPENDING ON ASSEMBLY)

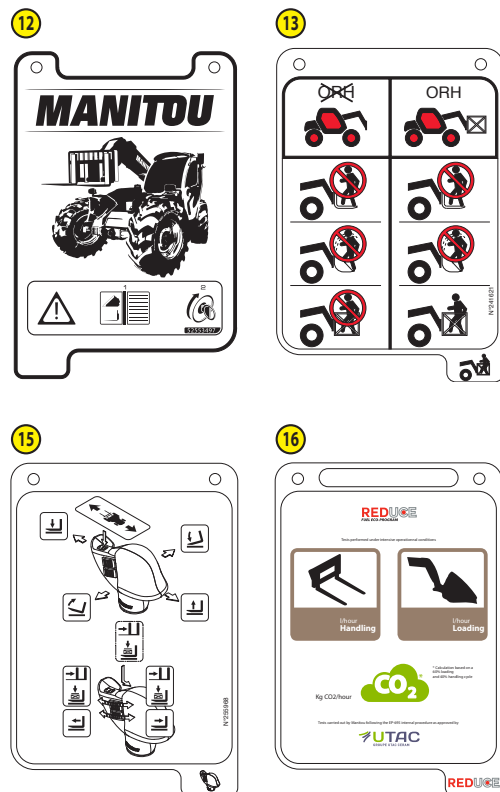

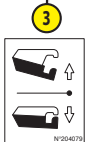
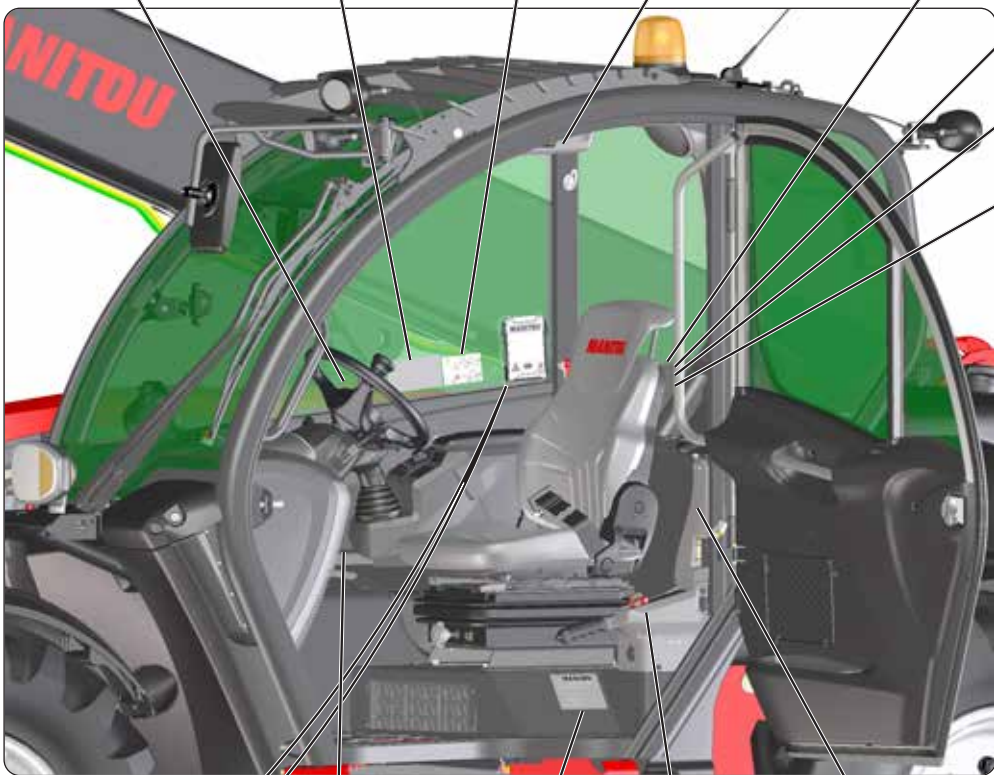
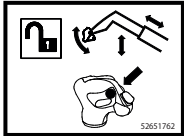
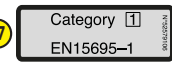
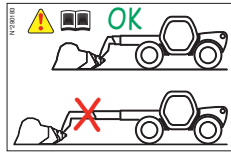
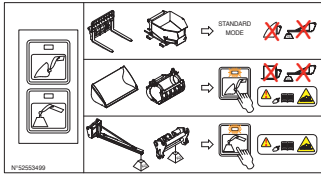

1  
 CABINE CONFORME A :  
 CAB CONFORMS TO :  
 ○ FOPS-ISO 3449  
 ○ ROPS-ISO 3471  
 ○ ANSI B 56.6  
 N°52553498

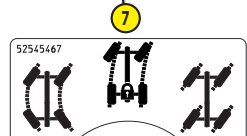

## IDENTIFICATION OF THE LIFT TRUCK

As our policy is to promote a constant improvement in our products, our range of lift trucks may undergo certain modifications, without any obligation for us to advise our customers.

When you order parts, or when you require any technical information, always specify the following information.

NOTE: For the owner's convenience, it is recommended that a note of these numbers is made in the spaces provided, at the time of the delivery of the lift truck.

For any further technical information regarding your lift truck refer to: CHARACTERISTICS.

### LIFT TRUCK MANUFACTURER'S PLATE

"Designation" Designation	
"Series" Series	
"Year of manufacture" Year of manufacture	
"Model year" Model year	
"Serial Number / Product Identification Number" Serial number/Product identification number	
"Unladen mass" Unladen weight	
"Power" Power	
"Authorized gross vehicle weight" Authorised gross vehicle weight	
"Rated capacity" Rated capacity	
"Max vertical force (on trailer hook)" Maximum vertical force (on towing hook)	
"Drag strain" Pulling force	



### TRACTOR TYPE APPROVAL PLATE

"Category" Category	
"Homologation N°" Homologation number	
"Product Identification Number" Product identification number	
"Total permissible mass" Total permissible weight	
"Maximum mass on front axle" Maximum mass on front axle	
"Maximum mass on rear axle" Maximum mass on rear axle	
"PERMISSIBLE TOWABLE MASS" PERMISSIBLE TOWABLE WEIGHT	
• "B-1 unbraked" unbraked	
• "B-2 inertia braked" inertia braked	
• "B-3 hydraulic braked" hydraulic braked	
• "B-4 pneumatic braked" pneumatic braked	
• "T-1 drawbar" drawbar	
• "T-2 rigid drawbar" rigid drawbar	
• "T-3 centre axle" centre axle	



### ENGINE

"MODEL" Model	
"CODE" Code	
"E1" Identification	
"SERNO" Serial number	
"SPEC" Specification	



**TRANSFER BOX**

Type	
Serial number	
MANITOU Part No.	



**HYDROSTATIC PUMP**

"CNR" MANITOU Part No.	
"TYP" Codification	
"MNR" Manufacturing number	
"SN" Serial number	
"FD" Date of manufacture	



**HYDROSTATIC MOTOR**

"CNR" MANITOU Part No.	
"TYP" Codification	
"MNR" Manufacturing number	
"SN" Serial number	
"FD" Date of manufacture	



**FRONT AXLE**

Type	
Serial number	
MANITOU Part No.	



**REAR AXLE**

Type	
Serial number	
MANITOU Part No.	

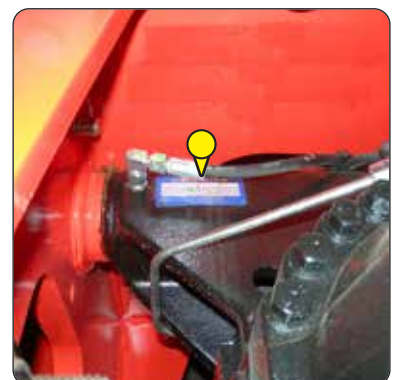

### CAB

"Constructeur" Manufacturer	
"Type Cabine" Cabin type	
"Numéro de série" Serial number	



### BOOM

MANITOU Part No.	
Date of manufacture and manufacturer	

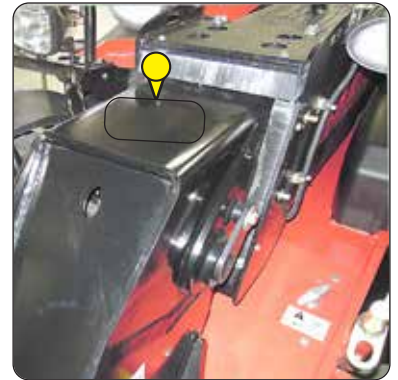

### FRAME

Serial number/Product identification number	
---	--



### ATTACHMENT MANUFACTURER'S PLATE

"MODELE" Model	
"N° série" Serial number	
"Année Fabrication" Year of manufacture	
"Masse à vide" Unladen weight	
"Centre de gravité" Centre of gravity	
"Capacité Nominale" Rated capacity	
"Pression service" Working pressure	





<b>ENGINE</b>		
Type		DEUTZ TCD3.6L4F / CFX174A
Fuel		Diesel
Number of cylinders		4 in line
Suction		Supercharged
Injection system		Direct
Ignition sequence		1.3.4.2
Capacity	cm <sup>3</sup>	3621
Bore and stroke	mm	98 x 120
Compression ratio		17.2
Nominal speed laden	rpm	2200
Min. rpm unladen	rpm	930
Max. rpm unladen	rpm	2360
Power ISO/TR 14396	hp - kW	101 - 74.4
Power SAE J 1995	hp - kW	101 - 74.4
Maximum torque ISO/TR 14396	N.m	410 at 1600 rpm
Air filtration efficiency	%	99.9
Type of cooling		Water
Fan		Puller

<b>TRANSMISSION</b>		
Hydrostatic pump		BOSCH REXROTH
- Type		A4VG71 Variable displacement piston pump
- Forward/reverse selector		Electro-hydraulic
- Number of forward speeds		2 (1 slow and 1 fast)
- Number of reverse speeds		2 (1 slow and 1 fast)
Main pump		
- MAX - MIN. displacement	cm <sup>3</sup> /r	0 - 71
- MAX. flow rate	l/min	156
- Working pressure	bar	450
Booster pump		
- Capacity	cm <sup>3</sup> /r	19.6
- MAX. flow rate	l/min	43
- Boost pressure MAX. speed	Bar	20
Hydrostatic motor		
- Type		A6VM115EP100PN00A/71MWV0P4Z91FV-0 Two-way variable motor
- MAX - MIN. displacement	cm <sup>3</sup> /r	0 - 115.6
Reduction gearbox		DANA
Front axle		DANA
- Differential		Limited slip
Rear axle		DANA
- Differential		Without locking
Drive wheels		Permanent 4 WD
- 2/4 wheel drive control		No
		<b>20" TYRES</b>
Front tyres		ALLIANCE
- Size		400/70 R20 149A8 A580
- Pressure	bar	3.5
		<b>24" TYRES</b>
Rear tyres		ALLIANCE
- Size		400/70 R20 149A8 A580
- Pressure	bar	3.5

<b>ELECTRIC CIRCUIT</b>		
Battery	STANDARD OPTION	12V - 180 Ah - 900 A EN
Alternator		14V - 120 A
- Type		ISKRA AAK3869
Starter		12V - 4 kW
- Type		ISKRA AZF4302

<b>BRAKE SYSTEM</b>	
Service brake	Hydraulic power brake
- Type of brake	Oil-immersed multi-disc brake
- Type of control	By foot on front axle
Parking brake	Mechanical
- Type of brake	Oil-immersed multi-disc brake
- Type of control	Manual

<b>HYDRAULIC CIRCUIT</b>			
Hydraulic pump		Gears	
- Type		1st casing	2nd body
- Capacity	cm <sup>3</sup>	44	24.8
- Max. rating capacity unladen	l/min	104	59
- Flow rate at 1600 rpm	l/min	70	40
Filtration			
- Return	µm	10	10
- Suction	µm	135	135
Maximum service pressure		250	
- Telescoping circuit	bar	250 - 195	
- Lifting circuit	bar	250 - 250	
- Tilting circuit	bar	250 - 195	
- Attachment circuit	bar	250	
- Steering circuit	bar	180	

<b>HYDRAULIC MOVEMENTS</b>		
Longitudinal stability limiter and warning device		Electronic
Lifting motions (boom retracted)		
- Unladen lifting	s - m/min	6.5 - 38.3
- Laden lifting	s - m/min	9.2 - 27.1
- Unladen lowering	s - m/min	5 - 49.8
- Laden lowering	s - m/min	4.6 - 54.1
Telescoping motions (boom raised)		
- Unladen extending	s - m/min	5.4 - 22.5
- Laden extending	s - m/min	5.6 - 23.3
- Unladen retracting	s - m/min	3 - 42
- Laden retracting	s - m/min	3 - 42
Tilting movements		
- Unladen digging	s - °/s	3.4 - 42.9
- Unladen discharging	s - °/s	2.7 - 54.1

<b>SOUND AND VIBRATION</b>		
Sound pressure level in the driver's cab LpA (according to standard EN 12053)	dB(A)	74 (cab closed); xx (cab open)
Sound pressure (according to Directive 2009/76)	dB(A)	xx (cab closed); xx (cab open)
Sound pressure level ensured in the LwA environment (according to Directive 2000/14/EC modified by Directive 2005/88/EC)	dB(A)	xxx (measured); 105 (guaranteed)
Average weighted acceleration on driver's body (according to standard EN 13059)	m/s <sup>2</sup>	1.13
Sound level in motion (according to Directive 2009/63)	dB(A)	xx
The average weighted acceleration transmitted to the driver's hand/ arm system (according to standard ISO 5349-2)	m/s <sup>2</sup>	< 2.5
Standard seat vibration	m/s <sup>2</sup>	xx (lightweight operator); xx (heavyweight operator)

<b>SPECIFICATIONS AND WEIGHTS</b>				
			<b>20" TYRES</b>	<b>24" TYRES</b>
Speed of movement for lift truck in standard configuration on flat ground				
- Front unladen	1 Slow	km/h	18	18
	1 Fast	km/h	38	40
- Rear unladen	1 Slow	km/h	18	18
	1 Fast	km/h	38	40
Standard attachment			PFB 35 MT1260	PFB 35 MT1260
- Weight of attachment (without forks)		kg	95	95
- Weight of forks (each)		kg	72.5	72.5
Rated capacity with standard attachment			3000	3000
Tipping load at maximum reach on tires			1250	1300
Distance from the centre of gravity of the load to the base of the forks			500	500
Standard lifting height			6000	6100
Lift truck weight without attachment			6520	6680
Weight of lift truck with standard attachment				
- Unladen		kg	6760	6920
- At rated load		kg	9760	9920
Weight per axle with standard attachment (transport position)				
- Front unladen		kg	3200	3280
- Rear unladen		kg	3560	3640
- Front rated load		kg	8410	8490
- Rear rated load		kg	1350	1430
Weight per axle with standard attachment (boom extended)				
- Front rated load		kg	7270	7350
- Rear rated load		kg	740	820
Drag strain on the coupling hook				
- Unladen (sliding)		daN	5000	5000
- At rated load (transmission setting)		daN	6540	6540
Break-out force with bucket (according to standard ISO 8313)			5840	5840



<b>ENGINE</b>		
Type		DEUTZ TCD3.6L4F / CFX174A
Fuel		Diesel
Number of cylinders		4 in line
Suction		Supercharged
Injection system		Direct
Ignition sequence		1.3.4.2
Capacity	cm <sup>3</sup>	3621
Bore and stroke	mm	98 x 120
Compression ratio		17.2
Nominal speed laden	rpm	2200
Min. rpm unladen	rpm	930
Max. rpm unladen	rpm	2360
Power ISO/TR 14396	hp - kW	101 - 74.4
Power SAE J 1995	hp - kW	101 - 74.4
Maximum torque ISO/TR 14396	N.m	410 at 1600 rpm
Air filtration efficiency	%	99.9
Type of cooling		Water
Fan		Puller

<b>TRANSMISSION</b>		
Hydrostatic pump		BOSCH REXROTH
- Type		A4VG71 Variable displacement piston pump
- Forward/reverse selector		Electro-hydraulic
- Number of forward speeds		2 (1 slow and 1 fast)
- Number of reverse speeds		2 (1 slow and 1 fast)
Main pump		
- MAX - MIN. displacement	cm <sup>3</sup> /r	0 - 71
- MAX. flow rate	l/min	156
- Working pressure	bar	450
Booster pump		
- Capacity	cm <sup>3</sup> /r	19.6
- MAX. flow rate	l/min	43
- Boost pressure MAX. speed	Bar	20
Hydrostatic motor		
- Type		A6VM115EP100PN00A/71MWV0P4Z91FV-0 Two-way variable motor
- MAX - MIN. displacement	cm <sup>3</sup> /r	0 - 115.6
Reduction gearbox		DANA
Front axle		DANA
- Differential		Limited slip
Rear axle		DANA
- Differential		Without locking
Drive wheels		Permanent 4 WD
- 2/4 wheel drive control		No
Front tyres		ALLIANCE
- Size		400/70 R20 149A8 A580
- Pressure	bar	3.5
Rear tyres		ALLIANCE
- Size		400/70 R20 149A8 A580
- Pressure	bar	3.5

<b>ELECTRIC CIRCUIT</b>		
Battery	STANDARD OPTION	12V - 180 Ah - 900 A EN
Alternator		14V - 120 A
- Type		ISKRA AAK3869
Starter		12V - 4 kW
- Type		ISKRA AZF4302

<b>BRAKE SYSTEM</b>	
Service brake	Hydraulic power brake
- Type of brake	Oil-immersed multi-disc brake
- Type of control	By foot on front axle
Parking brake	Mechanical
- Type of brake	Oil-immersed multi-disc brake
- Type of control	Manual

<b>HYDRAULIC CIRCUIT</b>			
Hydraulic pump		Gears	
- Type		1st casing	2nd body
- Capacity	cm <sup>3</sup>	44	24.8
- Max. rating capacity unladen	l/min	104	59
- Flow rate at 1600 rpm	l/min	70	40
Filtration			
- Return	µm	10	10
- Suction	µm	135	135
Maximum service pressure		250	
- Telescoping circuit	bar	250 - 195	
- Lifting circuit	bar	250 - 250	
- Tilting circuit	bar	250 - 195	
- Attachment circuit	bar	250	
- Steering circuit	bar	180	

<b>HYDRAULIC MOVEMENTS</b>		
Longitudinal stability limiter and warning device		Electronic
Lifting motions (boom retracted)		
- Unladen lifting	s - m/min	6.5 - 38.3
- Laden lifting	s - m/min	9.2 - 27.1
- Unladen lowering	s - m/min	5 - 49.8
- Laden lowering	s - m/min	4.6 - 54.1
Telescoping motions (boom raised)		
- Unladen extending	s - m/min	5.4 - 22.5
- Laden extending	s - m/min	5.6 - 23.3
- Unladen retracting	s - m/min	3 - 42
- Laden retracting	s - m/min	3 - 42
Tilting movements		
- Unladen digging	s - °/s	3.4 - 42.9
- Unladen discharging	s - °/s	2.7 - 54.1

<b>SOUND AND VIBRATION</b>		
Sound pressure level in the driver's cab LpA (according to standard EN 12053)	dB(A)	74 (cab closed); xx (cab open)
Sound pressure (according to Directive 2009/76)	dB(A)	xx (cab closed); xx (cab open)
Sound pressure level ensured in the LwA environment (according to Directive 2000/14/EC modified by Directive 2005/88/EC)	dB(A)	xxx (measured); 105 (guaranteed)
Average weighted acceleration on driver's body (according to standard EN 13059)	m/s <sup>2</sup>	1.13
Sound level in motion (according to Directive 2009/63)	dB(A)	xx
The average weighted acceleration transmitted to the driver's hand/ arm system (according to standard ISO 5349-2)	m/s <sup>2</sup>	< 2.5
Standard seat vibration	m/s <sup>2</sup>	xx (lightweight operator); xx (heavyweight operator)

## SPECIFICATIONS AND WEIGHTS

Speed of movement for lift truck in standard configuration on flat ground			
- Front unladen	1 Slow	km/h	18
	1 Fast	km/h	38
- Rear unladen	1 Slow	km/h	18
	1 Fast	km/h	38
Standard attachment			PFB 35 MT1260
- Weight of attachment (without forks)		kg	95
- Weight of forks (each)		kg	72.5
Rated capacity with standard attachment			3000
Tipping load at maximum reach on tires			1250
Distance from the centre of gravity of the load to the base of the forks			500 mm
Standard lifting height			6000 mm
Lift truck weight without attachment			6520 kg
Weight of lift truck with standard attachment			
- Unladen		kg	6760
- At rated load		kg	9760
Weight per axle with standard attachment (transport position)			
- Front unladen		kg	3200
- Rear unladen		kg	3560
- Front rated load		kg	8410
- Rear rated load		kg	1350
Weight per axle with standard attachment (boom extended)			
- Front rated load		kg	7270
- Rear rated load		kg	740
Drag strain on the coupling hook			
- Unladen (sliding)		daN	5000
- At rated load (transmission setting)		daN	6540
Break-out force with bucket (according to standard ISO 8313)			5840 daN



<b>ENGINE</b>		
Type		DEUTZ TCD3.6L4F / CFX185A
Fuel		Diesel
Number of cylinders		4 in line
Suction		Supercharged
Injection system		Direct
Ignition sequence		1.3.4.2
Capacity	cm <sup>3</sup>	3621
Bore and stroke	mm	98 x 120
Compression ratio		17.2
Nominal speed laden	rpm	2200
Min. rpm unladen	rpm	930
Max. rpm unladen	rpm	2300
Power ISO/TR 14396	hp - kW	116 - 85
Power SAE J 1995	hp - kW	116 - 85
Maximum torque ISO/TR 14396	N.m	460 at 1600 rpm
Air filtration efficiency	%	99.9
Type of cooling		Water
Fan		Puller

<b>TRANSMISSION</b>		
Hydrostatic pump		BOSCH REXROTH
- Type		A4VG71 Variable displacement piston pump
- Forward/reverse selector		Electro-hydraulic
- Number of forward speeds		2 (1 slow and 1 fast)
- Number of reverse speeds		2 (1 slow and 1 fast)
Main pump		
- MAX - MIN. displacement	cm <sup>3</sup> /r	0 - 71
- MAX. flow rate	l/min	156
- Working pressure	bar	450
Booster pump		
- Capacity	cm <sup>3</sup> /r	19.6
- MAX. flow rate	l/min	43
- Boost pressure MAX. speed	Bar	20
Hydrostatic motor		
- Type		A6VM115EP100PN00A/71MWV0P4Z91FV-0 Two-way variable motor
- MAX - MIN. displacement	cm <sup>3</sup> /r	0 - 115.6
Reduction gearbox		DANA
Front axle		DANA
- Differential		Limited slip
Rear axle		DANA
- Differential		Without locking
Drive wheels		Permanent 4 WD
- 2/4 wheel drive control		No
		<b>20" TYRES</b>
Front tyres		ALLIANCE
- Size		400/70 R20 149A8 A580
- Pressure	bar	3.5
		<b>24" TYRES</b>
Rear tyres		ALLIANCE
- Size		400/70 R20 149A8 A580
- Pressure	bar	3.5

<b>ELECTRIC CIRCUIT</b>		
Battery	STANDARD OPTION	12V - 180 Ah - 900 A EN
Alternator		14V - 120 A
- Type		ISKRA AAK3869
Starter		12V - 4 kW
- Type		ISKRA AZF4302

<b>BRAKE SYSTEM</b>	
Service brake	Hydraulic power brake
- Type of brake	Oil-immersed multi-disc brake
- Type of control	By foot on front axle
Parking brake	Mechanical
- Type of brake	Oil-immersed multi-disc brake
- Type of control	Manual

<b>HYDRAULIC CIRCUIT</b>			
Hydraulic pump		Gears	
- Type		1st casing	2nd body
- Capacity	cm <sup>3</sup>	44	24.8
- Max. rating capacity unladen	l/min	101	57
- Flow rate at 1600 rpm	l/min	70	40
Filtration			
- Return	µm	10	10
- Suction	µm	135	135
Maximum service pressure		250	
- Telescoping circuit	bar	250 - 195	
- Lifting circuit	bar	250 - 250	
- Tilting circuit	bar	250 - 195	
- Attachment circuit	bar	250	
- Steering circuit	bar	180	

<b>HYDRAULIC MOVEMENTS</b>		
Longitudinal stability limiter and warning device		Electronic
Lifting motions (boom retracted)		
- Unladen lifting	s - m/min	7.4 - 35.8
- Laden lifting	s - m/min	10.5 - 25.2
- Unladen lowering	s - m/min	5.7 - 46.4
- Laden lowering	s - m/min	5.2 - 50.9
Telescoping motions (boom raised)		
- Unladen extending	s - m/min	6.2 - 24.9
- Laden extending	s - m/min	6.5 - 26.1
- Unladen retracting	s - m/min	3.4 - 47.6
- Laden retracting	s - m/min	3.4 - 47.6
Tilting movements		
- Unladen digging	s - °/s	3.4 - 42.9
- Unladen discharging	s - °/s	2.7 - 54.1

<b>SOUND AND VIBRATION</b>		
Sound pressure level in the driver's cab LpA (according to standard EN 12053)	dB(A)	74 (cab closed); xx (cab open)
Sound pressure (according to Directive 2009/76)	dB(A)	xx (cab closed); xx (cab open)
Sound pressure level ensured in the LwA environment (according to Directive 2000/14/EC modified by Directive 2005/88/EC)	dB(A)	xxx (measured); 105 (guaranteed)
Average weighted acceleration on driver's body (according to standard EN 13059)	m/s <sup>2</sup>	1.13
Sound level in motion (according to Directive 2009/63)	dB(A)	xx
The average weighted acceleration transmitted to the driver's hand/ arm system (according to standard ISO 5349-2)	m/s <sup>2</sup>	< 2.5
Standard seat vibration	m/s <sup>2</sup>	xx (lightweight operator); xx (heavyweight operator)

<b>SPECIFICATIONS AND WEIGHTS</b>				
			<b>20" TYRES</b>	<b>24" TYRES</b>
Speed of movement for lift truck in standard configuration on flat ground				
- Front unladen	1 Slow	km/h	18	18
	1 Fast	km/h	38	40
- Rear unladen	1 Slow	km/h	18	18
	1 Fast	km/h	38	40
Standard attachment			PFB 35 MT1260	PFB 35 MT1260
- Weight of attachment (without forks)		kg	95	95
- Weight of forks (each)		kg	72.5	72.5
Rated capacity with standard attachment		kg	3000	3000
Tipping load at maximum reach on tires		kg	900	900
Distance from the centre of gravity of the load to the base of the forks		mm	500	500
Standard lifting height		mm	6850	6950
Lift truck weight without attachment		kg	6720	6880
Weight of lift truck with standard attachment				
- Unladen		kg	6960	7120
- At rated load		kg	9960	10120
Weight per axle with standard attachment (transport position)				
- Front unladen		kg	3560	3640
- Rear unladen		kg	3400	3480
- Front rated load		kg	9060	9140
- Rear rated load		kg	900	980
Weight per axle with standard attachment (boom extended)				
- Front rated load		kg	7240	7320
- Rear rated load		kg	620	700
Drag strain on the coupling hook				
- Unladen (sliding)		daN	5000	5000
- At rated load (transmission setting)		daN	6540	6540
Break-out force with bucket (according to standard ISO 8313)		daN	5840	5840



<b>ENGINE</b>		
Type		DEUTZ TCD3.6L4F / CFX185A
Fuel		Diesel
Number of cylinders		4 in line
Suction		Supercharged
Injection system		Direct
Ignition sequence		1.3.4.2
Capacity	cm <sup>3</sup>	3621
Bore and stroke	mm	98 x 120
Compression ratio		17.2
Nominal speed laden	rpm	2200
Min. rpm unladen	rpm	930
Max. rpm unladen	rpm	2300
Power ISO/TR 14396	hp - kW	116 - 85
Power SAE J 1995	hp - kW	116 - 85
Maximum torque ISO/TR 14396	N.m	460 at 1600 rpm
Air filtration efficiency	%	99.9
Type of cooling		Water
Fan		Puller

<b>TRANSMISSION</b>		
Hydrostatic pump		BOSCH REXROTH
- Type		A4VG71
- Forward/reverse selector		Variable displacement piston pump
- Number of forward speeds		Electro-hydraulic
- Number of reverse speeds		2 (1 slow and 1 fast)
Main pump		2 (1 slow and 1 fast)
- MAX - MIN. displacement	cm <sup>3</sup> /r	0 - 71
- MAX. flow rate	l/min	156
- Working pressure	bar	450
Booster pump		
- Capacity	cm <sup>3</sup> /r	19.6
- MAX. flow rate	l/min	43
- Boost pressure MAX. speed	Bar	20
Hydrostatic motor		
- Type		A6VM115EP100PN00A/71MWV0P4Z91FV-0
- MAX - MIN. displacement	cm <sup>3</sup> /r	Two-way variable motor
Reduction gearbox		0 - 115.6
Front axle		DANA
- Differential		DANA
Rear axle		Limited slip
- Differential		DANA
Drive wheels		Without locking
- 2/4 wheel drive control		Permanent 4 WD
Front tyres		No
- Size		ALLIANCE
- Pressure	bar	400/70 R20 149A8 A580
Rear tyres		3.5
- Size		ALLIANCE
- Pressure	bar	400/70 R20 149A8 A580
		3.5

<b>ELECTRIC CIRCUIT</b>		
Battery	STANDARD OPTION	12V - 180 Ah - 900 A EN
Alternator		14V - 120 A
- Type		ISKRA AAK3869
Starter		12V - 4 kW
- Type		ISKRA AZF4302

<b>BRAKE SYSTEM</b>	
Service brake	Hydraulic power brake
- Type of brake	Oil-immersed multi-disc brake
- Type of control	By foot on front axle
Parking brake	Mechanical
- Type of brake	Oil-immersed multi-disc brake
- Type of control	Manual

<b>HYDRAULIC CIRCUIT</b>			
Hydraulic pump		Gears	
- Type		1st casing	2nd body
- Capacity	cm <sup>3</sup>	44	24.8
- Max. rating capacity unladen	l/min	101	57
- Flow rate at 1600 rpm	l/min	70	40
Filtration			
- Return	µm	10	10
- Suction	µm	135	135
Maximum service pressure		250	
- Telescoping circuit	bar	250 - 195	
- Lifting circuit	bar	250 - 250	
- Tilting circuit	bar	250 - 195	
- Attachment circuit	bar	250	
- Steering circuit	bar	180	

<b>HYDRAULIC MOVEMENTS</b>		
Longitudinal stability limiter and warning device		Electronic
Lifting motions (boom retracted)		
- Unladen lifting	s - m/min	7.4 - 35.8
- Laden lifting	s - m/min	10.5 - 25.2
- Unladen lowering	s - m/min	5.7 - 46.4
- Laden lowering	s - m/min	5.2 - 50.9
Telescoping motions (boom raised)		
- Unladen extending	s - m/min	6.2 - 24.9
- Laden extending	s - m/min	6.5 - 26.1
- Unladen retracting	s - m/min	3.4 - 47.6
- Laden retracting	s - m/min	3.4 - 47.6
Tilting movements		
- Unladen digging	s - °/s	3.4 - 42.9
- Unladen discharging	s - °/s	2.7 - 54.1

<b>SOUND AND VIBRATION</b>		
Sound pressure level in the driver's cab LpA (according to standard EN 12053)	dB(A)	74 (cab closed); xx (cab open)
Sound pressure (according to Directive 2009/76)	dB(A)	xx (cab closed); xx (cab open)
Sound pressure level ensured in the LwA environment (according to Directive 2000/14/EC modified by Directive 2005/88/EC)	dB(A)	xxx (measured); 105 (guaranteed)
Average weighted acceleration on driver's body (according to standard EN 13059)	m/s <sup>2</sup>	1.13
Sound level in motion (according to Directive 2009/63)	dB(A)	xx
The average weighted acceleration transmitted to the driver's hand/ arm system (according to standard ISO 5349-2)	m/s <sup>2</sup>	< 2.5
Standard seat vibration	m/s <sup>2</sup>	xx (lightweight operator); xx (heavyweight operator)

## SPECIFICATIONS AND WEIGHTS

Speed of movement for lift truck in standard configuration on flat ground			
- Front unladen	1 Slow	km/h	18
	1 Fast	km/h	38
- Rear unladen	1 Slow	km/h	18
	1 Fast	km/h	38
Standard attachment			PFB 35 MT1260
- Weight of attachment (without forks)		kg	95
- Weight of forks (each)		kg	72.5
Rated capacity with standard attachment			3000
Tipping load at maximum reach on tires			900
Distance from the centre of gravity of the load to the base of the forks			500 mm
Standard lifting height			6850 mm
Lift truck weight without attachment			6720 kg
Weight of lift truck with standard attachment			
- Unladen		kg	6960
- At rated load		kg	9960
Weight per axle with standard attachment (transport position)			
- Front unladen		kg	3560
- Rear unladen		kg	3400
- Front rated load		kg	9060
- Rear rated load		kg	900
Weight per axle with standard attachment (boom extended)			
- Front rated load		kg	7240
- Rear rated load		kg	620
Drag strain on the coupling hook			
- Unladen (sliding)		daN	5000
- At rated load (transmission setting)		daN	6540
Break-out force with bucket (according to standard ISO 8313)			5840 daN



MLT 630 105DV ST4 S2		PRESSURE (bar)	LOAD PER TYRE (kg)			
			FRONT UNLADEN	FRONT LADEN	REAR UNLADEN	REAR LADEN
ALLIANCE	400/70 R20 149A8 A580	3.5	1600	4200	1800	700
	460/70 R24 159A8 A580	3.5	1650	4250	1800	700
	405/70 R24 150A8	3.5	1650	4250	1800	700
MICHELIN	400/70 R20 XMCL 149A8	3.5	1600	4200	1800	700
	400/70R20 149A8 BIBLOAD	3.5	1600	4200	1800	700
	460/70 R24 XMCL 159A8	3.5	1650	4250	1800	700
	460/70 R24 159A8 BIBLOAD	3.5	1650	4250	1800	700
NOKIAN	460/65R24 TRI STEEL	3.5	1650	4250	1800	700
TRELLEBORG	460/70R24 159A8 TH400	3.5	1650	4250	1800	700
VREDESTEIN	460/70R24 ENDURION	3.2	1650	4250	1800	700

MLT 630 105DV CP ST4 S2		PRESSURE (bar)	LOAD PER TYRE (kg)			
			FRONT UNLADEN	FRONT LADEN	REAR UNLADEN	REAR LADEN
ALLIANCE	400/70 R20 149A8 A580	3.5	1600	4200	1800	700
	500/45 R20 160A8 A331	3.5	1600	4200	1800	700
MICHELIN	400/70 R20 XMCL 149A8	3.5	1600	4200	1800	700
	400/70R20 149A8 BIBLOAD	3.5	1600	4200	1800	700

		PRESSURE (bar)	LOAD (kg)	GROUND CONTACT PRESSURE (kg/cm <sup>2</sup> )		GROUND CONTACT AREA (cm <sup>2</sup> )	
				HARD GROUND	SOFT GROUND	HARD GROUND	SOFT GROUND
ALLIANCE	400/70 R20 149A8 A580	3.5	700				
			1600				
			1650				
			1800				
			4200				
			4250				
	460/70 R24 159A8 A580	3.5	700				
			1600				
			1650				
			1800				
			4200				
			4250				
	405/70 R24 150A8	3.5	700				
			1600				
			1650				
			1800				
4200							
4250							
500/45 R20 160A8 A331	3.5	700					
		1600					
		1800					
		4200					
MICHELIN	400/70 R20 XMCL 149A8	3.5	700				
			1600				
			1650				
			1800				
			4200				
			4250				
	400/70R20 149A8 BIBLOAD	3.5	700				
			1600				
			1650				
			1800				
			4200				
			4250				
	460/70 R24 XMCL 159A8	3.5	700				
			1600				
			1650				
			1800				
4200							
4250							
460/70 R24 159A8 BIBLOAD	3.5	700					
		1600					
		1650					
		1800					
		4200					
		4250					
NOKIAN	460/65R24 TRI STEEL	3.5	700				
			1600				
			1650				
			1800				
			4200				
			4250				
TRELLEBORG	460/70R24 159A8 TH400	3.5	700				
			1600				
			1650				
			1800				
			4200				
			4250				
VREDESTEIN	460/70R24 ENDURION	3.2	700				
			1650				
			1800				
			4250				

MLT 730 115DV ST4 S1		PRESSURE (bar)	LOAD PER TYRE (kg)			
			FRONT UNLADEN	FRONT LADEN	REAR UNLADEN	REAR LADEN
ALLIANCE	400/70 R20 149A8 A580	3.5	1800	4550	1700	450
	460/70 R24 159A8 A580	3.5	1800	4550	1750	500
	405/70 R24 150A8	3.5	1800	4550	1750	500
MICHELIN	400/70 R20 XMCL 149A8	3.5	1800	4550	1700	450
	400/70R20 149A8 BIBLOAD	3.5	1800	4550	1700	450
	460/70 R24 XMCL 159A8	3.5	1800	4550	1750	500
	460/70 R24 159A8 BIBLOAD	3.5	1800	4550	1750	500
NOKIAN	460/65R24 TRI STEEL	3.5	1800	4550	1750	500
TRELLEBORG	460/70R24 159A8 TH400	3.5	1800	4550	1750	500
VREDESTEIN	460/70R24 ENDURION	3.2	1800	4550	1750	500

MLT 730 115DV CP ST4 S1		PRESSURE (bar)	LOAD PER TYRE (kg)			
			FRONT UNLADEN	FRONT LADEN	REAR UNLADEN	REAR LADEN
ALLIANCE	400/70 R20 149A8 A580	3.5	1800	4550	1700	450
	500/45 R20 160A8 A331	3.5	1800	4550	1700	450
MICHELIN	400/70 R20 XMCL 149A8	3.5	1800	4550	1700	450
	400/70R20 149A8 BIBLOAD	3.5	1800	4550	1700	450

		PRESSURE (bar)	LOAD (kg)	GROUND CONTACT PRESSURE (kg/cm <sup>2</sup> )		GROUND CONTACT AREA (cm <sup>2</sup> )	
				HARD GROUND	SOFT GROUND	HARD GROUND	SOFT GROUND
ALLIANCE	400/70 R20 149A8 A580	3.5	450				
			500				
			1700				
			1750				
			1800				
	460/70 R24 159A8 A580	3.5	450				
			500				
			1700				
			1750				
			1800				
	405/70 R24 150A8	3.5	450				
			500				
			1700				
			1750				
			1800				
	500/45 R20 160A8 A331	3.5	450				
1700							
1800							
4550							
MICHELIN	400/70 R20 XMCL 149A8	3.5	450				
			500				
			1700				
			1750				
			1800				
	400/70R20 149A8 BIBLOAD	3.5	450				
			500				
			1700				
			1750				
	460/70 R24 XMCL 159A8	3.5	450				
			500				
			1700				
			1750				
			1800				
	460/70 R24 159A8 BIBLOAD	3.5	450				
			500				
1700							
1750							
1800							
NOKIAN	460/65R24 TRI STEEL	3.5	450				
			500				
			1700				
			1750				
			1800				
TRELLEBORG	460/70R24 159A8 TH400	3.5	450				
			500				
			1700				
			1750				
			1800				
VREDESTEIN	460/70R24 ENDURION	3.2	500				
			1750				
			1800				
			4550				

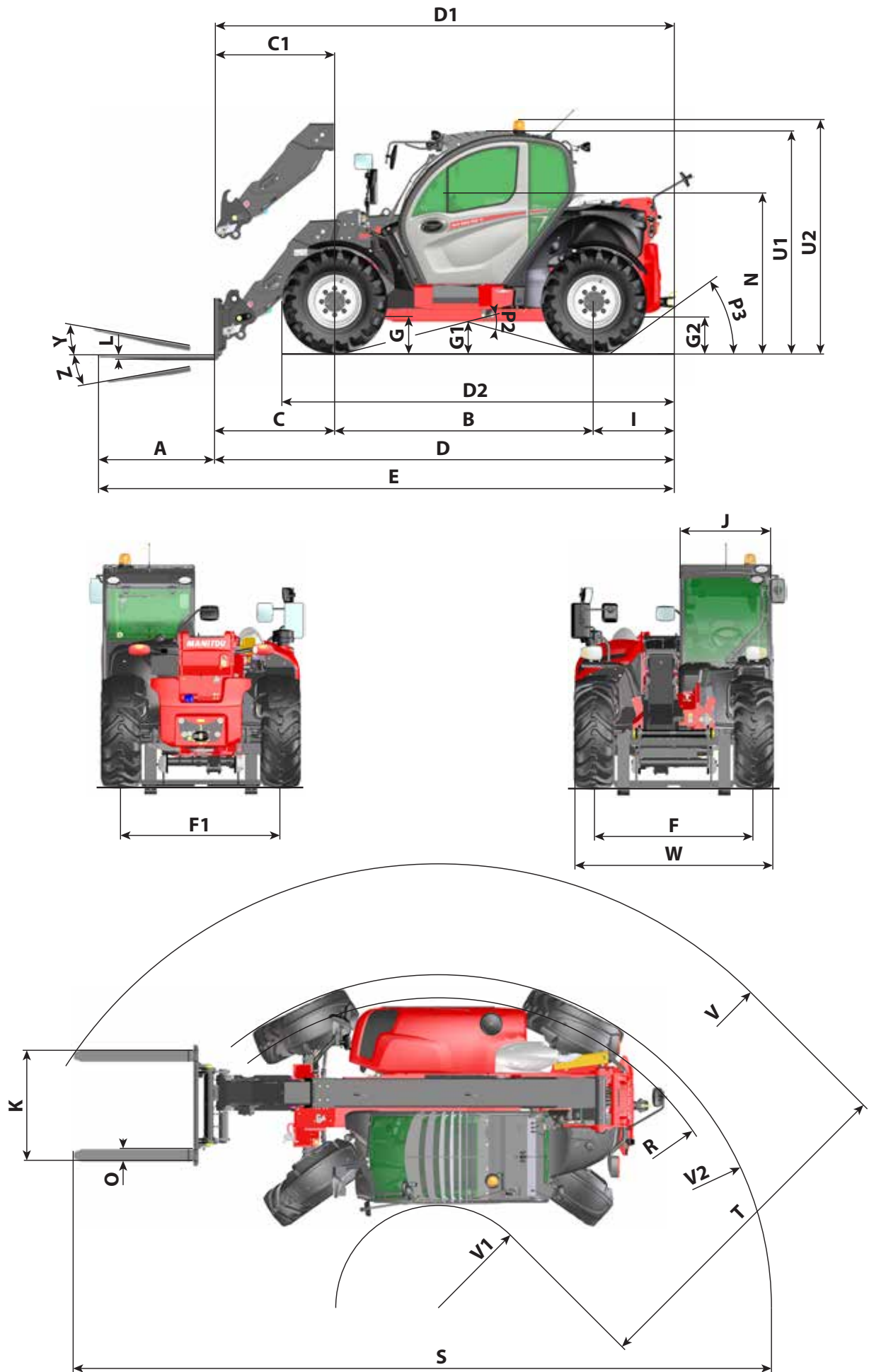

		20" TYRES 400/70 R20	24" TYRES 405/70 R24	24" TYRES 460/70 R24
A	mm	1200	1200	1200
B	mm	2690	2690	2690
C	mm	1251	1251	1251
C1	mm	1203	1203	1203
D	mm	4784	4784	4784
D1	mm	4736	4736	4736
D2	mm	4069	4121	4158
E	mm	5984	5984	5984
F	mm	1650	1730	1690
F1	mm	1650	1730	1690
G	mm	352	457	457
G1	mm	283	388	388
G2	mm	352	457	457
I	mm	843	843	843
J	mm	950	950	950
K	mm	1260	1260	1260
L	mm	45	45	45
N	mm	1621	1726	1726
O	mm	125	125	125
P2	°	47	37	37
P3	°	35	42	42
R	mm	3440	3480	3460
S	mm	7441	7481	7487
T	mm	3615	3615	3615
U1	mm	2263	2368	2368
U2	mm	2375	2480	2480
V	mm	4955	4955	4955
V1	mm	1340	1340	1340
V2	mm	3645	3681	3691
W	mm	2060	2132	2152
Y	°	13	13	13
Z	°	133	133	133

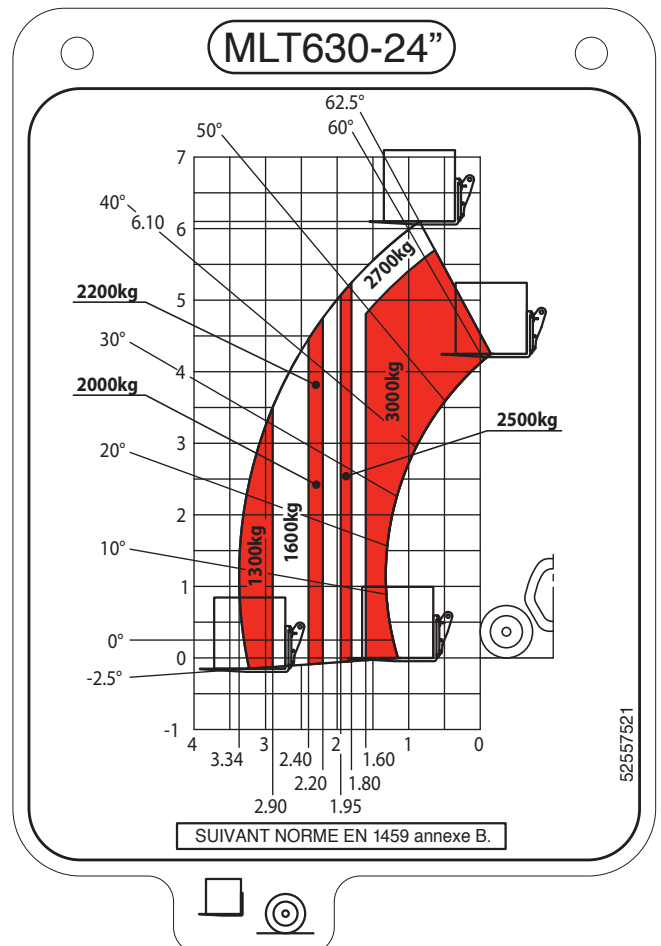
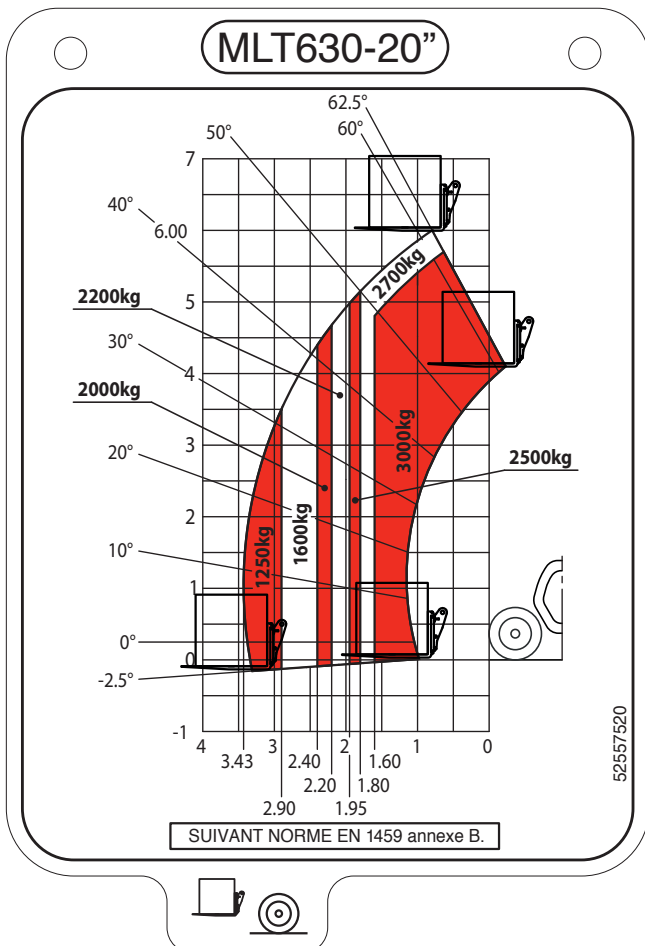

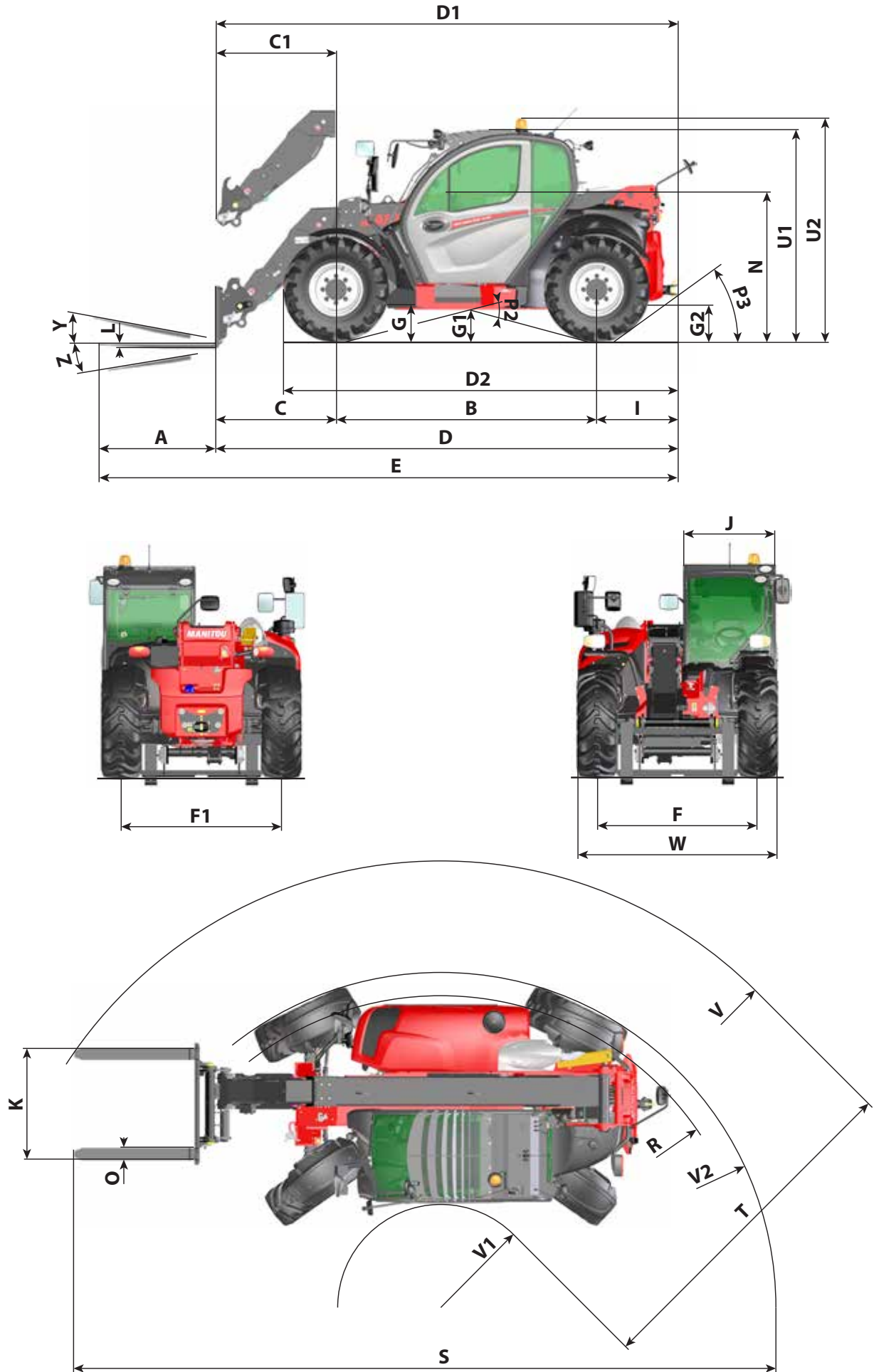

		20" TYRES 400/70 R20	20" TYRES 500/45 R20
<b>A</b>	mm	1200	1200
<b>B</b>	mm	2690	2690
<b>C</b>	mm	1251	1251
<b>C1</b>	mm	1203	1203
<b>D</b>	mm	4784	4784
<b>D1</b>	mm	4736	4736
<b>D2</b>	mm	4069	4008
<b>E</b>	mm	5984	5984
<b>F</b>	mm	1650	1710
<b>F1</b>	mm	1650	1710
<b>G</b>	mm	352	313
<b>G1</b>	mm	283	244
<b>G2</b>	mm	352	313
<b>I</b>	mm	843	843
<b>J</b>	mm	950	950
<b>K</b>	mm	1260	1260
<b>L</b>	mm	45	45
<b>N</b>	mm	1501	1462
<b>O</b>	mm	125	125
<b>P2</b>	°	47	47
<b>P3</b>	°	35	35
<b>R</b>	mm	3440	3440
<b>S</b>	mm	7441	7481
<b>T</b>	mm	3615	3615
<b>U1</b>	mm	2143	2104
<b>U2</b>	mm	2255	2216
<b>V</b>	mm	4955	4955
<b>V1</b>	mm	1340	1340
<b>V2</b>	mm	3645	3685
<b>W</b>	mm	2060	2200
<b>Y</b>	°	13	13
<b>Z</b>	°	133	133

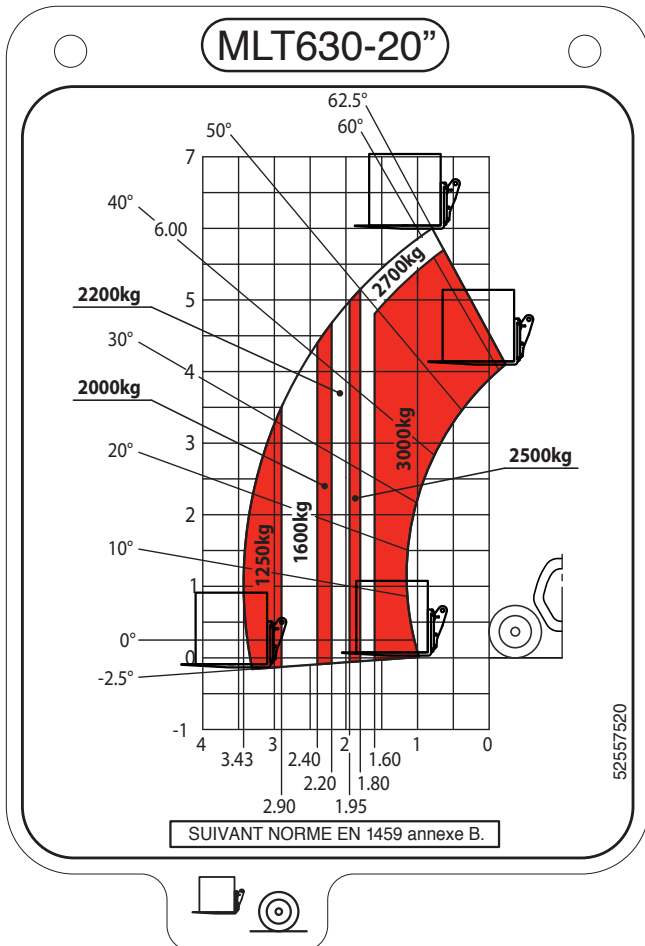

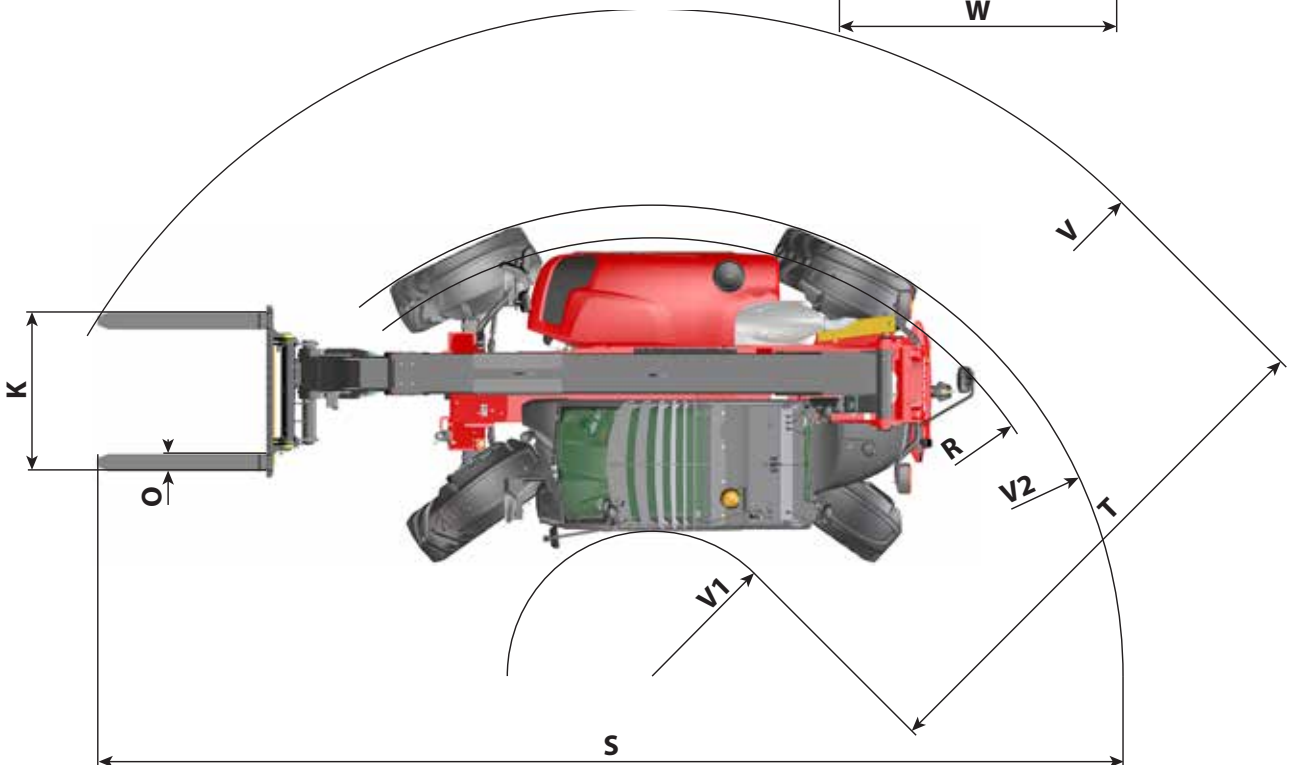
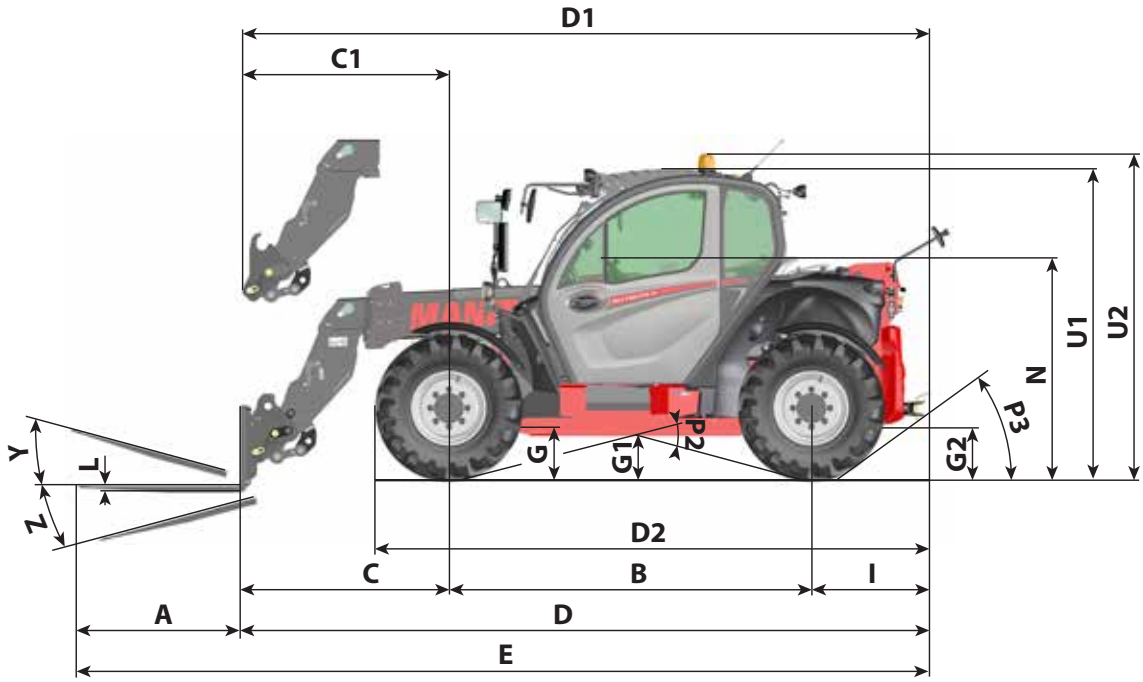

		20" TYRES 400/70 R20	24" TYRES 405/70 R24	24" TYRES 460/70 R24
<b>A</b>	mm	1200	1200	1200
<b>B</b>	mm	2690	2690	2690
<b>C</b>	mm	1550	1550	1550
<b>C1</b>	mm	1455	1455	1455
<b>D</b>	mm	5083	5083	5083
<b>D1</b>	mm	4988	4988	4988
<b>D2</b>	mm	4069	4121	4158
<b>E</b>	mm	6283	6283	6283
<b>F</b>	mm	1650	1730	1690
<b>F1</b>	mm	1650	1730	1690
<b>G</b>	mm	352	457	457
<b>G1</b>	mm	283	388	388
<b>G2</b>	mm	352	457	457
<b>I</b>	mm	843	843	843
<b>J</b>	mm	950	950	950
<b>K</b>	mm	1260	1260	1260
<b>L</b>	mm	45	45	45
<b>N</b>	mm	1621	1726	1726
<b>O</b>	mm	125	125	125
<b>P2</b>	°	47	37	37
<b>P3</b>	°	35	42	42
<b>R</b>	mm	3440	3480	3460
<b>S</b>	mm	7740	7776	7786
<b>T</b>	mm	3690	3680	3680
<b>U1</b>	mm	2263	2368	2368
<b>U2</b>	mm	2375	2480	2480
<b>V</b>	mm	5030	5030	5030
<b>V1</b>	mm	1340	1340	1340
<b>V2</b>	mm	3645	3681	3691
<b>W</b>	mm	2060	2132	2152
<b>Y</b>	°	13	13	13
<b>Z</b>	°	133	133	133

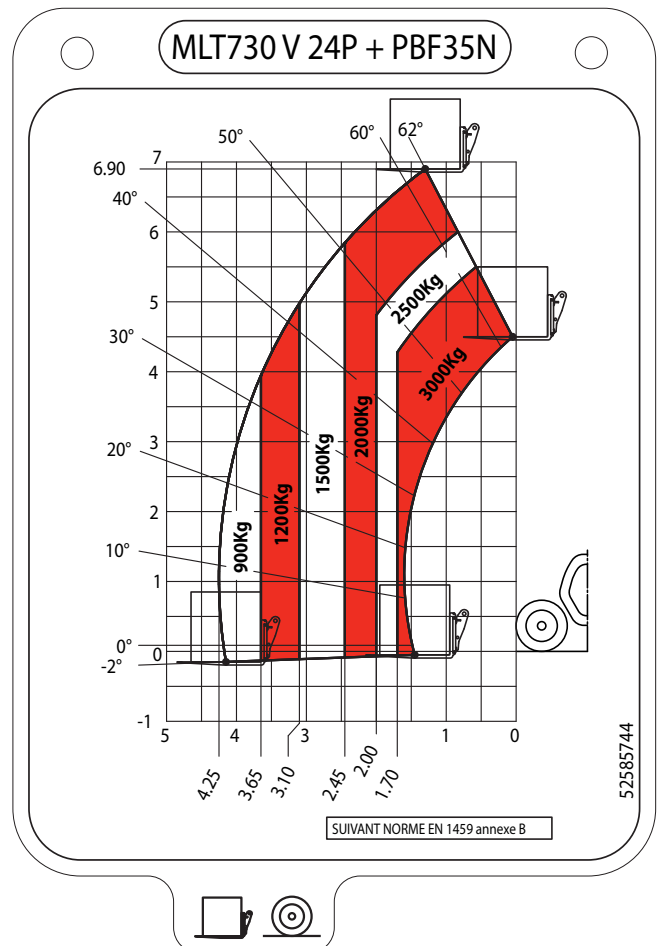
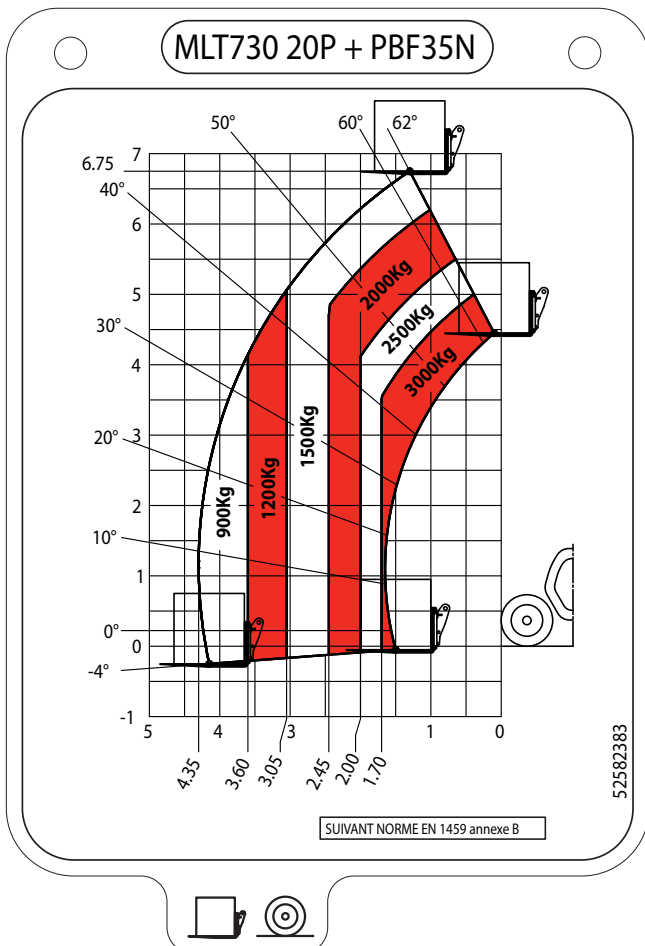

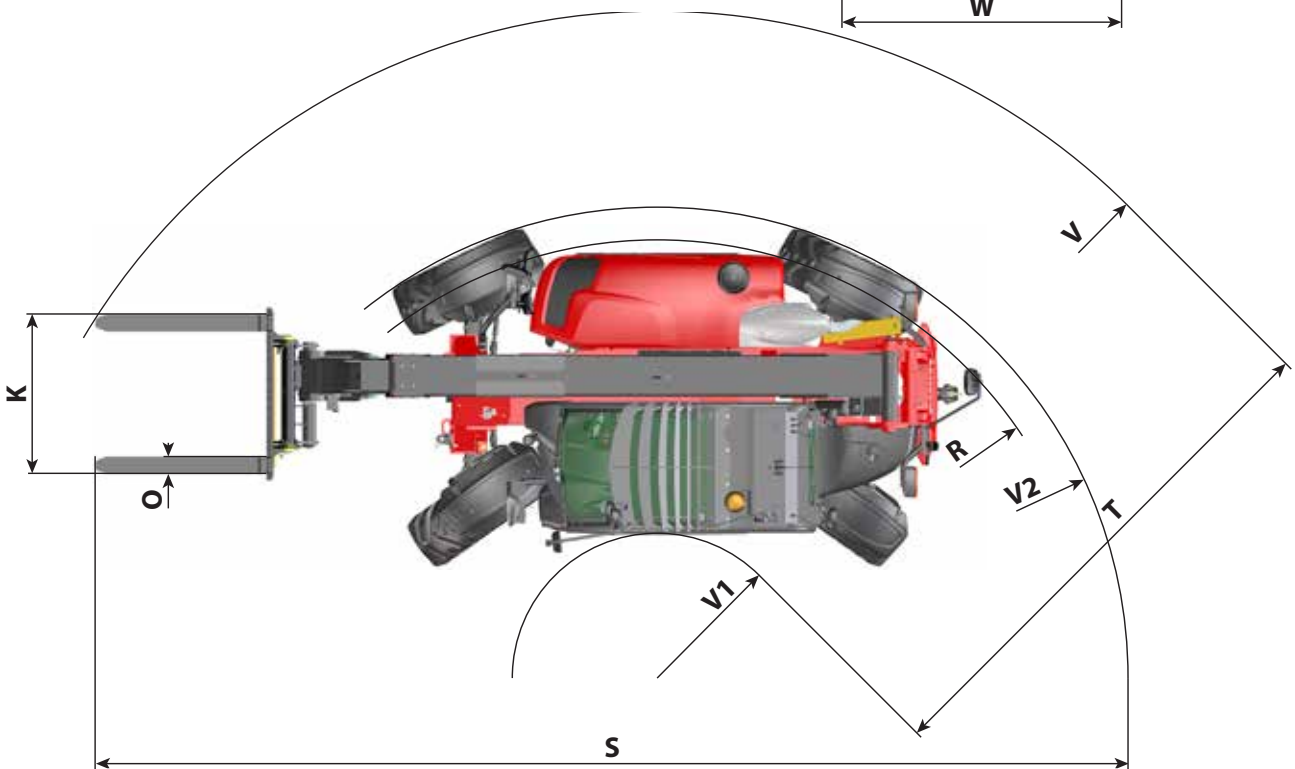
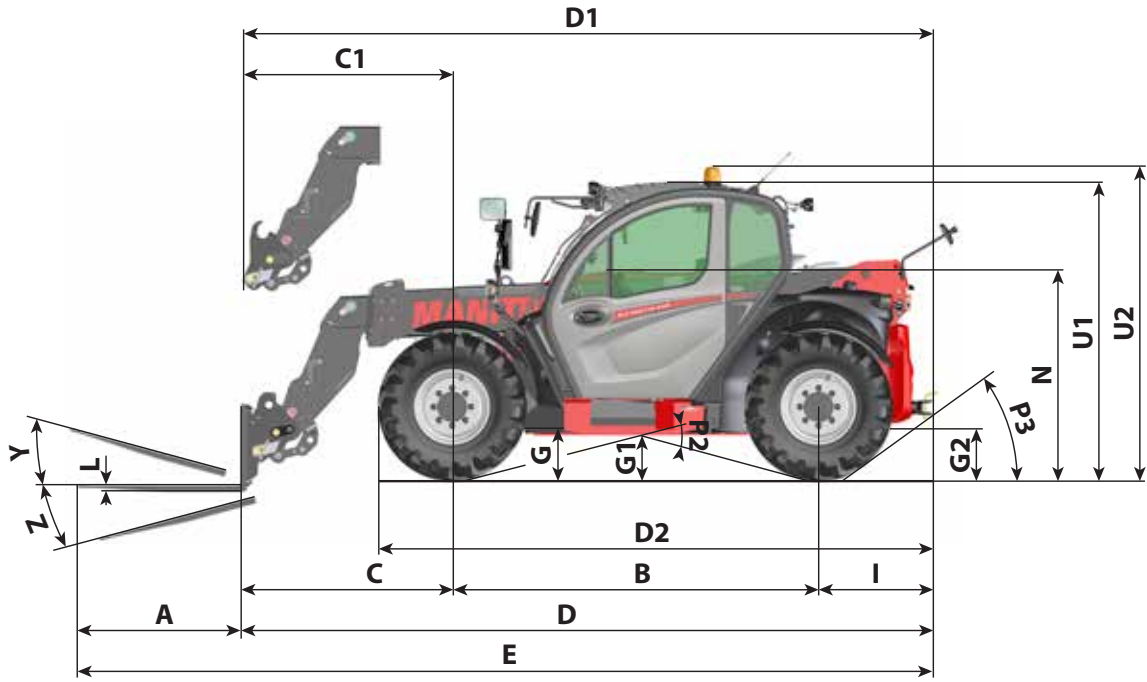

		20" TYRES 400/70 R20	20" TYRES 500/45 R20
A	mm	1200	1200
B	mm	2690	2690
C	mm	1550	1550
C1	mm	1455	1455
D	mm	5083	5083
D1	mm	4988	4988
D2	mm	4069	4008
E	mm	6283	6283
F	mm	1650	1710
F1	mm	1650	1710
G	mm	352	313
G1	mm	283	244
G2	mm	352	313
I	mm	843	843
J	mm	950	950
K	mm	1260	1260
L	mm	45	45
N	mm	1501	1449
O	mm	125	125
P2	°	47	47
P3	°	35	35
R	mm	3440	3440
S	mm	7740	7780
T	mm	3690	3690
U1	mm	2143	2091
U2	mm	2255	2203
V	mm	5030	5030
V1	mm	1340	1340
V2	mm	3645	3685
W	mm	2060	2200
Y	°	13	13
Z	°	133	133

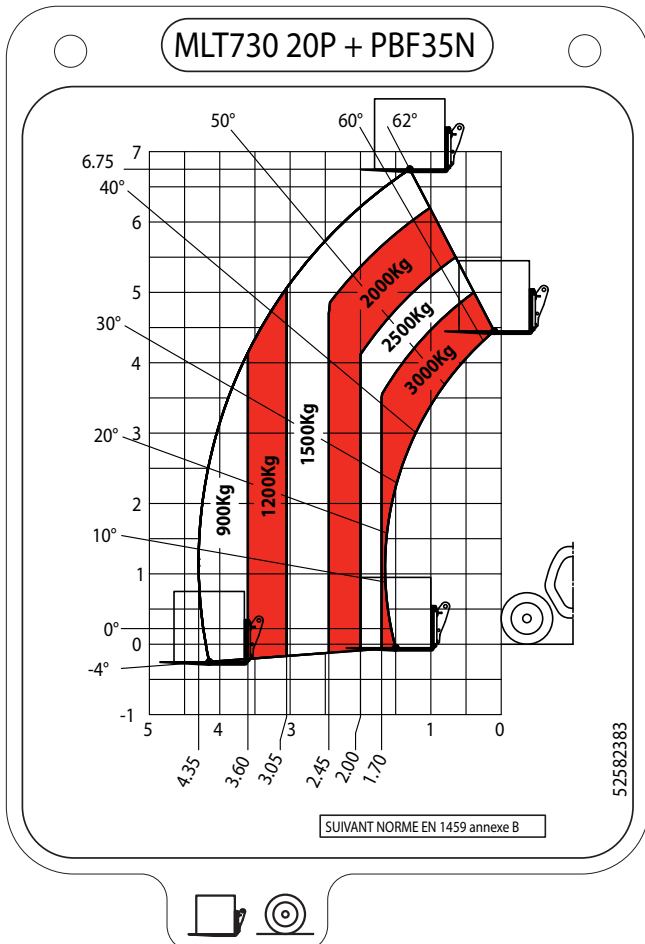

We use European standard EN15830 relating to operator visibility.

- Adhere to the instructions for optimising operator visibility in the immediate vicinity ( $\leq 1$  - OPERATING AND SAFETY INSTRUCTIONS: INSTRUCTIONS TO THE OPERATOR: DRIVING INSTRUCTIONS UNLADEN AND LADEN: D - VISIBILITY).

**DESCRIPTION AND ADJUSTMENT OF REAR-VIEW MIRRORS**

- 1 - LEFT REAR-VIEW MIRROR
- 2 - MAIN RIGHT REAR-VIEW MIRROR
- 3 - SECONDARY RIGHT REAR-VIEW MIRROR
- 4 - RIGHT SIDE REAR-VIEW MIRROR
- 5 - INSIDE REAR-VIEW MIRROR
- 6 - REAR-VIEW MIRROR

- Place the lift truck on level ground with the engine stopped, and the boom retracted and lowered as far as possible.
- Note the position of the reference points ●●○ in the illustrations, to see and correctly adjust the rear-view mirrors.

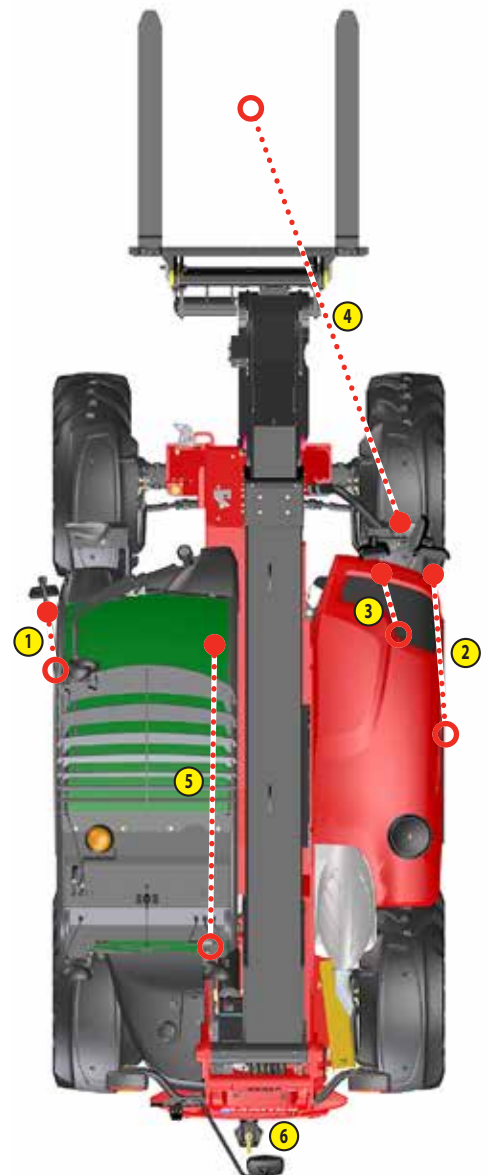
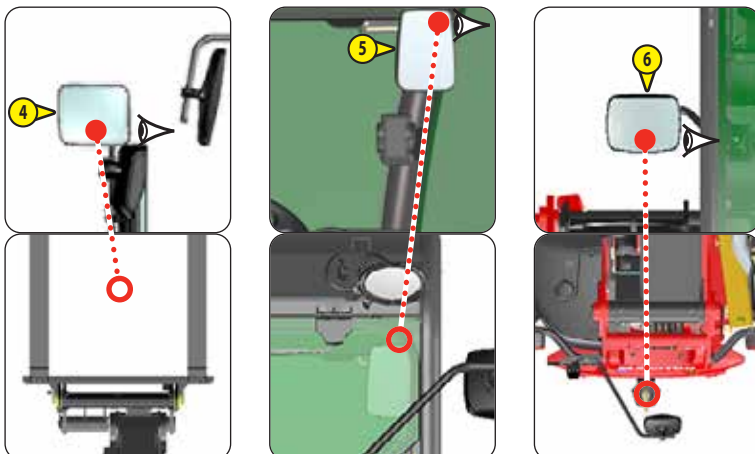
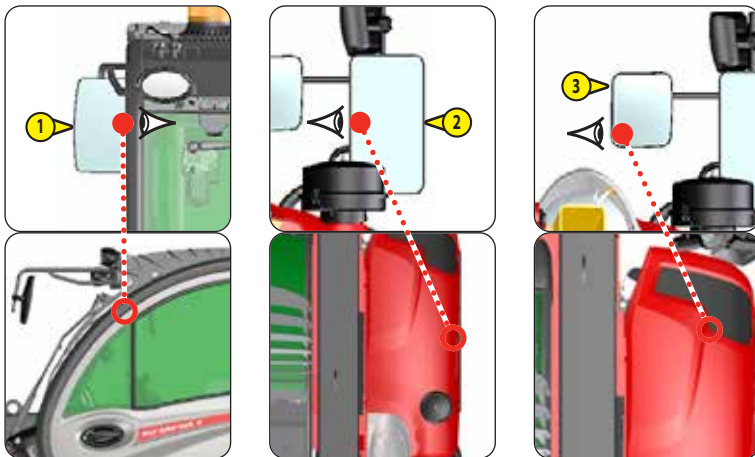
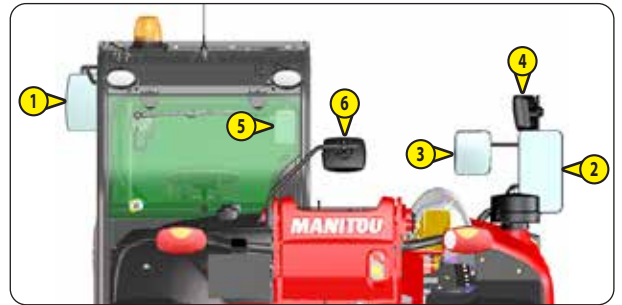

## DIRECT AND/OR INDIRECT VISIBILITY BLIND SPOT ZONES

The two diagrams below indicate blind spot zones on the visibility test circle (12 m radius) and the 1 m rectangular zone around the lift truck, according to tests carried out in accordance with EN 15830.

We draw the attention of the operator to the masking within zone B of the visibility test circle, which could conceal an obstacle or a pedestrian. The operator must manoeuvre the lift truck with utmost care when turning to the left.

### **HANDLING SUSPENDED LOADS** (Test carried out in accordance with 6.3.3 of EN 15830)

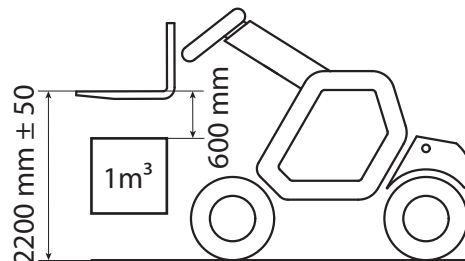

### **LOADING THE TRAILER** (Test carried out in accordance with 6.3.4 of EN 15830)

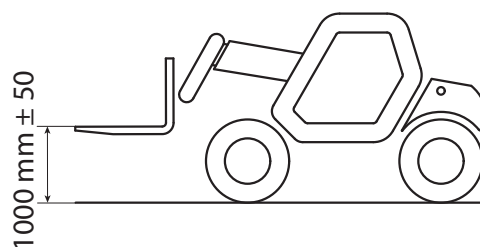

We use European standard EN15830 relating to operator visibility.

- Adhere to the instructions for optimising operator visibility in the immediate vicinity ( $\leq 1$  - OPERATING AND SAFETY INSTRUCTIONS: INSTRUCTIONS TO THE OPERATOR: DRIVING INSTRUCTIONS UNLADEN AND LADEN: D - VISIBILITY).

**DESCRIPTION AND ADJUSTMENT OF REAR-VIEW MIRRORS**

- 1 - LEFT REAR-VIEW MIRROR
- 2 - MAIN RIGHT REAR-VIEW MIRROR
- 3 - SECONDARY RIGHT REAR-VIEW MIRROR
- 4 - RIGHT SIDE REAR-VIEW MIRROR
- 5 - INSIDE REAR-VIEW MIRROR
- 6 - REAR-VIEW MIRROR

- Place the lift truck on level ground with the engine stopped, and the boom retracted and lowered as far as possible.
- Note the position of the reference points ●...○ in the illustrations, to see and correctly adjust the rear-view mirrors.

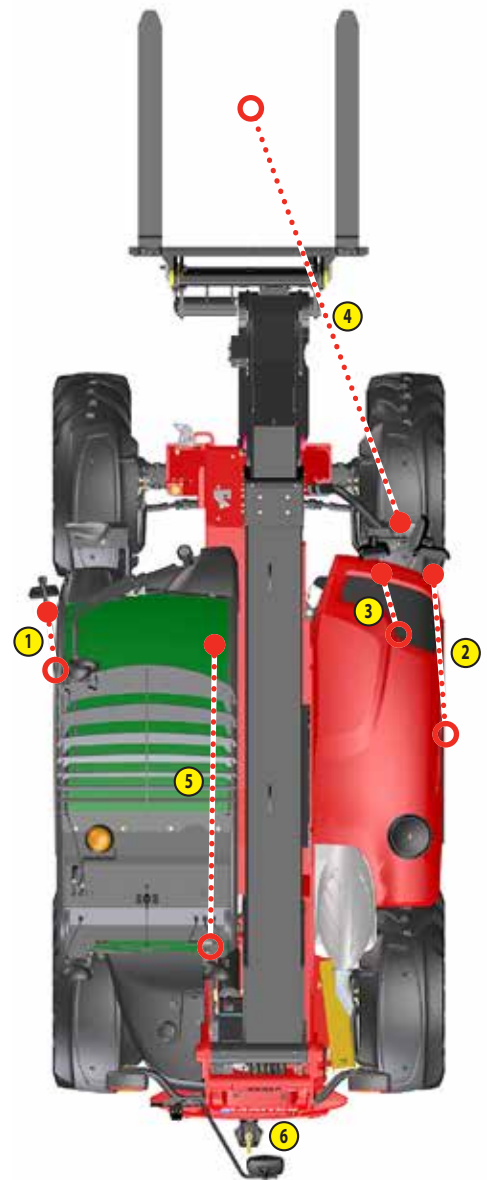
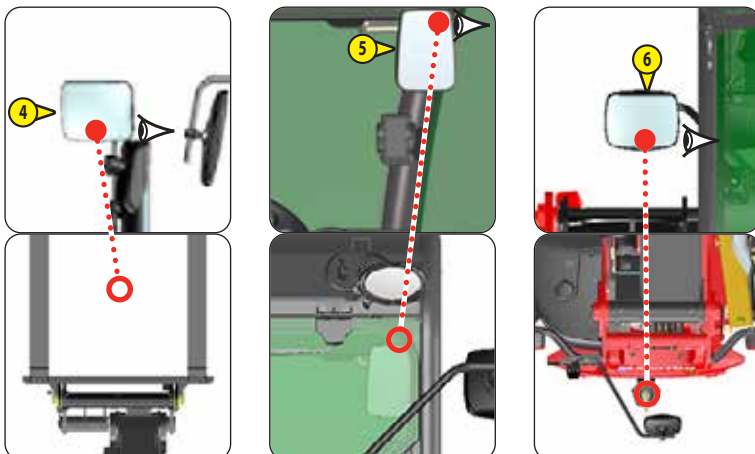
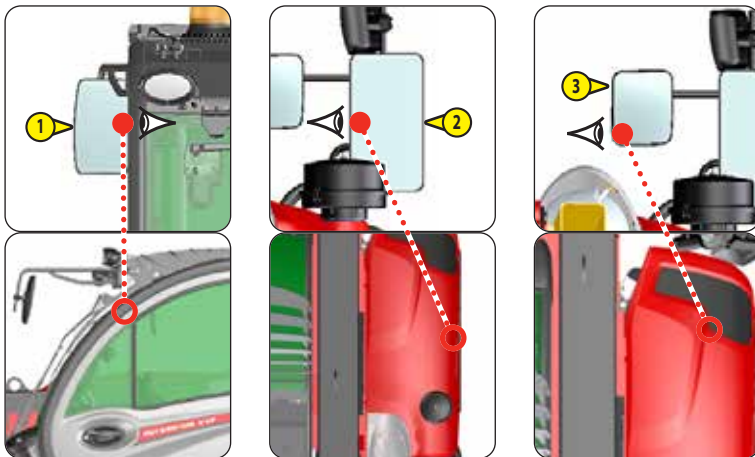
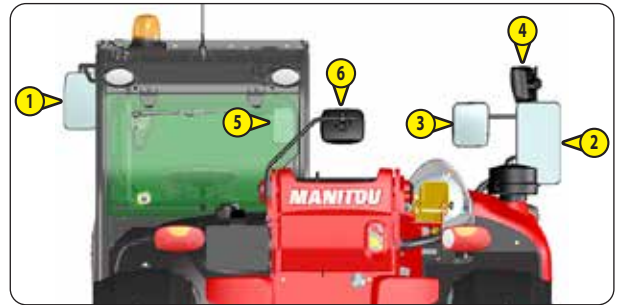

## DIRECT AND/OR INDIRECT VISIBILITY BLIND SPOT ZONES

The two diagrams below indicate blind spot zones on the visibility test circle (12 m radius) and the 1 m rectangular zone around the lift truck, according to tests carried out in accordance with EN 15830.

We draw the attention of the operator to the masking within zone B of the visibility test circle, which could conceal an obstacle or a pedestrian. The operator must manoeuvre the lift truck with utmost care when turning to the left.

### **HANDLING SUSPENDED LOADS** (Test carried out in accordance with 6.3.3 of EN 15830)

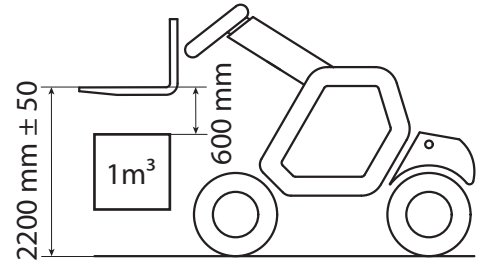

### **LOADING THE TRAILER** (Test carried out in accordance with 6.3.4 of EN 15830)

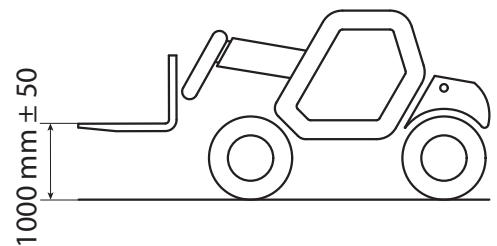

We use European standard EN15830 relating to operator visibility.

- Adhere to the instructions for optimising operator visibility in the immediate vicinity (<math>\leq 1</math> - OPERATING AND SAFETY INSTRUCTIONS: INSTRUCTIONS TO THE OPERATOR: DRIVING INSTRUCTIONS UNLADEN AND LADEN: D - VISIBILITY).

**DESCRIPTION AND ADJUSTMENT OF REAR-VIEW MIRRORS**

- 1 - LEFT REAR-VIEW MIRROR
- 2 - MAIN RIGHT REAR-VIEW MIRROR
- 3 - SECONDARY RIGHT REAR-VIEW MIRROR
- 4 - RIGHT SIDE REAR-VIEW MIRROR
- 5 - INSIDE REAR-VIEW MIRROR
- 6 - REAR-VIEW MIRROR

- Place the lift truck on level ground with the engine stopped, and the boom retracted and lowered as far as possible.
- Note the position of the reference points ●○○ in the illustrations, to see and correctly adjust the rear-view mirrors.

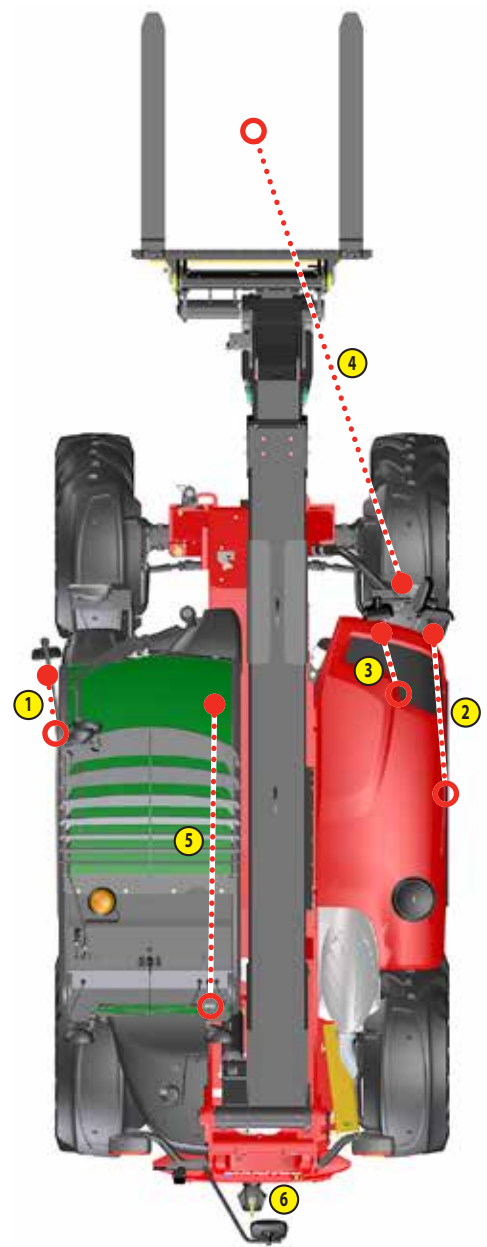
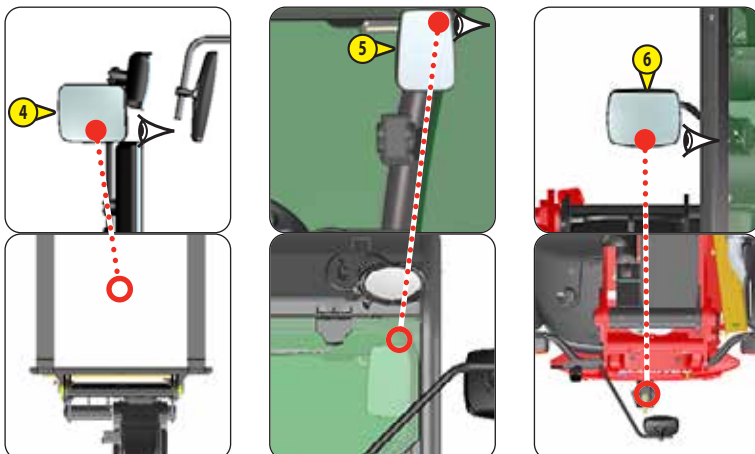
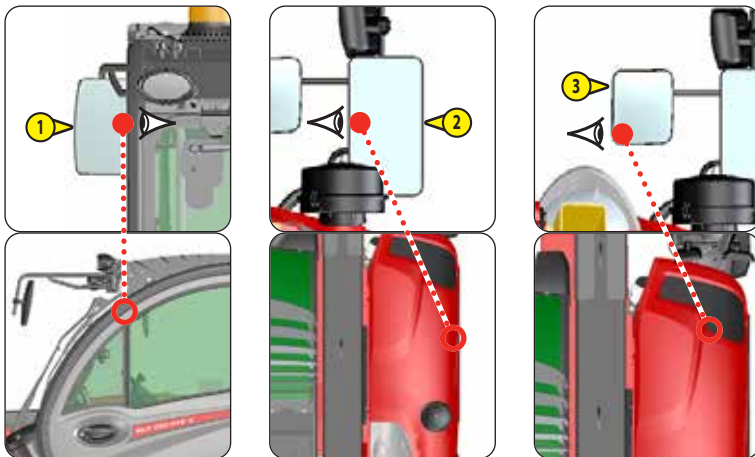
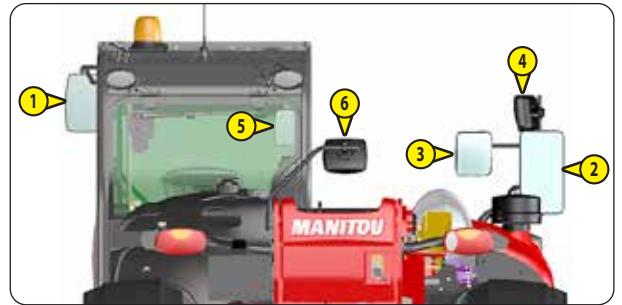

**DIRECT AND/OR INDIRECT VISIBILITY BLIND SPOT ZONES**

The two diagrams below indicate blind spot zones on the visibility test circle (12 m radius) and the 1 m rectangular zone around the lift truck, according to tests carried out in accordance with EN 15830.

We draw the attention of the operator to the masking within zone B of the visibility test circle, which could conceal an obstacle or a pedestrian. The operator must manoeuvre the lift truck with utmost care when turning to the left.

**HANDLING SUSPENDED LOADS** (Test carried out in accordance with 6.3.3 of EN 15830)

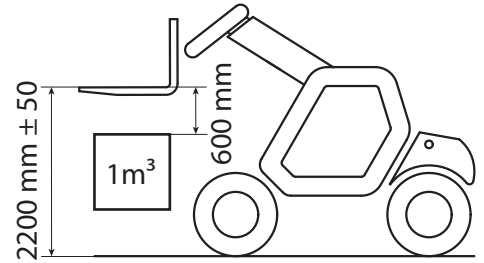

**LOADING THE TRAILER** (Test carried out in accordance with 6.3.4 of EN 15830)

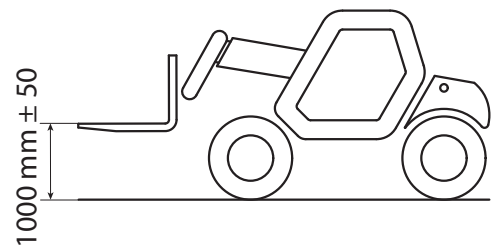

We use European standard EN15830 relating to operator visibility.

- Adhere to the instructions for optimising operator visibility in the immediate vicinity ( $\leq 1$  - OPERATING AND SAFETY INSTRUCTIONS: INSTRUCTIONS TO THE OPERATOR: DRIVING INSTRUCTIONS UNLADEN AND LADEN: D - VISIBILITY).

**DESCRIPTION AND ADJUSTMENT OF REAR-VIEW MIRRORS**

- 1 - LEFT REAR-VIEW MIRROR
- 2 - MAIN RIGHT REAR-VIEW MIRROR
- 3 - SECONDARY RIGHT REAR-VIEW MIRROR
- 4 - RIGHT SIDE REAR-VIEW MIRROR
- 5 - INSIDE REAR-VIEW MIRROR
- 6 - REAR-VIEW MIRROR

- Place the lift truck on level ground with the engine stopped, and the boom retracted and lowered as far as possible.
- Note the position of the reference points ●...○ in the illustrations, to see and correctly adjust the rear-view mirrors.

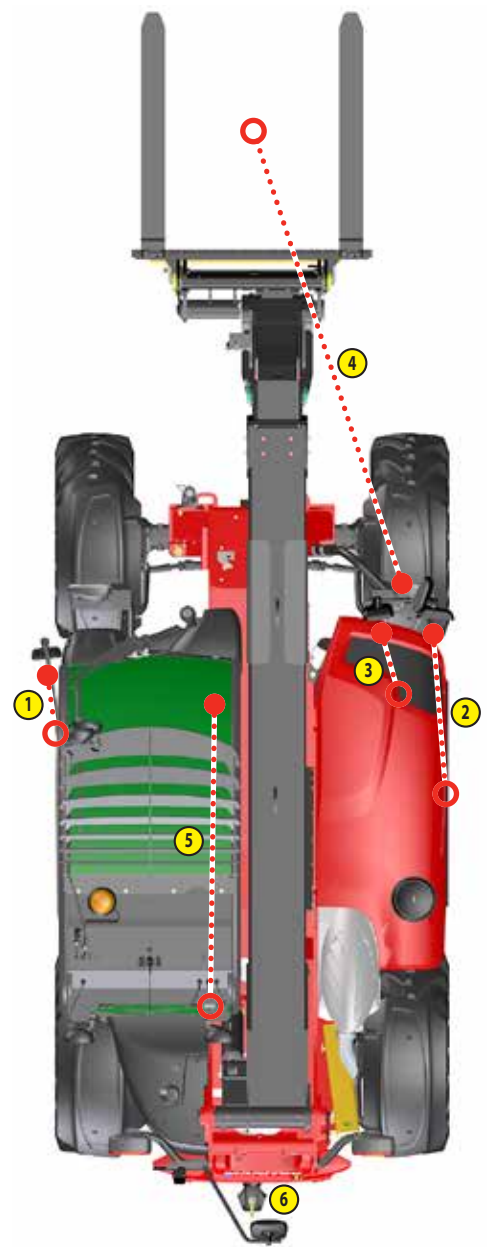
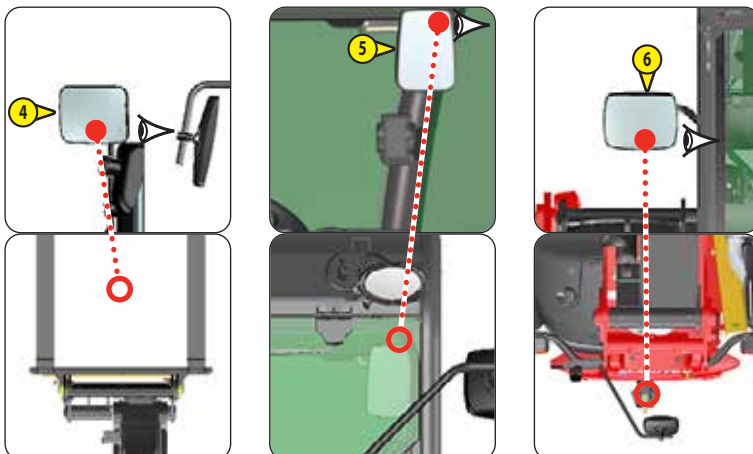
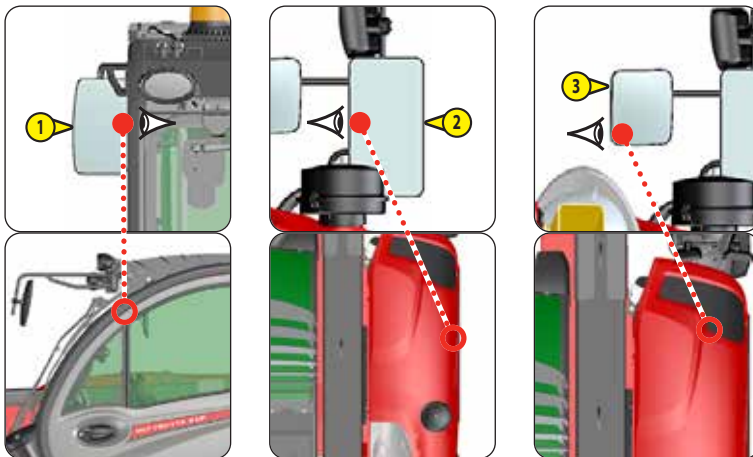
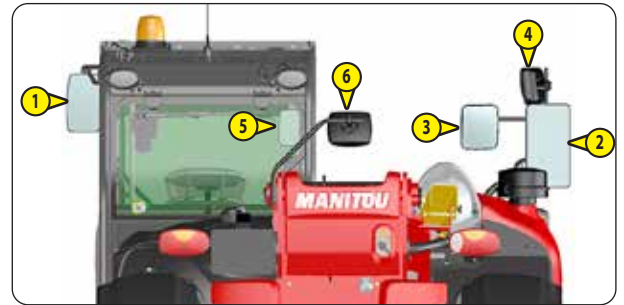

## DIRECT AND/OR INDIRECT VISIBILITY BLIND SPOT ZONES

The two diagrams below indicate blind spot zones on the visibility test circle (12 m radius) and the 1 m rectangular zone around the lift truck, according to tests carried out in accordance with EN 15830.

We draw the attention of the operator to the masking within zone B of the visibility test circle, which could conceal an obstacle or a pedestrian. The operator must manoeuvre the lift truck with utmost care when turning to the left.

### **HANDLING SUSPENDED LOADS** (Test carried out in accordance with 6.3.3 of EN 15830)

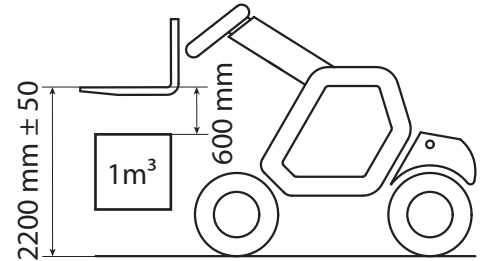

### **LOADING THE TRAILER** (Test carried out in accordance with 6.3.4 of EN 15830)

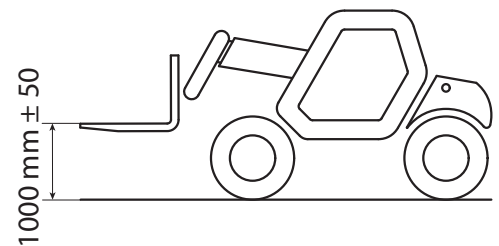

# INSTRUMENTS AND CONTROLS

## DESCRIPTION

NOTE: All the terms such as: RIGHT, LEFT, FRONT, REAR are as seen by an observer occupying the driver's seat and looking straight ahead.

1 - DRIVER'S SEAT .....	2-54
2 - SEAT BELT .....	2-58
3 - IGNITION SWITCH .....	2-58
4 - EMERGENCY STOP .....	2-58
5 - DASHBOARD "HARMONY" .....	2-59
6 - DASHBOARD "VISION" .....	2-63
7 - LONGITUDINAL STABILITY LIMITER AND WARNING DEVICE .....	2-67
8 - INFORMATION SCREEN CONTROL CONSOLE .....	2-69
9 - PUSH BUTTON PANEL .....	2-70
10 - SWITCHES .....	2-71
11 - LIGHTING, HORN AND INDICATOR SWITCH .....	2-72
12 - FRONT AND REAR WINDSCREEN WIPER SWITCH .....	2-72
13 - STEERING SELECTION .....	2-72
14 - FUSES AND RELAYS IN THE CAB .....	2-73
15 - FUSES AND RELAYS UNDER THE ENGINE COVER .....	2-75
16 - DIAGNOSTIC PLUG .....	2-75
17 - ACCELERATOR PEDAL .....	2-75
18 - SERVICE BRAKE PEDAL AND TRANSMISSION CUT-OFF .....	2-75
19 - GEAR SELECTOR .....	2-76
20 - PARKING BRAKE LEVER .....	2-76
21 - FORWARD/NEUTRAL/REVERSE GEAR SELECTION .....	2-76
22 - HYDRAULIC CONTROLS .....	2-77
23 - FUNCTION FILES .....	2-78
24 - LEVEL INDICATOR .....	2-78
25 - HEATER CONTROL .....	2-78
26 - AIR CONDITIONING CONTROLS (AIR CONDITIONING OPTION) .....	2-79
27 - WINDSCREEN DEMISTER VENTS .....	2-80
28 - HEATING VENTS .....	2-80
29 - STEERING WHEEL ADJUSTMENT LEVER .....	2-80
30 - DOOR OPENING AND CLOSING HANDLE .....	2-80
31 - WINDOW WINDER .....	2-80
32 - REAR WINDOW STAY .....	2-80
33 - STORAGE NET .....	2-80
34 - STORAGE .....	2-80
35 - SUN VISOR .....	2-81
36 - ROOF LIGHT .....	2-81
37 - HOOK .....	2-81
38 - INSIDE REAR-VIEW MIRROR .....	2-81
39 - TELEPHONE HOLDER .....	2-81
40 - CIGARETTE LIGHTER .....	2-81
41 - USB RECHARGING SOCKET .....	2-81
42 - ARMREST AND STORAGE .....	2-81
43 - EMERGENCY EXIT .....	2-81
44 - BATTERY .....	2-82
45 - BATTERY CUT-OFF .....	2-82
46 - FRONT HEADLIGHTS .....	2-82
47 - REAR LIGHTS .....	2-82
48 - ROTATING BEACON LIGHT .....	2-82
49 - BOOM SAFETY WEDGE .....	2-82
50 - FUEL TANK .....	2-83
51 - TANK "DEF" (Diesel Exhaust Fluid) .....	2-83

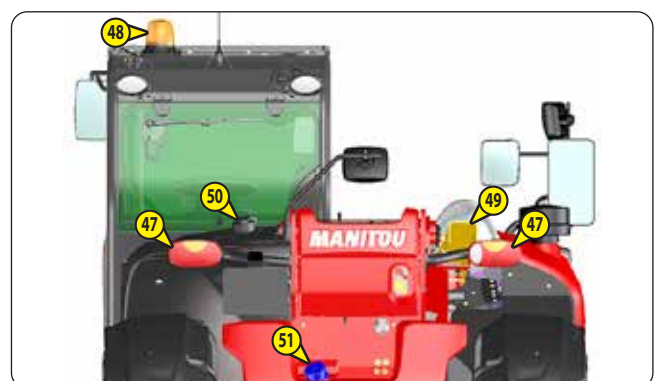
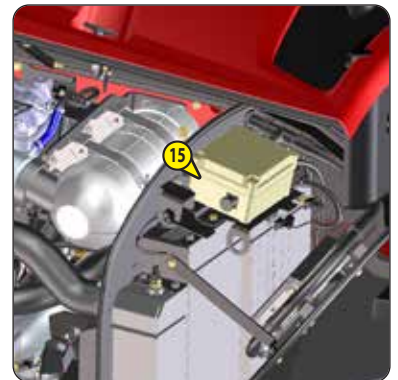
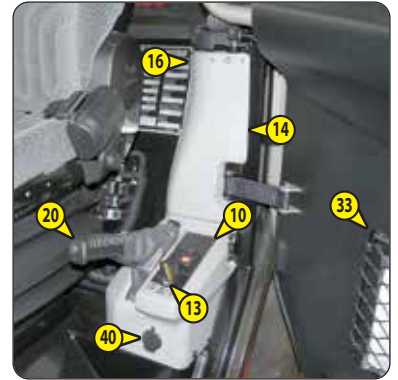

## 1 - DRIVER'S SEAT

### DRIVER'S SEAT "CLASSIC"

DESIGNED FOR MAXIMUM COMFORT, THIS SEAT CAN BE ADJUSTED AS FOLLOWS.

#### WEIGHT ADJUSTMENT

It is advised that the weight be adjusted when the driver is not sitting in the cab.

- Refer to graduation 1 of the seat.
- Turn handle 2 according to the driver's weight.

NOTE: To avoid any health problems, it is recommended that the weight setting is checked and adjusted before starting the lift truck.

#### EXTENDING THE HEAD-REST

- The height of the head-rest 3 can be adjusted by pulling it upwards (the notches will click) up to the stop.
- The head-rest can be removed by applying sufficient pressure to pull it off the stop.

#### BACK-REST ANGLE ADJUSTMENT



*If you do not support the back-rest when making adjustments, it swings completely forwards.*

- Support the back-rest, pull the lever 4 and tilt the back-rest to the desired position.

#### LONGITUDINAL ADJUSTMENT

- Engage the locking lever 5 in the desired position. This then locks, preventing the seat from being moved into another position.

#### MAINTENANCE



*A moving backrest increases the risk of an accident!*

Dirt may adversely affect the correct functioning of the seat. For this reason, make sure your seat is always clean.

- To clean or change the cushions, simply remove them from the seat frame.
- Avoid wetting the cushion fabric when cleaning it. Firstly check the resistance of the fabric on a small hidden area before using any fabric or plastic cleaner.



## PNEUMATIC DRIVER'S SEAT "PREMIUM"

DESIGNED FOR MAXIMUM COMFORT, THIS SEAT CAN BE ADJUSTED AS FOLLOWS.

### WEIGHT AND SEAT HEIGHT ADJUSTMENT

#### WEIGHT ADJUSTMENT

Adjust the seat according to your weight while correctly seated.

- Switch on lift truck ignition.
- Push or pull lever 1 until green appears in display 2 indicating correct adjustment according to your weight.

NOTE: To avoid any health problems, it is recommended that the weight setting is checked and adjusted before starting the lift truck.

#### SEAT HEIGHT ADJUSTMENT

#### **⚠ IMPORTANT ⚠**

*To avoid causing any damage, do not activate the compressor for over 1 minute.*

When weight adjustment has been carried out, you can then modify seat height.

- Keep the ignition on in the lift truck.
- Push or pull lever 1 until green appears and adjust the height of the seat while checking that the green in display 2 remains visible.

#### EXTENDING THE HEAD-REST

- The height of the head-rest 3 can be adjusted by pulling it upwards (the notches will click) up to the stop.
- The head-rest can be removed by applying sufficient pressure to pull it off the stop.

#### BACK-REST ANGLE ADJUSTMENT

#### **⚠ IMPORTANT ⚠**

*If you do not support the back-rest when making adjustments, it swings completely forwards.*

- Support the back-rest, pull the lever 4 and tilt the back-rest to the desired position.

#### LONGITUDINAL ADJUSTMENT

- Engage the locking lever 5 in the desired position. This then locks, preventing the seat from being moved into another position.

#### MAINTENANCE

#### **⚠ IMPORTANT ⚠**

*A moving backrest increases the risk of an accident!*

Dirt may adversely affect the correct functioning of the seat. For this reason, make sure your seat is always clean.

- To clean or change the cushions, simply remove them from the seat frame.
- Avoid wetting the cushion fabric when cleaning it. Firstly check the resistance of the fabric on a small hidden area before using any fabric or plastic cleaner.



## PNEUMATIC DRIVER'S SEAT "ÉLITE"

DESIGNED FOR MAXIMUM COMFORT, THIS SEAT CAN BE ADJUSTED AS FOLLOWS.

### WEIGHT AND SEAT HEIGHT ADJUSTMENT

#### **⚠ IMPORTANT ⚠**

*To avoid causing any damage, do not activate the compressor for over 1 minute.*

#### WEIGHT ADJUSTMENT

Adjust the seat according to your weight while correctly seated.

- Switch on lift truck ignition.
- Briefly pull up lever 1 to automatically adjust the seat according to your weight.

NOTE: To avoid any health problems, it is recommended that the weight setting is checked and adjusted before starting the lift truck.

#### SEAT HEIGHT ADJUSTMENT

- Fully push in or pull out lever 1 to adjust the height of the seat. When the upper or lower end stop is reached, the seat automatically adjusts itself, thus minimising the damping stroke.

### HORIZONTAL SHOCK ABSORBER

In certain conditions (e.g. driving with a trailer) it is advised the horizontal shock absorber 2 be used. The driver's seat is thus better able to absorb jerks in the direction of travel.

- Position A: Horizontal shock absorber removed.
- Position B: Horizontal shock absorber fitted.

### EXTENDING THE HEAD-REST

- The height of the head-rest 3 can be adjusted by pulling it upwards (the notches will click) up to the stop.
- The head-rest can be removed by applying sufficient pressure to pull it off the stop.

### BACK-REST ANGLE ADJUSTMENT

#### **⚠ IMPORTANT ⚠**

*If you do not support the back-rest when making adjustments, it swings completely forwards.*

- Support the back-rest, pull the lever 4 and tilt the back-rest to the desired position.

### LONGITUDINAL ADJUSTMENT

- Engage the locking lever 5 in the desired position. This then locks, preventing the seat from being moved into another position.

### LUMBAR ADJUSTMENT

This increases the comfort of the seat and the driver's freedom of movement.

- Turn the handle 6 either left or right to adjust the height or depth of the lumbar support.

### MAINTENANCE

#### **⚠ IMPORTANT ⚠**

*A moving backrest increases the risk of an accident!*

Dirt may adversely affect the correct functioning of the seat. For this reason, make sure your seat is always clean.

- To clean or change the cushions, simply remove them from the seat frame.
- Avoid wetting the cushion fabric when cleaning it. Firstly check the resistance of the fabric on a small hidden area before using any fabric or plastic cleaner.



## HEATED PNEUMATIC DRIVER'S SEAT "LUXE"

DESIGNED FOR MAXIMUM COMFORT, THIS SEAT CAN BE ADJUSTED AS FOLLOWS.

### WEIGHT AND SEAT HEIGHT ADJUSTMENT

#### ⚠ IMPORTANT ⚠

*To avoid causing any damage, do not activate the compressor for over 1 minute.*

#### WEIGHT ADJUSTMENT

Adjust the seat according to your weight while correctly seated.

- Switch on lift truck ignition.
- Briefly pull up lever 1 to automatically adjust the seat according to your weight.

NOTE: To avoid any health problems, it is recommended that the weight setting is checked and adjusted before starting the lift truck.

#### SEAT HEIGHT ADJUSTMENT

- Fully push in or pull out lever 1 to adjust the height of the seat. When the upper or lower end stop is reached, the seat automatically adjusts itself, thus minimising the damping stroke.

### HORIZONTAL SHOCK ABSORBER

In certain conditions (e.g. driving with a trailer) it is advised the horizontal shock absorber 2 be used. The driver's seat is thus better able to absorb jerks in the direction of travel.

- Position A: Horizontal shock absorber removed.
- Position B: Horizontal shock absorber fitted.

### EXTENDING THE HEAD-REST

- The height of the head-rest 3 can be adjusted by pulling it upwards (the notches will click) up to the stop.
- The head-rest can be removed by applying sufficient pressure to pull it off the stop.

### BACK-REST ANGLE ADJUSTMENT

#### ⚠ IMPORTANT ⚠

*If you do not support the back-rest when making adjustments, it swings completely forwards.*

- Support the back-rest, pull the lever 4 and tilt the back-rest to the desired position.

### LONGITUDINAL ADJUSTMENT

- Engage the locking lever 5 in the desired position. This then locks, preventing the seat from being moved into another position.

### LUMBAR ADJUSTMENT

This increases the comfort of the seat and the driver's freedom of movement.

- The lumbar support in the upper or lower part of the backrest can be separately adjusted by operating the upper or lower switch.
- The curvature of the lumbar adjustment setting is adjusted by pressing "+" or "-" on the corresponding switch 6.
- Release the switch when the desired backrest curvature is achieved.

### HEATING

- Operate switch 7 to enable or disable the seat heating function.

### MAINTENANCE

#### ⚠ IMPORTANT ⚠

*A moving backrest increases the risk of an accident!*

Dirt may adversely affect the correct functioning of the seat. For this reason, make sure your seat is always clean.

- To clean or change the cushions, simply remove them from the seat frame.
- Avoid wetting the cushion fabric when cleaning it. Firstly check the resistance of the fabric on a small hidden area before using any fabric or plastic cleaner.



## 2 - SEAT BELT

---

### **⚠ IMPORTANT ⚠**

*Under no circumstances must the lift truck be used if the seat belt is defective (fixing, locking, cuts, tears, etc.).  
Immediately repair or replace the seat belt.*

- Sit correctly on the seat.
- Check that seat belt is not twisted.
- Place the seat belt at hip level.
- Attach the seat belt and check that it locks.
- Adjust the seat belt to your body shape without compressing your pelvis and without excessive slack.

## 3 - IGNITION SWITCH

---

This switch has 5 positions:

- P - Not used.
- O - Ignition switched off and engine stopped.
- I - Ignition + preheat.
- II - Not used.
- III - Start-up and returns to position I as soon as the key is released.

## 4 - EMERGENCY STOP

---

In the event of danger, it enables the engine to be shut down, thereby cutting-off all hydraulic movements.

### **⚠ IMPORTANT ⚠**

*Be ready for hydraulic movements suddenly stopping when you press this button.  
If possible stop the lift truck before using the emergency stop button.*

- Turn switch to disable.

## 5 - DASHBOARD "HARMONY"

### 5A - INSTRUMENTS AND INDICATORS

### 5B - INFORMATION SCREEN



### 5A - INSTRUMENTS AND INDICATORS

#### A - REV COUNTER

#### B - ENGINE WATER TEMPERATURE

If the indicator lamp  lights when the lift truck is running, this means that the coolant temperature is high. Stop the engine immediately and seek the cause of the cooling system malfunction.

#### C - FUEL LEVEL

Indicator lamp , indicates that you are in reserve and that your running time is limited.

#### D - LEVEL "DEF" (Diesel Exhaust Fluid)

The indicator lamp  lights if the level is below 15%.

 **MAIN BEAM INDICATOR LAMP**

 **LOW BEAM INDICATOR LAMP**

 **INDICATOR LIGHTS INDICATOR LAMP**

 **PARKING BRAKE INDICATOR LAMP**

This indicator lamp comes on when the parking brake is applied.

 **BATTERY CHARGE WARNING INDICATOR LAMP**

If the lamp and the buzzer come on when the lift truck is running, stop the engine immediately and seek the cause (electric circuit, alternator belt, alternator, etc.).

 **STEERING SYSTEM OIL PRESSURE WARNING INDICATOR LAMP**

If the lamp comes on when the lift truck is running, stop the engine immediately and determine the cause (possible leak, etc.).

 **WATER IN FUEL PRE-FILTER WARNING INDICATOR LAMP**

This light will come on when there is water in the fuel pre-filter. Stop the lift truck and carry out the necessary repairs.

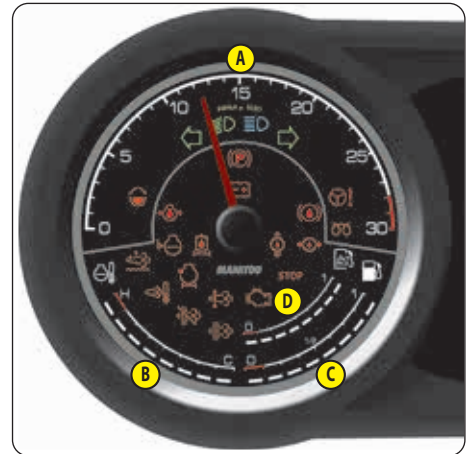



### **BRAKE FLUID LEVEL WARNING INDICATOR LAMP**

If the indicator lamp and buzzer come on, when the lift truck is running, stop the engine immediately and determine the cause (brake fluid level, possible leak, etc.). In the event of an abnormal drop in the level, consult your dealer.



### **ENGINE OIL PRESSURE WARNING INDICATOR LAMP**

If the indicator lamp comes on when the forklift truck is operating, stop the engine immediately and look for the cause (oil level in engine crankcase).

NOTE: After starting the engine, the indicator lamp remains lit for a few seconds then goes out when the correct engine oil pressure is reached. The full engine power is then available.



### **ENGINE PREHEAT INDICATOR LAMP**

Preheat is necessary. When the lift truck is switched on, the indicator lamp comes on for 2 seconds and goes off as soon as preheat is ended. Start the lift truck's engine.



### **GEAR BOX OIL PRESSURE WARNING INDICATOR LAMP**

The indicator lamp and buzzer come on when there is an abnormal drop in gear box pressure, in forward gear. Stop the engine and determine the cause (gear box oil level, possible leak, radiator, etc.).

NOTE: This indicator lamp operates in forward travel conditions only, and can be ignored when the lift truck is stopped with the engine running at min rpm.



### **GEAR BOX OIL TEMPERATURE WARNING INDICATOR LAMP**

The indicator lamp and buzzer come on when the gear box oil temperature is abnormally high. Stop the engine and determine the cause (gear box oil level, possible leak, radiator, etc.).



### **HYDRAULIC RETURN FILTER CLOGGING FAULT INDICATOR LAMP**

The indicator lamp and the buzzer come on when the hydraulic return oil filter cartridge is clogged. Stop the engine and carry out the necessary repairs (3 - MAINTENANCE: FILTER CARTRIDGES AND BELTS).



### **ENGINE WATER LEVEL WARNING INDICATOR LAMP**

If the indicator lamp and buzzer come on when the lift truck is running, stop the engine immediately and determine the cause (coolant level, possible leak, radiator, etc.).



### **ENGINE STOPPED WARNING INDICATOR LAMP**

If the indicator lamp lights up or flashes, when the lift truck is running, stop the engine immediately and consult your dealer.



### **AIR FILTER CLOGGING WARNING INDICATOR LAMP**

The lamp and the buzzer come on when the air filter cartridge is clogged up. Stop the lift truck and carry out the necessary repairs (3 - MAINTENANCE: FILTER CARTRIDGES AND BELTS).







### **ENGINE FAULT INDICATOR LAMP**

If the indicator lamp comes on or flashes while the lift truck is in operation, a diagnostic fault has been detected. The lift truck will operate in reduced mode. Consult your dealer without delay.



### FAULT INDICATOR LAMP "SCR" (selective catalytic reduction)

The indicator lamp lights up if the system efficiency or the quality of the diesel exhaust fluid is defective.

Flashing  indicator lamp +  + audible signal	- Diesel exhaust fluid level is below 10%.
 +  + audible signal	- Consult your dealer as soon as possible.









### CRYSTALLISATION OR SULPHURISATION LEVEL

If the indicator lamp flashes while the lift truck is running, perform a "STATIONARY LIFT TRUCK" EXHAUST SUBLIMATION (↔ 3 - MAINTENANCE: 1000H - PERIODIC MAINTENANCE - EVERY 1,000 HOURS OF SERVICE OR EVERY 2 YEARS).

NOTE: This indicator lamp also lights up every 1,000 hours so as to perform a "STATIONARY LIFT TRUCK" EXHAUST SUBLIMATION.

### 5B - INFORMATION SCREEN







- ①  **BOOM ANGLE**
- ②  **MAINTENANCE REQUIRED**
- ③  **MAINTENANCE REQUIRED + ERROR CODE NUMBER**
- ④  **HYDRAULIC MOVEMENT NEUTRALISATION**
- ⑤  **DISABLING "AGGRAVATING" HYDRAULIC MOVEMENT CUT-OFF**
- ④  **FORWARD/NEUTRAL/REVERSE GEAR AND GEAR RATIO**

NOTE: When cold starting the lift truck, the direction of travel arrows are blue



and the speed is slow. This time delay, which varies according to the ambient temperature, serves to bring the gear box up to temperature.



- ⑤  **SPEED LIMIT REMINDER**
- ⑥ **NOT USED**
- ⑦  **STEERING SELECTION**
- ⑧  **CLOCK**
- ⑨  **DRIVING**
- ⑨  **WORK**
- Turn the navigation knob A to change the mode.
- ⑩  **EXTERNAL TEMPERATURE**





### 11 HOUR METER

- This screen is displayed for a few seconds when the ignition is switched on.



### SPEEDOMETER

- This screen is displayed in driving mode .



### HYDRAULIC FLOW RATE ADJUSTMENT

- This screen is displayed in working mode .









### POP UP

- Blue POP UP: information message.
- Grey POP UP: operating message.
- Orange POP UP: warning message.
- Red POP UP: fault warning message, consult your dealer.



### 12 ODOMETER

- Hold down and turn the navigation knob A to change the mode.

-  Total hour meter.
-  Partial hour meter.
-  Instantaneous fuel consumption.
-  Average fuel consumption.
-  Fuel autonomy.
-  Rev counter.



## 6 - DASHBOARD "VISION"

### 6A - INSTRUMENTS AND INDICATORS

### 6B - INFORMATION SCREEN



### 6A - INSTRUMENTS AND INDICATORS



MAIN BEAM INDICATOR LAMP



LOW BEAM INDICATOR LAMP



INDICATOR LIGHTS INDICATOR LAMP



ROTATING BEACON LAMP INDICATOR LAMP



PARKING BRAKE INDICATOR LAMP

This indicator lamp comes on when the parking brake is applied.

#### A - REV COUNTER

#### B - ENGINE WATER TEMPERATURE



If the indicator lamp  lights when the lift truck is running, this means that the coolant temperature is high. Stop the engine immediately and seek the cause of the cooling system malfunction.

#### C - FUEL LEVEL





Indicator lamp , indicates that you are in reserve and that your running time is limited.

#### D - LEVEL "DEF" (Diesel Exhaust Fluid)



The indicator lamp  lights if the level is below 15%.

#### E - FAULT WARNING LAMP DISPLAY ZONE

A maximum of five indicator lamps are displayed in the display zone. A red arrow  indicates a sixth fault. Beyond six faults, the  arrow flashes.



BATTERY CHARGE WARNING INDICATOR LAMP

If the lamp and the buzzer come on when the lift truck is running, stop the engine immediately and seek the cause (electric circuit, alternator belt, alternator, etc.).



STEERING SYSTEM OIL PRESSURE WARNING INDICATOR LAMP

If the lamp comes on when the lift truck is running, stop the engine immediately and determine the cause (possible leak, etc.).



WATER IN FUEL PRE-FILTER WARNING INDICATOR LAMP

This light will come on when there is water in the fuel pre-filter. Stop the lift truck and carry out the necessary repairs.

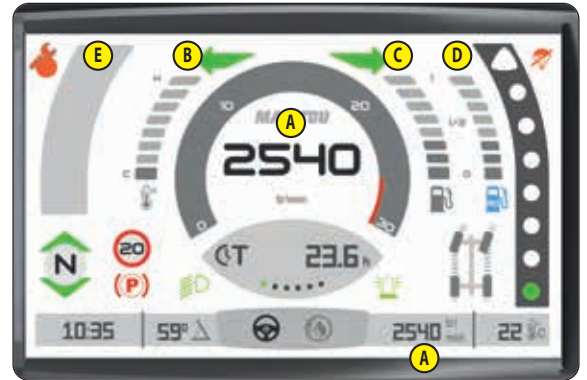



### **BRAKE FLUID LEVEL WARNING INDICATOR LAMP**

If the indicator lamp and buzzer come on, when the lift truck is running, stop the engine immediately and determine the cause (brake fluid level, possible leak, etc.). In the event of an abnormal drop in the level, consult your dealer.



### **ENGINE OIL PRESSURE WARNING INDICATOR LAMP**

If the indicator lamp comes on when the forklift truck is operating, stop the engine immediately and look for the cause (oil level in engine crankcase).

NOTE: After starting the engine, the indicator lamp remains lit for a few seconds then goes out when the correct engine oil pressure is reached. The full engine power is then available.



### **ENGINE PREHEAT INDICATOR LAMP**

Preheat is necessary. When the lift truck is switched on, the indicator lamp comes on for 2 seconds and goes off as soon as preheat is ended. Start the lift truck's engine.



### **GEAR BOX OIL PRESSURE WARNING INDICATOR LAMP**

The indicator lamp and buzzer come on when there is an abnormal drop in gear box pressure, in forward gear. Stop the engine and determine the cause (gear box oil level, possible leak, radiator, etc.).

NOTE: This indicator lamp operates in forward travel conditions only, and can be ignored when the lift truck is stopped with the engine running at min rpm.



### **GEAR BOX OIL TEMPERATURE WARNING INDICATOR LAMP**

The indicator lamp and buzzer come on when the gear box oil temperature is abnormally high. Stop the engine and determine the cause (gear box oil level, possible leak, radiator, etc.).



### **HYDRAULIC RETURN FILTER CLOGGING FAULT INDICATOR LAMP**

The indicator lamp and the buzzer come on when the hydraulic return oil filter cartridge is clogged. Stop the engine and carry out the necessary repairs (3 - MAINTENANCE: FILTER CARTRIDGES AND BELTS).



### **ENGINE WATER LEVEL WARNING INDICATOR LAMP**

If the indicator lamp and buzzer come on when the lift truck is running, stop the engine immediately and determine the cause (coolant level, possible leak, radiator, etc.).



### **ENGINE STOPPED WARNING INDICATOR LAMP**

If the indicator lamp lights up or flashes, when the lift truck is running, stop the engine immediately and consult your dealer.



### **AIR FILTER CLOGGING WARNING INDICATOR LAMP**

The lamp and the buzzer come on when the air filter cartridge is clogged up. Stop the lift truck and carry out the necessary repairs (3 - MAINTENANCE: FILTER CARTRIDGES AND BELTS).







### **ENGINE FAULT INDICATOR LAMP**

If the indicator lamp comes on or flashes while the lift truck is in operation, a diagnostic fault has been detected. The lift truck will operate in reduced mode. Consult your dealer without delay.



### FAULT INDICATOR LAMP "SCR" (selective catalytic reduction)

The indicator lamp lights up if the system efficiency or the quality of the diesel exhaust fluid is defective.

Flashing  indicator lamp +  + audible signal	- Diesel exhaust fluid level is below 10%.
 +  + audible signal	- Consult your dealer as soon as possible.









### CRYSTALLISATION OR SULPHURISATION LEVEL

If the indicator lamp flashes while the lift truck is running, perform a "STATIONARY LIFT TRUCK" EXHAUST SUBLIMATION (↖ 3 - MAINTENANCE: 1000H - PERIODIC MAINTENANCE - EVERY 1,000 HOURS OF SERVICE OR EVERY 2 YEARS).

NOTE: This indicator lamp also lights up every 1,000 hours so as to perform a "STATIONARY LIFT TRUCK" EXHAUST SUBLIMATION.

### 6B - INFORMATION SCREEN

- ①  **59°** BOOM ANGLE
- ②  **MAINTENANCE REQUIRED**
- ②  **MAINTENANCE REQUIRED + ERROR CODE NUMBER**
- ③  **HYDRAULIC MOVEMENT NEUTRALISATION**
- ③  **DISABLING "AGGRAVATING" HYDRAULIC MOVEMENT CUT-OFF**
- ④  **FORWARD/NEUTRAL/REVERSE GEAR AND GEAR RATIO**

NOTE: When cold starting the lift truck, the direction of travel arrows

are blue  and the speed is slow. This time delay, which varies according to the ambient temperature, serves to bring the gear box up to temperature.

- ⑤  **SPEED LIMIT REMINDER**

- ⑦  **STEERING SELECTION**

- ⑧  **10:35** CLOCK

- ⑨  **DRIVING**

 **WORK**

 **CAMERA (OPTION)**

- Turn the navigation knob A to change the mode.

- ⑩  **22** EXTERNAL TEMPERATURE

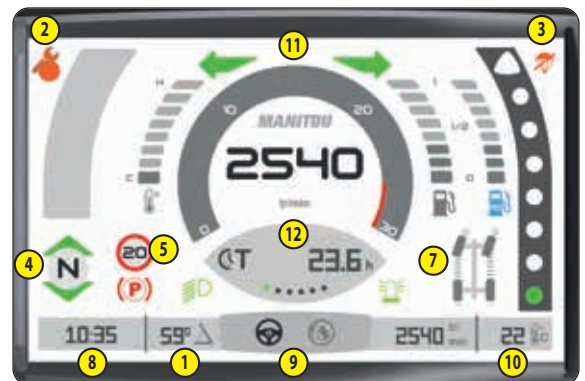



### 11 HOUR METER

- This screen is displayed for a few seconds when the ignition is switched on.



### SPEEDOMETER

- This screen is displayed in driving mode .



### HYDRAULIC FLOW RATE ADJUSTMENT

- This screen is displayed in working mode .









### POP UP

- Blue POP UP: information message.
- Grey POP UP: operating message.
- Orange POP UP: warning message.
- Red POP UP: fault warning message, consult your dealer.



### 12 ODOMETER

- Hold down and turn the navigation knob A to change the mode.

-  Total hour meter.
-  Partial hour meter.
-  Instantaneous fuel consumption.
-  Average fuel consumption.
-  Fuel autonomy.
-  Rev counter.



## 7 - LONGITUDINAL STABILITY LIMITER AND WARNING DEVICE

### ⚠ IMPORTANT ⚠

The operator must respect the lift truck's load chart, and the operating mode according to the attachment.

This device warns the operator of the lift truck's longitudinal stability limits. However, lateral stability can reduce the load chart in the upper part, and this reduction is not detected by the device.

Depending on the type of work required, the longitudinal stability limiter and warning device allows the operator to operate the lift truck in complete safety.

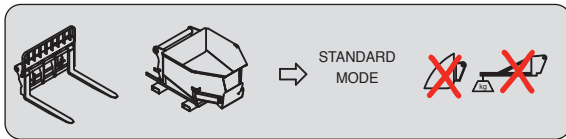
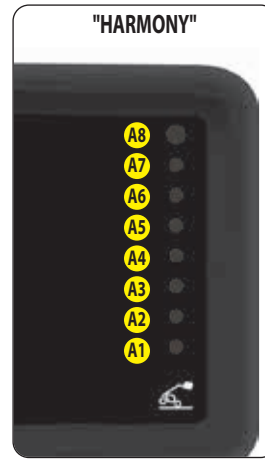

### "HANDLING" MODE

#### USE ON FORKS

- By default, the device is in "HANDLING MODE" each time the lift truck is started.
- Protection against tilting forwards during aggravating movements is guaranteed, except when the telescope is retracted.

STATUS OF THE DEVICE			
HALTED	SLOW SPEED 1 to 5 km/h	SPEED > 5 km/h	TELESCOPE(S) RETRACTED
A4-A5 : Very slow intermittent sound alarm. A6 : Slow intermittent sound alarm. A7 : Fast intermittent sound alarm. A8 : Very fast intermittent sound alarm.	A7 : Fast intermittent sound alarm. A8 : Very fast intermittent sound alarm.	- No sound alarm.	- No sound alarm. - Indicator light  on.

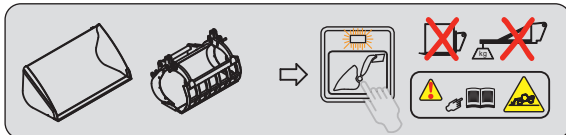

### "BUCKET" MODE

#### USE WITH BUCKET

- Place the lift truck in the transport position.
- Press the button, "BUCKET" MODE is confirmed by an audible signal and the lighting of the light.
- Press this button again or switch off the ignition with the ignition key to return to "HANDLING" MODE.
- Protection against tilting forwards during aggravating movements is guaranteed, except when the telescope is retracted.

STATUS OF THE DEVICE			
HALTED	SLOW SPEED 1 to 5 km/h	SPEED > 5 km/h	TELESCOPE(S) RETRACTED
- The "BUCKET" mode deactivates after a few seconds if the lift truck remains stationary.	A6 : An audible signal upon passing into the red zone. - The hydraulic movements are adapted.	No sound alarm. - The hydraulic movements are adapted.	- No sound alarm. - Indicator light  on.

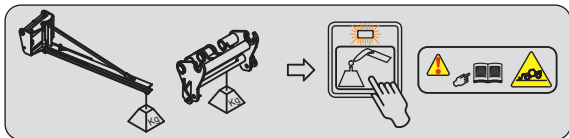

## "SUSPENDED LOAD" MODE

USE WITH LIFTING DEVICE (offering a higher margin of safety)

- Place the lift truck in the transport position.
- Press the  button, the "SUSPENDED LOAD" MODE is confirmed by an audible signal and the lighting of the indicator lamp. Hydraulic inclination movements are neutralised, as well as the lifting movement when the longitudinal limit is reached (indicator lamp A8 lit).
- Press this button again or switch off the ignition with the ignition key to return to "HANDLING" MODE.
- Protection against tilting forwards during aggravating movements is guaranteed, except when the telescope is retracted.

STATUS OF THE DEVICE			
HALTED	SLOW SPEED 1 to 5 km/h	SPEED > 5 km/h	TELESCOPE(S) RETRACTED
	A4-A5 : Very slow intermittent sound alarm. A6 : Slow intermittent sound alarm. A7 : Fast intermittent sound alarm. A8 : Very fast intermittent sound alarm.		-No sound alarm. -Indicator light  on.

### A - VISUAL ALARMS

- A1 - A2 - A3: There is a significant reserve of longitudinal stability.
- A4 - A5: The lift truck is approaching the limit of longitudinal stability, move with care.
- A6: The lift truck is close to the longitudinal stability limit. Manoeuvre with care.
- A7: The lift truck is very close to the longitudinal stability limit. Manoeuvre with extreme caution.
- A8: The lift truck is at the authorised limit of longitudinal stability.

### B - HYDRAULIC MOVEMENT CUT-OFF

"HANDLING" MODE

- A8: All "AGGRAVATING" hydraulic movements are cut off. Only perform de-aggravating hydraulic movements in the following order: retract and raise the boom.

"BUCKET" MODE

- A8: The boom lowering and extension movements are cut off, the other movements remain available.

"SUSPENDED LOAD" MODE



- A8: All "AGGRAVATING" and boom raising hydraulic movements are cut off. Only the boom retraction hydraulic movement is available.

### C - DISABLING "AGGRAVATING" HYDRAULIC MOVEMENT CUT-OFF

**⚠ IMPORTANT ⚠**

*Remain very vigilant during this operation. The only information available to the operator is the lift truck's dynamic stability.*

In certain cases, in order to get out of a difficult situation, the operator can bypass this safety system. The  button temporarily disables the cutting-off of "AGGRAVATING" hydraulic movements.

- Hold down the  button, the indicator lamp will light (60 second time delay), and the  pictogram will appear on the information screen. Simultaneously perform the necessary "AGGRAVATING" hydraulic movement with extreme care

### D - STRAIN GAUGE

**⚠ IMPORTANT ⚠**

*Disassembly or calibration of the strain gauge is prohibited, this must only be done by specially trained personnel, consult your dealer.*

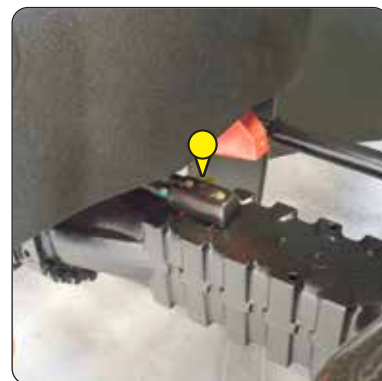

## 8 - INFORMATION SCREEN CONTROL CONSOLE

### A - VALIDATION AND CONFIRMATION BUTTON

### B - PREFERENCES MENU

- Press the button to display the "PREFERENCES" menu.
- Turn knob A to navigate through the menus and sub-menus.
- Press knob A to confirm.

SYSTEM	>	DATE AND TIME	
	>	LANGUAGES	
	>	UNITS	
	>	SCREEN	
	>	POP-UP	> RESET
	>	DIGICODE (OPTION)	
TRANSMISSION	>	CAMERA (OPTION)	
	>	ECO MODE (OPTION)	
	>	MANUAL ACCELERATOR (OPTION)	
HYDRAULICS	>	TRAILER BRAKE TEST	(double line trailer brake)
	>	STABILITY TEST	
	>	STABILITY REBALANCING	
	>	HYDRAULIC MODE	> DYNAMIC > COMFORT (Increased flow rate on transmission) > DYNAMIC PLUS (Increased flow rate on hydraulics)
EXPERT	>	EASY CONNECT SYSTEM	
	>	STABILITY CALIBRATION	(menu reserved for your dealer)
	>	BOOM ANGLE CALIBRATION	(menu reserved for your dealer)
	>	INCHING PEDAL CALIBRATION	(menu reserved for your dealer)
	>	CARRIAGE ANGLE CALIBRATION	(menu reserved for your dealer)
	>	DISTRIBUTOR CALIBRATION	(menu reserved for your dealer)



### C - INFORMATION MENU

- Press the button to display the "INFORMATION" menu.
- Turn knob A to navigate through the menus and sub-menus.
- Press knob A to confirm.

TROUBLESHOOTING	>	FAULT
MAINTENANCE	>	MAINTENANCE RESET
GENERAL	>	IDENTIFICATION
	>	SOFTWARE VERSION

### D - BACK

- Press the button to return to the previous screen.



#### HYDRAULIC MOVEMENT NEUTRALISATION

When driving on the road, it is highly recommended (mandatory in Germany) that you cut off all the hydraulic movements. The indicator lamp will light and the  pictogram will be displayed on the screen when it is in use.



#### ROTATING BEACON LIGHT

The indicator lamp will light when it is in use.



#### HAZARD WARNING LIGHTS

## 9 - PUSH BUTTON PANEL

### PUSH BUTTON FUNCTIONS

- Red button: Safety.
- Orange button: Transmission / Engine.
- Blue button: Hydraulics.
- Black button: Other.

### PUSH BUTTON DIAGNOSTICS

- If all buttons are unlit, there is a power supply problem. Contact your dealer.
- If all buttons are flashing, there is a connection problem. Contact your dealer.

#### **DISABLING "AGGRAVATING" HYDRAULIC MOVEMENT CUT-OFF**

< LONGITUDINAL STABILITY LIMITER AND WARNING DEVICE

#### **OPTION**

#### **"COMFORT TRANSMISSION" MODE**

- Takes longer to reach top speed.
- Same traction force.

#### **"DYNAMIC TRANSMISSION" MODE**

- Transmission more responsive.

#### **HEAT ENGINE SPEED MEMORISATION (OPTION)**

< DESCRIPTION AND USE OF THE OPTIONS

#### **USE OF FRONT OR REAR ATTACHMENT CIRCUIT (OPTION)**

< DESCRIPTION AND USE OF THE OPTIONS

#### **"BUCKET" MODE**

< LONGITUDINAL STABILITY LIMITER AND WARNING DEVICE

#### **"SUSPENDED LOAD" MODE**

< LONGITUDINAL STABILITY LIMITER AND WARNING DEVICE

#### **BOOM SUSPENSION (OPTION)**

< DESCRIPTION AND USE OF THE OPTIONS

#### **FORCED BOOM SUSPENSION (OPTION)**

< DESCRIPTION AND USE OF THE OPTIONS

#### **ATTACHMENT CIRCUIT FLOW RATE LIMITER (OPTION)**

< DESCRIPTION AND USE OF THE OPTIONS

#### **ATTACHMENT CIRCUIT CONTINUE FLOW (OPTION)**

< DESCRIPTION AND USE OF THE OPTIONS

#### **TILT CIRCUIT LOCKING (OPTION)**

- Press the button to shut off the tilt circuit hydraulic movements. The indicator lamp will show it is in use.

#### **ATTACHMENT CIRCUIT LOCKING (OPTION)**

- Press the button to shut off the attachment circuit hydraulic movements. The indicator lamp will show it is in use.





### AUTOMATIC SELF-CLEANING FAN

Cleans the radiator core and the grille of the engine cover by reversing the air flow.

#### **⚠ IMPORTANT ⚠**

*The self-cleaning fan is operational from an engine water temperature of 40 °C.*

*When in use, beware of the risk of projection into the eyes.*

- The indicator light is on, the fan operates in self-cleaning mode for a few seconds once every 3 minutes.



### FORCED SELF-CLEANING FAN

- Press the button to force a cleaning cycle. The indicator lamp will light when it is in use.
- Wait 3 minutes between requests.



### SEMI-AUTOMATIC WHEEL ALIGNMENT (OPTION)

◀ DESCRIPTION AND USE OF THE OPTIONS



### EXHAUST SUBLIMATION

◀ 3 - MAINTENANCE: 1000H - PERIODIC SERVICE - EVERY 1,000 HOURS OF SERVICE OR 2 YEARS

## 10 - SWITCHES



### BOOM HEAD WORKLIGHTS (OPTION)



### FRONT WORKLIGHTS (OPTION)



### REAR WORKLIGHTS (OPTION)



### SIDE WINDSCREEN WIPER (OPTION)



### SIDE WORKLIGHTS (OPTION)



### REAR FOG LIGHTS (OPTION)



### BOOM HEAD ELECTROVALVE (OPTION)

OR

### "JCB SINGLE CARRIAGE" ATTACHMENT HYDRAULIC LOCKING (OPTION)

◀ DESCRIPTION AND USE OF THE OPTIONS



### BOOM ELECTRICAL PREDISPOSITION (OPTION)

◀ DESCRIPTION AND USE OF THE OPTIONS



### MAIN RIGHT-HAND REAR-VIEW MIRROR DEFROST (OPTION)



### BLUE WORKLIGHTS (OPTION)



## 11 - LIGHTING, HORN AND INDICATOR SWITCH

The switch controls the visual and sound alarms.

- A - All lights are off, the indicator lights do not flash.
- B - The right hand indicator lights flash.
- C - The left hand indicator lights flash.
- D - Sidelights and rear lights on.
- E - The dipped headlights and the rear lights are on.
- F - The main beam headlights and the rear lights are on.
- G - Headlight signalling.

Pressing the end of the switch sounds the horn.

NOTE: Positions D - E - F - G can be used without switching on the ignition.

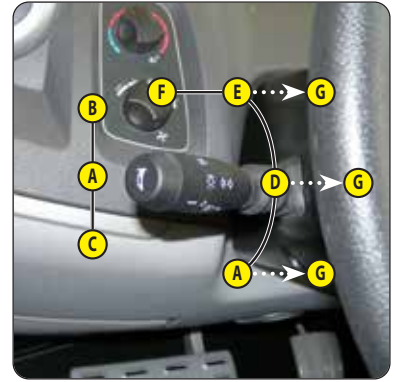

## 12 - FRONT AND REAR WINDSCREEN WIPER SWITCH

FRONT WINDSCREEN WIPER

- A - Front windscreen wiper off.
- B - Front windscreen wiper low speed setting.
- C - Front windscreen wiper low speed setting.
- D - Front windscreen wiper intermittent operation.
- E - Front windscreen wiper pulse driven.

REAR WINDSCREEN WIPER

- F - Rear windscreen wiper off.
- G - Rear windscreen wiper on.
- H - Rear windscreen washer, pulse driven (not used).

NOTE: These functions will only work when the ignition is switched on.

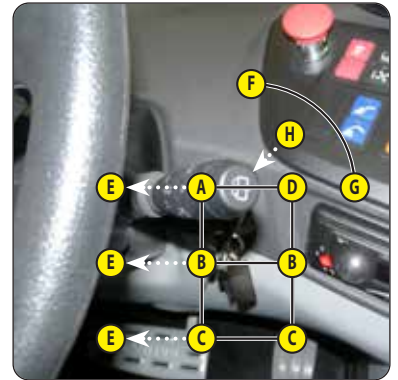

## 13 - STEERING SELECTION

### ⚠ IMPORTANT ⚠

*Before selecting one of the three steering possibilities, align the 4 wheels in relation to the lift truck axis.  
Never change the steering mode whilst driving.*



The green indicator lamps  light on the information screen to indicate the alignment of the wheels relative to the lift truck.

- When driving on the road, block the selector switch with the lock 1.



### A - STEERING SELECTION SWITCH

- A1 - Front steering wheels (road mode).
- A2 - Front and rear steering wheels in opposite directions (short steering).
- A3 - Front and rear steering drive wheels in the same direction (crab steering).

CHECKING WHEEL ALIGNMENT

### ⚠ IMPORTANT ⚠

*Check the alignment of the front and rear wheels each time the lift truck is started.  
Regularly check the alignment of the wheels when using the lift truck.  
The wheels must be aligned and the lift truck must be in front steering wheels mode when used on public roads.  
A green light comes on on the dashboard when the wheels are aligned.  
Contact your dealer if you have any questions.*

- Select "short steering" (position A2).
- Turn the steering wheel and bring the rear wheels into alignment until the  indicator lamps light on the rear wheels.
- Select "road driving" (position A1).
- Turn the steering wheel and bring the rear wheels into alignment until the  indicator lamps light on the front wheels.





**MINIFUSE**

F51	5A	Hydrostatic transmission ECU power supply + info 12V AU/ transmission ECU.
F52		Free.
F53		Free.
F54		Free.
F55		Free.
F56	5A	Customer anti-start (OPTION).
F57	7.5A	Car radio.
F58	15A	Semi-automatic wheel alignment (OPTION).
F59	15A	Hazard warning lights (K4).
F60	20A	Lighting, horn and indicator switch.
F61	7.5A	Left indicator lights.
F62	7.5A	Right indicator lights.
F63	15A	Dipped beam headlights.
F64	15A	Main beam headlights.
F65	7.5A	Left sidelights.
F66	7.5A	Right sidelights.
F67	7.5A	Rear fog lights.
F68		Free.
F69		Free.
F70		Free.

**MAXIFUSE**

F101	20A	Hydrostatic transmission ECU power supply.
F102	30A	Fan/heating (K3).
F103	60A	Ignition switch.
F104	50A	Module 3 fuses (F41 à F60).
F105	30A	Air conditioning (OPTION).
F106		Free.

**RELAYS**

K1	Front windscreen wiper speed 1.
K2	Dashboard power supply.
K3	Fan/heating.
K4	Flashing unit supply
K5	Transmission neutral.
K6	Rotating beacon light.
K11	Transmission cut-off.
K12	Reversing lights and reverse warning indicator.
K13	Forward gear.
K14	Trailer brake test.
K15	Free.
K16	Reverse gear.
K21	Flashing unit.
K22	Hazard warning lights.

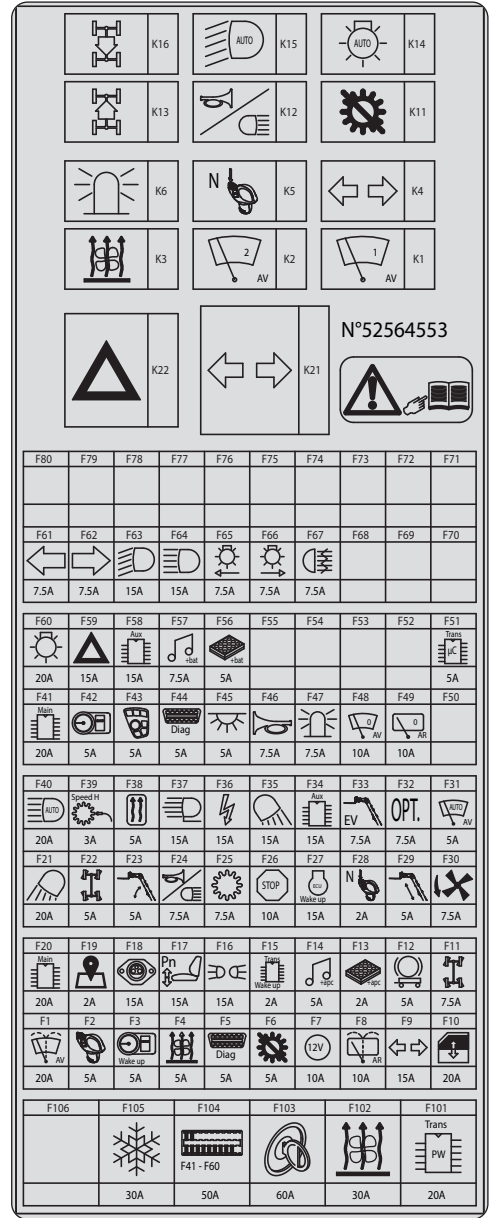



## 19 - GEAR SELECTOR

The gear can be selected by means of the (-) and (+) buttons. The engaged gear is indicated on the information screen .

- GEAR 1: Recommended for work that calls for more traction or thrust force at low speed (e.g. silaging, earthwork, manure, towing on steep slope, etc.).
- GEAR 2: Recommended for all other work at low or high speed, making the lift truck versatile (e.g. handling, loading, livestock feeding, towing on the flat or a slight slope, driving on roads, etc.).



## 20 - PARKING BRAKE LEVER

To prevent accidental loosening or release, the lever is fitted with safety locking.

- Press button 1 to disable the safety lock.
- Pull the lever (position A) to apply the parking brake.
- Lower the lever (position B) to release the parking brake.

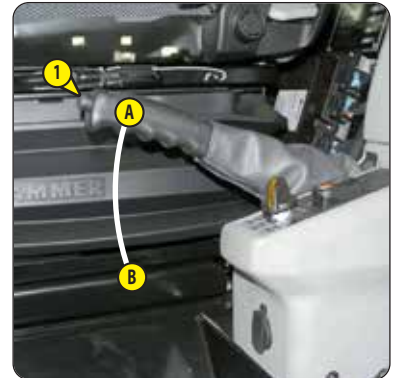

## 21 - FORWARD/NEUTRAL/REVERSE GEAR SELECTION

When changing the direction of travel, the lift truck should be travelling at slow speed and not accelerating.

- FORWARD: Push the switch forward (position A).
- REVERSE: Push the switch backward (position B). Reversing lights and an acoustic reversing alarm indicate that the lift truck is travelling in reverse.
- NEUTRAL: The switch must be in the neutral position (position C) to start the lift truck.

NOTE: Reversing sound alarm (OPTIONAL or STANDARD).

### SAFETY FOR MOVING THE LIFT TRUCK

The operator must observe the following sequence to move the truck forwards or backwards:

- 1 - sit down correctly in the driver's seat,
- 2 - release the hand brake,
- 3 - engage forward or reverse.



NOTE: The alternate display of the forward or reverse section arrow  on the information screen requires the selector to be set to neutral.

To stop the forklift truck without switching off the ignition, the following sequence must be followed:

- 1 - Set the forward/reverse selector to neutral,
- 2 - Apply the parking brake,
- 3 - Get out of the lift truck.

NOTE: A discontinuous audible signal and a message on the screen will inform the driver if he has left the driver's cab without applying the parking brake.

## 22 - HYDRAULIC CONTROLS

### ⚠ IMPORTANT ⚠

**Do not attempt to alter the hydraulic system pressure by interfering with the pressure regulating valve. In the event of suspected malfunction, contact your dealer. ANY ALTERATION MAY RENDER THE WARRANTY NULL AND VOID AND INCURS LIABILITY IN THE EVENT OF AN ACCIDENT.**

**Use the hydraulic controls gently without jerking, to avoid incidents caused by shaking the lift truck.**

NOTE: If necessary, operate the steering to reset the hydraulic control steering accumulator.

NOTE: When driving on the road, it is highly recommended (mandatory in Germany) that you cut off all the hydraulic movements (⏏ PUSH BUTTON PANEL).

### HYDRAULIC CONTROLS ACTIVATION

To avoid inadvertent operation of the hydraulic lifting, tilting, telescoping and attachment controls, a safety device is added to the lift truck (SECOND FIT).

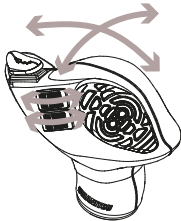
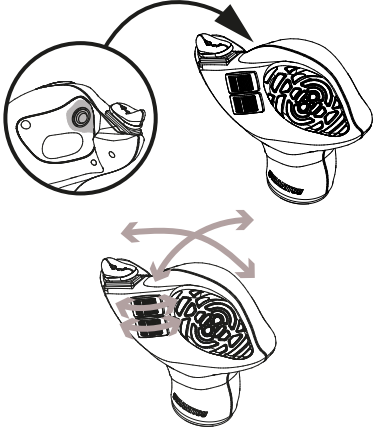
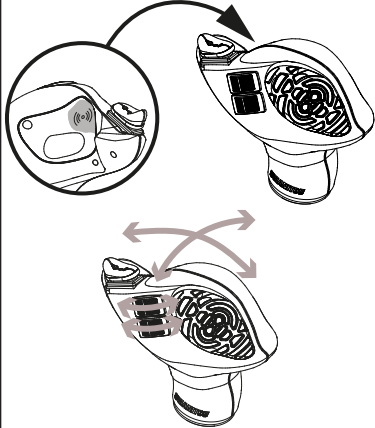
FIRST FIT: NO HYDRAULIC CONTROLS ACTIVATION			
	-Place your hand on the lever and perform the hydraulic movement.		
SECOND FIT: HYDRAULIC CONTROLS ACTIVATION			
USING THE BUTTON		USING THE CAPACITIVE SENSOR	
	-Place your hand on the lever, activate the hydraulic controls by pressing the button and perform the hydraulic movement.		-Place your hand on the lever, activate the hydraulic controls by contact on the capacitive sensor and perform the hydraulic movement.
- Hydraulic controls activation is maintained on a timer while the lift truck is being used. - If necessary, reactivate the hydraulic controls.			

- A - Lifting and tilting control lever.
- B - Telescoping control button.
- C - Attachment control button.
- D - Boom head electrovalve OPTION control button.

### LIFTING THE LOAD

- Lever A backwards for lifting.
- Lever A forwards for lowering.

### TILTING THE CARRIAGE

- Lever A to the left to tilt backward.
- Lever A to the right to tilt forward.

### TELESCOPING

- Button B forwards for extending.
- Button B backwards for retracting.

### ATTACHMENT

- Button C forwards or backwards.

### BOOM ELECTRICAL PREDISPOSITION (OPTION)

### BOOM HEAD ELECTROVALVE (OPTION)

- Button D (⏏ DESCRIPTION AND USE OF THE OPTIONS).

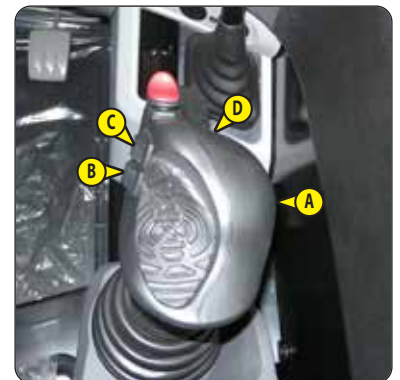

## 23 - FUNCTION FILES

---

These files contain the description of the hydraulic controls and the load charts for the attachments used on the lift truck.



## 24 - LEVEL INDICATOR

---

Enables the operator to check that the lift truck is in the horizontal position.



## 25 - HEATER CONTROL

---

### A - FAN CONTROL

This 4-speed control allows the air to be ventilated through the air vents.

### B - TEMPERATURE CONTROL

Adjusts the temperature inside the cab.

- B1 - The fan pumps in the air at ambient temperature.
- B2 - The fan pumps in warm air.

The intermediate positions allow the temperature to be adjusted.



## 26 - AIR CONDITIONING CONTROLS (AIR CONDITIONING OPTION)

### ⚠ IMPORTANT ⚠

*The air conditioning only works if the lift truck has been started.*

*When using your air conditioning, it is essential to work with the cab closed.*

*In winter: So as to ensure that the air conditioning unit is correctly operated and completely efficient, start up the compressor once a week, even for a short period of time, in order to lubricate the internal seals.*

*In cold weather: Warm the engine before switching on the compressor, in order to allow the coolant that has collected in the liquid state at the lowest point of the compressor's circuit to turn into gas under the effect of the heat given off by the engine, as the compressor is liable to be damaged by coolant in the liquid state.*

*If your air conditioning does not seem to be working correctly, have it examined by your dealer.*

*Never try to repair any faults yourself.*

### A - FAN CONTROL

This 4-speed control allows the air to be ventilated through the air vents.

### B - TEMPERATURE CONTROL

Adjusts the temperature inside the cab.

- B1 - The fan pumps in cold air.
- B2 - The fan pumps in warm air.

The intermediate positions allow the temperature to be adjusted.

### C - AIR CONDITIONING CONTROL

This control with a pilot light allows the air conditioning unit to be switched on.

#### HEATING MODE

- The controls must be adjusted in the following way:
  - C - Control with pilot light off.
  - B - At the desired temperature.
  - A - At the desired speed: 1, 2 or 3.

#### AIR CONDITIONING MODE

- The controls must be adjusted in the following way:
  - C - Control with pilot light on.
  - B - At the desired temperature.
  - A - At the desired speed: 1, 2 or 3.

#### DEMISTING MODE

- The controls must be adjusted in the following way:
  - C - Control with pilot light on.
  - B - At the desired temperature.
  - A - At speed 2 or 3.
- For optimum effectiveness, close the heating ventilators.



## 27 - WINDSCREEN DEMISTER VENTS

For optimum effectiveness, close the heating ventilators.

## 28 - HEATING VENTS

These swivelling heating vents, which can be shut off, allow you to direct and adjust the flow inside the cab.

## 29 - STEERING WHEEL ADJUSTMENT LEVER

This handle enables the angle and height of the steering wheel to be adjusted.

- Pull the knob backwards.
- Adjust the steering wheel to the desired position.
- Push the knob back to lock the steering wheel in position.



## 30 - DOOR OPENING AND CLOSING HANDLE

Two keys are provided with the lift truck to enable the cabin to be locked.

- Press the door handle trigger to open the door.
- Pull on the handle to close the door.



## 31 - WINDOW WINDER

## 32 - REAR WINDOW STAY

### EMERGENCY EXIT

Use the rear window as an emergency exit, in the event that it is impossible to leave the cab by the door or by opening the windscreen.

- Remove the pin to fully open the rear window.



## 33 - STORAGE NET

Ensure that the operator's manual is in its place in the storage net.

## 34 - STORAGE



**35 - SUN VISOR**

---

**36 - ROOF LIGHT**

---

**37 - HOOK**

---

**38 - INSIDE REAR-VIEW MIRROR**

---

**39 - TELEPHONE HOLDER**

---

**40 - CIGARETTE LIGHTER**

---

For 12 V appliance and max. amperage 10A.

**41 - USB RECHARGING SOCKET**

---

**42 - ARMREST AND STORAGE**

---

Lift the armrest to access the storage.

**43 - EMERGENCY EXIT**

---

**EMERGENCY HAMMER**

Use the emergency hammer to break one of the windows in the event that it is impossible to exit the cab by the door or by opening the rear window.



## 44 - BATTERY

## 45 - BATTERY CUT-OFF

For quickly disconnecting the battery when working on the electric circuit or when soldering, for example.

### ⚠ IMPORTANT ⚠

*Switch off the ignition with the key, wait 30 seconds, then operate the battery cut-off.*

*Wait 5 minutes before disconnecting the battery, this is required in order to purge the Diesel Exhaust Fluid (DEF) system*



## 46 - FRONT HEADLIGHTS

- A - Front left-hand indicator light.
- B - Front left-hand dipped headlight.
- C - Front left-hand headlight.
- D - Front left-hand sidelight.
- E - Front right-hand indicator light.
- F - Front right-hand dipped headlight.
- G - Front right-hand headlight.
- H - Right front sidelight.

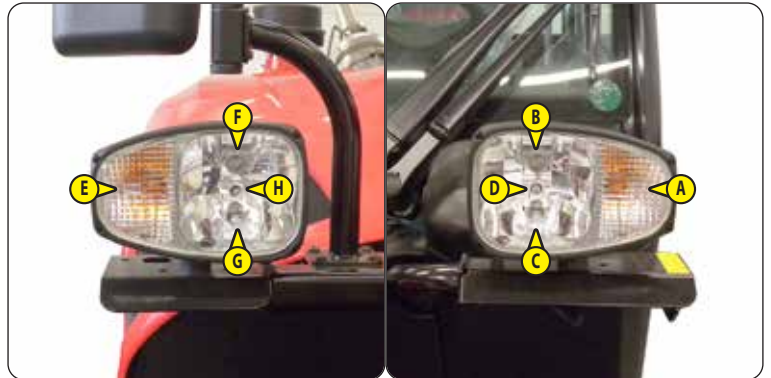

## 47 - REAR LIGHTS

- A - Rear left-hand indicator light.
- B - Rear left-hand stop light.
- C - Rear left hand headlight.
- D - Rear fog light.
- E - Rear reversing light.
- F - Rear right hand headlight.
- G - Rear right-hand stop light.
- H - Rear right-hand indicator light.

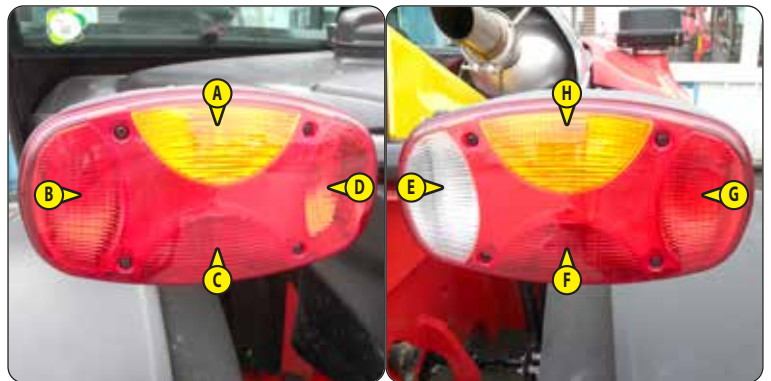

## 48 - ROTATING BEACON LIGHT

The magnetic rotating beacon light must be clearly visible on the roof of the cab and plugged into socket 1.

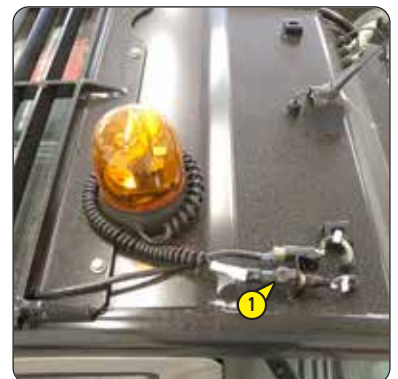

## 49 - BOOM SAFETY WEDGE

### ⚠ IMPORTANT ⚠

*Only use the wedge supplied with the lift truck.*

The lift truck is equipped with a boom safety wedge which must be installed on the rod of the lifting cylinder when working beneath the boom (⇐ 1 - OPERATING AND SAFETY INSTRUCTIONS).



## 50 - FUEL TANK

As far as possible, keep the fuel tank well filled in order to minimise condensation due to the atmospheric conditions.

### ⚠ IMPORTANT ⚠

*Never smoke or approach with a flame during filling operations or when the tank is open.*

*Never refill while engine is running.*

- If necessary, add diesel (☞ 3 - MAINTENANCE: LUBRICANTS AND FUEL).
- Remove the cap 1.
- Fill the fuel tank with clean diesel filtered through the filler port 2.
- Refit the cap.
- Visually check that there is no leakage in the tank and pipes.

NOTE: A locking tank cap is available as an OPTION.



## 51 - TANK "DEF" (Diesel Exhaust Fluid)

### ⚠ IMPORTANT ⚠

*Diesel exhaust fluid is corrosive: protect the bodywork and wear personal protective equipment (gloves and goggles).*

*The Diesel Exhaust Fluid level is important. Operating with a low or empty DEF tank level may affect engine performance.*

- If necessary, add diesel exhaust fluid (☞ 3 - MAINTENANCE: LUBRICANTS AND FUEL).
- Remove the cap 1.
- Slowly fill the tank to the bottom of the filler neck.
- Always maintain a good level to avoid alternation of the product.
- Refit the cap.

NOTE: A locking tank cap is available as an OPTION.



### QUALITY "DEF" (Diesel Exhaust Fluid)

The diesel exhaust fluid quality can be measured using a refractometer. The diesel exhaust fluid must comply with standard ISO 22241-1 with a urea concentration of 32.5%.

Refractometer (MANITOU part number: 959709)

### STORAGE "DEF" (Diesel Exhaust Fluid)

Up to 4 months without using the lift truck, check the quality of the diesel exhaust fluid with a refractometer.

Beyond 4 months, replace the diesel exhaust fluid. Empty and rinse the tank DEF.

NOTE: For a prolonged shutdown of the lift truck, ☞ 1 - OPERATING AND SAFETY INSTRUCTIONS: LONG-TERM LIFT TRUCK SHUTDOWN.

## TOWING DEVICE

1 - FRAME-MOUNTED FRONT TOWING HOOK .....	2-85
2 - CLEVIS HITCH .....	2-85
3 - AUTOMATIC CLEVIS HITCH (OPTION) .....	2-85
4 - CLEVIS HITCH ON COUPLING LADDER (OPTION) .....	2-86
5 - AUTOMATIC TOWING YOKE ON COUPLING LADDER (OPTION) .....	2-86
6 - BALL HITCH ON COUPLING LADDER (OPTION) .....	2-87
7 - FIXED PIN ON COUPLING LADDER (OPTION) .....	2-87
8 - HYDRAULIC TOWING HOOK (OPTION) .....	2-88
9 - REAR ELECTRIC SOCKET .....	2-88
10 - HYDRAULIC TRAILER BRAKE .....	2-89
11 - PNEUMATIC TRAILER BRAKE (OPTION) .....	2-89

### **⚠ IMPORTANT ⚠**

*Do not tow a trailer or an attachment that is not in perfect working condition.*

*Using a trailer in poor condition may affect the lift truck's steering and braking, and hence the safety of the assembly.*

*If a third party helps in coupling or uncoupling the trailer, this person must be permanently visible to the driver and wait until the lift truck has stopped, the handbrake is on and the I.C. engine is switched off before performing the operation.*

Located at the rear of the lift truck, this device is used to couple a trailer. Capacity is limited for each lift truck by the authorised gross vehicle weight (AGVW), tractive effort and maximum vertical force on the coupling point. This information is given on the manufacturer's plate fixed to each lift truck (➤ IDENTIFICATION OF THE LIFT TRUCK).

- To use a trailer, see current regulations in your country (maximum running speed, braking, maximum weight of trailer, etc.).
- Verify the trailer's condition before using it (tyre condition and pressures, electrical connection, hydraulic hose, brake system...).

## 1 - FRAME-MOUNTED FRONT TOWING HOOK

### ⚠ IMPORTANT ⚠

*This pin is only intended for towing or winching the lift truck in the event of a breakdown.*

*⚠ 3 - MAINTENANCE: OCCASIONAL OPERATION for towing or winching the lift truck.*



## 2 - CLEVIS HITCH

### ⚠ IMPORTANT ⚠

*Be careful not to get your fingers caught or crushed during this operation.*

*Do not forget to put the cotter pin back in place.*

*When uncoupling, make sure that the trailer is supported independently.*

### COUPLING AND UNCOUPLING THE TRAILER

- To couple the trailer, position the lift truck as close as possible to the trailer ring.
- Apply the handbrake on and switch off the engine.
- Remove the pin 1, lift the towing pin 2 and place or remove the trailer ring.

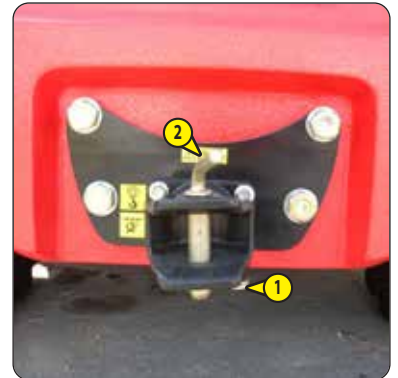

## 3 - AUTOMATIC CLEVIS HITCH (OPTION)

### ⚠ IMPORTANT ⚠

*When uncoupling, make sure that the trailer is supported independently.*

### COUPLING THE TRAILER

- Remove the automatic towing pin using lever 1.
- Move the lift truck backwards so that the trailer ring slots into the automatic hook.

NOTE: The pin closes automatically when the trailer ring touches the back of the clevis. The pin can be lowered by hand using lever 1.

### UNCOUPLING THE TRAILER

- Lift the pin using lever 1 to uncouple the trailer.



#### 4 - CLEVIS HITCH ON COUPLING LADDER (OPTION)

*Be careful not to get your fingers caught or crushed during this operation.  
When uncoupling, make sure that the trailer is supported independently.*

- Position the lift truck as close as possible to the trailer ring.
- Apply the handbrake on and switch off the engine.

##### ADJUSTING THE TOWING CLEVIS

- Lift the handle 1 and pivot it upwards to release the pins 2 on either side of the ladder.
- Support the clevis and adjust it according to the height of the trailer ring.
- Pivot the handle 1 downwards to engage the 2 pins in the ladder and release the handle.

##### COUPLING AND UNCOUPLING THE TRAILER

- Remove the towing pin 3 and place or remove the trailer ring.
- Refit and lock towing pin 3 in position.

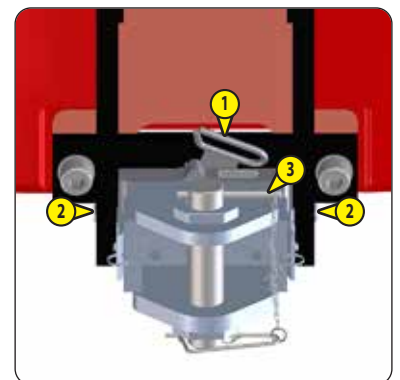
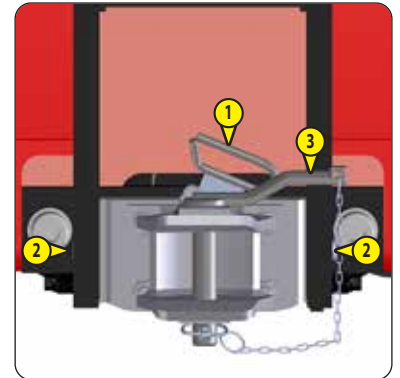

#### 5 - AUTOMATIC TOWING YOKE ON COUPLING LADDER (OPTION)

**⚠ IMPORTANT ⚠**

*Be careful not to get your fingers caught or crushed during this operation.  
When uncoupling, make sure that the trailer is supported independently.*

- Position the lift truck as close as possible to the trailer ring.

##### ADJUSTING THE TOWING CLEVIS

- Lift the handle 1 and pivot it upwards to release the pins 2 on either side of the ladder.
- Support the clevis and adjust it according to the height of the trailer ring.
- Pivot the handle 1 downwards to engage the 2 pins in the ladder and release the handle.

##### COUPLING THE TRAILER

- Remove the automatic towing pin using lever 3.
- Move the lift truck backwards so that the trailer ring slots into the automatic hook.

NOTE: The pin closes automatically when the trailer ring touches the back of the clevis. The pin can be lowered by hand using lever 3.

##### UNCOUPLING THE TRAILER

- Lift the pin using lever 3 to uncouple the trailer.

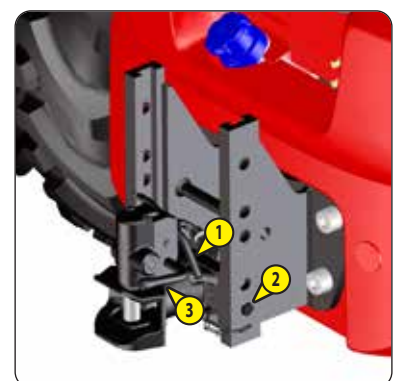

## 6 - BALL HITCH ON COUPLING LADDER (OPTION)

### ⚠ IMPORTANT ⚠

*Be careful not to get your fingers caught or crushed during this operation.  
When uncoupling, make sure that the trailer is supported independently.*

- Position the lift truck as close as possible to the trailer ring.

### ADJUSTING THE TOWING CLEVIS

- Lift the handle 1 and pivot it upwards to release the pins 2 on either side of the ladder.
- Support the clevis and adjust it according to the height of the trailer ring.
- Pivot the handle 1 downwards to engage the 2 pins in the ladder and release the handle.

### COUPLING AND UNCOUPLING THE TRAILER

- Remove the cotter pin 3 and the locking pin 4.
- Lift the hitch bolt 5.
- Place or remove the coupling head of the trailer on the ball hitch.
- Refit the hitch lock 5, the locking pin 4 and the cotter pin 3.

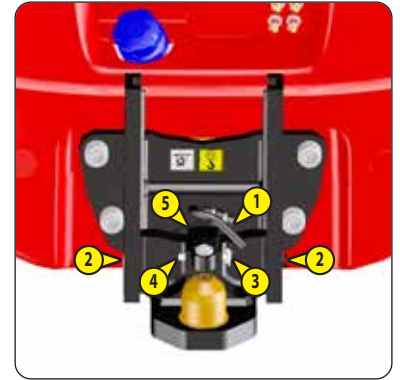

## 7 - FIXED PIN ON COUPLING LADDER (OPTION)

### ⚠ IMPORTANT ⚠

*Be careful not to get your fingers caught or crushed during this operation.  
When uncoupling, make sure that the trailer is supported independently.*

- Position the lift truck as close as possible to the trailer ring.

### ADJUSTING THE TOWING CLEVIS

- Lift the handle 1 and pivot it upwards to release the pins 2 on either side of the ladder.
- Support the clevis and adjust it according to the height of the trailer ring.
- Pivot the handle 1 downwards to engage the 2 pins in the ladder and release the handle.

### COUPLING AND UNCOUPLING THE TRAILER

- Remove the cotter pin 3 and the locking pin 4.
- Lift the hitch bolt 5.
- Place or remove the coupling head of the trailer on the fixed pin.
- Refit the hitch lock 5, the locking pin 4 and the cotter pin 3.

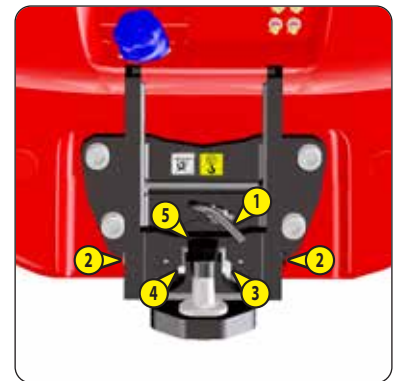

## 8 - HYDRAULIC TOWING HOOK (OPTION)

### ⚠ IMPORTANT ⚠

*Never use the tow hook to raise the rear of the lift truck (when changing the rear wheel for example).  
When uncoupling, make sure that the trailer is supported independently.*

- Select the rear attachment hydraulic line .
- Push switch 1 forwards to release the locking pin securing the hook 2.
- Pull on the knob 3 and hold in position.
- Push switch 1 backwards to lower the towing hook.
- Release knob 3.
- Couple or uncouple the trailer.
- Push switch 1 forwards to fully raise the towing hook.
- Next, push switch 1 backwards to bring the locking pin into contact with the hook 2.

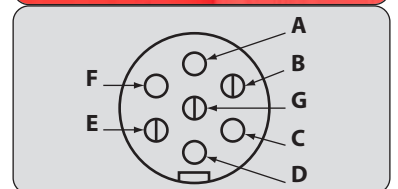

## 9 - REAR ELECTRIC SOCKET

- Connect the male plug to the female socket 1 on the lift truck and make sure the lights of the trailer or the light bar are working properly.
  - A - Rear left-hand indicator light.
  - B - Rear fog lights.
  - C - Ground.
  - D - Rear right-hand indicator light.
  - E - Rear right hand headlight.
  - F - Rear brake lights.
  - G - Left rear light and number plate.

## 10 - HYDRAULIC TRAILER BRAKE

### TRAILER BRAKE WITH A SINGLE "CL" LINE

- Connect the brake hose to the lift truck "CL" line 1.
- Make sure the trailer brakes are working properly and test the effects of braking before taking the trailer onto the public highway.

### TRAILER BRAKE WITH A DOUBLE "SL" AND "CL" LINE

- Connect the brake hose to the lift truck "CL" line 1.
- Connect the brake release hose to the lift truck "SL" line 2.
- Make sure the trailer brakes are working properly and test the effects of braking before taking the trailer onto the public highway.

### DOUBLE LINE TRAILER BRAKE TEST

- Press button B to display the "PREFERENCES" menu.
- Turn knob A to navigate through the menus and sub-menus.

TRANSMISSION	>	TRAILER BRAKE TEST
--------------	---	--------------------



## 11 - PNEUMATIC TRAILER BRAKE (OPTION)

The pressure gauge 1 indicates the working pressure of the pneumatic circuit (8 bar).

- Connect the brake hose to the lift truck "J" line.
- Connect the brake release hose to the lift truck "R" line.
- Make sure the trailer brakes are working properly and test the effects of braking before taking the trailer onto the public highway.

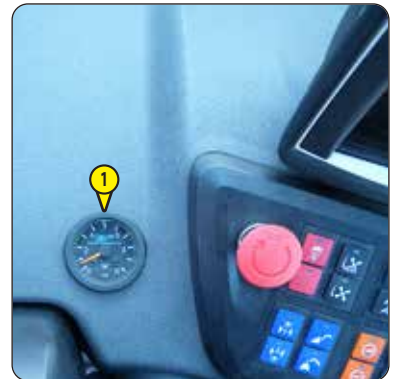

## DESCRIPTION AND USE OF THE OPTIONS

1 - 3 POLE 12V CONNECTOR.....	2-91
2 - SEMI-AUTOMATIC WHEEL ALIGNMENT.....	2-91
3 - ENGINE SPEED REGULATOR.....	2-91
4 - ATTACHMENT CIRCUIT FLOW RATE LIMITER.....	2-92
5 - SPEED LIMITER.....	2-92
6 - ATTACHMENT CIRCUIT CONTINUE FLOW.....	2-93
7 - BOOM SUSPENSION.....	2-93
8 - ATTACHMENT EASY HYDRAULIC CONNECTION.....	2-93
9 - ELECTRICAL ADJUSTMENT REAR VIEW MIRROR RIGHT.....	2-94
10 - REAR AND SIDE CAMERAS.....	2-94
11 - BOOM HEAD CAMERA.....	2-94
12 - ATTACHMENT HYDRAULIC LOCKING.....	2-95
13 - ATTACHMENT HYDRAULIC LOCKING ON JCB SINGLE CARRIAGE.....	2-95
14 - BOOM HEAD ELECTROVALVE.....	2-96
15 - BOOM HEAD ELECTROVALVE + HYDRAULIC ATTACHMENT LOCKING.....	2-96
16 - EXTERIOR DRAIN-BACK.....	2-97
17 - BOOM ELECTRICAL PREDISPOSITION.....	2-97
18 - ANGULAR SECTOR ON BOOM.....	2-97
19 - "A-B-C-D-E" MARKING ON BOOM.....	2-97
20 - DUAL EFFECT REAR HYDRAULIC CONTROL PREDISPOSITION.....	2-98
21 - TWO DOUBLE-ACTING REAR HYDRAULIC CONTROL PREDISPOSITIONS.....	2-98
22 - HYDRAULIC TRAILER HOOK + DOUBLE-ACTING REAR HYDRAULIC CONTROL PREDISPOSITION.....	2-99
23 - PREHEAT ROD.....	2-99
24 - COMBINED HYDRAULIC MOVEMENTS.....	2-99
25 - AUTOMATIC CENTRAL GREASING.....	2-100
26 - CAB FIRE EXTINGUISHER.....	2-100

## 1 - 3 POLE 12V CONNECTOR

For 12 V appliance and max. amperage 15A.



## 2 - SEMI-AUTOMATIC WHEEL ALIGNMENT

### ⚠ IMPORTANT ⚠

*Check the alignment of the front and rear wheels each time the lift truck is started.*

*Regularly check the alignment of the wheels when using the lift truck.*

*The wheels must be aligned and the lift truck must be in front steering wheels mode when used on public roads.*

*A green light comes on on the dashboard when the wheels are aligned.*

*It is not possible to change the steering mode above 11 km/h.*

*Contact your dealer if you have any questions.*



### CHANGING THE STEERING MODE



Front steering wheels (road mode).



Front and rear steering wheels in opposite directions (short steering).



Front and rear steering drive wheels in the same direction (crab steering).



Front steering wheels and locking of the rear wheel steering angle.

- Align the rear and front wheels.
- Select the desired steering mode, a flashing indicator lamp will confirm the selection.
- Turn the wheels as instructed on the information screen. The indicator lamp will remain steadily lit while the steering mode is enabled.

## 3 - ENGINE SPEED REGULATOR



### ⚠ IMPORTANT ⚠

*The engine speed regulator cannot under any circumstances be used while driving on the road.*



### USING THE REGULATOR

- Control the engine speed with lever 1.

### SPEED MEMORISATION

- Control the engine speed with lever 1 or the accelerator pedal.
- Hold down the  button to memorise the engine speed.
- Press the  button again or operate lever 1 to return to idle speed.

### ACTIVATING THE MEMORISED ENGINE SPEED



- Press the  button to activate the memorised engine speed.
- Confirm by pressing the  button a second time or pressing knob A.
- Press the  button again or operate lever 1 to return to idle speed.



## 4 - ATTACHMENT CIRCUIT FLOW RATE LIMITER

### FLOW RATE MEMORISATION

- Hold down the  button,  will appear on the information screen.

NOTE: Depending on the OPTIONS, you can have two attachment circuits  , press B to select the second circuit.

- Turn knob A to limit the flow rate to a value of your choice.
- Press knob A to confirm and proceed to the adjustment of the other line.
- Press knob A again to confirm and exit the setting menu.

### ACTIVATING THE MEMORISED FLOW RATE

- Press the  button to activate. The indicator lamp will show it is in use.
- Press the button again to deactivate.







## 5 - SPEED LIMITER

### ⚠ IMPORTANT ⚠

*BE CAREFUL when using the speed limiter while driving.*

As soon as  appears on the information screen, selecting the speed with button A will act directly on the lift truck and may cause it to decelerate sharply. Always reduce speed before use.

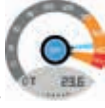
### USING SPEED MEMORISATION OR LIMITATION

- Turn the navigation knob A to change the mode .
- Press knob A or hold down the  button,  will appear on the information screen.
- Turn the knob A to select the speed.
- Press knob A to confirm and memorise.
- The memorised speed will be displayed on the information screen .

### ACTIVATING THE MEMORISED SPEED

- Press the  button to activate. The indicator lamp will show it is in use.
- Press the button again to deactivate.





## 6 - ATTACHMENT CIRCUIT CONTINUE FLOW



### ⚠ IMPORTANT ⚠

*This OPTION must only be used with an attachment requiring continuous hydraulic movement, such as a brush, feeder bucket, mixer, spray etc. It is strictly forbidden for use in handling operations and all other applications (winch, crane jib, crane jib with winch, hook, etc.).*

### USING CONTINUE FLOW MEMORISATION AND LIMITATION



- Turn the navigation knob A to change the working mode  / .

- Press knob A or hold down the  button,  will appear on the information screen.

NOTE: Depending on the OPTIONS, you can have two attachment circuits  , press B to select the second circuit.

- Turn the knob A to select the line.
- Confirm by pressing knob A.
- Turn knob A to set the desired flow rate.
- Press knob A to confirm and memorise.

### ACTIVATING THE MEMORISED CONTINUE FLOW

- Press the  button to activate continue flow.
- Confirm by pressing the  button a second time or pressing knob A.
- Press the  button again to deactivate.



## 7 - BOOM SUSPENSION

The boom suspension dampens shaking of the lift truck on rough ground (e.g. handling straw in a field).

### ⚠ IMPORTANT ⚠

*When you make a hydraulic downward or tilting movement, boom suspension is temporarily disabled and the button light  goes off. Boom suspension is active from 5 km/h.*

- Press the  button to activate. The indicator lamp will show it is in use.
- Press the button again to deactivate.
- When the engine is off, boom suspension is automatically deactivated.

NOTE: Forced boom suspension  allows it to be used at less than 5 km/h.

## 8 - ATTACHMENT EASY HYDRAULIC CONNECTION

For easy connection and disconnection of hydraulic attachments.

### OPERATION

- Switch on lift truck ignition.
- Press for two seconds on pushbutton 1 to release the attachment circuit hydraulic pressure.
- Connect or disconnect the quick couplers of the hydraulic attachment (◀ 4 - ADAPTABLE ATTACHMENTS AS AN OPTION ON THE RANGE: PICKING UP THE ATTACHMENTS).



## 9 - ELECTRICAL ADJUSTMENT REAR VIEW MIRROR RIGHT



## 10 - REAR AND SIDE CAMERAS

To activate a camera:

- Turn button A to select the rear or side camera .
- The screen displays the view of the selected camera.

The rear camera (SafeView) can be configured in automatic mode when in reverse gear.

- Press button B to display the "PREFERENCES" menu.
- Turn button A to select the menu.

SYSTEM	>	CAMERA (OPTION)
--------	---	-----------------

- Press knob A to confirm.
- Activate the automatic configuration using knob A.
- Press knob A to confirm.



## 11 - BOOM HEAD CAMERA

To activate the camera:

- Turn button A to select the boom head camera .
- The screen displays the view of the selected camera.

The boom head camera (HighView) can be configured in automatic mode as soon as the boom angle reaches 25°. When the boom goes back down, the previous screen reappears.

- Press button B to display the "PREFERENCES" menu.
- Turn button A to select the menu.

SYSTEM	>	CAMERA (OPTION)
--------	---	-----------------

- Press knob A to confirm.
- Activate the automatic configuration using knob A.
- Press knob A to confirm.

NOTE: "Manual" selection of the boom head camera from the information screen activates it permanently. The boom head camera (HighView) can be combined with the rear and side cameras option (SafeView).

## BOOM HEAD CAMERA INSTALLATION

- Lower the boom as far as it will go and turn off the lift truck ignition.
- Position the indexing finger 1 and tighten the thumbwheels 2.
- Point the camera using the thumbwheel 3.

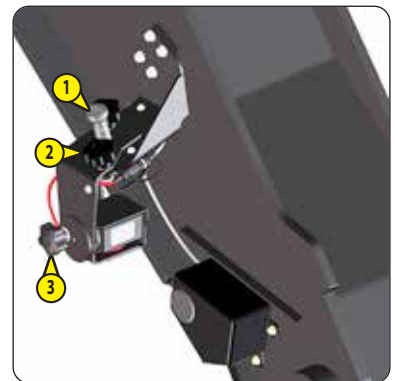

## 12 - ATTACHMENT HYDRAULIC LOCKING

Enables the attachment to be locked onto the carriage and a hydraulic attachment to be used by the same circuit.

### ⚠ IMPORTANT ⚠

Once the attachment is locked, return valve 1 to position B to prevent accidental release of the attachment.  
OR

Press the button  to shut off the attachment circuit hydraulic movements. The indicator lamp will show it is in use.

### ATTACHMENT LOCKING CONTROL

- Set valve 1 to position A.
- Push switch 2 forward to lock the attachment and backward to release it.
- Set valve 1 to position B.

### HYDRAULIC ATTACHMENT CONTROL

- Set valve 1 to position B.
- Push switch 2 forward or backward.

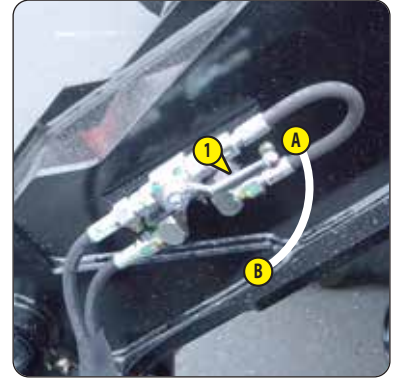

## 13 - ATTACHMENT HYDRAULIC LOCKING ON JCB SINGLE CARRIAGE

Enables the attachment to be locked onto the carriage and a hydraulic attachment to be used by the same circuit.

### ⚠ IMPORTANT ⚠

After locking the attachment, turn off the switch  (indicator lamp off) to prevent accidental unlocking of the attachment.  
OR

Press the button  to shut off the attachment circuit hydraulic movements. The indicator lamp will show it is in use.

### ATTACHMENT LOCKING CONTROL

- Set valve 1 to position A.
- Turn on the  switch (indicator lamp ON).
- Push switch 2 forward to lock the attachment and backward to release it.

### HYDRAULIC ATTACHMENT CONTROL

- Set valve 1 to position B.
- Turn on the  switch (indicator lamp ON).
- Push switch 2 forward or backward.

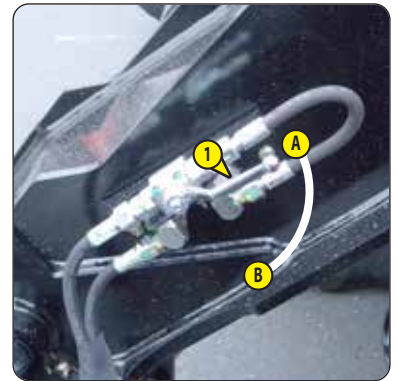

## 14 - BOOM HEAD ELECTROVALVE

Enables use of two hydraulic functions on the attachment circuit.

NOTE: For ease of connection of the quick-release couplers, decompress the hydraulic circuit by pressing button 1 on the electrovalve.

### ATTACHMENT LINE L1 CONTROL

- Turn off the  switch (indicator lamp off).
- Push switch 2 forward or backward to control attachment line L1.

### ATTACHMENT LINES L1 AND L2 CONTROL

- Turn on the  switch (indicator lamp ON).
- Push switch 2 forward or backward to control attachment line L1.
- Hold down button 3 and push switch 2 forward or backward to control attachment line L2.



## 15 - BOOM HEAD ELECTROVALVE + HYDRAULIC ATTACHMENT LOCKING

The addition of these two options on the attachment line allows two hydraulic functions to be used and locks the attachment onto the carriage.

NOTE: For ease of connection of the quick-release couplers, decompress the hydraulic circuit by pressing button 1 on the electrovalve.

**⚠ IMPORTANT ⚠**

*Once the attachment is locked, return valve 2 to position B to prevent accidental release of the attachment.*

### ATTACHMENT LINE L1 CONTROL

- Turn off the  switch (indicator lamp off).
- Push switch 3 forward or backward to control attachment line L1.

### ATTACHMENT LINE L1 AND L2 CONTROL + HYDRAULIC ATTACHMENT LOCKING

- Turn on the  switch (indicator lamp ON).
- Set valve 2 to position B.
- Push switch 3 forward or backward to control attachment line L1.
- Hold down button 4 and push switch 3 forward or backward to control attachment line L2.

### LOCKING AN ATTACHMENT

- Turn on the  switch (indicator lamp ON).
- Set valve 2 to position A.
- Hold down button 4 and push button 3 forward to lock the attachment and backward to release it.
- Set valve 2 to position B.

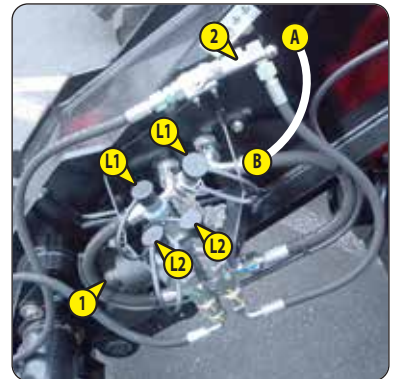

## **16 - EXTERIOR DRAIN-BACK**

Enables connection of a hydraulic attachment for which drain-back is required.



## **17 - BOOM ELECTRICAL PREDISPOSITION**

Enables an electrical function to be used at the boom head.



## **18 - ANGULAR SECTOR ON BOOM**

The angular sector displays the boom angle, and thus improves the reading of the load charts.



## **19 - "A-B-C-D-E" MARKING ON BOOM**

The marking indicates the outreach of the boom and therefore improves reading of the load charts.

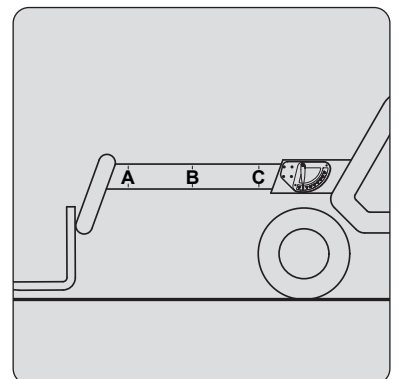

## 20 - DUAL EFFECT REAR HYDRAULIC CONTROL PREDISPOSITION

Enables the use of a hydraulic attachment at the rear of the lift truck (e.g. a trailer with hydraulic tipping).

### DOUBLE-ACTING REAR HYDRAULIC CONTROL L1

- Select the rear attachment hydraulic line .
- Push switch 1 forward or backward.



## 21 - TWO DOUBLE-ACTING REAR HYDRAULIC CONTROL PREDISPOSITIONS

Enables two hydraulic circuits at the rear of the lift truck to be selected for use.

### DOUBLE-ACTING REAR HYDRAULIC CONTROL L1

- Select the rear attachment hydraulic line .
- Push switch 1 forward or backward.

### DOUBLE-ACTING REAR HYDRAULIC CONTROL L2

- Select the rear attachment hydraulic line .
- Hold down button 2 and operate button 1 forwards or backwards.



## 22 - HYDRAULIC TRAILER HOOK + DOUBLE-ACTING REAR HYDRAULIC CONTROL PREDISPOSITION

Enables use of the towing hook (☞ TOWING DEVICE) or a hydraulic attachment at the rear of the lift truck.

### DOUBLE-ACTING REAR HYDRAULIC CONTROL L1

- Select the rear attachment hydraulic line .
- Hold down button 2 and operate button 1 forwards or backwards.

### HYDRAULIC TOWING HOOK L2

☞ TOWING DEVICE.



## 23 - PREHEAT ROD

Enables the engine to be kept warm during prolonged periods of stoppage and thus improves engine starting.

### ENVIRONMENTAL CONDITIONS FOR USE:

- Maximum ambient temperature for using preheating: + 25 °C.

### CONDITIONS FOR CONNECTION AND USE OF PREHEATING:

- The preheat system should not be used for an external ambient temperature higher than + 25 °C.
- It is essential that the power supply to the preheating system:
  - Is effected with a cable that conforms to the installation standards in force and contains a protective earth conductor.
  - Contains an appropriate sectioning system.
  - Incorporates an appropriate safety system against short circuits (fuses or circuit breaker).
- Only connect to and disconnect from the power supply while the unit is switched off and the engine is stopped.



**⚠ IMPORTANT ⚠**

*Make sure that the electrical extension is still correctly stored in its place in the document holder net.*

## 24 - COMBINED HYDRAULIC MOVEMENTS

This function enables several hydraulic movements to be combined.

- A - Lifting and tilting control lever.
- B - Telescoping control button.
- C - Attachment control button.

### COMBINED HYDRAULIC MOVEMENTS

- ↗ Boom lowering and forward tilting of the carriage.
- ↖ Boom lowering and backward tilting of the carriage.
- ↘ Boom lifting and forward tilting of the carriage.
- ↙ Boom lifting and backward tilting of the carriage.

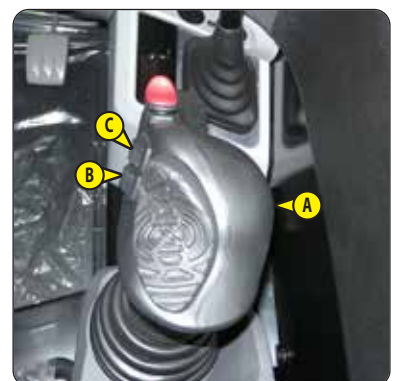

## 25 - AUTOMATIC CENTRAL GREASING

### **⚠ IMPORTANT ⚠**

*Before using the lift truck, check the condition of the greasing unit and check the grease level, topping it up if necessary (↩ 3 - MAINTENANCE: 10H - DAILY SERVICE OR EVERY 10 HOURS OF SERVICE).*

*Never use the lift truck with the grease tank empty.*

*When washing the lift truck with a high-pressure cleaner, the greasing unit must be protected from splashes.*

This option ensures automatic lubrication of all of the lift truck's greasing points from start-up.

After turning on the ignition, check the automatic greasing control indicator light 1:

- Light on for 3 s = system OK.
- Light flashing every 0.5 s = greasing cycle in progress.
- Light flashing every 1 s = grease level low (error code 8C-7F07E.11)
- Light on continuous = grease tank empty or system error

In the event of a system error, perform a test cycle by pressing test button 2:

- Press once and the light flashes once every 2 seconds and launches the test on output 1.
- Press twice and the light flashes twice every 2 seconds and launches the test on output 2.

NOTE: After an interruption, when the system is powered back on, the greasing cycle continues where it stopped previously.

If the system error persists, contact your dealer as soon as possible.



## 26 - CAB FIRE EXTINGUISHER

### **⚠ IMPORTANT ⚠**

*Regularly check your fire extinguisher.*

*After use, replace the fire extinguisher with a new one of the same type.*



# ***3 - MAINTENANCE***

### 3 - MAINTENANCE

<b>ORIGINAL MANITOU SPARE PARTS AND EQUIPMENT</b>	<b>3-3</b>
<b>FORKLIFT TRUCK MAINTENANCE</b>	<b>3-4</b>
<b>DAILY AND WEEKLY MAINTENANCE</b>	<b>3-4</b>
<b>MANDATORY FIRST 500 HOURS OR 6 MONTHS SERVICE</b>	<b>3-5</b>
<b>PERIODIC SERVICE</b>	<b>3-6</b>
<b>OCCASIONAL MAINTENANCE AND OPERATION</b>	<b>3-8</b>
<b>FILTER CARTRIDGES AND BELTS</b>	<b>3-9</b>
<b>LUBRICANTS AND FUEL</b>	<b>3-10</b>
<b>➤ 10H - DAILY SERVICE OR EVERY 10 HOURS OF SERVICE</b>	<b>3-12</b>
<b>➤ 50H - WEEKLY SERVICE OR EVERY 50 HOURS OF SERVICE</b>	<b>3-14</b>
<b>➤ ① 500H - PERIODIC SERVICE - EVERY 500 HOURS OF SERVICE OR 1 YEAR</b>	<b>3-18</b>
<b>➤ ② 1000H - PERIODIC SERVICE - EVERY 1,000 HOURS OF SERVICE OR 2 YEARS</b>	<b>3-22</b>
<b>➤ ③ 2000H - PERIODIC SERVICE - EVERY 2000 HOURS OF SERVICE OR 4 YEARS</b>	<b>3-28</b>
<b>➤ OCCASIONAL MAINTENANCE</b>	<b>3-32</b>
<b>➤ OCCASIONAL OPERATION</b>	<b>3-34</b>

## ORIGINAL MANITOU SPARE PARTS AND EQUIPMENT

OUR LIFT TRUCKS MUST BE SERVICED USING ORIGINAL MANITOU PARTS.

### **BY ALLOWING THE USE OF NON ORIGINAL MANITOU PARTS, YOU RISK:**

---

**⚠ IMPORTANT ⚠**

**THE USE OF COUNTERFEIT PARTS OR COMPONENTS NOT APPROVED BY THE MANUFACTURER, MEANS YOU LOSE THE BENEFIT OF THE CONTRACTUAL GUARANTEE.**

- Legally - to be held responsible in the event of an accident.
- Technically - to cause operating malfunctions or shorten the life of the lift truck.

### **BY USING ORIGINAL MANITOU PARTS FOR MAINTENANCE OPERATIONS, YOU BENEFIT FROM OUR KNOW-HOW**

---

Through its network, MANITOU provides the user with,

- Know-how and competence.
- The guarantee of high-quality work.
- Original replacement parts.
- Help with preventive maintenance.
- Efficient help with diagnosis.
- Improvements due to experience feedback.
- Operator training.
- Only the MANITOU network has detailed knowledge of the design of the lift truck and therefore the best technical ability to provide maintenance.

**⚠ IMPORTANT ⚠**

**ORIGINAL REPLACEMENT PARTS ARE DISTRIBUTED EXCLUSIVELY BY MANITOU AND ITS DEALER NETWORK.**

*The dealer network list is available on the MANITOU web site: [www.manitou.com](http://www.manitou.com)*

## FORKLIFT TRUCK MAINTENANCE

### DAILY AND WEEKLY MAINTENANCE



**THE OPERATOR IS AUTHORISED TO CARRY OUT THIS MAINTENANCE.**

These maintenance operations enable the operator to maintain the lift truck in a clean and safe condition.

### MANDATORY FIRST 500 HOURS OR 6 MONTHS SERVICE



**THIS SERVICE MUST BE CARRIED OUT AFTER THE FIRST 500 HOURS OF SERVICE OR WITHIN THE 6 MONTHS FOLLOWING PUTTING THE MACHINE INTO SERVICE (WHICHEVER OCCURS FIRST).**

### PERIODIC SERVICE



**THE PERIODIC MAINTENANCE MUST BE CARRIED OUT BY A PROFESSIONAL APPROVED BY THE MANITOU NETWORK**

### MAINTENANCE SCHEDULE

This schedule enables the operator to keep up with the periodic service of the lift truck by notifying the total number of hours of operation and the date of the service performed by the professional approved by the MANITOU network.

### OCCASIONAL MAINTENANCE AND OPERATION

These maintenance tasks and operations are to be performed as required for the safety and upkeep of the lift truck.

## DAILY AND WEEKLY MAINTENANCE

### 🔄 10H - DAILY SERVICE OR EVERY 10 HOURS OF SERVICE

- CHECK	Lift truck environment .....	3-12
- CHECK	Engine oil level .....	3-12
- CHECK	Cooling liquid level .....	3-12
- CHECK	Fuel pre-filter .....	3-13
- CHECK	Longitudinal stability limiter and warning device .....	3-13
- CHECK	Greasing unit level (OPTION) .....	3-13

### 🔄 50H - WEEKLY SERVICE OR EVERY 50 HOURS OF SERVICE

- CHECK	Reduction gearbox seal .....	3-14
- CHECK	Tyre pressures .....	3-14
- CHECK	Wheel nut tightening .....	3-14
- CHECK	Front axle differential seal .....	3-14
- CHECK	Rear axle differential seal .....	3-14
- CHECK	Front wheel reducer seals .....	3-14
- CHECK	Rear wheel reducer seals .....	3-14
- CHECK	Boom pad slide pathways .....	3-15
- CHECK	Hydraulic oil level .....	3-15
- CHECK	Windscreen washer liquid level .....	3-15
- CLEAN	Radiator core .....	3-16
- CLEAN	Dry air filter cartridge .....	3-16
- CLEAN	Condenser harness (Air conditioning OPTION) .....	3-16
- LUBRICATE	General lubrication .....	3-17

## MANDATORY FIRST 500 HOURS OR 6 MONTHS SERVICE

### FIRST 500 HOURS BEFORE THE FIRST 6 MONTHS

- If the lift truck has reached the first 500 hours of service before the first 6 months have expired, perform both the mandatory service and periodic 500 H service (◀ ➡ ① 500H - PERIODIC SERVICE - EVERY 500 HOURS OF SERVICE OR 1 YEAR).

### FIRST 6 MONTHS BEFORE THE FIRST 500 HOURS

- If the lift truck has not completed 500 hours of service in the first 6 months, just carry out the mandatory service.

## ➡ MANDATORY SERVICE

- CHECK	Reduction gearbox seal .....	3-14
- CHECK	Tyre pressures .....	3-14
- CHECK	Wheel nut tightening .....	3-14
- CHECK	Front axle differential seal .....	3-14
- CHECK	Rear axle differential seal .....	3-14
- CHECK	Front wheel reducer seals .....	3-14
- CHECK	Rear wheel reducer seals .....	3-14
- CHECK	Boom pad slide pathways .....	3-15
- CHECK	Hydraulic oil level .....	3-15
- CHECK	Windscreen washer liquid level .....	3-15
- CLEAN	Radiator core .....	3-16
- CLEAN	Dry air filter cartridge .....	3-16
- CLEAN	Condenser harness (Air conditioning OPTION) .....	3-16
- LUBRICATE	General lubrication .....	3-17
- CHECK	Parking brake .....	3-18
- CHECK	Fork wear * .....	3-21
- CHECK	Seat belt .....	3-22
- CHECK	Engine silent blocks * .....	3-27
- CHECK	Reduction gearbox silent blocks * .....	3-27
- CHECK	Boom pad wear * .....	3-27
- CHECK	Condition of wiring harnesses and cables * .....	3-27
- CHECK	Lights and signals * .....	3-27
- CHECK	Warning indicators * .....	3-27
- CHECK	Condition of the rear view mirrors * .....	3-27
- CHECK	Cabin structure * .....	3-27
- CHECK	Frame structure * .....	3-27
- CHECK	Attachment carriage * .....	3-27
- CHECK	Condition of attachments * .....	3-27

*\* Consult your dealer.*

## PERIODIC SERVICE

### MAINTENANCE SCHEDULE

	⬇ OR ⬇					
WHEN DUE ➡	FIRST 6 MONTHS	FIRST 500 HOURS	500 H or 1 YEAR	1000 H or 2 YEARS	1500 H or 3 YEARS	2000 H or 4 YEARS
PERIODIC SERVICE ➡	MANDATORY SERVICE	MANDATORY SERVICE + ①	①	①+②	①	①+②+③
MACHINE COUNTER ➡						
DATE OF SERVICING ➡						

WHEN DUE ➡	2500 H or 5 YEARS	3000 H or 6 YEARS	3500 H or 7 YEARS	4000 H or 8 YEARS	4500 H or 9 YEARS	5000 H or 10 YEARS	5500 H or 11 YEARS
PERIODIC SERVICE ➡	①	①+②	①	①+②+③	①	①+②	①
MACHINE COUNTER ➡							
DATE OF SERVICING ➡							

WHEN DUE ➡	6000 H or 12 YEARS	6500 H or 13 YEARS	7000 H or 14 YEARS	7500 H or 15 YEARS	8000 H or 16 YEARS	8500 H or 17 YEARS	9000 H or 18 YEARS
PERIODIC SERVICE ➡	①+②+③	①	①+②	①	①+②+③	①	①+②
MACHINE COUNTER ➡							
DATE OF SERVICING ➡							

### ➡ ① 500H - PERIODIC SERVICE - EVERY 500 HOURS OF SERVICE OR 1 YEAR

- CHECK	Hydraulic oil .....	3-18
- CHECK	Parking brake .....	3-18
- REPLACE	Engine oil .....	3-19
- REPLACE	Engine oil filter .....	3-19
- REPLACE	Hydrostatic transmission oil filter cartridge .....	3-19
- REPLACE	Front axle differential oil .....	3-20
- REPLACE	Hydraulic return oil filter cartridge .....	3-20
- REPLACE	Hydraulic oil tank breather .....	3-20
- REPLACE	Cab fan filters .....	3-21
- REPLACE	Filter coupling (OPTIONAL Automatic central greasing) .....	3-21
- CHECK	Fork wear * .....	3-21

*\* Consult your dealer.*

## ➔ ② 1000H - PERIODIC SERVICE - EVERY 1,000 HOURS OF SERVICE OR 2 YEARS

### ALSO PERFORM THE 500 HOUR PERIODIC MAINTENANCE OPERATIONS.

- CHECK	Seat belt .....	3-22
- CLEAN	"Stationary lift truck" exhaust sublimation .....	3-22
- CLEAN	Fuel tank .....	3-23
- REPLACE	Fuel tank breather .....	3-23
- REPLACE	Coolant .....	3-23
- REPLACE	"DEF"(Diesel Exhaust Fluid) supply pump filter .....	3-24
- REPLACE	Dry air filter cartridge .....	3-24
- REPLACE	Fuel pre-filter .....	3-25
- REPLACE	Fuel filter .....	3-25
- REPLACE	Reduction gearbox oil .....	3-25
- REPLACE	Rear axle differential oil .....	3-26
- REPLACE	Front wheel reducer oil .....	3-26
- REPLACE	Rear wheel reducer oil .....	3-26
- CHECK	Engine silent blocks * .....	3-27
- CHECK	Reduction gearbox silent blocks * .....	3-27
- CHECK	Boom pad wear * .....	3-27
- CHECK	Condition of wiring harnesses and cables * .....	3-27
- CHECK	Lights and signals * .....	3-27
- CHECK	Warning indicators * .....	3-27
- CHECK	Condition of the rear view mirrors * .....	3-27
- CHECK	Cabin structure * .....	3-27
- CHECK	Frame structure * .....	3-27
- CHECK	Attachment carriage * .....	3-27
- CHECK	Condition of attachments * .....	3-27

*\* Consult your dealer.*

## ➔ ③ 2000H - PERIODIC SERVICE - EVERY 2000 HOURS OF SERVICE OR 4 YEARS

### ALSO PERFORM THE 500 HOUR AND 1,000 HOUR PERIODIC MAINTENANCE OPERATIONS.

- CHECK	Wheel nut tightening torques .....	3-28
- REPLACE	Dry air filter safety cartridge .....	3-28
- REPLACE	Alternator belt .....	3-28
- REPLACE	Hydraulic oil .....	3-29
- CLEAN	Hydraulic oil tank suction strainers .....	3-29
- REPLACE	Ventilation control filter .....	3-29
- CHECK	Radiator * .....	3-30
- CHECK	Transmission pressures * .....	3-30
- CHECK	Steering * .....	3-30
- CHECK	Steering swivel joints * .....	3-30
- CHECK	Condition of boom assembly * .....	3-30
- CHECK	Bearings and bushings * .....	3-30
- CHECK	Condition of hoses and flexible pipes * .....	3-30
- CHECK	Condition of cylinders (leakage, rods) * .....	3-30
- CHECK	Hydraulic circuit pressures * .....	3-30
- CHECK	Bearings and bushings * .....	3-30
- CLEAN	Air conditioning (OPTION) * .....	3-30
- REPLACE	Compressor belt (air conditioning OPTION) * .....	3-31

*\* Consult your dealer.*

## OCCASIONAL MAINTENANCE AND OPERATION

### ↻ OCCASIONAL MAINTENANCE

---

- REPLACE	Wheels .....	3-32
- REPLACE	Battery .....	3-32
- ADJUST	Front headlights .....	3-33
- RESET	Longitudinal stability limiter and warning device .....	3-33

### ↻ OCCASIONAL OPERATION

---

- TOW OR WINCH	Lift truck .....	3-34
- SLING	Lift truck .....	3-35
- TRANSPORT	Lift truck .....	3-36

## FILTER CARTRIDGES AND BELTS

### ➔ ① 500H - PERIODIC SERVICE - EVERY 500 HOURS OF SERVICE OR 1 YEAR

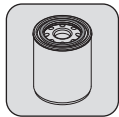

ENGINE OIL FILTER

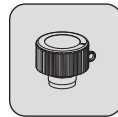

HYDRAULIC OIL TANK PLUG



HYDROSTATIC TRANSMISSION OIL FILTER CARTRIDGE

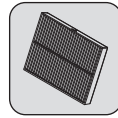

INTERIOR CAB VENTILATION FILTER

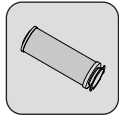

HYDRAULIC RETURN OIL FILTER CARTRIDGE

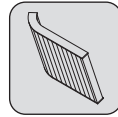

EXTERIOR CAB VENTILATION FILTER

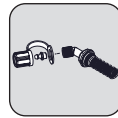

FILTER COUPLING (OPTIONAL AUTOMATIC CENTRAL GREASING)

### ➔ ② 1000H - PERIODIC SERVICE - EVERY 1,000 HOURS OF SERVICE OR 2 YEARS

*ALSO ADD FILTER CARTRIDGES FOR PERIODIC MAINTENANCE AFTER 500 HOURS OF SERVICE.*



DRY AIR FILTER CARTRIDGE

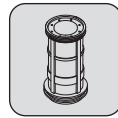

"DEF"(Diesel Exhaust Fluid) FEED PUMP FILTER

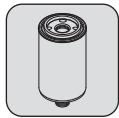

FUEL PRE-FILTER

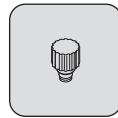

FUEL TANK BREATHER

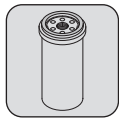

FUEL FILTER

### ➔ ③ 2000H - PERIODIC SERVICE - EVERY 2,000 HOURS OF SERVICE OR 4 YEARS

*ALSO ADD FILTER CARTRIDGES FOR PERIODIC MAINTENANCE AT 500 HOURS AND 1,000 HOURS OF SERVICE.*

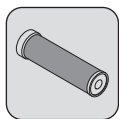

SAFETY DRY AIR FILTER CARTRIDGE

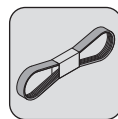

ALTERNATOR BELT

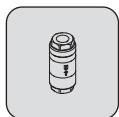

SELF-CLEANING FAN FILTER



ALTERNATOR BELT (PNEUMATIC TRAILER BRAKE OPTION)

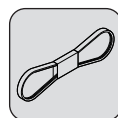

COMPRESSOR BELT (AIR CONDITIONING OPTION)

### ➔ OCCASIONAL MAINTENANCE

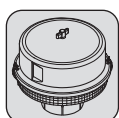

SELF-CLEANING PRE-FILTER

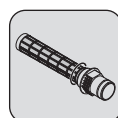

SUCTION STRAINER FOR HYDRAULIC OIL TANK (hydraulic circuit)

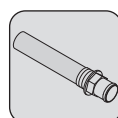

SUCTION STRAINER FOR HYDRAULIC OIL TANK (hydrostatic circuit)



<b>REAR AXLE</b>												
PARTS TO BE LUBRICATED		CAPACITY	RECOMMENDATION									
			-40 °C	-30	-20	-10	0	+10	+20	+30	+40	+50 °C
REAR AXLE DIFFERENTIAL		7.3 ℓ	SPECIAL MANITOU OIL FOR IMMersed BRAKES									
REAR WHEEL REDUCING GEAR		2 x 0.8 ℓ	MANITOU SAE80W90 MECHANICAL TRANSMISSION OIL									
REAR AXLE OSCILLATION			MANITOU BLUE MULTI-PURPOSE LUBRICANT									
REAR WHEEL REDUCING GEAR PIVOTS			MANITOU BLACK MULTI-PURPOSE LUBRICANT									

<b>BOOM</b>												
PARTS TO BE LUBRICATED		CAPACITY	RECOMMENDATION									
			-40 °C	-30	-20	-10	0	+10	+20	+30	+40	+50 °C
BOOM PAD SLIDE PATHWAYS			MANITOU BLACK MULTI-PURPOSE LUBRICANT									
GREASING OF THE BOOM			MANITOU BLUE MULTI-PURPOSE LUBRICANT									

<b>HYDRAULICS</b>												
PARTS TO BE LUBRICATED		CAPACITY	RECOMMENDATION									
			-40 °C	-30	-20	-10	0	+10	+20	+30	+40	+50 °C
HYDRAULIC OIL TANK		81 ℓ							ISO VG 100			
									ISO VG 68			
									MANITOU ISO VG 46 HYDRAULIC OIL			
									ISO VG 37			
									ISO VG 32			

<b>CAB</b>												
PARTS TO BE LUBRICATED		CAPACITY	RECOMMENDATION									
			-40 °C	-30	-20	-10	0	+10	+20	+30	+40	+50 °C
CAB DOOR			MANITOU BLUE MULTI-PURPOSE LUBRICANT									
WINDSCREEN WASHER TANK		2 ℓ	WINDSCREEN WASHER LIQUID									
COMPRESSOR (AIR CONDITIONING OPTION)		0.24 ℓ	R12 MINERAL OIL									

<b>AUTOMATIC CENTRAL GREASING (OPTION)</b>												
DESCRIPTION		CAPACITY	RECOMMENDATION									
			-40 °C	-30	-20	-10	0	+10	+20	+30	+40	+50 °C
GREASING UNIT TANK		3 ℓ	MANITOU BLACK MULTI-PURPOSE LUBRICANT									

**CHECK**

**Lift truck environment**

Carry out a general inspection around the lift truck:

- Fluid leaks or stains on the ground.
- Additional objects on the lift truck and in the cabin.
- Mounting and locking of the attachment.
- Mounting and adjustment of rear-view mirrors.
- Condition of the tyres, to detect cuts, blisters, wear, etc.

**⚠ IMPORTANT ⚠**

*Follow the operator instructions (↩ 1 - OPERATING AND SAFETY INSTRUCTIONS: OPERATOR INSTRUCTIONS).*

**CLEANLINESS OF THE FORKLIFT**

- Cleanliness of lights and rear-view mirror.
- Excess dirt or build-up of material (e.g. straw, flour, sawdust, organic waste, etc.).
- On a daily basis, according to the conditions of use and the environment, the operator should ensure that the forklift truck is kept in a clean condition.
- Particular attention should be paid to accumulations of flammable materials (e.g. straw, flour, sawdust, organic waste, etc.) and fuel or lubricant leaks, as these significantly increase the risk of fire outbreaks.
- A regular inspection of the whole lift truck, especially the engine housing and the central part of the frame, is necessary to see how frequently it needs to be cleaned to prevent these potential accumulations of material or leakages.

**CHECK**

**Engine oil level**

Place the lift truck on level ground with the engine stopped, and let the oil settle in the sump.

- Open the engine cover.
- Pull out dipstick 1.
- Clean the dipstick and check the correct level between the two notches.
- If necessary, add oil (↩ LUBRICANTS AND FUEL) through the filler hole 2.
- Visually check that there is no leakage or seepage.



**CHECK**

**Cooling liquid level**

Place the lift truck on level ground with the engine stopped, and allow the engine to cool.

**⚠ IMPORTANT ⚠**

*To avoid any risk of spraying or scalding, wait until the engine has cooled down before removing the cooling system filler plug.*

*In the event of an emergency, it is possible to use water as the coolant, but then proceed to drain the coolant circuit as quickly as possible.*

- Open the engine cover.
- The liquid must be at the MAX. level on the expansion tank 1.
- If necessary, add coolant (↩ LUBRICANTS AND FUEL) through the filler hole 2.
- Visually check that there is no leakage or seepage.



## CHECK

## Fuel pre-filter

### ⚠ IMPORTANT ⚠

*Carefully clean the outside of the pre-filter and its holder, to prevent dust from getting into the system.*

- Open the engine cover.
- Disconnect electrical wiring harness 1 from the fuel pre-filter.
- Place a hose on the drain plug 2 and the other end in a container.
- Unscrew the drain plug 2 by two turns.
- Allow the diesel fuel to flow out until it is free from impurities and water.
- Re-tighten drain plug 2 and reconnect the wiring harness 1.



## CHECK

## Longitudinal stability limiter and warning device

Place the lift truck on flat, level ground with the wheels straight.

- Press button B to display the "PREFERENCE" menu
- Turn knob A to navigate through the menus and sub-menus.

HYDRAULICS > STABILITY TEST

- Press knob A to confirm.
- Follow the steps described on the information screen (OK = press button A).

### ⚠ IMPORTANT ⚠

*If an error code is displayed, recalibrating the longitudinal stability limiter and warning device may resolve the problem (⚠ OCCASIONAL MAINTENANCE).*



## CHECK

## Greasing unit level (OPTION)

Check the following points of the greasing system:

- The grease level in the greasing unit tank.
- The condition of the greasing unit (damage and leaks).
- No damage or leaks on the primary and secondary lines.
- There must be a collar of fresh grease on all of the greasing points.

The greasing unit is equipped with a filter coupling 1 on which a grease pump can be installed.

- Top up with the recommended grease as required (⚠ LUBRICANTS AND FUEL).

### FILLING PROCEDURE:

- Carefully clean the filter coupling 1 and your filling system.
- Connect your filling system to the filter coupling.
- Fill the tank to its maximum level as indicated on the tank.

### ⚠ IMPORTANT ⚠

*Never fill the tank higher than the maximum level indicated, as this may damage the system.*

*If filling is difficult, check the condition of the filter coupling and replace it.*

- Remove your filling system.
- Clean the filter coupling before putting it back.



## ➤ 50H - WEEKLY SERVICE OR EVERY 50 HOURS OF SERVICE

### CHECK

### Reduction gearbox seal

Place the lift truck on level ground with the engine stopped.

- Visually check for any traces of seepage or leakage from the various filler, level and drain plugs.
- If there is any leakage or seepage, check the level.
- Remove the level and filling plug 1, the oil should be flush with the edge of the hole.
- If necessary, add oil (↖ LUBRICANTS AND FUEL) by the same hole.
- Refit and tighten the level plug (tightening torque 34 - 49 N.m).

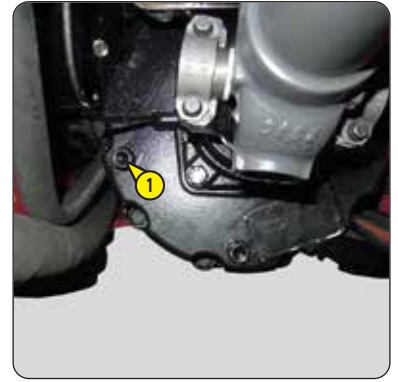

### CHECK

### Tyre pressures

### CHECK

### Wheel nut tightening

#### ⚠ IMPORTANT ⚠

*Check that the air hose is correctly connected to the tyre valve before inflating and keep all persons at a distance during inflation. Follow the recommended tyre pressures.*

- Check the wheel nut tightening. Non-compliance with this instruction can lead to deterioration and breakage of the wheel bolts and distortion of the wheels.
- Check and restore tyre pressures if necessary (↖ 2 - DESCRIPTION: TYRES).

NOTE: There is an OPTIONAL wheel tool kit.

### CHECK

### Front axle differential seal

### CHECK

### Rear axle differential seal

Place the lift truck on level ground with the engine stopped.

- Visually check that there is no leakage or seepage.
- If there is any leakage or seepage, check the level:
  - Remove the level plug 1, the oil should be flush with the edge of the hole.
  - If necessary, add oil (↖ LUBRICANTS AND FUEL) through the filler hole 2.
  - Refit and tighten the level plug 1 (tightening torque 34 - 49 N.m).

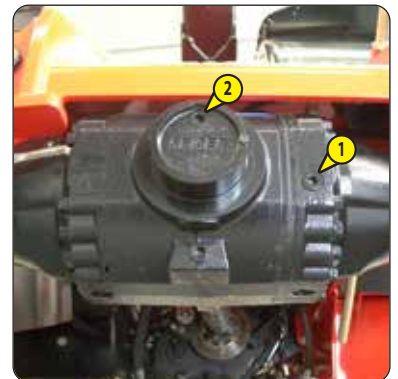

### CHECK

### Front wheel reducer seals

### CHECK

### Rear wheel reducer seals

Place the lift truck on level ground with the engine stopped.

- Visually check that there is no leakage or seepage.
- If there is any leakage or seepage, check the level:
  - Place level plug 1 in a horizontal position.
  - Remove the level plug; the oil should be flush with the edge of the opening.
  - If necessary, add oil (↖ LUBRICANTS AND FUEL) by the same hole.
  - Refit and tighten the level plug (tightening torque 34 - 49 N.m).



## CHECK

### Boom pad slide pathways

To preserve optimum operation, the pad slide pathways should be correctly lubricated:

#### ⚠ IMPORTANT ⚠

**MANDATORY GREASING OF THE BOOM AFTER:**  
*Cleaning the boom, especially after using high pressure cleaner.  
The forklift has been unused for a long period of time.*

- Fully extend the boom.
- Check the condition of the surface of the pad slide pathways, surface run in (steel whitened) without traces of corrosion.
- If necessary lubricate the pad slide pathways (☞ LUBRICANTS AND FUEL).
- Telescope the boom several times in order to spread the lubricant evenly.
- Remove the surplus lubricant.

#### ⚠ IMPORTANT ⚠

*If the lift truck is used in an abrasive environment (dust, sand, coal.) use lubricating varnish (MANITOU part no.: 483536). Please consult your dealer.*



## CHECK

### Hydraulic oil level

Place the lift truck on level ground with the engine stopped, and the boom retracted and lowered as far as possible.

#### ⚠ IMPORTANT ⚠

*Use a clean funnel and clean the underside of the oil drum before filling.*

- Check dipstick 1, the correct level should be at the maximum level.
- If necessary, add oil (☞ LUBRICANTS AND FUEL).
- Remove the cap 2.
- Add oil through filler port 2.
- Refit the cap.
- Visually check that there is no leakage or seepage.



## CHECK

### Windscreen washer liquid level

- Open the protective casing 1 with the ignition key.
- Visually check the level in tank 2.
- If necessary add windscreen washer fluid (☞ LUBRICANTS AND FUEL).
- Remove the cap 3.
- Add windscreen washer liquid through filler port.
- Refit the cap.



## CLEAN

### Radiator core

#### **⚠ IMPORTANT ⚠**

*In a polluting atmosphere, clean the radiator cores every day. Do not use a water jet or high-pressure steam as this could damage the radiator fins.*

- Open the engine cover.
- If necessary, clean the suction grid on the engine hood.
- Using a soft cloth, clean the radiator core 1 in order to remove as much dirt as possible.
- Remove dirt via the panel 2 using handle 3.



## CLEAN

### Dry air filter cartridge

When used in very dusty atmospheres there are pre-filtration elements (≪ FILTER CARTRIDGES AND BELTS). The cartridge checking and cleaning interval must also be reduced.

#### **⚠ IMPORTANT ⚠**

*If the clogging indicator lamp comes on, this operation must be carried out as soon as possible (within a maximum of 1 hour). Never use the lift truck without an air filter or with an air filter that is damaged.*

*Respect the safety distance of 30 mm between the air jet and the cartridge to avoid tearing or piercing the cartridge. The cartridge must not be blown near the air filter box. Never clean the cartridge by tapping it against a hard surface. Your eyes must be protected during this intervention.*

*Never clean the dry air filter cartridge by washing it in liquid. Do not clean by any means the safety cartridge located inside the filter cartridge, change it for a new one if it is clogged or damaged.*

- For the dismantling and refitting of the cartridge (≪ 1000H: REPLACE Air filter cartridge).
- Clean the filter cartridge using a compressed air jet (max. pressure 3 bars) directed from the top to the bottom and from the inside towards the outside at a minimum distance of 30 mm from the cartridge wall.
- Cleaning is completed when there is no more dust on the cartridge.
- Clean the cartridge seal surface with a damp, clean lint-free cloth and grease with a silicone lubricant (MANITOU part no.: 479292).
- Check visually the outer condition of the air filter and its mounts. Verify the condition of the hoses and their mounts also.

## CLEAN

### Condenser harness (Air conditioning OPTION)

#### **⚠ IMPORTANT ⚠**

*In a polluting atmosphere, clean the radiator core every day.*

*Do not use a water jet or high-pressure steam as this could damage the condenser fins.*

- Remove the protective grid 1 and clean it if necessary.
- Visually check whether the condenser is clean and clean it if necessary.
- Clean the condenser using a compressed air jet aimed in the same direction as the air flow.
- Clean with the fans running for best results.



To be carried out weekly, if the lift truck has been operated for less than 50 hours during the week.

**⚠ IMPORTANT ⚠**

*In the event of prolonged use in an extremely dusty or oxidising atmosphere, reduce this interval to every 10 hours of service or every day.*

Clean, then lubricate the following points with grease (← LUBRICANTS AND FUEL) and remove the surplus.

**BOOM**

- 1 - Lubricators of the boom pin (2 lubricators).
- 2 - Lubricators of the carriage pin (2 lubricators).
- 3 - Lubricator of the tilting cylinder foot pin (1 lubricator).
- 4 - Lubricator of the tilt cylinder head axle (1 lubricator).
- 5 - Lubricators of the carriage connecting rod pins (3 lubricators).
- 6 - Lubricator of the lifting cylinder foot pin (1 lubricator).
- 7 - Lubricator of the lifting cylinder head pin (1 lubricator).
- 8 - Lubricator of the compensation cylinder foot pin (1 lubricator).
- 9 - Lubricator of the compensation cylinder head pin(1 lubricator).

**FRONT AND REAR WHEEL REDUCTION GEAR PIVOTS**

- 10 - Lubricators of the wheel reduction gear pivot pins (8 lubricators).

**REAR AXLE OSCILLATION**

- 11 - Rear axle oscillation lubricators (2 lubricators).

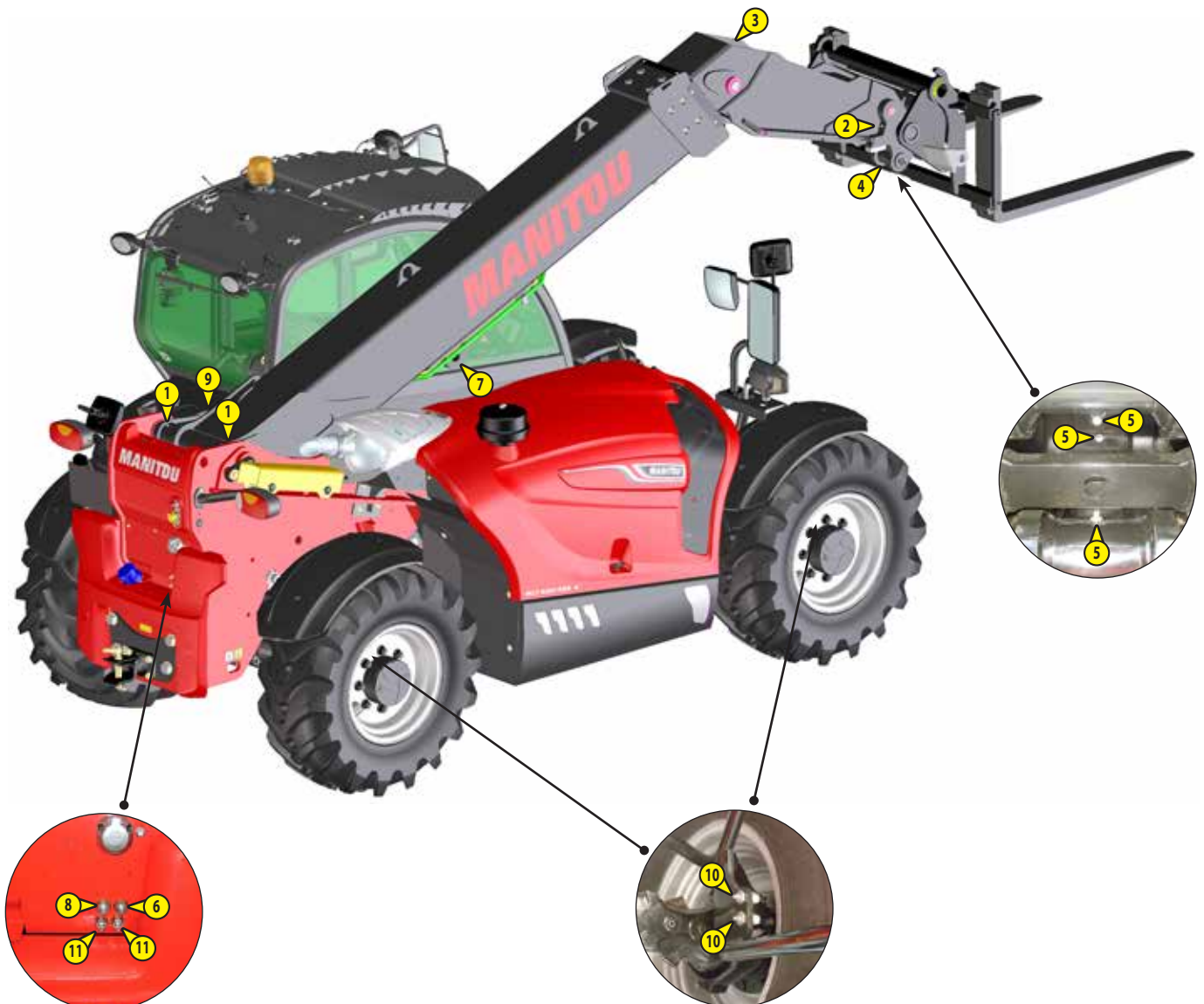

**CHECK**

**Hydraulic oil**

MANITOU offers a hydraulic oil analysis kit which might make it possible to delay the recommended deadline in the periodic maintenance schedule (2,000 hours). In this case we recommend an analysis of the hydraulic oil every 500 hours or 1 year of service.

The oil analysis kit also makes it possible to confirm the oil quality so as to obtain a deadline of 2,000 hours for specific uses causing constraints on the hydraulic circuit: extreme environmental conditions, use of the attachments with a very high hydraulic flow rate (such as a sweeper, or a concrete mixer).

- Order an oil analysis kit from your dealer.
- Upon receiving the kit, take a sample of oil and follow the instructions shown on the kit.
- According to the results, keep the analysis report or replace the hydraulic oil.

Oil analysis kit (MANITOU part no.: 958162)



**CHECK**

**Parking brake**

**⚠ IMPORTANT ⚠**

*The manufacturer's stop settings must not be changed under any circumstances.*

**BRAKE SYSTEM CHECK**

Place the lift truck on level ground with the engine stopped.

- Remove the cover plate 1.
- NOTE: When removing cover plates and hatches, clean the surrounding area and remove any accumulations of flammable materials.
- If necessary, correctly clean the environment of the connecting rods and setting stops.
- Release then apply the parking brake several times, checking that the connecting rods 2 return to the stops 3.
- In the event of a malfunction, contact your dealer.

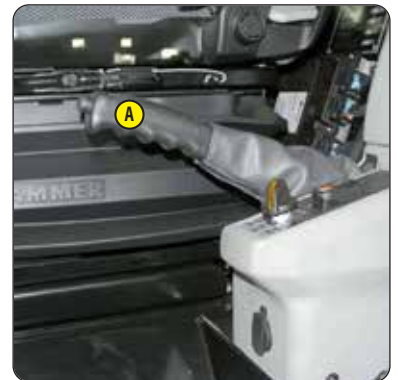

**BRAKE CHECK**

Place the lift truck on a slope of 15% with the rated load in the transport position.

- Immobilise the lift truck using the service brake pedal.
- Firmly apply the parking brake in position A (400 N.m).
- Release the service brake pedal.
- Braking is working correctly if the lift truck remains stationary on the slope.
- In the event of poor braking, contact your dealer.

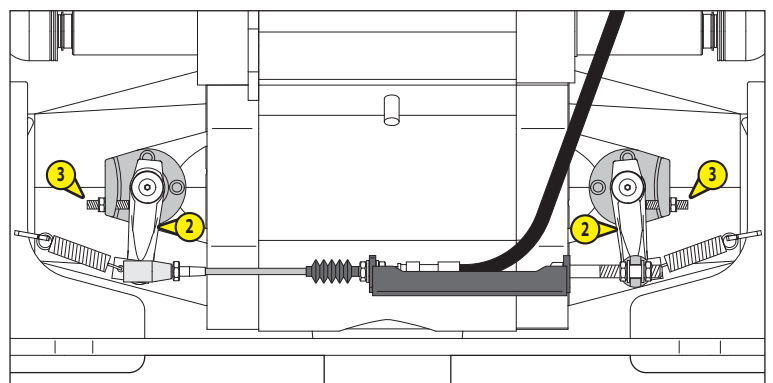

## REPLACE

## Engine oil

### REPLACE

### Engine oil filter

Place the lift truck on level ground, let the engine run at idling speed for a few minutes, then stop the engine.

#### **⚠ IMPORTANT ⚠**

*Dispose of the drain oil in an ecological manner.*

*Tighten the oil filter by hand pressure only and lock the filter in place by a quarter turn.*

#### DRAINING THE OIL

- Open the engine cover.
- Remove access panels 1 and 2.

NOTE: When removing cover plates and hatches, clean the surrounding area and remove any accumulations of flammable materials.

- Place a container under access panel 2.
- Unscrew the drain plug 3.
- Take drain hose 4.
- Place the end of the drain hose in the container and screw the hose fully to the drain connector 3.
- Remove the filler plug 5 to ensure correct drainage.

#### REPLACEMENT OF THE FILTER

- Unscrew and discard the engine oil filter 6, together with its seal.
- Clean the filter bracket with a clean, lint-free cloth.
- Lightly oil the seal before refitting the new oil filter (⚠ FILTER CARTRIDGES AND BELTS) on its bracket (tightening torque 15 - 17 N.m).

#### FILLING WITH OIL

- Remove, clean and refit drain hose 4.
- Refit and tighten the drain plug 3.
- Fill up with oil (⚠ LUBRICANTS AND FUEL) through filler hole 5.
- Wait a few minutes to allow the oil to flow into the sump.
- Start the engine and let it run for a few minutes.
- Check for possible leaks from the drain plug and the oil filter.
- Stop the engine, wait a few minutes and check the correct level between the two marks on the dipstick 7.
- Top up the level if necessary.
- Refit access panels 1 and 2.



## REPLACE

## Hydrostatic transmission oil filter cartridge

Stop the engine on horizontal ground and place the forward/reverse selector in neutral.

#### **⚠ IMPORTANT ⚠**

*Thoroughly clean the outside of the filter and its surroundings before any intervention in order to prevent any risk of polluting the hydrostatic circuit.*

*Tighten the body of the filter by hand pressure only and lock the body of the filter in place by a quarter turn.*

- Place a container under the hydrostatic transmission oil filter 1.
- Unscrew the body of the filter.
- Remove the hydrostatic transmission oil filter cartridge and replace with a new one (⚠ FILTER CARTRIDGES AND BELTS).
- Make sure that the cartridge is correctly positioned and refit the body of the filter.



## REPLACE

## Front axle differential oil

Place the lift truck on level ground with the engine stopped and the still warm differential oil.

### ⚠ IMPORTANT ⚠

*Dispose of the drain oil in an ecological manner.*

- Place a container under drain plugs 1 and unscrew them.
- Remove level plug 2 and filling plug 3 to ensure that the oil is drained properly.
- Refit and tighten the drain plugs 1 (tightening torque 34 - 49 N.m).
- Fill up with oil (↩ LUBRICANTS AND FUEL) through filler hole 3.
- The level is correct when the oil level is flush with the edge of opening 2.
- Check for any possible leaks at the drain plugs.
- Refit and tighten level plug 2 (tightening torque 34 - 49 N.m) and filling plug 3 (tightening torque 34 - 49 N.m).

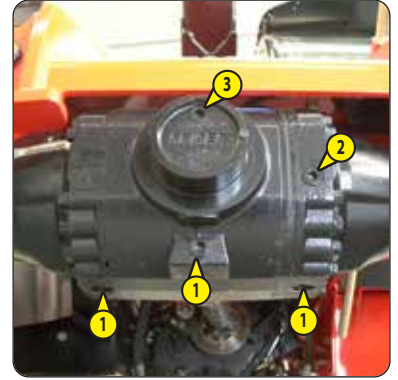

## REPLACE

## Hydraulic return oil filter cartridge

## REPLACE

## Hydraulic oil tank breather

Stop the engine and release the pressure from the systems by operating the hydraulic controls.

### ⚠ IMPORTANT ⚠

*Thoroughly clean the outside of the filter and its surroundings before any operation to prevent any risk of polluting the hydraulic system.*

*Tighten the body of the filter by hand pressure only and lock the body of the filter in place by a quarter turn.*

- Place a container under hydraulic return oil filter 1.
- Unscrew the filter cover 2 by two or three thread turns.
- Wait a few moments while the oil flows into the container.
- Remove the cover and slowly take out filter cartridge assembly.
- Place the assembly in a clean container.
- Pinch the head 4 and separate it from the tank 5.
- Replace the cartridge 6 with a new one (↩ FILTER CARTRIDGES AND BELTS).
- Make sure that the cartridge is correctly positioned.
- Refit the head 4 on the tank 5.
- Put back the assembly then retighten the filter cover 3.
- Refit a new filler plug 6 (↩ FILTER CARTRIDGES AND BELTS).



**EXTERNAL CAB VENTILATION FILTER**

- Remove protective casing 1 using the ignition key.
- Remove the cab ventilation filter 2 and replace it with a new one (⇐ FILTER CARTRIDGES AND BELTS).
- Refit the protective casing.



**INTERNAL CAB VENTILATION FILTER**

- Remove the protective grid 3.
- Remove the cab ventilation filter 4 and replace it with a new one (⇐ FILTER CARTRIDGES AND BELTS).
- Refit the protective grid.



**REPLACE**

**Filter coupling (OPTIONAL Automatic central greasing)**

- Switch off the lift truck's ignition.
- Remove the filter coupling 1 from the greasing unit.
- Clean the hole in the unit with a clean rag.
- Fit the new filter coupling to the unit (⇐ FILTER CARTRIDGES AND BELTS).
- Top up with grease if required.



**CHECK**

**Fork wear \***

*\* Consult your dealer.*

## 🔁 1000H - PERIODIC SERVICE - EVERY 1,000 HOURS OF SERVICE OR 2 YEARS

ALSO PERFORM THE 500 HOUR PERIODIC MAINTENANCE OPERATIONS.

### CHECK

### Seat belt

#### ⚠️ IMPORTANT ⚠️

*Under no circumstances must the lift truck be used if the seat belt is defective (fixing, locking, cuts, tears, etc.).  
Immediately repair or replace the seat belt.*

#### SEAT BELT WITH TWO ANCHORING POINTS

- Check the following points:
  - Fixing of the anchoring points on the seat.
  - Cleanness of the strap and the locking mechanism.
  - Triggering of the locking mechanism.
  - Condition of the strap (cuts, curled edges).

#### REELED SEAT BELT WITH TWO ANCHORING POINTS

- Check the points listed above together with the following points:
  - The correct winding of the belt.
  - Condition of the reel guards.
  - Roller locking mechanism when the strap is given a sharp tug.

NOTE: After an accident, replace the seat belt.

### CLEAN

### "Stationary lift truck" exhaust sublimation

#### ⚠️ IMPORTANT ⚠️

*Exhaust sublimation is an automated procedure activated by the operator when the following indicator lamps blink:  or  +  after 50 hours of operation with a 25% engine speed reduction.*

- Park the lift truck in a safe and adequately ventilated place.
- Check the following points:
  - forward/reverse selector in neutral,
  - parking brake applied,
  - no action on the hydraulic control joystick,
  - boom in transport position,
  - accelerator pedal released,
  - hand throttle not used (OPTION),
  - engine hood closed.
- Check that there are no foreign bodies or greasy deposits in the engine compartment, especially in the exhaust line.
- Check that the fuel level is sufficient.
- Start the lift truck and run the engine for a few minutes to bring it up to its operating temperature (60°C).
- Press down on the  bottom to start the exhaust sublimation procedure.
- The beginning of the procedure is confirmed by a continuously lit indicator lamp.
- Follow the steps described on the information screen.

#### ⚠️ IMPORTANT ⚠️

*The exhaust sublimation procedure must only be stopped if absolutely necessary.*

*The procedure stops automatically if the operator:*

- *activates the hydraulic control joystick,*
- *engages forward or reverse gear,*
- *switches off the engine,*
- *presses button .*

- The length of the exhaust sublimation procedure varies (between 30 and 45 minutes).

## CLEAN

### REPLACE

## Fuel tank

### Fuel tank breather

Place the lift truck on level ground with the engine stopped.

#### ⚠ IMPORTANT ⚠

*While carrying out these operations, do not smoke or work near a flame.*

*Never try to carry out a weld or any other operation by yourself, this could provoke an explosion or a fire.*

- Inspect the parts of the fuel circuit and the tank liable to leak, both visually and by touch.
- In the event of a leak, contact your dealer.
- Place a container under drain plug 1 and unscrew the plug.
- Remove the filler plug 2 to ensure correct drainage.
- Rinse with ten litres of clean diesel through filler hole 3.
- Refit and tighten the drain plug 1 (tightening torque 29 - 39 N.m).
- Unscrew the breather 4 and replace with a new one (↩ FILTER CARTRIDGES AND BELTS) (tightening torque 3 - 7 N.m).
- Fill the fuel tank with clean diesel filtered through the filler port.
- Refit the filler plug.



## REPLACE

## Coolant

These operations are to be carried out as necessary or every 2 years at the beginning of winter. Place the lift truck on level ground with the engine stopped and cold.

#### ⚠ IMPORTANT ⚠

*The engine does not contain any anti-corrosion elements and must be filled throughout the year with a mixture containing 25% ethylene glycol-based antifreeze.*

### DRAINING THE LIQUID

- Open the engine cover.
  - Unscrew the thumbwheel 1 to lower the access panel 2.
- NOTE: When removing cover plates and hatches, clean the surrounding area and remove any accumulations of flammable materials.
- Place a container under radiator drain plug 3 and unscrew the plug.
  - Remove filler plug 4 from the expansion tank and fully open the heating control to ensure correct drainage.
  - Let the cooling circuit drain entirely while ensuring that the ports do not get clogged.
  - Check the condition of the hoses as well as the fastening devices and change the hoses if necessary.
  - Rinse the circuit with clean water and use a cleaning agent if necessary.

### FILLING WITH COOLANT

- Refit and tighten the radiator drain plug 3.
- Slowly fill the circuit with coolant (↩ LUBRICANTS AND FUEL) up to the middle of the expansion tank 5 by the filler hole.
- Refit the filler plug 4.
- Run the engine at idle for a few minutes.
- Check for any possible leaks.
- Refit access panel 2 and retighten the thumbwheel 1.
- Check the level and refill if necessary.



## REPLACE

## "DEF"(Diesel Exhaust Fluid) supply pump filter

Place the lift truck on level ground with the engine stopped.

### ⚠ IMPORTANT ⚠

*Diesel exhaust fluid is corrosive: protect the bodywork and wear personal protective equipment (gloves and goggles). Carefully clean the outside of the fuel filter, to prevent dust from getting into the system.*

- Switch off the lift truck's ignition and wait for the pump to stop.
- Unscrew the pump cover 1, remove the compensation element 2 and discard.
- Insert the extraction tool 3 (provided with the new filter) into the filter 4 until a click is heard or felt.
- Pull the tool to extract and discard the assembly.
- Lightly oil the cover joint with clean engine oil.
- Replace with a new filter and compensation element (⇐ FILTER CARTRIDGES AND BELTS) in the pump and screw the cover 1 (torque 23 N.m).

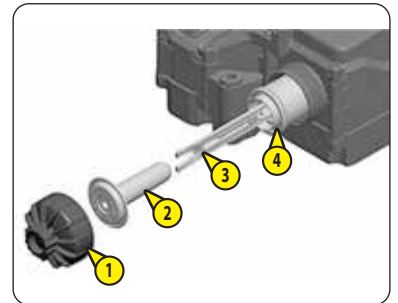

## REPLACE

## Dry air filter cartridge

In case of use in a heavily dust laden atmosphere, there are pre-filtration cartridges, (⇐ FILTER CARTRIDGES AND BELTS). Also, the checking and cleaning periodicity of the cartridge must be reduced (up to 250 hours in a very dusty atmosphere and with pre-filtration).

### ⚠ IMPORTANT ⚠

*Change the cartridge in a clean location, with the engine stopped. Never operate the lift truck with the air filter removed or damaged.*

- Open the engine cover.
- Loosen the locks and remove cover 1.
- Gently remove the cartridge 2 to reduce dust falling as far as possible.
- Leave the safety cartridge in place.
- Carefully clean the following parts with a damp, clean lint-free cloth.
  - The inside of the filter and cover.
  - The inside of the filter inlet hose.
  - The gasket surfaces in the filter and in the cover.
- Check pipes and connections between the air filter and the engine and the connection and state of the clogging indicator on the filter.
- Before fitting check the condition of the new cartridge (⇐ FILTER CARTRIDGES AND BELTS).
- Insert the cartridge in the filter axis and push the cartridge pressing against the outer edge and not the centre.
- Reassemble the cover, guiding the valve downwards.



## REPLACE

### Fuel pre-filter

#### **⚠ IMPORTANT ⚠**

*Carefully clean the outside of the pre-filter and its holder, to prevent dust from getting into the system.  
Tighten the fuel filter by hand only and lock in place by a quarter turn.*

- Switch off the lift truck's ignition.
- Open the engine cover.
- Close the fuel supply with valve 1.
- Disconnect electrical wiring harness 2 from the fuel pre-filter.
- Place a hose on the drain plug 3 and the other end in a container.
- Unscrew the drain plug 3 by two turns.
- Open bleed screw 4 to ensure proper emptying.
- Re-tighten bleed screw 4 once the pre-filter is emptied.
- Loosen pre-filter 5 and discard it, together with its seal.
- Clean the inside of the pre-filter head using a brush immersed in clean diesel oil.
- Refit a pre-filter and a new seal lubricated with clean diesel beforehand (↩ FILTER CARTRIDGES AND BELTS).
- Reconnect electrical wiring harness 2 on the fuel pre-filter.
- Replace the fuel filter.



## REPLACE

### Fuel filter

#### **⚠ IMPORTANT ⚠**

*Carefully clean the outside of the filter and its holder, to prevent dust from getting into the system.*

- Unscrew and discard the fuel filter 6.
- Clean the inside of the filter head using a brush immersed in clean diesel oil.
- Refit a filter and a new seal lubricated with clean diesel beforehand (↩ FILTER CARTRIDGES AND BELTS).
- Tighten the filter, making sure that the seal is correctly positioned (tightening torque 10 - 12 N.m).
- Open the fuel supply with valve 1.
- Open the bleed screw 4 of the fuel pre-filter and the bleed screw 7 of the fuel filter.
- Switch on the lift truck's ignition, and close the bleed screw as soon as the diesel flows with no air.



## REPLACE

### Reduction gearbox oil

Place the lift truck on level ground with the engine stopped and the reduction gearbox oil still warm.

#### **⚠ IMPORTANT ⚠**

*Dispose of the drain oil in an ecological manner.*

- Place a container under drain plug 1 and unscrew the plug.
- Remove level and filling plug 2 to ensure correct drainage.
- Refit and tighten the drain plug 1 (tightening torque 34 - 49 N.m).
- Fill up with oil (↩ LUBRICANTS AND FUEL) through filler hole 2.
- The level is correct when the oil level is flush with the edge of the hole.
- Check for any possible leaks at the drain plug.
- Refit and tighten the level and filling plug 2 (tightening torque 34 - 49 N.m).

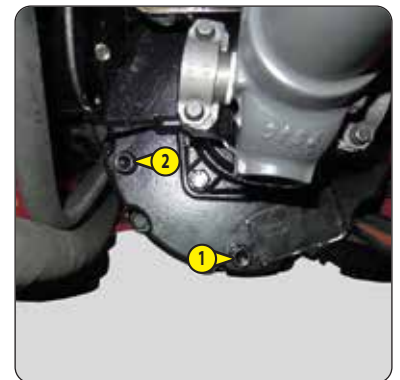

## REPLACE

### Rear axle differential oil

Place the lift truck on level ground with the engine stopped and the still warm differential oil.

#### **⚠ IMPORTANT ⚠**

*Dispose of the drain oil in an ecological manner.*

- Place a container under drain plugs 1 and unscrew them.
- Remove level plug 2 and filling plug 3 to ensure that the oil is drained properly.
- Refit and tighten the drain plugs 1 (tightening torque 34 - 49 N.m).
- Fill up with oil (⚡ LUBRICANTS AND FUEL) through filler hole 3.
- The level is correct when the oil level is flush with the edge of opening 2.
- Check for any possible leaks at the drain plugs.
- Refit and tighten level plug 2 (tightening torque 34 - 49 N.m) and filling plug 3 (tightening torque 34 - 49 N.m).

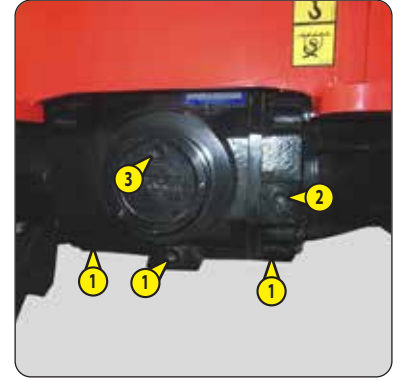

## REPLACE

### Front wheel reducer oil

## REPLACE

### Rear wheel reducer oil

Place the lift truck on level ground with the engine stopped and the reducers' oil still warm.

#### **⚠ IMPORTANT ⚠**

*Dispose of the drain oil in an ecological manner.*

- Drain and change the oil of each wheel reduction gear.
- Place drain plug 1 in position A.
- Place a container under the drain plug and unscrew the plug.
- Let the oil drain fully.
- Place the drain port in position B, i.e. in a level port.
- Fill up with oil (⚡ LUBRICANTS AND FUEL) through level hole 1.
- The level is correct when the oil level is flush with the edge of the hole.
- Refit and tighten the drain plug (tightening torque 34 - 49 N.m).



**CHECK** *Engine silent blocks \**

---

**CHECK** *Reduction gearbox silent blocks \**

---

**CHECK** *Boom pad wear \**

---

**CHECK** *Condition of wiring harnesses and cables \**

---

**CHECK** *Lights and signals \**

---

**CHECK** *Warning indicators \**

---

**CHECK** *Condition of the rear view mirrors \**

---

**CHECK** *Cabin structure \**

---

**CHECK** *Frame structure \**

---

**CHECK** *Attachment carriage \**

---

**CHECK** *Condition of attachments \**

---

*\* Consult your dealer.*

## 🔄 2000H - PERIODIC SERVICE - EVERY 2000 HOURS OF SERVICE OR 4 YEARS

ALSO PERFORM THE 500 HOUR AND 1,000 HOUR PERIODIC MAINTENANCE OPERATIONS.

### CHECK

- Check the condition of the tyres, to detect cuts, blisters, wear, etc.
- Check the tightening torque of the wheel nuts with a torque wrench:
  - Front wheels = 630 N.m ± 94 N.m
  - Rear wheels = 630 N.m ± 94 N.m

### Wheel nut tightening torques

### REPLACE

#### Dry air filter safety cartridge

#### ⚠ IMPORTANT ⚠

*The safety cartridge replacement frequency is given for information only. It must be changed every second time the dry air filter cartridge is changed.*

- For the dismantling and refitting of the cartridge (⏪ 1000H: REPLACE Air filter cartridge).
- Remove the dry air filter safety cartridge 1 carefully, to minimise dust fall.
- Clean the gasket surface on the filter with a damp, clean lint-free cloth.
- Check the condition of the new safety cartridge before fitting (⏪ FILTER CARTRIDGES AND BELTS).
- Insert the cartridge in the filter axis and push the cartridge pressing against the outer edge and not the centre.



### REPLACE

#### Alternator belt

- Open the engine cover.
- Remove the protective casing 1.

#### REMOVING THE BELT

- Place a 1/2 in. socket wrench in the square of the automatic tensioner 2.
- Turn the socket wrench anti-clockwise, and block the tensioner with a tool 3 (pin punch) to slacken and remove the belt.
- Remove the alternator belt 4.

NOTE: Take advantage of belt removal to check the correct operation of the pulleys and bearings (noise, rubbing, play, etc.).

#### REFITTING THE BELT

- Refit a new alternator belt (⏪ FILTER CARTRIDGES AND BELTS). Ensure that it is properly seated in the grooves of each pulley.
- Continue to apply force to the socket wrench, remove the tool 3 (pin punch) and release the force on the socket wrench.
- Check that the belt is correctly positioned.
- Refit the protective casing 1.

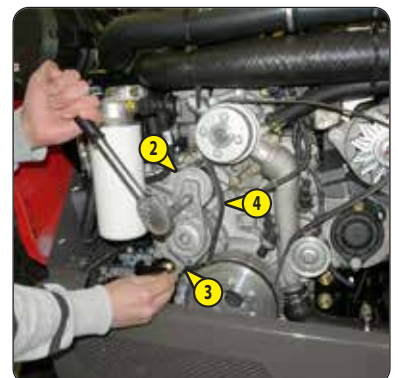

**REPLACE**

**Hydraulic oil**

**CLEAN**

**Hydraulic oil tank suction strainers**

**REPLACE**

**Ventilation control filter**

Place the lift truck on level ground with the engine shut down, and the boom retracted and lowered as far as possible.

**⚠ IMPORTANT ⚠**

*Before any intervention, thoroughly clean the area surrounding the filter, the drain plugs and the suction cover on the hydraulic tank.*

*Dispose of the drain oil in an ecological manner.*

*Use a very clean container and funnel and clean the underside of the oil drum before filling.*

**DRAINING THE OIL**

- Place a container under drain plugs 1 and unscrew them.
- Remove level and filling plug 2 to ensure that the oil is drained properly and discard.

**CLEANING OF STRAINERS**

- Remove the hoses 3.
- Remove and clean the suction strainers 4 using a compressed air jet, check their condition and replace if necessary (⇐ FILTER CARTRIDGES AND BELTS).
- Refit the strainers 4 and the hoses 3 ensuring their seals are correctly positioned.

**REPLACING THE VENTILATION CONTROL FILTER**

- Unscrew the filter 7 and replace it with a new one (⇐ FILTER CARTRIDGES AND BELTS).

**FILLING WITH OIL**

- Clean and refit the drain plugs 1 (tightening torque 29 - 39 N.m).
- Fill up with oil (⇐ LUBRICANTS AND FUEL) through filler hole 5.
- Observe the oil level on dipstick 6, the oil level should be at the level of the red dot.
- Check for any possible leaks at the drain plugs.



<b>CHECK</b>	<b>Radiator *</b>
<b>CHECK</b>	<b>Transmission pressures *</b>
<b>CHECK</b>	<b>Steering *</b>
<b>CHECK</b>	<b>Steering swivel joints *</b>
<b>CHECK</b>	<b>Condition of boom assembly *</b>
<b>CHECK</b>	<b>Bearings and bushings *</b>
<b>CHECK</b>	<b>Condition of hoses and flexible pipes *</b>
<b>CHECK</b>	<b>Condition of cylinders (leakage, rods) *</b>
<b>CHECK</b>	<b>Hydraulic circuit pressures *</b>
<b>CHECK</b>	<b>Bearings and bushings *</b>
<b>CLEAN</b>	<b>Air conditioning (OPTION) *</b>

#### CLEANING CONDENSER AND EVAPORATOR COILS

#### CLEANING CONDENSATE TRAY AND RELIEF VALVE

#### COLLECTING COOLANT TO REPLACE DRIER FILTER

#### REFILLING WITH COOLANT AND CHECKING THE THERMOSTATIC CONTROL AND PRESSURE SWITCHES

NOTE: When opening the evaporator unit, remember to replace the cover seal.

#### **⚠ IMPORTANT ⚠**

**DO NOT ATTEMPT TO REPAIR ANY PROBLEMS YOURSELF. ALWAYS REFER TO YOUR DEALER WHEN REFILLING CIRCUITS, AS THEY HOLD THE CORRECT SPARE PARTS, AS WELL AS HAVING THE NECESSARY TECHNICAL KNOWLEDGE AND TOOLS.**

*In any of the following circumstances, call a doctor.*

*If inhaled, take the victim to fresh air.*

*If there is contact with the skin, wash immediately with plenty of water.*

*If there is frostbite, apply a sterile dressing.*

*If there is contact with the eyes, rinse with clear water for 15 minutes.*

#### IMPORTANT INFORMATION REGARDING THE COOLANT USED

- This product contains fluorinated greenhouse gases covered by the Kyoto Protocol.
- Coolant type: R134A; it is colourless and odourless and heavier than air. Its GWP (Global Warming Potential) is 1,430.
- Do not allow the gases to escape into the atmosphere. Do not open the circuit under any circumstances, as this could cause refrigerant to escape.
- The compressor has a fluid level gauge; never unscrew this gauge because it would depressurise the system. The fluid level should only be checked when draining the system.



**REPLACE**

**Compressor belt (air conditioning OPTION) \***

---

*\* Consult your dealer.*

## ↻ OCCASIONAL MAINTENANCE

### REPLACE

### Wheels

For this operation, we advise you to use the hydraulic jack (MANITOU part no.: 505507) and the safety support prop (MANITOU part no.: 554772).

#### ⚠ IMPORTANT ⚠

*In the event of a wheel being changed on the public highway, secure the lift truck vicinity:*

- Stop the lift truck, if possible on firm, level ground.
- Stop the lift truck (↩ 1 - OPERATING AND SAFETY INSTRUCTIONS: DRIVING INSTRUCTIONS UNLADEN AND LADEN).
- Switch on the hazard warning lights.
- Immobilise the lift truck in both directions on the axle opposite to the wheel to be changed.
- Unlock the nuts of the wheel to be changed.
- Place the jack under the flared axle tube, as near as possible to the wheel and adjust the jack.
- Raise the wheel until it is clear of the ground and place the safety support under the axle.
- Completely unscrew the wheel nuts and remove them.
- Free the wheel by reciprocating movements and roll it to the side.
- Slip the new wheel on the wheel hub.
- Hand-tighten the nuts, grease them if necessary.
- Remove the safety support and lower the lift truck with the jack.
- Tighten the wheel nuts with a torque wrench (↩ 2000H - PERIODIC SERVICE - EVERY 2,000 HOURS OF SERVICE OR EVERY 4 YEARS) for the tightening torque.



### REPLACE

### Battery

#### ⚠ IMPORTANT ⚠

*Switch off the ignition with the key, wait 30 seconds, then operate the battery cut-off.*

*Wait 5 minutes before disconnecting the battery, this is required in order to purge the Diesel Exhaust Fluid (DEF) system.*

*Handling and servicing a battery can be dangerous, take the following precautions:*

- Wear protective goggles.
- Keep the battery horizontal.
- Never smoke or work near a naked flame.
- Work in a well-ventilated area.

*- In the event of electrolyte being spilled onto the skin or splashed in the eyes, rinse thoroughly with cold water for 15 minutes and call a doctor.*

- Open the engine cover.
- Bring a backup battery of the same type as that of the lift truck, together with battery cables.
- Connect the back-up battery, respecting the polarity (-) (+).
- Start the lift truck and remove the cables as soon as the engine is running.

#### ⚠ IMPORTANT ⚠

*Raise the boom and place the boom safety wedge on the rod of the lifting cylinder (↩ 1 - INSTRUCTIONS AND SAFETY RECOMMENDATIONS: LIFT TRUCK MAINTENANCE INSTRUCTIONS).*

- Remove the protective casing 1.
- Replace the battery

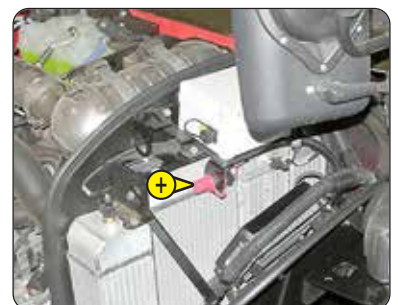

## ADJUST

## Front headlights

### RECOMMENDED SETTING

(according to standard ECE-76/756 76/761 ECE20)

Adjustment of -2% of the dipped beam harness relative to the horizontal axis of the headlight.

### ADJUSTMENT PROCEDURE

- Place the unladen lift truck in the transport position and perpendicular to a white wall on flat, level ground.
- Check the tyre pressures (↖ 2 - DESCRIPTION: TYRES).
- Place the forward/reverse selector in neutral.

### CALCULATING THE HEIGHT OF THE DIPPED BEAM (H2)

- h1 = Height of the dipped beam in relation to the ground.
- h2 = Height of the adjusted beam.
- l = Distance between the dipped beam and the white wall.

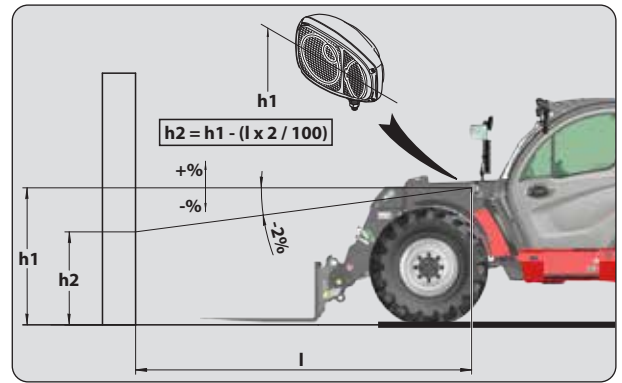

## RESET

## Longitudinal stability limiter and warning device

According to the use of the lift truck, the device may require to be periodically reset.

This operation can be easily performed by means of the following procedure.

- Provide a fork carrier or a bucket and a load corresponding to at least half the lift truck's rated capacity.
- Preferably perform the reset when the lift truck is still cold (before it is used) or ensure that the temperature of the rear axle is not more than 50 °C.

### ⚠ IMPORTANT ⚠

*Carefully follow the boom positioning instructions.*

*When the reset is completed, check the operation of the longitudinal stability limiter and warning device (↖ 10H - DAILY SERVICE OR EVERY 10 HOURS OF SERVICE).*

*If in doubt, contact your dealer.*

- Place the lift truck on flat, level ground with the wheels straight.
- Press button B to display the "PREFERENCE" menu
- Turn knob A to navigate through the menus and sub-menus.

HYDRAULICS > STABILITY REBALANCING

- Press knob A to confirm.
- Follow the steps described on the information screen (OK = press button A).



#### ⚠ IMPORTANT ⚠

*This operation must be performed at very low speed (less than 5 km/h) and over as short a distance as possible (less than 100 m).  
The high pressure limiters **MUST** be unlocked to avoid damaging the hydrostatic transmission.*

#### UNLOCKING THE HIGH PRESSURE LIMITERS

- Remove the cover plate 1.

NOTE: When removing cover plates and hatches, clean the surrounding area and remove any accumulations of flammable materials.

- Remove the caps 2 from each limiter.
- Unscrew the screws 3 by two turns to the left.

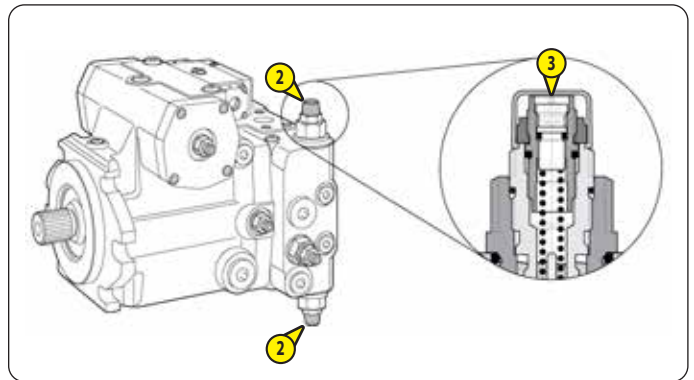

- Switch on lift truck ignition.
- Set the forward/reverse selector to neutral.
- Release the hand brake.
- Switch on the hazard warning lights.
- Remove the clip 4, lift the towing pin 5 and place the tow bar or the winch cable on the towing pin.

NOTE: Since there will be no steering or braking hydraulic assistance, operate the steering and pedal slowly avoiding sudden or jerky movements.

- After towing, re-tighten screws 3 (tightening torque 9 - 10 N.m).
- Refit the caps 2.



## SLING

## Lift truck

- Take into account the position of the lift truck centre of gravity for lifting.

A = 1417 mm      B = 1273 mm      MLT 630 ...

A = 1315 mm      B = 1375 mm      MLT 730 ...

- Place the hooks in the fastening points 1 provided.

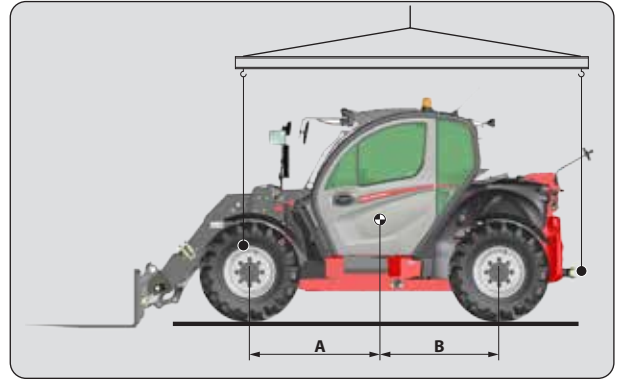

**⚠ IMPORTANT ⚠**

Ensure that the safety instructions associated with the flatbed are complied with before loading the lift truck and that the driver of the carrier vehicle is informed of the dimensions and the weight of the lift truck (<math>\leq 2</math> - DESCRIPTION: CHARACTERISTICS).

Ensure that the platform is of sufficient size and load capacity for transporting the lift truck. Check also the allowable ground contact pressure of the platform relative to the lift truck.

**⚠ IMPORTANT ⚠**

For lift trucks equipped with a turbo-charged engine, block off the exhaust outlet to avoid rotation of the turbo shaft without lubrication when transporting the vehicle.

**LOADING THE LIFT TRUCK**

- Block the wheels of the platform.
- Attach the loading ramps to the platform in such a way as to give the shallowest possible ramp angle for the lift truck.
- Load the lift truck parallel to the platform.
- Stop the lift truck (<math>\leq 1</math> - OPERATING AND SAFETY INSTRUCTIONS: DRIVING INSTRUCTIONS UNLADEN AND LADEN).

**STOWING THE LIFT TRUCK**

- Fix the chocks to the platform at the front and at the back of each tyre.
- Also fix the chocks to the platform on the inside of each tyre.
- Secure the lift truck to the platform with sufficiently strong ropes to the anchoring points 1 provided.
- Tighten the ropes.

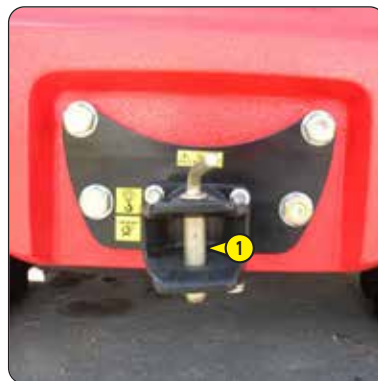
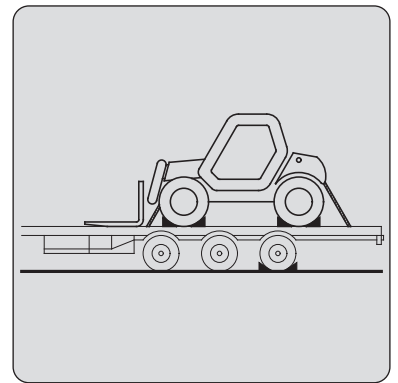
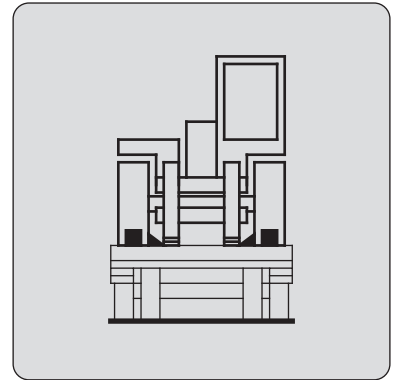
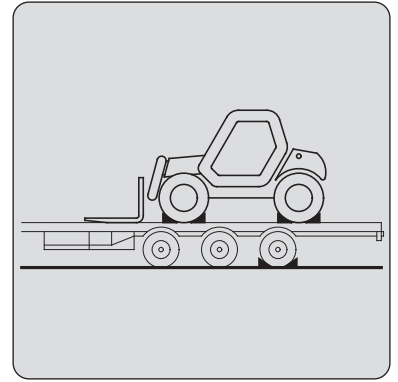

# ***4 - OPTIONAL ADAPTABLE ATTACHMENTS FOR THE RANGE***



## 4 - OPTIONAL ADAPTABLE ATTACHMENTS FOR THE RANGE

<u>INTRODUCTION</u>	4-3
<u>PICKING UP THE ATTACHMENTS</u>	4-4
<u>TECHNICAL SPECIFICATIONS OF ATTACHMENTS</u>	4-6
<u>ATTACHMENT GUARDS</u>	4-12

### INTRODUCTION

- Your lift truck must be used with interchangeable equipment. These items are called: ATTACHMENTS.
- A wide range of attachments is available, guaranteed by MANITOU and designed to fit your lift truck perfectly.

#### **⚠ IMPORTANT ⚠**

*Only attachments approved by MANITOU can be used with their lift trucks (↪ TECHNICAL SPECIFICATIONS OF ATTACHMENTS).  
The manufacturer cannot be held responsible for any modifications or adaptations to attachments without its knowledge.*

- The attachments are delivered with a load chart concerning your lift truck. The operator's manual and the load chart should be kept in the places provided in the lift truck. For standard attachments, their use is governed by the instructions contained on this notice.

#### **⚠ IMPORTANT ⚠**

*Maximum loads are defined by the capacity of a lift truck taking account of the attachment's mass and centre of gravity.  
Should the attachment have a lower capacity than the lift truck, never exceed this limit.*

- Some particular uses require the adaptation of the attachment which is not provided in the price-listed options. Optional solutions exist, consult your dealer.

#### **⚠ IMPORTANT ⚠**

*Depending on their size, certain attachments may, when the boom is lowered and retracted, come into contact with the front tyres and cause damage to them if excavation is activated in the direction of the discharge.*

**TO PREVENT THIS RISK, EXTEND THE TELESCOPE TO A SUFFICIENT EXTENT FOR THE PARTICULAR LIFT TRUCK AND ATTACHMENT SO THAT THIS CONTACT IS NOT POSSIBLE.**

### SUSPENDED LOAD

#### **⚠ IMPORTANT ⚠**

*Suspended loads **MUST** be handled with a lift truck designed for that purpose (↪ 1 - OPERATING AND SAFETY INSTRUCTIONS: LOAD HANDLING INSTRUCTIONS: H - PICKING UP AND PUTTING DOWN A SUSPENDED LOAD).*

## PICKING UP THE ATTACHMENTS

### 1 - ATTACHMENT WITHOUT HYDRAULICS AND HAND LOCKING DEVICE

#### FITTING AN ATTACHMENT

- Ensure that the attachment is in a position facilitating the locking to the carriage. If it is not correctly oriented, take the necessary precautions in order to move it safely.
- Check that the locking pin is in position in the bracket (fig. A).
- Place the lift truck with the boom lowered in front of and parallel to the attachment, and tilt the carriage forwards (fig. B).
- Bring the carriage under the locking tube of the attachment, slightly raise the boom, tilt the carriage backwards in order to position the attachment (fig. C).
- Lift the attachment off the ground to facilitate locking.

#### MANUAL LOCKING

- Take the locking pin on the bracket (fig. A) and lock the attachment (fig. D). Do not forget to fit the cotter pin.

#### MANUAL UNLOCKING

- Proceed in the reverse order to MANUAL LOCKING, taking care to refit the locking pin in the bracket (fig. A).

#### REMOVING THE ATTACHMENT

- Proceed in the reverse order to FITTING AN ATTACHMENT, taking care to store the attachment flat on the ground and in the closed position.

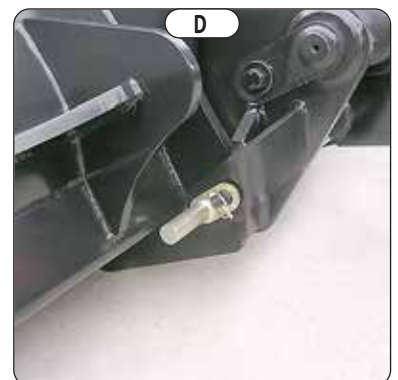
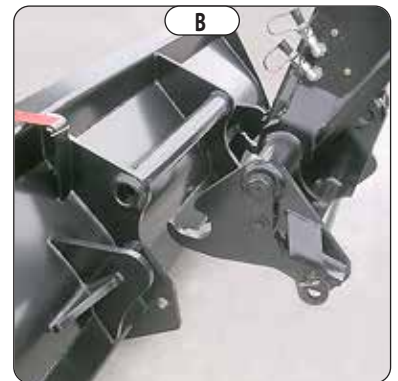
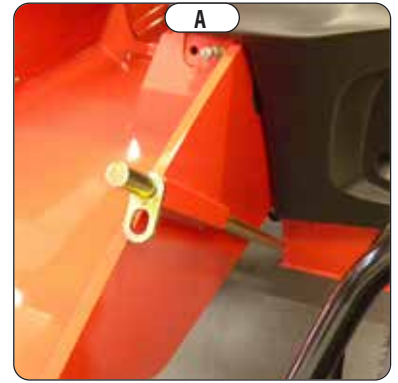

## 2 - HYDRAULIC ATTACHMENT AND MANUAL LOCKING DEVICE

### FITTING AN ATTACHMENT

- Ensure that the attachment is in a position facilitating the locking to the carriage. If it is not correctly oriented, take the necessary precautions in order to move it safely.
- Check that the locking pin is in position in the bracket (fig. A).
- Place the lift truck with the boom lowered in front of and parallel to the attachment, and tilt the carriage forwards (fig. B).
- Bring the carriage under the locking tube of the attachment, slightly raise the boom, tilt the carriage backwards in order to position the attachment (fig. C).
- Lift the attachment off the ground to facilitate locking.

### MANUAL LOCKING AND CONNECTION OF THE ATTACHMENT

#### ⚠ IMPORTANT ⚠

*Make sure that the rapid connectors are clean and protect the holes which are not used, with the caps provided.*

- Take the locking pin on the bracket and lock the attachment (fig. D). Do not forget to fit the cotter pin.
- Stop the engine and keep the ignition on the lift truck.
- Release the pressure in the attachment hydraulic circuit by operating switch 1 on the distributor lever backwards and forwards 4 or 5 times.
- Connect the quick-release couplers according to the logic of the attachment's hydraulic movements.

### MANUAL RELEASE AND DISCONNECTION OF THE ATTACHMENT

- Proceed in the reverse order of paragraph MANUAL LOCKING AND CONNECTION OF THE ATTACHMENT, taking care to refit the locking pin in the bracket.

### REMOVING THE ATTACHMENT

- Proceed in the reverse order to FITTING AN ATTACHMENT, taking care to store the attachment flat on the ground and in the closed position.

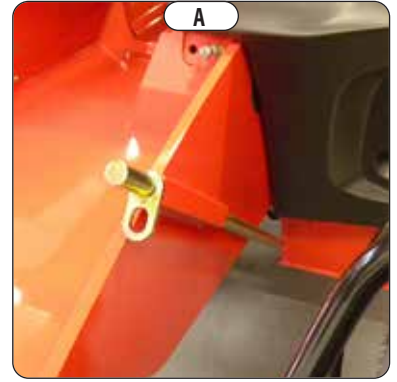

## TECHNICAL SPECIFICATIONS OF ATTACHMENTS

### STANDARDIZED TILTING FORK CARRIAGE

	PFB 35 N MT-1260 S2	PFB 35 N MT-1470 S2	PFB 35 N MT-1580 S2
<b>PART NO.</b>	<b>653744</b>	<b>653745</b>	<b>653746</b>
Rated capacity	3500 kg	3500 kg	3500 kg
Width	1260 mm	1470 mm	1580 mm
Weight	95 kg	120 kg	125 kg

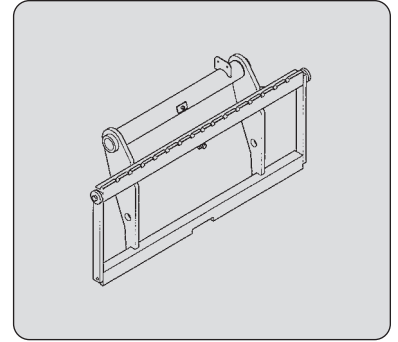

### STANDARDIZED FORK

	<b>PART NO.</b>	<b>415618</b>
Section		125x45x1200 mm
Weight		72 kg

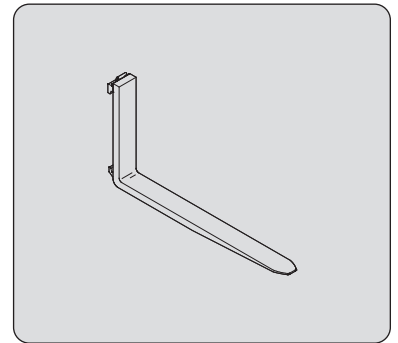

### STANDARDIZED TILTING FORK CARRIAGE + LOAD BACK REST

	PFB 35N 1260 LB	PFB 35N 1470 LB
<b>PART NO.</b>	<b>52000200</b>	<b>52000201</b>
Rated capacity	3500 kg	3500 kg
Width	1260 mm	1470 mm
Weight	130 kg	158 kg

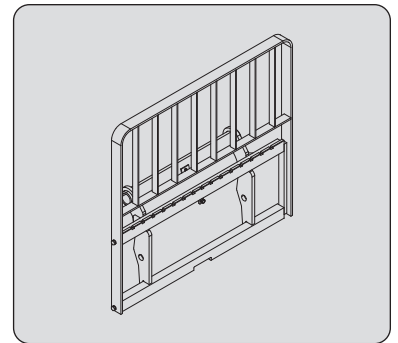

### FLOATING FORK CARRIAGE

	TFF 35 MT-1040	TFF 35 MT-1300
<b>PART NO.</b>	<b>654093</b>	<b>654094</b>
Rated capacity	3500 kg	3500 kg
Width	1040 mm	1300 mm
Weight	300 kg	340 kg

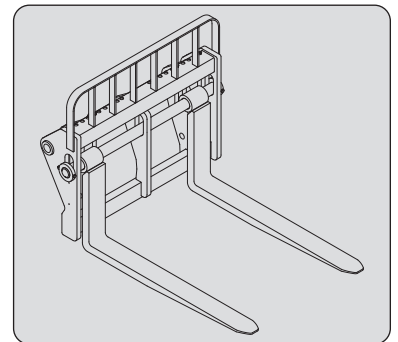

### FLOATING FORK

	<b>PART NO.</b>	<b>415801</b>
Section		125x45x1200 mm
Weight		68 kg

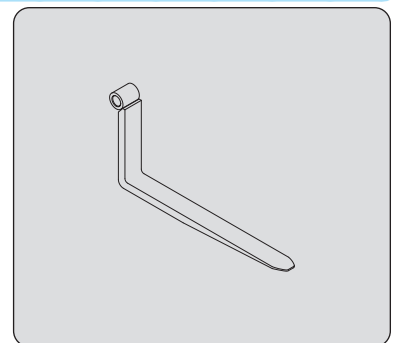

## BUCKET WITH GRAB

	<b>CBG 2100 MS</b>	<b>CBG 2300 MS</b>	<b>CBG 2450 MS</b>
<b>PART NO.</b>	<b>790304</b>	<b>790306</b>	<b>790308</b>
Rated capacity	1090 l	1190 l	1270 l
Width	2100 mm	2300 mm	2450 mm
Teeth	7	7	8
Weight	681 kg	720 kg	742 kg

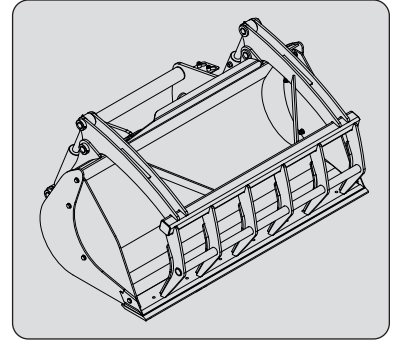

## BUCKET WITH GRAB

	<b>CBG 2100 FO</b>	<b>CBG 2300 FO</b>	<b>CBG 2450 FO</b>
<b>PART NO.</b>	<b>790305</b>	<b>790307</b>	<b>790309</b>
Rated capacity	1170 l	1280 l	1270 l
Width	2100 mm	2300 mm	2450 mm
Teeth	8	9	9
Weight	686 kg	728 kg	750 kg

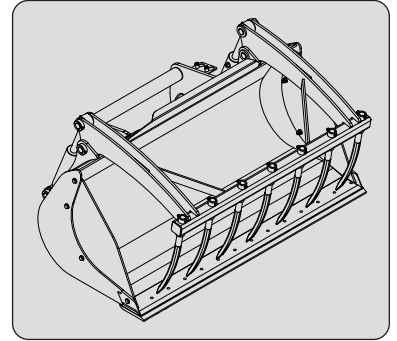

## SPREADER GRAB SHELL

	<b>CGD 2200/2100 FO</b>
<b>PART NO.</b>	<b>790311</b>
Rated capacity	2100 l
Width	2200 mm
Teeth	11
Weight	1140 kg

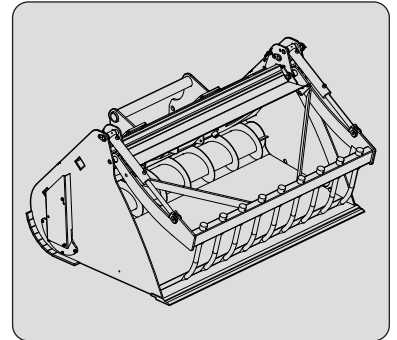

## SILAGE UNLOADING SHOVEL BUCKET

	<b>SHG 1800/1350</b>
<b>PART NO.</b>	<b>52000381</b>
Rated capacity	1315 l
Width	1800 mm
Weight	749 kg

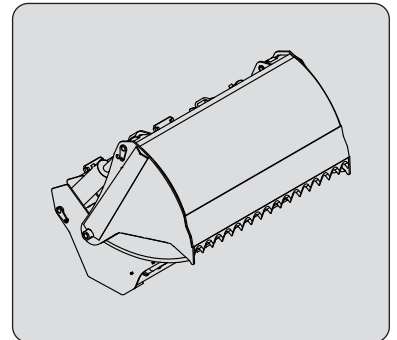

## MANURE FORK WITH GRAB

	<b>FFGR 30 MT 1950 S5</b>	<b>FFGR 30 MT 2100 S5</b>
<b>PART NO.</b>	<b>751404</b>	<b>751403</b>
Rated capacity	1580 Kg	1700 Kg
Width	1950 mm	2100 mm
Finger	9	10
Teeth	7	7
Weight	477 kg	492 kg

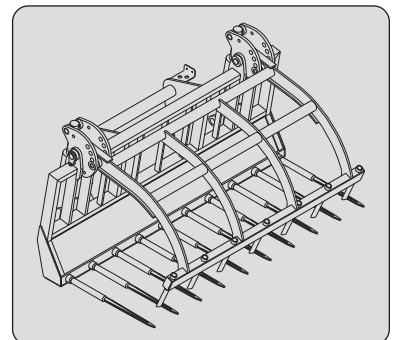

## GRAIN BUCKET

	<b>CBA 1700 L2100 S3</b>	<b>CBA 2000 L2250 S3</b>	<b>CBA 2000 L2450 S3</b>
<b>PART NO.</b>	<b>570549</b>	<b>790540</b>	<b>570551</b>
Rated capacity	1703 l	1970 l	2010 l
Width	2100 mm	2250 mm	2450 mm
Weight	522 kg	585 kg	567 kg

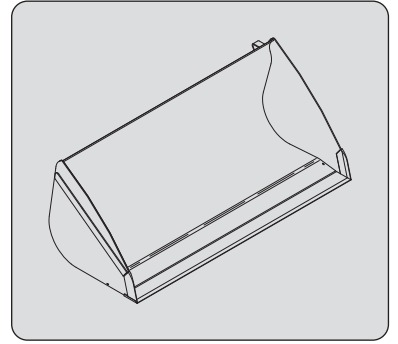

## FARMING BUCKET (REMOVABLE AND REVERSIBLE BLADE)

	<b>CBA 2000 L2250 LDR S3</b>	<b>CBA 2000 L2450 LDR S3</b>
<b>PART NO.</b>	<b>790541</b>	<b>570552</b>
Rated capacity	1970 l	2010 l
Width	2250 mm	2450 mm
Weight	625 kg	678 kg

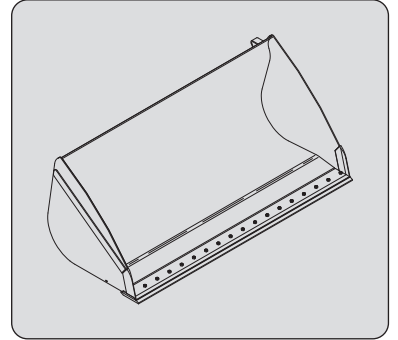

## BUILDING BUCKET

	<b>CBC 750 L2100</b>	<b>CBC 800 L2250</b>
<b>PART NO.</b>	<b>654475</b>	<b>654471</b>
Rated capacity	768 l	814 l
Width	2100 mm	2250 mm
Weight	345 kg	366 kg

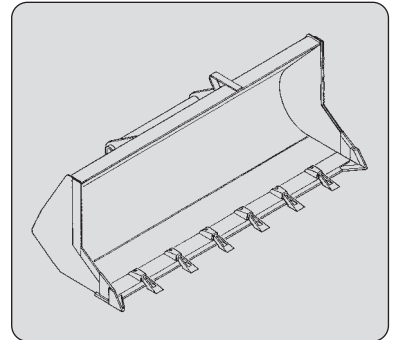

## LOADING BUCKET

	<b>CBR 850 L2100</b>	<b>CBR 900 L2250</b>
<b>PART NO.</b>	<b>653047</b>	<b>653749</b>
Rated capacity	778 l	904 l
Width	2100 mm	2250 mm
Weight	358 kg	360 kg

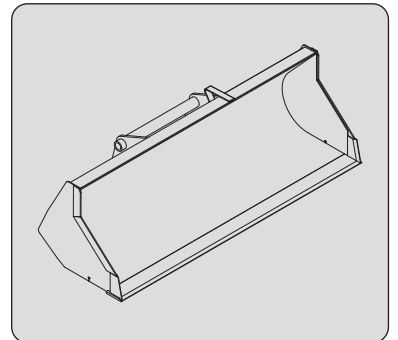

## BALE CLAMP

<b>PART NO.</b>	<b>PBG 2X2</b> <b>757639</b>
Rated capacity	800 kg
Width	1090 mm
Teeth	2x2
Weight	158 kg

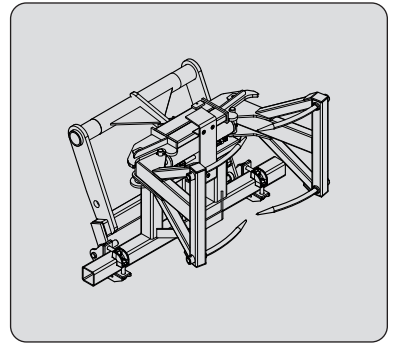

## BALE CLAMP

<b>PART NO.</b>	<b>PBG 2X4</b> <b>757612</b>
Rated capacity	1000 kg
Width	1300 mm
Teeth	2x4
Weight	262 kg

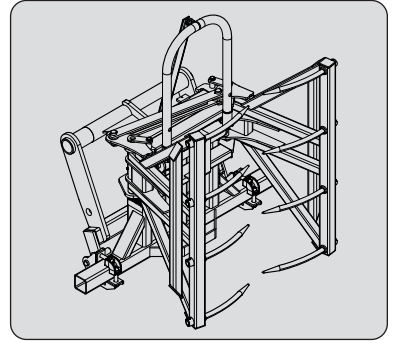

## BALE CLAMP

<b>PART NO.</b>	<b>P2BG 2X4</b> <b>790518</b>
Rated capacity	1500 kg
Width	1090 mm
Teeth	2x4
Weight	275 kg

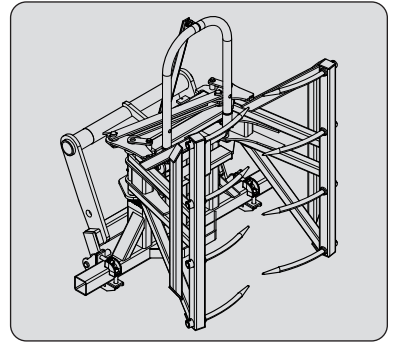

## BALE CLAMP

<b>PART NO.</b>	<b>MBC 2X3</b> <b>790506</b>
Rated capacity	800 kg
Width	1196 mm
Weight	290 kg

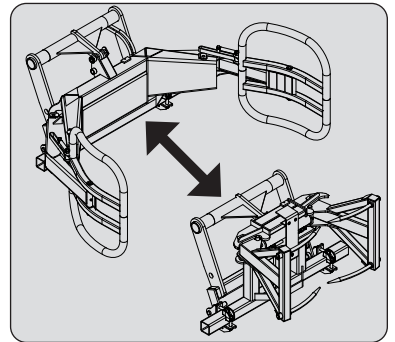

## BALE CLAMP

<b>PART NO.</b>	<b>PBE</b> <b>757613</b>
Rated capacity	1000 kg
Width	1600 mm
Weight	242 kg

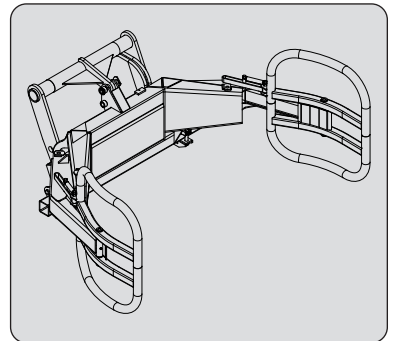

## BALE CLAMP

<b>PART NO.</b>	<b>P2BG 2X4</b> <b>790521</b>
Rated capacity	1700 kg
Width	1878 mm
Teeth	2
Weight	275 kg

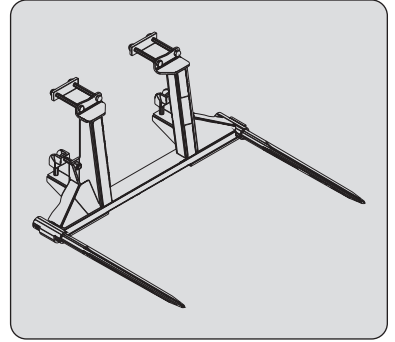

## BALE FORK

<b>PART NO.</b>	<b>FB 1900/1700</b> <b>790699</b>
Rated capacity	1700 kg
Width	1878 mm
Teeth	4
Weight	215 kg

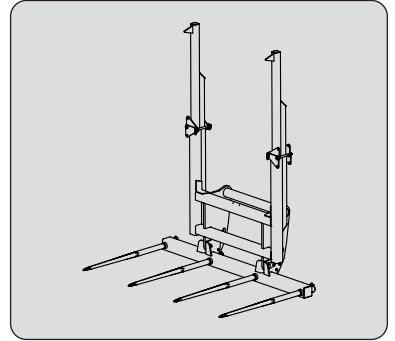

## JIB CRANE WITH BIG BAG

<b>PART NO.</b>	<b>HBB 1500/2400</b> <b>931627</b>
Rated capacity	2400 kg
Weight	186 kg

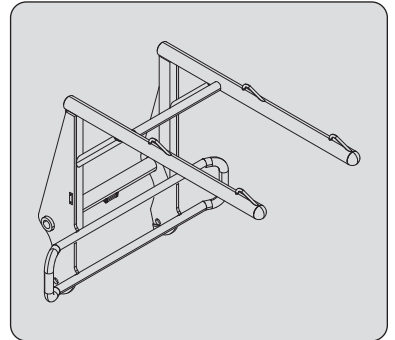

## JIB

<b>PART NO.</b>	<b>PC 50</b> <b>708544</b>
Rated capacity	5000 kg
Weight	120 kg

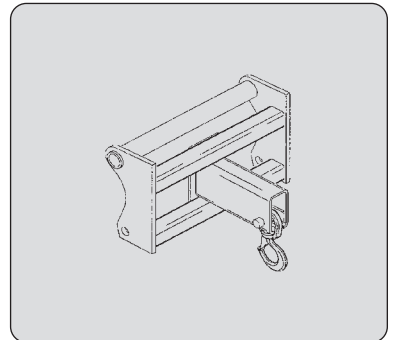

## SWEeper WITH BRUSH

<b>PART NO.</b>	<b>SCC 2600</b> <b>52000515</b>
Rated capacity	-
Width	2820 mm
Weight	755 kg

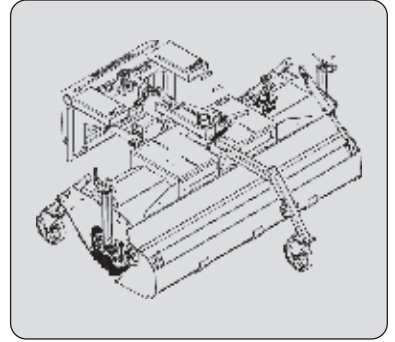

## SWEeper WITH BRUSH

<b>PART NO.</b>	<b>SCC 2600+</b> <b>52000517</b>
Rated capacity	-
Width	2820 mm
Weight	730 kg

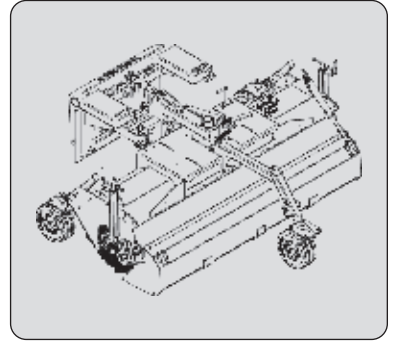

## SWEeper WITH BRUSH

<b>PART NO.</b>	<b>SCC 2600 HWA+</b> <b>52000519</b>
Rated capacity	120l
Width	2820 mm
Weight	800 kg

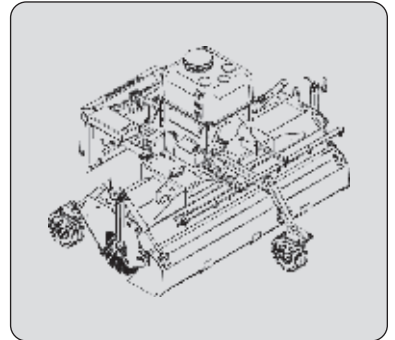

## HIGH PRESSURE SCRUBBER

<b>PART NO.</b>	<b>VHPC 600</b> <b>790335</b>
Rated capacity	600l
Width	1450 mm
Weight	240 kg

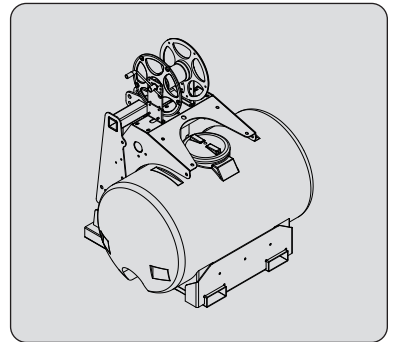

## JCB SINGLE CARRIAGE

<b>PART NO.</b>	<b>TS JCB Q FIT</b> <b>52560927</b>
Rated capacity	3000 Kg
Width	1230 mm
Weight	255 kg

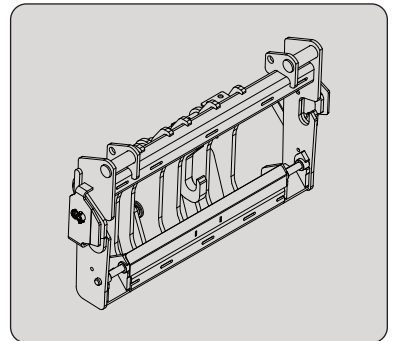

## ATTACHMENT GUARDS

### FORK GUARD

PART NO. 227801

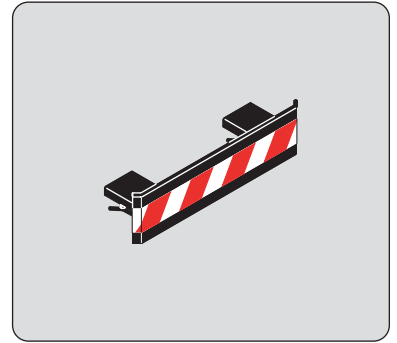

### FORK BLOCK FOR FLOATING FORK CARRIAGE

PART NO. 261210

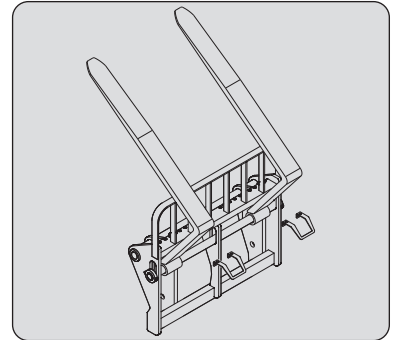

### BUCKET PROTECTOR

*Always ensure that the width of the protector you choose is less than or equal to the width of the bucket.*

	PART NO.	206734	206732	206730
Width		1375 mm	1500 mm	1650 mm
	PART NO.	235854	206728	206726
Width		1850 mm	1950 mm	2000 mm
	PART NO.	223771	223773	206724
Width		2050 mm	2100 mm	2150 mm
	PART NO.	206099	206722	223775
Width		2250 mm	2450 mm	2500 mm

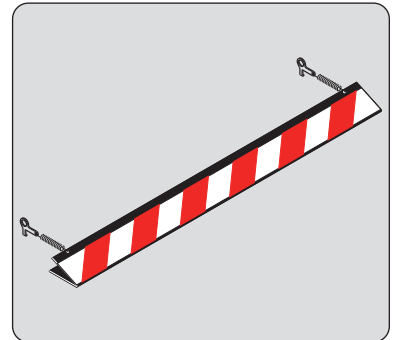

### MANURE FORK GUARD

PART NO. 230689

