



# **MANITOU**

## **HANDLING YOUR WORLD**

649290EN-USMG (D-11/2024)  
(GLOBAL)

OPERATOR'S MANUAL  
(ORIGINAL MANUAL)

MRT 1645 400 75D ST5 S1  
MRT 1645 400 115D ST5 S1  
MRT-X 1645 400 115D ST3A S1  
MRT 1845 400 75D ST5 S1  
MRT 1845 360 75D ST5 S1  
MRT 1845 400 115D ST5 S1  
MRT 1845 360 115D ST5 S1  
MRT-X 1845 400 115D ST3A S1  
MRT 2145 400 115D ST5 S1  
MRT 2145 360 115D ST5 S1  
MRT-X 2145 400 115D ST3A S1  
MRT 2545 400 115D ST5 S1  
MRT 2545 360 115D ST5 S1  
MRT-X 2545 400 115D ST3A S1



# CALIFORNIA PROPOSITION 65 WARNINGS & LEGAL DISCLAIMER

## California proposition 65 warnings

### ⚠ WARNING

#### Cancer and Reproductive Harm

This product can expose you to lead which is known to the State of California to cause cancer and birth defects or other reproductive harm.

For more information go to [www.P65Warnings.ca.gov](http://www.P65Warnings.ca.gov)

---

### ⚠ WARNING



#### Cancer and Reproductive Harm

Breathing diesel engine exhaust exposes you to chemicals known to the State of California to cause cancer and birth defects or other reproductive harm.

- Always start and operate the engine in a well-ventilated area.
- If in an enclosed area, vent the exhaust to the outside.
- Do not modify or tamper with the exhaust system.
- Do not idle the engine except as necessary.

For more information go to [www.P65Warnings.ca.gov](http://www.P65Warnings.ca.gov)

---

## Legal disclaimer

The brochure and all its contents, including diagrams, are the proprietary and confidential intellectual property of Manitou BF and / or its subsidiaries ("Manitou Group"). Any reproduction, publication or dissemination of any part of the brochure without the express written authorization of Manitou Group is strictly prohibited. Any violation of this provision will subject the offending party to prosecution by Manitou Group to the fullest extent of the law. The logos and the company's visual identity are the property of Manitou Group and may not be used without the express written authorization of Manitou Group. All trademarks, registered and unregistered, is and shall remain the property of Manitou BF or its respective owner.

Any reproduction, source code access, decompilation, modification, copy (other than backup copies), correction of errors, transmission or distribution of any software built into Manitou Group machines is strictly prohibited.

In the event that the measures above nevertheless prove essential to enable use of the software, in accordance with its destination, or to obtain the information required for interoperability with other software created independently, the user should contact Manitou Group in advance and Manitou may, at its sole discretion, take the necessary measures or give access to only the information strictly necessary for interoperability.

Any breach of these requirements is likely to constitute a counterfeiting offense subject to legal action by Manitou Group.

Connected Manitou Group machines are equipped with boxes that collect technical data on the machines (such as geo-tracking data or data on component operation). This data, which is organized, processed and enhanced by algorithms and expertise proprietary to Manitou Group, constitutes, in combination with other elements, independent or not, a protected database according to laws & regulations on IP purposes.

It is strictly forbidden to have access to all or part of this database and to use the data (including in the event of accidental access) without explicit prior authorization from Manitou Group. In the event that Manitou Group authorizes a Manitou Group machine user to access all or part of this database, Manitou Group, as producer of this database, cedes to the user only a right to personal, non-exclusive, non transferable use of the database, and only by access to an information technology platform hosted by a server owned or controlled by Manitou Group.

In any case, the following are strictly prohibited:

- any extraction, reproduction, representation, reuse through provision to the public, distribution, transfer, permanent or temporary, on any medium, by any means, and in any form whatsoever, of all or of a qualitatively or quantitatively substantial part of the contents of this database,
- any extraction, reproduction, representation, reuse through provision to the public, distribution, transfer, repeated or systematic of qualitatively or quantitatively insubstantial parts of the content of the database during operations manifestly exceeding normal use of the database by the user of the machine for his own needs,
- any use of means to bypass technical protection measures for databases or software source code embedded in the boxes, in keeping according to laws & regulations on IP purposes.

The latest updated version in force and binding of this document is the version available on demand.

Only the electronic version is maintained.

*MANITOU ITALIA S.r.l.*

*Via Cristoforo Colombo, 2 - 41013 - Castelfranco Emilia (MO) - Italy*

*Tel. +39 059 95 98 11*

[www.manitou-group.com](http://www.manitou-group.com)

<b>1</b>	<b>SAFETY .....</b>	<b>13</b>
1.1.	<b>ORIGINAL SPARE PARTS AND EQUIPMENT .....</b>	<b>13</b>
1.2.	<b>RECOMMENDATIONS FOR USE FOR THE DRIVER .....</b>	<b>13</b>
1.3.	<b>GENERAL INSTRUCTIONS .....</b>	<b>15</b>
1.3.1	Instruction Manual .....	15
1.3.2	Driving authorization .....	15
1.3.3	Routine maintenance .....	15
1.3.4	ENVIRONMENTAL CONDITIONS OF USE .....	15
1.3.5	VEHICLE CAB PROTECTION .....	16
1.4.	<b>DRIVING INSTRUCTIONS .....</b>	<b>16</b>
1.4.1	Driver seat provisions .....	16
1.4.2	Before starting the vehicle .....	17
1.4.3	Starting the vehicle .....	17
1.4.4	Telehandler guide .....	17
1.4.5	Stopping the vehicle .....	18
1.4.6	Driving the vehicle on the road .....	18
1.5.	<b>HANDLING INSTRUCTIONS .....</b>	<b>19</b>
1.5.1	Handling instructions .....	19
1.6.	<b>HANDLING OF A LOAD .....</b>	<b>21</b>
1.6.1	Load weight and center of gravity .....	21
1.6.2	Picking up a load from the ground .....	22
1.6.3	Pick up a load up on tires .....	23
1.6.5	Picking up a load without a pallet .....	24
1.6.6	Load status indicator device .....	25
1.7.	<b>INSTRUCTIONS FOR USING THE RADIO CONTROL .....</b>	<b>25</b>
1.7.1	Recommendations for using the remote control .....	25
1.8.	<b>TELEHANDLER MAINTENANCE INSTRUCTIONS .....</b>	<b>28</b>
1.8.1	Recommendations for maintenance .....	28
1.8.2	INSTRUCTIONS FOR TIRE MAINTENANCE .....	28
1.9.	<b>MAIN PARTS OF THE VEHICLE .....</b>	<b>29</b>
1.9.1	Main parts of the vehicle .....	29
1.10.	<b>INFORMATION FOR THE ENVIRONMENT .....</b>	<b>31</b>
1.10.1	RECYCLING OF MATERIALS .....	31
1.10.2	VEHICLE DISPOSAL .....	32
1.10.3	ENVIRONMENTAL PROTECTION .....	32
1.11.	<b>DECALS LOCATION .....</b>	<b>32</b>
1.11.1	Decals - Location .....	32
1.12.	<b>DECALS DESCRIPTION .....</b>	<b>37</b>
1.12.1	Decals - Warning Open-center valve system .....	37
1.12.2	Decal - Warning Prohibition to operators .....	37
1.12.3	Decal — Danger Vehicle controlled by remote control .....	38
1.12.4	Decal - Warning Risk of investment / crushing .....	38
1.12.5	Decal - Notice Wheel nuts tightening torque .....	38
1.12.6	Decal - Warning Pinch and nip points .....	38

1.12.7	Decal - Danger It is forbidden to climb/descend the stairs.....	39
1.12.8	Decal - Warning Safety locking device.....	39
1.12.9	Decal - Warning Moving parts.....	39
1.12.10	Decal - Warning Fan in operation.....	39
1.12.11	Decal - Warning pressurized fluid.....	40
1.12.12	Decal - Antifreeze fluid.....	40
1.12.13	Decal - Warning Pressurised system hot coolant.....	40
1.12.14	Decal - Caution Engine intake air filter.....	40
1.12.15	Decal - Danger Arc / Explosion.....	41
1.12.16	Decal - Electrocution hazard.....	41
1.12.17	Decal - Caution Battery.....	41
1.12.18	Decal - Diesel type.....	41
1.12.19	Decal - Danger Flammable liquids.....	42
1.12.20	Decal - Caution Battery master switch.....	42
1.12.21	Decal - DEF tank.....	42
1.12.22	Decal - Hydraulic oil level.....	42
1.12.23	Decal - Hydraulic oil tank.....	42
1.12.24	Decal - Notice high pressure washer.....	43
1.12.25	Decal - Explosion hazard.....	43
1.12.26	Decal - Caution It is forbidden to transport of people.....	43
1.12.27	Decal - Caution Fasten seat belt.....	43
1.12.28	Decal - Warning Risk of rollover.....	44
1.12.29	Decal - Caution Pressurized vessel.....	44
1.12.30	Decal - Caution No insulated platform.....	44
1.12.31	Decal - Use Manitou approved tyre only.....	44
1.12.32	Decal - Caution No go zone for power lines.....	45
1.12.33	Decal - Warning Hot surfaces.....	45
1.12.34	Decal - Notice Stabilizers pressure on the ground.....	45
1.12.35	Decal - Warning Transport of the vehicle.....	45
1.12.36	Decal - Forbidden cross the machine's working area.....	46
1.12.37	Decal - Diesel tank.....	46
1.12.38	Decal - Warning Maintain 3 points contact.....	46
1.12.39	Decal - Danger Boom safety wedge.....	46
1.12.40	Decal - Warning ROPS-FOPS Fitted Do not drill or weld.....	47
1.12.41	Decal - Jump Start (vehicle).....	47
1.12.42	Prohibition / obligation to lift the driving seat armrest.....	47
1.12.43	Decal - Black box system.....	47
1.12.44	Recharge of air conditioning system.....	47
1.12.45	Decal - Warning Crushing of hands.....	47

## **2 TECHNICAL DATA AND DESCRIPTION.....49**

<b>2.1. MACHINE IDENTIFICATION .....</b>	<b>49</b>
2.1.1 MANUFACTURER'S PLATE .....	49
2.1.2 VEHICLE IDENTIFICATION.....	49
2.1.3 HEAT ENGINE PLATE.....	49
2.1.4 HYDROSTATIC PUMP PLATE.....	49
2.1.5 HYDROSTATIC MOTOR PLATE.....	50
2.1.6 GEARBOX PLATE.....	51
2.1.7 CHASSIS PLATE.....	51

2.1.8	ACCESSORY MANUFACTURER'S PLATE.....	52
2.1.9	FRONT AXLE PLATE.....	52
2.1.10	REAR AXLE PLATE.....	52
2.1.11	CABIN PLATE .....	53
<b>2.2.</b>	<b>TECHNICAL SPECIFICATIONS .....</b>	<b>53</b>
2.2.1	EC declaration of conformity.....	53
2.2.2	UKCA declaration of conformity .....	55
2.2.3	55 kW engine .....	57
2.2.4	85 kW engine .....	74
2.2.5	CAPACITY AND LOAD CHARTS.....	138
<b>2.3.</b>	<b>ENVIRONMENT .....</b>	<b>144</b>
2.3.1	EXHAUST GAS AFTERTREATMENT SYSTEM (DOC/DPF+SCR) .....	144
<b>2.4.</b>	<b>COMPONENTS .....</b>	<b>158</b>
2.4.1	CONTROLS.....	158
2.4.2	Pedals and diagnosis sockets.....	159
2.4.3	ADJUSTABLE STEERING COLUMN LEVER .....	159
2.4.4	CONTROL LEVER FOR LIGHTS, HORN, INDICATOR LIGHTS AND WIPERS .....	160
2.4.5	USB PORT .....	161
2.4.6	SUNSHADE.....	161
2.4.7	DISPLAY HEIGHT ADJUSTMENT KNOB.....	162
2.4.8	Cabin accessories .....	162
2.4.9	Ceiling light and rear window opening lever .....	162
2.4.10	Opening the door and door window .....	163
2.4.11	DOOR WINDOW RELEASE LEVER FROM INSIDE CABIN.....	163
2.4.12	DOOR WINDOW RELEASE LEVER FROM OUTSIDE CABIN.....	163
2.4.13	Air diffusers .....	164
2.4.14	Registration plate.....	164
2.4.15	HEADLIGHTS .....	165
2.4.16	TAIL LIGHTS.....	165
2.4.17	Beacon and signal headlights .....	166
2.4.18	BATTERY DISCONNECT SWITCH.....	166
2.4.19	EMERGENCY STARTING.....	167
2.4.20	BOOM SAFETY WEDGE .....	167
<b>2.5.</b>	<b>OPERATOR AREA .....</b>	<b>168</b>
2.5.1	GETTING IN AND OUT OF THE VEHICLE.....	168
2.5.2	A - DRIVER'S SEAT (standard).....	168
2.5.3	B - PNEUMATIC SEAT FOR DRIVER ( <b>optional</b> ) .....	169
2.5.4	C - HEATED / VENTILATED DRIVER'S SEAT (optional).....	170
2.5.5	SEAT BELT .....	171
2.5.6	IGNITION SWITCH.....	171
2.5.7	"Easy MANAGER" ANTI-START SYSTEM (optional) .....	172
<b>2.6.</b>	<b>DISPLAY .....</b>	<b>172</b>
2.6.1	DISPLAY CONTROL .....	172
2.6.2	DISPLAY ICONS.....	173
2.6.3	DISPLAY PAGES .....	175
2.6.4	BUTTON BAR.....	177
2.6.5	MENU PAGES .....	180

2.6.6	"DRIVE" PAGE .....	180
2.6.7	"WORKING" PAGE .....	181
2.6.8	"STABILITY" PAGE .....	183
2.6.9	"ADJUSTMENTS" PAGE .....	183
2.6.10	"DIAGNOSTICS" PAGE .....	184
2.6.11	SETTINGS page .....	186
2.6.12	"RESOURCES" PAGE .....	192
2.6.13	"INFORMATION" PAGE .....	193
<b>2.7.</b>	<b>CHECK INDICATORS .....</b>	<b>194</b>
2.7.1	JOYSTICK .....	194
2.7.2	BUTTONS AND CONTROLS .....	195
2.7.3	SAFETY SYSTEM EXCLUSION KEY .....	199
2.7.4	RADIO CONTROL FOR ATTACHMENT MOVEMENT AND TELESCOPIC HANDLER MOVEMENT .....	199
2.7.5	REMOTE CONTROL "HMI" MONITOR .....	203
<b>2.8.</b>	<b>OPTIONAL .....</b>	<b>209</b>
2.8.1	AIR CONDITIONING .....	209
2.8.2	SIDE REAR-VIEW MIRRORS .....	210
2.8.3	BOOM SUSPENSION .....	210
2.8.4	HYDRAULIC BLOCK OF THE ATTACHMENT .....	211
2.8.5	ENGINE ECO STOP .....	212
2.8.6	HYDRAULIC ATTACHMENTS CONTINUOUS OPERATING MODE .....	213
2.8.7	SECOND HYDRAULIC OUTLET + HYDRAULIC BLOCK OF THE ATTACHMENT .....	214
2.8.8	FRONT AND SIDE CAMERA SYSTEM .....	215
2.8.9	LED WORK LIGHTS ON THE BOOM .....	216
2.8.10	REAR CABIN WORK LIGHTS .....	216
2.8.11	REAR CABIN WORK LIGHTS .....	217
2.8.12	BOOM ANGLE INDICATOR .....	217
2.8.13	INDICATION COLUMNS FOR CHECKING THE LOAD STATUS .....	218
2.8.14	12V electrical socket at the head of the boom .....	218
2.8.15	110V ELECTRIC SOCKET .....	219
2.8.16	220V ELECTRIC SOCKET .....	220
2.8.17	REAR ELECTRICAL SOCKET 7 POLES 24V FOR TRAILER .....	221
2.8.18	PREHEATING ELEMENT FOR ENGINE'S COOLANT FLUID 220 V .....	221
2.8.19	PREHEATING SYSTEM FOR HYDRAULIC OIL 220 V .....	223
2.8.20	WINDSHIELD PROTECTION GRILLE .....	225
2.8.21	WINDSHIELD PROTECTION GRILLE WITH ULTRA PANORAMIC VIEW ROOF .....	225
2.8.22	Interior rear-view mirror .....	225
2.8.23	ROAD CIRCULATION .....	226
2.8.24	PORTABLE POWDER FIRE EXTINGUISHER .....	226
2.8.25	INCREASED SUPPORT PLATFORMS FOR STABILIZERS .....	227
2.8.26	WHEEL CHOCKS .....	228
2.8.27	TOOL BAG FOR WHEEL DISASSEMBLY .....	228
2.8.28	TOOLBOX .....	229
<b>3</b>	<b>USE OF THE MACHINE .....</b>	<b>231</b>
<b>3.1.</b>	<b>BEFORE USING THE MACHINE .....</b>	<b>231</b>
3.1.1	PRE-USE INSPECTION CHECKLIST .....	231

3.1.2	Visibility .....	232
3.1.3	AREA AROUND THE VEHICLE .....	233
3.1.4	FILLING THE FUEL TANK.....	233
3.1.5	FILLING THE "DEF" TANK.....	233
3.1.6	WORK AREA INSPECTION.....	234
<b>3.2.</b>	<b>ENTER THE CABIN.....</b>	<b>235</b>
3.2.1	GETTING IN AND OUT OF THE VEHICLE.....	235
3.2.2	Getting into the vehicle.....	235
3.2.3	Getting out of the vehicle.....	236
<b>3.3.</b>	<b>TURNING THE MACHINE ON AND OFF .....</b>	<b>236</b>
3.3.1	STARTING THE MACHINE .....	236
3.3.2	TURNING OFF THE VEHICLE .....	236
<b>3.4.</b>	<b>USE OF ATTACHMENTS .....</b>	<b>237</b>
3.4.1	SAFETY RECOMMENDATIONS FOR ATTACHMENTS .....	237
3.4.2	COUPLING MANEUVER FOR ATTACHMENTS .....	238
3.4.3	AUTOMATIC RECOGNITION OF THE "E-RECO" ATTACHMENT .....	240
3.4.4	MANUAL SELECTION OF ATTACHMENT HOOK.....	241
3.4.5	FLOW LIMITER OF THE ATTACHMENT CIRCUIT .....	241
<b>3.5.</b>	<b>DRIVING THE MACHINE.....</b>	<b>241</b>
3.5.1	USING STEERING MODES .....	241
3.5.2	USING THE SEMI-AUTOMATIC WHEEL ALIGNMENT .....	242
3.5.3	USING THE PARKING BRAKE.....	243
3.5.4	Using the gear shift selector .....	243
3.5.5	DRIVING MODES .....	244
3.5.6	USING THE FORWARD / NEUTRAL / REVERSE DIRECTION SELECTOR (FNR).....	244
3.5.7	TRAVEL SAFETY SYSTEM RESET BUTTON.....	245
<b>3.6.</b>	<b>STABILITY OF THE MACHINE .....</b>	<b>246</b>
3.6.1	BLOCKING REAR AXLE SWING.....	246
3.6.2	Using the stabilizers.....	246
<b>3.7.</b>	<b>EMERGENCY PROCEDURES.....</b>	<b>249</b>
3.7.1	EMERGENCY PROCEDURE.....	249
3.7.2	Emergency procedure for high-voltage battery fault.....	250
<b>3.8.</b>	<b>USE OF TOWING DEVICES .....</b>	<b>250</b>
3.8.1	PIN AND TOWING HOOK.....	250
3.8.2	COUPLING FORK.....	251
<b>3.9.</b>	<b>TRANSPORT OF THE MACHINE.....</b>	<b>251</b>
3.9.1	TRANSPORTING THE TELESCOPIC HANDLER ON A TRAILER .....	251
3.9.2	PUTTING THE TELEHANDLER IN A SLING AND LIFTING IT .....	253
3.9.3	TOWING OR HOOKING THE TELEHANDLER.....	255
<b>4</b>	<b>MAINTENANCE .....</b>	<b>257</b>
<b>4.1.</b>	<b>MAINTENANCE INTERVALS.....</b>	<b>257</b>
4.1.1	DAILY AND WEEKLY MAINTENANCE.....	257
4.1.2	1st MANDATORY SERVICE WITHIN THE FIRST 500 HOURS OR WITHIN 1 YEAR.....	257
4.1.3	PERIODIC MAINTENANCE .....	257

4.1.4	MAINTENANCE AND OCCASIONAL OPERATIONS .....	257
<b>4.2.</b>	<b>SCHEDULED MAINTENANCE .....</b>	<b>257</b>
4.2.1	1st MANDATORY SERVICE WITHIN THE FIRST 500 HOURS OR WITHIN 6 MONTHS .....	257
4.2.2	DAILY AND WEEKLY MAINTENANCE .....	258
4.2.3	PERIODIC MAINTENANCE .....	259
4.2.4	OCCASIONAL MAINTENANCE .....	261
<b>4.3.</b>	<b>EVERY 10 HOURS OF OPERATION OR DAILY .....</b>	<b>261</b>
4.3.1	CHECKING THE OIL LEVEL IN THE ENGINE .....	261
4.3.2	CHECKING THE COOLANT LEVEL .....	262
4.3.3	CHECKING THE TELESCOPIC BOOM SLIDING SHOES .....	263
4.3.4	CHECKING THE "MSS" SAFETY SYSTEM .....	264
4.3.5	CHECKING THE FUEL LEVEL .....	264
4.3.6	CHECKING DEF LIQUID LEVEL .....	265
4.3.7	FUEL PRE-FILTER CHECK .....	266
4.3.8	CABIN GLASS INTEGRITY CHECK .....	267
4.3.9	CABIN UPPER ANTI-BREAKAGE GLASS INTEGRITY CHECK (OPTIONAL) .....	268
<b>4.4.</b>	<b>EVERY 50 HOURS OF OPERATION OR WEEKLY .....</b>	<b>270</b>
4.4.1	HYDRAULIC OIL LEVEL CHECK .....	270
4.4.2	TIRE PRESSURE AND WHEEL NUT TIGHTENING CHECK .....	271
4.4.3	CLEANING THE RADIATOR GRILLE, HYDRAULIC OIL, INTERCOOLER AND COOLANT .....	271
4.4.4	WINDSCREEN WASHER FLUID LEVEL CHECK .....	272
4.4.5	CHECKING AND CLEANING THE CONDENSER GRILLE (OPTIONAL AIR CONDITIONER) .....	273
4.4.6	GENERAL LUBRICATION .....	274
4.4.7	CLEANING AND LUBRICATION OF THE TELESCOPIC BOOM WEAR SHOES .....	278
4.4.8	CLEANING AND LUBRICATION OF THE TURRET ROTATION FIFTH WHEEL .....	278
<b>4.5.</b>	<b>EVERY 250 HOURS OF OPERATION OR EVERY 6 MONTHS .....</b>	<b>279</b>
4.5.1	FRONT AND REAR AXLE DIFFERENTIAL OIL LEVEL CHECK .....	279
4.5.2	FRONT AND REAR WHEEL REDUCER OIL LEVEL CHECK .....	279
4.5.3	GEARBOX OIL LEVEL CHECK .....	280
4.5.4	BATTERY CHECK .....	280
4.5.5	ROTATION REDUCER FIXING SCREW TIGHTENING CHECK .....	281
4.5.6	EXTERNAL BOOM CHAINS CHECK .....	282
4.5.7	CHECKING STABILIZERS LOWERING AND RAISING SYSTEM .....	285
<b>4.6.</b>	<b>EVERY 500 HOURS OF OPERATION OR EVERY 1 YEARS .....</b>	<b>286</b>
4.6.1	HYDRAULIC OIL CONTAMINATION CHECK .....	286
4.6.2	REPLACING THE HYDROSTATIC PUMP OIL FILTER (TRANSMISSION) .....	287
4.6.3	REPLACING THE HYDRAULIC OIL FILTER CARTRIDGE (DRAIN) .....	287
4.6.4	REPLACING THE HYDRAULIC OIL BREATHER .....	288
4.6.5	CABIN VENTILATION FILTERS CHECK .....	288
4.6.6	FIFTH WHEEL AND TURRET FIXING BOLTS CHECK .....	289
4.6.7	CHECKING THE V-BELT TENSION .....	290
4.6.8	FORKS WEAR CHECK .....	291
<b>4.7.</b>	<b>EVERY 1000 HOURS OF OPERATION OR EVERY 2 YEARS .....</b>	<b>291</b>
4.7.1	FRONT AND REAR AXLE DIFFERENTIAL OIL CHANGE .....	291
4.7.2	CHANGE FRONT AND REAR AXLE FINAL REDUCER OIL .....	292

4.7.3	GEARBOX OIL CHANGE.....	292
4.7.4	DRY AIR FILTER CARTRIDGE REPLACEMENT.....	293
4.7.5	CLEANING THE FUEL TANK.....	294
4.7.6	FUEL PRE-FILTER REPLACEMENT.....	295
4.7.7	FUEL FILTER REPLACEMENT.....	296
4.7.8	ENGINE OIL AND FILTER CHANGE.....	296
4.7.9	COOLANT REPLACEMENT.....	298
4.7.10	CABIN VENTILATION FILTERS REPLACEMENT.....	298
4.7.11	WEAR OF THE EXTERNAL TELESCOPIC BOOM CHAINS CHECK.....	299
4.7.12	CHECK FOR WEAR AND INCREASE IN CLEARANCE OF THE FIFTH WHEEL BEARINGS.....	301
4.7.13	REPLACE FILTER OF THE "DEF" BOOST PUMP.....	301
4.7.14	REPLACE THE "DEF" TANK BREATHER.....	302
4.7.15	SAFETY BELT CHECK.....	302
4.7.17	REPLACING THE INTERNAL STABILIZER COMPONENTS.....	303
<b>4.8.</b>	<b>EVERY 2000 HOURS OF OPERATION OR EVERY 4 YEARS.....</b>	<b>304</b>
4.8.1	TIRE PRESSURE AND WHEEL NUT TIGHTENING CHECK.....	304
4.8.2	HYDRAULIC OIL REPLACEMENT AND HYDRAULICS INTAKE FILTER CARTRIDGE CLEANING.....	304
4.8.4	REPLACEMENT OF THE THREE-PHASE MOTOR SERVICE BELT.....	306
<b>4.9.</b>	<b>EVERY 3000 HOURS OF OPERATION OR EVERY 6 YEARS.....</b>	<b>307</b>
4.9.1	AIR FILTER SAFETY CARTRIDGE REPLACEMENT.....	307
<b>4.10.</b>	<b>OCCASIONAL MAINTENANCE.....</b>	<b>308</b>
4.10.1	INSERTING THE SAFETY WEDGE OF THE TELESCOPIC BOOM.....	308
4.10.2	WHEEL REPLACEMENT.....	309
4.10.3	HEADLIGHTS ADJUSTMENT.....	311
4.10.4	REPLACING THE FUSES AND RELAYS.....	311
4.10.5	CHECK AND CLEANING OF THE TRANSMITTER RINGS OF THE ROTATING ELECTRIC COLLECTOR (AFTER 3 MONTHS OF INACTIVITY).....	320
4.10.6	REMOTE CONTROL CHECK.....	321
4.10.7	CHECKING AND CLEANING THE DEF TANK FILLER FILTER.....	323
4.10.8	STATIONARY REGENERATION OF DPF FILTER "VEHICLE STOPPED".....	324
<b>4.11.</b>	<b>PARKING AND STORAGE.....</b>	<b>324</b>
4.11.1	PROLONGED INACTIVITY OF THE VEHICLE.....	324
<b>5</b>	<b>REFERENCES, OPTIONS AND ACCESSORIES.....</b>	<b>327</b>
<b>5.1.</b>	<b>REFERENCES.....</b>	<b>327</b>
5.1.1	LUBRICANTS AND FUEL.....	327
5.1.2	FILTER ELEMENTS AND BELTS.....	329
<b>5.2.</b>	<b>ATTACHMENTS.....</b>	<b>330</b>
5.2.1	Interchangeable equipment and machine compatibility.....	330
5.2.2	Symbols and description.....	337
5.2.3	Forks carriage.....	338
5.2.4	Buckets.....	345

---

## EXPLANATION OF SYMBOLS

---

### **DANGER**

Indicates an imminent hazardous situation which, if not avoided will result in death or serious injury.

---

### **WARNING**

Indicates a potentially hazardous situation which, if not avoided, may result in death or serious injury.

---

### **CAUTION**

Indicates a potentially hazardous situation which, if not avoided, may result in minor injury or damage to property. It is also used to warn users of unsafe practices.

---

### **NOTICE**

Indicates a practice not related to a physical injury which, if not avoided, may damage the machine.

---



*Indicates a message to draw attention to important information regarding environmental protection.*



*Indicates special tools for performing a task.*



*Indicates the value of tightening torque to be applied.*



*Indicates the weight of an item.  
e.g. it helps to anticipate an action linked to a person's health or the choice of lifting equipment.*

# 1. SAFETY

## 1.1. ORIGINAL SPARE PARTS AND EQUIPMENT

### ⚠ WARNING

Our forklifts must imperatively be maintained with original parts.

By authorizing the use of non-original parts, you risk:

- Legally involving your liability in the event of an accident.
- Technically causing malfunctions to the longevity of the vehicle.

### ⚠ WARNING

The use - by the user - of counterfeit parts or non-approved components can put an end to the contractual warranty conditions and lead the manufacturer to withdraw the Certificate of Conformity.

By using the original parts during maintenance operations, you are legally protected:

- The user who supplies elsewhere does so at his own risk.
- The user who modifies, or has the vehicle modified by third parties, must be aware that a new material is put on the market, which involves his liability.
- The user who copies or has copies made of the original parts exposes himself to legal risks.
- The Certificate of Conformity implies the liability of the manufacturer only for the parts chosen or processed under his control.
- Practical maintenance conditions are set by the manufacturer. If the user does not respect them, the liability of the manufacturer is not involved.

The manufacturer provides the user with:

- Savoir faire and its expertise.
- The guarantee of the quality of the works carried out.
- The original spare parts.
- Preventive maintenance assistance.
- Effective diagnosis assistance.
- The improvements due to an exchange of expertise.

- The training of the staff in charge.
- Only the manufacturer knows in detail the design of the vehicle and therefore the best technological capabilities to ensure its maintenance.

### NOTICE

Original spare parts are distributed exclusively by MANITOU and the dealer network.

## 1.2. RECOMMENDATIONS FOR USE FOR THE DRIVER

### ⚠ WARNING

Most of the accidents related to the use, maintenance and repair of the telehandler are due to the non-application and non-observance of the most basic safety rules.

By identifying the risks to which you expose yourself and taking all necessary precautions, you can avoid these accidents.

### ⚠ WARNING

All operations or maneuvers not described in the instruction manual must be avoided, and in any case anyone who uses another method must first ensure that his own safety, that of others and the good condition of the telehandler are guaranteed.

Therefore, not being able to foresee all the dangerous situations, the recommendations and safety standards relating to the telehandler, given by the manufacturer and reported in this manual, are not to be considered exhaustive.

### ⚠ WARNING

Failure to comply with the safety regulations or the recommendations for use, maintenance or repair of the telehandler can cause serious injury, even death.

**⚠ WARNING**

We draw the attention of users to the risks they face, going at an excessive speed compared to the conditions of circulation, in particular:

Risk of losing control on a rough road.

Increased braking distance.

---

**⚠ WARNING**

The user must always be able to control the telehandler and therefore must:

Adapt the speed to any situation to preserve your own safety, that of others and that of your machine

Continuously evaluate the braking distance.

---

**⚠ WARNING**

Experience teaches us that there may be some contraindications to the use of the telehandler.

These foreseeable anomalous uses, the main ones of which are listed below, are formally prohibited.

---

1. The predictable abnormal behavior, which results from ordinary negligence, but which does not result from the will to misuse the machine.
2. The reflex behavior of a person in case of malfunction, accident, anomaly, etc. while using the telehandler.
3. The behavior resulting from the application of the "law of least effort" when performing a task.
4. For some machines, the predictable behavior of certain categories of people, such as:
  - a. apprentices,
  - b. handicapped,
  - c. staff in training.
5. Drivers tempted to use the telehandler for betting, competitions or from personal experience

**⚠ WARNING**

The plant or site manager must take these criteria into account when assessing a person's ability to drive.

Familiarize yourself with the telehandler on the ground where it will be used.

Transport the load in the low position and with the telescopic boom retracted to the maximum (transport condition).

Position the forks perpendicular to the load to be lifted.

Drive the telehandler at a speed appropriate to the conditions and condition of the ground.

Never go too fast or brake hard with a load.

When picking up a load, make sure the ground is as even as possible.

Do not attempt to perform operations that exceed the capabilities of the telehandler.

Do not lift a load greater than the capacity of the telehandler and do not increase the size of the counterweight.

Go around the obstacles.

Pay attention to electric cables, ditches, recently excavated or brought back land.

Never leave the engine running in the absence of the driver.

Use the parking brake when placing a difficult load or on sloping ground.

Never leave the telehandler parked with a raised load.

Do not allow anyone to approach or pass under a load.

Always think about safety and only carry well-balanced loads.

Never lift a load using only one fork.

Drive carefully and alert.

When the telehandler is not in use, lower the forks to the ground and apply the parking brake.

Never leave the ignition key on the telehandler when the driver is absent.

Do not leave the telehandler loaded on a slope greater than 15% even with the parking brake applied.

When lifting a load, make sure that nothing or no one hinders the movement and avoid making false maneuvers.

Observe the data indicated on the load diagrams.

Never carry another person on the telehandler.

---

**⚠ WARNING**

Whenever a tool is changed, to avoid damaging the hydraulic fittings it is necessary to:

stop the three-phase motor and wait about 1 minute to release the pressure from the circuit.

Wait about 1 minute to release the pressure from the circuit.

---

## NOTICE

### USABILITY

MANITOU has ensured that this vehicle can be used under normal conditions of use as specified in the instruction manual, with a static test coefficient of 1.33 and a dynamic test coefficient of 1, provided for in the harmonized standards EN 1459 for forklift trucks with variable capacity and EN 1726-1 for masted forklift trucks.

## 1.3. GENERAL INSTRUCTIONS

### 1.3.1 INSTRUCTION MANUAL

1. Read carefully and understand the instruction manual.
2. The instruction manual must always be in its place in the telehandler and be in the language spoken by the operator
3. Observe the safety rules and recommendations described for the telehandler.
4. It is imperative to replace all plates or stickers that have become illegible or damaged.

### 1.3.2 DRIVING AUTHORIZATION

**i** Observe the legislation in force in the country of use

Only qualified and specially trained personnel can use the vehicle. Its use is compulsorily subject to the driving authorization issued by the manager of the plant where the machine is used.

- The user is advised to always have driving authorization with him during service.
- The user is advised to always have driving authorization with him during service.
- The use must also comply with the rules of the profession.

### 1.3.3 ROUTINE MAINTENANCE

The user who finds that his vehicle is not working well or does not comply with safety regulations must immediately inform the person in charge.

## ⚠ DANGER

The driver is prohibited from making any repairs or adjustments unless he has been trained for such a task.

You will need to keep your vehicle in perfect condition if you have been instructed to do so.

Carry out daily maintenance.

Check that the tires are suitable for the type of terrain.

## ⚠ DANGER

Do not use worn or deteriorated tires.

## ⚠ DANGER

Fitting tires inflated with polyurethane foam is prohibited and is not guaranteed by the manufacturer, unless authorized.

## ⚠ DANGER

Do not modify the structure or the adjustment of the various components of the vehicle (hydraulic pressure, setting of the limiters, engine speed, installation of additional attachments, etc.).

The same applies to the deactivation or modification of the safety systems. In these cases, the manufacturer will be released from any liability.

To keep the vehicle in a "state of conformity", it is mandatory to carry out periodic checks. The frequency of checks is defined by the legislation in force in the country of use of the vehicle. Maintenance operations or repairs must be carried out by qualified personnel and respecting the safety conditions to ensure your safety and that of others.

### 1.3.4 ENVIRONMENTAL CONDITIONS OF USE

- Our machines are designed for use in a temperature range of between -15°C and +43°C.
- In addition to the standard equipment fitted on the machine, a large number of optionals are also available: road lighting, stop lights, beacon, reversing lights, reversing sound alarm, front worklight, rear worklight, worklight at the top of the boom, etc...
- The operator should take into account the usage conditions to define the signage and lighting of their machine. Contact your dealer.
- Take into account the climatic and atmospheric conditions of the place of use.
  - Frost protection.
  - Adapting the lubricants (contact your dealer).
  - Engine filtration.

## ⚠ CAUTION

The filling of lubricants carried out in the factory is suitable for uses in average climatic conditions, i. e.: between -15 °C and +35 °C.

For uses in harsher conditions, before placing the machine on the road, empty and refill using suitable lubricants according to the environmental temperatures. The same applies to the coolant (-21° C).

- Take into account the risk of fire associated with use in a dusty and flammable atmosphere (e. g. straw, hay, silage, organic waste, etc.).
- MANITOU advises you equip the machine with an individual extinguishing device to neutralize any fire. There are various solutions: please contact your dealer.

## ⚠ CAUTION

This machine is designed for use in outdoor settings in normal atmospheric conditions and in indoor settings that are perfectly aired and ventilated. For use in extremely dusty settings (flour, sawdust), consult your dealer for existing solutions.

Machine use is forbidden in spaces at risk of fire or potentially explosive settings (such as refineries, fuel or gas depots, flammable product storage facilities, etc.). For use in such settings, specific equipment exists (contact your dealer for information).

Our machines conform to directive 2014/30/EU (2015/208/EU for our machines approved as "TRACTOR") relating to electromagnetic compatibility (EMC) and the corresponding harmonized standard EN 12895. Correct operation is no longer guaranteed if they are used in areas where electromagnetic fields are higher than the threshold set by this standard (20 V/m).

- Directive 2002/44/EC requires the plant managers not to expose their employees to excessive levels of vibrations. There is no recognized measurement code that allows machines of various manufacturers to be compared. Consequently, the real levels received can only be received in real conditions, on the user.
- Here are some tips to minimize these levels of vibrations:
  - Choose the machine and the related attachment which best suit the intended use.
  - Adapt the seat adjustment to the operator's weight (depending on the machine model) and keep the seat and cabin suspension in good working order. Inflate the tyres according to the instructions.

- The seat is an essential piece of equipment to reduce the vibrations transmitted to the operator. In the event of seat replacement, contact MANITOU.
- Make sure the operators adapt their operating speed to the condition of the terrain.
- Wherever possible, arrange the terrain to ensure it is as flat as possible, removing any obstacles and potentially dangerous potholes.

### 1.3.5 VEHICLE CAB PROTECTION

- All lift trucks comply with the requirements of ISO 3471 (wheel loader code) regarding cab rollover protection (ROPS) and ISO 3449 (Level II) regarding the protection of the cab against falling objects (FOPS).
- "EC TRACTOR" type-approved lift trucks comply, in addition, with Directive 79/622/EC (OECD Code 4) regarding cab rollover protection (ROPS).

## ⚠ CAUTION

### DAMAGE CAUSED TO THE CABIN STRUCTURE

Structural damage or overturning, a modification, changes or a poorly executed repair can reduce the protective efficiency of the cab, cancelling its compliance.

Do not perform welding or drilling on the cab structure.

Consult your dealer to determine the limits of this structure without cancelling its compliance.

## 1.4. DRIVING INSTRUCTIONS

### 1.4.1 DRIVER SEAT PROVISIONS

1. Wear clothing suitable for driving the vehicle, avoiding those that are too loose. Never ride with wet or greasy hands or shoes.
2. For better comfort, adjust the driver's seat and adopt a good driving position.
3. The driver must always maintain the normal driving position.
4. Always fasten and adjust the seat belt.
5. The control components must never be used for purposes other than those for which they are designed (e. g. : Getting on or off the vehicle, hanging clothes, etc.).

## ⚠ DANGER

Never allow passengers to get on the vehicle or in the driver's seat.

**⚠ DANGER**

It is forbidden to protrude arms and legs and, in general, any part of the body, outside the driving position of the vehicle.

**1.4.2 BEFORE STARTING THE VEHICLE**

- Perform routine daily maintenance.
- Make sure the lights, indicators and wipers are working properly.
- Make sure the rear-view mirrors are in good condition, clean and properly adjusted.
- Make sure the horn is working.
  1. Check the condition and pressure of the tires.
  2. Before starting, check the fluid levels:
    - a. Thermal engine oil.
    - b. Hydraulic tank oil.
    - c. Transmission oil.
    - d. Coolant.
  3. Check for oil, fuel or liquid leaks on the vehicle.
  4. Make sure that the engine cover is closed and locked correctly.

**⚠ DANGER**

No matter how much driving experience he has, the user should familiarize himself with the location and use of all the control and command instruments before putting the vehicle into service.

**1.4.3 STARTING THE VEHICLE****⚠ DANGER**

The vehicle can only be started or maneuvered when the driver is in the driver's seat, with the seat belt fastened and adjusted.

**⚠ CAUTION**

Do not tow or push the vehicle to start it. This maneuver could cause serious damage to the transmission. Put the gear in neutral position if you need to tow the vehicle.

1. Verify that the reverse gear lever is in idleoff.
2. Turn the ignition key to position I to allow electrical contact.
3. Check the fuel level on the gage.
4. Turn the ignition key to position II to allow preheating and wait 15 seconds. (If environmental conditions so require)

**⚠ DANGER**

Do not activate the starter for more than 15 seconds, and allow it to preheat for 10 seconds between all attempts.

5. Turn the ignition key fully.
6. Release the ignition key and let the engine run at low speed.
7. Look at all control instruments immediately after starting, with the engine warm, and at regular intervals during use, in order to quickly identify and resolve any faults. If any of the instruments indicates a fault, stop the engine and carry out the necessary operations right away.

**⚠ DANGER**

Before operating in very cold climatic environments, wait for the three-phase motor and hydraulic systems to warm up correctly.

**1.4.4 TELEHANDLER GUIDE****⚠ DANGER**

The use of the seat belt is mandatory and must be adjusted to the height of the operator. While driving the telehandler, the door must be closed.

- Always fasten and adjust the seat belt.
- Close the door.
- Practice driving the forklift on the ground where it will operate.
- Check the efficiency of the service brakes and the horn.
- Drive appropriately by choosing the appropriate speed for the conditions and the type of terrain.
- Slow down before making a turn.
- Be in control of the forklift and its speed under all circumstances.
- On wet, slippery or uneven ground, drive slowly.

- Brake progressively, avoid sudden braking.
- Act on the reverser of the telehandler only when the machine is stationary, avoiding sudden maneuvers.
- Always remember that the hydraulic steering is very sensitive to the movements of the steering wheel, therefore it is necessary to steer progressively and not jerky.
- Never leave the engine running without the driver.
- Always look in the direction of travel and maintain good visibility of the route. Use the side mirrors frequently, and check their condition, cleanliness and adjustment.
- Do not use the forklift in dark or poorly lit environments.
- At night, check that the telehandler is equipped with work lights.
- Get around the obstacles.
- Do not enter a loading bridge without having checked:
  - That it is correctly positioned and anchored.
  - That the vehicle to which it is connected (wagon, truck, etc.) cannot be moved.
  - That this bridge can bear the total weight of the telehandler and its load.
  - That the width of the bridge is adequate for that of the forklift.
  - That the width of the bridge is adequate for that of the forklift.
- Never enter a gangway, a platform or a freight elevator without being sure that they are designed for the weight and dimensions of the telehandler and its load, and without having checked that they are in good condition.

### ⚠ CAUTION

The travel speed of the loaded telehandler must never exceed 3 km/h (1.9 mph).

### ⚠ DANGER

Move the telehandler into transport position, i. e. boom retracted and 300 mm (11.8 in) from the ground.

1. Check the transmission oil level.
2. Place the forks or attachment in the transport position, i. e. boom retracted and 300 mm (11.8 in) above the ground.

3. Place the reverse lever in the desired position.
4. Release the parking brake and accelerate gently to allow the telehandler to move.

## 1.4.5 STOPPING THE VEHICLE

- Before stopping the vehicle after intense work, let the three-phase motor idle for a few moments to allow the coolant and oil to lower the engine and transmission temperatures.
- Never leave the ignition key in the vehicle when the driver is not there.
- When the vehicle is stationary, place the forks or attachment on the ground, place the shift lever in neutral, apply the parking brake and place the marine gear lever in neutral.
- If the driver has to leave the driver's seat, even temporarily, apply the parking brake and put the gearbox lever in neutral.
- Make sure the vehicle is parked in such a way as not to impede traffic and at least one meter away from the railroad tracks.
- In case of prolonged parking, protect the vehicle from bad weather, particularly in the event of frost (check the antifreeze level), close the rear window, lock the cabin door and the engine cover.

### ⚠ DANGER

Before leaving the driver's seat, make sure you have carried out all the vehicle stopping operations correctly.

1. Park the vehicle on level ground or with a gradient of less than 15%.
2. Place the reverse gear lever in idlesoff.
3. Apply the parking brake.
4. Fully retract the boom.
5. Place the forks or the attachment on the ground.
6. Switch off the three-phase motor.
7. Remove the ignition key.
8. Check that the door is locked and that the rear window and engine cover are also closed.

## 1.4.6 DRIVING THE VEHICLE ON THE ROAD

- Drivers of vehicle traveling on the road must comply with the general regulations relating to road traffic.
- The vehicle must comply with the traffic regulations of your country.

**⚠ DANGER**

The transport of loads by road is prohibited and the attachments mounted on the vehicle must be equipped with the required equipment or be disassembled.

**⚠ DANGER**

The vehicle can travel on public roads only empty, i. e. unladen.

Transportation of people is prohibited.

1. Verify that the flashing lights are installed and functioning.
2. Always fasten and adjust the seat belt.
3. Close the door.
4. Dipped beam headlights also on during the hours and in the streets where the use of visual signaling and lighting devices is not required.
5. Check the correct operation and cleanliness of the headlights, indicator lights and windscreen wipers.
6. Check the position of the rear view mirrors.
7. Check wheel alignment and push the steering selector to the drive position with front steering wheels only.
8. Make sure the battery charge is sufficient.
9. Fit all the attachments required for road traffic (according to model and country).
10. Put the boom in the transport position, i.e. boom retracted and 300 mm (11.8 in) above the ground.
11. Level the machine with the chassis parallel to the ground using the tilt corrector.
12. Raise and retract the stabilizers as far as possible.

## 1.5. HANDLING INSTRUCTIONS

### 1.5.1 HANDLING INSTRUCTIONS

- Check the conformity of the attachments with the calibration of the safety system of the machine.
- Check the proper functioning of the telehandler attachments.
- Do not perform operations that exceed the capabilities of the telehandler or attachment.

- It is forbidden to increase the counterweight value whatever the artifice used.
- It is strictly forbidden to transport or lift people with the telehandler, unless it is equipped for this purpose and provided with the certificate of conformity relating to lifting people.
- Avoid making long journeys in reverse.
- Carry out slow and progressive maneuvers to raise and lower the telescopic boom (even without load).

**NOTICE**

The machine with rotated turret, telescopic boom extended and raised over 3 m does not translate.

- Check that the attachment is correctly installed and locked on its holder.
- Verify that you have set the safety system in the cabin in accordance with the attachment fitted.
- Respect the limits of the attachment load chart.
- Check that the pallets, crates, etc. are in good condition and suitable for the load to be lifted.
- Position the forks perpendicular to the load to be lifted, taking into account the position of the center of gravity of the load.
- Never lift a load with only one fork.
- Never lift a sling load with a single fork or with a forks carriage.
- If not used, place the attachment horizontally on the ground (prop up unstable attachments correctly).
- Check that the hydraulic quick couplings of the attachment circuit are clean and protected.

**⚠ WARNING**

Before each change of hydraulic attachment, in order to avoid deterioration of the hydraulic quick couplings it is necessary to:

Before each change of hydraulic attachment, in order to avoid deterioration of the hydraulic quick couplings it is necessary to:

Wait about 1 minute to release the pressure in the hydraulic circuit.

- Verify that there is adequate lighting.
- When lifting a load, be careful that nothing or nobody hinders the correct execution of the operation and avoid any false maneuvers.
- In the case of work carried out near overhead power lines, make sure that the safety distance

between the working area of the telehandler and the power line is sufficient.

## ⚠ DANGER

You risk being electrocuted or seriously injured if you work or park the telehandler too close to electrical cables. We strongly advise you to make sure that the safety rules applied on the site comply with local regulations in force regarding all types of work carried out in the vicinity of power lines.

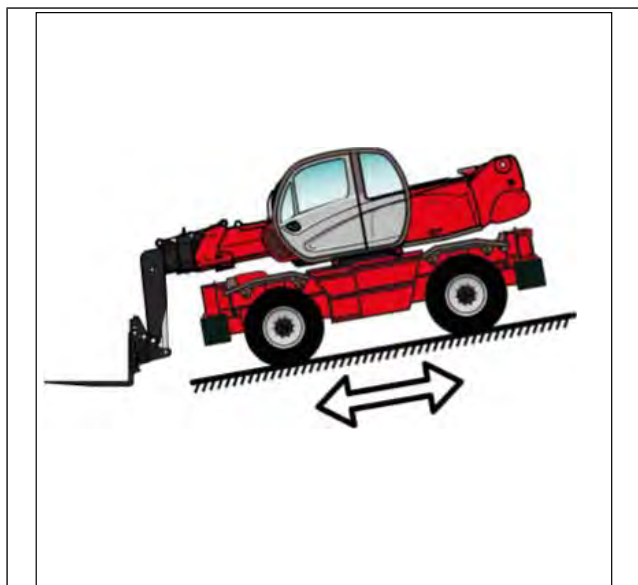
- Forbid anyone to approach the maneuvering area of the telehandler or to pass under a load.

## ⚠ DANGER

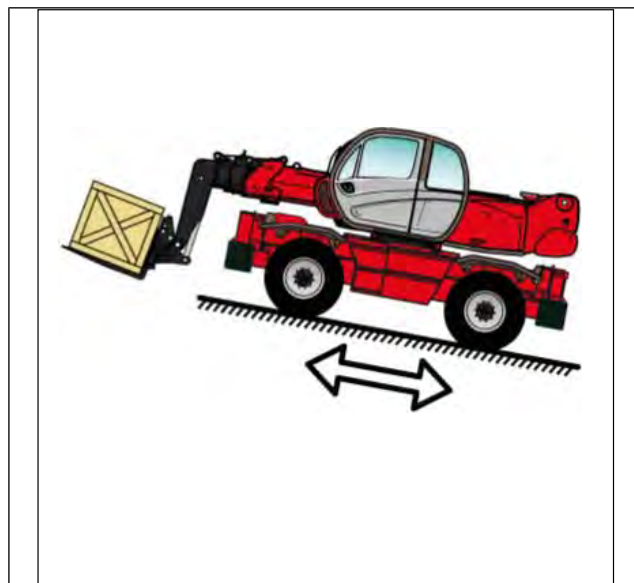
For use on sloping ground, before raising the boom, check that the ground is level.

Telehandlers equipped with level corrector and/or stabilizers can operate on transverse slopes, provided that this inclination is corrected.

- Check that the scaffolding, the loading surface or the stack can support the load.
- Make sure of the stability and compactness of the ground before placing the load.
- Movements on longitudinal slopes:
  - Advance and brake smoothly.
  - Unladen movement: The forks or attachment facing downstream.



- Laden movement: The forks or attachment facing upstream.



## ⚠ DANGER

Always observe the safety rules, always carry loads balanced and correctly arranged to avoid any risk of overturning.

1. Fully insert the forks under the load and move it to transport position (forks 300 mm from the ground, boom fully retracted and forks tilted back).
2. For obvious reasons of telehandler stability and good visibility, move the telehandler only when the boom is in the transport position.
3. Only operate the telehandler with the boom raised in exceptional cases; then operate with extreme caution, at very low speed and braking very gently.
4. Make sure you always have sufficient visibility, possibly be guided by another person.
5. Keep the load stable when the telehandler is in motion.
6. Never advance too fast or brake sharply with a load.
7. During handling operations, drive at reduced speed.
8. Monitor the load, especially when cornering, especially if it is bulky.
9. Sling unstable loads.
10. Handle loads carefully, at low speed and without jerks, especially when you take them to great heights and with considerable overhang.
11. In case of strong wind or storm, do not carry out movements that are potentially dangerous for

the stability of the telehandler and the load, do not change direction abruptly and at high speed.

12. Use the parking brake to place or lift a difficult load or on sloping ground.
13. Never leave the forklift stationary with a lifted load.
14. Do not leave the telehandler, laden or empty, with the parking brake applied on a slope greater than 15%.
15. Always have good visibility of the route, both in direct vision and in indirect vision, i. e. with panoramic rear view mirrors, to check for the possible presence of people, animals, holes, obstacles, slope variations, etc.
16. Visibility may be reduced on the right side when the boom is raised; therefore make sure that the route is well visible before raising the boom and before maneuvering.
17. If forward visibility is insufficient due to the bulk of the load, drive in reverse. This maneuver has an exceptional character and can only be carried out for short distances.
18. Make sure you have good visibility (clean windows, sufficient lighting, adjusted rear view mirror, etc.).
19. The signaling systems and lights of the telehandler must be suitable for the conditions of use. The standard illumination of the machine is not sufficient for use in low-light environments or for use at night.

## ⚠ DANGER

If the telehandler overturns, do not attempt to get out of the cabin during the accident.

Always drive with seat belts fastened. Being seated in the cabin is your best protection.

## 1.6. HANDLING OF A LOAD

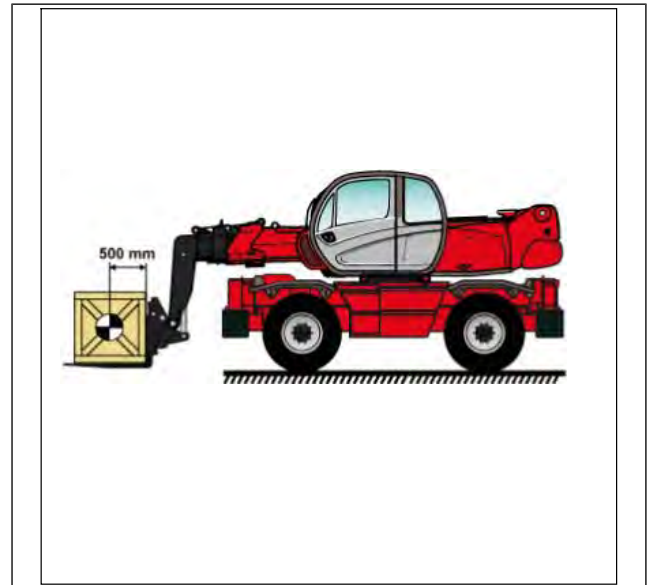
### 1.6.1 LOAD WEIGHT AND CENTER OF GRAVITY

## ⚠ WARNING

It is forbidden to lift and transport a load greater than the rated capacity of the telehandler or attachment.

- Before lifting a load, you need to know its weight and center of gravity.

- The load chart for your telehandler is valid for a load whose center of gravity is 500 mm from the heel of the forks.



- For uneven loads, determine the center of gravity in the transverse direction before each movement.

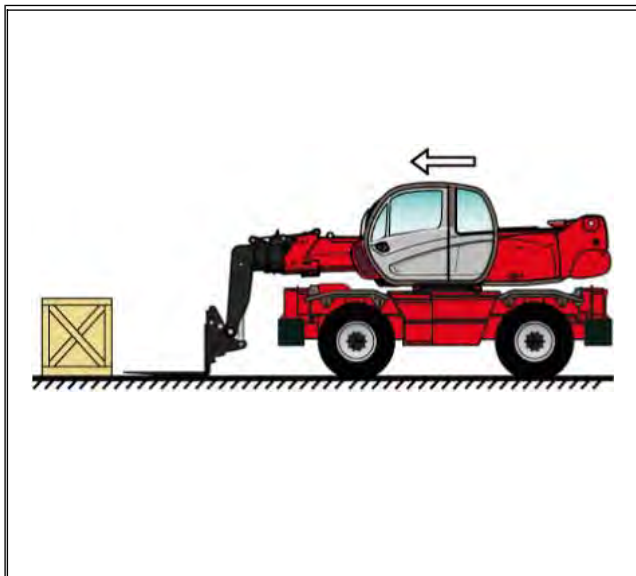


## ⚠ WARNING

For loads with a mobile center of gravity (for example: liquids), it is necessary to take into account the variations in the center of gravity to determine the load to be handled and to pay particular attention and prudence in order to limit these variations to the maximum.

## 1.6.2 PICKING UP A LOAD FROM THE GROUND

1. Move the telehandler perpendicular to the load, with the boom retracted and the forks horizontal.



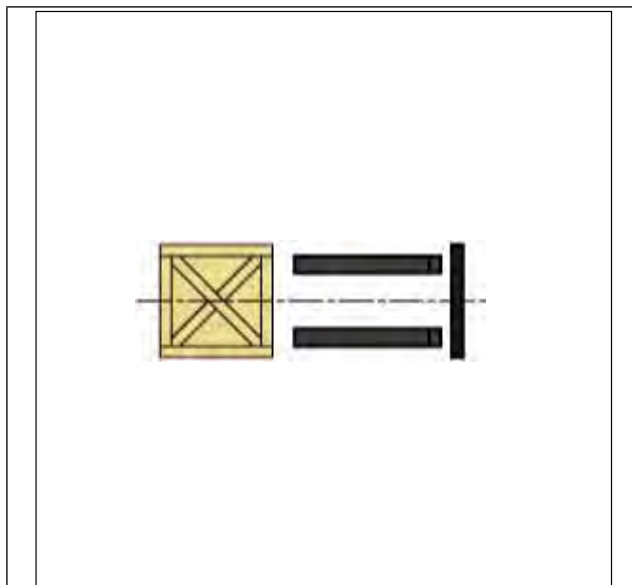
2.

### ⚠ WARNING

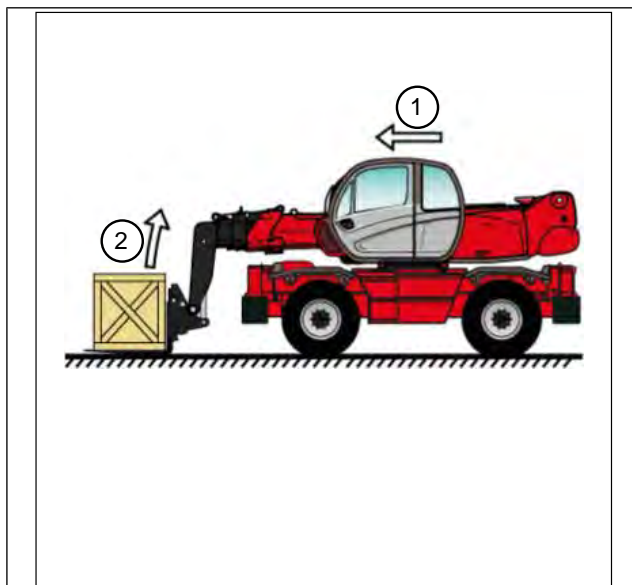
Beware of the risk of pinching or crushing of limbs during manual adjustments of the forks.

Always maintain an equal distance between the forks and the central axis of the forks carriage to ensure perfect stability of the load.

Adjust the offset and centering of the forks with respect to the load.

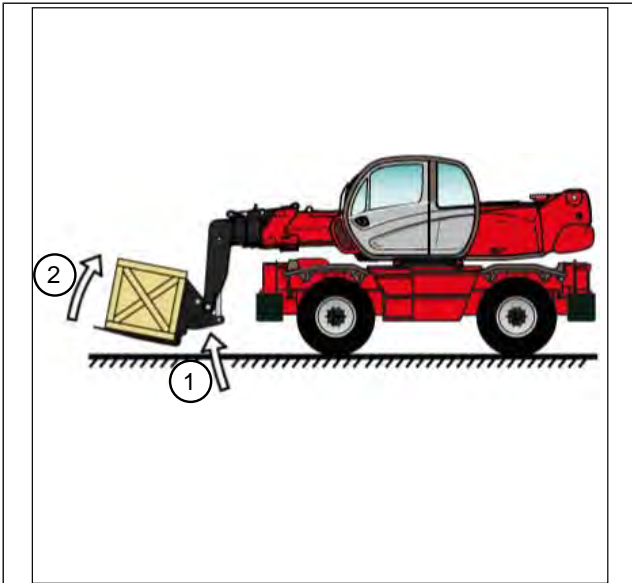


3. - Slowly advance the telescopic handler (1), and move the forks against the load, if you need to raise the boom (2) slightly when picking up the load.



4. Apply the parking brake and place the reverse lever in idleoff.

- Slightly raise the load (1), tilt the forks carriage (2) back into transport position.



### ⚠ WARNING

Tilt the load sufficiently backwards to ensure stability (loss of load during braking), but be careful not to change its balance.

### 1.6.3 PICK UP A LOAD UP ON TIRES

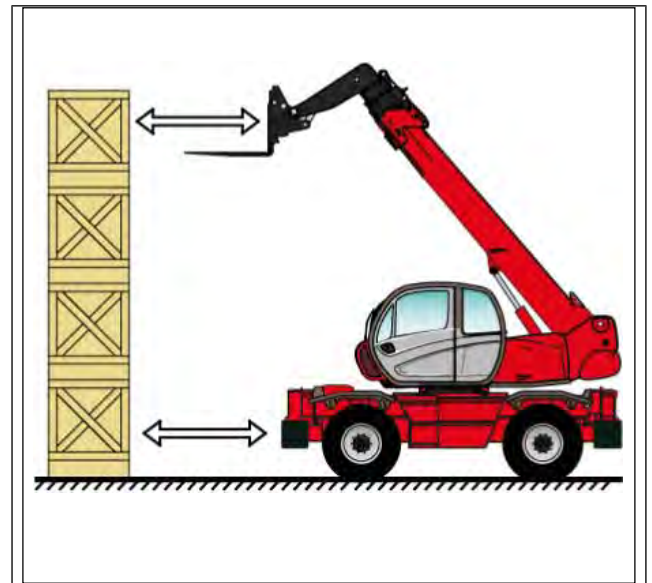
### ⚠ WARNING

It is strictly forbidden to pick up a load if the telehandler is not level

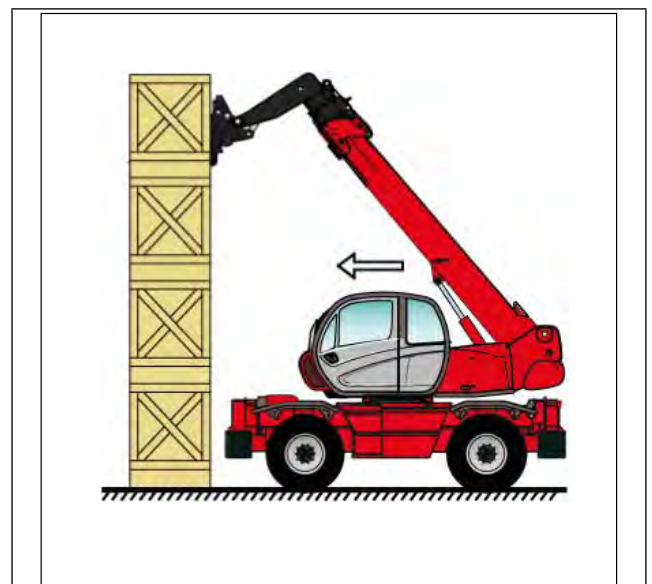
- Check that the forks pass easily under the load.
- Move the telehandler perpendicular to the load with the horizontal forks, maneuvering gently and carefully.

### ⚠ WARNING

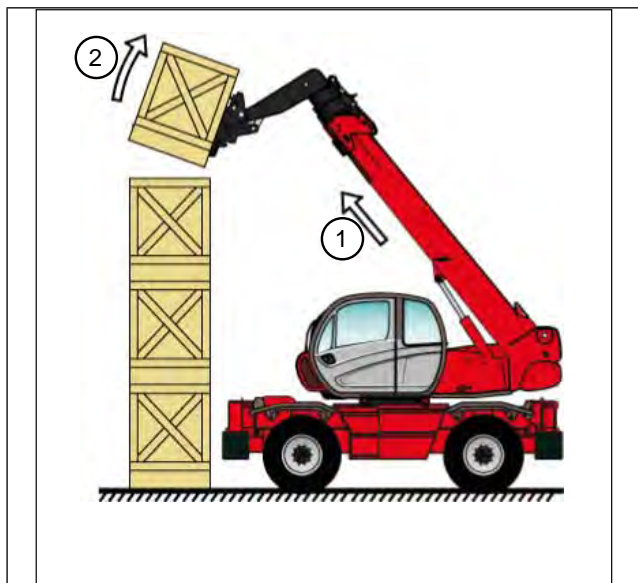
Remembering to always keep the distance necessary to insert the forks under the load, between the stack and the telehandler, using the minimum possible length of the boom.



- Bring the forks against the load. Apply the parking brake and place the reverse lever in idloff.



- Slightly lift the load (1) and tilt the forks carriage (2) back to stabilize the load



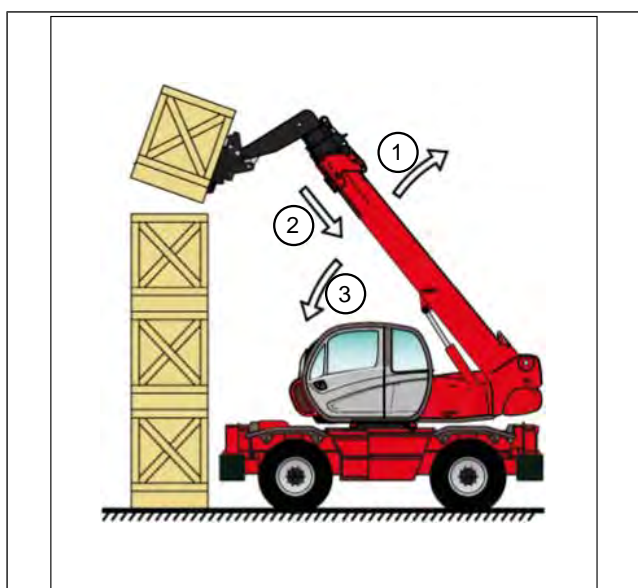
5.

### ⚠ WARNING

Tilt the load sufficiently backwards to ensure stability (loss of load during braking), but be careful not to change its balance.

If possible, lower the load without moving the telehandler.

- a. Raise the boom (1) to remove the load,
- b. retract (2) and lower the boom (3) to bring the load into transport position.



6. If this is not possible, move the telehandler back.
  - a. Maneuvering very gently and with extreme caution, move the telehandler (1) back to remove the load,

- b. retract (2) and lower the boom (3) to bring the load into transport position.

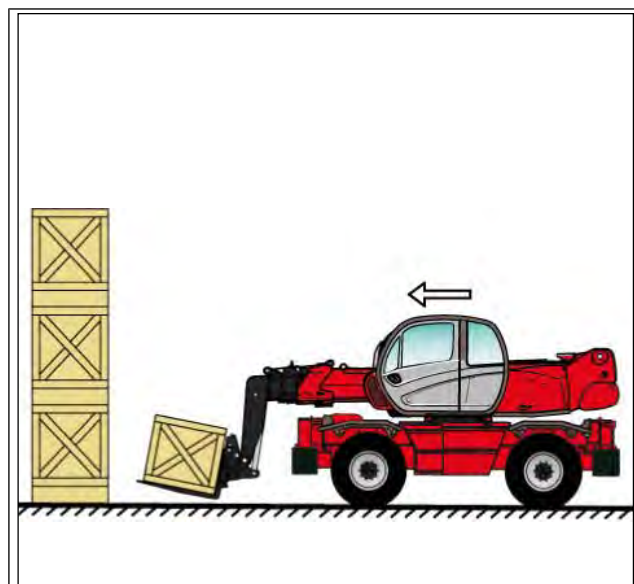
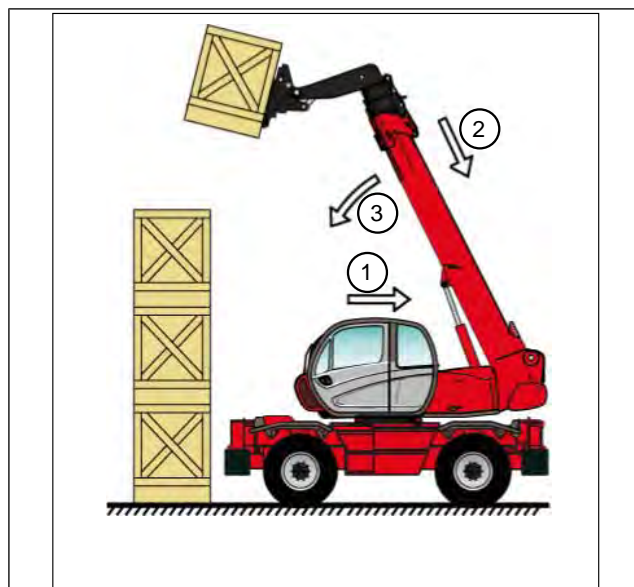
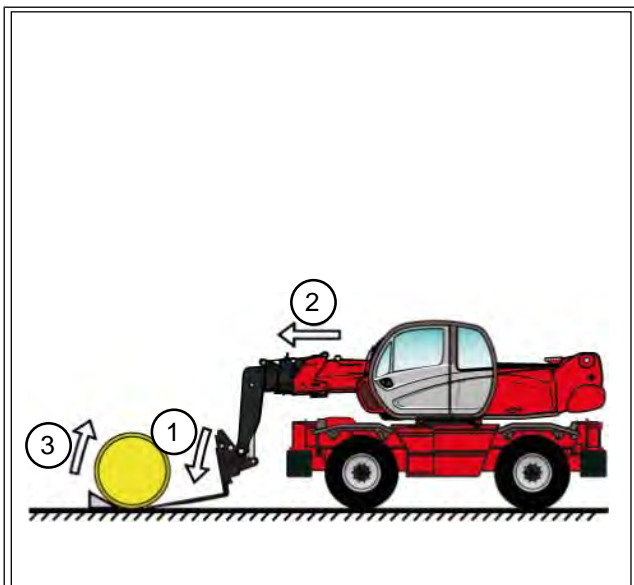


Figure 1: Load in transport position

### 1.6.5 PICKING UP A LOAD WITHOUT A PALLET

1. Tilt the forks (1) forward and extend the boom (2) while at the same time tilting the forks (3)

back to insert the forks under the load. If necessary, stop the load with a wedge.



### 1.6.6 LOAD STATUS INDICATOR DEVICE

1. Always observe the load status indicator during handling.

## 1.7. INSTRUCTIONS FOR USING THE RADIO CONTROL

### 1.7.1 RECOMMENDATIONS FOR USING THE REMOTE CONTROL

#### Compliance

Each remote control complies with Directive 1999/5 / EC (RTTE) and its essential requirements. Each remote control also complies with the harmonized standards reported in the EC declaration of conformity.

#### Radioelectric connection

The two units communicate with each other continuously via a radio link. This is a necessary requirement to ensure the safety of the remote controlled machine. The units encode messages using an address stored in the S-KEY and in the code key present in the connector of the receiving unit. This address is unique, univocal (specific for each remote control) and not reproducible. Each unit can only decode messages from the unit that has the same address. This excludes that a message from another radio device activates any system function.

The units send each other the coded messages:

- those sent by the transmitting unit contain the operating commands that will be implemented by the machine;
- those sent by the receiving unit contain useful information for the automatic management of the working frequency and information regarding the measurements carried out on the machine (Data Feedback function).

#### Frequencies

The radio connection between the remote control units takes place at one of the frequencies permitted by the regulations in force at the time of placing on the market.

#### Safety functions

The remote controls are equipped with some functions that provide a high level of safety in order to preserve the safety of people and things.

#### Stopping function

The stop function brings the machine to a safe state whenever it needs to be stopped due to a potentially dangerous situation. Depending on the case, this function is activated voluntarily by the operator (active stop) or intervenes automatically and autonomously (passive stop).

#### Active stopping

Active stopping is a function activated by the STOP button. The transmitting unit sends a command to the receiving unit to stop the machine immediately. Stopping the machine using the STOP button takes place in a shorter time than that obtained through the passive stop.

#### Passive stopping

Passive stopping is a function that intervenes as a consequence of an anomalous situation that occurs during operation. When the radio connection is incorrect or interrupted, the receiving unit decides autonomously to stop the radio control. Protection from unwanted movements from the UMFS rest position. This safety function protects the "machine + remote control" system from unwanted movements, understood as machine movements not activated voluntarily by the operator, but caused by any electrical and mechanical failures of the radio control. This protection controls the neutral (rest) position of the actuators that control the movements in the machine. Whenever one of these actuators is operated, the transmitting unit sends both the motion command and the command.

#### SAFETY

Depending on the application, the outputs relating to these commands are wired in series or the outputs of the SAFETY command pilot the safety device provided on the machine.

## ▲ WARNING

In addition to all the indications imposed by the manufacturer of the machine, by the installer of the remote control and by the person in charge of safety in the work area, an operator must always respect the following warnings:

The transmitter unit must be used in an easy and comfortable way, preventing it from falling accidentally. The strap supplied with the remote control serves this purpose.

Put yourself in a position that allows direct control of the remote controlled machine and of the movements of the load, as well as in a position that guarantees its safety conditions with respect to other operations and/or activities and/or processes that take place in the workplace .

Never start up or use the transmitter unit in work situations in which you may lose your balance or trip.

Always check the correct mechanical functioning of the STOP button. If it is impossible or difficult to operate this button, do not use the remote control.

Never start the transmitter unit except to start working: improper use could cause dangerous situations.

Never start or operate the transmitter unit in closed places, out of sight or out of the range of action typical of the radio control: even in these cases it is possible to create a radio connection with the risk of making the remote controlled machine execute unwanted commands.

During normal operation, follow all the movements of the machine and of the load by direct visual control while remaining within the operating range of the remote control. Pay attention to visual and acoustic warnings and signals and take all precautions and actions necessary to prevent the movement of the remote controlled machine from creating dangerous situations for people and/or things.

Pay attention to the entire work area and intervene immediately by pressing the STOP button when a dangerous situation arises.

Avoid touching the metal part of the receiving unit as it could reach high and potentially dangerous temperatures.

In case of malfunction, shut down the "machine + remote control" system until the problem is completely eliminated.

After using the remote control, turn off the transmitter unit when suspending or temporarily interrupting work, avoiding leaving the load suspended (even when replacing the discharged battery).

Never leave the transmitter unit unattended with the S-KEY inserted.

Always store the S-KEY in a safe place whenever it is removed from the transmitter unit.

If this key is lost, it is impossible to operate the remote control as the transmitting unit needs the address stored in the key to work with the relative receiving unit.

## ▲ WARNING

### Remote control life cycle

To ensure safe and long-lasting use of the remote control, it is necessary to carefully follow the instructions relating to each phase of the product's life:

- transport: a remote control must be transported and kept in its original packaging until it is installed on the machine.
- installation: the installation and testing of the remote control must be carried out exclusively by qualified personnel, possessing the necessary technical knowledge to carry out these operations and qualified according to the provisions of the country in which the assembly is carried out.

Only a correct installation can ensure a safe use of the remote control.

Usage:

a radio remote control must be used by qualified and adequately trained personnel.

Radio remote control maintenance:

the following instructions provide information to safely carry out routine and extraordinary maintenance operations on the remote control:

- routine maintenance is the operation or set of operations necessary to maintain the normal conditions of use of the remote control through set-up, verification, scheduled replacement of the parts, which are made necessary by normal use of the remote control.
- Extraordinary maintenance is the operation or set of repair operations necessary for breakdowns, breakages or malfunctions of the remote control, which have the purpose of restoring the original conditions of use and operation.

Before calling in the service technicians of the machine manufacturer, it is advisable:

- to have read and understood this manual in all its parts, checking that all the instructions contained therein have been correctly carried out
- to have followed the instructions to search for possible malfunctions and their causes.

Any faults can only be repaired by authorized personnel, contact the MANITOU assistance service.

To make a faster and more effective intervention possible, the data for a correct and complete identification of the remote control must be communicated:

1. serial number (S/N) of the remote control and the TU ID (identification number of the transmitter unit)
2. date of purchase (shown on the certificate of warranty)
3. anomaly found
4. address and telephone number of the place where it is used

All remote control set-up and maintenance interventions must be checked and recorded by the machine maintenance manager.

In case of breakdown, emergency, or damaged parts, the "machine + remote control" system must be put out of service until the problem is completely eliminated.

Before any maintenance operation, remove the transmitter unit battery and the receiver unit power supply.

After each maintenance operation, always check that the commands sent by the transmitting unit only activate the planned maneuvers.

### Scrapping of the remote control.

For scrapping, entrust the remote control to the differentiated scrap recovery service existing in the area.

In particular, be careful when recycling batteries by applying local regulations.

Do not dispose of them with household waste.

### General operating instructions

#### Starting the remote control.

The start-up of the remote control consists in establishing the radio connection between the transmitter and receiver units. To achieve this, it is necessary:

- to power the receiving unit respecting the voltage limits indicated in the technical data. The POWER LED lights up,
- insert a fully charged battery in the transmitter unit,
- insert the S-KEY in the transmitter unit
- press the START button on the transmitter unit until the POWER LED on the receiver unit and the green LED on the transmitter unit start flashing slowly.

#### Activation of commands

With the remote control started, it is possible to operate the joysticks, buttons and selectors relating to the command to be carried out.

To know the correspondence between the actuators and the operations of the machine, the operator must be adequately trained regarding the symbols present on the panel of the transmitting unit.

#### Data Feedback function

The Data Feedback function makes the information and/or signals regarding the machine he is controlling available to the operator.

During normal operation of the remote control, pay attention to the indications displayed and signaled by the display or by the LEDs: they are an aid in assessing the operating situation in which the machine is located.

When operating and controlling the machine, consider that the remote control does not intervene autonomously in the potential danger situations displayed and signaled.

#### Operation with display

If there is a display in the transmitting unit, the signaling icons, the values of the measurements carried out in the machine and their descriptions can be displayed.

#### Operation with LEDs.

If there are LEDs in the transmitter unit, when they turn on, it indicates particular conditions of the machine.

Interruption of the radio connection.

When the radio connection is incorrect or interrupted for a certain time, the passive stopping function intervenes.

The green LED of the transmitter unit changes from slow to fast flashing.

The POWER LED of the receiving unit changes from flashing to steady on.

To start the remote control, press the START button.

Automatic switching off of the transmitter unit.

The automatic switching off of the transmitting unit occurs when:

- the battery is flat, the remote control is not used for a set time,
- the transmitting unit remains powered for eight hours without ever being turned off.
- The green LED of the transmitter unit goes out.
- The POWER LED of the receiving unit changes from flashing to steady on.
- To start the remote control, press the START button.

#### Low battery

The transmitter unit signals if the battery is not sufficiently charged (the red LED flashes accompanied by an acoustic signal). After 3.5 minutes from the start of the signal, the transmitting unit switches off automatically. You need to replace the battery with a charged one.

#### Non-use of the transmitter unit

If the transmitting unit remains on for a time equal to the "auto-off time" without the commands being activated, it switches off automatically.

#### Continuous use

The transmitter unit signals if it has never been switched off after eight hours (the red LED flashes accompanied by an acoustic signal). After 3.5 minutes

from the start of the signal, the transmitting unit switches off automatically.

### Switching off of the transmitter unit

The transmitter unit must be switched off every time work is suspended: remove the S-KEY and always put it in a safe place.

### Switching off the receiver unit

The receiver unit must be switched off every time the remote control is not used to control the machine. To turn off the unit, it is necessary to disconnect the power supply.

## 1.8. TELEHANDLER MAINTENANCE INSTRUCTIONS

### 1.8.1 RECOMMENDATIONS FOR MAINTENANCE

Before carrying out any routine or extraordinary maintenance on the telehandler, follow the instructions below.

#### ⚠ WARNING

The vehicle is equipped with two ladders (front and rear) that allow access to the walkable surface above the vehicle's undercarriage. The latter must only be used during maintenance operations to access the walkable surface.

It is not allowed to use the front or rear ladder to access the vehicle cabin.

1. Read carefully and understand the instruction manual.
2. Switch off the three-phase motor before any intervention on the telehandler.
3. Wear appropriate clothing for the maintenance operations of the telehandler, avoiding jewelry and clothing that is too loose. If necessary, tie and protect the hair.
4. Make sure that the room is sufficiently ventilated before starting the telehandler.
5. Make any necessary repairs, even minor ones, immediately.

#### NOTICE

Pay particular attention to the disposal of consumables and used parts, making sure that it is carried out in maximum safety and in an eco-friendly way.

6. Repair any leaks, even the smallest ones, immediately.
7. Do not try to loosen fittings, hoses or a hydraulic component with the circuit under pressure.

#### ⚠ WARNING

The modification of the adjustment and the disassembly of the counterbalance valves or of the safety valves which, at times, equip the jacks of the telehandler can be dangerous. A counterbalance valve can only be removed with the concerned jack at rest and with the hydraulic circuit without pressure. This operation can only be carried out by authorized personnel.

8. Do not smoke or approach the telehandler with open flames when the fuel tank is open or filling.
9. Pay attention to the risk of burns (fume treatment system, hood, radiator, three-phase motor, etc.).
10. Disconnect the negative pole (-) from the battery before working on the electrical system.
11. Do not place metal pieces on the battery.
12. To carry out an electric welding on the telehandler, place the clamp of the negative cable of the welding machine directly on the piece to be welded in order to prevent very strong current from flowing through the alternator.

### 1.8.2 INSTRUCTIONS FOR TIRE MAINTENANCE

- The operator must ensure tires are adapted to the nature of the ground. There are optional solutions, consult your dealer.
  - SAND tires.
  - FARM tires.
  - Snow chains
- The lift truck's four tires must be the same brand and the same usage category (normal, snow or special), have the same structure (radial or diagonal) and have the same degree of tread wear.
- In the event of tire replacement, use tires authorised by MANITOU that are the same type and dimensions. Using different tires voids the lift truck's type approval and you may be liable.
- If you are replacing just one of the lift truck's tires (e. g. because it is damaged), we recommend choosing a tire with the same degree of wear as the remaining tires so as not to damage the transmission's kinematic chain.

**⚠ CAUTION****TIRES NOT CONFORMING TO USE**

The fitting of foam inflated tires is prohibited and is not guaranteed by the manufacturer, excepting prior authorisation.

Do not use the lift truck if the tires are incorrectly inflated,

damaged or excessively worn, because this could put your own safety or that of others at risk, or cause damage to the lift truck itself.

---

## 1.9. MAIN PARTS OF THE VEHICLE

### 1.9.1 MAIN PARTS OF THE VEHICLE

Depending on the vehicle model

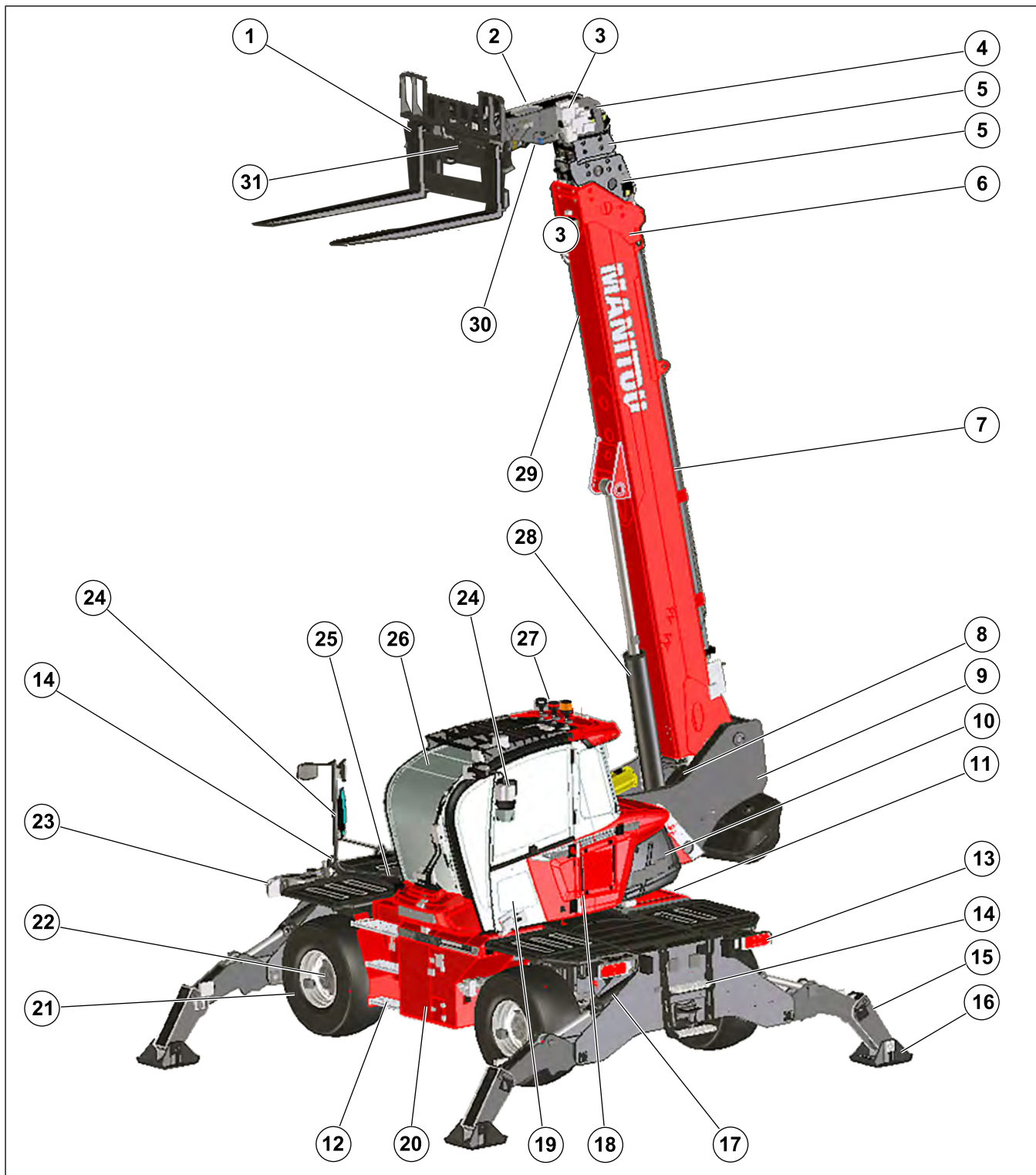


Figure 2: Main parts of the vehicle

Table 1. Main parts of the vehicle

Typical MRT with telescoping boom

Item	Description	Note
1	Fork carriage with Forks	Example of Interchangeable equipment
2	Hydraulic coupling connectors	Depending on the interchangeable equipment

<b>Item</b>	<b>Description</b>	<b>Note</b>
3	Electrical coupling connectors	Depending on the interchangeable equipment
4	Fly boom	
5	Mid boom	Depending on the vehicle model
6	Base boom	
7	Telescoping boom assembly	
8	Compensation cylinder	
9	Turnable turret	
10	Cabin rear compartment	
11	Engine area	
12	Ladder to access in the cabin	Located on the left side of the vehicle (fuel tank area)
13	Taillight (x2)	
14	Ladder to access to the frame walkable surface (x3)	Located on the front, rear and right side
15	Stabilizer boom (x4)	
16	Stabilizer foot (x4)	
17	Stabilizer ascent-descent cylinder (x4)	
18	Swing bearing	
19	Cabin door	
20	Tanks area	
21	Wheel (x4)	
22	Steer and Drive axle (x2)	
23	Headlight (x2)	
24	Mirrors	
25	Frame	
26	Cabin	
27	Beacon lights	
28	Boom lift cylinder	
29	Boom hydraulic hoses	
30	Quick coupler tilt cylinder	
31	Boom quick coupler	

## 1.10. INFORMATION FOR THE ENVIRONMENT

### 1.10.1 RECYCLING OF MATERIALS

#### METALS

- Metals are 100 % recoverable and recyclable.

#### PLASTICS

- Plastic parts are identified with a marking in accordance with current regulations.
- A limited range of materials is used to simplify the recycling process.

- The majority of plastic components are made of "thermoplastic" plastics, that are easily recycled by melting, granulating or grinding.

#### RUBBER

- Tyres and seals can be ground for use in cement manufacture or to obtain reusable granules.

#### GLASS

- Glass items can be removed and collected for processing by glaziers.

## 1.10.2 VEHICLE DISPOSAL

MANITOU complies with the regulations deriving from Directive 2000/53/EC relating to vehicle end-of-life.

This vehicle contains no substances or materials forbidden by Directive 2000/53/EC.



*Consult your dealer before disposing of your vehicle.*

## 1.10.3 ENVIRONMENTAL PROTECTION

By entrusting the maintenance of your vehicle to the MANITOU network, the risk of pollution is limited and the contribution to environmental protection contribution is made.

### WORN OR DAMAGED PARTS

- Do not dump them in the countryside.
- MANITOU and its network have signed-up to a scheme of environmental protection through recycling.

## 1.11. DECALS LOCATION

### 1.11.1 DECALS - LOCATION

#### **⚠ DANGER**

Clean all the safety decals to keep them legible. It is essential to replace decals which are illegible or damaged. Check the presence of decals after replacing any spare parts.

### USED OIL

- The MANITOU network organises the collection and processing of used oil products.
- By handing over your waste oil to MANITOU, the risk of pollution is limited.

### USED BATTERIES

- Do not throw away batteries, as they contain metals that are harmful for the environment.
- Return them to the MANITOU network or any other approved collection point.

#### **NOTICE**

**MANITOU aims to manufacture vehicles that provide the best performance and limit polluting emissions.**

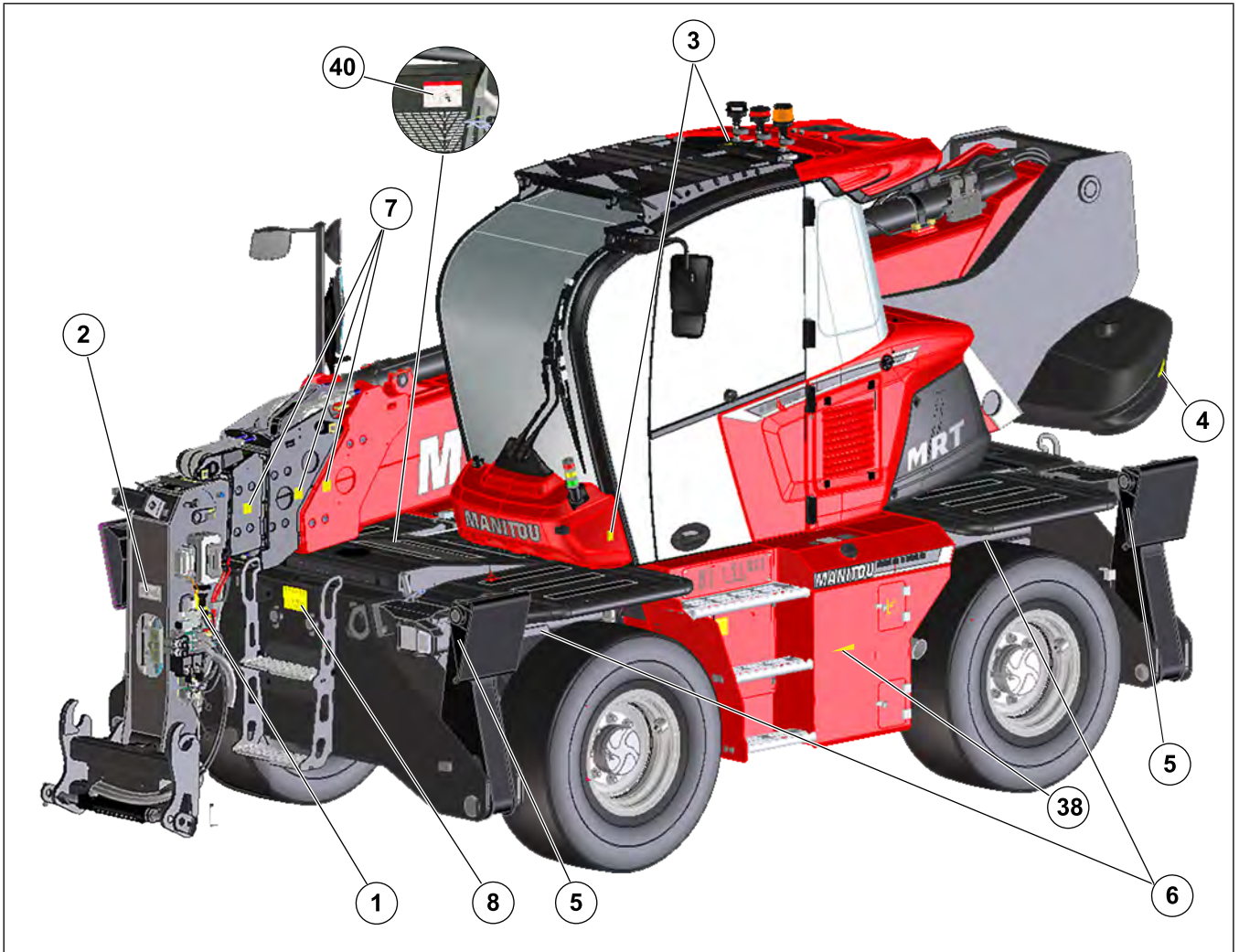


Figure 3: Decals - Location - Left side



Figure 4: Decals Location - Right side

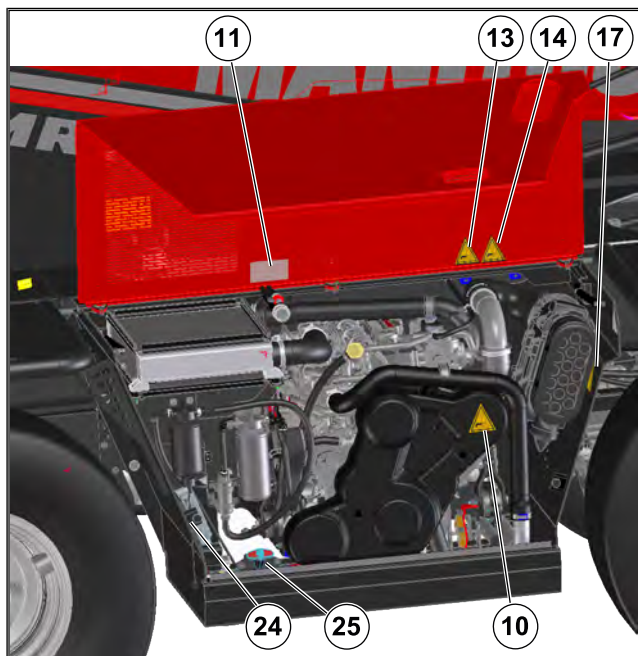


Figure 5: Decals - Location - Engine area (MRT 1645 – MRT 1845)

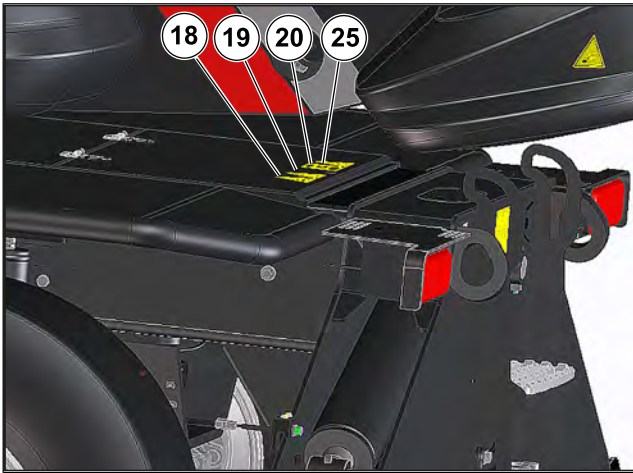


Figure 6: Decals - Location - Battery area (MRT 1645 – MRT 1845)

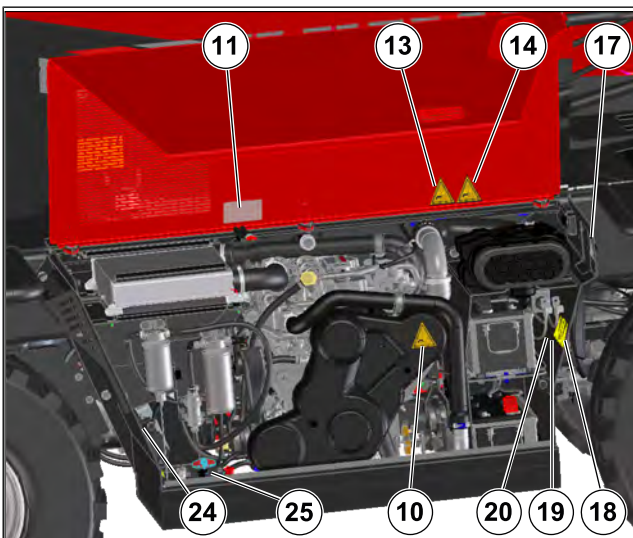


Figure 7: Decals - Location - Engine and battery area (MRT 2145 – MRT 2545)

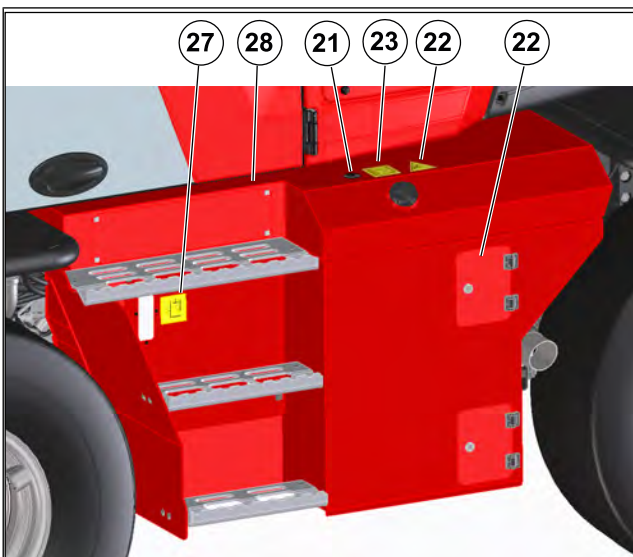


Figure 8: Decals - Location - Tanks area

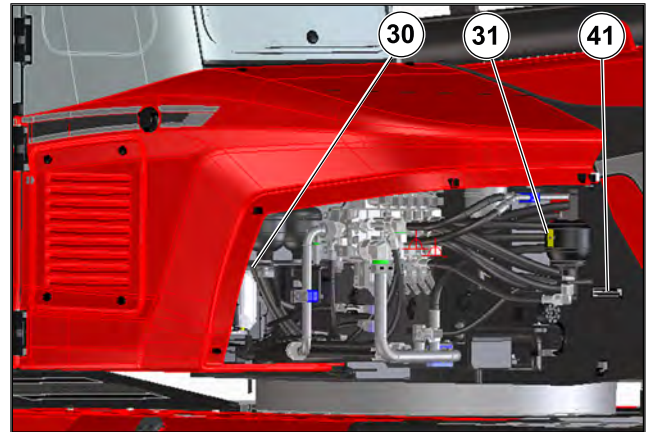


Figure 9: Decals - Location - Bonnet behind cabin

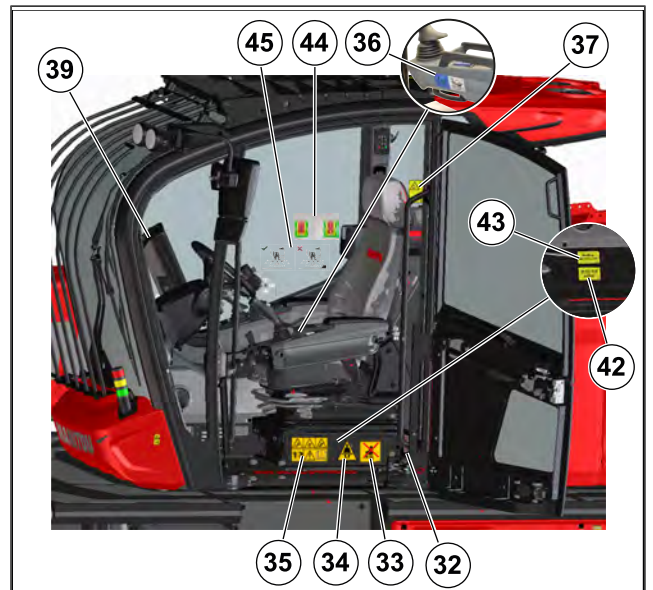


Figure 10: Decals - Location - Cabin

Table 2. Decals - Location

<b>Item</b>	<b>Part number</b>	<b>Description</b>	<b>Option</b>
1	659884 (IT) – 659888 (FR) – 672240 (EN) – 672241 (DE) – 659887 (ES)	1.12.1 Decals - Warning Open-center valve system, page 37 371.12.1 Decals - Warning Open-center valve system, page 37	
2	296998	1.12.2 Decal - Warning Prohibition to operators, page 37	
3	52633665	1.12.3 Decal — Danger Vehicle controlled by remote control, page 38	
4	716930	1.12.4 Decal - Warning Risk of investment / crushing, page 38	
5	52744587 (MRT 1645 / MRT-X 1645)		
	52744587 (MRT 1845 / MRT-X 1845)		
	52744588A (MRT 2145 / MRT-X 2145)		
	52754904 (MRT 2545 / MRT-X 2545)		
6	53017322	1.12.5 Decal - Notice Wheel nuts tightening torque, page 38	
7	52584177	1.12.6 Decal - Warning Pinch and nip points, page 38	
8	52744470	1.12.7 Decal - Danger It is forbidden to climb/descend the stairs, page 39	
9	52744452	1.12.8 Decal - Warning Safety locking device, page 39	
10	932095	1.12.9 Decal - Warning Moving parts, page 39	
11	52584234	1.12.44 Recharge of air conditioning system, page 47	
12	716906	1.12.10 Decal - Warning Fan in operation, page 39	
13	716925	1.12.11 Decal - Warning pressurized fluid, page 40	
14	716905	1.12.33 Decal - Warning Hot surfaces, page 45	
15	293887	1.12.12 Decal - Antifreeze fluid, page 40	
16	716926	1.12.13 Decal - Warning Pressurised system hot coolant, page 40	
17	716919	1.12.14 Decal - Caution Engine intake air filter, page 40	
18	716921	1.12.15 Decal - Danger Arc / Explosion, page 41	
19	53002561	1.12.16 Decal - Electrocuting hazard, page 41	
20	934222	1.12.17 Decal - Caution Battery, page 41	
21	296751A	1.12.18 Decal - Diesel type, page 41	
22	716907	1.12.19 Decal - Danger Flammable liquids, page 42	
23	716908A	1.12.37 Decal - Diesel tank, page 46	
24	52781588		
25	740478	1.12.41 Decal - Jump Start (vehicle), page 47	
26	932084	1.12.21 Decal - DEF tank, page 42	
27	932067	1.12.22 Decal - Hydraulic oil level, page 42	
28	716909A	1.12.23 Decal - Hydraulic oil tank, page 42	
29	52744473	1.12.35 Decal - Warning Transport of the vehicle, page 45	

Item	Part number	Description	Option
30	53027209	1.12.24 Decal - Notice high pressure washer, page 43	
31	672067	1.12.25 Decal - Explosion hazard, page 43	
32	932117	1.12.40 Decal - Warning ROPS-FOPS Fitted Do not drill or weld, page 47	
33	716917	1.12.26 Decal - Caution It is forbidden to transport of people, page 43	
34	732107	1.12.27 Decal - Caution Fasten seat belt, page 43	
35	52744474	1.12.38 Decal - Warning Maintain 3 points contact, page 46	
36	52742852	1.12.42 Prohibition / obligation to lift the driving seat armrest, page 47	
37	52744513	1.12.28 Decal - Warning Risk of rollover, page 44	
38	930780 (EN) (FR (DE) (NL)	1.12.36 Decal - Forbidden cross the machine's working area, page 46	X
39	930788 (EN) (FR (DE) (NL)	1.12.43 Decal - Black box system, page 47	X
40	53024729	1.12.39 Decal - Danger Boom safety wedge, page 46	X
41	53024733	1.12.29 Decal - Caution Pressurized vessel, page 44	X
42	53024943A	1.12.30 Decal - Caution No insulated platform, page 44	
43	53024944	1.12.31 Decal - Use Manitou approved tyre only, page 44	X
44	53025262	1.12.32 Decal - Caution No go zone for power lines, page 45	X
45	52611951		
46	672068	1.12.45 Decal - Warning Crushing of hands, page 47	

## 1.12. DECALS DESCRIPTION

### 1.12.1 DECALS - WARNING OPEN-CENTER VALVE SYSTEM



Figure 11: Decals - Warning Open-center valve system

**⚠ DANGER**

Indicates that the machine is equipped with open-center valve system make sure that the accessories mounted are fitted with a safety locking valve.

### 1.12.2 DECAL - WARNING PROHIBITION TO OPERATORS



Figure 12: Decal - Warning Prohibition to operators

**⚠ DANGER**

#### Risk of falling or crushing

It is prohibition for operators to climb onto the vehicle forks equipment to work or use it as a lift for the people. It is prohibition to stay under the vehicle forks equipment.

### 1.12.3 DECAL — DANGER VEHICLE CONTROLLED BY REMOTE CONTROL



Figure 13: Danger Vehicle controlled by remote control

**⚠ DANGER**

#### Risk of investment!

During the operation of the vehicle, do not approach.

### 1.12.4 DECAL - WARNING RISK OF INVESTMENT / CRUSHING



Figure 14: Decal - Warning Risk of investment / crushing

**⚠ WARNING**

#### Risk of investment / crushing.


During the operation of the vehicle, do not approach until it stops.


### 1.12.5 DECAL - NOTICE WHEEL NUTS TIGHTENING TORQUE



Figure 15: Decal - Notice Wheel nuts tightening torque

Indicates the value of the wheel nuts tightening torque.

 680 Nm (502 lb·ft)

 The "Nm - lb·ft" values vary according to the vehicle model.

### 1.12.6 DECAL - WARNING PINCH AND NIP POINTS



Figure 16: Decal - Warning Pinch and nip points

**⚠ WARNING**

#### Risk of pinch and nip.

During the operation of the vehicle boom, do not approach the telescopic booms.

### 1.12.7 DECAL - DANGER IT IS FORBIDDEN TO CLIMB/DESCEND THE STAIRS



Figure 17: Decal - Danger It is forbidden to climb/descend the stairs

**⚠ DANGER**

#### Risk of falling

Fall hazard.  
Floor-level obstacle hazard.  
Slippery surface hazard.  
It is forbidden to climb and descend the stairs.  
Read the Instructions manual.

### 1.12.8 DECAL - WARNING SAFETY LOCKING DEVICE



Figure 18: Decal - Warning Safety locking device

**⚠ WARNING**

#### Risk of crushing.

Crushing of whole body.  
During the vehicle maintenance operations under the boom it is necessary install the safety device on the lifting cylinder to lock it and prevent the boom accidental descent.

### 1.12.9 DECAL - WARNING MOVING PARTS



Figure 19: Decal - Warning Moving parts

**⚠ WARNING**

#### Warning, moving parts.

Risk of cutting and crushing.  
Do not attempt to adjust machine while it is running. Keep away the hands and body from moving parts.

Indicates the hazard during the access to moving parts of the vehicle due to opening of engine bonnet.

### 1.12.10 DECAL - WARNING FAN IN OPERATION



Figure 20: Decal - Warning Fan in operation

**⚠ WARNING**

#### Risk of entanglement, fan in operation.

Do not put your hands near the fan blades.

Indicates the hazard for the fan in operation and do not put your hands near the fan blades

### 1.12.11 DECAL - WARNING PRESSURIZED FLUID



Figure 21: Decal - Warning pressurized fluid

#### ⚠ WARNING

#### Warning, pressurized fluid.

Risk of skin injection. Failure to follow this warning can result in amputation or serious injury.

Relieve pressure before disconnecting hydraulic or other lines and tighten all connections before applying pressure. Protect hands and body from high pressure fluids.

In case of accidental skin injection, seek immediate surgical treatment.

### 1.12.12 DECAL - ANTIFREEZE FLUID

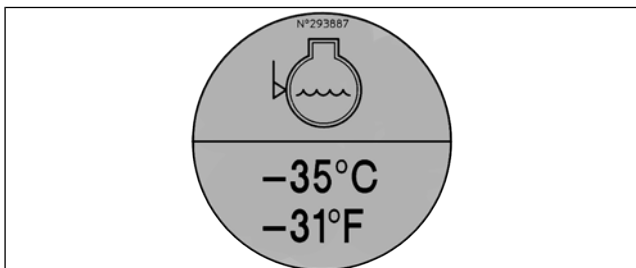


Figure 22: Decal - Antifreeze fluid

Indicates the position of the antifreeze fluid level and the freezing temperature of the fluid (-35°C - 31°F).

### 1.12.13 DECAL - WARNING PRESSURISED SYSTEM HOT COOLANT

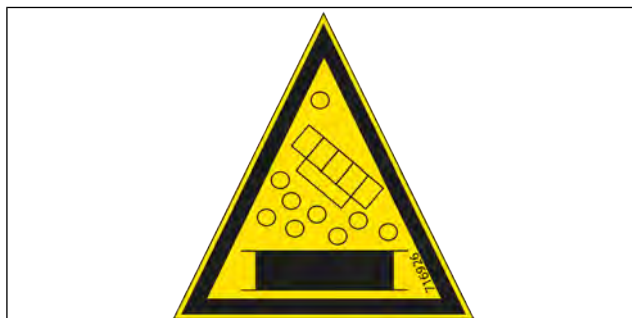


Figure 23: Decal - Warning Pressurised system hot coolant

#### ⚠ WARNING

#### Warning Pressurised system hot coolant.

Risk of burning and scalding.

Stop engine, wait until radiator is cool, then loosen cap slowly to relieve pressure.

### 1.12.14 DECAL - CAUTION ENGINE INTAKE AIR FILTER



Figure 24: Decal - Caution Engine intake air filter

#### ⚠ DANGER

#### Caution, engine intake air filter.

Indicates the presence and position of the engine intake air filter under the bonnet.

### 1.12.15 DECAL - DANGER ARC / EXPLOSION



Figure 25: Decal - Danger Arc / Explosion

**⚠ DANGER**

#### Dangers of an arc flash, including explosion.

Risks of severe injuries such as burns, blindness, or even blunt damage from the blast.

There is a danger of explosion if the battery is incorrectly replaced. Follow the workplace safety practices.

### 1.12.16 DECAL - ELECTROCUTION HAZARD



Figure 26: Decal - Warning Electrocution

**⚠ DANGER**

#### Risk of electrocution.

Serious injuries.

Do not touch. Disconnect all power sources before servicing.

### 1.12.17 DECAL - CAUTION BATTERY

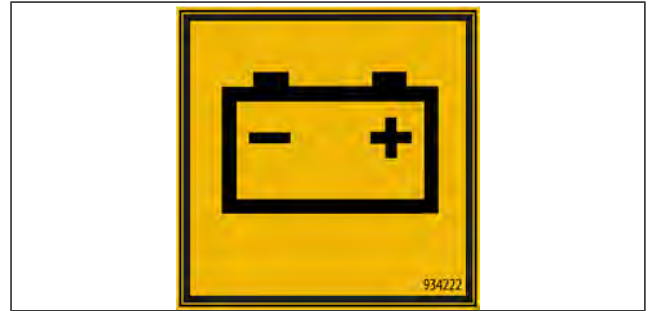


Figure 27: Decal - Caution Battery

**⚠ DANGER**

#### Caution Battery.

No Open Flames, Smoking Or Ignition Sources Permitted. Keep away. No open flames, smoking or ignition sources permitted near battery.

Indicates the position of the battery compartment.

### 1.12.18 DECAL - DIESEL TYPE



Figure 28: Decal - Diesel type

Indicates of features of recommended fuel. Only refuel using commercially available, sulphur-free diesel fuel that complies at the following standards:

- EN 590 on 2010 version et seq. (max sulphur component: 0.001% by weight) (10 ppm) or
- ASTM D975 (max sulphur component: 0.0015% by weight) (15 ppm).

### 1.12.19 DECAL - DANGER FLAMMABLE LIQUIDS



Figure 29: Decal - Danger Flammable liquids

**⚠ DANGER**

#### Danger Flammable liquids.

Risks of severe injuries.

Keep fire away. No smoking, no open flames, no sparks near the diesel tank.

### 1.12.20 DECAL - CAUTION BATTERY MASTER SWITCH

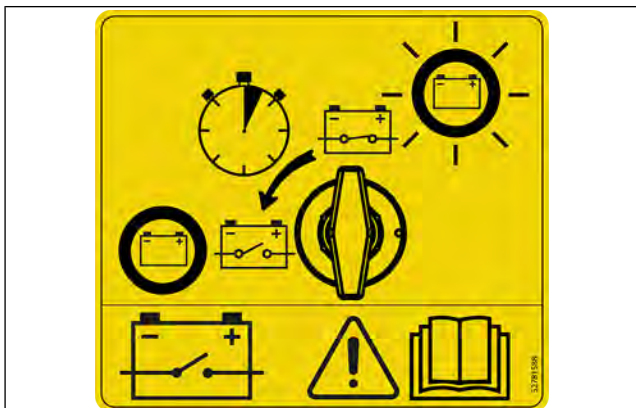


Figure 30: Decal - Caution Battery master switch

**⚠ DANGER**

#### Caution, Battery master switch.

Failure to disconnect all power before servicing can cause severe personal injury or death.

Disconnect electric power before servicing. Follow proper procedures to ensure the power cannot be inadvertently energized.

Indicates the position of the battery master switch and its function.

### 1.12.21 DECAL - DEF TANK



Figure 31: Decal - DEF tank

Indicates the DEF tank and fill neck.

### 1.12.22 DECAL - HYDRAULIC OIL LEVEL



Figure 32: Decal - Hydraulic oil level

Indicates the position for the hydraulic oil level indicator.

### 1.12.23 DECAL - HYDRAULIC OIL TANK



Figure 33: Decal - Hydraulic oil tank

Indicates the hydraulic oil tank and fill neck.

### 1.12.24 DECAL - NOTICE HIGH PRESSURE WASHER

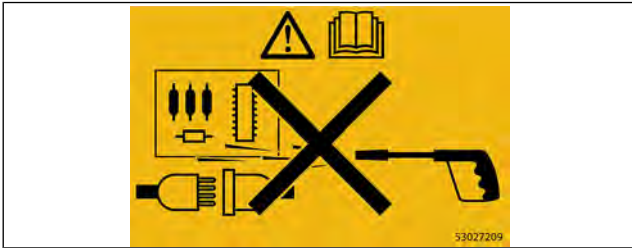



Figure 34: Decal - Notice high pressure washer

Indicates that the instruction manual must be read before using the machine.

It is strictly forbidden to direct a pressure washer nozzle over the control panels and electrical components.

 Refer to the corresponding chapter.

### 1.12.25 DECAL - EXPLOSION HAZARD



Figure 35: Decal - Explosion hazard

**⚠ DANGER**

**Explosion hazard. Vessel under pressure.**

High pressure can cause injury or death. Do not allow flames or sparks and do not smoke near the pressurized vessel during maintenance.

### 1.12.26 DECAL - CAUTION IT IS FORBIDDEN TO TRANSPORT OF PEOPLE



Figure 36: Decal - Caution It is forbidden to transport of people

**⚠ DANGER**

**Caution It is forbidden to transport of people.**

Risk of falling and crushing.

### 1.12.27 DECAL - CAUTION FASTEN SEAT BELT



Figure 37: Decal - Caution Fasten seat belt

**⚠ DANGER**

**Caution Fasten seat belt**

It is mandatory to fast the safety belt when driving the vehicle.

### 1.12.28 DECAL - WARNING RISK OF ROLLOVER



Figure 38: Decal - Warning Risk of rollover

#### **⚠ WARNING**

**Risk of rollover during the loading and moving the vehicle onto a load platform by using the radio remote control.**

Rollovers could result in death or serious injuries. Keep away from the vehicle in movements. Avoid abrupt maneuvers and excessive speed. See Instructions manual for further informations.

### 1.12.29 DECAL - CAUTION PRESSURIZED VESSEL

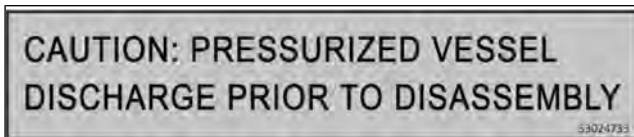


Figure 39: Decal - Caution Pressurized vessel

#### **⚠ DANGER**

#### **Risk of skin injection**

Failure to follow this warning can result in amputation or serious injury.

Relieve pressure before disconnecting hydraulic or other lines and tighten all connections before applying pressure. Protect hands and body from high pressure fluids. In case of accidental skin injection, seek immediate surgical treatment.

### 1.12.30 DECAL - CAUTION NO INSULATED PLATFORM



Figure 40: Decal - Caution No insulated platform

#### **⚠ DANGER**

#### **Electrocution hazard.**

This vehicle is not insulated. Death or serious injury will result from contact with or inadequate clearance from energized conductors.

Maintain safe clearances from electrical power lines and apparatus. You must allow for platform sway. Rock, or sag.

### 1.12.31 DECAL - USE MANITOU APPROVED TYRE ONLY



Figure 41: Decal - Use Manitou approved tyre only

Indicates that it is recommended to use only MANITOU approved tyres.

## 1.12.32 DECAL - CAUTION NO GO ZONE FOR POWER LINES

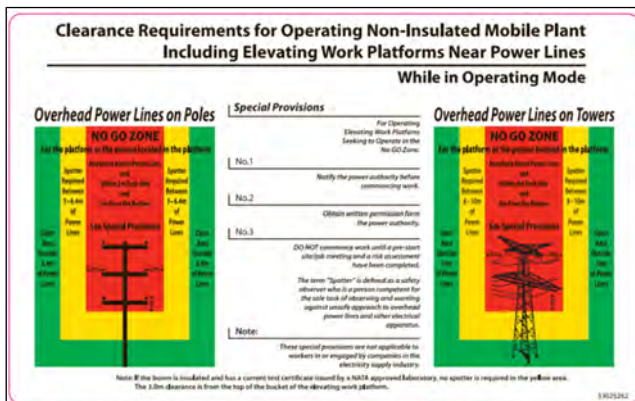


Figure 42: Decal - Caution No go zone for power lines

### ⚠ DANGER

Indicates the clearance requirements for operating Non-Insulated mobile plant Including elevating work platforms near power lines.

## 1.12.33 DECAL - WARNING HOT SURFACES



Figure 43: Decal - Warning Hot surfaces

### ⚠ WARNING

Warning, hot surfaces.

Risk of scalding and burning.

Do not touch.

Stay away from hot surfaces (engine, exhaust manifold gas, etc.).

## 1.12.34 DECAL - NOTICE STABILIZERS PRESSURE ON THE GROUND

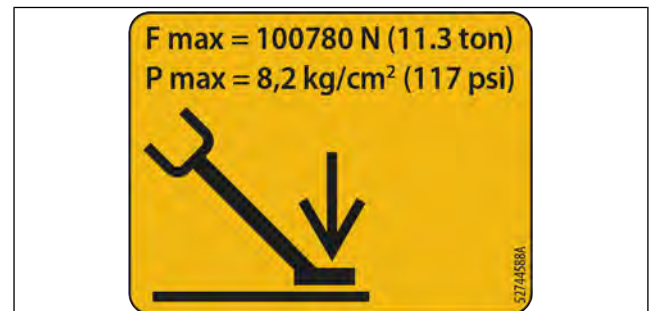



Figure 44: Decal - Notice Stabilizers pressure on the ground

Indicates the maximum force of the stabilizers exerted on the ground ( $F_{max} = 100780 \text{ N} — 11.3 \text{ ton}$ ) and the maximum pressure of the stabilizers exerted on the ground ( $P_{max} = 8,2 \text{ kg/cm}^2 — 117 \text{ psi}$ ).

 The “ $F_{max}$  and  $P_{max}$ ” values vary according to the vehicle model.

## 1.12.35 DECAL - WARNING TRANSPORT OF THE VEHICLE



Figure 45: Decal - Warning Transport of the vehicle

### ⚠ WARNING

Warning Transport of the vehicle.

Risk of vehicle rollover. Can cause severe injury or death.

Before transporting the vehicle on a trailer, it is mandatory to lock the turret rotation with the safety pin. Read the operator's manual.

### 1.12.36 DECAL - FORBIDDEN CROSS THE MACHINE'S WORKING AREA



Figure 46: Decal - Forbidden cross the machine's working area

**⚠ DANGER**

**Forbidden cross the machine's working area.**

Keep away during the movements of vehicle.

### 1.12.37 DECAL - DIESEL TANK



Figure 47: Decal - Diesel tank

Indicates the diesel tank and fill neck.

### 1.12.38 DECAL - WARNING MAINTAIN 3 POINTS CONTACT



Figure 48: Decal - Warning Maintain 3 points contact

**⚠ WARNING**

**Warning Maintain 3 points contact.**

Slip, trip, and fall hazard.

Maintain 3 point of contact when entering or exiting vehicle.

Never jump Off the vehicle.

Climb up forward.

Down backwards.

Ensure the steps are clean.

### 1.12.39 DECAL - DANGER BOOM SAFETY WEDGE



Figure 49: Decal - Danger Boom safety wedge

**⚠ DANGER**

**Risk of crushing.**

The safety wedge must be installed by accessing the walkable surface of the undercarriage from the right side staircase. During installation of the safety wedge, do not stand under the telescopic boom.

Read the instruction manual.

The safety wedge which prevents accidental descent of the telescopic boom during maintenance operations of the same or in the areas below it.

### 1.12.40 DECAL - WARNING ROPS-FOPS FITTED DO NOT DRILL OR WELD



Figure 50: Decal - Warning ROPS-FOPS Fitted Do not drill or weld



Warning Do not drill, weld, or make any other modifications to the ROPS/FOPS.

### 1.12.41 DECAL - JUMP START (VEHICLE)



Figure 51: Decal - Jump Start (vehicle)

Indicates points for the jump start.

### 1.12.42 PROHIBITION / OBLIGATION TO LIFT THE DRIVING SEAT ARMREST



Figure 52: Prohibition / obligation to lift the driving seat armrest.

Indicates that it is mandatory lift the left armrest of driving seat though the handle in front of the armrest. Lift the armrest in another points can damage it.

### 1.12.43 DECAL - BLACK BOX SYSTEM



Figure 53: Decal - Black box system



Warning, the system is equipped with a data recording device.

### 1.12.44 RECHARGE OF AIR CONDITIONING SYSTEM



Figure 54: Recharge of air conditioning system

Indicates the type (R134a) and quantity (1600 g) of the refrigerant gas necessary to recharge the air conditioning system. Read the instructions manual.

### 1.12.45 DECAL - WARNING CRUSHING OF HANDS



Figure 55: Warning Crushing of hands



**Risk of crushing of hands.**

Injury to hands.

Taking care to hands when in the vicinity of the vehicle with motion or closing mechanical parts.



## 2. TECHNICAL DATA AND DESCRIPTION

### 2.1. MACHINE IDENTIFICATION

#### 2.1.1 MANUFACTURER'S PLATE

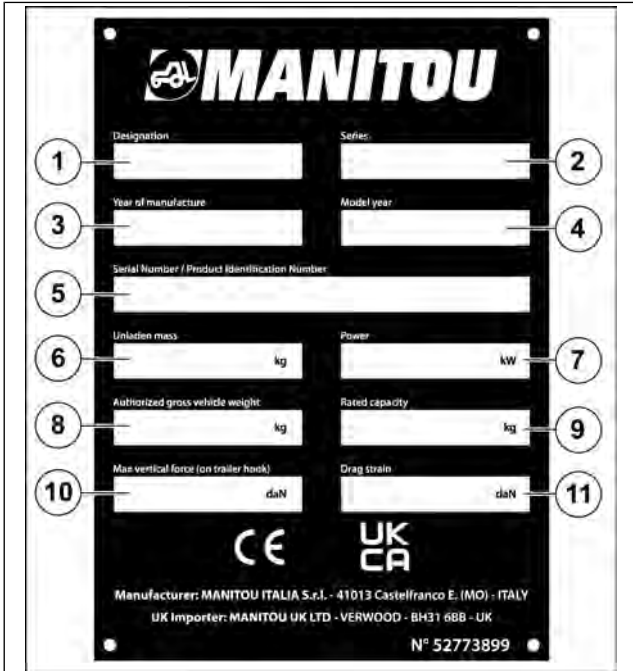


Figure 56: Manufacturer's Plate

Table 3. Manufacturer's Plate

Ref.	Description	
1	Model	
2	Series	
3	Year of manufacture	
4	Year model	
5	Serial No.	
6	Unladen mass	
7	Power ISO / TR 14396	
8	Total Permitted Working Weight	
9	Nominal capacity	
10	Maximum lift capacity (on the towing hook)	
11	Drawbar pull	

#### 2.1.2 VEHICLE IDENTIFICATION

In order to make constant improvements to our products, some changes can be made to our range of vehicles, without any obligation to inform our customers on our part.

For each spare part order or for each request for technical information, it is necessary to specify the following information.



*In order to communicate all the numbers more easily, it is recommended to write them in the appropriate spaces upon delivery of the vehicle*

#### 2.1.3 HEAT ENGINE PLATE



Figure 57: Heat engine plate

Table 4. Heat engine plate

1	Model	
2	Engine code	
3	Engine number	

#### 2.1.4 HYDROSTATIC PUMP PLATE

Only for Rexroth pumps

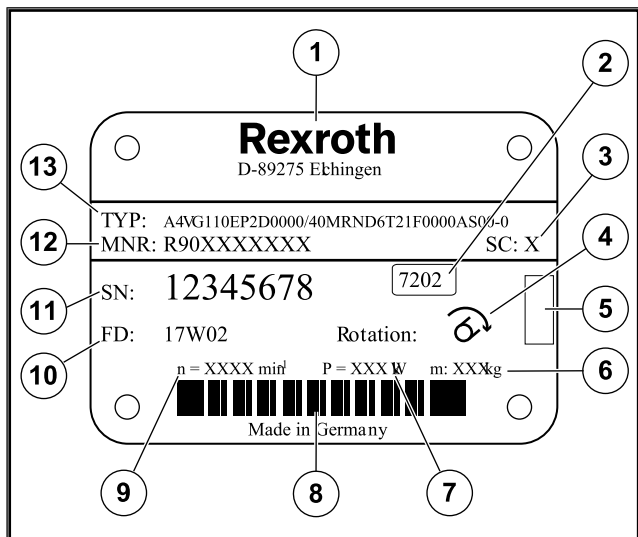


Figure 58: Hydrostatic pump plate

Table 5. Hydrostatic pump plate

1	Manufacturer	
2	Indoor plant designation	
3	Category (optional)	
4	Direction of rotation (seen on the motor shaft) - here: clockwise	
5	Specific area for inspection marking	
6	Weight (optional)	
7	Power	
8	Bar code	
9	Rotation speed	
10	Manufacturing date	
11	Serial number	
12	Material code of the axial piston unit	
13	Ordering code	

## 2.1.5 HYDROSTATIC MOTOR PLATE

### HYDROSTATIC MOTOR PLATE

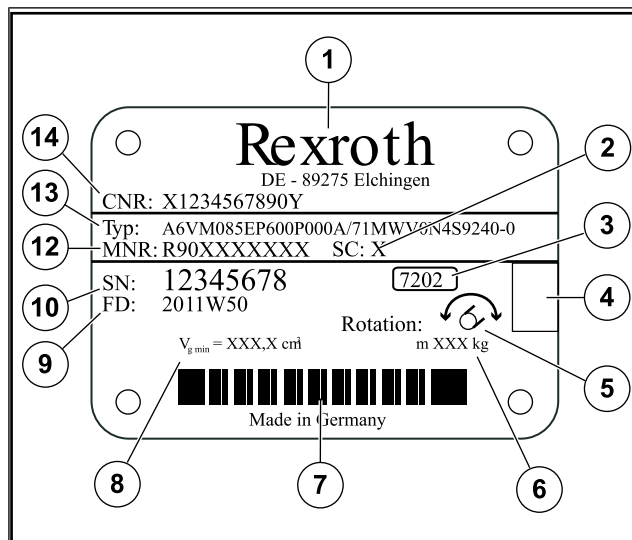


Figure 59: Hydrostatic motor plate

Table 6. Hydrostatic motor plate

1	Manufacturer	
2	Indoor plant designation	
3	Category (optional)	
4	Direction of rotation (seen on the motor shaft) - here: clockwise	
5	Specific area for inspection marking	
6	Weight (optional)	
7	Power	
8	Bar code	
9	Rotation speed	
10	Manufacturing date	
11	Serial number	
12	Material code of the axial piston unit	
13	Ordering code	
14	Customer material number	

### 2.1.6 GEARBOX PLATE

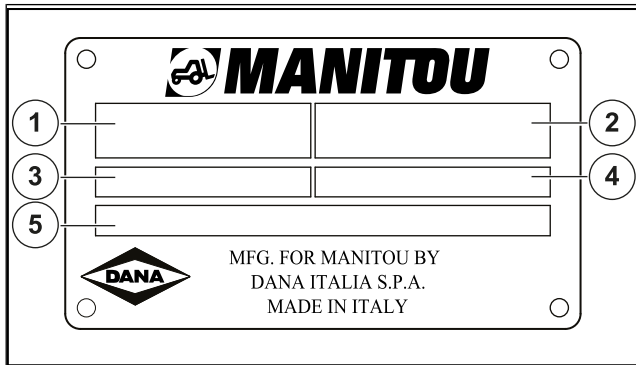


Figure 60: Gearbox plate

Table 7. Gearbox plate

Ref.	Description	
1	Group type and model	
2	Serial No.	
3	MANITOU Reference	
4	Index of alteration	
5	Lubricant	

### 2.1.7 CHASSIS PLATE



Figure 61: Chassis plate

Table 8. Chassis plate

Ref.	Description	
1	Serial number / Product ID number	

## 2.1.8 ACCESSORY MANUFACTURER'S PLATE

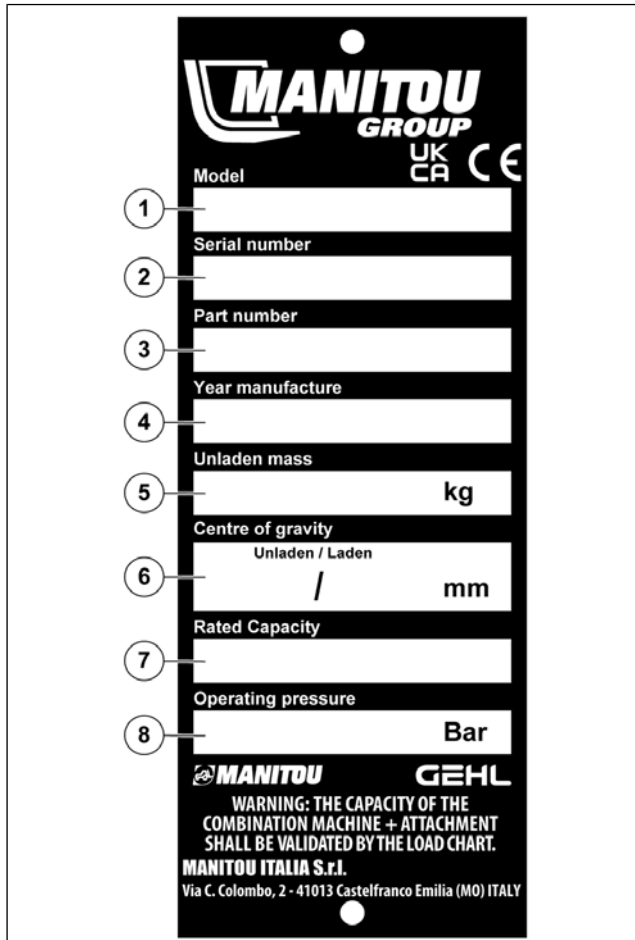


Figure 62: Accessory manufacturer's plate

Table 9. Accessory manufacturer's plate

Ref.	Description	
1	Model	
2	Serial number	
3	Attachment identification code	
4	Year of manufacture	
5	Unladen mass	
6	Center of gravity	
7	Nominal capacity	
8	Service pressure	

## 2.1.9 FRONT AXLE PLATE

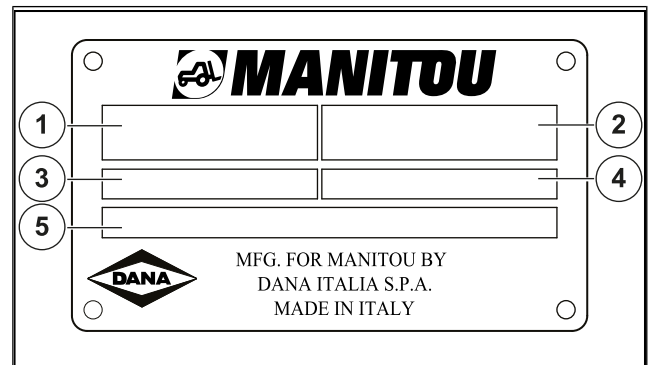


Figure 63: Front axle plate

Table 10. Front axle plate

Ref.	Description	
1	Group type and model	
2	Serial No.	
3	MANITOU Reference	
4	Index of alteration	
5	Lubricant	

## 2.1.10 REAR AXLE PLATE

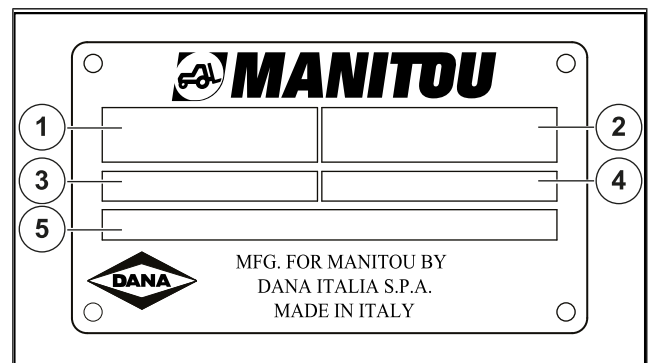


Figure 64: Rear axle plate

Table 11. Rear axle plate

Ref.	Description	
1	Group type and model	
2	Serial No.	
3	MANITOU Reference	
4	Index of alteration	
5	Lubricant	

### 2.1.11 CABIN PLATE

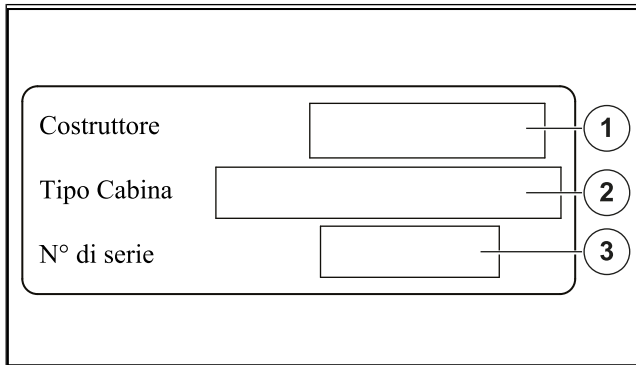


Figure 65: Cabin plate

Table 12. Cabin plate

Ref.	Description	
1	Manufacturer	
2	Cabin type	
3	Serial No.	

## 2.2. TECHNICAL SPECIFICATIONS

### 2.2.1 EC DECLARATION OF CONFORMITY



*This document is an example of the EC declaration of conformity, which has the same content as the original declaration provided with the machine.*

*This example and the original document may contain data fields which do not apply to the machine. These fields are left blank if not relevant.*

*Refer to the original declaration of conformity for all relevant data for your machine.*

1) **DÉCLARATION «CE» DE CONFORMITÉ (originale)**  
**«EC» DECLARATION OF CONFORMITY (original)**

2) Constructeur, *Manufacturer* : **MANITOU BF**  
3) Adresse, *Address* : **430, RUE DE L'AUBINIÈRE - B.P 10249**  
**44158 - ANCENIS - CEDEX - FRANCE**

4) Titulaire du dossier technique, *Holder of the technical file* : **MANITOU BF**  
3) Adresse, *Address* : **430, RUE DE L'AUBINIÈRE - B.P 10249**  
**44158 - ANCENIS - CEDEX - FRANCE**

5) Le constructeur déclare que la machine décrite ci-après, *The manufacturer declares that the machine described below* :

**Nom générique machine**

XXXXXXXXXXXXXX	XXXXXXXXXXXXXX
XXXXXXXXXXXXXX	XXXXXXXXXXXXXX
XXXXXXXXXXXXXX	XXXXXXXXXXXXXX
XXXXXXXXXXXXXX	XXXXXXXXXXXXXX
XXXXXXXXXXXXXX	XXXXXXXXXXXXXX
XXXXXXXXXXXXXX	XXXXXXXXXXXXXX
XXXXXXXXXXXXXX	XXXXXXXXXXXXXX

6) Est conforme aux directives suivantes et à leurs transpositions en droit national (si applicables),  
*Complies with the following directives and their transpositions into national law (if applicable)* :

**2006/42/CE**

7) Pour les machines annexe IV, *For annex IV machines* : Non applicable  
8) Numéro d'attestation, *Certificate number* : Non applicable  
9) Organisme notifié, *Notified body* : Non applicable

**2000/14/CE + 2005/88/CE**

10) Procédure appliquée, *Applied procedure* : ANNEXE  
9) Organisme notifié, *Notified body* : ORGANISME  
ADRESSE LIGNE 1  
ADRESSE LIGNE 2

11) Niveau de puissance acoustique, *Sound power level* :

12) Mesuré, <i>Measured</i> :	dB (A)
13) Garanti, <i>Guaranteed</i> :	dB (A)

**2014/30/UE**

14) Normes harmonisées utilisées, *Harmonised standards used* :  
ENXXX  
15) Normes ou dispositions techniques utilisées, *Standards or technical provisions used* :  
ENXXX

16) Fait à, *Done at* : 17) Date, *Date* :  
18) Nom du signataire, *Name of signatory* :  
19) Fonction, *Function* :  
20) Société, *Company* :  
21) Signature, *Signature* :

Figure 66: EC declaration of conformity - example 1/2

**bg :** (1) „ЕО“ декларация за съответствие (оригинал), (2) Производител, (3) Адрес, (4) Притежател на техническото досие, (5) Производителът декларира, че описаната по-долу машина, (6) Е в съответствие със следните директиви и тяхното транспониране в националното законодателство (ако е приложимо), (7) Приложение IV отнсно машините, (8) Номер на сертификата, (9) Нотифициран орган, (10) Приложена процедура, (11) Ниво на силата на звука, (12) Измерено, (13) Гарантирано, (14) Използвани хармонизирани стандарти, (15) Използвани стандарти или технически разпоредби, (16) Изработено в, (17) Дата, (18) Име на подписаното лице, (19) Длъжност, (20) Фирма, (21) Подпис

**ca :** (1) ES prohlášení o shodě (původně), (2) Výrobce, (3) Adresa, (4) Držitel technické dokumentace, (5) Výrobce prohlašuje, že zařízení porouká níže, (6) Je v souladu s následujícími směrnici a směrnici transponovanými do vnitrostátního práva (je-li relevantní), (7) Pro stroje v příloze IV(8) Číslo certifikátu, (9) Notifikační orgán, (10) Použitý postup, (11) Úroveň hluku (12) Naměřené, (13) Zaručené, (14) Použitá harmonizované normy, (15) Použitá normy nebo technické předpisy(16) Místo (17) Datum (18) Jméno podepsaného, (19) Funkce, (20) Společnost, (21) Podpis

**da :** (1) EF-overensstemmelseserklæring (original), (2) Producent, (3) Adresse, (4) Indehaver af det tekniske dossier, (5) Producenten erklærer, at maskinen, der er beskrevet nedenfor, (6) overholder nedennævnte direktiver og disse gennemførelses i national ret (hvis det er relevant), (7) For maskiner under bilag IV, (8) Certificatnummer, (9) Bemyndigede organ, (10) Anvendt procedure, (11) Lydniveau, (12) Målt, (13) Garanti, (14) Anvendte harmoniserede standarder, (15) Standarder eller tekniske regler, (16) Udfærdiget i, (17) Dato, (18) Underskrivers navn, (19) Funktion, (20) Firma, (21) Underskrift.

**de :** (1) EG-Konformitätserklärung (original), (2) Hersteller, (3) Adresse, (4) Inhaber des technischen Dossiers, (5) Der Hersteller erklärt, dass die nachstehend beschriebene Maschine (6) den folgenden Richtlinien und deren Umsetzung in die nationale Gesetzgebung entspricht (falls anwendbar), (7) Für die Maschinen laut Anhang IV, (8) Bescheinigungsnummer, (9) Benannte Stelle, (10) Angewandtes Verfahren, (11) Schalleistungspegel, (12) Gemessen, (13) Gewährleistet, (14) angewandte harmonisierte Normen, (15) angewandte sonstige technische Normen und Bestimmungen, (16) Ausgestellt in, (17) Datum, (18) Name des Unterzeichners, (19) Funktion, (20) Gesellschaft, (21) Unterschrift.

**el :** (1) Δήλωση συμμόρφωσης CE (πρωτότυπο), (2) Κατασκευαστής, (3) Διεύθυνση, (4) Κάτοχος του τεχνικού φακέλου, (5) Ο κατασκευαστής δηλώνει ότι το μηχάνημα που περιγράφεται παρακάτω, (6) Συμμορφώνεται με τις εξής οδηγίες και τις προσαρμογές τους στο εθνικό δίκαιο (κατά περίπτωση), (7) Για τα μηχανήματα του παραρτήματος IV, (8) Αριθμός πιστοποιητικού, (9) Διοικουμένος φορέας, (10) Εφαρμοζόμενη διαδικασία, (11) Επίπεδο ηχητικής ισχύος, (12) Καταμετρημένη, (13) Εγγυημένη, (14) Εναρμονισμένα πρότυπα που χρησιμοποιούνται, (15) Πρότυπα ή τεχνικοί κανόνες που χρησιμοποιούνται, (16) Τόπος, (17) Ημερομηνία, (18) Όνομα του υπογράφοντος, (19) Ιδιότητα, (20) Εταιρεία, (21) Υπογραφή

**es :** (1) Declaración CE de conformidad (original), (2) Fabricante, (3) Dirección, (4) Titular del expediente técnico, (5) El fabricante declara que la máquina que se describe a continuación, (6) Cumple con las siguientes directivas y sus transposiciones a la legislación nacional (en caso oportuno), (7) Para las máquinas anexo IV, (8) Número de certificación, (9) Organismo notificado, (10) Procedimiento aplicado, (11) Nivel de potencia acústica, (12) Medido, (13) Garantizado, (14) Normas armonizadas utilizadas, (15) Otras normas o especificaciones técnicas utilizadas, (16) Hecho en, (17) Fecha, (18) Nombre del signatario, (19) Cargo, (20) Empresa, (21) Firma.

**et :** (1) EÜ vastavusdeklaratsioon (algversioon), (2) Tootja, (3) Aadress, (4) Tehnilise dokumentatsiooni valdaja, (5) Tootja kinnitab, et allpool kirjeldatud seade, (6) On vastavusse järgmistele direktiivide ja nende rakendamisele õigusse ülevõtmiseks võetud õigusaktidega (seda on kohaldatav), (7) IV lisas loetud seadmete puhul, (8) Tunnistuse number, (9) Serifitseerimisasutus, (10) Kohaldatav menetlus, (11) Akustilise võimsuse tase, (12) Mõeldud, (13) Tagatud, (14) Vastab kehtivatele ühistatutud standarditele, (15) Vastab muudele kehtivatele standarditele ja tehnilistele normidele, (16) Väljaandmise koht, (17) Väljaandmise aeg, (18) Allkirjastaja nimi, (19) Amet, (20) Ettevõtte, (21) Allkiri

**fi :** (1) EY-vastavusdeklarationi alkuperäinen versio (alkuperäinen), (2) Valmistaja, (3) Osoite, (4) Teknisten asiakirjojen haltaja, (5) Valmistaja ilmoittaa, että alla kuvattu laite, (6) Täyttää seuraavien direktiivien sekä niissä vastavien kansallisten säännösten vaatimukset (tarvittaessa), (7) Liitteen IV listattuihin osiin, (8) Todistusnumero, (9) Ilmoittaja laitos, (10) Käytetty menettelytapa, (11) Äänen taso, (12) Mittattu, (13) Takuu, (14) Käytetyt yhdenmukaistetut standardit, (15) Käytetyt tekniset standardit tai säännökset, (16) Paikka, (17) Aika, (18) Allekirjoittajan nimi, (19) Toimisto, (20) Yhteyshenkilö, (21) Allekirjoitus.

**ga :** (1) Dearbhán comhréimíochta « CE » (bunaidh), (2) Déantóir, (3) Seoladh, (4) Saibhóir an chomhaid theicniúil, (5) Dearbhainn an deantóir go ndéanann an t-inneal ar a bhfuil cur síos thíos, (6) Cloíonn sé le na teoiricí seo a leanas agus lena draoiúl isteach i nriailiúna (más cuil), (7) Le haghaidh innill an aghaisín IV, (8) Uimhir leasaithe, (9) Comhlach a dtagtar fógra dó, (10) Níos ísle ná a rialaigh i bhfeidhm, (11) Leibhéil cumhachta na fuaimne, (12) Tomhasa, (13) Ráthaithe, (14) Cairdeáin chomhréimíochta a tsáidísíod, (15) Cairdeáin nó fóirteacha teicniúla a tsáidísíod, (16) Ainm dheantóir ag, (17) Dáta, (18) Ainm an tsáidísíora, (19) Feidhmeannas, (20) Comhlach (21) Síniú.

**hr :** (1) EK deklaracija o usklađenosti (original), (2) Proizvođač, (3) Adresa (4) Nositelj tehničke dokumentacije, (5) Proizvođač izjavlja da stroj opisan u nastavku, (6) Ispunjava aljedeće direktive i njihovom prijenosu u nacionalno zakonodavstvo (ako je primjenjivo), (7) Za dodatka IV o strojevima, (8) Broj certifikata, (9) Ovlašteno tijelo, (10) Primjenjeni postupak, (11) Razina snage zvuka, (12) Izmjereno, (13) Zajamčeno, (14) Primjenjeni standardi o harmoniziranju, (15) Primjenjeni standardi ili tehničke priloge, (16) Urađeno u, (17) Datum, (18) Ime potpisnika, (19) Funkcija, (20) Tvrtka, (21) Potpis.

**hu :** (1) CE megfelelőségi nyilatkozat (eredeti), (2) Gyártó, (3) Cím, (4) A műszaki dokumentáció birtokosa, (5) A gyártó kijelenti, hogy az alábbi termék, (6) Megfelel az alábbi irányelveknek valamint azok honosított előírásainak (ha vannak ilyenek), (7) A IV. melléklet gépéhez (adott esetben), (8) Bizonylati szám, (9) Értékelő szervezet, (10) Alkalmazott eljárás, (11) Akusztikus hang szint, (12) Mért, (13) Garancia, (14) Felhasznált harmonizált szabványok, (15) egyéb felhasználható műszaki szabványok és előírások hivatkozásai, (16) Hely, (17) Dátum, (18) Aláíró neve, (19) Funkció, (20) Vállalat, (21) Aláírás

**ia :** (1) Sa conformitate declaracione originala FSE (originala), (2) Framleitor, (3) Adesura, (4) Handhafe tehnicala, (5) Framleitorul stafoarelor ad voin sa lyste er her, (6) Sa meste meste el firafrant stoculum e stafoarelor peira me hieiojor e ptoarotit (se ad a), (7) Fyir kastajonad IV, aduaca, (8) Numer votore, (9) Tikynnt el, (10) Adher bell, (11) Hiojortykur, (12) Masteid, (13) Ahyrg, (14) Sa meste meste stajlar som notari voru, (16) Adn stajlar eoa teknicala forskrif, (16) Stajur, (17) Dagsetning, (18) Nafn undirfrita, (19) Staja, (20) Fyirtasta, (21) Underskrift.

**it :** (1) Dichiarazione CE di conformità (originale), (2) Costruttore, (3) Indirizzo, (4) Titolare del fascicolo tecnico, (5) Il costruttore dichiara che la macchina descritta di seguito, (6) È conforme alle direttive seguenti e al relativo recepimento nella normativa nazionale (se applicabile), (7) Per le macchine Allegato IV, (8) Numero di Attestazione, (9) Organismo destinatario della notifica, (10) Procedura applicata, (11) Livello di potenza acustica, (12) Misurato, (13) Garantito, (14) Norme armonizzate applicate, (15) Norme e specifiche tecniche applicate, (16) Luogo, (17) Data, (18) Nome del firmatario, (19) Funzione, (20) Società, (21) Firma.

**lt :** (1) EÜ atitikties deklaracija (originalas), (2) Gamintojas, (3) Adresas, (4) Techninės bylos turėtojas, (5) Gamintojas nurodo, kad mašina, aprašyta žemiau, (6) atitinka toliau nurodytas direktyvas ir j nacionalinius teisės aktus perkelius jų nuostatas (jei taikytina), (7) IV priede d. mašinų, (8) Serifikato Nr., (9) Notifikuotoji įstaiga, (10) Taikytą procedūrą, (11) Garso stiprumo lygis, (12) Išmatuotas, (13) Garantuojamas, (14) Naudojami standartai, (15) Kitą naudoti standartai ir techninės specifikacijos, (16) Pasirašyta, (17) Data, (18) Pasirašiusio asmens vardas ir pavardė, (19) Pareigos, (20) Bendrovė, (21) Parašas

**lv :** (1) EK atbilstības deklarācija (originala), (2) Ražotājs, (3) Adrese, (4) Tehniskās dokumentācijas turētājs, (5) Ražotājs apliecinā, ka turpmāk aprakstītā mašīna, (6) Atbilst tālāk norādītajām direktīvām un to leģislatīvajai nacionālajai likumdošanai (ja piemērojama), (7) IV pielikuma lektārijā, (8) Serifikācija numurs, (9) Pilsnervoti iestāde, (10) Piemērotā procedūra, (11) Skapas laudes līmenis, (12) Izmērīts, (13) Garantēts, (14) Piemērojama saakopojuma, (15) Piemērojama tehniskie standarti un noteikumi, (16) Sastādīts, (17) Datums, (18) Parakstītāja vārds, (19) Amats, (20) Uzņēmums, (21) Paraksts

**mt :** (1) Deklarazzjoni ta' Konformita' ta' CE (originali), (2) Manifattur, (3) Indirizz, (4) Detentur tal-faj tekniku, (5) Il-manifattur jiddeklara li i-magna deskritta hawn taht, (6) Hija konformi hija konformi mad-Direttivi segwenti u l-idrijiet li jimplimentawhom fil-lij nazzjonali (jekk applikabbli), (7) Shall-magni li-Anness IV, (8) Numru tad-Certifikat, (9) Entita' notifika, (10) Proccedura applikata, (11) Livell ta' qawwa akustika, (12) Imkejl, (13) Garantit, (14) Istandards armonizzati uzatal, (15) standards tekniku u speccifikazzjonijiet oħra uzatal, (16) Mghadml f, (17) Data, (18) Ism il-firmatarju, (19) Kariga, (20) Kumpanja (21) Firma.

**nl :** (1) EÜ-overeenstemming van overeenstemming (oorspronkelijk), (2) Fabrikant, (3) Adres, (4) Houder van het technische dossier, (5) De fabrikant verklaart dat de hieronder beschreven machine, (6) In overeenstemming is met de volgende richtlijnen en hun omzettingen in het nationale recht (indien van toepassing), (7) Voor de machines in bijlage IV, (8) Certificatnummer, (9) Aangemelde instantie, (10) Toegestane procedure, (11) Geluidsvormingsniveau, (12) Gemeten, (13) Geгарantiseerd, (14) geharmoniseerde geharmoniseerde normen, (15) andere gehanteerde technische normen en specificaties, (16) Opgemaakt te, (17) Datum, (18) Naam van ondertekenaar, (19) Functie, (20) Onderneming, (21) Handtekening.

**no :** (1) CE-samsvarserklæring (original), (2) Producent, (3) Adresse, (4) Innehaveren av den tekniske dokumentasjonen, (5) Producenten sier at maskinen beskrevet nedenfor, (6) Oppfyller kravene i følgende direktiver og med nasjonale gjennomføringsbestemmelser (hvis aktuelt), (7) For maskinene i bilag IV, (8) Attestnummer, (9) Teknisk kontrollorgan, (10) Anvendt prosedyre, (11) Akustisk støy, (12) Målt, (13) Garantert, (14) harmoniserte standarder som brukes, (15) Andre standarder og spesifikasjoner som brukes, (16) Utstedt, (17) Dato, (18) Undertegnendes navn, (19) Stilling, (20) Firma (21) Underskrift

**pl :** (1) Deklaracja zgodności CE (oryginal), (2) Producent, (3) Adres, (4) Posiadacz dokumentacji technicznej, (5) Producent oświadcza, że opisana poniżej maszyna, (6) Jest zgodna z następującymi dyrektywami i odpowiedziami im przepisami prawa krajowego (jeśli dotyczy), (7) Dla maszyn załącznik IV, (8) Numer certyfikatu, (9) Jednostka certyfikująca, (10) Procedura stosowana, (11) Poziom mocy akustycznej, (12) Zmierzony, (13) Gwarantowany, (14) zastosowane normy zharmonizowane, (15) Zastosowane normy lub przepisy techniczne, (16) Sporządzono w, (17) Data, (18) Nazwisko podpisującego, (19) Stanowisko, (20) Firma (21) Podpis

**pt :** (1) Declaração de conformidade CE (original), (2) Fabricante, (3) Morada, (4) Titular do processo técnico, (5) O fabricante afirma que a máquina descrita abaixo, (6) Está em conformidade com as seguintes diretivas e as suas transposições para o direito nacional (se for o caso), (7) Para as máquinas no anexo IV, (8) Número de certificado, (9) Entidade notificada, (10) Procedimento aplicado, (11) Nível de potência acústica, (12) Medida, (13) Garantida, (14) normas harmonizadas utilizadas, (15) outras normas e especificações técnicas utilizadas, (16) Elaborado em, (17) Data, (18) Nome do signatário, (19) Cargo, (20) Empresa, (21) Assinatura

**ro :** (1) Declarație de conformitate CE (original), (2) Producător, (3) Adresa, (4) Titularul din dosarul tehnic, (5) Producătorul afirmă că aparatul descris mai jos, (6) Este conform cu directivele următoare și cu transpunerea lor în dreptul național (decă este cazul), (7) Pentru mașinile din anexa IV, (8) Număr de atestare, (9) Organism notificat, (10) Procedura aplicată, (11) Nivel de putere acustică, (12) Măsurat, (13) Garantat, (14) standardele armonizate utilizate, (15) alte standarde și specificații tehnice utilizate, (16) Intocmit în, (17) Data, (18) Numele persoanei care semnează, (19) Funcția, (20) Firma, (21) Semnătură

**sk :** (1) Vyhlásenie o zhode ES (původně), (2) Výrobce, (3) Adresa, (4) Držitel technické dokumentace, (5) Výrobce vyhlásuje, že nižšie popísaný stroj, (6) Je v súlade s nasledujúcimi smernicami a smernicami transponovanými do vnitrostátného práva (v prípade potreby), (7) Pre stroje v príloze IV, (8) Číslo certifikátu, (9) Notifikovaný orgán, (10) Použitý postup, (11) Akustická úroveň hluku, (12) Nameraná, (13) Zaručená, (14) Použitá harmonizované normy, (15) Iné použité normy a technické predpisy, (16) Miesto vydania, (17) Dátum vydania, (18) Mieno podpísanej osoby, (19) Funkcia, (20) Spoločnosť, (21) Podpis

**sl :** (1) EÜ izjava o skladnosti (izvirnik), (2) Proizvajalec, (3) Naslov, (4) Imetnik tehnične dokumentacije, (5) Proizvajalec izjavlja, da naprava, opisana v nadaljevanju, (6) Ustreza naslednjim direktivam in nacionalni zakonodaji (če to velja), (7) Za stroje v skladu s priložo IV, (8) Številka potrdila, (9) Priglasen organ, (10) Uporabljen postopek, (11) Raven akustične moči, (12) Izmerjena, (13) Zajamčena, (14) Uporabljeni usklajeni standardi, (15) Drugi uporabljeni tehnični standardi in specifikacije, (16) V, (17) Datum, (18) Ime podpisnika, (19) Funkcija, (20) Podjetje, (21) Podpis.

**sv :** (1) EÜ-försäkran om överensstämmelse (original), (2) Tillverkare, (3) Adress, (4) Ägaren av det tekniska underlaget, (5) Tillverkaren försäkrar att den maskin som beskrivs nedan, (6) Överensstämmer med nedanstående direktiv och införlivandet av dem i nationell rätt (om tillämpligt), (7) För maskinerna i bilaga IV, (8) Nummer för godkännande, (9) Anmält organ, (10) Förfarande som tillämpats, (11) Ljudtrycksnivå, (12) Uppmätt, (13) Garanterad (14) Harmoniserade standarder som använts, (15) andra tekniska standarder och specifikationer som använts, (16) Upprättat i, (17) Datum, (18) Namn på den som undertecknat, (19) Befattning, (20) Företag (21) Namnteckning

Figure 67: EC declaration of conformity - example 2/2

## 2.2.2 UKCA DECLARATION OF CONFORMITY



*This document is an example of UKCA declaration of conformity, which has the same content as the original declaration provided with the machine.*

*This example and the original document may contain data fields which do not apply to the*

*machine. These fields are left blank if not relevant.*

*Refer to the original declaration of conformity for all relevant data for your machine.*

## UKCA DECLARATION OF CONFORMITY

Manufacturer: **MANITOU BF**  
 Address: **430, RUE DE L'AUBINIÈRE - BP 10249  
 44158 ANCENIS CEDEX - FRANCE**

Authorized representative: **MANITOU UK**  
**Ebbleke Industrial Estate - Dorset BH 31 6BB**  
**Verwood - United Kingdom**

The manufacturer declares that the below described machinery:  
**Nom générique machine**

XXXXXXXXXXXXXX	XXXXXXXXXXXXXX
XXXXXXXXXXXXXX	XXXXXXXXXXXXXX
XXXXXXXXXXXXXX	XXXXXXXXXXXXXX
XXXXXXXXXXXXXX	XXXXXXXXXXXXXX
XXXXXXXXXXXXXX	XXXXXXXXXXXXXX
XXXXXXXXXXXXXX	XXXXXXXXXXXXXX

Complies with the following legislation:  
The supply of Machinery (Safety) Regulations 2008, as amended

The machine is designed for the lifting of persons:

Applied procedure:	Non applicable
Certificate number:	Non applicable
Dated:	
Approved body:	Non applicable

Noise Emission in the Environment by Equipment  
for use Outdoors Regulations 2001, as amended

Applied procedure:	Schedule
Approved body:	ORGANISME ADRESSE LIGNE 1 ADRESSE LIGNE 2

Sound power level:

Measured:	dB (A)
Guaranteed:	dB (A)

Electromagnetic Compatibility Regulations 2016, as amended

The following designated standards have been addressed:  
 ENXXX

The following standards or technical guidance have been addressed:  
 ENXXX

At: \_\_\_\_\_ Date: \_\_\_\_\_

Name of signatory: \_\_\_\_\_  
 Position: \_\_\_\_\_  
 Company: \_\_\_\_\_  
 Signature: \_\_\_\_\_

Figure 68: UKCA declaration of conformity - example

### 2.2.3. 55 KW ENGINE

#### 2.2.3.1 Technical datasheet MRT 1645



The specifications provided are not binding on the manufacturer and may be subject to change without prior notice.

## SPECIFICATIONS AND WEIGHTS

Table 13. Specifications and weights

Description	Unit	Values
<b>Driving speed</b>		
Maximum speed	km/h - mph	25 - 15.53
Maximum forward speed unload	km/h - mph	25 - 15.53
Maximum forward speed at nominal load	km/h - mph	5 - 3.11
Maximum reverse speed unload	km/h - mph	5 - 3.11
<b>Lifting capacity</b>		
Standard lifting height on tires with unladen forks	m - ft	15.60 - 51.18
Standard lifting height on stabs with unladen forks	m - ft	15.90 - 52.17
Lifting height at maximum capacity on tires	m - ft	9.80 - 32.15
Lifting height at maximum capacity on stabs	m - ft	8.50 - 27.89
Forward reach at maximum capacity on tires	m - ft	5 - 16.40
Forward reach at maximum capacity on stabs	m - ft	5 - 16.40
Forward reach with fork-carrier and standard forks	m - ft	13.40 - 43.96
Maximum rated capacity with standard carriage and forks on stabilizers	kg - lb	4500 - 9920.80
Distance from center of gravity	mm - in	500 - 19.68
Capacity at maximum height with standard carriage and forks on tires frontal	kg - lb	1800 - 3968.32
Capacity at maximum height with standard carriage and forks on stab	kg - lb	2500 - 5511.56
Capacity at maximum reach with standard carriage and forks on tires frontal	kg - lb	300 - 661.39
Capacity at maximum reach with standard carriage and forks on stabs	kg - lb	800 - 1763.70
<b>Standard carriage and forks</b>		
Type		PFB 1320
Fork dimensions	mm - in	1200 x 125 x 50 - 47.24 x 4.92 x 1.97
Weight distribution with standard carriage and forks		
Vehicle weight (unloaded)	kg - lb	13305 - 29332.50
<b>Ground pressure</b>		
Maximum load ground pressure on stabilizer (laden)	kg/cm <sup>2</sup>	8.23
Maximum load ground pressure on tire (unladen)	kg/cm <sup>2</sup>	-
Maximum load on each stabilizer	kg - lb	9953 - 21942.61
Maximum load on tire	kg - lb	-
<b>Stabilizers</b>		
Type		1 foxed pivot
System of control		Electrohydraulic valve
Type of control in CAB		CAN-BUS switch

<b>Description</b>	<b>Unit</b>	<b>Values</b>
<b>Gradeability</b>		
<b>Unloaded</b>	%	44.50
<b>Loaded</b>	%	44.50
<b>Boom</b>		
<b>Number of elements</b>		3
<b>Type of movement (chain, cylinder...)</b>		Cylinder 1° and chain others
<b>Drawbar pull</b>		
<b>Tractive force (Drawbarpull)</b>	daN	9417.60
<b>Break out force with bucket (according to standard ISO 8313)</b>	daN	-
<b>Hydraulic motions speeds</b>		
<b>Unladen lifting</b>	sec	25
<b>Laden lifting</b>	sec	-
<b>Unladen lowering</b>	sec	17
<b>Laden lowering</b>	sec	-
<b>Unladen extending</b>	sec	27
<b>Laden extending</b>	sec	
<b>Unladen retracting</b>	sec	19
<b>Laden retracting</b>	sec	-
<b>Reverse tilt time unladen</b>	sec	7.50
<b>Forward tilt time unladen</b>	sec	5.50
<b>Turret rotation clockwise (360°)</b>	sec	63
<b>Turret rotation counterclockwise (360°)</b>	sec	63
<b>Hydraulic circuit main-componets</b>		
<b>Locking rear axle</b>		YES
<b>Stabilizers</b>		1 cylinder for each stabilizer
<b>Low pressure valve</b>	bar - psi	270 – 3916.02
<b>Steering mode selector</b>		YES
<b>Frame levelling</b>		NO

WEIGHT AND DIMENSIONS

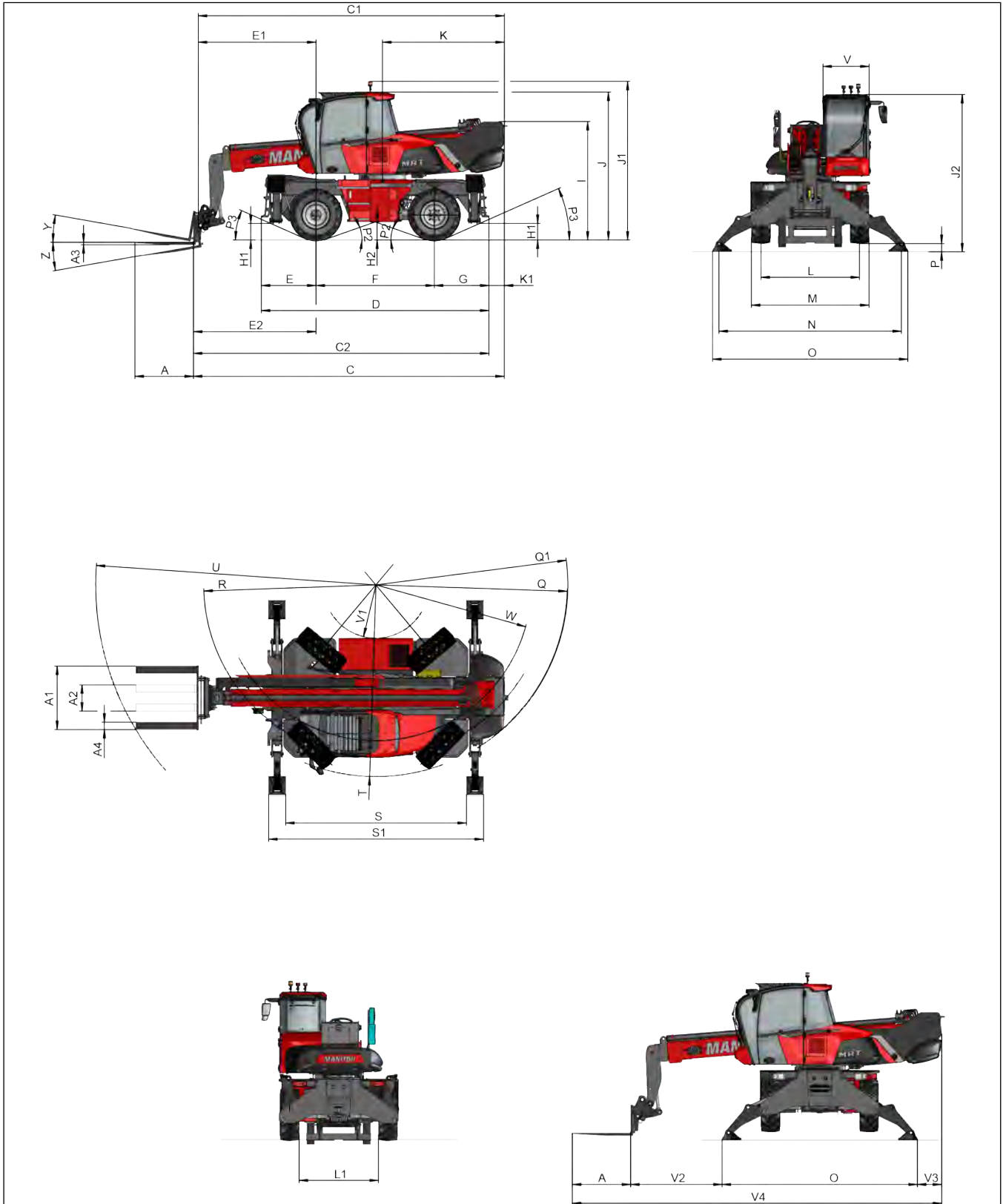


Figure 69: Dimensions (side, front and top view)

Table 14. Weight and dimensions

<b>Ref.</b>	<b>Unit</b>	<b>Values</b>	
A	m - ft	1.20	3.94
A1	m - ft	1.30	4.27
A2	m - ft	0.54	1.77
A3	m - ft	0.05	0.16
A4	m - ft	0.15	0.49
B	m - ft	-	-
C	m - ft	6.38	20.93
C1	m - ft	6.28	20.60
C2	m - ft	6.06	19.88
D	m - ft	4.67	15.32
E	m - ft	1.20	3.94
E1	m - ft	2.41	7.92
E2	m - ft	2.51	8.23
F	m - ft	2.43	7.97
G	m - ft	1.20	3.94
G1	deg.	-	-
G2	deg.	-	-
H1	m - ft	0.34	1.12
H2	m - ft	0.37	1.21
I	m - ft	2.43	7.97
J	m - ft	3.04	9.97
J1	m - ft	3.25	10.66
J2	m - ft	3.23	10.60
K	m - ft	2.50	8.20
K1	m - ft	0.32	1.05
L	m - ft	2.02	6.63
L1	m - ft	1.63	5.35
M	m - ft	2.42	7.94
N	m - ft	3.74	12.27
O	m - ft	4.01	13.16
P	m - ft	0.18	0.59
P2	deg.	19°	-
P3	deg.	24°	-
Q	m - ft	3.93	12.89
Q1	m - ft	3.94	12.93
R	m - ft	3.54	11.61
S	m - ft	3.71	12.17
S1	m - ft	4.41	14.47
T	m - ft	3.92	12.86
U	m - ft	5.75	18.86
V	m - ft	0.96	3.15
V1	m - ft	1.09	3.58
V2	m - ft	1.88	6.17
V3	m - ft	0.50	1.64
V4	m - ft	7.58	24.87
W	m - ft	3.19	10.47

<i>Ref.</i>	<i>Unit</i>	<i>Values</i>
Y	deg.	12°
Z	deg.	105°
Turret rotation	deg.	400°

## ENGINE - Deutz TCD 3.6 L4 - 55 kW ST5

Table 15. ENGINE - Deutz TCD 3.6 L4 - 55 kW ST5

<i>Description</i>	<i>Unit</i>	<i>Values</i>
Engine brand		Deutz
Engine Type	Stage / Tier	EU Stage V / US EPA Tier 4
Engine model		TCD 3.6 L4
Fuel		Diesel
Injection system		Common rail
Firing orde		1 - 3 - 4 - 2
Bore	mm - in	98 - 3.86
Stroke	mm - in	120 - 4.72
Turbocharging System		Turbocharging with charge air cooling (air/air)
Turbocharger		Single turbo
Compression ratio		-
Nominal rate	rpm	2200
Idle rate	rpm	-
Maximum idle rate	rpm	-
Rated power (ISO/TR 14396)	Hp / kW @ rpm	75/55.40 @ 2200
Maximum torque	Nm - kgf @ rpm	405 @ 1300
Number of cylinders — Displacement	- cm <sup>3</sup> / l	4 - 3620
Main Coupling type		-
Additional service PTO (type, max torque)		-
Aftertreatment type		DPF
Volt - Batteries		(24V) 2x12V
<b>Cooling system</b>		
Water cooling		YES

## ELECTRICAL CIRCUIT

Table 16. Electrical circuit

<i>Description</i>	<i>Unit</i>	<i>Values</i>
Ground		Negative
Battery standard	V-Ah	2x12V - 120Ah/850A(EN)
Battery optional	V-Ah	2x12V - 180Ah/1235A(EN)
Voltage regulator		
Starting	V/AMP	24V / 5.0kW

## ELECTRONIC DEVICES

Table 17. Electronic devices

Description	Unit	Values
Stability system		YES
Stability System Approval certification		YES
Display (IHM)		8" MTA
Joysticks		Walvoil MTH

## HYDRAULIC CIRCUIT

Table 18. Hydrostatic circuit main pump

Description	Unit	Values
Supplier	Name	CASAPPA
Pump Type	Type	MPV48.53
Displacement maximum	(cm <sup>3</sup> )/rev	53
Flow rate @ 2200 rpm	l/min	116
Max continuous pressure	bar - psi	275 – 3988.54
Max peak pressure	bar - psi	315 – 4568.69

## HYDRAULIC MAIN VALVE FOR BOOM CONTROL

Table 19. Distributor

Description	Unit	Values	
		Values A	Values B
Supplier		WALVOIL	
Type		DPX 100	
Number of section		6	
Spool control		Open Loop Stepper	
Priority steering valve		Inlet Section	
Stabilizers circuit	l/min	117	117
	bar - psi	275 ±5 - 3988.54 ±72.52	275 ±5 - 3988.54 ±72.52
Slewing circuit	l/min	117	117
	bar - psi	275 ±5 - 3988.54 ±72.52	275 ±5 - 3988.54 ±72.52
Lifting circuit	l/min	117	117
	bar - psi	275 ±5 - 3988.54 ±72.52	275 ±5 - 3988.54 ±72.52
Extension circuit	l/min	10	117
	bar - psi	230 +13/-5 - 3335,87 +188.55/-72.52	275 ±5 - 3988.54 ±72.52
Tilting circuit	l/min	10	100
	bar - psi	280 + 20/-5 - 4061.06 +290.08/-72.52	230 - 3335.87
Optional circuit	l/min	65	65
	bar - psi	250 +13/-5 - 3625.94 +188.55/-72.52	250 +13/-5 - 3625.94 +188.55/-72.52

Table 20. Steering circuits

Description	Unit	Values
Steering unit supplier		DANFOSS
Type		OSPC 200LS
Displacement	(cm <sup>3</sup> )/rev	200
Flow rate @ xxxx rpm	l/min	-
Pressure	bar - psi	180 – 2610.68 (LS Cut-off)
Steering mode valve	Supplier	REXROTH
Displacement	(cm <sup>3</sup> )/rev	-

Table 21. Brake circuit

Description	Unit	Values
Pump Type	Supplier	SAFIM
Maximum pressure	bar - psi	145 – 2103.05
Type		S6E system

## TRANSMISSION

Table 22. Gearbox

Description	Unit	Values
Type of transmission		Hydrostatic
Number of gears (forward / reverse)		(2/2)
Maximum travel speed (unladen)	km / h	25
Drawbar pull (laden)	daN	9417.60
Parking brake		Automatic with negative action
Service brake	Hydraulic	Multi-disc type in oil bath integrated in the front and rear axles
Supplier		DANA
Type		367N
Gearbox ratio — ratio		1:1.09 - 1:4.53

Table 23. Front axle

Description	Unit	Values
Supplier		DANA
Type		Steer drive rigid axel 212 Cat 2
brakes		n8 FRICTION DISKS WELLMAN N266
Parking brakes		YES
Axle ratio		

Table 24. Rear axle

Description	Unit	Values
Supplier		DANA
Type		Steer drive rigid axel 212 Cat 2
brakes		n6 FRICTION DISKS WELLMAN N266
Parking brakes		NO
Axle ratio		

## STABILIZERS

Table 25. Stabilizers

Description	Values
Type of stabilizers	Wing type
Controls	Individual or simultaneous stabilizer controls

## STANDARD FRONT & REAR TIRES

Table 26. Tires

Description	Values
Type	CAMSO
Measurement	405/70-20 14PR
Inflate pressure	5.50 bar (79.77 psi)

## OPTION FRONT & REAR TIRES

Table 27. Tires

Description	Values
Type	CEAT
Measurement	MPT602 405-70-20 165B
Inflate pressure	5.75 bar (83.4 psi)

## LIQUID CAPACITY

Table 28. Liquid capacity

Description	Unit	Values	
<b>Tanks capacities</b>			
Motor oil	l - US gal	11	2.90
Hydraulic oil tank and transmission	l - US gal	144	38.04
Fuel tank	l - US gal	130	34.34
<b>Components capacities</b>			
Engine & Cooling circuit	l - US gal	25	6.60
Gear box	l - US gal	1.60	0.42
<b>Front axle</b>			
Differential (front/rear)	l - US gal	7	1.85
Hub reducers (each)	l - US gal	2	0.53
<b>Rear axle</b>			
Differential (front/rear)	l - US gal	7.80	2.06
Hub reducers (each)	l - US gal	0.80	0.21

## NOISE AND VIBRATIONS

Table 29. Noise and vibrations

Description	Unit	Values
Acoustic pressure in the driver's cabin LpA (according to NF EN 12053)	dB (A)	68
Guaranteed noise level in the environment LwA (according to Directive 2000/14 / EC modified by Directive 2005/88 / EC)	dB (A)	104
The weighted average acceleration transmitted to the boom system/ driver's hand (according to ISO 5349-2)	m / s <sup>2</sup>	< 2.50

## MISCELLANEOUS

Table 30. Miscellaneous

Description	Values
Driving wheels (front / rear)	2 / 2
Controls	2 Joysticks
Safety cabin approval	ROPS / FOPS (Level 2)
Attachment recognition system (E-Reco)	E-Reco

### 2.2.3.2 Technical datasheet MRT 1845



The specifications provided are not binding on the manufacturer and may be subject to change without prior notice.

## SPECIFICATIONS AND WEIGHTS

Table 31. Specifications and weights

Description	Unit	Values
<b>Driving speed</b>		
Maximum speed	km/h - mph	25 - 15.53
Maximum forward speed unload	km/h - mph	25 - 15.53
Maximum forward speed at nominal load	km/h - mph	5 - 3.11
Maximum reverse speed unload	km/h - mph	5 - 3.11
<b>Lifting capacity</b>		
Standard lifting height on tires with unladen forks	m - ft	17.80 - 58.40
Standard lifting height on stabs with unladen forks	m - ft	18 - 59.05
Lifting height at maximum capacity on tires	m - ft	12.40 - 40.68
Lifting height at maximum capacity on stabs	m - ft	9.10 - 29.85
Forward reach at maximum capacity on tires	m - ft	4.50 - 14.76
Forward reach at maximum capacity on stabs	m - ft	6 - 19.68
Forward reach with fork-carrier and standard forks	m - ft	15.20 - 49.87

<i>Description</i>	<i>Unit</i>	<i>Values</i>
<b>Maximum rated capacity with standard carriage and forks on stabilizers</b>	kg - lb	4500 - 9920.80
<b>Distance from center of gravity</b>	mm - in	500 - 19.68
<b>Capacity at maximum height with standard carriage and forks on tires frontal</b>	kg - lb	1000 - 2204.62
<b>Capacity at maximum height with standard carriage and forks on stab</b>	kg - lb	2700 - 5952.48
<b>Capacity at maximum reach with standard carriage and forks on tires frontal</b>	kg - lb	300 - 661.39
<b>Capacity at maximum reach with standard carriage and forks on stabs</b>	kg - lb	600 - 1322.77
<b>Standard carriage and forks</b>		
<b>Type</b>		PFB 1320
<b>Fork dimensions</b>	mm - in	1200 x 125 x 50 - 47.24 x 4.92 x 1.97
<b>Weight distribution with standard carriage and forks</b>		
<b>Vehicle weight (unloaded)</b>	kg - lb	14100 - 31085.18
<b>Ground pressure</b>		
<b>Maximum load ground pressure on stabilizer (laden)</b>	kg/cm <sup>2</sup>	8.23
<b>Maximum load ground pressure on tire (unladen)</b>	kg/cm <sup>2</sup>	-
<b>Maximum load on each stabilizer</b>	kg - lb	9953 - 21942.61
<b>Maximum load on tire</b>	kg - lb	-
<b>Stabilizers</b>		
<b>Type</b>		1 foxed pivot
<b>System of control</b>		Electrohydraulic valve
<b>Type of control in CAB</b>		CAN-BUS switch
<b>Gradeability</b>		
<b>Unloaded</b>	%	44.50
<b>Loaded</b>	%	44.50
<b>Boom</b>		
<b>Number of elements</b>		4
<b>Type of movement (chain, cylinder...)</b>		Cylinder 1° and chain others
<b>Drawbar pull</b>		
<b>Tractive force (Drawbarpull)</b>	daN	9417.60
<b>Break out force with bucket (according to standard ISO 8313)</b>	daN	-
<b>Hydraulic motions speeds</b>		
<b>Unladen lifting</b>	sec	25
<b>Laden lifting</b>	sec	-
<b>Unladen lowering</b>	sec	17
<b>Laden lowering</b>	sec	-

<b>Description</b>	<b>Unit</b>	<b>Values</b>
<b>Unladen extending</b>	sec	32
<b>Laden extending</b>	sec	
<b>Unladen retracting</b>	sec	20
<b>Laden retracting</b>	sec	-
<b>Reverse tilt time unladen</b>	sec	7.50
<b>Forward tilt time unladen</b>	sec	5.50
<b>Turret rotation clockwise (360°)</b>	sec	63
<b>Turret rotation counterclockwise (360°)</b>	sec	63
<b>Hydraulic circuit main-componets</b>		
<b>Locking rear axle</b>		YES
<b>Stabilizers</b>		1 cylinder for each stabilizer
<b>Low pressure valve</b>	bar - psi	270 – 3916.02
<b>Steering mode selector</b>		YES
<b>Frame levelling</b>		NO

**WEIGHT AND DIMENSIONS**

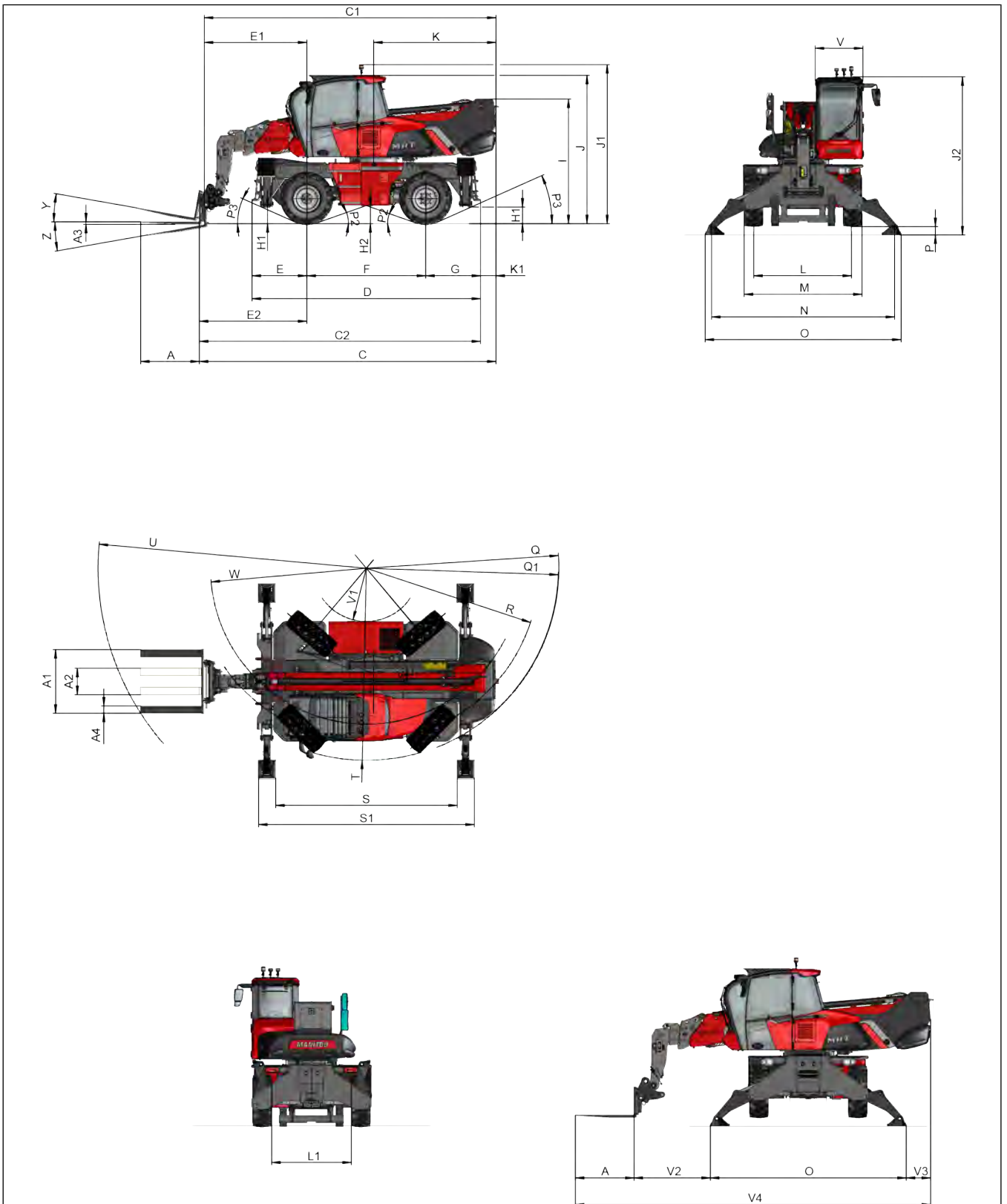


Figure 70: Dimensions (side, front and top view)

Table 32. Weight and dimensions

<b>Ref.</b>	<b>Unit</b>	<b>Values</b>	
A	m - ft	1.20	3.94
A1	m - ft	1.30	4.27
A2	m - ft	0.54	1.77
A3	m - ft	0.05	0.16
A4	m - ft	0.15	0.49
B	m - ft	-	-
C	m - ft	6.06	19.88
C1	m - ft	5.96	19.55
C2	m - ft	5.75	18.86
D	m - ft	4.67	15.32
E	m - ft	1.12	3.67
E1	m - ft	2.10	6.89
E2	m - ft	2.20	7.22
F	m - ft	2.43	7.97
G	m - ft	1.12	3.67
G1	deg.	-	-
G2	deg.	-	-
H1	m - ft	0.34	1.12
H2	m - ft	0.37	1.21
I	m - ft	2.55	8.37
J	m - ft	3.04	9.97
J1	m - ft	3.25	10.66
J2	m - ft	3.23	10.60
K	m - ft	2.50	8.20
K1	m - ft	0.32	1.05
L	m - ft	2	6.56
L1	m - ft	1.63	5.35
M	m - ft	2.42	7.94
N	m - ft	3.74	12.27
O	m - ft	4.01	13.16
P	m - ft	0.18	0.59
P2	deg.	19°	-
P3	deg.	24°	-
Q	m - ft	3.94	12.93
Q1	m - ft	3.93	12.89
R	m - ft	3.54	11.61
S	m - ft	3.71	12.17
S1	m - ft	4.41	14.47
T	m - ft	3.92	12.86
U	m - ft	5.49	18.01
V	m - ft	0.96	3.15
V1	m - ft	1.09	3.58
V2	m - ft	1.56	5.12
V3	m - ft	0.49	1.61
V4	m - ft	7.26	23.82
W	m - ft	3.19	10.47

Ref.	Unit	Values
Y	deg.	10°
Z	deg.	107°
Turret rotation	deg.	400° or 360°

### ENGINE - Deutz TCD 3.6 L4 - 55 kW ST5

Table 33. ENGINE - Deutz TCD 3.6 L4 - 55 kW ST5

Description	Unit	Values
Engine brand		Deutz
Engine Type	Stage / Tier	EU Stage V / US EPA Tier 4
Engine model		TCD 3.6 L4
Fuel		Diesel
Injection system		Common rail
Firing orde		1 - 3 - 4 - 2
Bore	mm - in	98 - 3.86
Stroke	mm - in	120 - 4.72
Turbocharging System		Turbocharging with charge air cooling (air/air)
Turbocharger		Single turbo
Compression ratio		-
Nominal rate	rpm	2200
Idle rate	rpm	-
Maximum idle rate	rpm	-
Rated power (ISO/TR 14396)	Hp / kW @ rpm	75/55.40 @ 2200
Maximum torque	Nm - kgf @ rpm	405 @ 1300
Number of cylinders — Displacement	- cm <sup>3</sup> / l	4 - 3620
Main Coupling type		-
Additional service PTO (type, max torque)		-
Aftertreatment type		DPF
Volt - Batteries		(24V) 2x12V
<b>Cooling system</b>		
Water cooling		YES

### ELECTRICAL CIRCUIT

Table 34. Electrical circuit

Description	Unit	Values
Ground		Negative
Battery standard	V-Ah	2x12V - 120Ah/850A(EN)
Battery optional	V-Ah	2x12V - 180Ah/1235A(EN)
Voltage regulator		
Starting	V/AMP	24V / 5.0kW

## ELECTRONIC DEVICES

Table 35. Electronic devices

Description	Unit	Values
Stability system		YES
Stability System Approval certification		YES
Display (IHM)		8" MTA
Joysticks		Walvoil MTH

## HYDRAULIC CIRCUIT

Table 36. Hydrostatic circuit main pump

Description	Unit	Values
Supplier	Name	CASAPPA
Pump Type	Type	MPV48.53
Displacement maximum	(cm <sup>3</sup> )/rev	53
Flow rate @ 2200 rpm	l/min	116
Max continuous pressure	bar - psi	275 – 3988.54
Max peak pressure	bar - psi	315 – 4568.69

## HYDRAULIC MAIN VALVE FOR BOOM CONTROL

Table 37. Distributor

Description	Unit	Values	
		Values A	Values B
Supplier		WALVOIL	
Type		DPX 100	
Number of section		6	
Spool control		Open Loop Stepper	
Priority steering valve		Inlet Section	
Stabilizers circuit	l/min	117	117
	bar - psi	275 ±5 - 3988.54 ±72.52	275 ±5 - 3988.54 ±72.52
Slewing circuit	l/min	117	117
	bar - psi	275 ±5 - 3988.54 ±72.52	275 ±5 - 3988.54 ±72.52
Lifting circuit	l/min	117	117
	bar - psi	275 ±5 - 3988.54 ±72.52	275 ±5 - 3988.54 ±72.52
Extension circuit	l/min	10	117
	bar - psi	230 +13/-5 - 3335,87 +188.55/-72.52	275 ±5 - 3988.54 ±72.52
Tilting circuit	l/min	10	100
	bar - psi	280 + 20/-5 - 4061.06 +290.08/-72.52	230 - 3335.87
Optional circuit	l/min	65	65
	bar - psi	250 +13/-5 - 3625.94 +188.55/-72.52	250 +13/-5 - 3625.94 +188.55/-72.52

## TRANSMISSION

Table 38. Gearbox

Description	Unit	Values
Type of transmission		Hydrostatic
Number of gears (forward / reverse)		(2/2)
Maximum travel speed (unladen)	km / h	25
Drawbar pull (laden)	daN	9417.60
Parking brake		Automatic with negative action
Service brake	Hydraulic	Multi-disc type in oil bath integrated in the front and rear axles
Supplier		DANA
Type		367N
Gearbox ratio — ratio		1:1.09 - 1:4.53

Table 39. Front axle

Description	Unit	Values
Supplier		DANA
Type		Steer drive rigid axel 212 Cat 2
brakes		n8 FRICTION DISKS WELLMAN N266
Parking brakes		YES
Axle ratio		

Table 40. Rear axle

Description	Unit	Values
Supplier		DANA
Type		Steer drive rigid axel 212 Cat 2
brakes		n6 FRICTION DISKS WELLMAN N266
Parking brakes		NO
Axle ratio		

## STABILIZERS

Table 41. Stabilizers

Description	Values
Type of stabilizers	Wing type
Controls	Individual or simultaneous stabilizer controls

## STANDARD FRONT & REAR TIRES

Table 42. Tires

Description	Values
Type	CAMSO
Measurement	405/70-20 14PR
Inflate pressure	5.50 bar (79.77 psi)

## OPTION FRONT & REAR TIRES


## LIQUID CAPACITY

Table 43. Liquid capacity

Description	Unit	Values	
<b>Tanks capacities</b>			
Motor oil	l - US gal	11	2.90
Hydraulic oil tank and transmission	l - US gal	144	38.04
Fuel tank	l - US gal	130	34.34
<b>Components capacities</b>			
Engine & Cooling circuit	l - US gal	25	6.60
Gear box	l - US gal	1.60	0.42
<b>Front axle</b>			
Differential (front/rear)	l - US gal	7	1.85
Hub reducers (each)	l - US gal	2	0.53
<b>Rear axle</b>			
Differential (front/rear)	l - US gal	7.80	2.06
Hub reducers (each)	l - US gal	0.80	0.21

## NOISE AND VIBRATIONS

Table 44. Noise and vibrations

Description	Unit	Values
Acoustic pressure in the driver's cabin LpA (according to NF EN 12053)	dB (A)	68
Guaranteed noise level in the environment LwA (according to Directive 2000/14 / EC modified by Directive 2005/88 / EC)	dB (A)	104
The weighted average acceleration transmitted to the boom system/ driver's hand (according to ISO 5349-2)	m / s <sup>2</sup>	< 2.50

## MISCELLANEOUS

Table 45. Miscellaneous

Description	Values
Driving wheels (front / rear)	2 / 2
Controls	2 Joysticks
Safety cabin approval	ROPS / FOPS (Level 2)
Attachment recognition system (E-Reco)	E-Reco

### 2.2.4. 85 KW ENGINE

#### 2.2.4.1 Technical datasheet MRT 1645



The specifications provided are not binding on the manufacturer and may be subject to change without prior notice.

## SPECIFICATIONS AND WEIGHTS

Table 46. Specifications and weights

Description	Unit	Values
<b>Driving speed</b>		
Maximum speed	km/h - mph	40 - 24.85
Maximum forward speed unload	km/h - mph	40 - 24.85
Maximum forward speed at nominal load	km/h - mph	5 - 3.11
Maximum reverse speed unload	km/h - mph	5 - 3.11
<b>Lifting capacity</b>		
Standard lifting height on tires with unladen forks	m - ft	15.60 - 51.18
Standard lifting height on stabs with unladen forks	m - ft	15.90 - 52.17
Lifting height at maximum capacity on tires	m - ft	9.80 - 32.15
Lifting height at maximum capacity on stabs	m - ft	8.50 - 27.89
Forward reach at maximum capacity on tires	m - ft	5 - 16.40
Forward reach at maximum capacity on stabs	m - ft	5 - 16.40
Forward reach with fork-carrier and standard forks	m - ft	13.40 - 43.96
Maximum rated capacity with standard carriage and forks on stabilizers	kg - lb	4500 - 9920.80
Distance from center of gravity	mm - in	500 - 19.68
Capacity at maximum height with standard carriage and forks on tires frontal	kg - lb	1800 - 3968.32
Capacity at maximum height with standard carriage and forks on stab	kg - lb	2500 - 5511.56
Capacity at maximum reach with standard carriage and forks on tires frontal	kg - lb	300 - 661.39
Capacity at maximum reach with standard carriage and forks on stabs	kg - lb	800 - 1763.70
<b>Standard carriage and forks</b>		
Type		PFB 1320
Fork dimensions	mm - in	1200 x 125 x 50 - 47.24 x 4.92 x 1.97
<b>Weight distribution with standard carriage and forks</b>		
Vehicle weight (unloaded)	kg - lb	13305 - 29332.50
<b>Ground pressure</b>		
Maximum load ground pressure on stabilizer (laden)	kg/cm <sup>2</sup>	8.23
Maximum load ground pressure on tire (unladen)	kg/cm <sup>2</sup>	-
Maximum load on each stabilizer	kg - lb	9953 - 21942.61
Maximum load on tire	kg - lb	-
<b>Stabilizers</b>		
Type		1 foxed pivot
System of control		Electrohydraulic valve
Type of control in CAB		CAN-BUS switch
<b>Gradeability</b>		
Unloaded	%	46.63
Loaded	%	50.95
<b>Boom</b>		

<i>Description</i>	<i>Unit</i>	<i>Values</i>
<b>Number of elements</b>		3
<b>Type of movement (chain, cylinder...)</b>		Cylinder 1° and chain others
<b>Drawbar pull</b>		
<b>Tractive force (Drawbarpull)</b>	daN	9711.90
<b>Break out force with bucket (according to standard ISO 8313)</b>	daN	-
<b>Hydraulic motions speeds</b>		
<b>Unladen lifting</b>	sec	25
<b>Laden lifting</b>	sec	-
<b>Unladen lowering</b>	sec	17
<b>Laden lowering</b>	sec	-
<b>Unladen extending</b>	sec	27
<b>Laden extending</b>	sec	
<b>Unladen retracting</b>	sec	19
<b>Laden retracting</b>	sec	-
<b>Reverse tilt time unladen</b>	sec	7.50
<b>Forward tilt time unladen</b>	sec	5.50
<b>Turret rotation clockwise (360°)</b>	sec	63
<b>Turret rotation counterclockwise (360°)</b>	sec	63
<b>Hydraulic circuit main-componets</b>		
<b>Locking rear axle</b>		YES
<b>Stabilizers</b>		1 cylinder for each stabilizer
<b>Low pressure valve</b>	bar - psi	270 – 3916.02
<b>Steering mode selector</b>		YES
<b>Frame levelling</b>		NO

WEIGHT AND DIMENSIONS

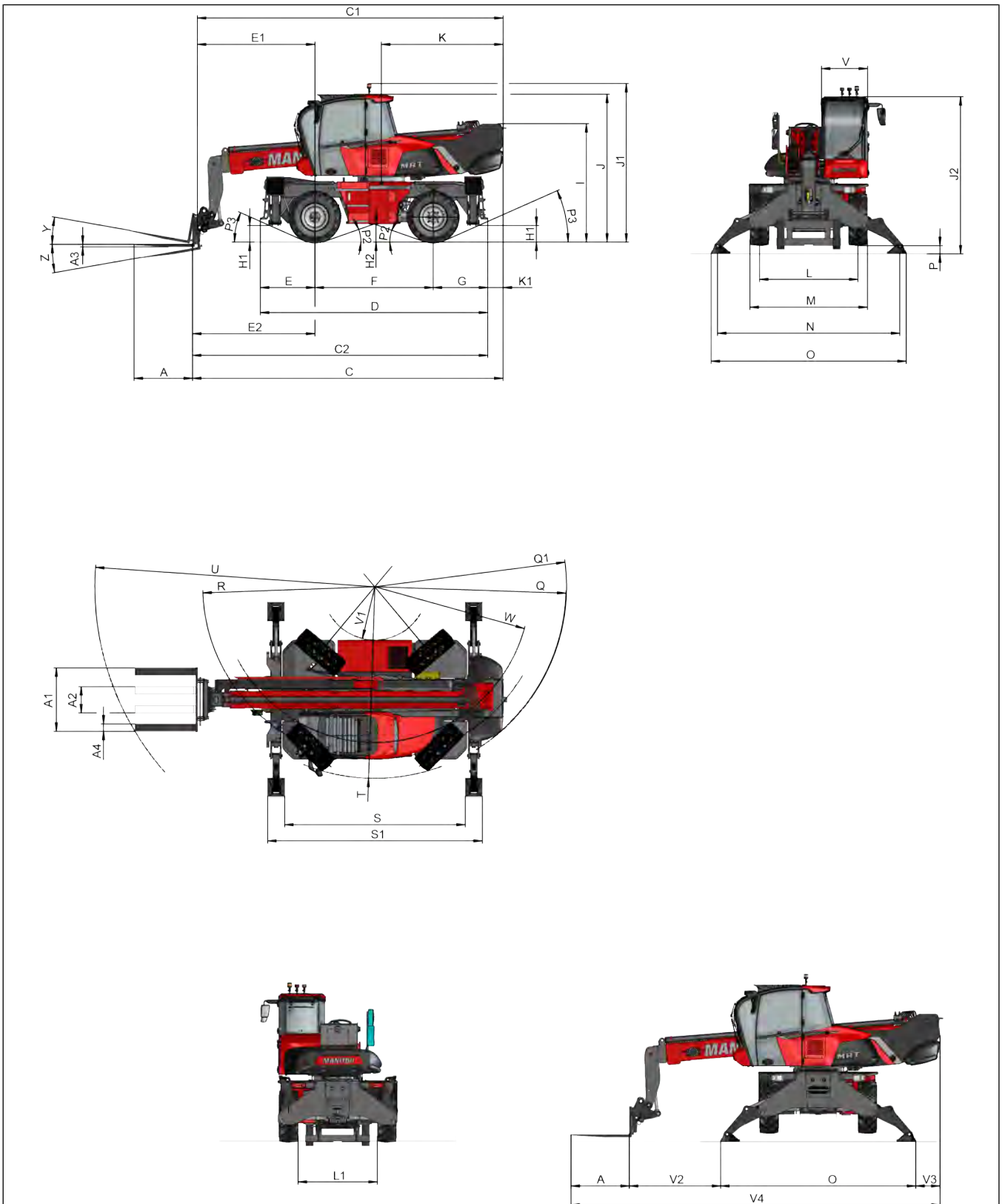


Figure 71: Dimensions (side, front and top view)

Table 47. Weight and dimensions

<b>Ref.</b>	<b>Unit</b>	<b>Values</b>	
A	m - ft	1.20	3.94
A1	m - ft	1.30	4.27
A2	m - ft	0.54	1.77
A3	m - ft	0.05	0.16
A4	m - ft	0.15	0.49
B	m - ft	-	-
C	m - ft	6.38	20.93
C1	m - ft	6.28	20.60
C2	m - ft	6.06	19.88
D	m - ft	4.67	15.32
E	m - ft	1.20	3.94
E1	m - ft	2.41	7.92
E2	m - ft	2.51	8.23
F	m - ft	2.43	7.97
G	m - ft	1.20	3.94
G1	deg.	-	-
G2	deg.	-	-
H1	m - ft	0.34	1.12
H2	m - ft	0.37	1.21
I	m - ft	2.43	7.97
J	m - ft	3.04	9.97
J1	m - ft	3.25	10.66
J2	m - ft	3.23	10.60
K	m - ft	2.50	8.20
K1	m - ft	0.32	1.05
L	m - ft	2.02	6.63
L1	m - ft	1.63	5.35
M	m - ft	2.42	7.94
N	m - ft	3.74	12.27
O	m - ft	4.01	13.16
P	m - ft	0.18	0.59
P2	deg.	19°	-
P3	deg.	24°	-
Q	m - ft	3.93	12.89
Q1	m - ft	3.94	12.93
R	m - ft	3.54	11.61
S	m - ft	3.71	12.17
S1	m - ft	4.41	14.47
T	m - ft	3.92	12.86
U	m - ft	5.75	18.86
V	m - ft	0.96	3.15
V1	m - ft	1.09	3.58
V2	m - ft	1.88	6.17
V3	m - ft	0.50	1.64
V4	m - ft	7.58	24.87
W	m - ft	3.19	10.47

Ref.	Unit	Values
Y	deg.	12°
Z	deg.	105°
Turret rotation	deg.	400°

### ENGINE - Deutz TCD 3.6 L4 - 85 kW ST5

Table 48. ENGINE - Deutz TCD 3.6 L4 - 85 kW ST5

Description	Unit	Values
Engine brand		Deutz
Engine Type	Stage / Tier	EU Stage V / US EPA Tier 4
Engine model		TCD 3.6 L4
Fuel		Diesel
Injection system		Common rail
Firing orde		1 - 3 - 4 - 2
Bore	mm	98 - 3.86
Stroke	mm	120 - 4.72
Turbocharging System		Turbocharging with charge air cooling (air/air)
Turbocharger		Single turbo
Compression ratio		-
Nominal rate	rpm	2200
Idle rate	rpm	-
Maximum idle rate	rpm	-
Rated power (ISO/TR 14396)	Hp / kW @ rpm	116/85 @ 2200
Maximum torque	Nm - kgf @ rpm	460 @ 1600
Number of cylinders — Displacement	- cm <sup>3</sup> / l	4 - 3620
Main Coupling type		-
Additional service PTO (type, max torque)		-
Aftertreatment type		DPF + SCR
Volt - Batteries		(24V) 2x12V
<b>Cooling system</b>		
Water cooling		YES

### ELECTRICAL CIRCUIT

Table 49. Electrical circuit

Description	Unit	Values
Ground		Negative
Battery standard	V-Ah	2x12V - 120Ah/850A(EN)
Battery optional	V-Ah	2x12V - 180Ah/1235A(EN)
Voltage regulator		
Starting	V/AMP	24V / 5.0kW

## ELECTRONIC DEVICES

Table 50. Electronic devices

Description	Unit	Values
Stability system		YES
Stability System Approval certification		YES
Display (IHM)		8" MTA
Joysticks		Walvoil MTH

## HYDRAULIC CIRCUIT

Table 51. Hydrostatic circuit main pump

Description	Unit	Values
Supplier	Name	CASAPPA
Pump Type	Type	MPV48.53
Displacement maximum	(cm <sup>3</sup> )/rev	53
Flow rate @ 2200 rpm	l/min	116
Max continuous pressure	bar - psi	275 – 3988.54
Max peak pressure	bar - psi	315 – 4568.69

## HYDRAULIC MAIN VALVE FOR BOOM CONTROL

Table 52. Distributor

Description	Unit	Values	
		Values A	Values B
Supplier		WALVOIL	
Type		DPX 100	
Number of section		6	
Spool control		Open Loop Stepper	
Priority steering valve		Inlet Section	
Stabilizers circuit	l/min	117	117
	bar - psi	275 ±5 - 3988.54 ±72.52	275 ±5 - 3988.54 ±72.52
Slewing circuit	l/min	117	117
	bar - psi	275 ±5 - 3988.54 ±72.52	275 ±5 - 3988.54 ±72.52
Lifting circuit	l/min	117	117
	bar - psi	275 ±5 - 3988.54 ±72.52	275 ±5 - 3988.54 ±72.52
Extension circuit	l/min	10	117
	bar - psi	230 +13/-5 - 3335,87 +188.55/-72.52	275 ±5 - 3988.54 ±72.52
Tilting circuit	l/min	10	100
	bar - psi	280 + 20/-5 - 4061.06 +290.08/-72.52	230 - 3335.87
Optional circuit	l/min	65	65
	bar - psi	250 +13/-5 - 3625.94 +188.55/-72.52	250 +13/-5 - 3625.94 +188.55/-72.52

## TRANSMISSION

Table 53. Gearbox

Description	Unit	Values
Type of transmission		Hydrostatic
Number of gears (forward / reverse)		(2/2)
Maximum travel speed (unladen)	km / h	40
Drawbar pull (laden)	daN	9711.90
Parking brake		Automatic with negative action
Service brake	Hydraulic	Multi-disc type in oil bath integrated in the front and rear axles
Supplier		DANA
Type		367N
Gearbox ratio — ratio		1:1.09 - 1:4.53

Table 54. Front axle

Description	Unit	Values
Supplier		DANA
Type		Steer drive rigid axel 212 Cat 2
brakes		n8 FRICTION DISKS WELLMAN N266
Parking brakes		YES
Axle ratio		

Table 55. Rear axle

Description	Unit	Values
Supplier		DANA
Type		Steer drive rigid axel 212 Cat 2
brakes		n6 FRICTION DISKS WELLMAN N266
Parking brakes		NO
Axle ratio		

## STABILIZERS

Table 56. Stabilizers

Description	Values
Type of stabilizers	Wing type
Controls	Individual or simultaneous stabilizer controls

## STANDARD FRONT & REAR TIRES

Table 57. Tires

Description	Values
Type	CAMSO
Measurement	405/70-20 14PR
Inflate pressure	5.50 bar (79.77 psi)

## OPTION FRONT & REAR TIRES

Table 58. Tires

Description	Values
Type	CEAT
Measurement	MPT602 405-70-20 165B
Inflate pressure	5.75 bar (83.4 psi)

## LIQUID CAPACITY

Table 59. Liquid capacity

Description	Unit	Values	
<b>Tanks capacities</b>			
Motor oil	l - US gal	11	2.90
Hydraulic oil tank and transmission	l - US gal	144	38.04
Fuel tank	l - US gal	130	34.34
DEF (Diesel Emission Fluid) Tank	l - US gal	11	2.90
<b>Components capacities</b>			
Engine & Cooling circuit	l - US gal	25	6.60
Gear box	l - US gal	1.60	0.42
<b>Front axle</b>			
Differential (front/rear)	l - US gal	7	1.85
Hub reducers (each)	l - US gal	2	0.53
<b>Rear axle</b>			
Differential (front/rear)	l - US gal	7.80	2.06
Hub reducers (each)	l - US gal	0.80	0.21

## NOISE AND VIBRATIONS

Table 60. Noise and vibrations


Description	Unit	Values
Acoustic pressure in the driver's cabin LpA (according to NF EN 12053)	dB (A)	68
Guaranteed noise level in the environment LwA (according to Directive 2000/14 / EC modified by Directive 2005/88 / EC)	dB (A)	106
The weighted average acceleration transmitted to the boom system/ driver's hand (according to ISO 5349-2)	m / s <sup>2</sup>	< 2.50

## MISCELLANEOUS

Table 61. Miscellaneous

Description	Values
Driving wheels (front / rear)	2 / 2
Controls	2 Joysticks
Safety cabin approval	ROPS / FOPS (Level 2)
Attachment recognition system (E-Reco)	E-Reco

### 2.2.4.2 Technical datasheet MRT-X 1645

 The specifications provided are not binding on the manufacturer and may be subject to change without prior notice.

## SPECIFICATIONS AND WEIGHTS

Table 62. Specifications and weights

Description	Unit	Values
<b>Driving speed</b>		
Maximum speed	km/h - mph	40 - 24.85
Maximum forward speed unload	km/h - mph	40 - 24.85
Maximum forward speed at nominal load	km/h - mph	5 - 3.11
Maximum reverse speed unload	km/h - mph	5 - 3.11
<b>Lifting capacity</b>		
Standard lifting height on tires with unladen forks	m - ft	15.60 - 51.18
Standard lifting height on stabs with unladen forks	m - ft	15.90 - 52.17
Lifting height at maximum capacity on tires	m - ft	9.80 - 32.15
Lifting height at maximum capacity on stabs	m - ft	8.50 - 27.89
Forward reach at maximum capacity on tires	m - ft	5 - 16.40
Forward reach at maximum capacity on stabs	m - ft	5 - 16.40
Forward reach with fork-carrier and standard forks	m - ft	13.40 - 43.96
Maximum rated capacity with standard carriage and forks on stabilizers	kg - lb	4500 - 9920.80
Distance from center of gravity	mm - in	500 - 19.68
Capacity at maximum height with standard carriage and forks on tires frontal	kg - lb	1800 - 3968.32
Capacity at maximum height with standard carriage and forks on stab	kg - lb	2500 - 5511.56
Capacity at maximum reach with standard carriage and forks on tires frontal	kg - lb	300 - 661.39
Capacity at maximum reach with standard carriage and forks on stabs	kg - lb	800 - 1763.70
<b>Standard carriage and forks</b>		
Type		PFB 1320
Fork dimensions	mm - in	1200 x 125 x 50 - 47.24 x 4.92 x 1.97
<b>Weight distribution with standard carriage and forks</b>		
Vehicle weight (unloaded)	kg - lb	13305 - 29332.50
<b>Ground pressure</b>		
Maximum load ground pressure on stabilizer (laden)	kg/cm <sup>2</sup>	8.23
Maximum load ground pressure on tire (unladen)	kg/cm <sup>2</sup>	-
Maximum load on each stabilizer	kg - lb	9953 - 21942.61
Maximum load on tire	kg - lb	-
<b>Stabilizers</b>		
Type		1 foxed pivot
System of control		Electrohydraulic valve
Type of control in CAB		CAN-BUS switch

<b>Description</b>	<b>Unit</b>	<b>Values</b>
<b>Gradeability</b>		
<b>Unloaded</b>	%	46.63
<b>Loaded</b>	%	50.95
<b>Boom</b>		
<b>Number of elements</b>		3
<b>Type of movement (chain, cylinder...)</b>		Cylinder 1° and chain others
<b>Drawbar pull</b>		
<b>Tractive force (Drawbarpull)</b>	daN	9711.90
<b>Break out force with bucket (according to standard ISO 8313)</b>	daN	-
<b>Hydraulic motions speeds</b>		
<b>Unladen lifting</b>	sec	25
<b>Laden lifting</b>	sec	-
<b>Unladen lowering</b>	sec	17
<b>Laden lowering</b>	sec	-
<b>Unladen extending</b>	sec	27
<b>Laden extending</b>	sec	
<b>Unladen retracting</b>	sec	19
<b>Laden retracting</b>	sec	-
<b>Reverse tilt time unladen</b>	sec	7.50
<b>Forward tilt time unladen</b>	sec	5.50
<b>Turret rotation clockwise (360°)</b>	sec	63
<b>Turret rotation counterclockwise (360°)</b>	sec	63
<b>Hydraulic circuit main-componets</b>		
<b>Locking rear axle</b>		YES
<b>Stabilizers</b>		1 cylinder for each stabilizer
<b>Low pressure valve</b>	bar - psi	270 – 3916.02
<b>Steering mode selector</b>		YES
<b>Frame levelling</b>		NO

WEIGHT AND DIMENSIONS

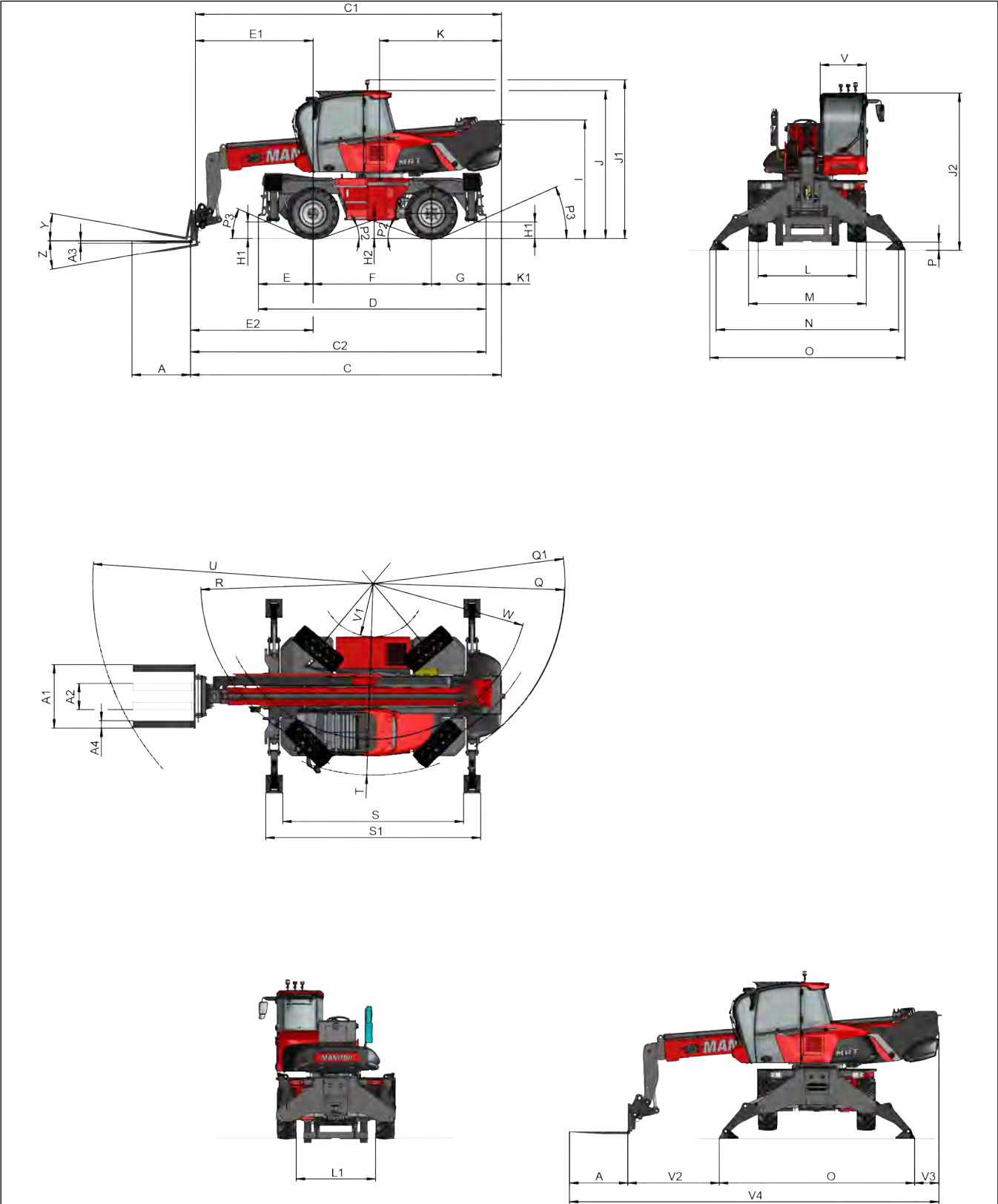


Figure 72: Dimensions (side, front and top view)

Table 63. Weight and dimensions

<b>Ref.</b>	<b>Unit</b>	<b>Values</b>	
A	m - ft	1.20	3.94
A1	m - ft	1.30	4.27
A2	m - ft	0.54	1.77
A3	m - ft	0.05	0.16
A4	m - ft	0.15	0.49
B	m - ft	-	-
C	m - ft	6.38	20.93
C1	m - ft	6.28	20.60
C2	m - ft	6.06	19.88
D	m - ft	4.67	15.32
E	m - ft	1.20	3.94
E1	m - ft	2.41	7.92
E2	m - ft	2.51	8.23
F	m - ft	2.43	7.97
G	m - ft	1.20	3.94
G1	deg.	-	-
G2	deg.	-	-
H1	m - ft	0.34	1.12
H2	m - ft	0.37	1.21
I	m - ft	2.43	7.97
J	m - ft	3.04	9.97
J1	m - ft	3.25	10.66
J2	m - ft	3.23	10.60
K	m - ft	2.50	8.20
K1	m - ft	0.32	1.05
L	m - ft	2.02	6.63
L1	m - ft	1.63	5.35
M	m - ft	2.42	7.94
N	m - ft	3.74	12.27
O	m - ft	4.01	13.16
P	m - ft	0.18	0.59
P2	deg.	19°	-
P3	deg.	24°	-
Q	m - ft	3.93	12.89
Q1	m - ft	3.94	12.93
R	m - ft	3.54	11.61
S	m - ft	3.71	12.17
S1	m - ft	4.41	14.47
T	m - ft	3.92	12.86
U	m - ft	5.75	18.86
V	m - ft	0.96	3.15
V1	m - ft	1.09	3.58
V2	m - ft	1.88	6.17
V3	m - ft	0.50	1.64
V4	m - ft	7.58	24.87
W	m - ft	3.19	10.47

Ref.	Unit	Values
Y	deg.	12°
Z	deg.	105°
Turret rotation	deg.	400°

### ENGINE - Deutz TCD3.6 EDG - 85 kW ST3A

Table 64. ENGINE - Deutz TCD3.6 EDG - 85 kW ST3A

Description	Unit	Values
Engine brand		Deutz
Engine Type	Stage / Tier	Stage 3A
Engine model		TCD3.6 EDG
Fuel		Diesel
Injection system		Common rail
Firing orde		1 - 3 - 4 - 2
Bore	mm	98 - 3.86
Stroke	mm	120 - 4.72
Turbocharging System		Turbocharging with charge air cooling (air/air)
Turbocharger		Single turbo
Compression ratio		-
Nominal rate	rpm	2200
Idle rate	rpm	-
Maximum idle rate	rpm	-
Rated power (ISO/TR 14396)	Hp / kW @ rpm	116/85 @ 2200
Maximum torque	Nm - kgf @ rpm	460 @ 1600
Number of cylinders — Displacement	- cm <sup>3</sup> / l	4 - 3620
Main Coupling type		-
Additional service PTO (type, max torque)		-
Aftertreatment type		NO
Volt - Batteries		(24V) 2x12V
<b>Cooling system</b>		
Water cooling		YES

### ELECTRICAL CIRCUIT

Table 65. Electrical circuit

Description	Unit	Values
Ground		Negative
Battery standard	V-Ah	2x12V - 120Ah/850A(EN)
Battery optional	V-Ah	2x12V - 180Ah/1235A(EN)
Voltage regulator		
Starting	V/AMP	24V / 5.0kW

## ELECTRONIC DEVICES

Table 66. Electronic devices

Description	Unit	Values
Stability system		YES
Stability System Approval certification		YES
Display (IHM)		8" MTA
Joysticks		Walvoil MTH

## HYDRAULIC CIRCUIT

Table 67. Hydrostatic circuit main pump

Description	Unit	Values
Supplier	Name	CASAPPA
Pump Type	Type	MPV48.53
Displacement maximum	(cm <sup>3</sup> )/rev	53
Flow rate @ 2200 rpm	l/min	116
Max continuous pressure	bar - psi	275 – 3988.54
Max peak pressure	bar - psi	315 – 4568.69

## HYDRAULIC MAIN VALVE FOR BOOM CONTROL

Table 68. Distributor

Description	Unit	Values	
		Values A	Values B
Supplier		WALVOIL	
Type		DPX 100	
Number of section		6	
Spool control		Open Loop Stepper	
Priority steering valve		Inlet Section	
Stabilizers circuit	l/min	117	117
	bar - psi	275 ±5 - 3988.54 ±72.52	275 ±5 - 3988.54 ±72.52
Slewing circuit	l/min	117	117
	bar - psi	275 ±5 - 3988.54 ±72.52	275 ±5 - 3988.54 ±72.52
Lifting circuit	l/min	117	117
	bar - psi	275 ±5 - 3988.54 ±72.52	275 ±5 - 3988.54 ±72.52
Extension circuit	l/min	10	117
	bar - psi	230 +13/-5 - 3335,87 +188.55/-72.52	275 ±5 - 3988.54 ±72.52
Tilting circuit	l/min	10	100
	bar - psi	280 + 20/-5 - 4061.06 +290.08/-72.52	230 - 3335.87
Optional circuit	l/min	65	65
	bar - psi	250 +13/-5 - 3625.94 +188.55/-72.52	250 +13/-5 - 3625.94 +188.55/-72.52

## TRANSMISSION

Table 69. Gearbox

Description	Unit	Values
Type of transmission		Hydrostatic
Number of gears (forward / reverse)		(2/2)
Maximum travel speed (unladen)	km / h	40
Drawbar pull (laden)	daN	9711.90
Parking brake		Automatic with negative action
Service brake	Hydraulic	Multi-disc type in oil bath integrated in the front and rear axles
Supplier		DANA
Type		367N
Gearbox ratio — ratio		1:1.09 - 1:4.53

Table 70. Front axle

Description	Unit	Values
Supplier		DANA
Type		Steer drive rigid axel 212 Cat 2
brakes		n8 FRICTION DISKS WELLMAN N266
Parking brakes		YES
Axle ratio		

Table 71. Rear axle

Description	Unit	Values
Supplier		DANA
Type		Steer drive rigid axel 212 Cat 2
brakes		n6 FRICTION DISKS WELLMAN N266
Parking brakes		NO
Axle ratio		

## STABILIZERS

Table 72. Stabilizers

Description	Values
Type of stabilizers	Wing type
Controls	Individual or simultaneous stabilizer controls

## STANDARD FRONT & REAR TIRES

Table 73. Tires

Description	Values
Type	CAMSO
Measurement	405/70-20 14PR
Inflate pressure	5.50 bar (79.77 psi)

## OPTION FRONT & REAR TIRES

Table 74. Tires

Description	Values
Type	CEAT
Measurement	MPT602 405-70-20 165B
Inflate pressure	5.75 bar (83.4 psi)

## LIQUID CAPACITY

Table 75. Liquid capacity

Description	Unit	Values	
<b>Tanks capacities</b>			
Motor oil	l - US gal	11	2.90
Hydraulic oil tank and transmission	l - US gal	144	38.04
Fuel tank	l - US gal	130	34.34
<b>Components capacities</b>			
Engine & Cooling circuit	l - US gal	25	6.60
Gear box	l - US gal	1.60	0.42
<b>Front axle</b>			
Differential (front/rear)	l - US gal	7	1.85
Hub reducers (each)	l - US gal	2	0.53
<b>Rear axle</b>			
Differential (front/rear)	l - US gal	7.80	2.06
Hub reducers (each)	l - US gal	0.80	0.21

## NOISE AND VIBRATIONS

Table 76. Noise and vibrations

Description	Unit	Values
Acoustic pressure in the driver's cabin LpA (according to NF EN 12053)	dB (A)	68
Guaranteed noise level in the environment LwA (according to Directive 2000/14 / EC modified by Directive 2005/88 / EC)	dB (A)	106
The weighted average acceleration transmitted to the boom system/ driver's hand (according to ISO 5349-2)	m / s <sup>2</sup>	< 2.50

## MISCELLANEOUS

Table 77. Miscellaneous

Description	Values
Driving wheels (front / rear)	2 / 2
Controls	2 Joysticks
Safety cabin approval	ROPS / FOPS (Level 2)
Attachment recognition system (E-Reco)	E-Reco

### 2.2.4.3 Technical datasheet MRT 1845



The specifications provided are not binding on the manufacturer and may be subject to change without prior notice.

## SPECIFICATIONS AND WEIGHTS

Table 78. Specifications and weights

Description	Unit	Values
<b>Driving speed</b>		
Maximum speed	km/h - mph	40 - 24.85
Maximum forward speed unload	km/h - mph	40 - 24.85
Maximum forward speed at nominal load	km/h - mph	5 - 3.11
Maximum reverse speed unload	km/h - mph	5 - 3.11
<b>Lifting capacity</b>		
Standard lifting height on tires with unladen forks	m - ft	17.80 - 58.40
Standard lifting height on stabs with unladen forks	m - ft	18 - 59.05
Lifting height at maximum capacity on tires	m - ft	12.40 - 40.68
Lifting height at maximum capacity on stabs	m - ft	9.10 - 29.85
Forward reach at maximum capacity on tires	m - ft	4.50 - 14.76
Forward reach at maximum capacity on stabs	m - ft	6 - 19.68
Forward reach with fork-carrier and standard forks	m - ft	15.20 - 49.87
Maximum rated capacity with standard carriage and forks on stabilizers	kg - lb	4500 - 9920.80
Distance from center of gravity	mm - in	500 - 19.68
Capacity at maximum height with standard carriage and forks on tires frontal	kg - lb	1000 - 2204.62
Capacity at maximum height with standard carriage and forks on stab	kg - lb	2700 - 5952.48
Capacity at maximum reach with standard carriage and forks on tires frontal	kg - lb	300 - 661.39
Capacity at maximum reach with standard carriage and forks on stabs	kg - lb	600 - 1322.77
<b>Standard carriage and forks</b>		
Type		PFB 1320
Fork dimensions	mm - in	1200 x 125 x 50 - 47.24 x 4.92 x 1.97
<b>Weight distribution with standard carriage and forks</b>		
Vehicle weight (unloaded)	kg - lb	14100 - 31085.18
<b>Ground pressure</b>		
Maximum load ground pressure on stabilizer (laden)	kg/cm <sup>2</sup>	8.23
Maximum load ground pressure on tire (unladen)	kg/cm <sup>2</sup>	-
Maximum load on each stabilizer	kg - lb	9953 - 21942.61

<b>Description</b>	<b>Unit</b>	<b>Values</b>
<b>Maximum load on tire</b>	kg - lb	-
<b>Stabilizers</b>		
<b>Type</b>		1 foxed pivot
<b>System of control</b>		Electrohydraulic valve
<b>Type of control in CAB</b>		CAN-BUS switch
<b>Gradeability</b>		
<b>Unloaded</b>	%	46.60
<b>Loaded</b>	%	50.90
<b>Boom</b>		
<b>Number of elements</b>		4
<b>Type of movement (chain, cylinder...)</b>		Cylinder 1° and chain others
<b>Drawbar pull</b>		
<b>Tractive force (Drawbarpull)</b>	daN	9711.90
<b>Break out force with bucket (according to standard ISO 8313)</b>	daN	-
<b>Hydraulic motions speeds</b>		
<b>Unladen lifting</b>	sec	25
<b>Laden lifting</b>	sec	-
<b>Unladen lowering</b>	sec	17
<b>Laden lowering</b>	sec	-
<b>Unladen extending</b>	sec	32
<b>Laden extending</b>	sec	
<b>Unladen retracting</b>	sec	20
<b>Laden retracting</b>	sec	-
<b>Reverse tilt time unladen</b>	sec	7.50
<b>Forward tilt time unladen</b>	sec	5.50
<b>Turret rotation clockwise (360°)</b>	sec	63
<b>Turret rotation counterclockwise (360°)</b>	sec	63
<b>Hydraulic circuit main-componets</b>		
<b>Locking rear axle</b>		YES
<b>Stabilizers</b>		1 cylinder for each stabilizer
<b>Low pressure valve</b>	bar - psi	270 – 3916.02
<b>Steering mode selector</b>		YES
<b>Frame levelling</b>		NO

**WEIGHT AND DIMENSIONS**

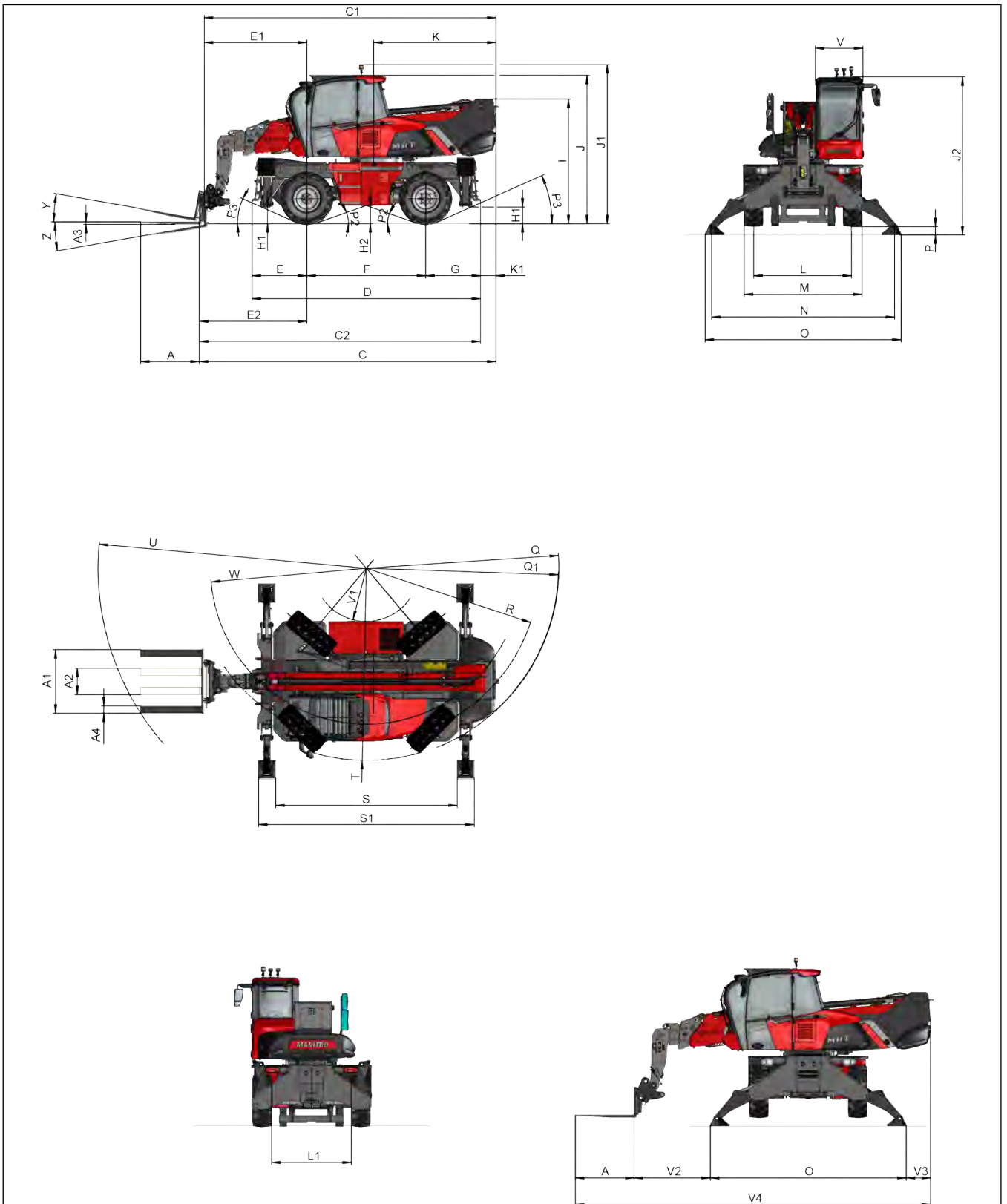


Figure 73: Dimensions (side, front and top view)

Table 79. Weight and dimensions

<b>Ref.</b>	<b>Unit</b>	<b>Values</b>	
A	m - ft	1.20	3.94
A1	m - ft	1.30	4.27
A2	m - ft	0.54	1.77
A3	m - ft	0.05	0.16
A4	m - ft	0.15	0.49
B	m - ft	-	-
C	m - ft	6.06	19.88
C1	m - ft	5.96	19.55
C2	m - ft	5.75	18.86
D	m - ft	4.67	15.32
E	m - ft	1.12	3.67
E1	m - ft	2.10	6.89
E2	m - ft	2.20	7.22
F	m - ft	2.43	7.97
G	m - ft	1.12	3.67
G1	deg.	-	-
G2	deg.	-	-
H1	m - ft	0.34	1.12
H2	m - ft	0.37	1.21
I	m - ft	2.55	8.37
J	m - ft	3.04	9.97
J1	m - ft	3.25	10.66
J2	m - ft	3.23	10.60
K	m - ft	2.50	8.20
K1	m - ft	0.32	1.05
L	m - ft	2	6.56
L1	m - ft	1.63	5.35
M	m - ft	2.42	7.94
N	m - ft	3.74	12.27
O	m - ft	4.01	13.16
P	m - ft	0.18	0.59
P2	deg.	19°	-
P3	deg.	24°	-
Q	m - ft	3.94	12.93
Q1	m - ft	3.93	12.89
R	m - ft	3.54	11.61
S	m - ft	3.71	12.17
S1	m - ft	4.41	14.47
T	m - ft	3.92	12.86
U	m - ft	5.49	18.01
V	m - ft	0.96	3.15
V1	m - ft	1.09	3.58
V2	m - ft	1.56	5.12
V3	m - ft	0.49	1.61
V4	m - ft	7.26	23.82
W	m - ft	3.19	10.47

Ref.	Unit	Values
Y	deg.	10°
Z	deg.	107°
Turret rotation	deg.	400° or 360°

### ENGINE - Deutz TCD 3.6 L4 - 85 kW ST5

Table 80. ENGINE - Deutz TCD 3.6 L4 - 85 kW ST5

Description	Unit	Values
Engine brand		Deutz
Engine Type	Stage / Tier	EU Stage V / US EPA Tier 4
Engine model		TCD 3.6 L4
Fuel		Diesel
Injection system		Common rail
Firing orde		1 - 3 - 4 - 2
Bore	mm	98 - 3.86
Stroke	mm	120 - 4.72
Turbocharging System		Turbocharging with charge air cooling (air/air)
Turbocharger		Single turbo
Compression ratio		-
Nominal rate	rpm	2200
Idle rate	rpm	-
Maximum idle rate	rpm	-
Rated power (ISO/TR 14396)	Hp / kW @ rpm	116/85 @ 2200
Maximum torque	Nm - kgf @ rpm	460 @ 1600
Number of cylinders — Displacement	- cm <sup>3</sup> / l	4 - 3620
Main Coupling type		-
Additional service PTO (type, max torque)		-
Aftertreatment type		DPF + SCR
Volt - Batteries		(24V) 2x12V
<b>Cooling system</b>		
Water cooling		YES

### ELECTRICAL CIRCUIT

Table 81. Electrical circuit

Description	Unit	Values
Ground		Negative
Battery standard	V-Ah	2x12V - 120Ah/850A(EN)
Battery optional	V-Ah	2x12V - 180Ah/1235A(EN)
Voltage regulator		
Starting	V/AMP	24V / 5.0kW

## ELECTRONIC DEVICES

Table 82. Electronic devices

Description	Unit	Values
Stability system		YES
Stability System Approval certification		YES
Display (IHM)		8" MTA
Joysticks		Walvoil MTH

## HYDRAULIC CIRCUIT

Table 83. Hydrostatic circuit main pump

Description	Unit	Values
Supplier	Name	CASAPPA
Pump Type	Type	MPV48.53
Displacement maximum	(cm <sup>3</sup> )/rev	53
Flow rate @ 2200 rpm	l/min	116
Max continuous pressure	bar - psi	275 – 3988.54
Max peak pressure	bar - psi	315 – 4568.69

## HYDRAULIC MAIN VALVE FOR BOOM CONTROL

Table 84. Distributor

Description	Unit	Values	
		Values A	Values B
Supplier		WALVOIL	
Type		DPX 100	
Number of section		6	
Spool control		Open Loop Stepper	
Priority steering valve		Inlet Section	
Stabilizers circuit	l/min	117	117
	bar - psi	275 ±5 - 3988.54 ±72.52	275 ±5 - 3988.54 ±72.52
Slewing circuit	l/min	117	117
	bar - psi	275 ±5 - 3988.54 ±72.52	275 ±5 - 3988.54 ±72.52
Lifting circuit	l/min	117	117
	bar - psi	275 ±5 - 3988.54 ±72.52	275 ±5 - 3988.54 ±72.52
Extension circuit	l/min	10	117
	bar - psi	230 +13/-5 - 3335,87 +188.55/-72.52	275 ±5 - 3988.54 ±72.52
Tilting circuit	l/min	10	100
	bar - psi	280 + 20/-5 - 4061.06 +290.08/-72.52	230 - 3335.87
Optional circuit	l/min	65	65
	bar - psi	250 +13/-5 - 3625.94 +188.55/-72.52	250 +13/-5 - 3625.94 +188.55/-72.52

## TRANSMISSION

Table 85. Gearbox

Description	Unit	Values
Type of transmission		Hydrostatic
Number of gears (forward / reverse)		(2/2)
Maximum travel speed (unladen)	km / h	40
Drawbar pull (laden)	daN	9711.90
Parking brake		Automatic with negative action
Service brake	Hydraulic	Multi-disc type in oil bath integrated in the front and rear axles
Supplier		DANA
Type		367N
Gearbox ratio — ratio		1:1.09 - 1:4.53

Table 86. Front axle

Description	Unit	Values
Supplier		DANA
Type		Steer drive rigid axel 212 Cat 2
brakes		n8 FRICTION DISKS WELLMAN N266
Parking brakes		YES
Axle ratio		

Table 87. Rear axle

Description	Unit	Values
Supplier		DANA
Type		Steer drive rigid axel 212 Cat 2
brakes		n6 FRICTION DISKS WELLMAN N266
Parking brakes		NO
Axle ratio		

## STABILIZERS

Table 88. Stabilizers

Description	Values
Type of stabilizers	Wing type
Controls	Individual or simultaneous stabilizer controls

## STANDARD FRONT & REAR TIRES

Table 89. Tires

Description	Values
Type	CAMSO
Measurement	405/70-20 14PR
Inflate pressure	5.50 bar (79.77 psi)

## OPTION FRONT & REAR TIRES

Table 90. Tires

Description	Values
Type	CEAT
Measurement	MPT602 405-70-20 165B
Inflate pressure	5.75 bar (83.4 psi)

## LIQUID CAPACITY

Table 91. Liquid capacity

Description	Unit	Values	
<b>Tanks capacities</b>			
Motor oil	l - US gal	11	2.90
Hydraulic oil tank and transmission	l - US gal	144	38.04
Fuel tank	l - US gal	130	34.34
DEF (Diesel Emission Fluid) Tank	l - US gal	11	2.90
<b>Components capacities</b>			
Engine & Cooling circuit	l - US gal	25	6.60
Gear box	l - US gal	1.60	0.42
<b>Front axle</b>			
Differential (front/rear)	l - US gal	7	1.85
Hub reducers (each)	l - US gal	2	0.53
<b>Rear axle</b>			
Differential (front/rear)	l - US gal	7.80	2.06
Hub reducers (each)	l - US gal	0.80	0.21

## NOISE AND VIBRATIONS

Table 92. Noise and vibrations


Description	Unit	Values
Acoustic pressure in the driver's cabin LpA (according to NF EN 12053)	dB (A)	68
Guaranteed noise level in the environment LwA (according to Directive 2000/14 / EC modified by Directive 2005/88 / EC)	dB (A)	104
The weighted average acceleration transmitted to the boom system/ driver's hand (according to ISO 5349-2)	m / s <sup>2</sup>	< 2.50

## MISCELLANEOUS

Table 93. Miscellaneous

Description	Values
Driving wheels (front / rear)	2 / 2
Controls	2 Joysticks
Safety cabin approval	ROPS / FOPS (Level 2)
Attachment recognition system (E-Reco)	E-Reco

### 2.2.4.4 Technical datasheet MRT-X 1845

 The specifications provided are not binding on the manufacturer and may be subject to change without prior notice.

## SPECIFICATIONS AND WEIGHTS

Table 94. Specifications and weights

Description	Unit	Values
<b>Driving speed</b>		
Maximum speed	km/h - mph	40 - 24.85
Maximum forward speed unload	km/h - mph	40 - 24.85
Maximum forward speed at nominal load	km/h - mph	5 - 3.11
Maximum reverse speed unload	km/h - mph	5 - 3.11
<b>Lifting capacity</b>		
Standard lifting height on tires with unladen forks	m - ft	17.80 - 58.40
Standard lifting height on stabs with unladen forks	m - ft	18 - 59.05
Lifting height at maximum capacity on tires	m - ft	12.40 - 40.68
Lifting height at maximum capacity on stabs	m - ft	9.10 - 29.85
Forward reach at maximum capacity on tires	m - ft	4.50 - 14.76
Forward reach at maximum capacity on stabs	m - ft	6 - 19.68
Forward reach with fork-carrier and standard forks	m - ft	15.20 - 49.87
Maximum rated capacity with standard carriage and forks on stabilizers	kg - lb	4500 - 9920.80
Distance from center of gravity	mm - in	500 - 19.68
Capacity at maximum height with standard carriage and forks on tires frontal	kg - lb	1000 - 2204.62
Capacity at maximum height with standard carriage and forks on stab	kg - lb	2700 - 5952.48
Capacity at maximum reach with standard carriage and forks on tires frontal	kg - lb	300 - 661.39
Capacity at maximum reach with standard carriage and forks on stabs	kg - lb	600 - 1322.77
<b>Standard carriage and forks</b>		
Type		PFB 1320
Fork dimensions	mm - in	1200 x 125 x 50 - 47.24 x 4.92 x 1.97
<b>Weight distribution with standard carriage and forks</b>		
Vehicle weight (unloaded)	kg - lb	14100 - 31085.18
<b>Ground pressure</b>		

<i>Description</i>	<i>Unit</i>	<i>Values</i>
Maximum load ground pressure on stabilizer (laden)	kg/cm <sup>2</sup>	8.23
Maximum load ground pressure on tire (unladen)	kg/cm <sup>2</sup>	-
Maximum load on each stabilizer	kg - lb	9953 - 21942.61
Maximum load on tire	kg - lb	-
<b>Stabilizers</b>		
Type		1 foxed pivot
System of control		Electrohydraulic valve
Type of control in CAB		CAN-BUS switch
<b>Gradeability</b>		
Unloaded	%	46.60
Loaded	%	50.90
<b>Boom</b>		
Number of elements		4
Type of movement (chain, cylinder...)		Cylinder 1° and chain others
<b>Drawbar pull</b>		
Tractive force (Drawbarpull)	daN	9711.90
Break out force with bucket (according to standard ISO 8313)	daN	-
<b>Hydraulic motions speeds</b>		
Unladen lifting	sec	25
Laden lifting	sec	-
Unladen lowering	sec	17
Laden lowering	sec	-
Unladen extending	sec	32
Laden extending	sec	
Unladen retracting	sec	20
Laden retracting	sec	-
Reverse tilt time unladen	sec	7.50
Forward tilt time unladen	sec	5.50
Turret rotation clockwise (360°)	sec	63
Turret rotation counterclockwise (360°)	sec	63
<b>Hydraulic circuit main-componets</b>		
Locking rear axle		YES
Stabilizers		1 cylinder for each stabilizer
Low pressure valve	bar - psi	270 – 3916.02
Steering mode selector		YES
Frame levelling		NO

**WEIGHT AND DIMENSIONS**

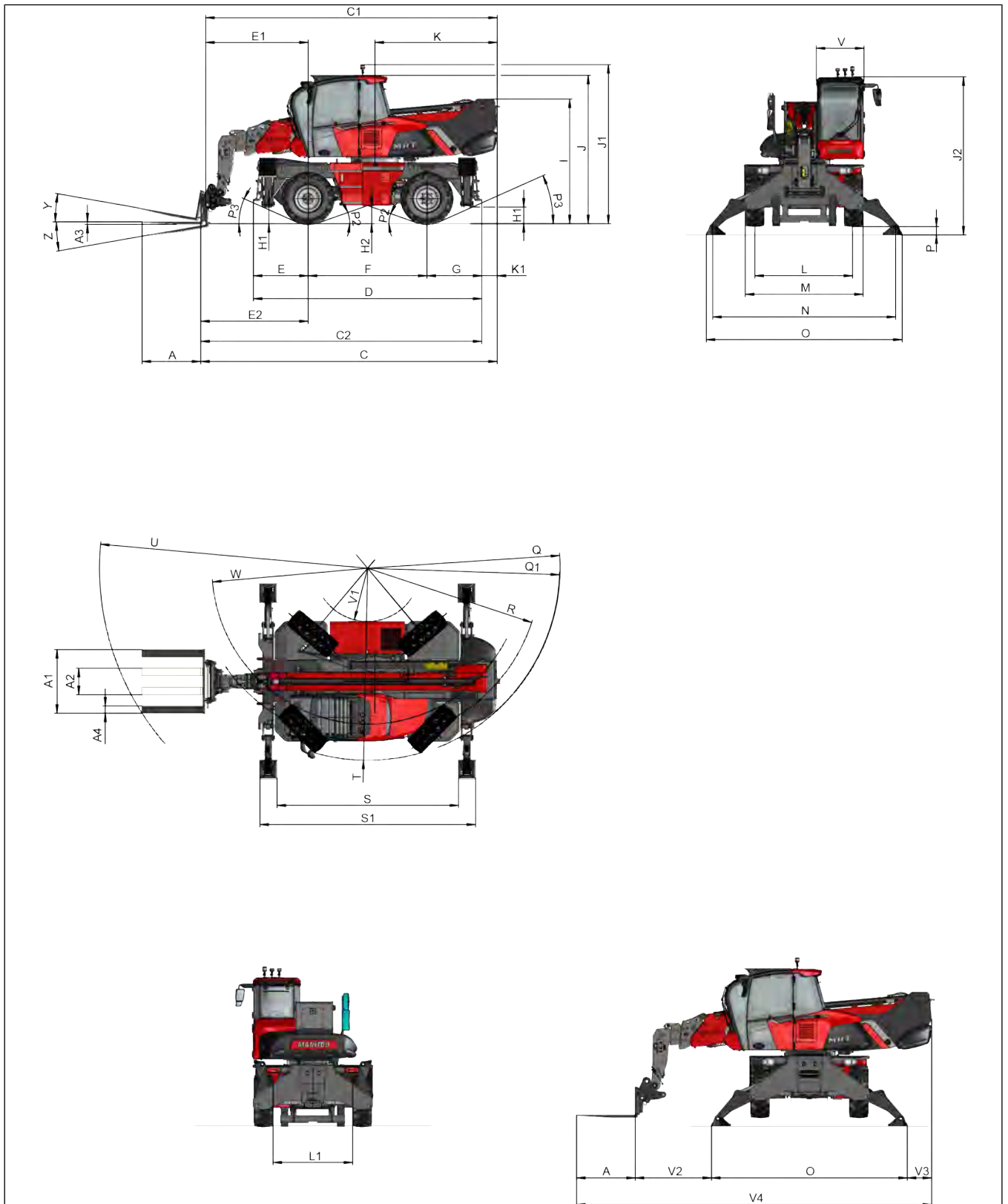


Figure 74: Dimensions (side, front and top view)

Table 95. Weight and dimensions

<b>Ref.</b>	<b>Unit</b>	<b>Values</b>	
A	m - ft	1.20	3.94
A1	m - ft	1.30	4.27
A2	m - ft	0.54	1.77
A3	m - ft	0.05	0.16
A4	m - ft	0.15	0.49
B	m - ft	-	-
C	m - ft	6.06	19.88
C1	m - ft	5.96	19.55
C2	m - ft	5.75	18.86
D	m - ft	4.67	15.32
E	m - ft	1.12	3.67
E1	m - ft	2.10	6.89
E2	m - ft	2.20	7.22
F	m - ft	2.43	7.97
G	m - ft	1.12	3.67
G1	deg.	-	-
G2	deg.	-	-
H1	m - ft	0.34	1.12
H2	m - ft	0.37	1.21
I	m - ft	2.55	8.37
J	m - ft	3.04	9.97
J1	m - ft	3.25	10.66
J2	m - ft	3.23	10.60
K	m - ft	2.50	8.20
K1	m - ft	0.32	1.05
L	m - ft	2	6.56
L1	m - ft	1.63	5.35
M	m - ft	2.42	7.94
N	m - ft	3.74	12.27
O	m - ft	4.01	13.16
P	m - ft	0.18	0.59
P2	deg.	19°	-
P3	deg.	24°	-
Q	m - ft	3.94	12.93
Q1	m - ft	3.93	12.89
R	m - ft	3.54	11.61
S	m - ft	3.71	12.17
S1	m - ft	4.41	14.47
T	m - ft	3.92	12.86
U	m - ft	5.49	18.01
V	m - ft	0.96	3.15
V1	m - ft	1.09	3.58
V2	m - ft	1.56	5.12
V3	m - ft	0.49	1.61
V4	m - ft	7.26	23.82
W	m - ft	3.19	10.47

Ref.	Unit	Values
Y	deg.	10°
Z	deg.	107°
Turret rotation	deg.	400°

### ENGINE - Deutz TCD3.6 EDG - 85 kW ST3A

Table 96. ENGINE - Deutz TCD3.6 EDG - 85 kW ST3A

Description	Unit	Values
Engine brand		Deutz
Engine Type	Stage / Tier	Stage 3A
Engine model		TCD3.6 EDG
Fuel		Diesel
Injection system		Common rail
Firing orde		1 - 3 - 4 - 2
Bore	mm	98 - 3.86
Stroke	mm	120 - 4.72
Turbocharging System		Turbocharging with charge air cooling (air/air)
Turbocharger		Single turbo
Compression ratio		-
Nominal rate	rpm	2200
Idle rate	rpm	-
Maximum idle rate	rpm	-
Rated power (ISO/TR 14396)	Hp / kW @ rpm	116/85 @ 2200
Maximum torque	Nm - kgf @ rpm	460 @ 1600
Number of cylinders — Displacement	- cm <sup>3</sup> / l	4 - 3620
Main Coupling type		-
Additional service PTO (type, max torque)		-
Aftertreatment type		NO
Volt - Batteries		(24V) 2x12V
<b>Cooling system</b>		
Water cooling		YES

### ELECTRICAL CIRCUIT

Table 97. Electrical circuit

Description	Unit	Values
Ground		Negative
Battery standard	V-Ah	2x12V - 120Ah/850A(EN)
Battery optional	V-Ah	2x12V - 180Ah/1235A(EN)
Voltage regulator		
Starting	V/AMP	24V / 5.0kW

## ELECTRONIC DEVICES

Table 98. Electronic devices

Description	Unit	Values
Stability system		YES
Stability System Approval certification		YES
Display (IHM)		8" MTA
Joysticks		Walvoil MTH

## HYDRAULIC CIRCUIT

Table 99. Hydrostatic circuit main pump

Description	Unit	Values
Supplier	Name	CASAPPA
Pump Type	Type	MPV48.53
Displacement maximum	(cm <sup>3</sup> )/rev	53
Flow rate @ 2200 rpm	l/min	116
Max continuous pressure	bar - psi	275 – 3988.54
Max peak pressure	bar - psi	315 – 4568.69

## HYDRAULIC MAIN VALVE FOR BOOM CONTROL

Table 100. Distributor

Description	Unit	Values	
		Values A	Values B
Supplier		WALVOIL	
Type		DPX 100	
Number of section		6	
Spool control		Open Loop Stepper	
Priority steering valve		Inlet Section	
Stabilizers circuit	l/min	117	117
	bar - psi	275 ±5 - 3988.54 ±72.52	275 ±5 - 3988.54 ±72.52
Slewing circuit	l/min	117	117
	bar - psi	275 ±5 - 3988.54 ±72.52	275 ±5 - 3988.54 ±72.52
Lifting circuit	l/min	117	117
	bar - psi	275 ±5 - 3988.54 ±72.52	275 ±5 - 3988.54 ±72.52
Extension circuit	l/min	10	117
	bar - psi	230 +13/-5 - 3335,87 +188.55/-72.52	275 ±5 - 3988.54 ±72.52
Tilting circuit	l/min	10	100
	bar - psi	280 + 20/-5 - 4061.06 +290.08/-72.52	230 - 3335.87
Optional circuit	l/min	65	65
	bar - psi	250 +13/-5 - 3625.94 +188.55/-72.52	250 +13/-5 - 3625.94 +188.55/-72.52

## TRANSMISSION

Table 101. Gearbox

Description	Unit	Values
Type of transmission		Hydrostatic
Number of gears (forward / reverse)		(2/2)
Maximum travel speed (unladen)	km / h	40
Drawbar pull (laden)	daN	9711.90
Parking brake		Automatic with negative action
Service brake	Hydraulic	Multi-disc type in oil bath integrated in the front and rear axles
Supplier		DANA
Type		367N
Gearbox ratio — ratio		1:1.09 - 1:4.53

Table 102. Front axle

Description	Unit	Values
Supplier		DANA
Type		Steer drive rigid axel 212 Cat 2
brakes		n8 FRICTION DISKS WELLMAN N266
Parking brakes		YES
Axle ratio		

Table 103. Rear axle

Description	Unit	Values
Supplier		DANA
Type		Steer drive rigid axel 212 Cat 2
brakes		n6 FRICTION DISKS WELLMAN N266
Parking brakes		NO
Axle ratio		

## STABILIZERS

Table 104. Stabilizers

Description	Values
Type of stabilizers	Wing type
Controls	Individual or simultaneous stabilizer controls

## STANDARD FRONT & REAR TIRES

Table 105. Tires

Description	Values
Type	CAMSO
Measurement	405/70-20 14PR
Inflate pressure	5.50 bar (79.77 psi)

## OPTION FRONT & REAR TIRES

Table 106. Tires

Description	Values
Type	CEAT
Measurement	MPT602 405-70-20 165B
Inflate pressure	5.75 bar (83.4 psi)

## LIQUID CAPACITY

Table 107. Liquid capacity

Description	Unit	Values	
<b>Tanks capacities</b>			
Motor oil	l - US gal	11	2.90
Hydraulic oil tank and transmission	l - US gal	144	38.04
Fuel tank	l - US gal	130	34.34
<b>Components capacities</b>			
Engine & Cooling circuit	l - US gal	25	6.60
Gear box	l - US gal	1.60	0.42
<b>Front axle</b>			
Differential (front/rear)	l - US gal	7	1.85
Hub reducers (each)	l - US gal	2	0.53
<b>Rear axle</b>			
Differential (front/rear)	l - US gal	7.80	2.06
Hub reducers (each)	l - US gal	0.80	0.21

## NOISE AND VIBRATIONS

Table 108. Noise and vibrations

Description	Unit	Values
Acoustic pressure in the driver's cabin LpA (according to NF EN 12053)	dB (A)	68
Guaranteed noise level in the environment LwA (according to Directive 2000/14 / EC modified by Directive 2005/88 / EC)	dB (A)	106
The weighted average acceleration transmitted to the boom system/ driver's hand (according to ISO 5349-2)	m / s <sup>2</sup>	< 2.50

## MISCELLANEOUS

Table 109. Miscellaneous

Description	Values
Driving wheels (front / rear)	2 / 2
Controls	2 Joysticks
Safety cabin approval	ROPS / FOPS (Level 2)
Attachment recognition system (E-Reco)	E-Reco

### 2.2.4.5 Technical datasheet MRT 2145



The specifications provided are not binding on the manufacturer and may be subject to change without prior notice.

## SPECIFICATIONS AND WEIGHTS

Table 110. Specifications and weights

Description	Unit	Values
<b>Driving speed</b>		
Maximum speed	km/h - mph	40 - 24.85
Maximum forward speed unload	km/h - mph	40 - 24.85
Maximum forward speed at nominal load	km/h - mph	5 - 3.11
Maximum reverse speed unload	km/h - mph	5 - 3.11
<b>Lifting capacity</b>		
Standard lifting height on tires with unladen forks	m - ft	16 - 52.49
Standard lifting height on stabs with unladen forks	m - ft	20.60 - 67.59
Lifting height at maximum capacity on tires	m - ft	9.70 - 31.82
Lifting height at maximum capacity on stabs	m - ft	11.70 - 38.38
Forward reach at maximum capacity on tires	m - ft	5 - 16.40
Forward reach at maximum capacity on stabs	m - ft	7 - 22.96
Forward reach with fork-carrier and standard forks	m - ft	18 - 59.06
Maximum rated capacity with standard carriage and forks on stabilizers	kg - lb	4500 - 9920.80
Distance from center of gravity	mm - in	500 - 19.68
Capacity at maximum height with standard carriage and forks on tires frontal	kg - lb	1500 - 3306.93
Capacity at maximum height with standard carriage and forks on stab	kg - lb	2500 - 5511.56
Capacity at maximum reach with standard carriage and forks on tires frontal	kg - lb	300 - 661.39
Capacity at maximum reach with standard carriage and forks on stabs	kg - lb	600 - 1322.77
<b>Standard carriage and forks</b>		
Type		PFB 1320
Fork dimensions	mm - in	1200 x 125 x 50 - 47.24 x 4.92 x 1.97
<b>Weight distribution with standard carriage and forks</b>		
Vehicle weight (unloaded)	kg - lb	14900 - 32848.88
<b>Ground pressure</b>		
Maximum load ground pressure on stabilizer (laden)	kg/cm <sup>2</sup>	8.22
Maximum load ground pressure on tire (unladen)	kg/cm <sup>2</sup>	-
Maximum load on each stabilizer	kg - lb	10274 - 22650.29
Maximum load on tire	kg - lb	-
<b>Stabilizers</b>		
Type		1 foxed pivot + 1 mobile pivot
System of control		Electrohydraulic valve
Type of control in CAB		CAN-BUS switch
<b>Gradeability</b>		
Unloaded	%	48.70
Loaded	%	49.80

<b>Boom</b>		
<b>Number of elements</b>		4
<b>Type of movement (chain, cylinder...)</b>		Cylinder 1° and chain others
<b>Drawbar pull</b>		
<b>Tractive force (Drawbarpull)</b>	daN	9711.90
<b>Break out force with bucket (according to standard ISO 8313)</b>	daN	-
<b>Hydraulic motions speeds</b>		
<b>Unladen lifting</b>	sec	22
<b>Laden lifting</b>	sec	-
<b>Unladen lowering</b>	sec	18.50
<b>Laden lowering</b>	sec	-
<b>Unladen extending</b>	sec	29
<b>Laden extending</b>	sec	
<b>Unladen retracting</b>	sec	20
<b>Laden retracting</b>	sec	-
<b>Reverse tilt time unladen</b>	sec	6
<b>Forward tilt time unladen</b>	sec	5
<b>Turret rotation clockwise (360°)</b>	sec	65
<b>Turret rotation counterclockwise (360°)</b>	sec	65
<b>Hydraulic circuit main-componets</b>		
<b>Locking rear axle</b>		YES
<b>Stabilizers</b>		1 cylinder for each stabilizer
<b>Low pressure valve</b>	bar - psi	270 – 3916.02
<b>Steering mode selector</b>		YES
<b>Frame levelling</b>		NO

**WEIGHT AND DIMENSIONS**

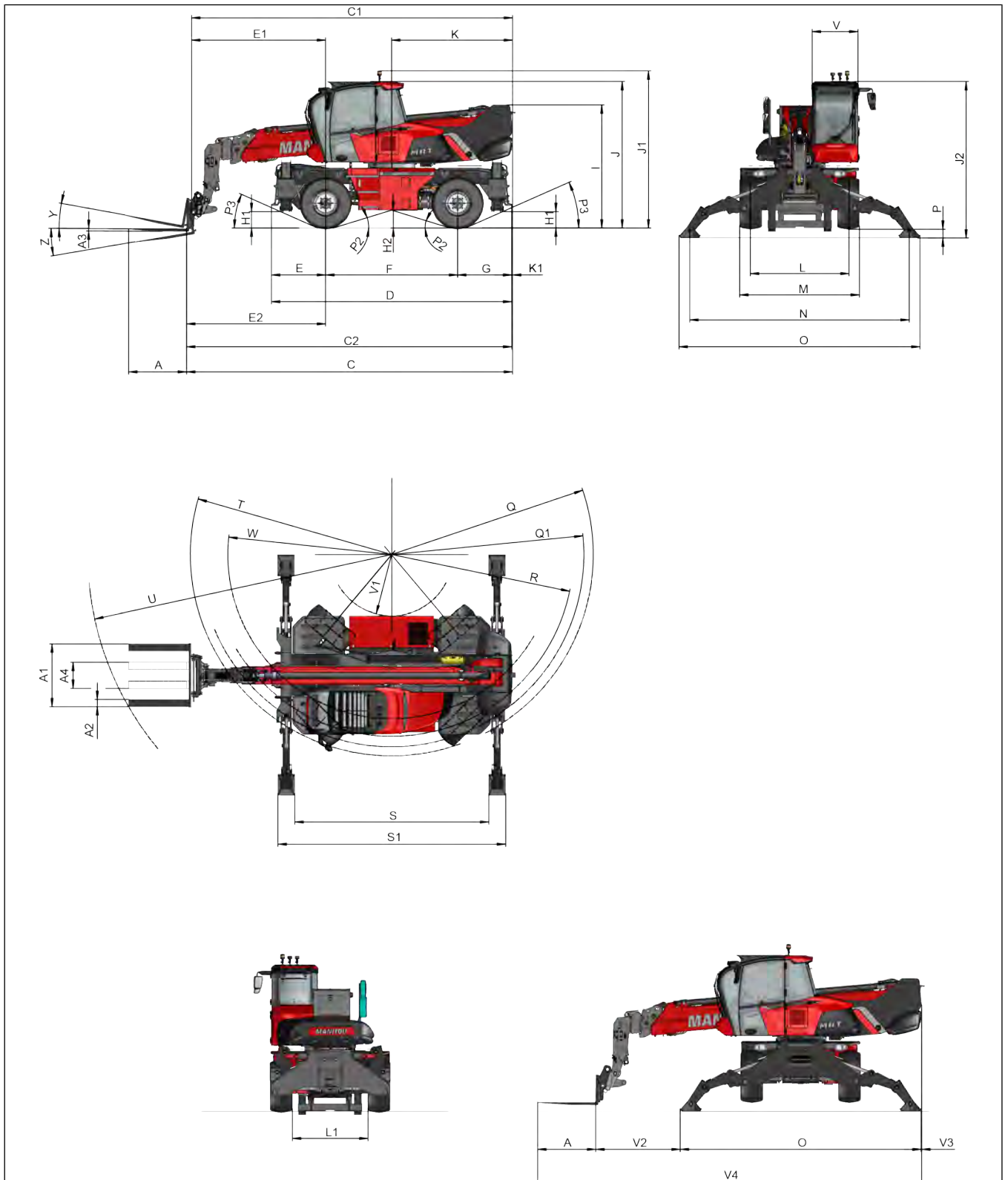


Figure 75: Dimensions (side, front and top view)

Table 111. Weight and dimensions

Ref.	Unit	Values	
A	m - ft	1.20	3.94
A1	m - ft	1.20	3.94

<b>Ref.</b>	<b>Unit</b>	<b>Values</b>	
A2	m - ft	0.15	0.49
A3	m - ft	0.05	0.16
A4	m - ft	0.54	1.77
B	m - ft	-	-
C	m - ft	6.73	22.08
C1	m - ft	6.64	21.78
C2	m - ft	6.72	22.05
D	m - ft	4.97	16.31
E	m - ft	1.12	3.67
E1	m - ft	2.77	9.09
E2	m - ft	2.87	9.42
F	m - ft	2.73	8.96
G	m - ft	1.12	3.67
G1	deg.	-	-
G2	deg.	-	-
H1	m - ft	0.34	1.12
H2	m - ft	0.37	1.21
I	m - ft	2.55	8.37
J	m - ft	3.04	9.97
J1	m - ft	3.25	10.66
J2	m - ft	3.24	10.63
K	m - ft	2.50	8.20
K1	m - ft	0.02	0.07
L	m - ft	2.04	6.69
L1	m - ft	1.56	5.12
M	m - ft	2.48	8.14
N	m - ft	4.54	14.90
O	m - ft	4.98	16.34
P	m - ft	0.18	0.59
P2	deg.	17°	-
P3	deg.	24°	-
Q	m - ft	4.17	13.68
Q1	m - ft	3.98	13.06
R	m - ft	3.76	12.34
S	m - ft	4.01	13.16
S1	m - ft	4.71	15.45
T	m - ft	4.16	13.65
U	m - ft	6.28	20.60
V	m - ft	0.96	3.15
V1	m - ft	1.28	4.20
V2	m - ft	1.75	5.74
V3	m - ft	0.01	0.03
V4	m - ft	7.93	26.02
W	m - ft	3.39	11.12
Y	deg.	10°	-

<b>Ref.</b>	<b>Unit</b>	<b>Values</b>
Z	deg.	107°
Turret rotation	deg.	400° or 360°

### ENGINE - Deutz TCD 3.6 L4 - 85 kW ST5

Table 112. ENGINE - Deutz TCD 3.6 L4 - 85 kW ST5

<b>Description</b>	<b>Unit</b>	<b>Values</b>
<b>Engine brand</b>		Deutz
<b>Engine Type</b>	Stage / Tier	EU Stage V / US EPA Tier 4
<b>Engine model</b>		TCD 3.6 L4
<b>Fuel</b>		Diesel
<b>Injection system</b>		Common rail
<b>Firing orde</b>		1 - 3 - 4 - 2
<b>Bore</b>	mm	98 - 3.86
<b>Stroke</b>	mm	120 - 4.72
<b>Turbocharging System</b>		Turbocharging with charge air cooling (air/air)
<b>Turbocharger</b>		Single turbo
<b>Compression ratio</b>		-
<b>Nominal rate</b>	rpm	2200
<b>Idle rate</b>	rpm	-
<b>Maximum idle rate</b>	rpm	-
<b>Rated power (ISO/TR 14396)</b>	Hp / kW @ rpm	116/85 @ 2200
<b>Maximum torque</b>	Nm - kgf @ rpm	460 @ 1600
<b>Number of cylinders — Displacement</b>	- cm <sup>3</sup> / l	4 - 3620
<b>Main Coupling type</b>		-
<b>Additional service PTO (type, max torque)</b>		-
<b>Aftertreatment type</b>		DPF + SCR
<b>Volt - Batteries</b>		(24V) 2x12V
<b>Cooling system</b>		
<b>Water cooling</b>		YES

### ELECTRICAL CIRCUIT

Table 113. Electrical circuit

<b>Description</b>	<b>Unit</b>	<b>Values</b>
<b>Ground</b>		Negative
<b>Battery standard</b>	V-Ah	2x12V - 120Ah/850A(EN)
<b>Battery optional</b>	V-Ah	2x12V - 180Ah/1235A(EN)
<b>Voltage regulator</b>		
<b>Starting</b>	V/AMP	24V / 5.0kW

## ELECTRONIC DEVICES

Table 114. Electronic devices

Description	Unit	Values
Stability system		YES
Stability System Approval certification		YES
Display (IHM)		8" MTA
Joysticks		Walvoil MTH

## HYDRAULIC CIRCUIT

Table 115. Hydrostatic circuit main pump

Description	Unit	Values
Supplier	Name	CASAPPA
Pump Type	Type	MPV48.53
Displacement maximum	(cm <sup>3</sup> )/rev	53
Flow rate @ 2200 rpm	l/min	116
Max continuous pressure	bar - psi	275 – 3988.54
Max peak pressure	bar - psi	315 – 4568.69

## HYDRAULIC MAIN VALVE FOR BOOM CONTROL

Table 116. Distributor

Description	Unit	Values	
		Values A	Values B
Supplier		WALVOIL	
Type		DPX 100	
Number of section		6	
Spool control		Open Loop Stepper	
Priority steering valve		Inlet Section	
Stabilizers circuit	l/min	117	117
	bar - psi	275 ±5 - 3988.54 ±72.52	275 ±5 - 3988.54 ±72.52
Slewing circuit	l/min	117	117
	bar - psi	275 ±5 - 3988.54 ±72.52	275 ±5 - 3988.54 ±72.52
Lifting circuit	l/min	117	117
	bar - psi	275 ±5 - 3988.54 ±72.52	275 ±5 - 3988.54 ±72.52
Extension circuit	l/min	10	117
	bar - psi	230 +13/-5 - 3335,87 +188.55/-72.52	275 ±5 - 3988.54 ±72.52
Tilting circuit	l/min	10	100
	bar - psi	280 + 20/-5 - 4061.06 +290.08/-72.52	230 - 3335.87
Optional circuit	l/min	65	65
	bar - psi	250 +13/-5 - 3625.94 +188.55/-72.52	250 +13/-5 - 3625.94 +188.55/-72.52

## TRANSMISSION

Table 117. Gearbox

Description	Unit	Values
Type of transmission		Hydrostatic
Number of gears (forward / reverse)		(2/2)
Maximum travel speed (unladen)	km / h	40
Drawbar pull (laden)	daN	9711.90
Parking brake		Automatic with negative action
Service brake	Hydraulic	Multi-disc type in oil bath integrated in the front and rear axles
Supplier		DANA
Type		367N
Gearbox ratio — ratio		1:1.09 - 1:4.53

Table 118. Front axle

Description	Unit	Values
Supplier		DANA
Type		Steer drive rigid axel 212 Cat 2
brakes		n8 FRICTION DISKS WELLMAN N266
Parking brakes		YES
Axle ratio		

Table 119. Rear axle

Description	Unit	Values
Supplier		DANA
Type		Steer drive rigid axel 212 Cat 2
brakes		n6 FRICTION DISKS WELLMAN N266
Parking brakes		NO
Axle ratio		

## STABILIZERS

Table 120. Stabilizers

Description	Values
Type of stabilizers	Spider type
Controls	Individual or simultaneous stabilizer controls

## STANDARD FRONT & REAR TIRES

Table 121. Tires

Description	Values
Type	ALLIANCE
Measurement	18-19.50 18 PR
Inflate pressure	7.50 bar (108.78 psi)

## OPTIONAL FRONT & REAR TIRES

Table 122. Tires

Description	Values
Type	CAMSO
Measurement	18-19.50
Inflate pressure	7.50 bar (108.78 psi)

## LIQUID CAPACITY

Description	Unit	Values	
<b>Tanks capacities</b>			
Motor oil	l - US gal	11	2.90
Hydraulic oil tank and transmission	l - US gal	150	39.62
Fuel tank	l - US gal	133	35.13
DEF (Diesel Emission Fluid) Tank	l - US gal	11	2.90
<b>Components capacities</b>			
Engine & Cooling circuit	l - US gal	25	6.60
Gear box	l - US gal	1.60	0.42
<b>Front axle</b>			
Differential (front/rear)	l - US gal	7	1.85
Hub reducers (each)	l - US gal	2	0.53
<b>Rear axle</b>			
Differential (front/rear)	l - US gal	7.80	2.06
Hub reducers (each)	l - US gal	0.80	0.21

## NOISE AND VIBRATIONS

Table 123. Noise and vibrations

Description	Unit	Values
Acoustic pressure in the driver's cabin LpA (according to NF EN 12053)	dB (A)	68
Guaranteed noise level in the environment LwA (according to Directive 2000/14 / EC modified by Directive 2005/88 / EC)	dB (A)	106
The weighted average acceleration transmitted to the boom system/ driver's hand (according to ISO 5349-2)	m / s <sup>2</sup>	< 2.50

## MISCELLANEOUS

Table 124. Miscellaneous

Description	Values
Driving wheels (front / rear)	2 / 2
Controls	2 Joysticks
Safety cabin approval	ROPS / FOPS (Level 2)
Attachment recognition system (E-Reco)	E-Reco

### 2.2.4.6 Technical datasheet MRT-X 2145



The specifications provided are not binding on the manufacturer and may be subject to change without prior notice.

## SPECIFICATIONS AND WEIGHTS

Table 125. Specifications and weights

Description	Unit	Values
<b>Driving speed</b>		
Maximum speed	km/h - mph	40 - 24.85
Maximum forward speed unload	km/h - mph	40 - 24.85
Maximum forward speed at nominal load	km/h - mph	5 - 3.11
Maximum reverse speed unload	km/h - mph	5 - 3.11
<b>Lifting capacity</b>		
Standard lifting height on tires with unladen forks	m - ft	16 - 52.49
Standard lifting height on stabs with unladen forks	m - ft	20.60 - 67.59
Lifting height at maximum capacity on tires	m - ft	9.70 - 31.82
Lifting height at maximum capacity on stabs	m - ft	11.70 - 38.38
Forward reach at maximum capacity on tires	m - ft	5 - 16.40
Forward reach at maximum capacity on stabs	m - ft	7 - 22.96
Forward reach with fork-carrier and standard forks	m - ft	18 - 59.06
Maximum rated capacity with standard carriage and forks on stabilizers	kg - lb	4500 - 9920.80
Distance from center of gravity	mm - in	500 - 19.68
Capacity at maximum height with standard carriage and forks on tires frontal	kg - lb	1500 - 3306.93
Capacity at maximum height with standard carriage and forks on stab	kg - lb	2500 - 5511.56
Capacity at maximum reach with standard carriage and forks on tires frontal	kg - lb	300 - 661.39
Capacity at maximum reach with standard carriage and forks on stabs	kg - lb	600 - 1322.77
<b>Standard carriage and forks</b>		
Type		PFB 1320
Fork dimensions	mm - in	1200 x 125 x 50 - 47.24 x 4.92 x 1.97
<b>Weight distribution with standard carriage and forks</b>		
Vehicle weight (unloaded)	kg - lb	14900 - 32848.88
<b>Ground pressure</b>		
Maximum load ground pressure on stabilizer (laden)	kg/cm <sup>2</sup>	8.22
Maximum load ground pressure on tire (unladen)	kg/cm <sup>2</sup>	-
Maximum load on each stabilizer	kg - lb	10274 - 22650.29
Maximum load on tire	kg - lb	-
<b>Stabilizers</b>		
Type		1 foxed pivot + 1 mobile pivot
System of control		Electrohydraulic valve
Type of control in CAB		CAN-BUS switch
<b>Gradeability</b>		
Unloaded	%	48.70
Loaded	%	49.80

<b>Boom</b>		
<b>Number of elements</b>		4
<b>Type of movement (chain, cylinder...)</b>		Cylinder 1° and chain others
<b>Drawbar pull</b>		
<b>Tractive force (Drawbarpull)</b>	daN	9711.90
<b>Break out force with bucket (according to standard ISO 8313)</b>	daN	-
<b>Hydraulic motions speeds</b>		
<b>Unladen lifting</b>	sec	22
<b>Laden lifting</b>	sec	-
<b>Unladen lowering</b>	sec	18.50
<b>Laden lowering</b>	sec	-
<b>Unladen extending</b>	sec	29
<b>Laden extending</b>	sec	
<b>Unladen retracting</b>	sec	20
<b>Laden retracting</b>	sec	-
<b>Reverse tilt time unladen</b>	sec	6
<b>Forward tilt time unladen</b>	sec	5
<b>Turret rotation clockwise (360°)</b>	sec	65
<b>Turret rotation counterclockwise (360°)</b>	sec	65
<b>Hydraulic circuit main-componets</b>		
<b>Locking rear axle</b>		YES
<b>Stabilizers</b>		1 cylinder for each stabilizer
<b>Low pressure valve</b>	bar - psi	270 – 3916.02
<b>Steering mode selector</b>		YES
<b>Frame levelling</b>		NO

**WEIGHT AND DIMENSIONS**

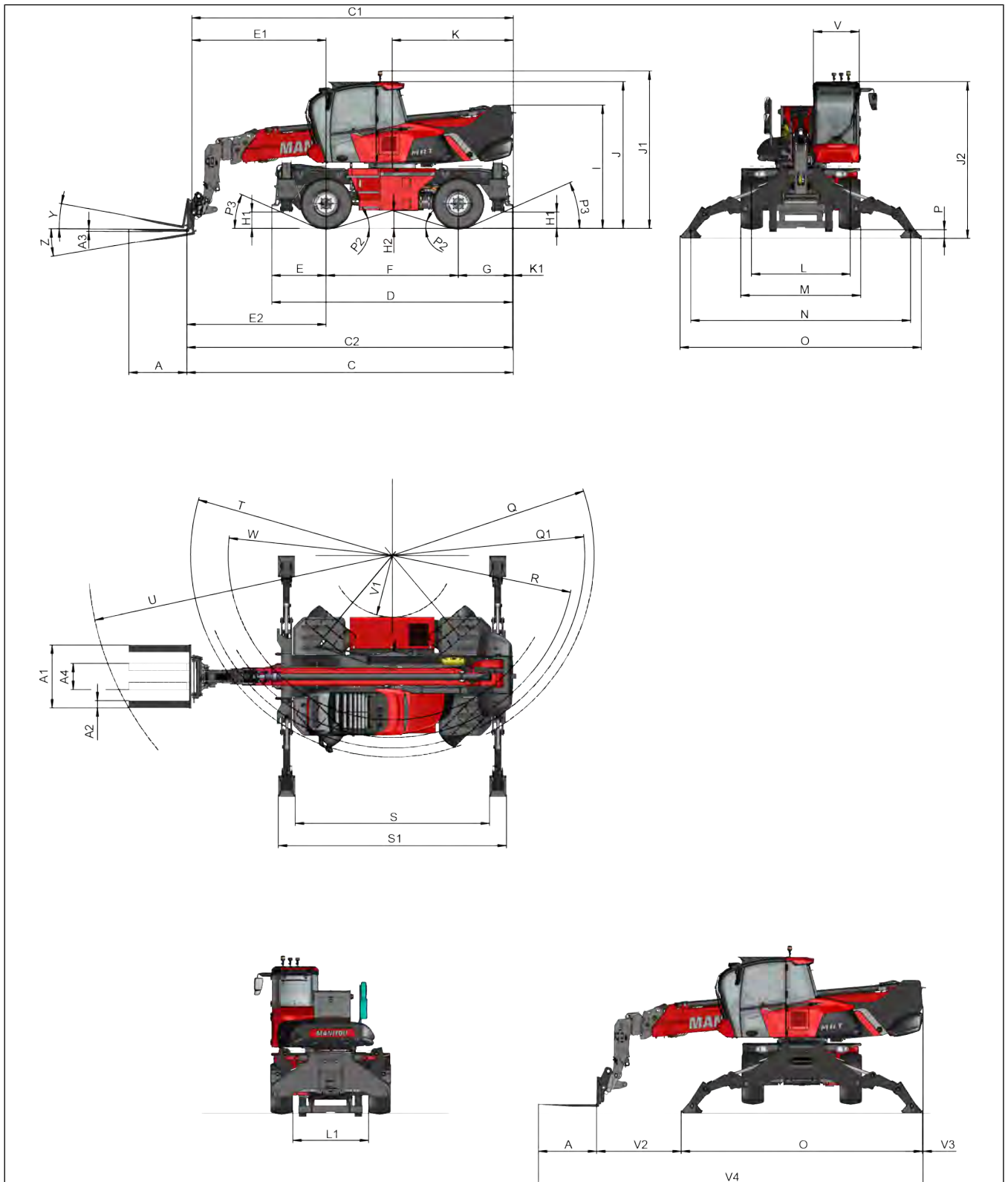


Figure 76: Dimensions (side, front and top view)

Table 126. Weight and dimensions

Ref.	Unit	Values	
A	m - ft	1.20	3.94
A1	m - ft	1.20	3.94

<i>Ref.</i>	<i>Unit</i>	<i>Values</i>	
A2	m - ft	0.15	0.49
A3	m - ft	0.05	0.16
A4	m - ft	0.54	1.77
B	m - ft	-	-
C	m - ft	6.73	22.08
C1	m - ft	6.64	21.78
C2	m - ft	6.72	22.05
D	m - ft	4.97	16.31
E	m - ft	1.12	3.67
E1	m - ft	2.77	9.09
E2	m - ft	2.87	9.42
F	m - ft	2.73	8.96
G	m - ft	1.12	3.67
G1	deg.	-	-
G2	deg.	-	-
H1	m - ft	0.34	1.12
H2	m - ft	0.37	1.21
I	m - ft	2.55	8.37
J	m - ft	3.04	9.97
J1	m - ft	3.25	10.66
J2	m - ft	3.24	10.63
K	m - ft	2.50	8.20
K1	m - ft	0.02	0.07
L	m - ft	2.04	6.69
L1	m - ft	1.56	5.12
M	m - ft	2.48	8.14
N	m - ft	4.54	14.90
O	m - ft	4.98	16.34
P	m - ft	0.18	0.59
P2	deg.	17°	-
P3	deg.	24°	-
Q	m - ft	4.17	13.68
Q1	m - ft	3.98	13.06
R	m - ft	3.76	12.34
S	m - ft	4.01	13.16
S1	m - ft	4.71	15.45
T	m - ft	4.16	13.65
U	m - ft	6.28	20.60
V	m - ft	0.96	3.15
V1	m - ft	1.28	4.20
V2	m - ft	1.75	5.74
V3	m - ft	0.01	0.03
V4	m - ft	7.93	26.02
W	m - ft	3.39	11.12
Y	deg.	10°	-

Ref.	Unit	Values
Z	deg.	107°
Turret rotation	deg.	400°

### ENGINE - Deutz TCD3.6 EDG - 85 kW ST3A

Table 127. ENGINE - Deutz TCD3.6 EDG - 85 kW ST3A

Description	Unit	Values
Engine brand		Deutz
Engine Type	Stage / Tier	Stage 3A
Engine model		TCD3.6 EDG
Fuel		Diesel
Injection system		Common rail
Firing orde		1 - 3 - 4 - 2
Bore	mm	98 - 3.86
Stroke	mm	120 - 4.72
Turbocharging System		Turbocharging with charge air cooling (air/air)
Turbocharger		Single turbo
Compression ratio		-
Nominal rate	rpm	2200
Idle rate	rpm	-
Maximum idle rate	rpm	-
Rated power (ISO/TR 14396)	Hp / kW @ rpm	116/85 @ 2200
Maximum torque	Nm - kgf @ rpm	460 @ 1600
Number of cylinders — Displacement	- cm <sup>3</sup> / l	4 - 3620
Main Coupling type		-
Additional service PTO (type, max torque)		-
Aftertreatment type		NO
Volt - Batteries		(24V) 2x12V
<b>Cooling system</b>		
Water cooling		YES

### ELECTRICAL CIRCUIT

Table 128. Electrical circuit

Description	Unit	Values
Ground		Negative
Battery standard	V-Ah	2x12V - 120Ah/850A(EN)
Battery optional	V-Ah	2x12V - 180Ah/1235A(EN)
Voltage regulator		
Starting	V/AMP	24V / 5.0kW

## ELECTRONIC DEVICES

Table 129. Electronic devices

Description	Unit	Values
Stability system		YES
Stability System Approval certification		YES
Display (IHM)		8" MTA
Joysticks		Walvoil MTH

## HYDRAULIC CIRCUIT

Table 130. Hydrostatic circuit main pump

Description	Unit	Values
Supplier	Name	CASAPPA
Pump Type	Type	MPV48.53
Displacement maximum	(cm <sup>3</sup> )/rev	53
Flow rate @ 2200 rpm	l/min	116
Max continuous pressure	bar - psi	275 – 3988.54
Max peak pressure	bar - psi	315 – 4568.69

## HYDRAULIC MAIN VALVE FOR BOOM CONTROL

Table 131. Distributor

Description	Unit	Values	
		Values A	Values B
Supplier		WALVOIL	
Type		DPX 100	
Number of section		6	
Spool control		Open Loop Stepper	
Priority steering valve		Inlet Section	
Stabilizers circuit	l/min	117	117
	bar - psi	275 ±5 - 3988.54 ±72.52	275 ±5 - 3988.54 ±72.52
Slewing circuit	l/min	117	117
	bar - psi	275 ±5 - 3988.54 ±72.52	275 ±5 - 3988.54 ±72.52
Lifting circuit	l/min	117	117
	bar - psi	275 ±5 - 3988.54 ±72.52	275 ±5 - 3988.54 ±72.52
Extension circuit	l/min	10	117
	bar - psi	230 +13/-5 - 3335,87 +188.55/-72.52	275 ±5 - 3988.54 ±72.52
Tilting circuit	l/min	10	100
	bar - psi	280 + 20/-5 - 4061.06 +290.08/-72.52	230 - 3335.87
Optional circuit	l/min	65	65
	bar - psi	250 +13/-5 - 3625.94 +188.55/-72.52	250 +13/-5 - 3625.94 +188.55/-72.52

## TRANSMISSION

Table 132. Gearbox

Description	Unit	Values
Type of transmission		Hydrostatic
Number of gears (forward / reverse)		(2/2)
Maximum travel speed (unladen)	km / h	40
Drawbar pull (laden)	daN	9711.90
Parking brake		Automatic with negative action
Service brake	Hydraulic	Multi-disc type in oil bath integrated in the front and rear axles
Supplier		DANA
Type		367N
Gearbox ratio — ratio		1:1.09 - 1:4.53

Table 133. Front axle

Description	Unit	Values
Supplier		DANA
Type		Steer drive rigid axel 212 Cat 2
brakes		n8 FRICTION DISKS WELLMAN N266
Parking brakes		YES
Axle ratio		

Table 134. Rear axle

Description	Unit	Values
Supplier		DANA
Type		Steer drive rigid axel 212 Cat 2
brakes		n6 FRICTION DISKS WELLMAN N266
Parking brakes		NO
Axle ratio		

## STABILIZERS

Table 135. Stabilizers

Description	Values
Type of stabilizers	Spider type
Controls	Individual or simultaneous stabilizer controls

## STANDARD FRONT & REAR TIRES

Table 136. Tires

Description	Values
Type	ALLIANCE
Measurement	18-19.50 18 PR
Inflate pressure	7.50 bar (108.78 psi)

## OPTIONAL FRONT & REAR TIRES

Table 137. Tires

Description	Values
Type	CAMSO
Measurement	18-19.50
Inflate pressure	7.50 bar (108.78 psi)

## LIQUID CAPACITY

Description	Unit	Values	
<b>Tanks capacities</b>			
Motor oil	l - US gal	11	2.90
Hydraulic oil tank and transmission	l - US gal	150	39.62
Fuel tank	l - US gal	133	35.13
<b>Components capacities</b>			
Engine & Cooling circuit	l - US gal	25	6.60
Gear box	l - US gal	1.60	0.42
<b>Front axle</b>			
Differential (front/rear)	l - US gal	7	1.85
Hub reducers (each)	l - US gal	2	0.53
<b>Rear axle</b>			
Differential (front/rear)	l - US gal	7.80	2.06
Hub reducers (each)	l - US gal	0.80	0.21

## NOISE AND VIBRATIONS

Table 138. Noise and vibrations

Description	Unit	Values
Acoustic pressure in the driver's cabin LpA (according to NF EN 12053)	dB (A)	68
Guaranteed noise level in the environment LwA (according to Directive 2000/14 / EC modified by Directive 2005/88 / EC)	dB (A)	104
The weighted average acceleration transmitted to the boom system/ driver's hand (according to ISO 5349-2)	m / s <sup>2</sup>	< 2.50

## MISCELLANEOUS

Table 139. Miscellaneous

Description	Values
Driving wheels (front / rear)	2 / 2
Controls	2 Joysticks
Safety cabin approval	ROPS / FOPS (Level 2)
Attachment recognition system (E-Reco)	E-Reco

### 2.2.4.7 Technical datasheet MRT 2545



The specifications provided are not binding on the manufacturer and may be subject to change without prior notice.

## SPECIFICATIONS AND WEIGHTS

Table 140. Specifications and weights

Description	Unit	Values
<b>Driving speed</b>		
Maximum speed	km/h - mph	40 - 24.85
Maximum forward speed unload	km/h - mph	40 - 24.85
Maximum forward speed at nominal load	km/h - mph	5 - 3.11
Maximum reverse speed unload	km/h - mph	5 - 3.11
<b>Lifting capacity</b>		
Standard lifting height on tires with unladen forks	m - ft	16.30 - 53.48
Standard lifting height on stabs with unladen forks	m - ft	24.60 - 80.71
Lifting height at maximum capacity on tires	m - ft	10.30 - 33.79
Lifting height at maximum capacity on stabs	m - ft	11.40 - 37.40
Forward reach at maximum capacity on tires	m - ft	5.50 - 18.04
Forward reach at maximum capacity on stabs	m - ft	6.60 - 21.65
Forward reach with fork-carrier and standard forks	m - ft	19.50 - 63.98
Maximum rated capacity with standard carriage and forks on stabilizers	kg - lb	4500 - 9920.80
Distance from center of gravity	mm - in	500 - 19.68
Capacity at maximum height with standard carriage and forks on tires frontal	kg - lb	1000 - 2204.62
Capacity at maximum height with standard carriage and forks on stab	kg - lb	2000 - 4409.25
Capacity at maximum reach with standard carriage and forks on tires frontal	kg - lb	300 - 661.39
Capacity at maximum reach with standard carriage and forks on stabs	kg - lb	300 - 661.39
<b>Standard carriage and forks</b>		
Type		PFB 1320
Fork dimensions	mm - in	1200 x 125 x 50 - 47.24 x 4.92 x 1.97
<b>Weight distribution with standard carriage and forks</b>		
Vehicle weight (unloaded)	kg - lb	15910 - 35075.55
<b>Ground pressure</b>		
Maximum load ground pressure on stabilizer (laden)	kg/cm <sup>2</sup>	8.81
Maximum load ground pressure on tire (unladen)	kg/cm <sup>2</sup>	-
Maximum load on each stabilizer	kg - lb	11005 - 24261.87
Maximum load on tire	kg - lb	-
<b>Stabilizers</b>		
Type		1 foxed pivot + 1 mobile pivot
System of control		Electrohydraulic valve
Type of control in CAB		CAN-BUS switch
<b>Gradeability</b>		
Unloaded	%	48.70
Loaded	%	49.80

<b>Boom</b>		
<b>Number of elements</b>		4
<b>Type of movement (chain, cylinder...)</b>		Cylinder 1° and chain others
<b>Drawbar pull</b>		
<b>Tractive force (Drawbarpull)</b>	daN	9711.90
<b>Break out force with bucket (according to standard ISO 8313)</b>	daN	-
<b>Hydraulic motions speeds</b>		
<b>Unladen lifting</b>	sec	27
<b>Laden lifting</b>	sec	-
<b>Unladen lowering</b>	sec	18.50
<b>Laden lowering</b>	sec	-
<b>Unladen extending</b>	sec	35
<b>Laden extending</b>	sec	
<b>Unladen retracting</b>	sec	30
<b>Laden retracting</b>	sec	-
<b>Reverse tilt time unladen</b>	sec	6
<b>Forward tilt time unladen</b>	sec	5
<b>Turret rotation clockwise (360°)</b>	sec	90
<b>Turret rotation counterclockwise (360°)</b>	sec	90
<b>Hydraulic circuit main-componets</b>		
<b>Locking rear axle</b>		YES
<b>Stabilizers</b>		1 cylinder for each stabilizer
<b>Low pressure valve</b>	bar - psi	270 – 3916.02
<b>Steering mode selector</b>		YES
<b>Frame levelling</b>		NO

WEIGHT AND DIMENSIONS

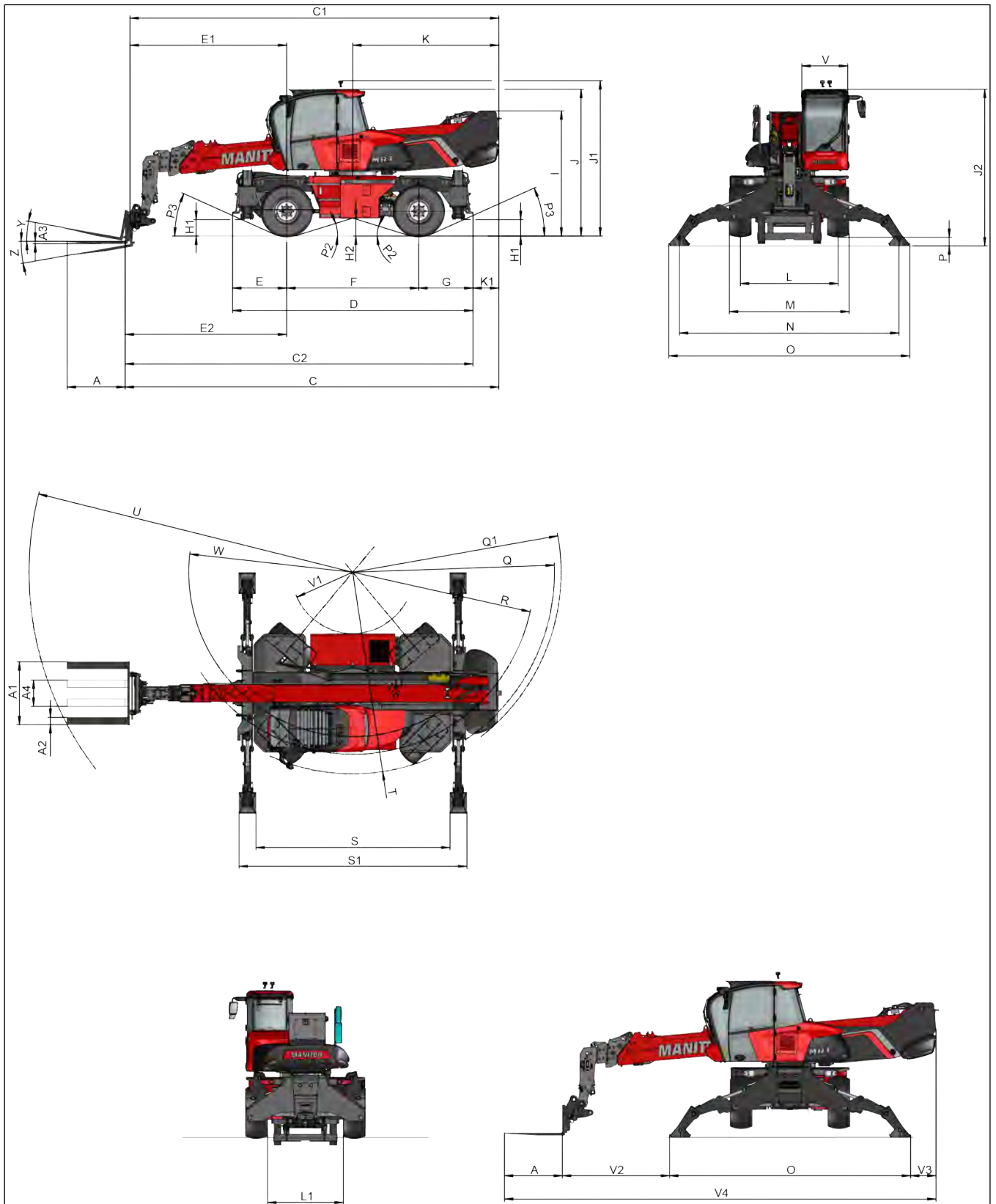


Figure 77: Dimensions (side, front and top view)

Table 141. Weight and dimensions

<b>Ref.</b>	<b>Unit</b>	<b>Values</b>	
A	m - ft	1.20	3.94
A1	m - ft	1.30	4.27
A2	m - ft	0.15	0.49
A3	m - ft	0.05	0.16
A4	m - ft	0.54	1.77
B	m - ft	-	-
C	m - ft	7.72	25.33
C1	m - ft	7.62	25
C2	m - ft	7.19	23.59
D	m - ft	4.97	16.31
E	m - ft	1.12	3.67
E1	m - ft	3.24	10.63
E2	m - ft	3.34	10.96
F	m - ft	2.73	8.96
G	m - ft	1.12	3.67
G1	deg.	-	-
G2	deg.	-	-
H1	m - ft	0.34	1.12
H2	m - ft	0.37	1.21
I	m - ft	2.59	8.50
J	m - ft	3.04	9.97
J1	m - ft	3.21	10.53
J2	m - ft	3.24	10.63
K	m - ft	3.02	9.91
K1	m - ft	0.53	1.74
L	m - ft	2.02	6.63
L1	m - ft	1.56	5.12
M	m - ft	2.48	8.14
N	m - ft	4.54	14.90
O	m - ft	4.98	16.34
P	m - ft	0.18	0.59
P2	deg.	17°	-
P3	deg.	24°	-
Q	m - ft	4.17	13.68
Q1	m - ft	4.31	14.14
R	m - ft	3.76	12.34
S	m - ft	4.01	13.16
S1	m - ft	4.71	15.45
T	m - ft	4.16	13.65
U	m - ft	6.69	21.95
V	m - ft	0.96	3.15
V1	m - ft	1.26	4.13
V2	m - ft	2.21	7.25
V3	m - ft	0.53	1.74
V4	m - ft	8.92	29.27
W	m - ft	3.39	11.12

Ref.	Unit	Values
Y	deg.	10°
Z	deg.	107°
Turret rotation	deg.	400° or 360°

### ENGINE - Deutz TCD 3.6 L4 - 85 kW ST5

Table 142. ENGINE - Deutz TCD 3.6 L4 - 85 kW ST5

Description	Unit	Values
Engine brand		Deutz
Engine Type	Stage / Tier	EU Stage V / US EPA Tier 4
Engine model		TCD 3.6 L4
Fuel		Diesel
Injection system		Common rail
Firing orde		1 - 3 - 4 - 2
Bore	mm	98 - 3.86
Stroke	mm	120 - 4.72
Turbocharging System		Turbocharging with charge air cooling (air/air)
Turbocharger		Single turbo
Compression ratio		-
Nominal rate	rpm	2200
Idle rate	rpm	-
Maximum idle rate	rpm	-
Rated power (ISO/TR 14396)	Hp / kW @ rpm	116/85 @ 2200
Maximum torque	Nm - kgf @ rpm	460 @ 1600
Number of cylinders — Displacement	- cm <sup>3</sup> / l	4 - 3620
Main Coupling type		-
Additional service PTO (type, max torque)		-
Aftertreatment type		DPF + SCR
Volt - Batteries		(24V) 2x12V
<b>Cooling system</b>		
Water cooling		YES

### ELECTRICAL CIRCUIT

Table 143. Electrical circuit

Description	Unit	Values
Ground		Negative
Battery standard	V-Ah	2x12V - 120Ah/850A(EN)
Battery optional	V-Ah	2x12V - 180Ah/1235A(EN)
Voltage regulator		
Starting	V/AMP	24V / 5.0kW

## ELECTRONIC DEVICES

Table 144. Electronic devices

Description	Unit	Values
Stability system		YES
Stability System Approval certification		YES
Display (IHM)		8" MTA
Joysticks		Walvoil MTH

## HYDRAULIC CIRCUIT

Table 145. Hydrostatic circuit main pump

Description	Unit	Values
Supplier	Name	CASAPPA
Pump Type	Type	MPV48.53
Displacement maximum	(cm <sup>3</sup> )/rev	53
Flow rate @ 2200 rpm	l/min	116
Max continuous pressure	bar - psi	275 – 3988.54
Max peak pressure	bar - psi	315 – 4568.69

## HYDRAULIC MAIN VALVE FOR BOOM CONTROL

Table 146. Distributor

Description	Unit	Values	
		Values A	Values B
Supplier		WALVOIL	
Type		DPX 100	
Number of section		6	
Spool control		Open Loop Stepper	
Priority steering valve		Inlet Section	
Stabilizers circuit	l/min	117	117
	bar - psi	275 ±5 - 3988.54 ±72.52	275 ±5 - 3988.54 ±72.52
Slewing circuit	l/min	117	117
	bar - psi	275 ±5 - 3988.54 ±72.52	275 ±5 - 3988.54 ±72.52
Lifting circuit	l/min	117	117
	bar - psi	275 ±5 - 3988.54 ±72.52	275 ±5 - 3988.54 ±72.52
Extension circuit	l/min	10	117
	bar - psi	230 +13/-5 - 3335,87 +188.55/-72.52	275 ±5 - 3988.54 ±72.52
Tilting circuit	l/min	10	100
	bar - psi	280 + 20/-5 - 4061.06 +290.08/-72.52	230 - 3335.87
Optional circuit	l/min	65	65
	bar - psi	250 +13/-5 - 3625.94 +188.55/-72.52	250 +13/-5 - 3625.94 +188.55/-72.52

## TRANSMISSION

Table 147. Gearbox

Description	Unit	Values
Type of transmission		Hydrostatic
Number of gears (forward / reverse)		(2/2)
Maximum travel speed (unladen)	km / h	40
Drawbar pull (laden)	daN	9711.90
Parking brake		Automatic with negative action
Service brake	Hydraulic	Multi-disc type in oil bath integrated in the front and rear axles
Supplier		DANA
Type		367N
Gearbox ratio — ratio		1:1.09 - 1:4.53

Table 148. Front axle

Description	Unit	Values
Supplier		DANA
Type		Steer drive rigid axel 212 Cat 2
brakes		n8 FRICTION DISKS WELLMAN N266
Parking brakes		YES
Axle ratio		

Table 149. Rear axle

Description	Unit	Values
Supplier		DANA
Type		Steer drive rigid axel 212 Cat 2
brakes		n6 FRICTION DISKS WELLMAN N266
Parking brakes		NO
Axle ratio		

## STABILIZERS

Table 150. Stabilizers

Description	Values
Type of stabilizers	Spider type
Controls	Individual or simultaneous stabilizer controls

## STANDARD FRONT & REAR TIRES

Table 151. Tires

Description	Values
Type	ALLIANCE
Measurement	18-19.50 18 PR
Inflate pressure	7.50 bar (108.78 psi)

## OPTIONAL FRONT & REAR TIRES

Table 152. Tires

Description	Values
Type	CAMSO
Measurement	18-19.50
Inflate pressure	7.50 bar (108.78 psi)

## LIQUID CAPACITY

Description	Unit	Values	
<b>Tanks capacities</b>			
Motor oil	l - US gal	11	2.90
Hydraulic oil tank and transmission	l - US gal	150	39.62
Fuel tank	l - US gal	133	35.13
DEF (Diesel Emission Fluid) Tank	l - US gal	11	2.90
<b>Components capacities</b>			
Engine & Cooling circuit	l - US gal	25	6.60
Gear box	l - US gal	1.60	0.42
<b>Front axle</b>			
Differential (front/rear)	l - US gal	7	1.85
Hub reducers (each)	l - US gal	2	0.53
<b>Rear axle</b>			
Differential (front/rear)	l - US gal	7.80	2.06
Hub reducers (each)	l - US gal	0.80	0.21

## NOISE AND VIBRATIONS

Table 153. Noise and vibrations

Description	Unit	Values
Acoustic pressure in the driver's cabin LpA (according to NF EN 12053)	dB (A)	68
Guaranteed noise level in the environment LwA (according to Directive 2000/14 / EC modified by Directive 2005/88 / EC)	dB (A)	104
The weighted average acceleration transmitted to the boom system/ driver's hand (according to ISO 5349-2)	m / s <sup>2</sup>	< 2.50

## MISCELLANEOUS

Table 154. Miscellaneous

Description	Values
Driving wheels (front / rear)	2 / 2
Controls	2 Joysticks
Safety cabin approval	ROPS / FOPS (Level 2)
Attachment recognition system (E-Reco)	E-Reco

### 2.2.4.8 Technical datasheet MRT-X 2545



The specifications provided are not binding on the manufacturer and may be subject to change without prior notice.

## SPECIFICATIONS AND WEIGHTS

Table 155. Specifications and weights

Description	Unit	Values
<b>Driving speed</b>		
Maximum speed	km/h - mph	40 - 24.85
Maximum forward speed unload	km/h - mph	40 - 24.85
Maximum forward speed at nominal load	km/h - mph	5 - 3.11
Maximum reverse speed unload	km/h - mph	5 - 3.11
<b>Lifting capacity</b>		
Standard lifting height on tires with unladen forks	m - ft	16.30 - 53.48
Standard lifting height on stabs with unladen forks	m - ft	24.60 - 80.71
Lifting height at maximum capacity on tires	m - ft	10.30 - 33.79
Lifting height at maximum capacity on stabs	m - ft	11.40 - 37.40
Forward reach at maximum capacity on tires	m - ft	5.50 - 18.04
Forward reach at maximum capacity on stabs	m - ft	6.60 - 21.65
Forward reach with fork-carrier and standard forks	m - ft	19.50 - 63.98
Maximum rated capacity with standard carriage and forks on stabilizers	kg - lb	4500 - 9920.80
Distance from center of gravity	mm - in	500 - 19.68
Capacity at maximum height with standard carriage and forks on tires frontal	kg - lb	1000 - 2204.62
Capacity at maximum height with standard carriage and forks on stab	kg - lb	2000 - 4409.25
Capacity at maximum reach with standard carriage and forks on tires frontal	kg - lb	300 - 661.39
Capacity at maximum reach with standard carriage and forks on stabs	kg - lb	300 - 661.39
<b>Standard carriage and forks</b>		
Type		PFB 1320
Fork dimensions	mm - in	1200 x 125 x 50 - 47.24 x 4.92 x 1.97
<b>Weight distribution with standard carriage and forks</b>		
Vehicle weight (unloaded)	kg - lb	15910 - 35075.55
<b>Ground pressure</b>		
Maximum load ground pressure on stabilizer (laden)	kg/cm <sup>2</sup>	8.81
Maximum load ground pressure on tire (unladen)	kg/cm <sup>2</sup>	-
Maximum load on each stabilizer	kg - lb	11005 - 24261.87
Maximum load on tire	kg - lb	-
<b>Stabilizers</b>		
Type		1 foxed pivot + 1 mobile pivot
System of control		Electrohydraulic valve
Type of control in CAB		CAN-BUS switch
<b>Gradeability</b>		
Unloaded	%	48.70
Loaded	%	49.80

<b>Boom</b>		
<b>Number of elements</b>		4
<b>Type of movement (chain, cylinder...)</b>		Cylinder 1° and chain others
<b>Drawbar pull</b>		
<b>Tractive force (Drawbarpull)</b>	daN	9711.90
<b>Break out force with bucket (according to standard ISO 8313)</b>	daN	-
<b>Hydraulic motions speeds</b>		
<b>Unladen lifting</b>	sec	27
<b>Laden lifting</b>	sec	-
<b>Unladen lowering</b>	sec	18.50
<b>Laden lowering</b>	sec	-
<b>Unladen extending</b>	sec	35
<b>Laden extending</b>	sec	
<b>Unladen retracting</b>	sec	30
<b>Laden retracting</b>	sec	-
<b>Reverse tilt time unladen</b>	sec	6
<b>Forward tilt time unladen</b>	sec	5
<b>Turret rotation clockwise (360°)</b>	sec	90
<b>Turret rotation counterclockwise (360°)</b>	sec	90
<b>Hydraulic circuit main-componets</b>		
<b>Locking rear axle</b>		YES
<b>Stabilizers</b>		1 cylinder for each stabilizer
<b>Low pressure valve</b>	bar - psi	270 – 3916.02
<b>Steering mode selector</b>		YES
<b>Frame levelling</b>		NO

WEIGHT AND DIMENSIONS

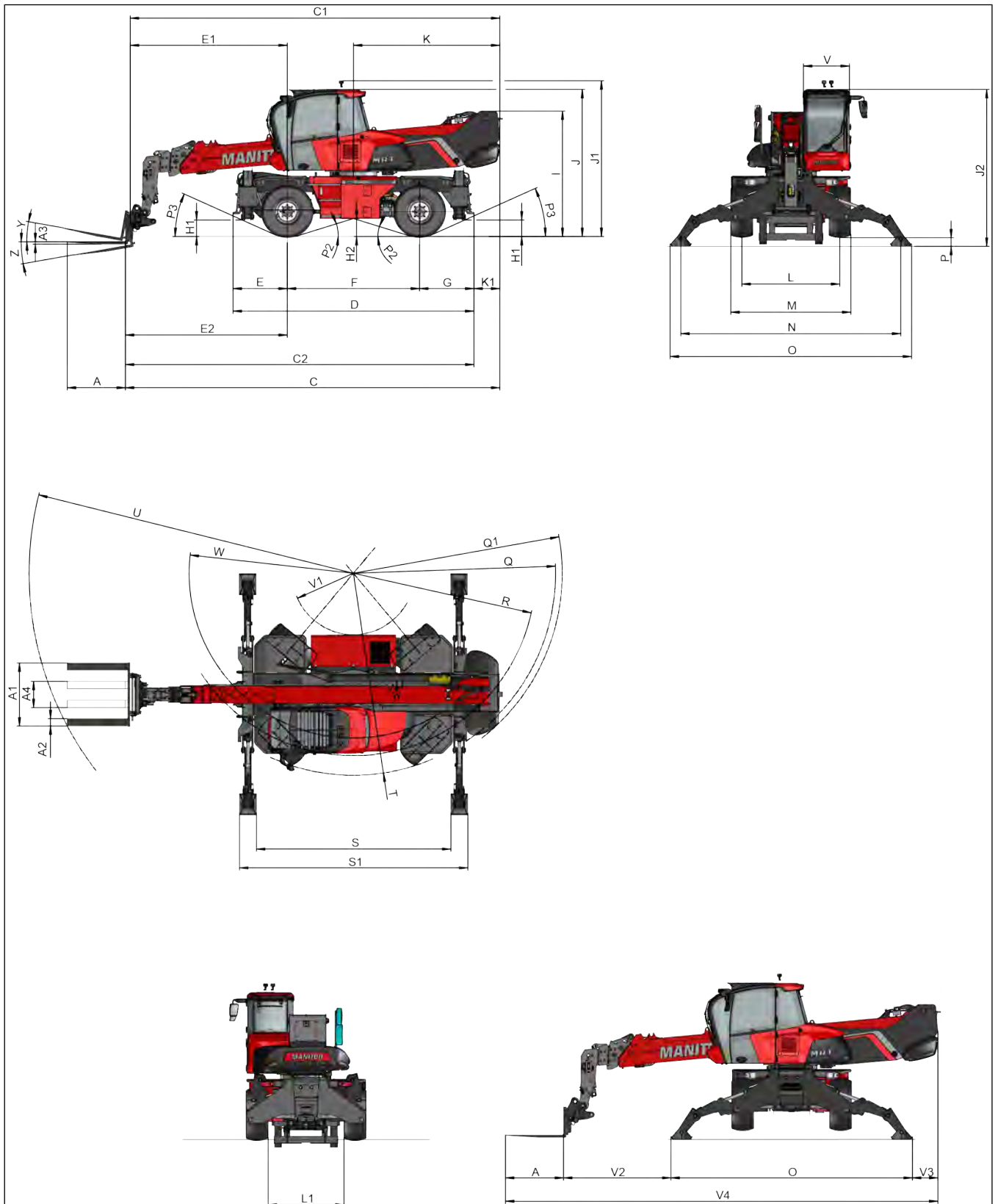


Figure 78: Dimensions (side, front and top view)

Table 156. Weight and dimensions

<b>Ref.</b>	<b>Unit</b>	<b>Values</b>	
A	m - ft	1.20	3.94
A1	m - ft	1.30	4.27
A2	m - ft	0.15	0.49
A3	m - ft	0.05	0.16
A4	m - ft	0.54	1.77
B	m - ft	-	-
C	m - ft	7.72	25.33
C1	m - ft	7.62	25
C2	m - ft	7.19	23.59
D	m - ft	4.97	16.31
E	m - ft	1.12	3.67
E1	m - ft	3.24	10.63
E2	m - ft	3.34	10.96
F	m - ft	2.73	8.96
G	m - ft	1.12	3.67
G1	deg.	-	-
G2	deg.	-	-
H1	m - ft	0.34	1.12
H2	m - ft	0.37	1.21
I	m - ft	2.59	8.50
J	m - ft	3.04	9.97
J1	m - ft	3.21	10.53
J2	m - ft	3.24	10.63
K	m - ft	3.02	9.91
K1	m - ft	0.53	1.74
L	m - ft	2.02	6.63
L1	m - ft	1.56	5.12
M	m - ft	2.48	8.14
N	m - ft	4.54	14.90
O	m - ft	4.98	16.34
P	m - ft	0.18	0.59
P2	deg.	17°	-
P3	deg.	24°	-
Q	m - ft	4.17	13.68
Q1	m - ft	4.31	14.14
R	m - ft	3.76	12.34
S	m - ft	4.01	13.16
S1	m - ft	4.71	15.45
T	m - ft	4.16	13.65
U	m - ft	6.69	21.95
V	m - ft	0.96	3.15
V1	m - ft	1.26	4.13
V2	m - ft	2.21	7.25
V3	m - ft	0.53	1.74
V4	m - ft	8.92	29.27
W	m - ft	3.39	11.12

Ref.	Unit	Values
Y	deg.	10°
Z	deg.	107°
Turret rotation	deg.	400°

### ENGINE - Deutz TCD3.6 EDG - 85 kW ST3A

Table 157. ENGINE - Deutz TCD3.6 EDG - 85 kW ST3A

Description	Unit	Values
Engine brand		Deutz
Engine Type	Stage / Tier	Stage 3A
Engine model		TCD3.6 EDG
Fuel		Diesel
Injection system		Common rail
Firing orde		1 - 3 - 4 - 2
Bore	mm	98 - 3.86
Stroke	mm	120 - 4.72
Turbocharging System		Turbocharging with charge air cooling (air/air)
Turbocharger		Single turbo
Compression ratio		-
Nominal rate	rpm	2200
Idle rate	rpm	-
Maximum idle rate	rpm	-
Rated power (ISO/TR 14396)	Hp / kW @ rpm	116/85 @ 2200
Maximum torque	Nm - kgf @ rpm	460 @ 1600
Number of cylinders — Displacement	- cm <sup>3</sup> / l	4 - 3620
Main Coupling type		-
Additional service PTO (type, max torque)		-
Aftertreatment type		NO
Volt - Batteries		(24V) 2x12V
<b>Cooling system</b>		
Water cooling		YES

### ELECTRICAL CIRCUIT

Table 158. Electrical circuit

Description	Unit	Values
Ground		Negative
Battery standard	V-Ah	2x12V - 120Ah/850A(EN)
Battery optional	V-Ah	2x12V - 180Ah/1235A(EN)
Voltage regulator		
Starting	V/AMP	24V / 5.0kW

## ELECTRONIC DEVICES

Table 159. Electronic devices

Description	Unit	Values
Stability system		YES
Stability System Approval certification		YES
Display (IHM)		8" MTA
Joysticks		Walvoil MTH

## HYDRAULIC CIRCUIT

Table 160. Hydrostatic circuit main pump

Description	Unit	Values
Supplier	Name	CASAPPA
Pump Type	Type	MPV48.53
Displacement maximum	(cm <sup>3</sup> )/rev	53
Flow rate @ 2200 rpm	l/min	116
Max continuous pressure	bar - psi	275 – 3988.54
Max peak pressure	bar - psi	315 – 4568.69

## HYDRAULIC MAIN VALVE FOR BOOM CONTROL

Table 161. Distributor

Description	Unit	Values	
		Values A	Values B
Supplier		WALVOIL	
Type		DPX 100	
Number of section		6	
Spool control		Open Loop Stepper	
Priority steering valve		Inlet Section	
Stabilizers circuit	l/min	117	117
	bar - psi	275 ±5 - 3988.54 ±72.52	275 ±5 - 3988.54 ±72.52
Slewing circuit	l/min	117	117
	bar - psi	275 ±5 - 3988.54 ±72.52	275 ±5 - 3988.54 ±72.52
Lifting circuit	l/min	117	117
	bar - psi	275 ±5 - 3988.54 ±72.52	275 ±5 - 3988.54 ±72.52
Extension circuit	l/min	10	117
	bar - psi	230 +13/-5 - 3335,87 +188.55/-72.52	275 ±5 - 3988.54 ±72.52
Tilting circuit	l/min	10	100
	bar - psi	280 + 20/-5 - 4061.06 +290.08/-72.52	230 - 3335.87
Optional circuit	l/min	65	65
	bar - psi	250 +13/-5 - 3625.94 +188.55/-72.52	250 +13/-5 - 3625.94 +188.55/-72.52

## TRANSMISSION

Table 162. Gearbox

Description	Unit	Values
Type of transmission		Hydrostatic
Number of gears (forward / reverse)		(2/2)
Maximum travel speed (unladen)	km / h	40
Drawbar pull (laden)	daN	9711.90
Parking brake		Automatic with negative action
Service brake	Hydraulic	Multi-disc type in oil bath integrated in the front and rear axles
Supplier		DANA
Type		367N
Gearbox ratio — ratio		1:1.09 - 1:4.53

Table 163. Front axle

Description	Unit	Values
Supplier		DANA
Type		Steer drive rigid axel 212 Cat 2
brakes		n8 FRICTION DISKS WELLMAN N266
Parking brakes		YES
Axle ratio		

Table 164. Rear axle

Description	Unit	Values
Supplier		DANA
Type		Steer drive rigid axel 212 Cat 2
brakes		n6 FRICTION DISKS WELLMAN N266
Parking brakes		NO
Axle ratio		

## STABILIZERS

Table 165. Stabilizers

Description	Values
Type of stabilizers	Spider type
Controls	Individual or simultaneous stabilizer controls

## STANDARD FRONT & REAR TIRES

Table 166. Tires

Description	Values
Type	ALLIANCE
Measurement	18-19.50 18 PR
Inflate pressure	7.50 bar (108.78 psi)

## OPTIONAL FRONT & REAR TIRES

Table 167. Tires

Description	Values
Type	CAMSO
Measurement	18-19.50
Inflate pressure	7.50 bar (108.78 psi)

## LIQUID CAPACITY

Description	Unit	Values	
<b>Tanks capacities</b>			
Motor oil	l - US gal	11	2.90
Hydraulic oil tank and transmission	l - US gal	150	39.62
Fuel tank	l - US gal	133	35.13
<b>Components capacities</b>			
Engine & Cooling circuit	l - US gal	25	6.60
Gear box	l - US gal	1.60	0.42
<b>Front axle</b>			
Differential (front/rear)	l - US gal	7	1.85
Hub reducers (each)	l - US gal	2	0.53
<b>Rear axle</b>			
Differential (front/rear)	l - US gal	7.80	2.06
Hub reducers (each)	l - US gal	0.80	0.21

## NOISE AND VIBRATIONS

Table 168. Noise and vibrations

Description	Unit	Values
Acoustic pressure in the driver's cabin LpA (according to NF EN 12053)	dB (A)	68
Guaranteed noise level in the environment LwA (according to Directive 2000/14 / EC modified by Directive 2005/88 / EC)	dB (A)	104
The weighted average acceleration transmitted to the boom system/ driver's hand (according to ISO 5349-2)	m / s <sup>2</sup>	< 2.50

## MISCELLANEOUS

Table 169. Miscellaneous

Description	Values
Driving wheels (front / rear)	2 / 2
Controls	2 Joysticks
Safety cabin approval	ROPS / FOPS (Level 2)
Attachment recognition system (E-Reco)	E-Reco

### 2.2.5 CAPACITY AND LOAD CHARTS

The following pages show the load charts of each machine model with the standard attachment CAF 1030 (fork carrier).

**MRT 1645 400 75D ST5 S1 + CAF1030/4.5T F100X60X1200 B (standard)**  
**MRT 1645 400 115D ST5 S1 / MRT-X 1645 400 115D ST5 S1 + CAF1030/4.5T F100X60X1200 B (standard)**

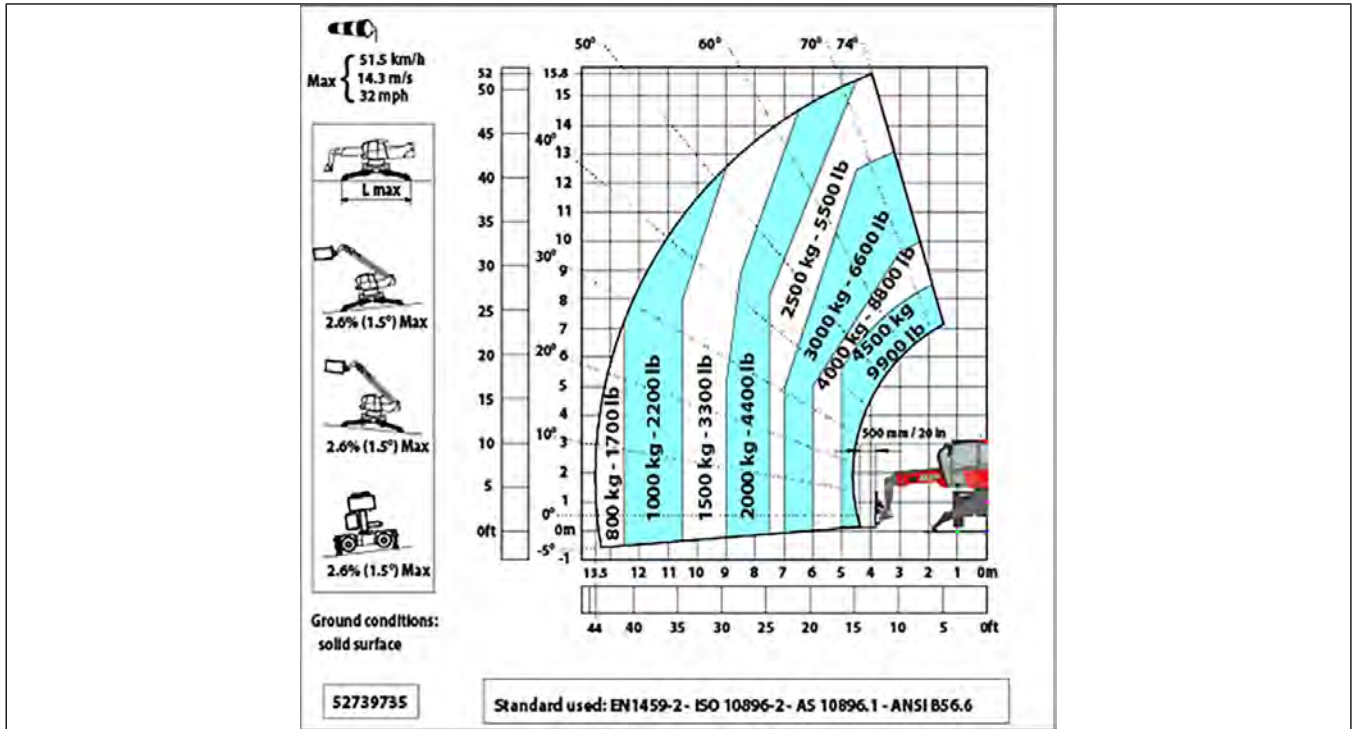


Figure 79: Working condition: on stabilizers

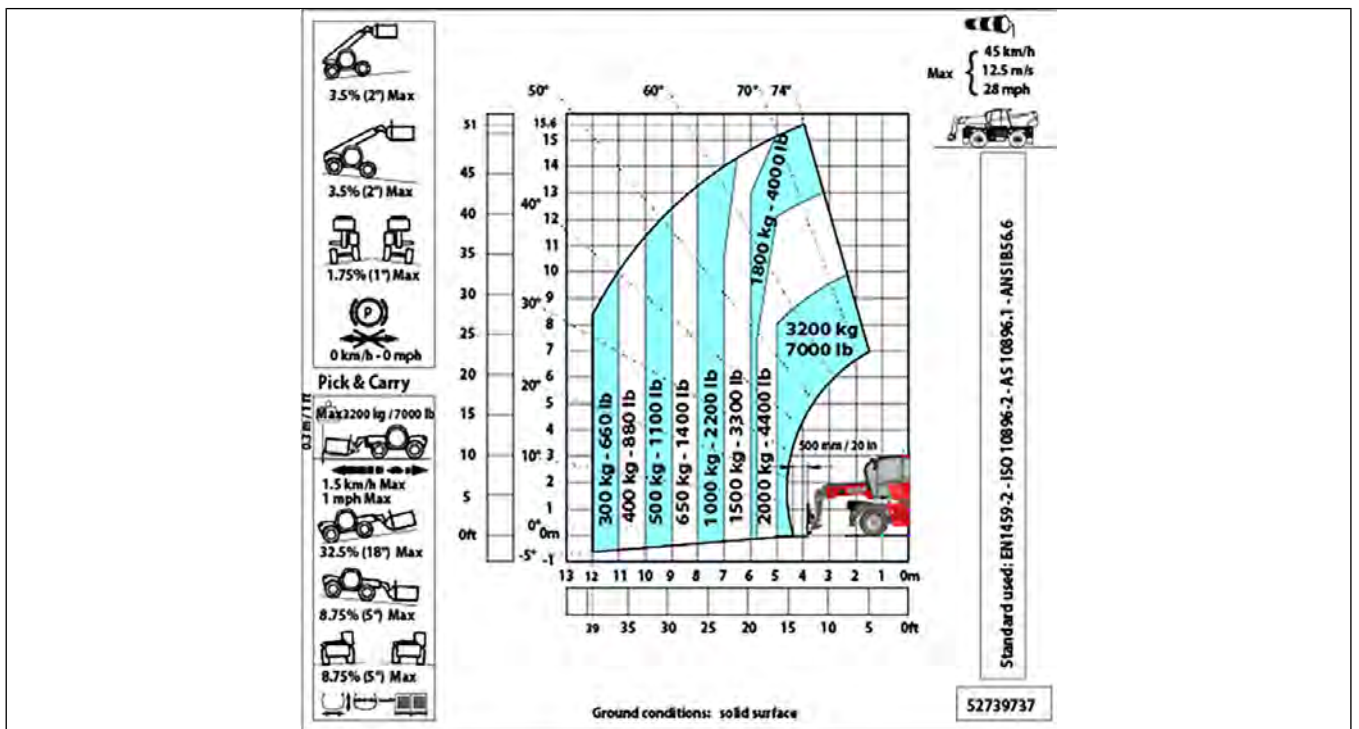


Figure 80: Working condition: on tires (front turret)

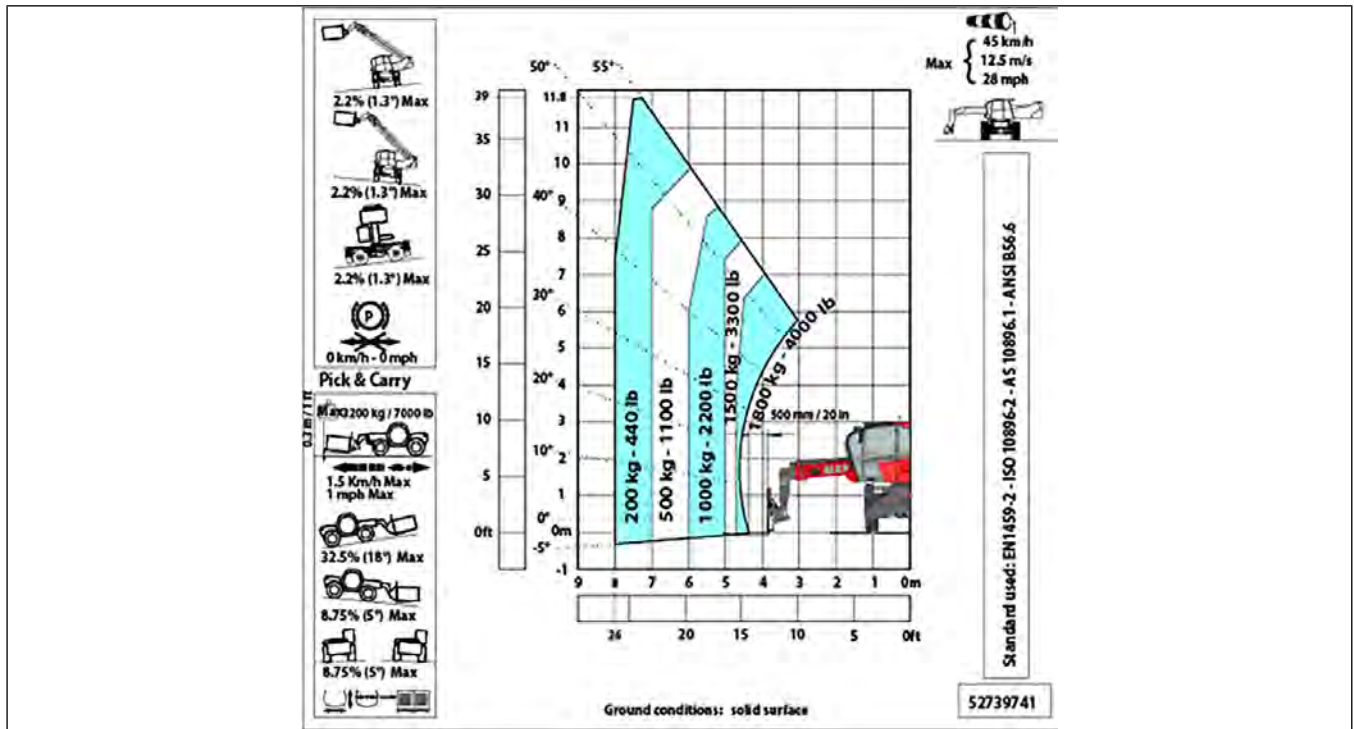


Figure 81: Working condition: on tires (turret rotated)

**MRT 1845 400 75D ST5 S1 / MRT 1845 360 75D ST5 S1 + CAF1030/4.5T F100X60X1200 B (standard)**  
**MRT 1845 400 115D ST5 S1 / MRT-X 1845 400 115D ST5 S1 + CAF1030/4.5T F100X60X1200 B (standard)**

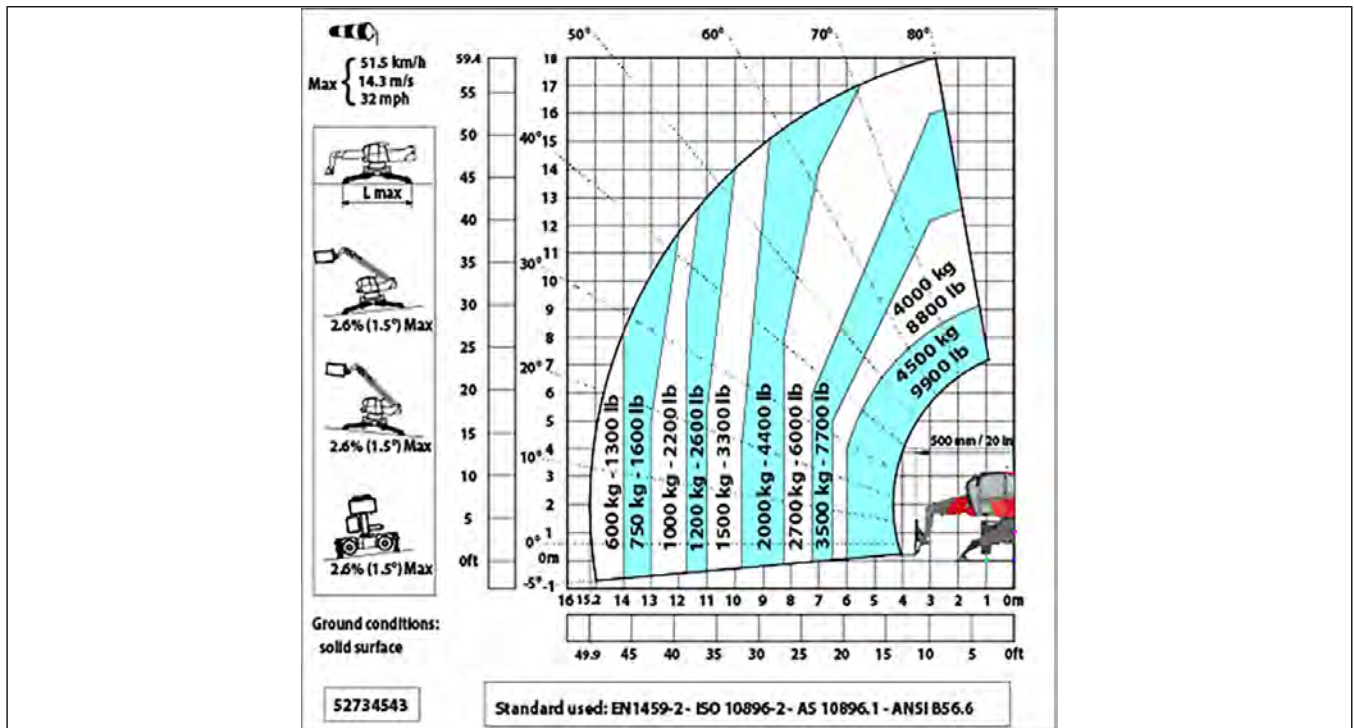


Figure 82: Working condition: on stabilizers

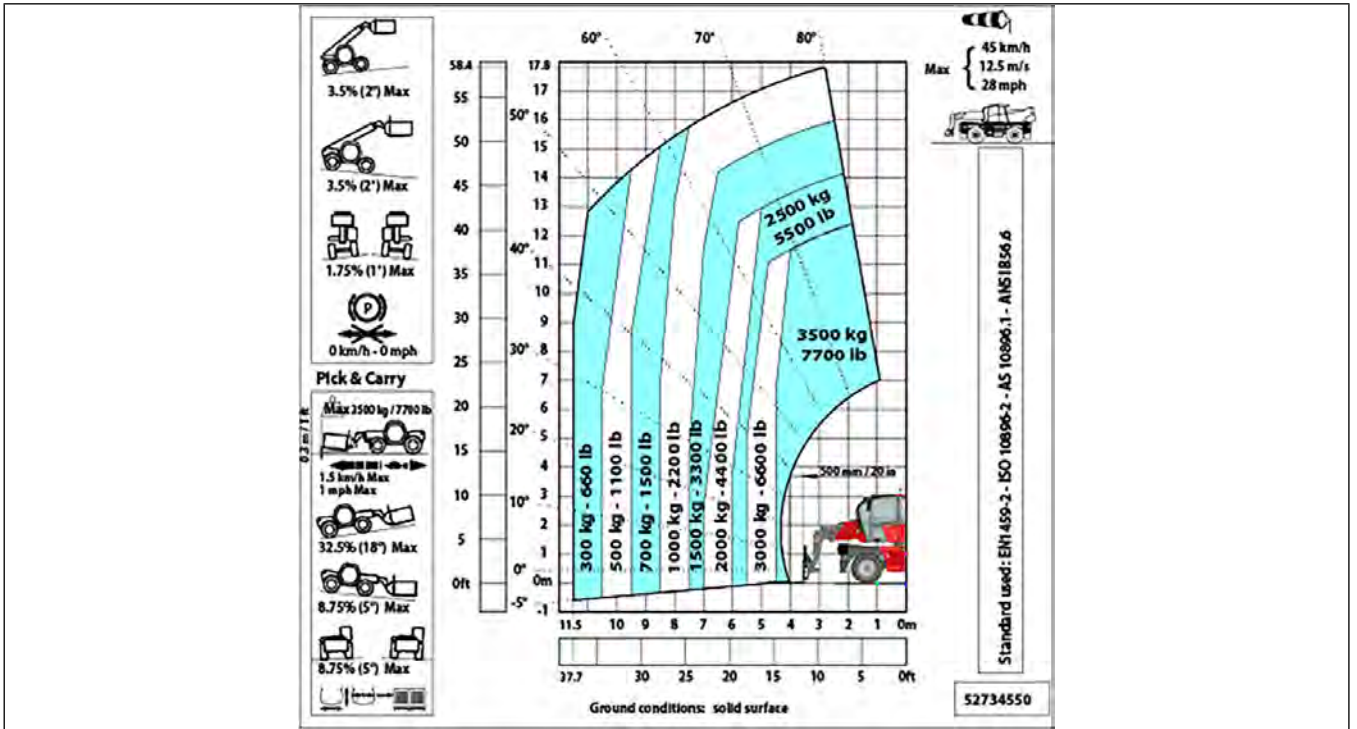


Figure 83: Working condition: on tires (front turret)

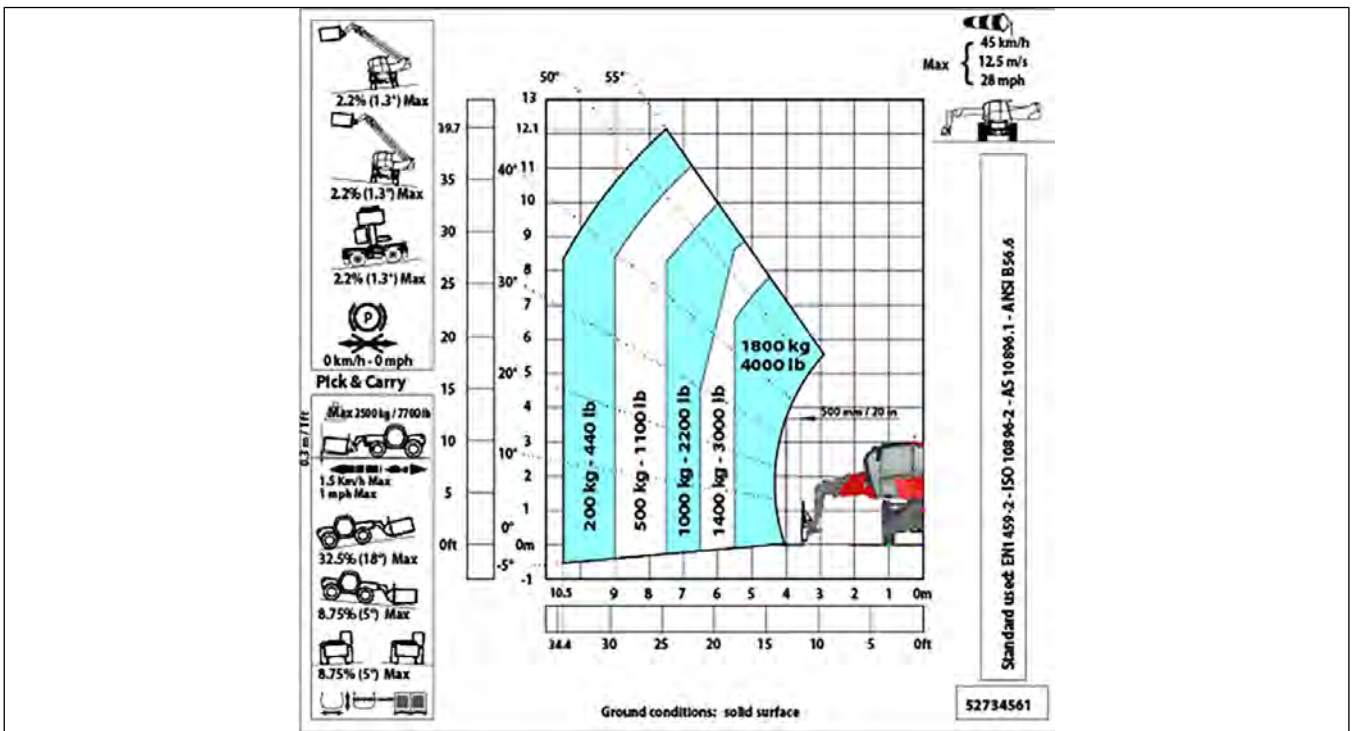


Figure 84: Working condition: on tires (turret rotated)

MRT 2145 360 115D ST5 S1 / MRT-X 2145 360 115D ST5 S1 + CAF1030/4.5T F100X60X1200 B (standard)

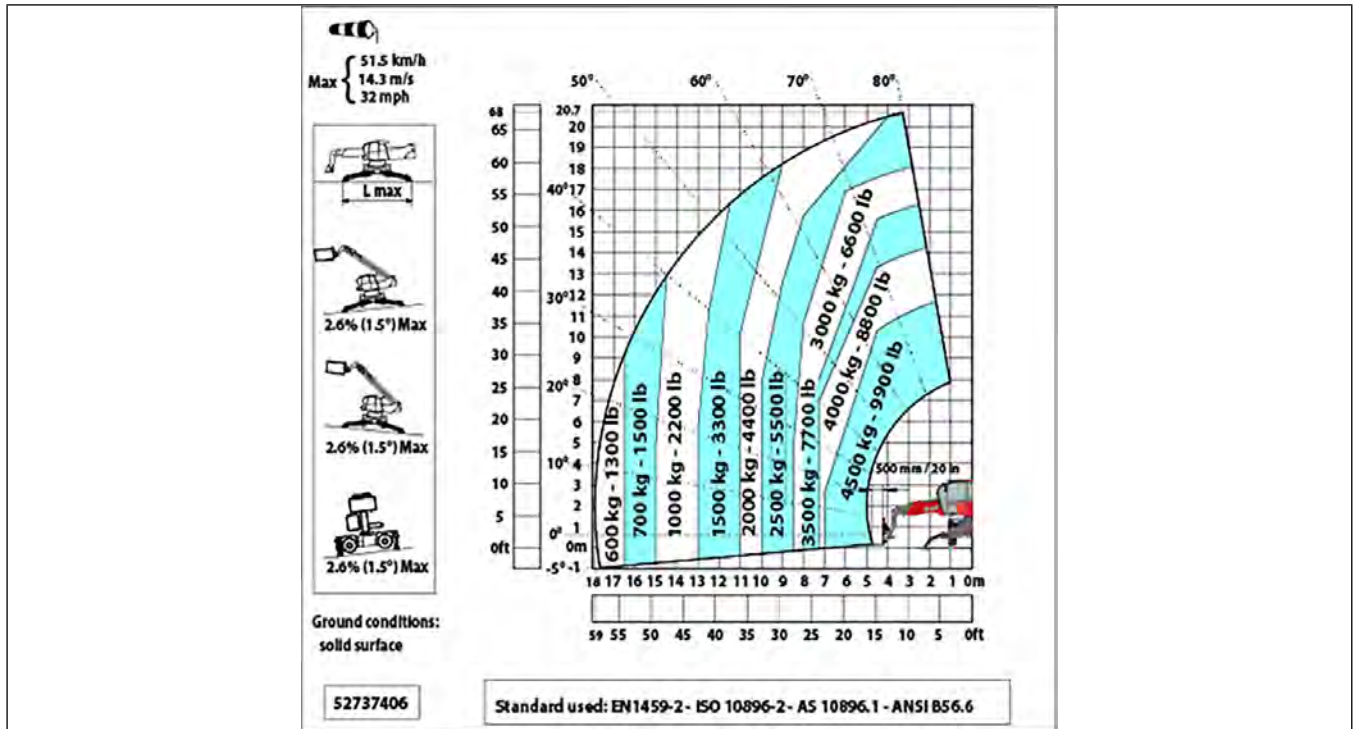


Figure 85: Working condition: on stabilizers

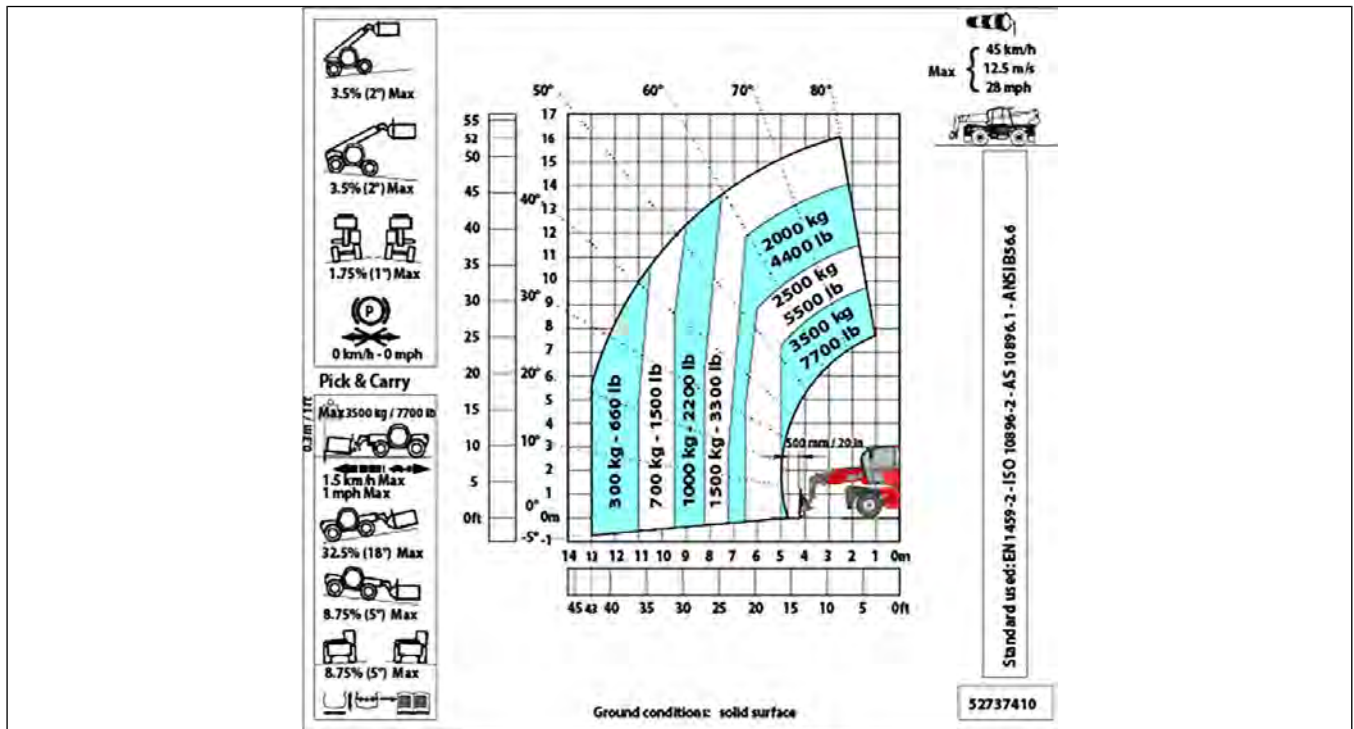


Figure 86: Working condition: on tires (front turret)

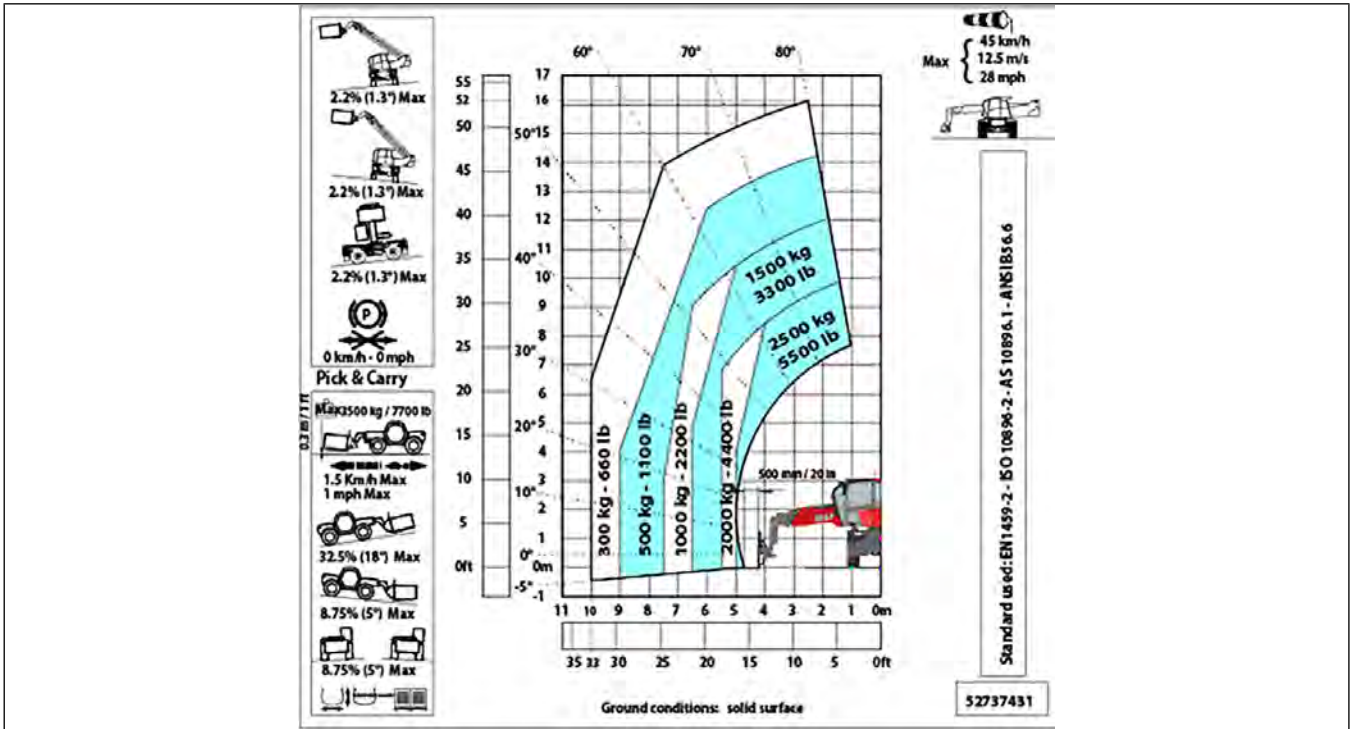


Figure 87: Working condition: on tires (turret rotated)

**MRT 2545 360 115D ST5 S1 / MRT-X 2545 360 115D ST5 S1 + CAF1030/4.5T F100X60X1200 B (standard)**

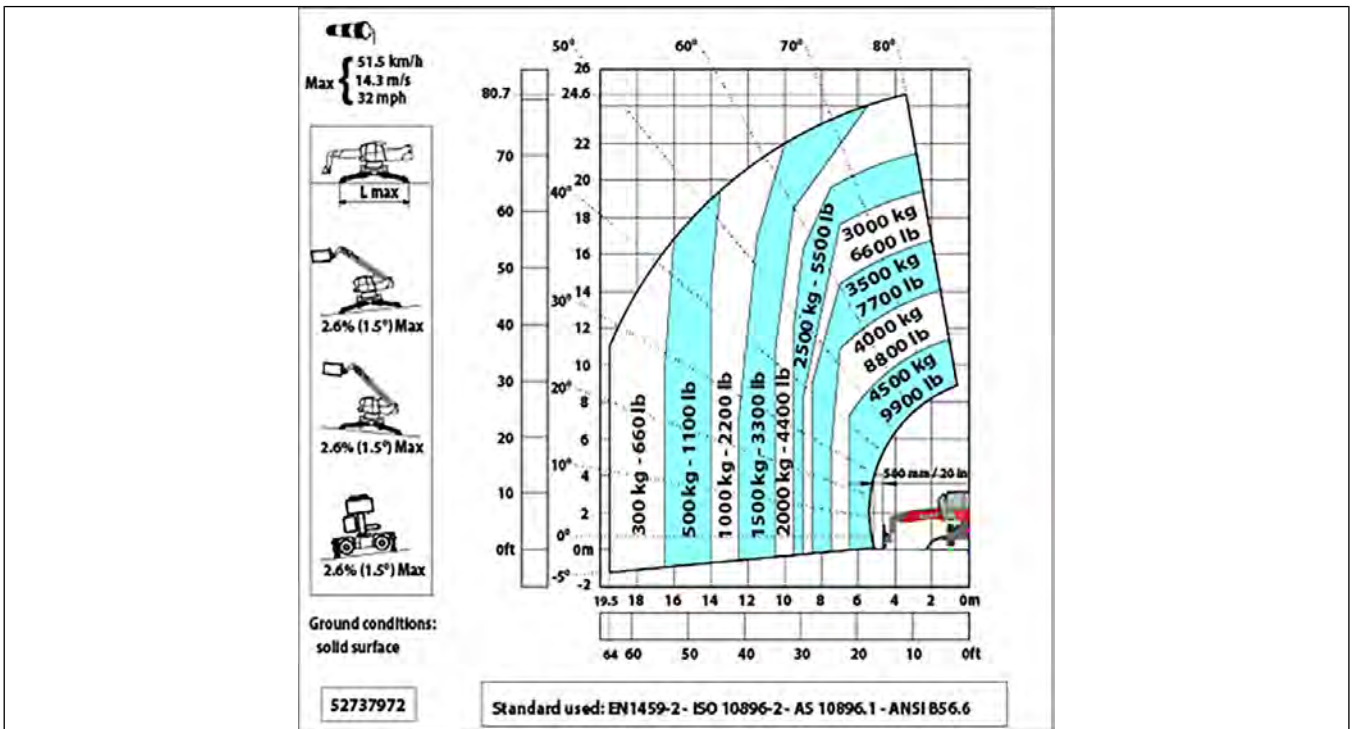


Figure 88: Working condition: on stabilizers

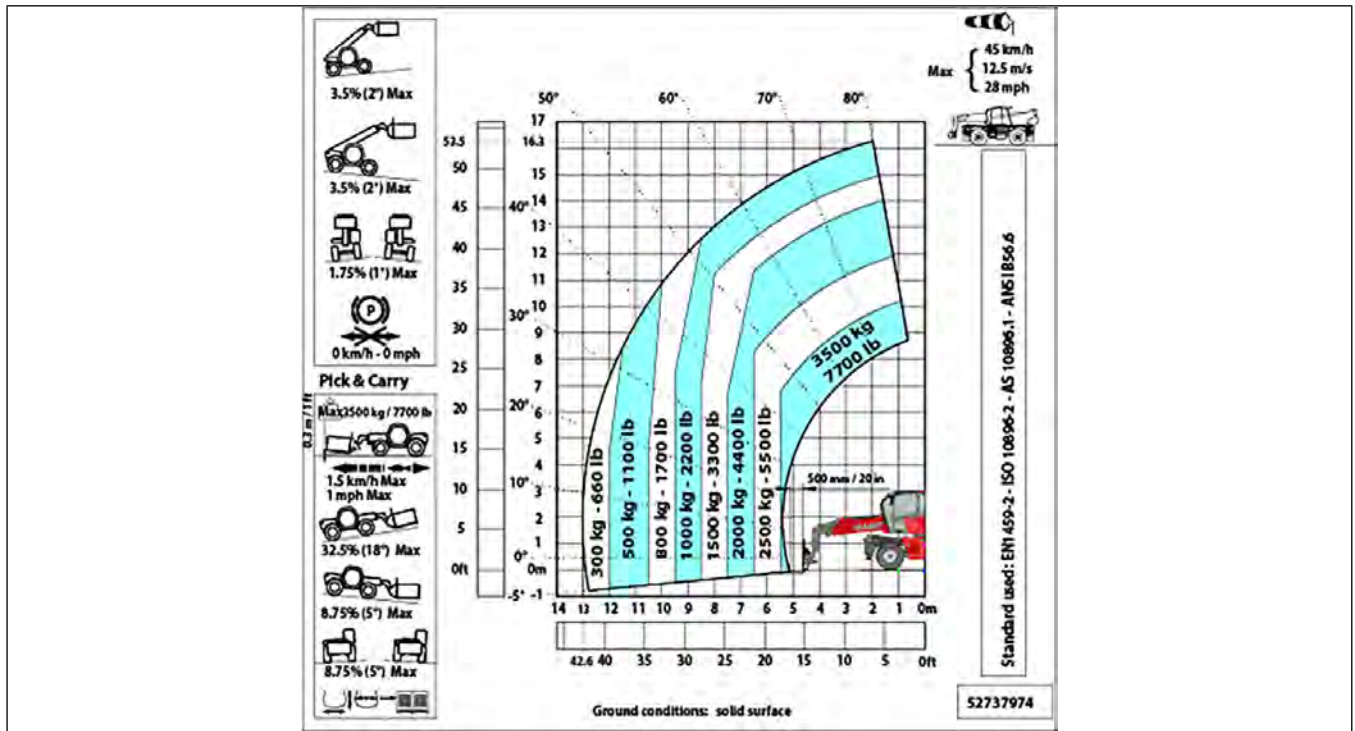


Figure 89: Working condition: on tires (front turret)

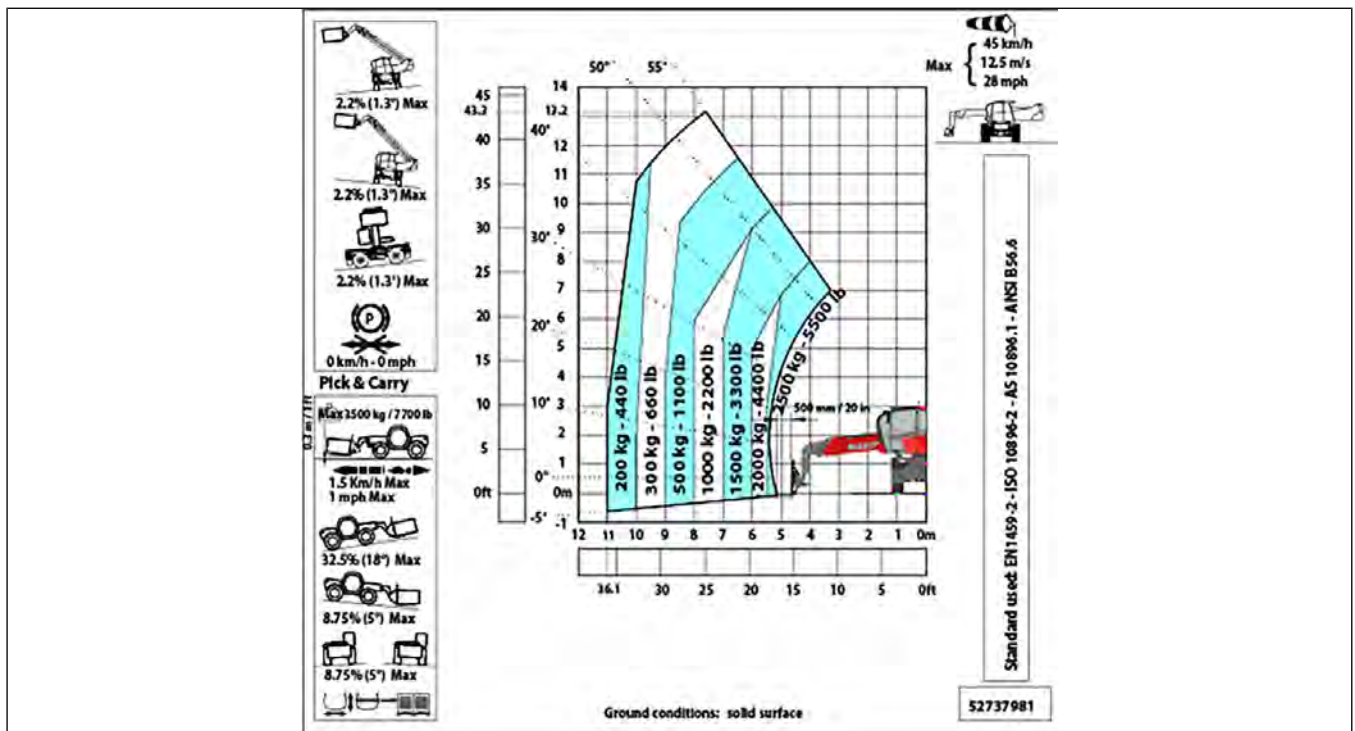


Figure 90: Working condition: on tires (turret rotated)

## 2.3. ENVIRONMENT

### 2.3.1 EXHAUST GAS AFTERTREATMENT SYSTEM (DOC/DPF+SCR)




#### MAIN COMPONENTS SYSTEM (DOC/DPF +SCR)



- DEF Tank
- DEF supply pump
- DOC/DPF Diesel particle filter
- SCR catalytic converter

### SYSTEM OPERATION (DOC/DPF+SCR)

This system controls and reduces the harmful emissions of the exhaust gas produced by the engine.

- In order to comply with the regulations of the European Union (EU) and the Environmental Protection Agency (EPA), the system (DOC/DPF +SCR) reacts with a warning strategy to faulty operation of the exhaust gas aftertreatment system. Emission-relevant faults are:
  - DEF (Diesel Exhaust Fluid) filling level
  - Catalytic converter efficiency/DEF quality
  - Manipulation
  - System fault
- If a serious fault occurs or a fault is not remedied, the system (DOC/DPF +SCR) reacts by reducing the engine performance.
- A separate emergency command (Override function) has been provided, in order to temporarily disable power reductions caused by the system (DOC/ DPF +SCR). This function is available for a limited period and is expected to enable the user to move the machine to a safe location. This function is available for engines with power reduction levels 1 and 2, in accordance with EU legislation, and with power reduction level 1, in accordance with EPA legislation.
- The SCR system is monitored for possible formation and build-up of crystals (crystallisation). As soon as crystallisation is detected, a standstill regeneration request is issued. This is displayed by a flashing regeneration lamp. The standstill regeneration must be initiated by the operator. It is recommended that standstill regeneration be undertaken as soon as possible. If standstill regeneration is not undertaken, the engine control unit will activate the specified engine protection functions. Every standstill regeneration slightly dilutes the engine oil with fuel. The number of standstill regenerations is therefore monitored.
- On the control panel in the cab, the display and monitoring of the System (DOC/DPF +SCR) is executed with pilot lights. Pilot lights overview:

	SCR function lamp (measure: check DEF filling level and check SCR system)
	DPF regeneration in progress / high temperature lamp
	DPF regeneration lamp (measure : initiate standstill regeneration)

	Ash lamp (measure: indicates that the loading of the diesel particle filter with incombustible residues has reached a critical level and must be replaced).
	Generic alarm warning lamp

### ENGINE REDUCTION LEVELS

The legislation requirement of the European Union (EU) and the Environmental Protection Agency (EPA) are the system reactions in case of violation of proper system functionality.

### Inducement Strategies for EU/EPA

Due to significant differences in the required performance restrictions in EU and EPA legislation, strategies are used depending on the engine certificate (EU or EPA/CARB). The inducement strategy fulfills the legislation and may exceed the minimum requirements of the law. Wording used in the following sections:

	<i>EU Legislation</i>	<i>EPA Legislation</i>
Derating Step 1	Low level inducement	Low level inducement
Derating Step 2	Severe inducement	Final inducement

### EU Legislation

For EU applications a two stage inducement system is used. As soon as a relevant error is detected the operator is informed with an EAT related warning message.

- **Derating Step 1 (EU)**  
This warning is followed by a low-level inducement (derating step 1), which reduces the available engine torque by 25 % in the whole operating range of the engine. The torque reduction becomes active with a ramp of 10 % per minute.
- **Derating Step 2 (EU)**  
If the error remains active the low-level inducement is followed by a severe inducement (derating step 2). The available torque is limited to 50 % of maximum engine torque and the maximum engine speed is limited to 60% of rated engine speed minus droop so that with no load 60% of rated speed is not exceeded. The torque reduction becomes active with a ramp of 10% per minute. The engine speed reduction becomes active with 360 rpm per minute.
- **Inducement Override (EU)**  
Due to the EXHAUST GAS AFTERTREATMENT SYSTEM (DOC/DPF +SCR) related inducements

the vehicle operation may be strongly limited. However a limp home operation is available to be able to operate the machine in case of any emergency. Therefore temporary override functionality is available for a limited time period. This function releases the full engine power and enables the operator to move the machine to a safe place or back to the workshop. The override functionality can be requested three times during each period that the operator inducement system is active. Each single "override" activation is limited to 30 minutes. The restored operation can be activated by an override command or by Customer Service. The system reacts on a rising edge of the input and starts the time counter. If the engine is shut off during an override period, the remaining time will be stored and can be used after restarting the engine. The counter will only be reset if the system passes all internal tests without an error and the repeated occurrence time is over.

## NOTICE

The "override" function is possible in the EU variant either during step 1 or during step 2.

- **Repeated Occurrence (EU)**

Time counters for activating derating step 1 and 2 will be frozen after healing or resetting an error. But also the timer for inducement override will be frozen. If an error of the group quality or tampering reoccurs within a period of 40 operating hours, the counters will continue with the frozen value. If derating step 2 was already active when the error was healed, it will become active again after 2h for Quality or 5h for Tampering. The inducement level 2h or 5h before severe inducement becomes active.

**SCR-SYSTEM (EU)**

**DEF-Level Monitoring (EU)**



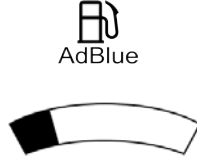


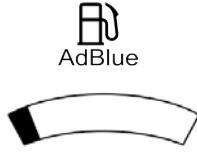


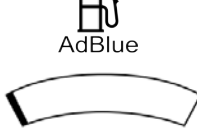



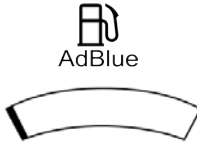



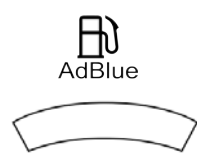



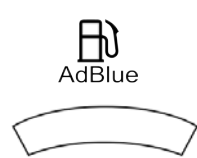



If no DEF additive is available in the DEF tank, the emission requirements cannot be fulfilled and therefore an inducement must be activated.

Three error messages are available representing the monitoring steps with active engine limitations.

**NOTICE**

The override of the errors which belong to the “Level” is possible considering above mentioned limitations.

DEF level monitoring escalation steps:

Level	Level indicator	DEF Lamp (flashing speed)	Warning Lamp (behavior)	Buzzer	System Reaction (EU)
		Symbol	Symbol		Operator Actions
>15%		-	-		-
		-	-		-
<15%		(solid on)	-		-
		 Level < 15%	-		fill the def tank
<10%		(slow)	-		-
		 Level < 10%	-		fill the def tank
<5%		(flashing)	(solid on)		-
		 restriction			refill the def tank
10 min after level < 5%		(medium)	(solid on)		derating step 1 active
		 restriction			carry out the override + refill the def tank
15 min after level < 5%		(fast)	(blinking)		derating step 1 active
		 restriction			carry out the override + refill the def tank
20 min after level < 5%		(fast)	(blinking)		derating step 2 active
		 restriction			call for service

The machine is fully restored to normal functionality and operation when a tank fill is performed and indicated. A tank fill is assumed when the level

exceeds the Reduction level 1 trigger level. If the filled DEF level does not exceed the initial warning level (<10%), the operator warning system remains active.

### Group DEF Quality (EU)

If the DEF quality requirements, or too high NOx emissions are observed, or a system error causes not sufficient DEF injection, then the engine exhaust emissions cannot be observed.

The DEF Quality monitoring offers four escalation steps. A first warning is displayed as soon as an error is detected.

## NOTICE

The override of the errors which belong to the “DEF Quality” is possible considering above mentioned limitations.

DEF Quality escalation steps:

DEF Quality	DEF Lamp (flashing speed)	Warning Lamp (behavior)	Buzzer	System Reaction (EU)
	Symbol	Symbol		Operator Actions
Normal	-	-		-
	-	-		-
Too low	(solid on)	(solid on)		-
				-
Too low inducement Pretrigger 1	(solid on)	(solid on)		no derating active 9 h 50 min after detection
				carry out the override + call for service
Too low	(solid on)	(solid on)		derating step 1 active 10 h after detection
				carry out the override + call for service
Too low inducement Pretrigger 2	(solid on)	(blinking)		derating step 1 active 19 h 50 min after detection
				carry out the override + call for service
Too low	(solid on)	(blinking)		derating step 2 active 20 h after detection
				call for service

The SCR-system could be damaged if DEF not according to specification is used in the system. Additive quality complying with ISO 22241 must be used.

Dilution of the DEF with water will lead to deteriorated NOx reduction and clogging of the catalyst with resulting damage to the SCR-system.

Misfilling with diesel will lead to injection of diesel together with Additive into the catalyst with very high

combustion temperatures as a result that will damage the catalyst.

Out-off specification additive must be detected as soon as possible, maximally within 30 minutes. As

### Group Anti Tampering (EU)

Monitoring of selected system failures is required because they may be attributed to tampering.

The operator information shall include specific information about which part of the EXHAUST GAS AFTERTREATMENT SYSTEM (DOC/DPF +SCR) is exposed to tampering, so that possible reparation of the system is facilitated.

















The Anti-Tampering monitoring offers four escalation steps. A first warning is displayed as soon as a tampering is detected.

soon as poor quality additive is detected a warning will be activated. The sooner the operator is notified, the better the chance to easily remedy the problem.

## NOTICE

The override of the errors which belong to the “Tampering” is possible considering above mentioned limitations.

Anti Tampering escalation steps:

Anti-Tampering	DEF Lamp (flashing speed)	Warning Lamp (behavior)	Buzzer	System Reaction (EU)
	Symbol	Symbol		Operator Actions
Normal	-	-		-
	-	-		-
Failure detected	(solid on)	(solid on)		-
				-
Failure detected inducement Pretrigger 1	(solid on)	(solid on)		no derating active 35 h 50 min after detection
	 restriction			carry out the override + call for service
Failure detected	(solid on)	(solid on)		derating step 1 active 36 h after detection
	 restriction			carry out the override + call for service
Failure detected inducement Pretrigger 2	(solid on)	(blinking)		derating step 1 active 99 h 50 min after detection
	 restriction			carry out the override + call for service
Failure detected	(solid on)	(blinking)		derating step 2 active 100 h after detection
	 restriction			call for service

### Group Hardware Failure (EU)








Hardware failures are errors of the EAT components, e.g. defects of the urea pump.

In case of Hardware failure the Urea Warning Lamp and the general error lamp are permanently active.

## NOTICE

For the errors in the group “Hardware”, it’s generally no override possible!

Hardware Failure escalation steps:

Hardware Failure	DEF Lamp (flashing speed)	Warning Lamp (behavior)	Buzzer	System Reaction (EU)
	Symbol	Symbol		Operator Actions
Normal	-	-		-
	-	-		-
Failure detected Inducement pretrigger	(solid on)	(blinking)		no derating
				call for service
Failure detected	(solid on)	(blinking)		derating step 2 active 10 min after detection
	 restriction			call for service

### Crystallization Detection (EU)

The SCR system is monitored for crystallization.











If crystallization is detected, the system can request a standstill as countermeasure.

If the operator ignores the standstill request, a specific error message will be created and optional system reactions like power reduction may become active. See also escalation management standstill.

## NOTICE

For the warnings based on crystallization, it’s generally no override possible!

Crystallization escalation steps:

Crystallization Detection	Description	Standstill Lamp (flashing speed)	Warning Lamp (behavior)	Buzzer	System Reaction (EU)	
		Symbol	Symbol		Operator Actions	
0	Normal operation	No crystalli- zation detected	-	-		no derating
			-	-		DPF regeneration
1	Crystallization detected Standstill required	Standstill required	(slow)	(solid on)		no derating
						carry out the override
2	Crystallization detected Warning Level	Standstill required	(slow)	(blinking)		derating step 1 active
						clean the def tank
3	Crystallization detected Shut Off Level	Service Tool required for standstill	(very fast)	(blinking)		derating step 2 active
						call for service

## DPF-SYSTEM (EU)

The DPF system is a closed soot filter system that accumulates the soot load during operation time of the machine. The filter regeneration is a continuous process (CRT) starting as soon as the necessary conditions at the inlet of the system are reached. These conditions are mainly exhaust temperatures and NOx / Soot-ratio.

The filter load is permanently monitored.

If the regeneration process is not possible for any reason the system triggers additional actions to start the regeneration.

An operator response is required only if these actions are not successful.

### NOTICE

**For the warnings based on DPF soot load, it's generally no override possible!**

DPF Regeneration strategy:

Crystallization Detection		Description	Standstill Lamp (flashing speed)	Warning Lamp (behavior)	Buzzer	System Reaction (EU)
			Symbol	Symbol		Operator Actions
0	Normal operation	No need for regeneration	-	-		no derating
			-	-		-
1	Heat Mode 1 requested	Heat Mode 1 requested	-	-		no derating
			-	-		-
2	Heat Mode 2 requested	Heat Mode 2 requested	-	-		no derating
			-	-		-
3	Standstill required	Standstill required	(slow)	-		no derating
				-		carry out the DPF regeneration
4	Warning Level	Standstill required	(slow)	(solid on)		derating step 1 active
						carry out the DPF regeneration (if necessary) + override
5	Shut Off Level	Service Tool required for standstill	(very fast)	(blinking)		derating step 2 active
						carry out the override + call for service
6	Remove Filter	DPF removal required. No standstill allowed	(very fast)	(blinking)		derating step 2 active
						carry out the override + call for service

### NOTICE

**For the warnings based on DPF soot load, it's generally no override possible!**

## EPA Legislation

For EPA applications a two stage inducement system is used. As soon as a relevant error is detected the operator is informed with an EAT related warning message.

- Derating Step 1 (EPA)**  
 This warning is followed by a low-level inducement (derating step 1), which reduces the available engine torque by 25 % in the whole operating range of the engine. The torque reduction becomes active with a rate of 10 % per minute.
- Derating Step 2 (EPA)**  
 If the error remains active a final inducement (derating step 2) becomes active. The final inducement is a forced low idle operation and will be announced by warning messages 10 minutes prior to activation. The torque reduction becomes active with a ramp of 10% per minute. The engine

speed reduction becomes active with 360 rpm per minute.

- **Inducement Override (EPA)**

During derating step 1 an override is possible. The override functionality can be requested one time during each period that the operator inducement system is active. Each override activation time is limited to 30 minutes.

The restored operation can be activated by an override command or by Customer Service. The system reacts on a rising edge of the input and starts the time counter. If the engine is shut off during an override period, the remaining time will be stored and can be used after restarting the engine. During final inducement (derating step 2) an override or restore functionality is not allowed. Due to previous warnings the operator must be aware of the impending circumstance.

## SCR-SYSTEM (EPA)

### DEF-Level Monitoring (EPA)

If no DEF additive is available in the DEF tank, the emission requirements cannot be fulfilled and therefore an inducement must be activated.

Three error messages are available representing the monitoring steps with active engine limitations.

## NOTICE

The “override” function is possible in the EPA variant only by Step 1. In case of active “override” and transition from Step 1 to the Step 2, the “override” will be interrupted!











- **Repeated Occurrence (EPA)**

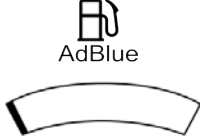



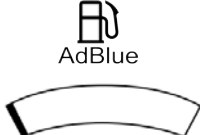



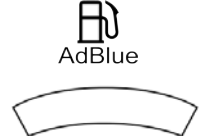



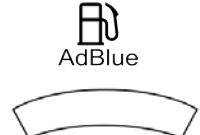



Time counters for activating derating step 1 and 2 will be frozen after healing or resetting an error. But also the timer for inducement override will be frozen. If an error of the group quality or tampering reoccurs within a period of 40 operating hours, the counters will continue with the frozen value. If derating step 2 was already active when the error was healed, it will become active again after 30 minutes for Quality and Tampering. The inducement level 30 minutes before severe inducement becomes active.

## NOTICE

The override of the errors which belong to the “Level” is possible considering above mentioned limitations.

DEF level monitoring escalation steps:

Level	Level indicator	DEF Lamp (flashing speed)	Warning Lamp (behavior)	Buzzer	System Reaction (EU)
		Symbol	Symbol		Operator Actions
>15%	 AdBlue 	-	-		-
		-	-		-
<15%	 AdBlue 	(solid on)	-		-
		Level < 15%	-		fill the def tank
<10%	 AdBlue 	(slow)	-		-
		 Level < 10%	-		fill the def tank

Level	Level indicator	DEF Lamp (flashing speed)	Warning Lamp (behavior)	Buzzer	System Reaction (EU)
		Symbol	Symbol		Operator Actions
<5%		(flashing)	(solid on)		-
					refill the def tank
10 min after level < 5%		(medium)	(solid on)		derating step 1 active
					carry out the override + refill the def tank
15 min after level < 5%		(fast)	(blinking)		derating step 1 active
					carry out the override + refill the def tank
20 min after level < 5%		(fast)	(blinking)		derating step 2 active
					call for service

The machine is fully restored to normal functionality and operation when a tank fill is performed and indicated. A tank fill is assumed when the level

exceeds the Reduction level 1 trigger level. If the filled DEF level does not exceed the initial warning level (<10%), the operator warning system remains active.

### Group DEF Quality (EPA)






If the DEF quality requirements, or too high NOx emissions are observed, or a system error causes not sufficient DEF injection, then the engine exhaust emissions cannot be observed.












The DEF Quality monitoring offers four escalation steps. A first warning is displayed as soon as an error is detected.

## NOTICE

The override of the errors which belong to the “DEF Quality” is possible considering above mentioned limitations.

DEF Quality escalation steps:

DEF Quality	DEF Lamp (flashing speed)	Warning Lamp (behavior)	Buzzer	System Reaction (EU)
	Symbol	Symbol		Operator Actions
Normal	-	-		-
	-	-		-
Too low	(solid on)	(solid on)		-
				-
Too low inducement Pretrigger 1	(solid on)	(solid on)		no derating active 3 h 15 min after detection

DEF Quality	DEF Lamp (flashing speed)	Warning Lamp (behavior)	Buzzer	System Reaction (EU)
	Symbol	Symbol		Operator Actions
	 restriction			carry out the override + call for service
Too low	(solid on)	(solid on)		derating step 1 active 3 h 25 min after detection
	 restriction			carry out the override + call for service
Too low inducement Pretrigger 2	(solid on)	(blinking)		derating step 1 active 3 h 45 min after detection
	 restriction			carry out the override + call for service
Too low	(solid on)	(blinking)		derating step 2 active 3 h 55 min after detection
	 restriction			call for service

The SCR-system could be damaged if DEF not according to specification is used in the system.

Additive quality complying with ISO 22241 must be used.

Dilution of the DEF with water will lead to deteriorated NOX reduction and clogging of the catalyst with resulting damage to the SCR-system.

Misfilling with diesel will lead to injection of diesel together with additive into the catalyst with very high combustion temperatures as a result that will damage the catalyst.

### Group Anti Tampering (EPA)

Monitoring of selected system failures is required because they may be attributed to tampering.

The operator information shall include specific information about which part of the EXHAUST GAS AFTERTREATMENT SYSTEM (DOC/DPF +SCR) is exposed to tampering, so that possible reparation of the system is facilitated.

The Anti-Tampering monitoring offers four escalation steps. A first warning is displayed as soon as a tampering is detected.

















Out-of specification additive must be detected as soon as possible, maximally within 30 minutes. As soon as poor quality additive is detected a warning will be activated. The sooner the operator is notified, the better the chance to easily remedy the problem.

The warnings regarding a low Efficiency Rate of the SCR system are sent in case that the low efficiency is detected after refilling the DEF tank (Reducing agent not acc. ISO 22241-1).

## NOTICE

The override of the errors which belong to the "Tampering" is possible considering above mentioned limitations.

Anti Tampering escalation steps:

DEF Quality	DEF Lamp (flashing speed)	Warning Lamp (behavior)	Buzzer	System Reaction (EU)
	Symbol	Symbol		Operator Actions
Normal	-	-		-
	-	-		-
Failure detected	(solid on)	(solid on)		-
				-
Failure detected inducement Pretrigger 1	(solid on)	(solid on)		no derating active 3 h 15 min after detection
	 restriction			carry out the override + call for service
Failure detected	(solid on)	(solid on)		derating step 1 active 3h25min after detection
	 restriction			carry out the override + call for service
Failure detected inducement Pretrigger 2	(solid on)	(blinking)		derating step 1 active 3h45min after detection
	 restriction			carry out the override + call for service
Failure detected	(solid on)	(blinking)		derating step 2 active 3h55min after detection
	 restriction			call for service

**Group Hardware Failure (EPA)**



Hardware failures are errors of the EAT components, e.g. defects of the urea pump.

In case of Hardware failure the Urea Warning Lamp and the general error lamp are permanently active.

**NOTICE**

**For the errors in the group “Hardware”, it’s generally no override possible!**

Hardware Failure escalation steps:

DEF Quality	DEF Lamp (flashing speed)	Warning Lamp (behavior)	Buzzer	System Reaction (EU)
	Symbol	Symbol		Operator Actions
Normal	-	-		-
	-	-		-
Failure detected Inducement pretrigger	(solid on)	(blinking)		no derating

DEF Quality	DEF Lamp (flashing speed)	Warning Lamp (behavior)	Buzzer	System Reaction (EU)
	Symbol	Symbol		Operator Actions
				call for service
Failure detected	(solid on)	(blinking)		derating step 2 active 10 min after detection
				call for service

### Crystallization Detection (EPA)

The SCR system is monitored for crystallization.

If crystallization is detected, the system can request a standstill as countermeasure.

If the operator ignores the standstill request, a specific error message will be created and optional system reactions like power reduction may become active. See also escalation management standstill.

### NOTICE

For the warnings based on crystallization, it's generally no override possible!

Crystallization escalation steps:

Crystallization Detection		Description	Standstill Lamp (flashing speed)	Warning Lamp (behavior)	Buzzer	System Reaction (EU)
			Symbol	Symbol		Operator Actions
0	Normal operation	No crystallization detected	-	-		no derating
			-	-		DPF regeneration
1	Crystallization detected Standstill required	Standstill required	(slow)	(solid on)		no derating
				-		carry out the override
2	Crystallization detected Warning Level	Standstill required	(slow)	(blinking)		derating step 1 active
						clean the def tank
3	Crystallization detected Shut Off Level	Service Tool required for standstill	(very fast)	(blinking)		derating step 2 active
						call for service

### DPF-SYSTEM (EPA)

The DPF system is a closed soot filter system that accumulates the soot load during operation time of the machine. The filter regeneration is a continuous process (CRT) starting as soon as the necessary conditions at the inlet of the system are reached. These conditions are mainly exhaust temperatures and NOx / Soot-ratio.

The filter load is permanently monitored.















If the regeneration process is not possible for any reason the system triggers additional actions to start the regeneration.

An operator response is required only if these actions are not successful.

**NOTICE**

DPF Regeneration strategy:

For the warnings based on DPF soot load, it's generally no override possible!

DPF Regeneration strategy Soot level		Description	Standstill Lamp (flashing speed)	Warning Lamp (behavior)	Buzzer	System Reaction (EU)
			Symbol	Symbol		Operator Actions
0	Normal operation	No need for regeneration	-	-		no derating
			-	-		-
1	Heat Mode 1 requested	Heat Mode 1 requested	-	-		no derating
			-	-		-
2	Heat Mode 2 requested	Heat Mode 2 requested	-	-		no derating
			-	-		-
3	Standstill required	Standstill required	(slow)	-		no derating
				-		carry out the DPF regeneration
4	Warning Level	Standstill required	(very fast)	(solid on)		derating step 1 active
						carry out the DPF regeneration (if necessary) + override
5	Shut Off Level	Service Tool required for standstill	(very fast)	(blinking)		derating step 2 active
						carry out the override + call for service
6	Remove Filter	DPF removal required. No standstill allowed	(very fast)	(blinking)		derating step 2 active
						carry out the override + call for service

**NOTICE**

For the warnings based on DPF soot load, it's generally no override possible!

## 2.4. COMPONENTS

### 2.4.1 CONTROLS

#### Driver's cab



## Overview

1. Operator's seat.
2. Seat left armrest.
3. Left armrest button console.
4. Left joystick.
5. Service brake pedal and inching control.
6. Adjustable steering column lever.
7. Safety buttons and switches.
8. Control lever for lights, horn, indicator lights and wipers.
9. Steering wheel.
10. Ignition lock.
11. "HMI" display (man-machine interface).
12. Forward / neutral / reverse direction selector.
13. Accelerator pedal.
14. "Emergency stop" button.
15. Right joystick.
16. "HMI" information screen navigator (man-machine interface).
17. Right armrest button console.
18. Seat right armrest.

## 2.4.2 PEDALS AND DIAGNOSIS SOCKETS

### SERVICE BRAKE PEDAL

The pedal (1) acts on the front and rear wheels and allows you to slow down and block the telescopic handler.

The brake pedal (1) in the first 20 mm of travel works as an Inching pedal allowing for precise and slow movements, in the remaining stroke it produces the braking effect.

### ACCELERATOR PEDAL

Pedal (2) that allows you to vary the speed of the telescopic handler by acting on the number of revolutions made by the heat engine.

### DIAGNOSIS SOCKETS

Remove the cover (3) to access the diagnostics sockets (A) and (B):

1. Machine electronics
2. Machine and engine electronics

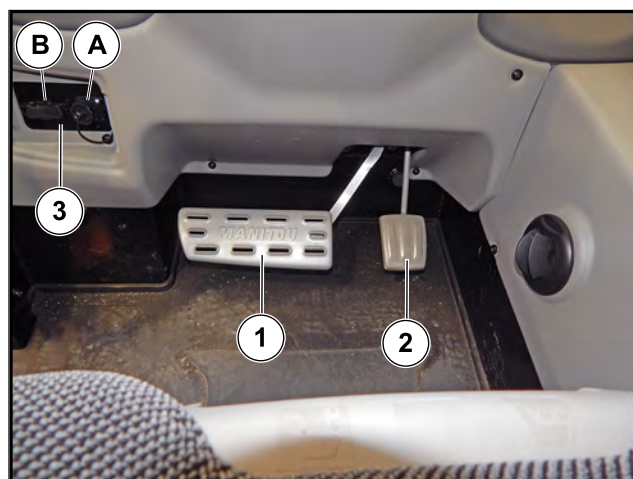


Figure 92: Pedals and diagnosis sockets

## 2.4.3 ADJUSTABLE STEERING COLUMN LEVER

### Adjusting the steering wheel

The lever (1) allows you to adjust the steering wheel to suit the operator.

Push down the lever (1) to loosen the grip of the steering wheel lock:

- Adjust the height.
- Adjust the telescopic adjustment.

Pull the lever (1) up to lock the steering wheel.

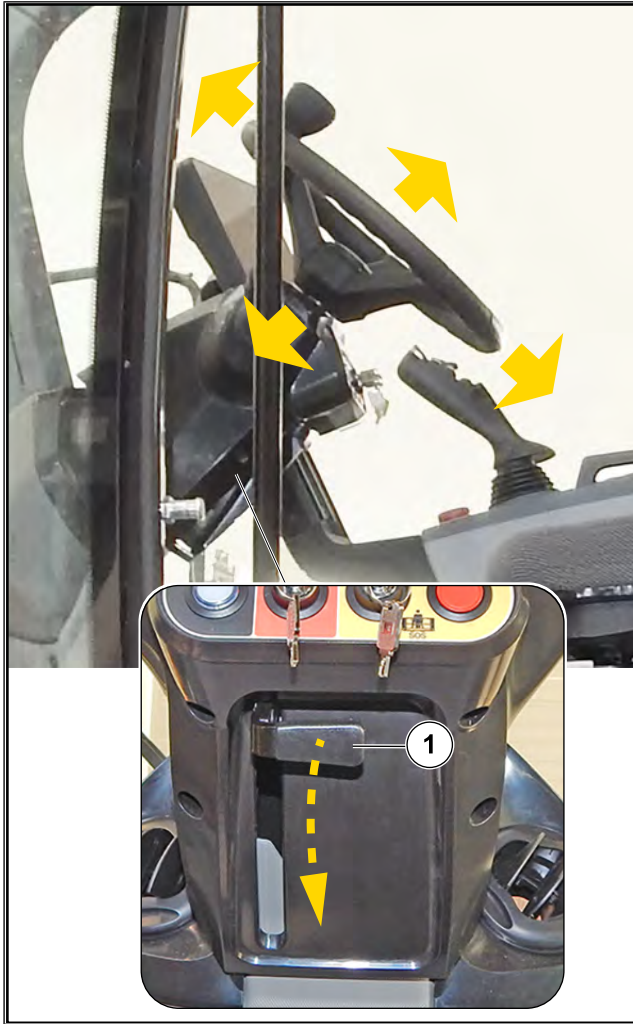


Figure 93: Adjusting the steering wheel

### 2.4.4 CONTROL LEVER FOR LIGHTS, HORN, INDICATOR LIGHTS AND WIPERS

The switch controls:

- Turning on the lights.
- Indicators.
- The acoustic signal.
- Wipers.

To control the features move or press (horn) the lever or rotate the 3 selectors.

When some features are enabled, warning lights on the display light up.

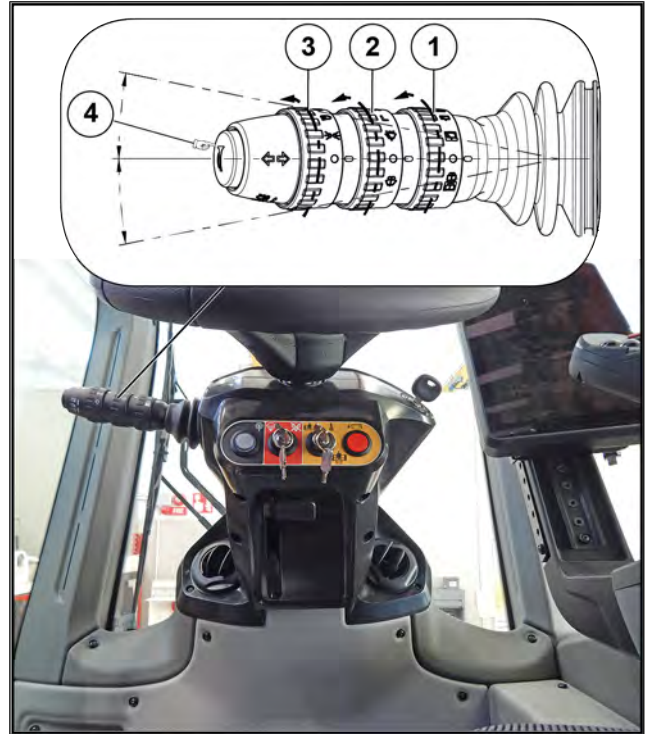


Figure 94: Control lever for lights, horn, indicator lights and wipers

### Symbols overview

1 - REAR AND UPPER WIPER CONTROL RING SELECTOR	
	Top and rear control (side if present)
	Rear control
	Top control
	Off control
	Upper and rear window washer control (side if present)

Table 171. Front wiper control dial selector

2 - FRONT WIPER CONTROL RING SELECTOR	
	Second speed
	First speed
	Intermittent speed



2 - FRONT WIPER CONTROL RING SELECTOR	
	Off control
	Window washer control

Table 172. Front wiper control dial selector









3 - LIGHTS CONTROL RING SELECTOR	
	Rear fog lamp
	Dipped beam
	Sidelights
	Off control

Table 173. Front wiper control dial selector

4 - LEVER CONTROLS	
	Horn (press)
	Indicator lights <ul style="list-style-type: none"> <li>• Lever up: Turn right</li> <li>• Lever down: Turn left</li> </ul>
	High beams on <ul style="list-style-type: none"> <li>• Lever forward</li> </ul>
	High beam flashing <ul style="list-style-type: none"> <li>• Lever back</li> </ul>

### 2.4.5 USB PORT

The USB port (1) equipped with “Plug and Play” support is a cable connection for communication and power supply between electronic devices.



Figure 95: USB Port

### 2.4.6 SUNSHADE

The sunshade (1) can completely obscure the top of the cabin window (2) and drop onto a part of the front window (3).

Move the sunshade (1) at the top of the window (2) forwards or backwards and release it in the desired position.

Move the sunshade (1) as far as possible from the top of the window (2) until it slides to obscure the front windshield (3) and fasten it to the fasteners (4) positioned on cabin uprights.

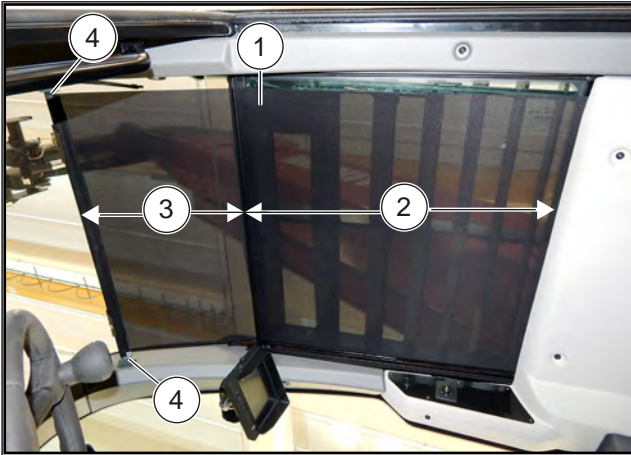


Figure 96: Sunshade

## ▲ DANGER

### Risk of injury to the operator

When returning to its position, the sunshade could suddenly snap backwards with the risk of breaking or hitting the operator.

When unhooking the sunshade (1) from the front window (3), do not release it, but hold onto it until it is completely retracted.

### 2.4.7 DISPLAY HEIGHT ADJUSTMENT KNOB

To move the Display to the desired height, pull and hold the knob (1) located on the side of the Display (2).

To lock the position of the Display, release the knob (1).



Figure 97: Display height adjustment knob

### 2.4.8 CABIN ACCESSORIES

The following standard accessories are available in the cabin of all machine models:

- 12V SOCKET (1)
- BEVERAGE HOLDER (2)
- MOBILE PHONE HOLDER (3)



Figure 98: Cabin accessories

### 2.4.9 CEILING LIGHT AND REAR WINDOW OPENING LEVER

#### CEILING LAMP

The switch (1) is incorporated in the ceiling light (2).

The switch (1) has two positions:

- Continuous lighting.
- Shutdown.

**REAR WINDOW OPENING LEVER**

To open the rear window (3), turn the lever (4) clockwise and push the window (3).

**Emergency exit**

If it is impossible to get out of the cabin door or the front windshield opening, use the rear window (3) as an emergency exit.

Remove the split pin (4A) to fully open the rear window (3).

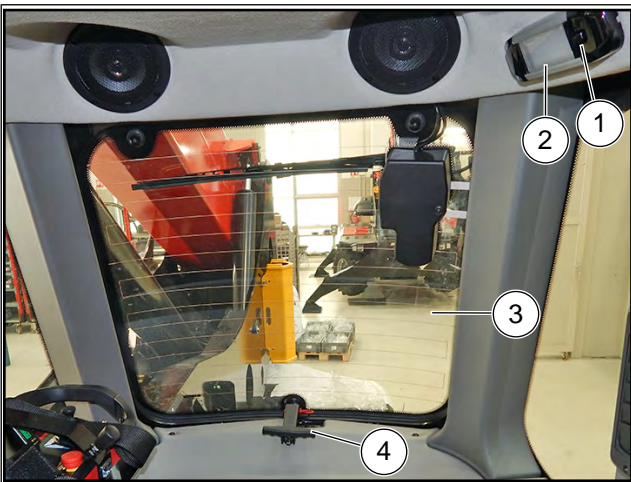


Figure 99: Ceiling light and rear window opening lever

**2.4.10 OPENING THE DOOR AND DOOR WINDOW**

**DOOR WINDOW RELEASE LEVER**

To open the door window, grasp the bar (2) and push the lever (1) back.

**DOOR OPENING HANDLE**

To open the door, grasp the bar (3) and press the handle (3A).



Figure 100: Opening the door and door window

**2.4.11 DOOR WINDOW RELEASE LEVER FROM INSIDE CABIN**

To unlock the door window, operate the lever (1).

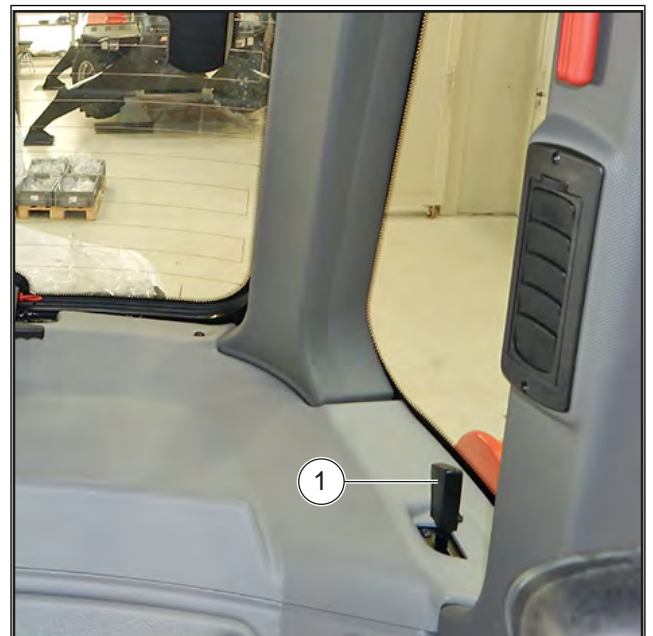


Figure 101: Door window release lever from inside cabin

**2.4.12 DOOR WINDOW RELEASE LEVER FROM OUTSIDE CABIN**

The lever (1) is located under the cabin. To unlock the door window, grasp the lever (1) and push it back.



Figure 102: Door window release lever from outside cabin

### 2.4.13 AIR DIFFUSERS

#### AIR DIFFUSERS FOR DEMISTING SIDE AND FRONT WINDOWS

For optimum efficiency, before turning on the air diffusers (1) for demisting the windows, close the heating air vents (2).

#### HEATING AIR VENTS

The heating vents (2) allow for distributing ventilated air inside the cabin, on the upper (2A), rear (2B) and lower (2C) parts.



Figure 103: Demisting diffusers and heating air vents

### 2.4.14 REGISTRATION PLATE

The vehicle is designed for the posting of the registration plate (1) for road traffic and its lighting (2).



*The registration plate must comply with mandatory regulations in the country where the vehicle is registered.*

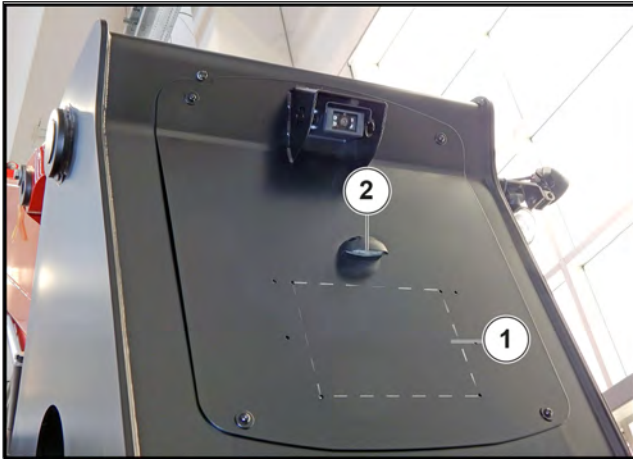


Figure 104: License plate and plate lighting

### 2.4.15 HEADLIGHTS

1. Front left turn signal light (amber).
2. Front left low beam light (white).
3. Front left high beam light (white).
4. Front left parking light (white) with daylight feature.
5. Front right turn signal light (white).
6. Front right low beam light (white).
7. Front right high beam light (white).
8. Front right parking light (white) with daylight feature.

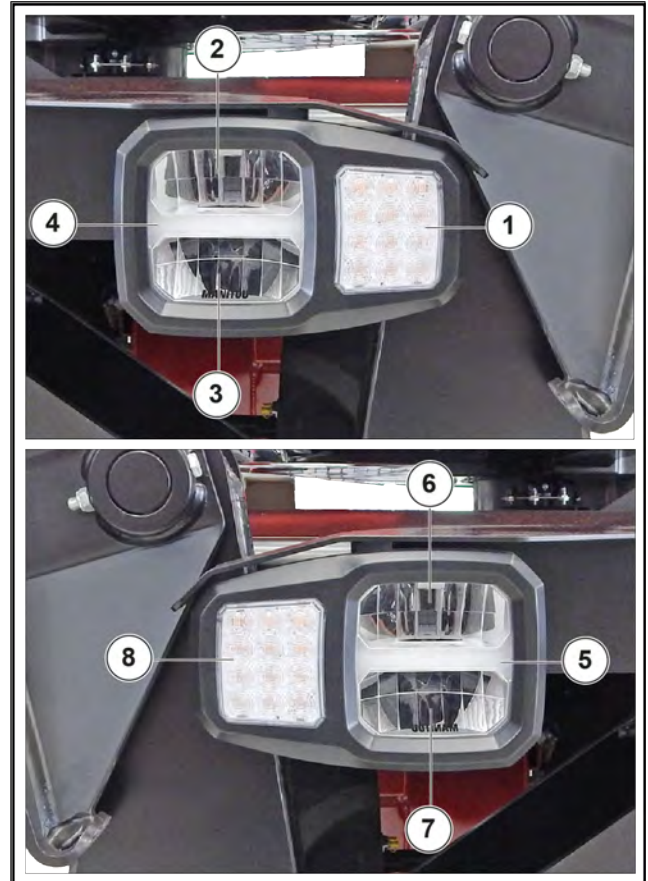


Figure 105: Headlights

### 2.4.16 TAIL LIGHTS

1. Rear left turn signal light (amber).
2. Rear left tail light and brake light (red).
3. Reflector (red).
4. Rear fog light (red).
5. Rear reversing light (white).
6. Reflector (red).
7. Rear left tail light and brake light (red).
8. Rear right turn signal light (amber).

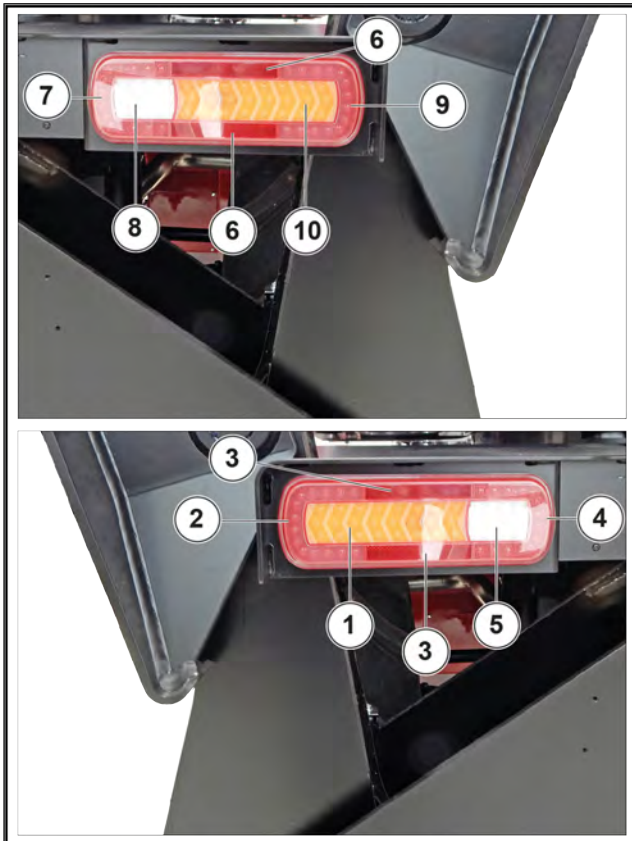


Figure 106: Tail lights

## 2.4.17 BEACON AND SIGNAL HEADLIGHTS

### AMBER LED BEACON

The beacon (1) must be turned on every time the vehicle is used to indicate that it is in operation.

The beacon (1) is turned on from the cabin by pressing the button on the "HMI" navigator.

### RED LED HEADLIGHT

**⚠ DANGER**

#### Risk of vehicle overturning

When disabling the vehicle's Manitou Safety System (MSS) there is a risk of the vehicle turning over.

The headlight (2) turns on steadily together with an acoustic signal to indicate that the vehicle's Manitou Safety System (MSS) has been temporarily disabled by the operator, and flashes if the machine reaches 100% load status.

### FLASHING WHITE LED HEADLIGHT

The headlight (3) on (slow double white flash) warns and indicates that the remote control feature is enabled and that the telescopic handler is being remotely controlled.

The headlight (3) off, indicates that the remote control feature is not active.



Figure 107: Headlights and beacon

The beacon (1) and the headlights (2) and (3) can be tilted to reduce, when necessary, the overall space taken up by the telescopic handler.

The beacon (1) and the headlights (2) and (3) can also be disassembled to prevent theft:

- Unscrew the nut (A) and remove the beacon or the headlights.
- Protect the base with the cover (B).

## 2.4.18 BATTERY DISCONNECT SWITCH

It allows for quickly isolating the battery, for example in case of intervention on the electric circuit or in case of welding.

1. Switch off the telehandler.
2. Wait at least 30 seconds.
3. Operate the switch (1).



*This waiting time is required for the diesel emission fluid (DEF) system.*

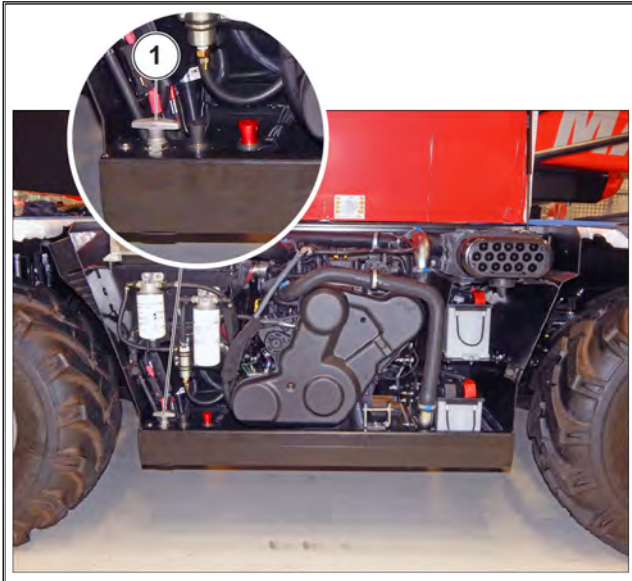


Figure 108: Battery disconnect switch

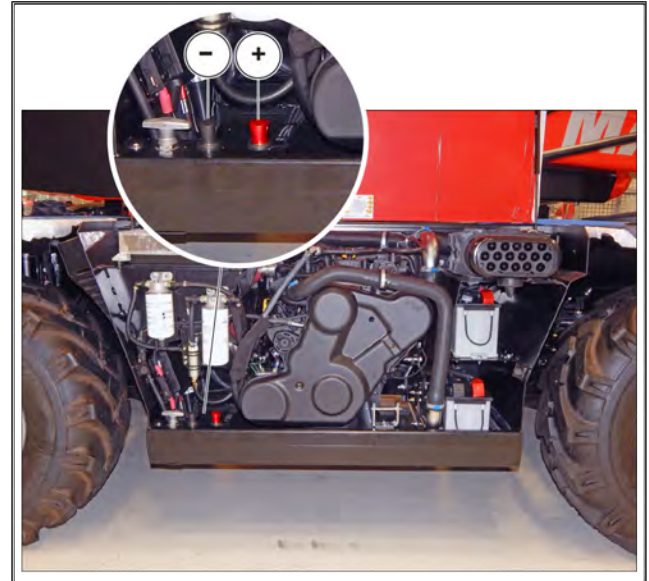


Figure 109: Emergency starting (MRT 2145 – 2545)

### 2.4.19 EMERGENCY STARTING

If the engine does not start due to low battery voltage, it is possible to start the engine via an external device connected to the battery poles (+, -), marked with black (-) and red (+) to indicate polarity.

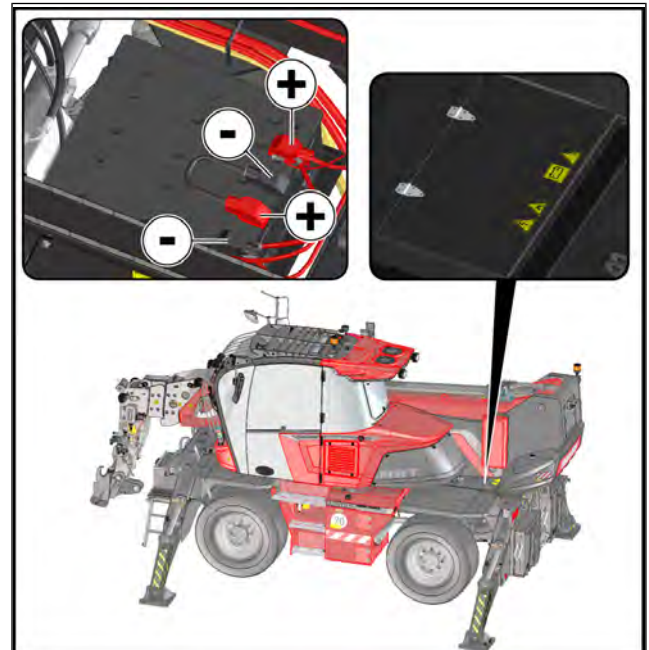


Figure 110: Emergency starting (MRT 1645 – 1845)

### 2.4.20 BOOM SAFETY WEDGE

 Only use the safety wedge (1) supplied with the telehandler.

** DANGER**

#### Risk of crushing

During installation of the safety wedge, do not stand under the telescopic boom.

The telescopic handler is equipped with a safety wedge (1) which prevents accidental descent of the

telescopic boom during maintenance operations of the same or in the areas below it. The boom safety wedge must be installed on the rod of the handler cylinder.

When not in use, the safety wedge (1) is positioned on the telehandler turret through its fixings (1a).

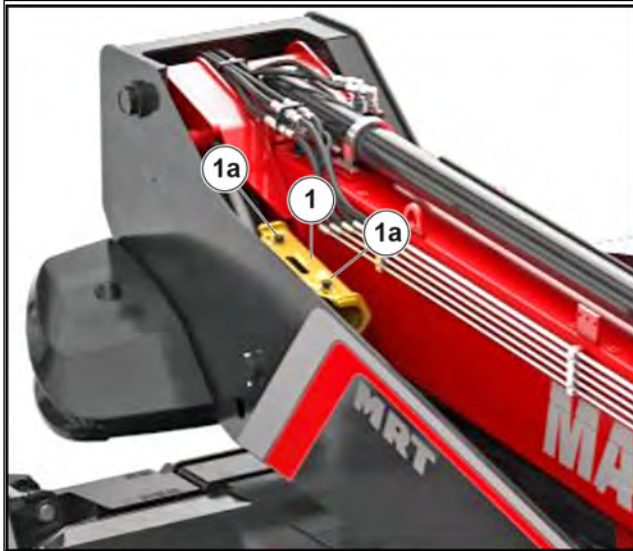


Figure 111: Boom safety wedge

## 2.5. OPERATOR AREA

### 2.5.1 GETTING IN AND OUT OF THE VEHICLE

#### ⚠ WARNING

The vehicle is equipped with two ladders (front and rear) that allow access to the walkable surface above the vehicle's undercarriage. The latter must only be used during maintenance operations to access the walkable surface.

It is not allowed to use the front or rear ladder to access the vehicle cabin.

#### ⚠ WARNING

To get in and out of the vehicle, use the access ladder located on the left side of the vehicle (fuel tank area).

The telehandler is equipped with access steps (1) and two handles (2) which are located inside the cabin to facilitate the operator's entry and exit from it.




Figure 112: Getting in and out of the vehicle

### 2.5.2 A - DRIVER'S SEAT (STANDARD)

Designed for maximum comfort, this seat can be adjusted as follows.

Sit in the seat properly.

1. Forward-backward adjustment of the seat, in relation to the control joysticks.  
Pull the lever (1) up.  
Move the seat forward or backward to the desired position, depending on the armrests.  
Release the lever and make sure it returns to the blocked position.
2. Forward-backward adjustment of the seat.  
Pull the handle (2) upwards.  
Move the seat forwards or backwards to the desired position.  
Release the lever and make sure it returns to the blocked position.
3. Tilting seat backrest.  
Pull the lever up (3) and tilt the seat to the desired position.  
Release the lever and make sure it returns to the blocked position.

 *If the backrest is not supported during adjustment, it will tilt all the way forward.*

4. Weight-dependent seat suspension adjustment.  
Depending on the weight of the operator, the excursion of the seat suspension can be varied. To do this, use the crank (4) to set the desired value.  
The weight value is displayed in the indicator alongside (4a) the crank (4).  
Release the crank and make sure it returns to the blocked position.
5. Adjusting the seat cushion depth.  
Pull the handle (5) upwards.  
Move the seat to the desired position.  
Release the lever and make sure it returns to the blocked position
6. Adjusting seat cushion forward tilt.  
Pull the handle (6) upwards.  
Move the seat to the desired position.  
Release the lever and make sure it returns to the blocked position
7. Lumbar adjustment of the seat backrest.  
Turn the knob (7) to adjust the lumbar area of the backrest.



Figure 113: Driver's seat (standard)


### 2.5.3 B - PNEUMATIC SEAT FOR DRIVER (OPTIONAL)

Designed for maximum comfort, this seat can be adjusted as follows.

Sit in the seat properly.

Switch on the electrical contact of the telehandler.

1. Forward-backward adjustment of the seat, in relation to the control joysticks.  
Pull the lever (1) upwards.  
Move the seat forward or backwards to the desired position, depending on the armrests.  
Release the lever and make sure it returns to the blocked position.
2. Forward-backward adjustment of the seat.  
Pull the handle (2) upwards.  
Move the seat forwards or backwards to the desired position.  
Release the lever and make sure it returns to the blocked position.
3. Seat backrest tilting adjustment.  
Supporting the backrest, pull the lever upwards (3) and tilt the seat to the desired position.  
Release the lever and make sure it returns to the blocked position.

 *If the backrest is not supported during adjustment, it will tilt all the way forward.*

4. Height and weight adjustment:
  - Seat suspension adjustment according to the operator's weight.  
Pull the lever (4) once to self-adjust the seat suspension according to the weight of the operator.  
Release the lever (4).
  - Seat height adjustment.  
Keep the lever (4) pulled up or down to vary the seat height.  
Release the lever (4) at the desired height.
5. Blocking lever (5) for suspension adjustment.
6. Seat cushion depth adjustment.  
Pull the handle (6) upwards.  
Move the seat to the desired position.  
Release the lever and make sure it returns to the blocked position
7. Adjusting seat cushion forward tilt.  
Pull the handle (7) upwards.  
Move the seat to the desired position.  
Release the lever and make sure it returns to the blocked position.
8. Lumbar adjustment of the backrest.  
Press the switch (8) to adjust the lumbar support.  
Release the switch (8) in the desired position.
9. Blocking lever (9) for seat forward-backward adjustment.

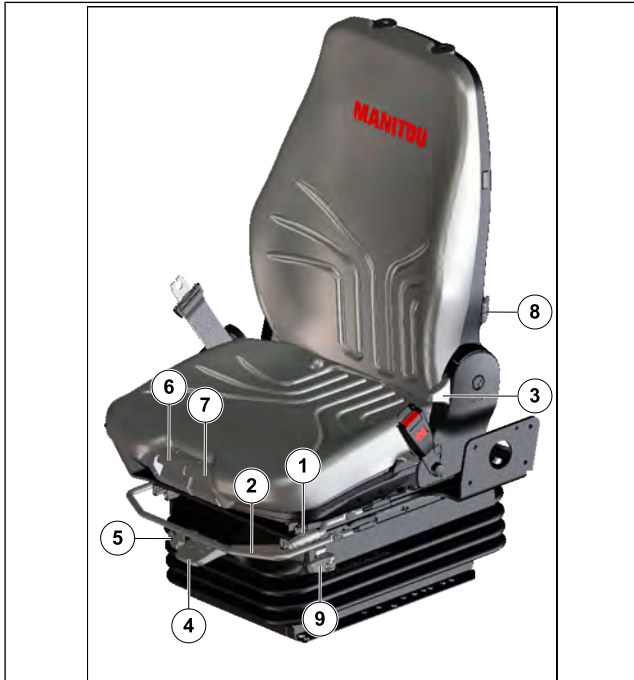


Figure 114: Pneumatic seat for driver (optional)


### 2.5.4 C - HEATED / VENTILATED DRIVER'S SEAT (OPTIONAL)

Designed for maximum comfort, this seat can be adjusted as follows.

Sit in the seat properly.

Switch on the electrical contact of the vehicle.

1. Forward-backward adjustment of the seat, in relation to the control joysticks.  
Pull the lever (1) up.  
Move the seat forward or backward to the desired position, depending on the armrests.  
Release the lever and make sure it returns to the blocked position.
2. Forward-backward adjustment of the seat.  
Pull the handle (2) upwards.  
Move the seat forwards or backwards to the desired position.  
Release the lever and make sure it returns to the blocked position.
3. Seat backrest tilting adjustment.  
Supporting the backrest, pull the lever upwards (3) and tilt the seat to the desired position.  
Release the lever and make sure it returns to the blocked position.

 *If the backrest is not supported during adjustment, it will tilt all the way forward.*

4. Height and weight adjustment:
  - Seat suspension adjustment according to the operator's weight.  
Pull the lever (4) once to self-adjust the seat suspension according to the weight of the operator.  
Release the lever (4).
  - Seat height adjustment.  
Keep the lever (4) pulled up or down to vary the seat height.  
Release the lever (4) at the desired height.
5. Blocking lever (5) for suspension adjustment.
6. Seat cushion depth adjustment.  
Pull the handle (6) upwards.  
Move the seat to the desired position.  
Release the lever and make sure it returns to the blocked position
7. Tilting seat cushion forward.  
Pull the handle (7) upwards.  
Move the seat to the desired position.  
Release the lever and make sure it returns to the blocked position.
8. Lumbar adjustment of the backrest.  
Press the switch (8) to adjust the lumbar support.  
Release the switch (8) in the desired position.
9. Blocking lever (9) for seat forward-backward adjustment.
10. Seat heating and seat ventilation switch.  
The seat ventilation system ensures that the seat surface remains dry. Moisture in the seat contact area will be removed. This ensures a comfortable, cool and clean sitting environment.

Use this switch to activate or deactivate seat heating and seat ventilation:

- 0 = Seat heating and seat ventilation OFF
- 1 = Seat heating ON (seat ventilation OFF)
- 2 = Seat ventilation ON (seat heating OFF)

11. Headrest extension.

The height of the headrest (11) can be adjusted by pulling it upwards (the grooves will snap into the joints) as far as the stop.

The headrest (11) can be removed by applying enough pressure to free it from the stop.

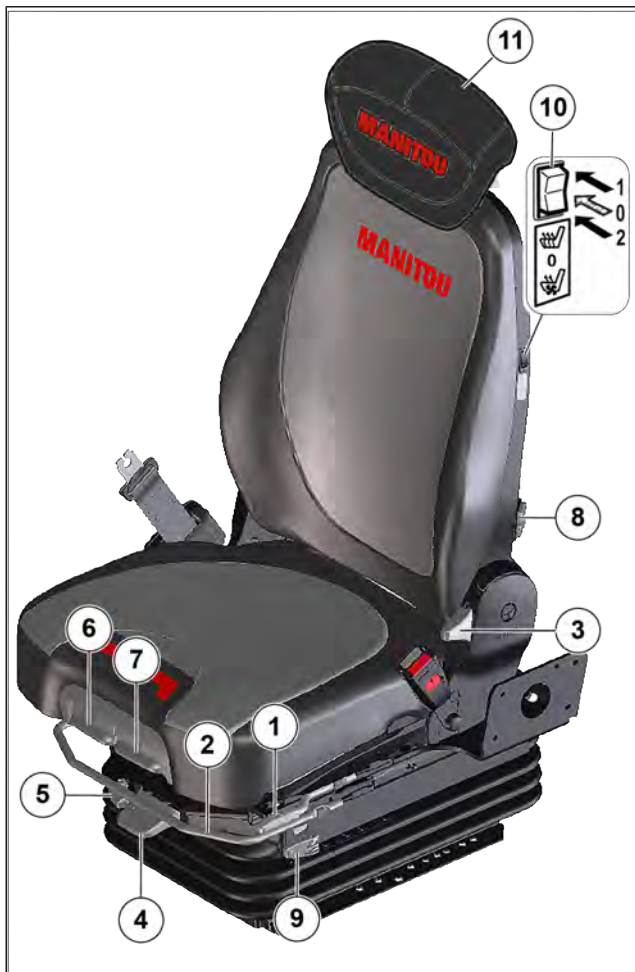


Figure 115: Heated/ventilated driver's seat (optional)

2.5.5 SEAT BELT

Sit in the seat properly.

- Make sure that the belt (1) is not twisted.
- Wear the belt at the level of the pelvis.
- Fasten the seat belt (1) and check that it is securely locked (2).
- Adjust the belt according to your body size, avoiding compressing the pelvis and without excessive play.



Never use the telehandler with a defective seat belt (fastening, locking, stitching, tearing, etc.). Repair or replace the seat belt immediately.

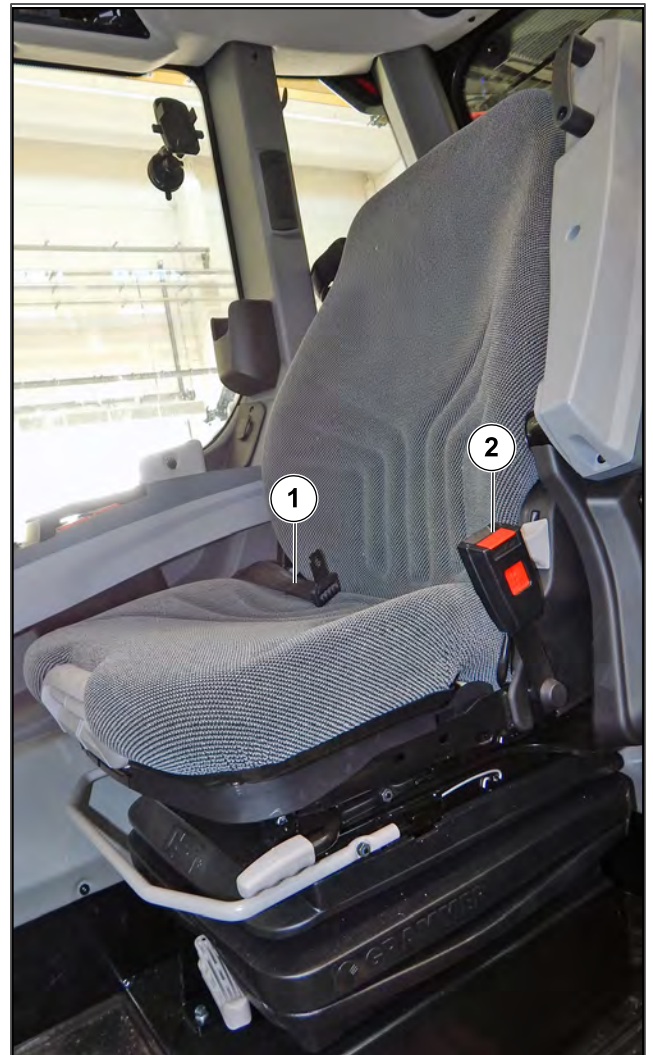


Figure 116: Safety belt

2.5.6 IGNITION SWITCH

The switch (1) has 4 positions and its features are:

- 0 : STOP heat engine.
- I : General electrical contact "+" (also activates the preheating device if installed).
- II : Not used.
- III : STARTING the heat engine and returning to position "I" after releasing the key (also deactivates the preheating device if installed).

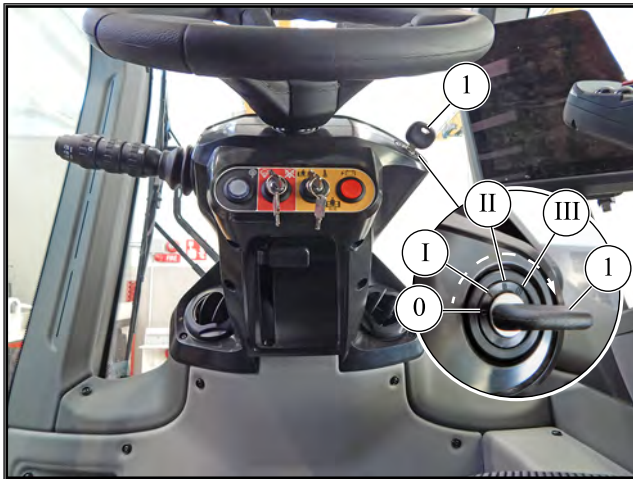


Figure 117: Ignition switch

### 2.5.7 "EASY MANAGER" ANTI-START SYSTEM (OPTIONAL)

#### "Easy MANAGER" identification keypad

It requires the creation of identification for the operator from the "EasyMANAGER" portal. For more information contact the dealer.

#### OPERATION

##### BY MEANS OF IDENTIFICATION CODE

- Insert the electrical contact on the vehicle, the LED (1) lights up.
- Enter the identification code and confirm it by pressing the (V) key.
- The LED (2) lights up green to confirm operator identification.
- Switch on the vehicle immediately, after this period, the identification is canceled and the LED (2) turns red.



*In the event of a typing error, the LED (2) lights up red, press the (X) key and wait 10 seconds before entering the correct identification code.*

##### BY MEANS OF IDENTIFICATION CARD

- Insert the electrical contact on the vehicle, the LED (1) lights up.
- Show the identification card, a beep confirms the reading of the card.
- The LED (2) lights up green to confirm operator identification.
- Switch on the vehicle immediately, after this period, the identification is canceled and the LED (2) turns red.

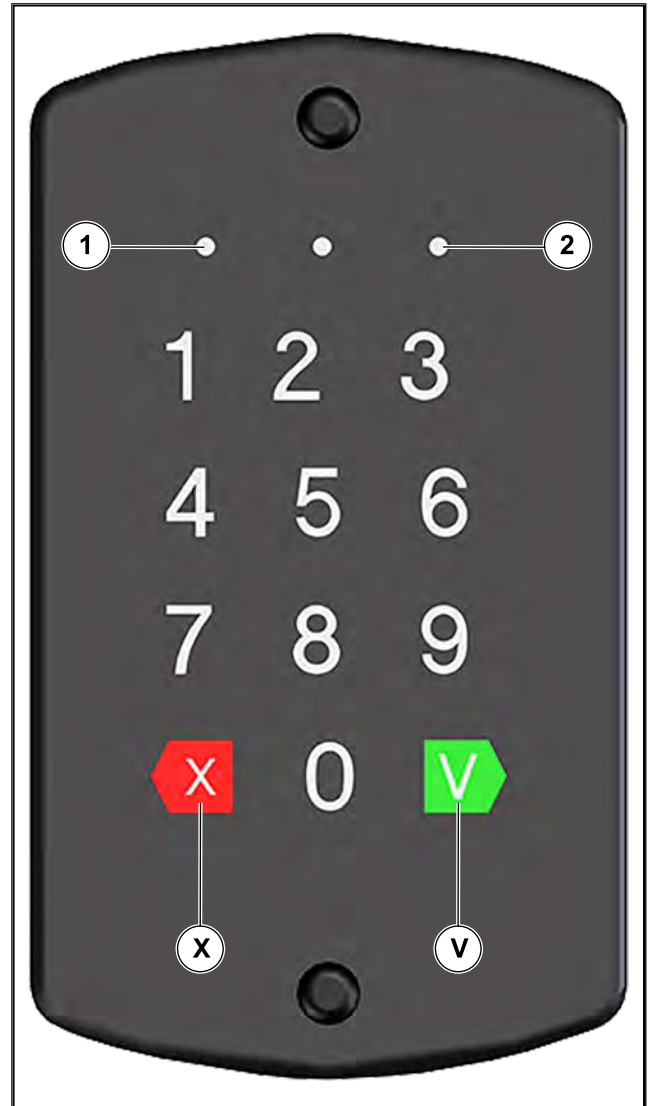


Figure 118: "Easy MANAGER" anti-start system

## 2.6. DISPLAY

### 2.6.1 DISPLAY CONTROL

#### INFORMATION SCREEN OF HMI NAVIGATOR

(human machine interface)



*The contents of the "SETTINGS" and "DIAGNOSTICS" menus vary according to the equipment of the vehicle.*

#### 1. ROTARY KNOB WITH CONFIRMATION BUTTON.

The knob rotates clockwise and counterclockwise.

Turn the knob to scroll the buttons on the pages and navigate within them (if possible), press the knob to confirm your preferences.

Turning the knob (1) activates the highlighting and moves it to elements on the page.

On each page, activation starts from the MENU button (bottom bar, left side).

By turning the knob (1) clockwise, the highlight will move to the shortcuts and then to the screen above.

By turning the knob (1) counterclockwise, the highlight will move to the top area and then to the bottom screen.

Once activated, section highlighting will start from the first element at the top / left of the selected area.

**2. SETTINGS PAGE**

Briefly press the button (2) to display the "SETTINGS" page.

Turn the knob (1) to navigate on the page and the sub-menus.

Press the knob (1) to confirm your preference.

**3. DIAGNOSTICS PAGE**

Briefly press the button (3) to display the "DIAGNOSTICS" page.

Turn the knob (1) to navigate the menu and sub-menus.

Press the knob (1) to confirm your preference.

**4. BACK BUTTON**

Briefly press the button (4) to return to the previous screen.























Figure 119: Display control

**2.6.2 DISPLAY ICONS**

Overview of symbols and features:

Table 174. Indicators

INDICATORS	
	Sidelights
	Dipped beam headlights
	Main beam headlights
	Rear fog lamp
	Indicator lights
	Telescopic handler door open
	Seat belt not fastened
	Engine coolant temperature

INDICATORS	
	Fuel Reserve (Fuel level less than 10% of tank capacity)
	Hydraulic oil temperature (Blue indicator on, the temperature is low: below 20°)
	Turret position aligned with the undercarriage (depending on machine model)
	Turret aligned with the forklift truck and turret rotation pin inserted. Turret rotation blocked. (Depending on Machine Model)
	Turret in front position (Depending on machine model)
	Turret in rear position: Reverse steering (Depending on machine model)
	Front wheel alignment
	Rear wheel alignment
	Front wheel drive (Driving on road)
	Opposite direction forward and backward wheel steer (Small turning radius)
	Front and rear wheel drive in the same direction (lateral movement)
	Rear axle block
	Low gear engaged (Depending on machine model)
	High gear engaged (Depending on machine model)
	Diesel exhaust fluid (DEF) tank level
	Emission-related malfunction of the exhaust after-treatment system or of the DEF supply
	Approval of regeneration of the DPF filter
	DPF filter regeneration required
	DPF filter regeneration disabled by the operator
	Active regeneration and high temperature of the exhaust gas










INDICATORS	
	Platform movement in operation
	Platform movement in operation
	Maximum moving speed adjustment
	Heat engine RPM adjustment
	Continuous optional (Oil flow % setting)
	Radio control (Optional)
	2nd optional in operation (Optional)
	3rd optional in operation (Optional)
	Maintenance interval

Table 175. Warning lights

















WARNING LIGHTS	
	Serious heat engine failure
	Heat engine malfunction
	Alternator excitation
	Heat engine oil pressure
	Engine air intake filter
	Transmission oil filter
	Hydraulic oil filter
	Parking brake on
	Low brake oil pressure
	Red warning light for disabling the load limiter
	DANGER! Red warning light for disabling the load limiter

Table 176. Icons

ICONS	
	Eco fuel mode (Lit blue or yellow in operation)
	Drive & Handling shift mode (Lit blue or yellow in operation)
	Eco mode Stop heat engine (Lit blue or yellow in operation)
	Eco fuel mode (Lit blue or yellow in operation)
	Drive & Handling shift mode (Lit blue or yellow in operation)

### 2.6.3 DISPLAY PAGES

The color screen display (1) shows and informs the operator about all the work phases of the telehandler.

Different control modes stored in the display memory (1) can be selected on touchscreen or via the “HMI” navigator (2) on the right armrest (3) in the cabin.



Figure 120: Display control mode

Upon startup, the HMI shows the Manitou startup animation for 10 seconds while waiting for the application to be ready.

The Manitou logo appears 1 second after the dashboard is activated.



Figure 121: HMI start

The fixed features of the HMI areas are:

- The information bar (1).
- The warning lights and indicators (2a), the load status bar (2b).
- Audio playback in progress (3).
- The button bar (4).
- The top (5) and bottom (6) may be different in relation to the activity shown.

Overview:

- Information bar area (1):  
it contains the outdoor temperature, configuration and time.
- Warning lights and indicators area (2a), the load status bar (2b):  
it contains the warning lights or indicators, the errors activated, the load status bar, the status of the selector that disables the anti-tipping system and the type of attachment connected.

- Load status bar (2b) indicates the percentage of load lifted with respect to the maximum load that can be lifted in those working conditions:
  - ◆ Green part: Safety Zone.
  - ◆ Yellow part: Alarm zone. Lifted load greater than 90% of the permissible load (external acoustic signal enabled).
  - ◆ Red part: Blocking zone. Lifted load greater than 100% of the permissible load (external horn active).
- Top (5):  
contains the main view and the bars of the selected page.
- Bottom (6):  
contains touch integration which causes changes at the top.
- Repetition area (3):  
multimedia or radio information.
- Button bar area (4):  
it contains the main menus of the HMI, man-machine interface.

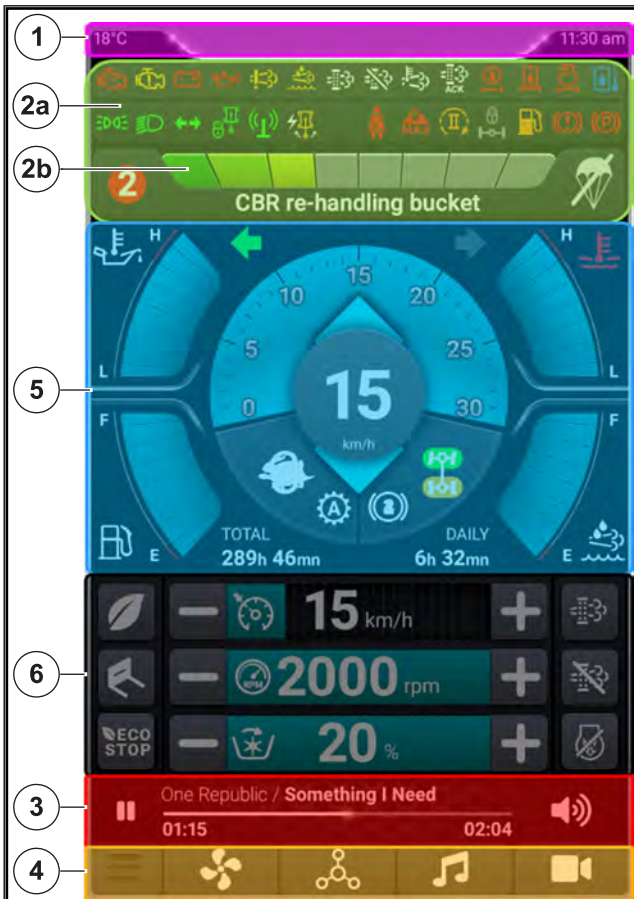


Figure 122: HMI area

### 2.6.4 BUTTON BAR

- MENU (Main Functions) (A)
- HEATING and AIR CONDITIONING (optional) (B)
- MULTIFUNCTION (C)
- FM RADIO / DAB / USB & PHONE MANAGEMENT (D)
- REAR CHAMBER (E)

Briefly press the button to access the content.

Select a button (B, C, D, E) of the bar (4), the button is highlighted and the content is opened at the bottom of the screen.

Select button (A) to open the drop-down menu on the left side of the screen (see MENU PAGE).

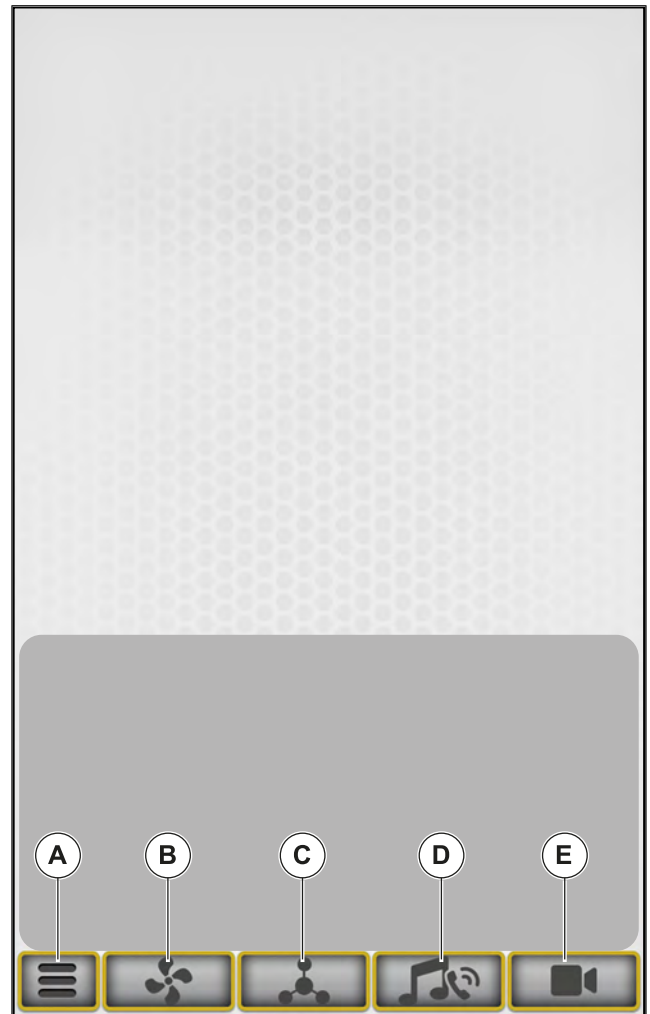


Figure 123: Button bar

### B - OPTIONAL HEATING AND AIR CONDITIONING BUTTON

Briefly press the button to access the cabin ventilation panel.

The panel can contain two configurations:

- Heating.
- Air conditioning (optional).

Briefly press the touch buttons to enable or disable the features.

Table 177. Overview buttons icons












Icon	Description
	Ventilation direction: <ul style="list-style-type: none"> <li>- Air vents</li> <li>- Glass demisting diffusers.</li> </ul>
	Air recirculation
	Max windshield defrost (Only with Air Conditioning)
	Air conditioning ON / OFF (Only with Air Conditioning)
	Automatic control (Only with Air Conditioning)
	Ventilation panel ON / OFF
	Rear window heater
	Exterior rear view mirror heater
	Foot mat heater
	Temperature regulation: + = Increase speed - = Decrease speed
	Fan speed adjustment: (10 speeds available) + = Increase speed - = Decrease speed








Figure 124: Heating and Air Conditioning button (Optional)



## C - MULTI-FEATURE BUTTON

Press the button briefly to access some features of the rotating telehandler.

Briefly press the controls to enable or disable the features.

Table 178. Icons overview

Icon	Description
	Work lights at the top of the telescopic boom (optional)
	Front cabin work lights (optional)
	Corner light (optional)
	Rear, roof and side wipers, intermittent activation
	Rear cabin work light

Icon	Description
	Request intermediate suspension height position (keep the button pressed)
	Suspension activation request (briefly press the button)

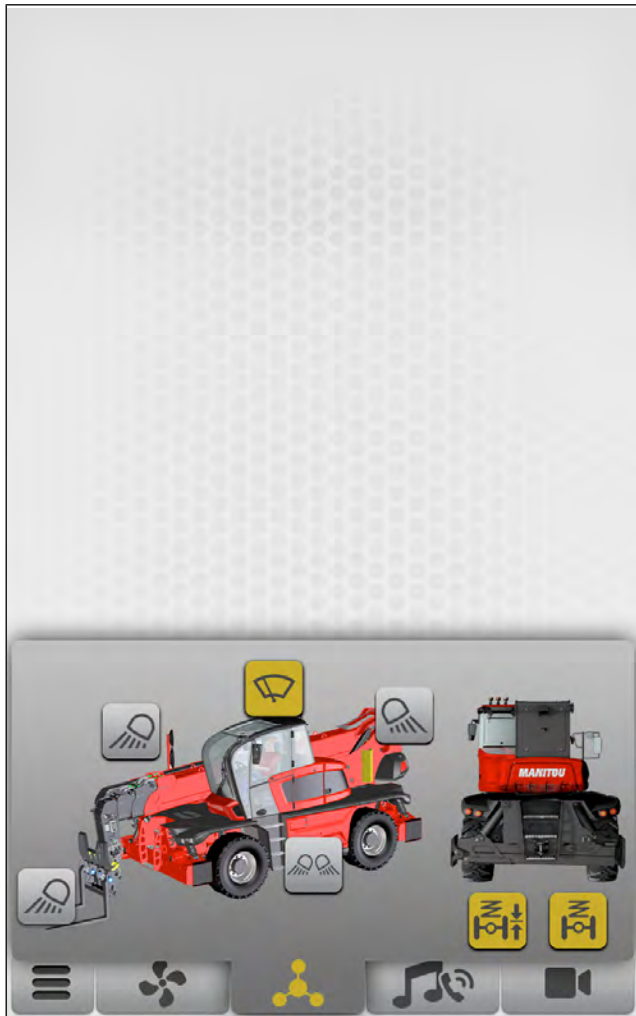


Figure 125: Multi-feature button

### D - FM RADIO / DAB / USB & PHONE MANAGEMENT

Briefly press the button to access the management screen of RADIO, USB, BLUETOOTH, TELEPHONE features. The button is highlighted.

Press the buttons briefly to enable the features. Selected buttons or enabled features are highlighted.



Figure 126: Radio management button

### E - REAR CAMERA

Briefly press the touch screen button to access the screen. The button is highlighted.

The camera shortcut can be shown at the operator's request or during reverse gear activation.

The camera shows the rear of the rotating telehandler.



Figure 127: Rear camera

## 2.6.5 MENU PAGES

Overview:

1. "DRIVE" PAGE
2. "WORKING" PAGE
3. "STABILITY" PAGE
4. "ADJUSTMENTS" PAGE
5. "DIAGNOSTICS" PAGE
6. "SETTINGS" PAGE
7. "RESOURCES" PAGE
8. "INFORMATION" PAGE

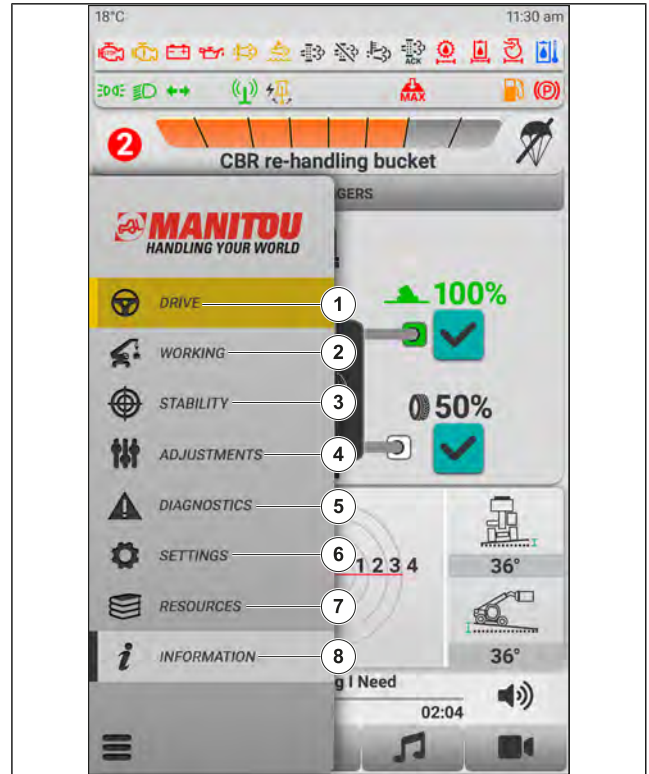


Figure 128: Menu Pages

## 2.6.6 "DRIVE" PAGE

The "DRIVE" page displays the main information related to driving.

The main information in the upper area relates to levels and actual values:

1. Tachometer (x100 rpm) (1).
2. Speedometer (km / h or mph) (2).
3. Engine coolant temperature gauge (3).
4. Diesel exhaust fluid (DEF) level gauge that provides information on the amount of DEF in the tank (4).
5. Fuel level gauge (5).
6. Hydraulic oil temperature gauge (6).
7. Forward - reverse direction indicator (7).
8. Total hours meter (8).
9. Partial hour meters (9).
10. Consumption (10).

The main information in the lower area relates to engine and transmission settings:

11. Setting the maximum speed of the rotating telehandler (11).
12. Engine revs setting (rpm) (12).

- 13. Continuous adjustment of the oil flow of the attachment line (13).
- 14. ECO STOP button (14) Enabling this feature allows the engine to stop after a certain time interval. Briefly press the button to enable or disable the feature. Once the button is pressed, it is highlighted.
- 15. "HANDLING" driving mode (15) This feature allows you to select the "HANDLING" driving mode: for handling loads in the work area. Briefly press the button to enable or disable the feature. Once the button is pressed, it is highlighted.
- 16. ECO MODE (16) Enabling this feature allows you to reduce fuel consumption if the driving speed is kept constant. Briefly press the button to enable or disable the feature. Once the button is pressed, it is highlighted.
- 17. Regeneration request button (17) Keep the button pressed to enable the feature. Once the button is pressed, it is highlighted.
- 18. Regeneration inhibition button (18) Press the button briefly to enable the feature. Once the button is pressed, it is highlighted.
- 19. Engine override feature button (19) Press the button briefly to enable the feature. Once the button is pressed, it is highlighted.

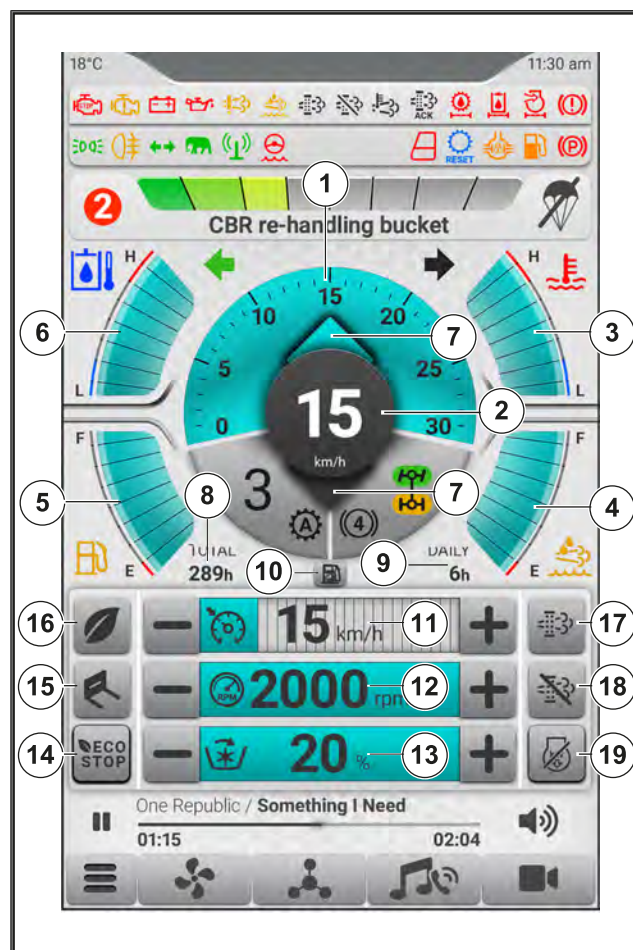


Figure 129: "DRIVE" page

### 2.6.7 "WORKING" PAGE

The "WORKING" page displays the main information of the telehandler and the reading of the main working data.

Furthermore, on the "WORKING" page, you have the possibility to select three tabs, one at a time, from the tab bar (4), at the top of the screen.

Always displayed in the central area of the screen is the load chart inherent to the attachment connected to the telescopic handler which changes automatically according to the working condition of the machine, stabilized or on tires.

Tab overview:

- GEOMETRICAL: Displays the chart and geometric values of the vehicle.
- DIAGRAM INFO (LOAD CHART): displays the complete chart without geometric values.
- SIMULATOR: displays and allows a simulation of maximum load.

"GEOMETRICAL" tab:

- Maximum permissible load.

- Weight of the lifted load.
- Length of the telescopic boom.
- Ground clearance.
- Telescopic boom angle.
- Working range.
- Turret angle.
- Coupling angle.
- Vehicle tilt angle.
- Position of the stabilizers.

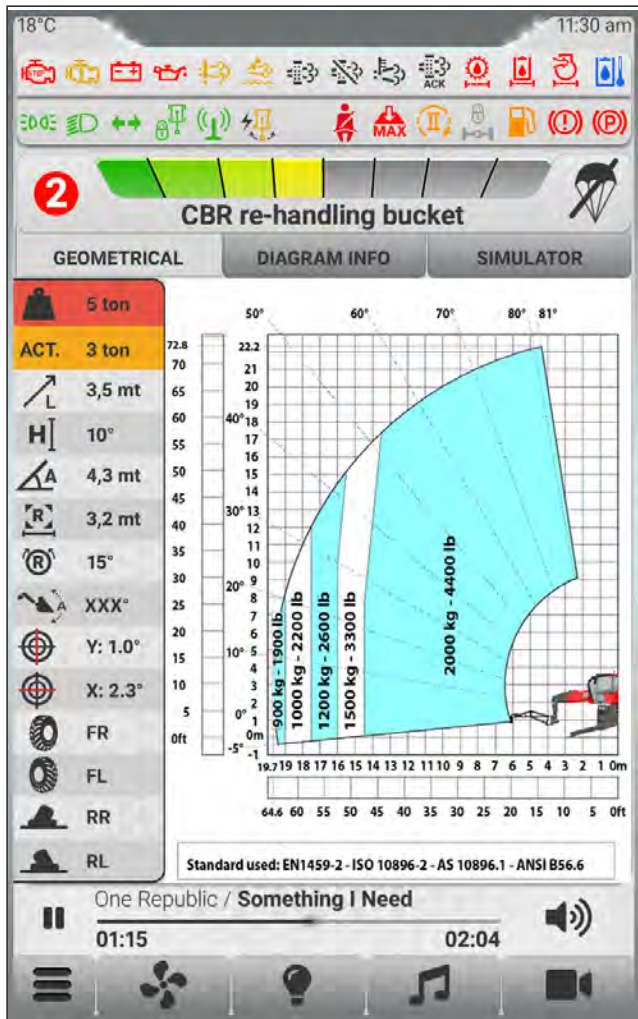


Figure 130: "GEOMETRICAL" tab

"DIAGRAM INFO" tab

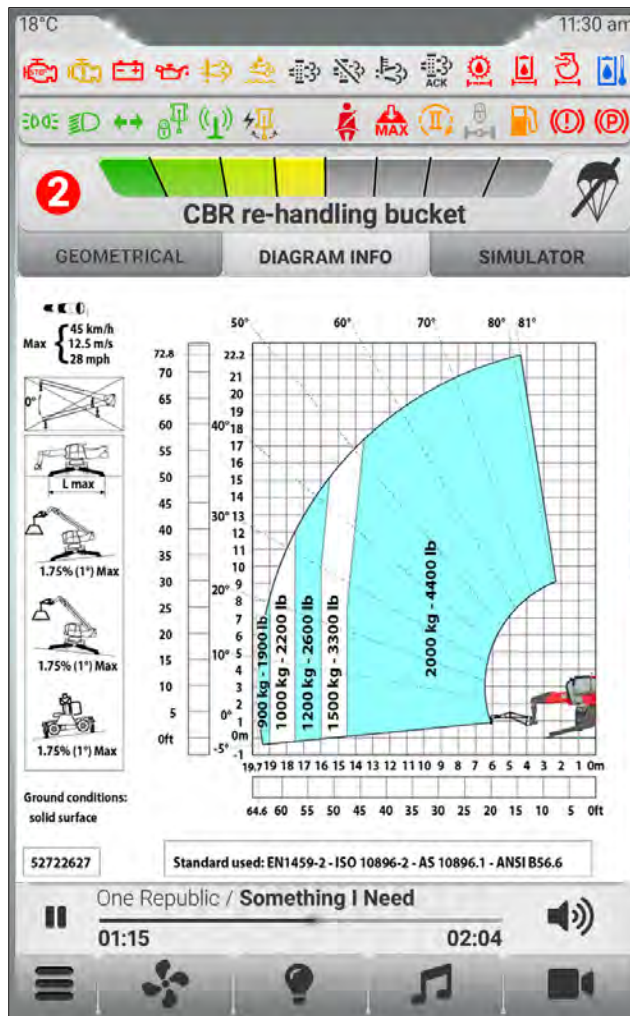


Figure 131: "DIAGRAM INFO" tab

"SIMULATOR" tab

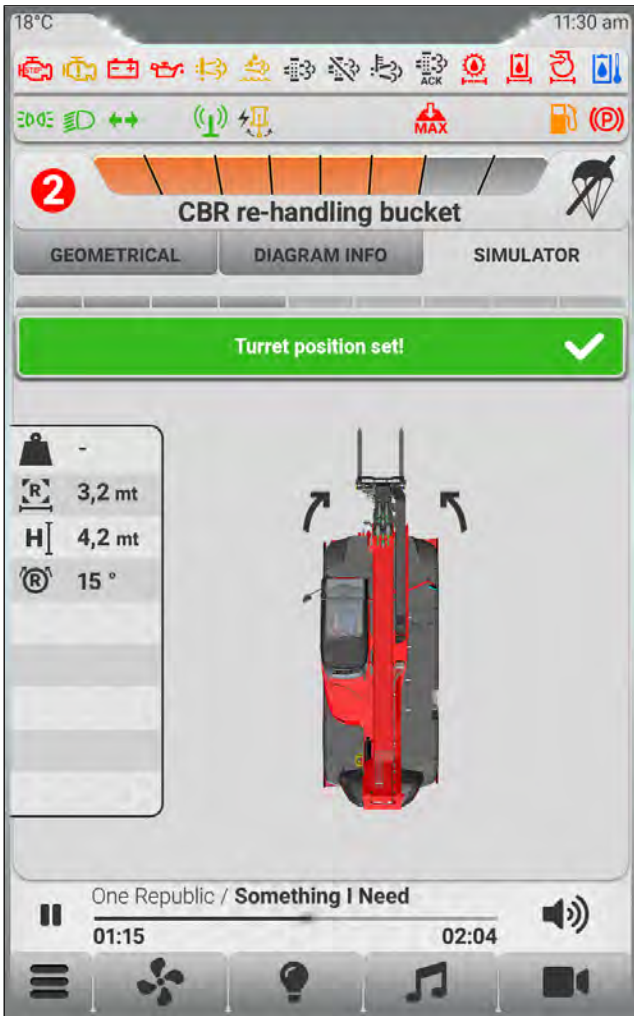


Figure 132: "SIMULATOR" tab

### 2.6.8 "STABILITY" PAGE

The "STABILITY" page displays the main information of the telehandler and the reading of the main working data regarding the stabilizers and the chassis.

On the page it is possible to manage the selection of stabilizers and automatic leveling.

The upper area displays the main information relating to the selection of the stabilizers, one by one or all or none, their position and their status.

This operation is linked to the control buttons on the right armrest of the driver's seat.

The condition of use of the telehandler is shown by the wheel and stabilizer foot symbols.

- Wheel symbol: machine on tires.
- Green stabilizer foot symbol: machine raised from the ground and placed on stabilizers.

Displayed at the bottom is the main information relating to the chassis.

The information displayed relates to the tilt of the chassis and the request for the self-leveling control.

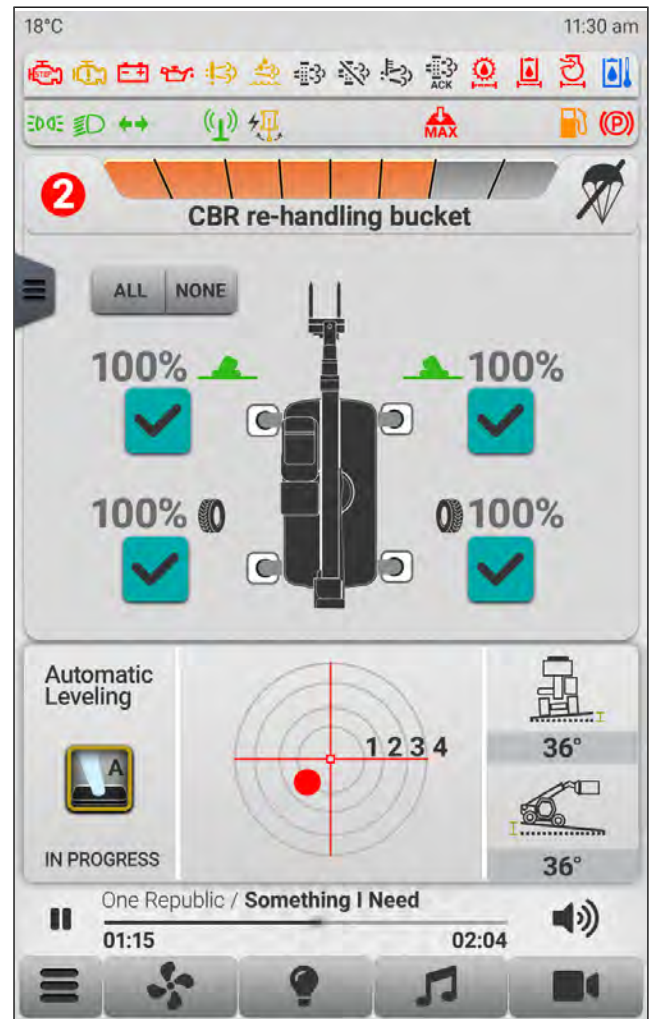


Figure 133: "STABILITY" page

### 2.6.9 "ADJUSTMENTS" PAGE

The "ADJUSTMENTS" page displays the main information regarding the geometric limits and the slowed speed of the hydraulic movements and for this it is necessary to select two tabs, one at a time, from the tab bar at the top of the screen.

Tab overview:

- **LIMIT:** displays and allows you to set the geometric limit parameters. This feature allows you to set an operational limit in a work area.
- **SLOWING DOWN:** displays and allows you to set the maximum speed parameters of the hydraulic movements.

"LIMIT" tab:

- "Corridor" workspace.
- "Wall" workspace.
- "Roof" workspace.

The top displays the geometric limit set.  
The bottom allows you to modify and enable / disable the feature.

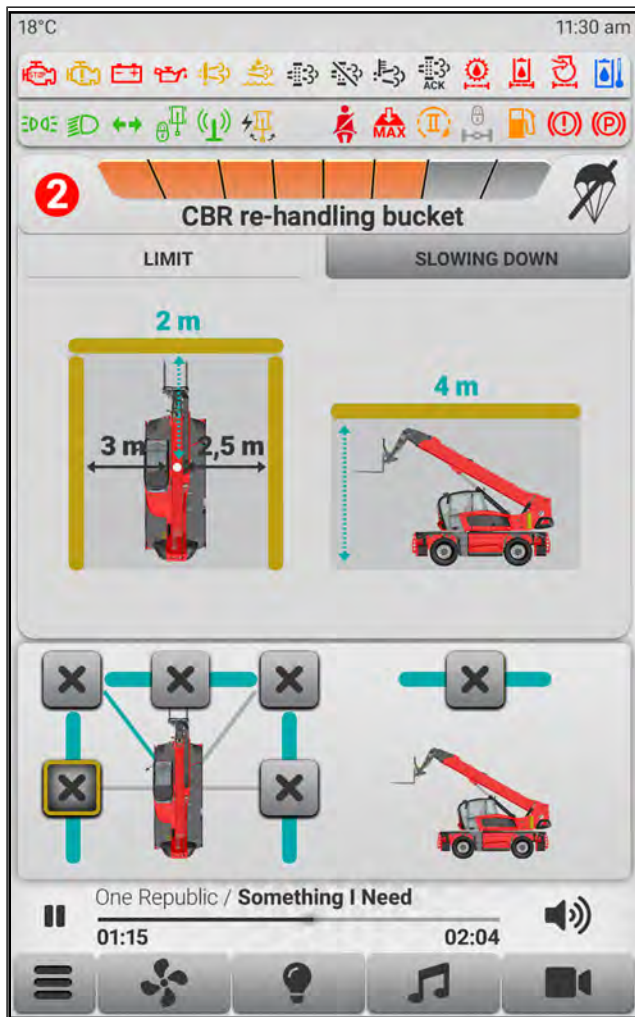


Figure 134: "LIMIT" tab

"SLOWING DOWN" tab:

- Maximum speed of ascent of the telescopic boom.
- Maximum speed of descent of the telescopic boom.
- Maximum extension speed of the telescopic boom.
- Maximum retraction speed of the telescopic boom.
- Maximum tilt-up speed of loads.
- Maximum tilt-down speed of loads.
- Maximum hourly rotation speed of rotating turret.
- Maximum counterclockwise rotation speed of the rotating turret.
- Maximum speed of control of the movements of the attachment: up, clockwise rotation, to the right, tilt up (depending on the attachment installed).
- Maximum speed of control of the movements of the attachment: descent, anticlockwise rotation, to the left, tilt down (depending on the attachment installed).

The maximum control speed of the hydraulic movements is expressed as a percentage: from 100% to 0%.

It is possible to set and save two working systems. Furthermore, it is possible to set the maximum control speed of the hydraulic movements by briefly pressing the "MAX" button.

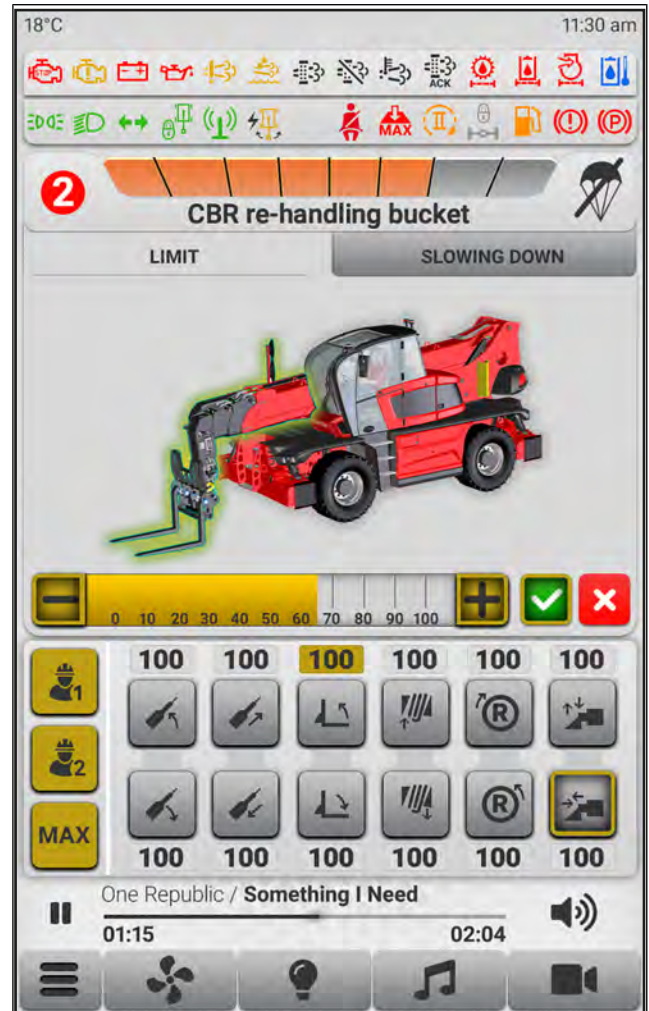


Figure 135: "SLOWING DOWN" tab

## 2.6.10 "DIAGNOSTICS" PAGE

The "DIAGNOSTICS" page displays the main information relating to active telehandler errors, with control unit, DTC code and occurrences.

You need to select three tabs, one at a time, from the tab bar at the top of the screen.

You can press on the error line to view its description, a pop-up window will open.

Tab overview:

- DTC (information about engine errors).
- INPUT / OUTPUTS.
- DATALOGGER (information about the CODE, date and transition).



Figure 136: DTC tab



Figure 137: INPUT / OUTPUTS tab

SPN	FMI	Transition	Date and time
522618	9	tr0	0:25:35 - 8/12/99
520739	5	tr0	0:25:34 - 8/12/99
520713	5	tr0	0:25:34 - 8/12/99
520738	5	tr0	0:25:34 - 8/12/99
520449	0	tr0	0:25:34 - 8/12/99
520713	5	tr0	20:37:51 - 3/12/99
522618	9	tr0	20:37:46 - 3/12/99
522007	13	tr0	20:37:46 - 3/12/99
522008	13	tr0	20:37:46 - 3/12/99
522009	13	tr0	20:37:45 - 3/12/99
520739	5	tr0	20:37:45 - 3/12/99
520738	5	tr0	20:37:45 - 3/12/99
520449	0	tr0	20:37:45 - 3/12/99
522020	2	tr0	20:37:45 - 3/12/99
522016	2	tr0	20:37:44 - 3/12/99

Figure 138: DATALOGGER tab

## 2.6.11. SETTINGS PAGE

### 2.6.11.1 "SETTINGS" PAGE

The "SETTINGS" page displays the main information set by the factory or by the operator relating to the "HMI" display.

The "SETTINGS" menu information is visible on the left side of the screen and is highlighted when selected.

The operator can display and change three settings.

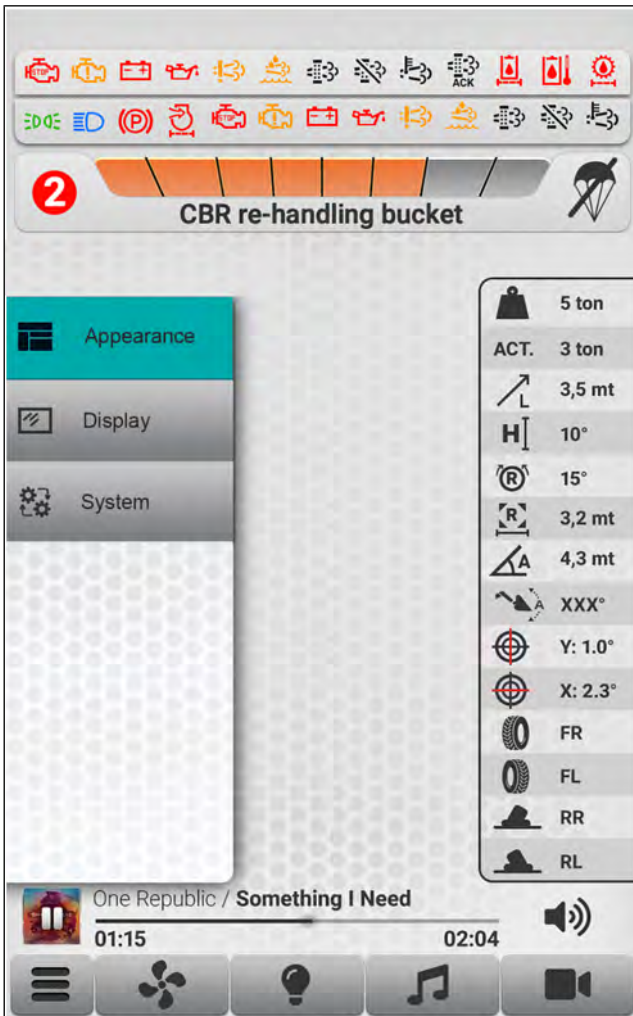


Figure 139: "SETTINGS" page

Table 179. "SETTINGS" menu overview

Menu	1st submenu	2nd submenu
<b>APPEARANCE</b>	Graphic design layout	Day / Night / Auto
	Color scheme	Blue / Yellow
	Unit of measure	Metric / Imperial
	Temperature unit	Celsius / Fahrenheit
<b>DISPLAY</b>	Brightness	0-100%
<b>SYSTEM</b>	Language	Italian, English, French, Spanish, etc.....
	Clock	Top right value
	Partial hours reset	
	Remote stop timer	

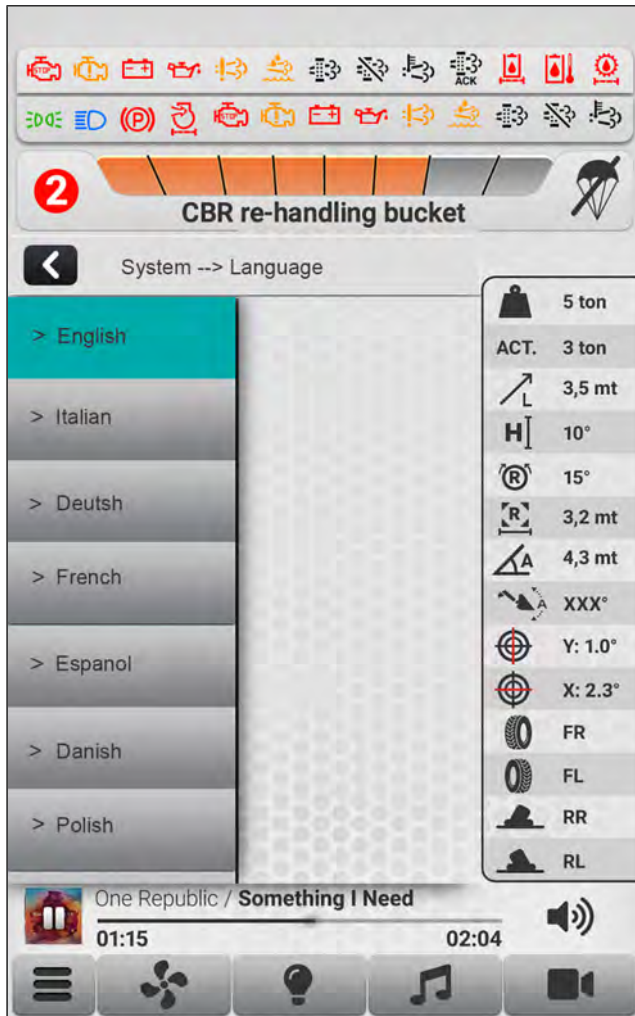


Figure 140: Example of "SYSTEM" submenu

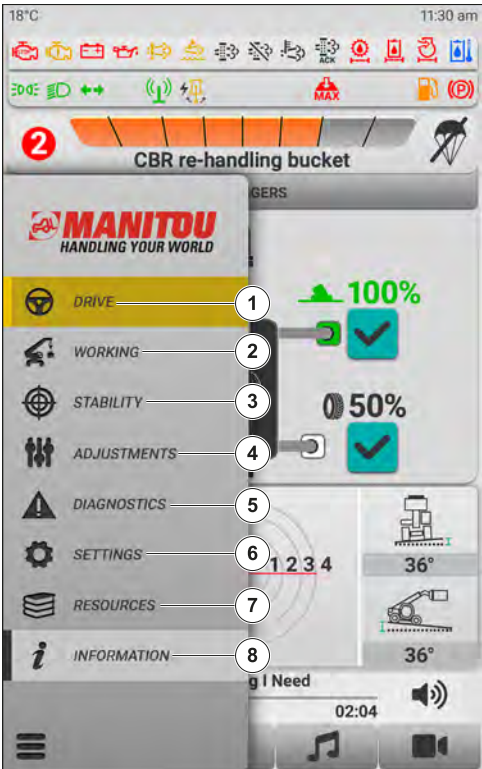
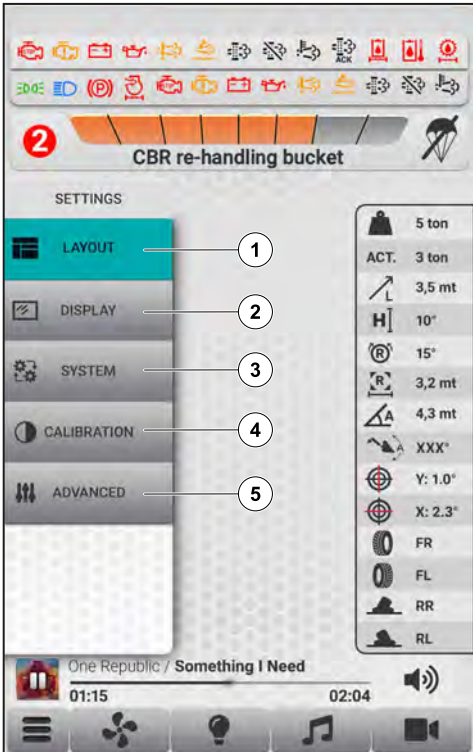


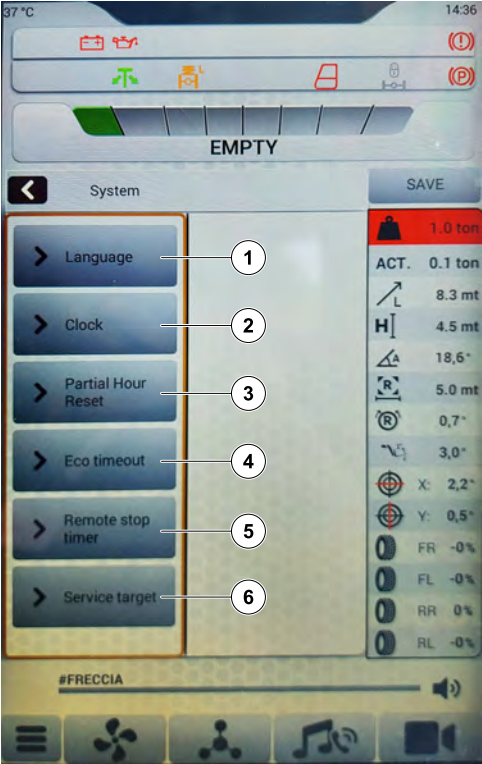
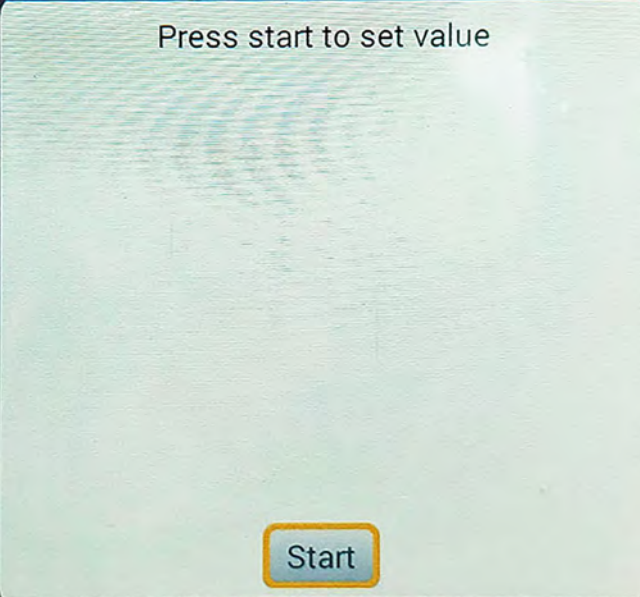
Figure 141: Example of "Night" graphic screen

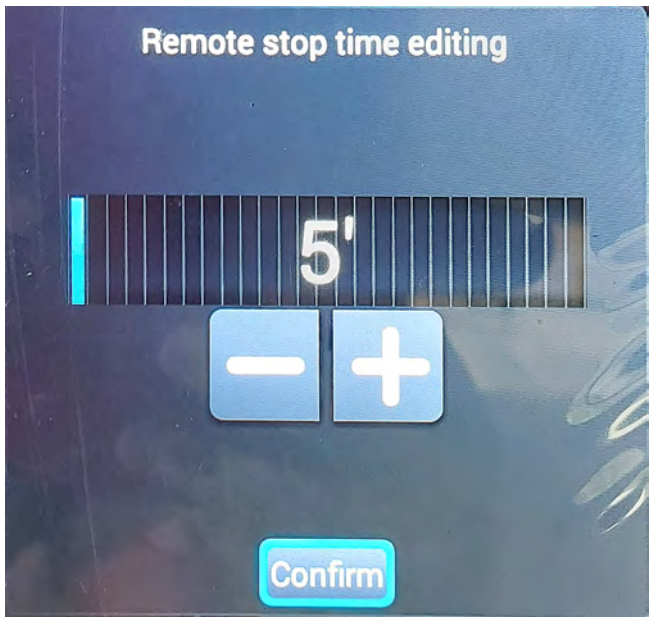
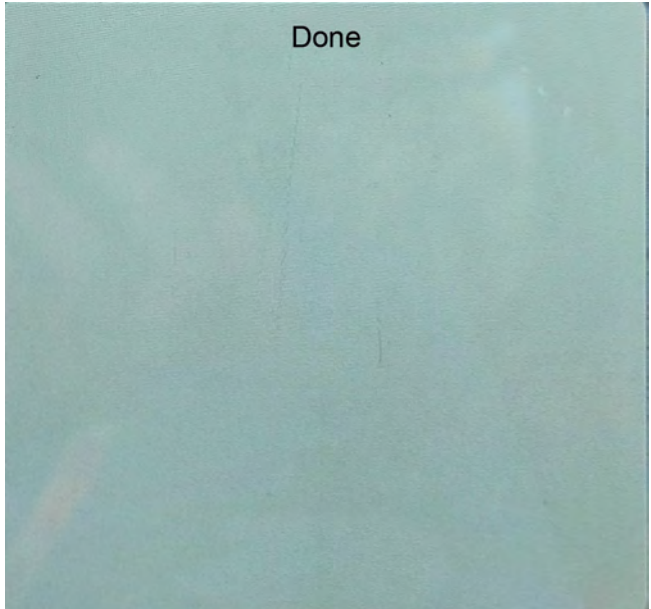


Figure 142: Example of "Yellow" color screen

### 2.6.11.2 SETTING OF THE REMOTE STOP TIME

	<b>Description</b>
 <p>The screenshot shows the main menu of the operator display. At the top, it displays the temperature (18°C) and time (11:30 am). Below this is a status bar with various icons. The main menu is titled "CBR re-handling bucket" and features the MANITOU logo. The menu items are: DRIVE (1), WORKING (2), STABILITY (3), ADJUSTMENTS (4), DIAGNOSTICS (5), SETTINGS (6), RESOURCES (7), and INFORMATION (8). The "DRIVE" option is highlighted in yellow and shows a 100% indicator. The "STABILITY" option shows a 50% indicator. The "SETTINGS" option is circled in red.</p>	<p>Navigate in the "MENU" section and select the "SETTINGS" page (6).</p>
 <p>The screenshot shows the "SETTINGS" menu. The menu items are: LAYOUT (1), DISPLAY (2), SYSTEM (3), CALIBRATION (4), and ADVANCED (5). The "SYSTEM" option is highlighted in teal. To the right of the menu, there is a list of system parameters with their current values: 5 ton, ACT. 3 ton, 3,5 mt, 10°, 15°, 3,2 mt, 4,3 mt, XXX°, Y: 1.0°, X: 2.3°, FR, FL, RR, and RL. At the bottom, there is a music player showing "One Republic / Something I Need" with a progress bar at 01:15 and a volume icon.</p>	<p>Select the "SYSTEM" page (3).</p>

	<b>Description</b>
	<p>Select the "Remote stop timer" page (5).</p>
	<p>Press "Start" the set value.</p>

	<b>Description</b>
	<p>Edit Remote Stop Time. Press "Confirm" to confirm.</p>
	<p>Done! Procedure Complete! Procedure Error, try again!</p>

### 2.6.12 "RESOURCES" PAGE

The "RESOURCES" page (ADDITIONAL RESOURCES) displays the main information relating to the documentation useful to the operator.

RESOURCES menu overview:

- DOCUMENTS
- VIDEOS
- TUTORIAL DISPLAY
- USER MANUAL

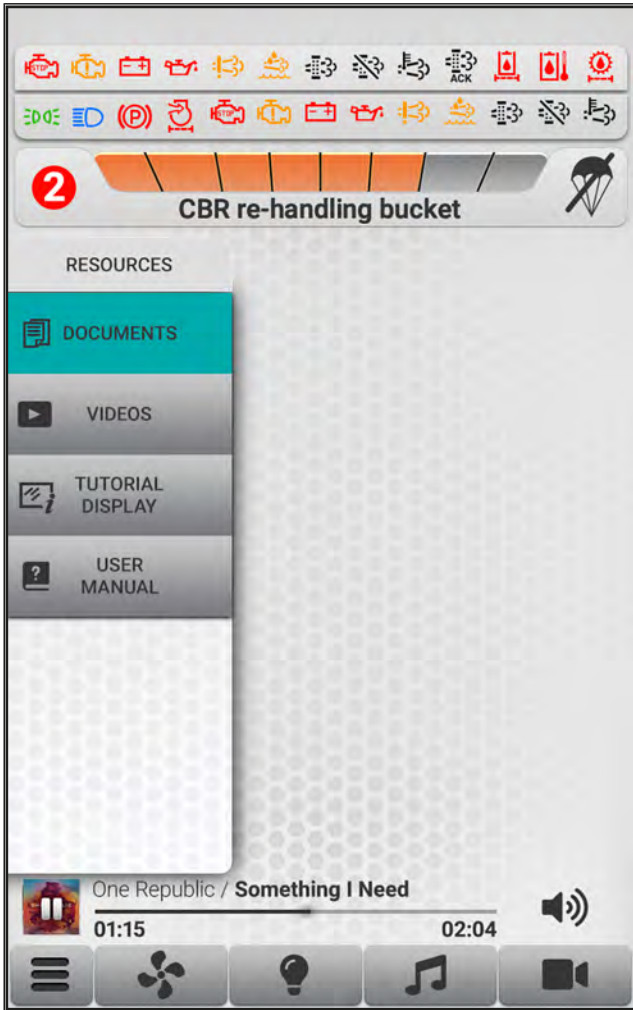


Figure 143: "RESOURCES" page

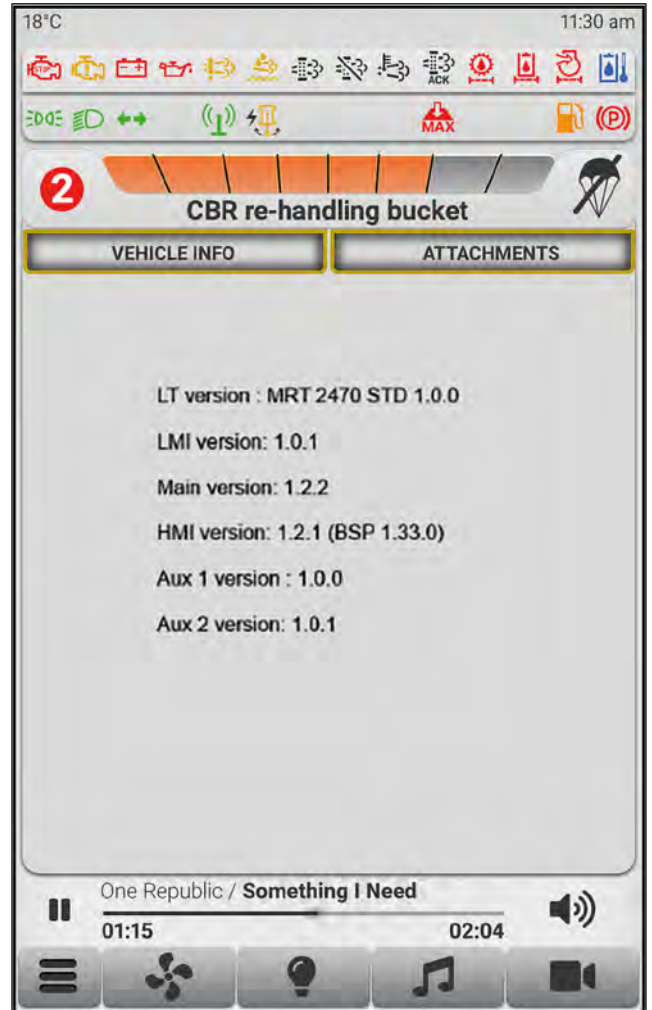


Figure 144: "VEHICLE INFO" tab

### 2.6.13 "INFORMATION" PAGE

The "INFORMATION" page displays the main information regarding the software version, the version of the load charts and the attachments list.

you need to select two tabs, one at a time, from the tab bar at the top of the screen.

INFORMATION tabs overview:

- VEHICLE INFO
- ATTACHMENTS (ATTACHMENT INFORMATION)

"VEHICLE INFO" tab, displays information about the software version:

- Load charts.
- LMI version.
- Main version.
- HMI version.
- Aux version.
- Aux 2 version.

"ATTACHMENTS" tab, displays the information relating to the list of attachments available in the flashing load table:

- Index
- Attachment name
- Acronym

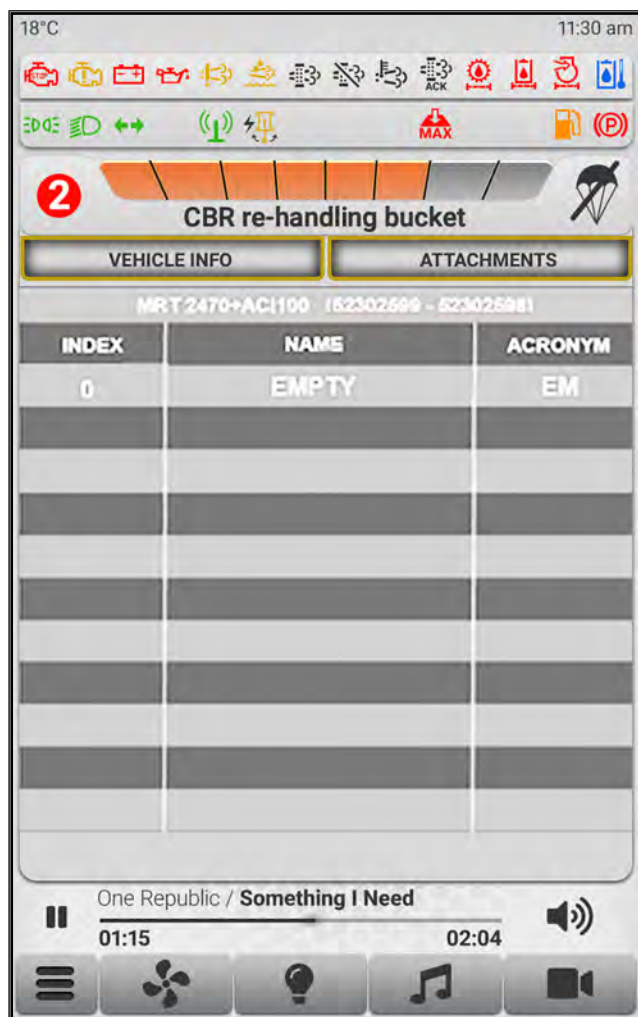



Figure 145: "ATTACHMENTS" tab

## 2.7. CHECK INDICATORS

### 2.7.1 JOYSTICK

The telehandler is equipped with two proportional electro-hydraulic capacitive joysticks, one to the right (1) of the operator and one to the left (2) both on the seat armrests to ensure better control and comfort.

 *The joysticks only work when grasped and with the cabin door closed or the cabin door open and the seat belt fastened.*

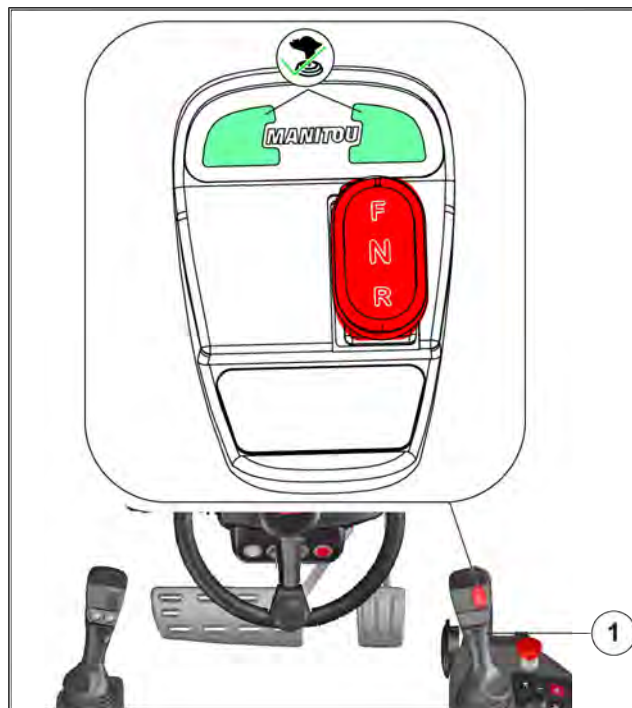


Figure 146: Right joystick

#### Joystick (1)

It can simultaneously carry out two double effect movements: lifting the load and tilting the forks.

To enable and perform the movements, hold the joystick.



To lift the load, pull the lever back.

To lower the load, push the lever forward.

To tilt the fork down, push the lever to the right.

To tilt the fork up, push the lever to the left.

Table 180. Selector overview

	Green LEDs lit on joystick, hydraulic movements enabled.
	Direction selector: Forward / Neutral / Reverse.

#### Joystick (2)

It can carry out three double effect movements simultaneously:

- Extension of the telescopic boom.
- Rotation of the turret.
- Control of the attachment.

To enable and perform the movements, grab the joystick.

To extend the telescopic boom, push the lever forward.

To retract the boom, pull the lever back.

To rotate the turret clockwise, push the lever to the right.

To rotate the turret counterclockwise, push the lever to the left.

To control the movements of the attachment, rotate the roller on the lever (2).

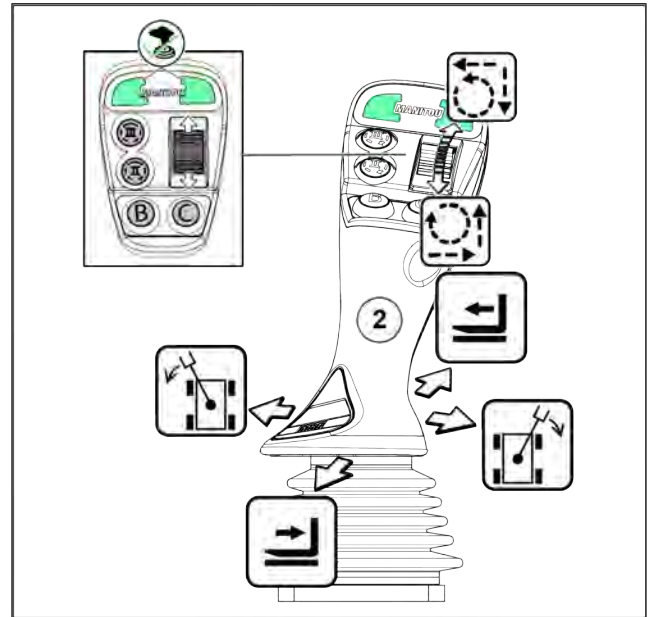


Figure 147: Left joystick

Table 181. Selector overview

	Vertical buttons: 2nd and 3rd hydraulic output at the boom head to select several movements of an attachment (optional).
	Horizontal buttons: these select multiple movements of a platform (if available).
	Green LEDs lit on joystick, hydraulic movements enabled.

### 2.7.2 BUTTONS AND CONTROLS

#### BUTTON FEATURES













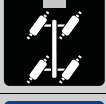


- Red button: safety.
- Orange button: Transmission / engine.
- Blue button: hydraulic system.
- Black button: other.




#### BUTTON DIAGNOSTICS

- If all buttons are off, there is a power supply problem, contact your dealer.
- If all buttons are flashing simultaneously, there is a connection problem, contact your dealer.

Table 182. BUTTONS OVERVIEW

Right armrest	
	Navigation and confirmation knob
	Preferences menu

<b>Right armrest</b>	
	Information menu
	Back
	Exclusion of hydraulic movements
	Beacon
	Hazard warning lights
	Automatic parking brake "manual mode"
	Automatic parking brake
	Travel safety system reset
	Emergency pump (only with platform)
	Opposite direction front and rear wheel drive (small turning radius)
	Front wheel drive (driving on road)
	Front wheel drive and rear wheel drive angle block
	Front and rear wheel drive in the same direction (lateral movement)
	Left front and rear stabilizer selectors
	Right front and rear stabilizer selectors




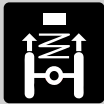

<b>Right armrest</b>	
	"Emergency stop" button
	Low / high gear selector
	Stabilizer control joystick











The movement of the stabilizers is possible through the small joystick (3) located on the right armrest. Move the Joystick:

•  
Back to raise the stabilizers (X1).

•  
Forward to lower the stabilizers (X2).



<b>Left armrest</b>	
	Boom suspension (optional)
	Forced boom suspension (optional)
	Upward suspension (depending on machine model)
	Upward suspension (depending on machine model)
	Disabling the forks tilt control

<b>Left armrest</b>	
	Disabling the attachment control
	Hydraulic block of the attachment
	Flow limiter of the attachment circuit for continuous hydraulic movement of the attachment
	Seat tilt forward (optional)
	Seat tilt back (optional)
<b>Steering column</b>	
	Button for enabling radio control
	Safety system exclusion key
	Control selector from cabin or from platform
	Red button for recovering the cab controls from the platform in the event of a stop
<b>Canopy (right side)</b>	
	Electric adjustment of the right door mirror (telescopic boom side)

### 2.7.3 SAFETY SYSTEM EXCLUSION KEY

The telehandler is equipped with an electronic safety system (MSS) which controls machine overload during work.

The system intervenes automatically by blocking the movements of the telescopic boom.

**⚠ DANGER**

#### Risk of vehicle overturning

With the MSS safety system off, the operator and telehandler are exposed to overload and / or tipping over of the vehicle.

Manually switch off the MSS only in exceptional cases and for safety reasons.

#### Key selector

To disable the MSS safety system, the operator must turn a key switch (1) in the cabin.

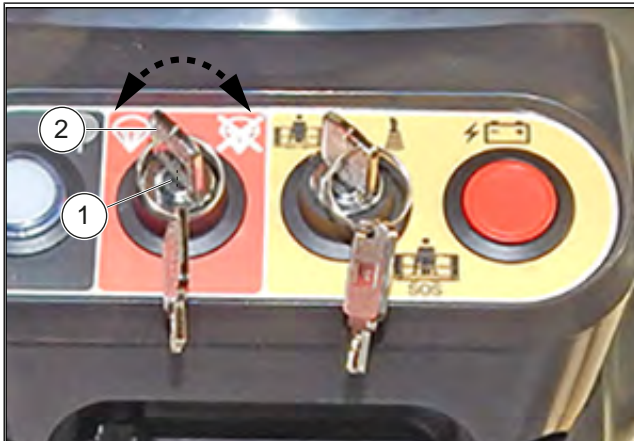




Figure 148: Key selector


The key (2) is stored inside a safety box (3) located behind the driver's cabin.



Figure 149: Safety box

The key selector (1) has two positions:

- Security system enabled 
- Security system disabled 

When in service, the key selector (1) (2) is turned to position  : MSS safety system enabled.

### 2.7.4 RADIO CONTROL FOR ATTACHMENT MOVEMENT AND TELESCOPIC HANDLER MOVEMENT

The Radio Control object is composed of:

1. Transmitter (push button panel) (1).
2. Receiver (2).



Figure 150: Radio control

3. Battery charger (3) and battery (3a).
4. Transmitter unit support (4) positioned in the cabin, behind the operator's seat.
  - Release the safety block (4b) to raise the boom (4a) that holds the transmitter unit (1) on the support (4).

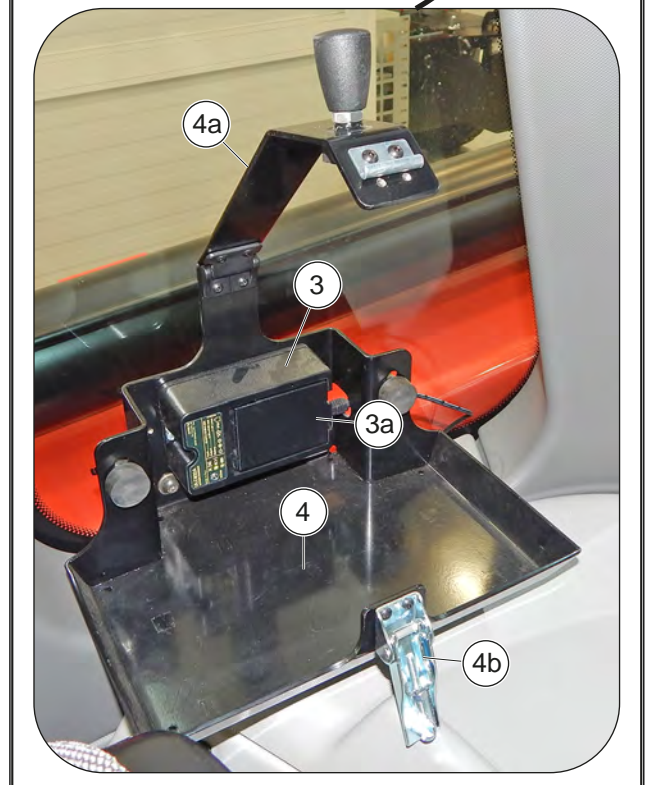


Figure 151: Transmitter unit and support

### Radio control identification

The serial number (SN) is the only reference that must be used to uniquely identify the radio control both in case of maintenance interventions and in case of declarations to concerned bodies.

The serial number (SN) and other information relating to the radio control are found on some plates both in the transmitter and in the receiver.

These plates must not be:

- Removed from their position (removal entails the immediate forfeiture of the warranty).
- Altered or damaged (contact MANITOU for replacement).

**Transmitter unit plates**

There are three plates in the transmitter unit:

1. Identification plate of the radio control.  
Information contained: the serial number of the radio control (SN), a QR code and the year of manufacture.
2. Transmitter unit identification plate.  
Information contained: the year of manufacture, a QR code and the identification number of the transmitter unit (TU ID).
3. Technical data plate.  
Information contained: The Model, the Type and the main technical data of the transmitter unit, the marking and any trademarks of the radio control.

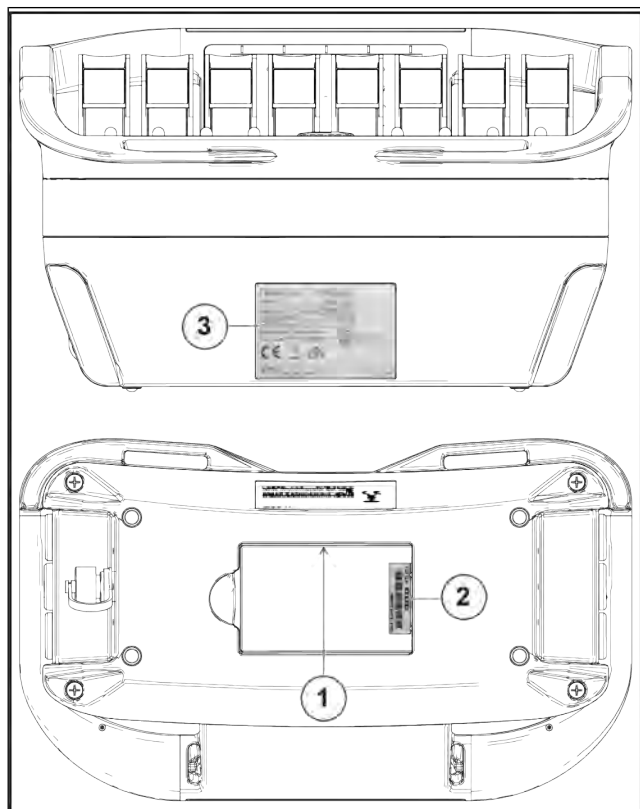


Figure 152: Transmitter unit plates

**Receiver unit plates**

There are two plates on the receiver unit:

1. Receiver unit identification plate.  
Information contained: The serial number (SN) of the radio control, a QR code and the year of manufacture.
2. Technical data plate.

Information contained: The Model, the Type and the main technical data of the receiver unit, the marking and any trademarks of the radio control.

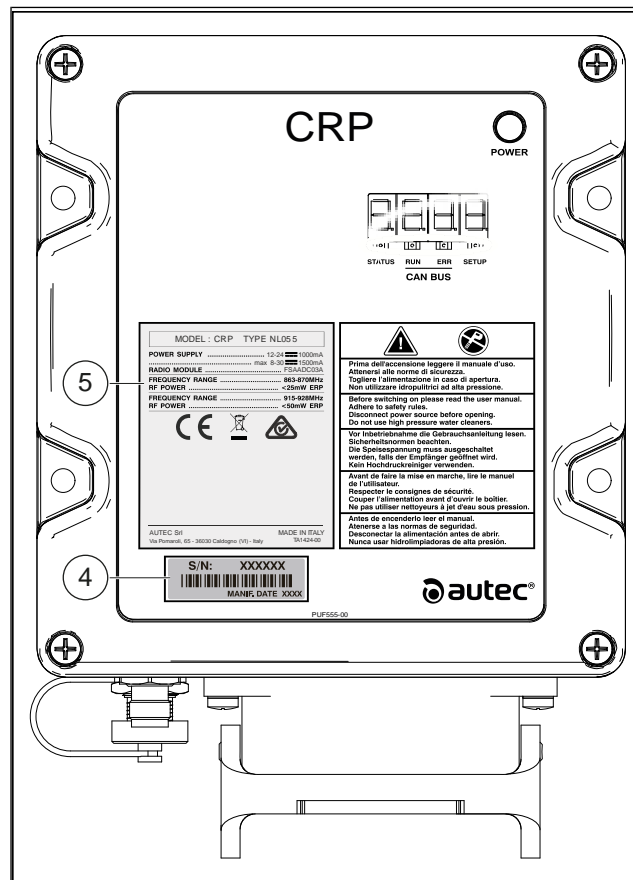


Figure 153: Receiver unit plates

**Transmitter unit push-button panel**

1. Button to confirm the recognition of the attachment on the display.
2. Engine and horn start consent.  
Sound the horn when the radio control is started.
3. M-KEY: The M-Key allows for powering the transmitter unit.  
Push the M-Key all the way into its housing.
4. Emergency electric pump button for platform rescue:
  - To retract the telescopic boom: keep the button pressed to activate the rescue pump.
  - Perform only the maneuvers strictly necessary to return to the ground.
5. Engine start button:
  - Before switching on, the red EMERGENCY STOP button must be turned off.
  - Press the button (2) then press the button (5) to start the engine.
6. Wired control connector.  
Maneuvering consent from the platform.

7. Scroll display pages.
8. Display illumination.
9. Not used.
10. Telescopic boom lights switch.
11. Attachment display and scroll page.
12. Monitor "HMI" human-machine interface (12) consisting of a 2.8" display (12a) and several LEDs (12b) that display and indicate:
  - the working and stability information of the vehicle,
  - engine warnings,
  - the attachment in use,
  - the status of the load,
  - alerts regarding the status of the transmitting unit and receiving unit.
13. Right joystick:
  - Boom lifting / lowering.
  - Forward / backward tilting of the load (selected TILT).
  - AUX attachment control (selected AUX).
14. Left joystick:
  - telescopic boom extension / retraction.
  - turret rotation.
15. Attachment movement selector.
16. Attachment movement selector - 12V in boom head.
17. Attachment movement selector.
18. Consent load tilting or platform leveling.
19. Red "EMERGENCY STOP" button.  
When pushed, it allows the heat engine to be stopped.  
In case of danger, it allows the user to stop hydraulic movements.  
To restore hydraulic movements, turn the red button clockwise.
20. Engine speed management switch (RPM).
21. Hydraulic movement speed selector.
22. AUX (attachment) or TILT (load/platform tilt) movement selector.
23. Multiple movements of the attachment: "I/II" and "Hydraulic locking of the attachment."

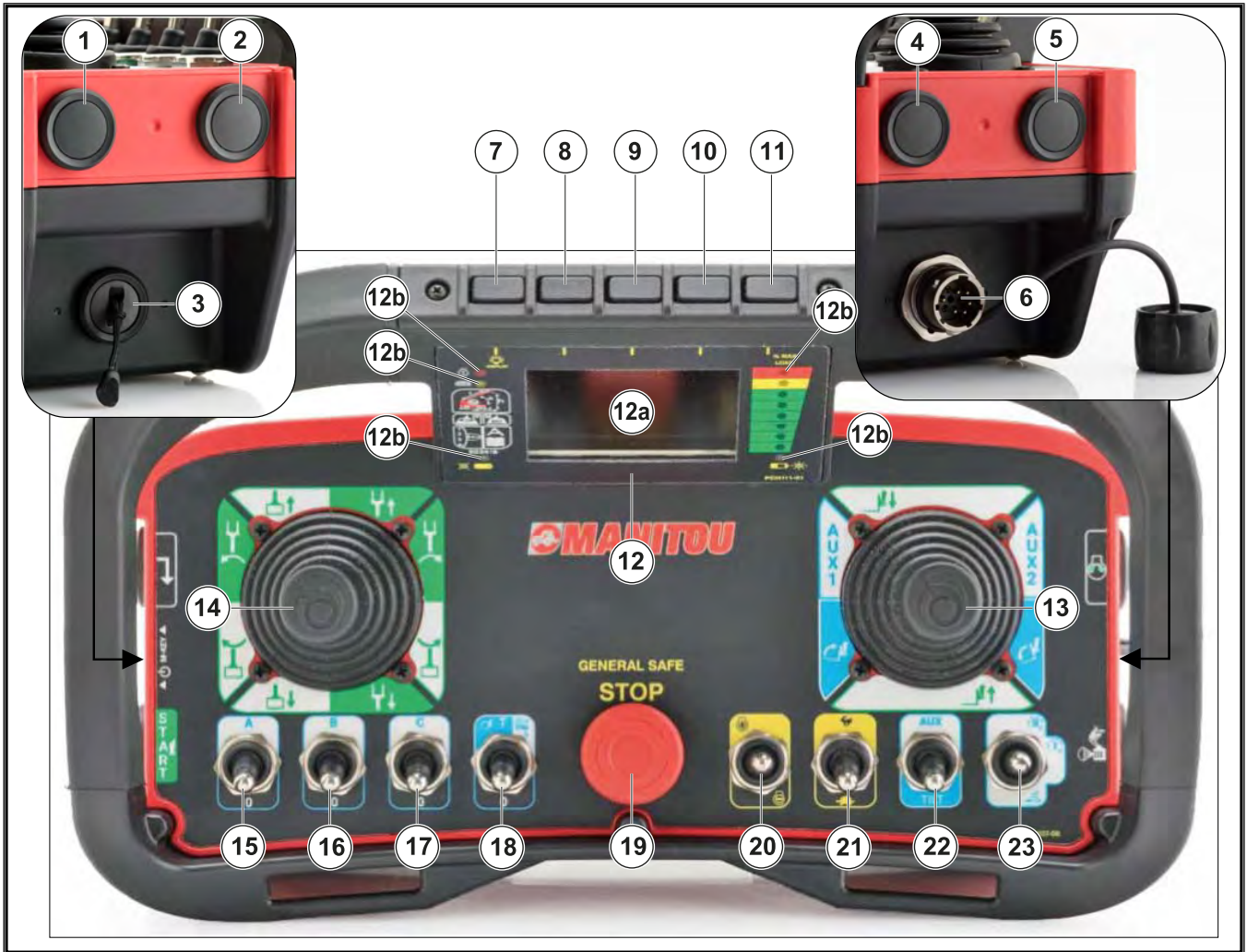


Figure 154: Transmitter unit push-button panel

### 2.7.5 REMOTE CONTROL "HMI" MONITOR

The "HMI" (human-machine interface) monitor consists of:

1. LEDs INDICATORS (1)
2. DISPLAY (2)

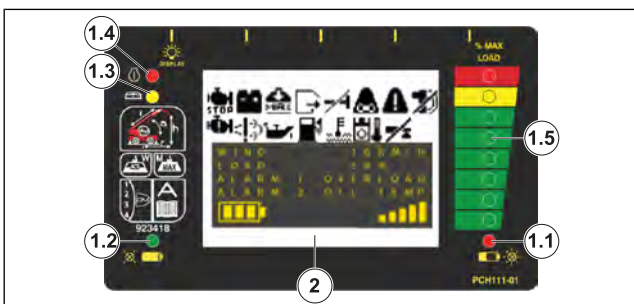


Figure 155: Monitors - LEDs Indicators and Displays

#### LEDs INDICATORS.

List of LEDs indicators and functions.

#### RED LED (1.1)

- Off: indicates that the transmitter unit is working properly.
- Blinking on: indicates that the battery of the transmitter unit is getting low.
- Blinking on for 2 seconds: indicates that the transmitter unit is not working properly.
- Blinking on 1 time: when turned on, it indicates that the transmitting unit detects the "EMERGENCY STOP" button active or faulty.
- Blinking on 2 times: when turned on, it indicates that the transmitting unit detects an active or faulty "SAFETY" command.
- Blinking on 3 times: when turned on, it indicates that the transmitter unit detects low battery.
- Blinking on 4 times: when turned on, it indicates that the transmitting unit detects an active or faulty "ALARM" command.

#### GREEN LED (1.2)

- Off: indicates that the transmitter unit is off.

- Fast flashing light: indicates that the transmitter unit is on and the radio link is off.
- Slow flashing light: indicates that the radio control is active and the radio link is present.

#### YELLOW LED (1.3)

- Flashing light + buzzer: indicates that the security system is in lockout.
- Steady on: indicates that the aerial platform is overloaded.

### ⚠ DANGER

If the aerial platform is overloaded, all platform movement controls are inhibited.

If the LED lights up while climbing the aerial platform, it means the platform is overloaded. It is necessary to stop and relieve the platform.

### ⚠ DANGER

#### RED LED (1.4)

- On: indicates that the stabilizers have not been well positioned (according to vehicle model).
- On: indicates that the access hatch to the aerial platform has not been closed tightly.
- On: indicates that the "forward or reverse" direction of vehicle movement is selected.



*For the ORH COUVREUR aerial platform only, the functions of the red LED (1.4) are included in the yellow LED (1.3)*

#### LEDs LOAD CONDITIONS, % , AND ALARMS (1.5)

The LEDs bar, indicates the percentage of load lifted compared to the maximum load that can be lifted under those working conditions. The LEDs bar consists of three colors, green, yellow and red, referring to the safety system that constantly monitors and supervises the status of the load.

- Green led on: indicates the safety zone of load lifting
- Yellow LED on: indicates the alarm zone of load lifting. Load lifted more than 90% of the permissible load (external buzzer on)
- Red LED on: indicates the lockout zone. Load lifted higher than 100% of permissible load (horn and external red light on).

## DISPLAY (2)

The color screen display built into the transmitter unit shows and informs the operator about the main work phases of the vehicle.

Several control modes in the display memory can be selected using the buttons on the transmitter unit.

List of display screens:

1. Start-up screen
2. Background screen
3. Work screen
4. Joystick screen
5. Engine screen
6. Stability screen
7. Attachments screen
8. Diagnostics screen

#### "LOGO" screen

Upon startup, the display shows the Manitou startup animation for 4 seconds while waiting for the application to be ready. The Manitou logo appears after activation of the receiver unit.



Figure 156: Start-up screen

#### Background screen

The fixed characteristics of the display interface are three areas:

- Top (1).
- Center (2).
- Bottom (3).

#### Overview

- Top: contains the operation indicators and the machine alarm lights.
- Center: contains the main view of the selected screen.

- Bottom: contains the battery level indicator of the transmitter unit and the power indicator of the communication radio signal.

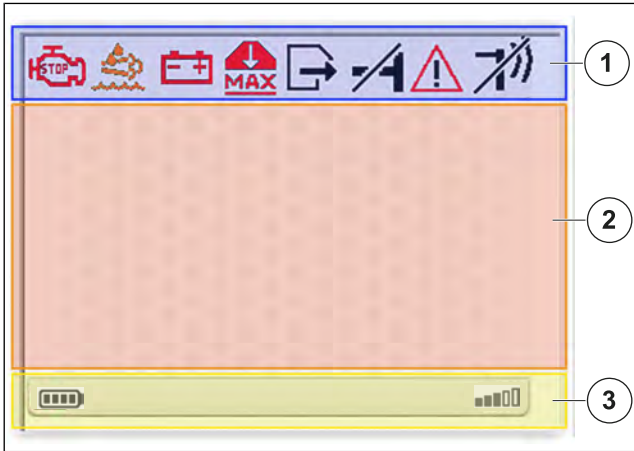


Figure 157: Background screen — area

**Overview of symbols and features:**

Table 183. Indicators

INDICATORS	
	Transmitter battery level.
	Remote control frequency power.
	Fuel reserve. When the machine reaches the reserve, in addition to the icon lighting up, the machine automatically switches to the Engine Screen for 3 seconds and an alarm sounds for the same amount of time.
	Platform door open.
	Pin not inserted.
	Attachment not recognized.
	Stabilizers not on the ground.

Table 184. WARNING LIGHTS

WARNING LIGHTS	
	Serious engine failure.
	Engine malfunction.

WARNING LIGHTS	
	Diesel exhaust fluid (DEF) tank level.
	Emission-related malfunction of the exhaust after-treatment system or of the DEF supply.
	Engine oil pressure low.
	Alternator excitation.
	Hydraulic oil temperature high.
	Engine water temperature boiling.
	General alarm.
	Platform overload.

**Work screen**

The work screen contains information about the machine movements and the icons relating to information.

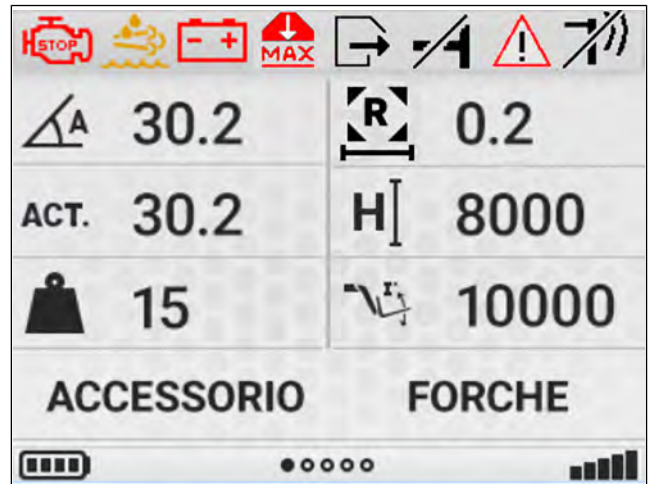






Figure 158: Work screen

**Overview of icons and features:**

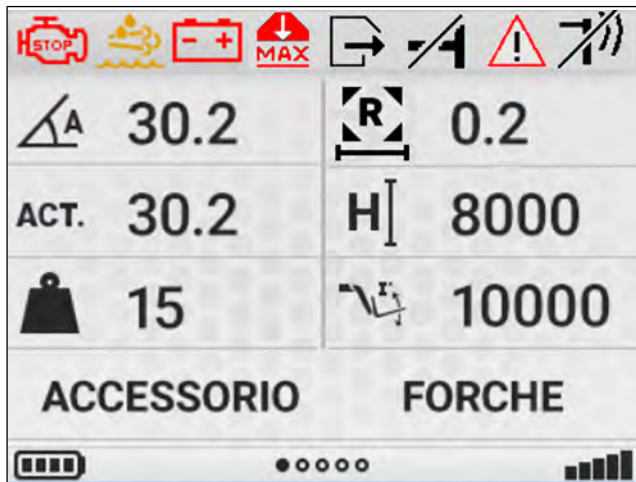
Table 185. Icons

ICONS	
	Telescopic boom angle.
	Weight of the lifted load.

ICONS	
	Maximum permissible load. When the attachment used is a platform, the maximum capacity that is displayed on the Work Screen is the same as the nominal capacity of the platform.
	Working radius: measurement of the distance from the center of the machine to the projected point of application of the load.
	Ground clearance.
	Attachment quick coupling tilt angle.
<b>FORK-S</b>	Attachment in use.

**Work screen**

The work screen contains information about the machine movements and the icons relating to information.








The screenshot shows a top bar with icons for STOP, battery, MAX, and other functions. Below are data points: Telescopic boom angle (30.2), Working radius (0.2), ACT. weight (30.2), Ground clearance (8000), Maximum permissible load (15), and Attachment quick coupling tilt angle (10000). At the bottom, it displays 'ACCESSORIO' and 'FORCHE' with a battery level indicator.

Figure 159: Work screen

**Overview of icons and features:**

Table 186. Icons

ICONS	
	Telescopic boom angle.
<b>ACT.</b>	Weight of the lifted load.
	Maximum permissible load.
	Working radius: measurement of the distance from the center of the machine to

ICONS	
	the projected point of application of the load.
	Ground clearance.
	Attachment quick coupling tilt angle.
<b>FORK-S</b>	Attachment in use.

**Joystick screen**

The Joystick screen contains information about the Joystick controls and the solenoid valves control to perform a movement.





The screenshot shows a top bar with icons for STOP, battery, MAX, and other functions. Below are data points: RPM (1000), Joystick control (100), Speed of motion (100), YW (100), and W (100). At the bottom, it displays 'ACCESSORIO' and 'FORCHE' with a battery level indicator.

Figure 160: Joystick screen

**Overview of icons and features:**

Table 187. Icons and acronyms

ICONS AND ACRONYMS	
<b>RPM</b>	Envine revolution acronym.
	Joystick control.
	Speed of motion (s).
<b>YW</b>	Solenoid valve control.
<b>W</b>	Warning active.
<b>FORK-S</b>	Attachment in use.

**Engine screen**

The Engine screen contains information about the three-phase motor.

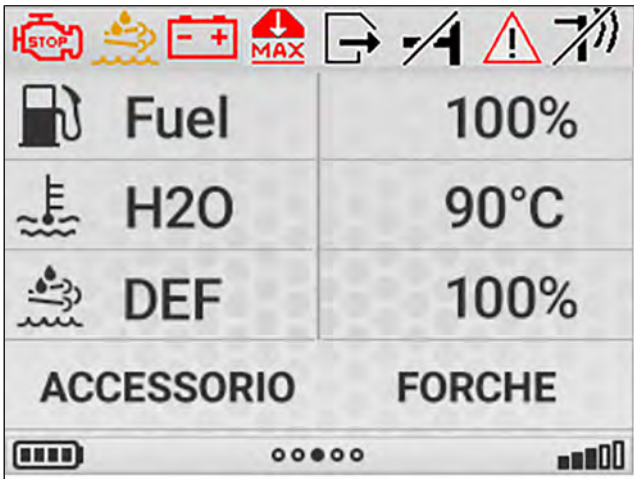


Figure 161: Engine screen

Overview of icons and features:

Table 188. Icons

ICONS	
	Fuel quantity indication (%).
	Coolant temperature indication (°C / °F).
	DEF additive quantity indication (%).
<b>FORK-S</b>	Attachment in use.

Stability screen

The Stability screen contains information about the inclinometer on the vehicle.



Figure 162: Stability screen

Overview of icons and features:

Table 189. Icons

ICONS	
	Lateral tilt indication (°).
	Longitudinal tilt indication (°).
<b>FORK-S</b>	Attachment in use.

Attachments screen

The attachments screen contains:

- A picture of the attachment.
- The possible movements that can be carried out.

Several pages concerning the attachments are saved and to select the desired one, press the button above the display: "scroll attachments pages".



Figure 163: Scroll attachments pages button

The moment a movement is carried out, the display returns to the Work Screen.

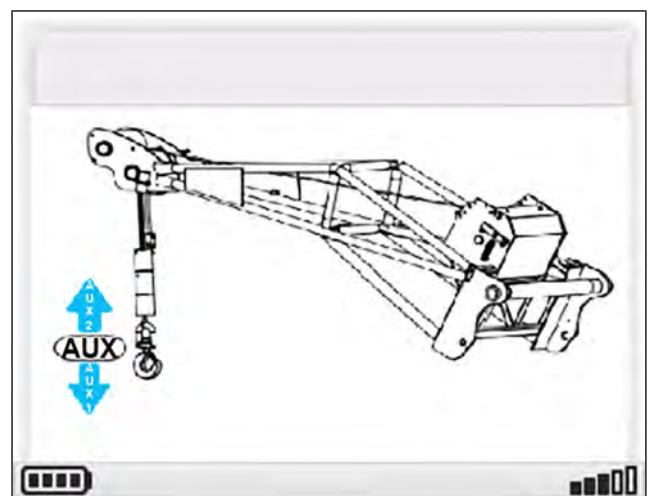


Figure 164: Attachments screen

Diagnostics Screen

The Diagnostics screen contains in 5 different screens the information about the errors or the malfunctions of remote control communication.

To open the diagnostics screens, hold down the button (1) above the display for 3 sec.

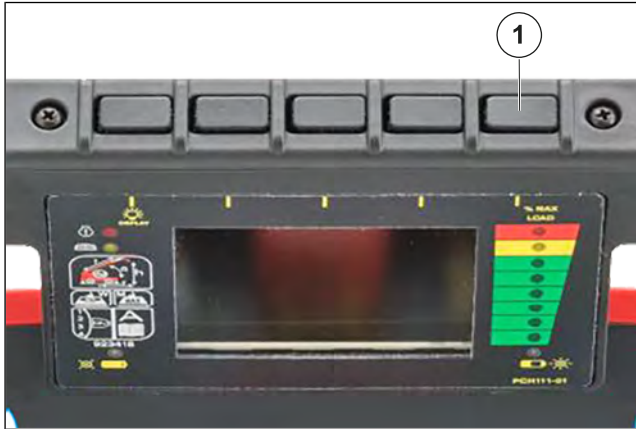


Figure 165: Diagnostics screen selection button

Diagnostics screen 1: contains information about the firmware and application in the remote control.

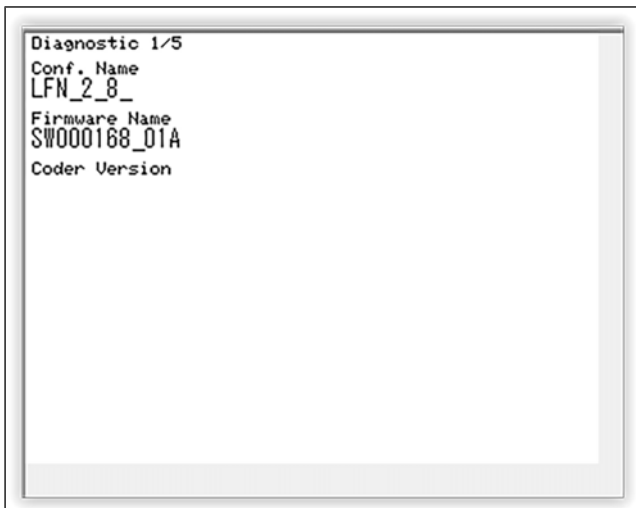


Figure 166: Screen 1

Diagnostics screen 2: contains information about the active alarms on the remote control, indicating whether an alarm is present via the color of the respective dot.

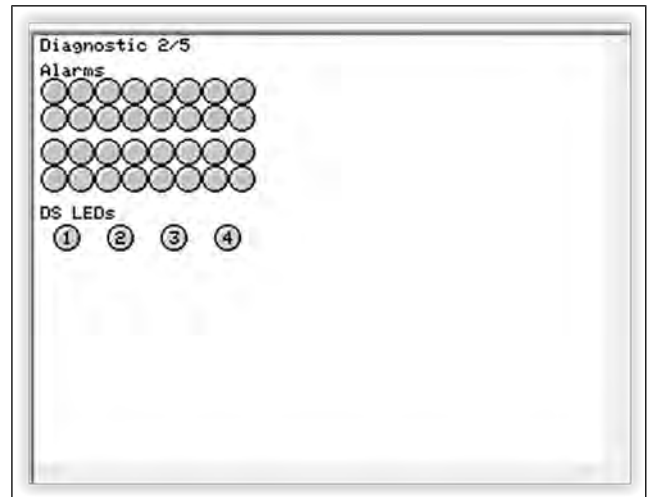


Figure 167: Screen 3

Diagnostics screen 3: contains information about the viewing strings.

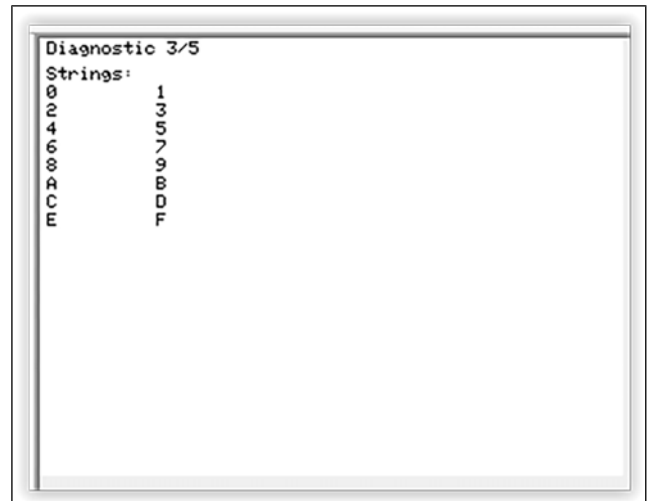


Figure 168: Screen 2

Diagnostics screen 4: contains information about the activation of digital signals generated by the remote control.

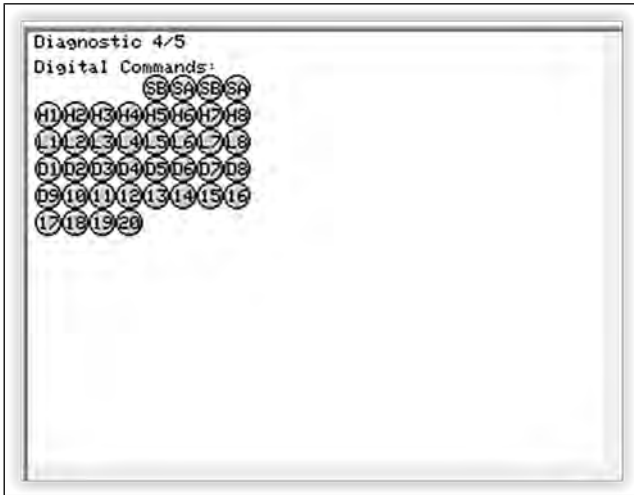


Figure 169: Screen 4

Diagnostics screen 5: contains information about the Joystick controls, in particular the percentage control filling the bar.

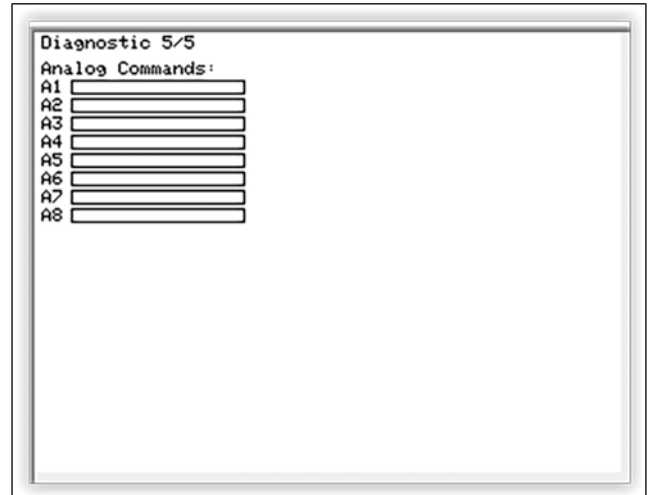


Figure 170: Screen 5

## 2.8. OPTIONAL

### 2.8.1 AIR CONDITIONING



*The air conditioning works only when the telehandler motor is running. When the air conditioner is on, always work with the cabin closed. During the winter: ensure correct operation and the effectiveness of the air conditioning system. Activate the compressor once a week, even if for a short time, to ensure the lubrication of the internal seals. In cold climates: warm up the engine before starting the compressor to allow the liquid refrigerant, accumulated in the lower part of the compressor circuit, to turn into gas thanks to the action of the heat emitted by the engine. Liquid refrigerant can damage the compressor. Do not try to repair any faults. If the air conditioner is not working properly, contact an authorized dealer.*

The specific controls of the Air Conditioning system are available on the HEATING and AIR CONDITIONING page together with the ventilation and heating controls.

To access the HEATING and AIR CONDITIONING


page, briefly press the touch button  on the button bar, at the bottom of the HMI Display.



Figure 171: Air conditioning

Table 190. AC specific commands overview:

	Max windshield defrost (33° C - 91.4° F and steady speed).
	Air conditioning ON / OFF.
	Automatic control.

On the HEATING and AIR CONDITIONING control panel, briefly press the touch buttons to enable or disable all features.

## 2.8.2 SIDE REAR-VIEW MIRRORS

Move the control (1) to adjust the visibility from the left (1A) (cabin side) or right (1B) (engine side) rear view mirror.

Turn the knob (1) clockwise (A) to select the left rear view mirror (1A).

Turn the knob (1) counterclockwise (B) to select the right rear view mirror (1B).

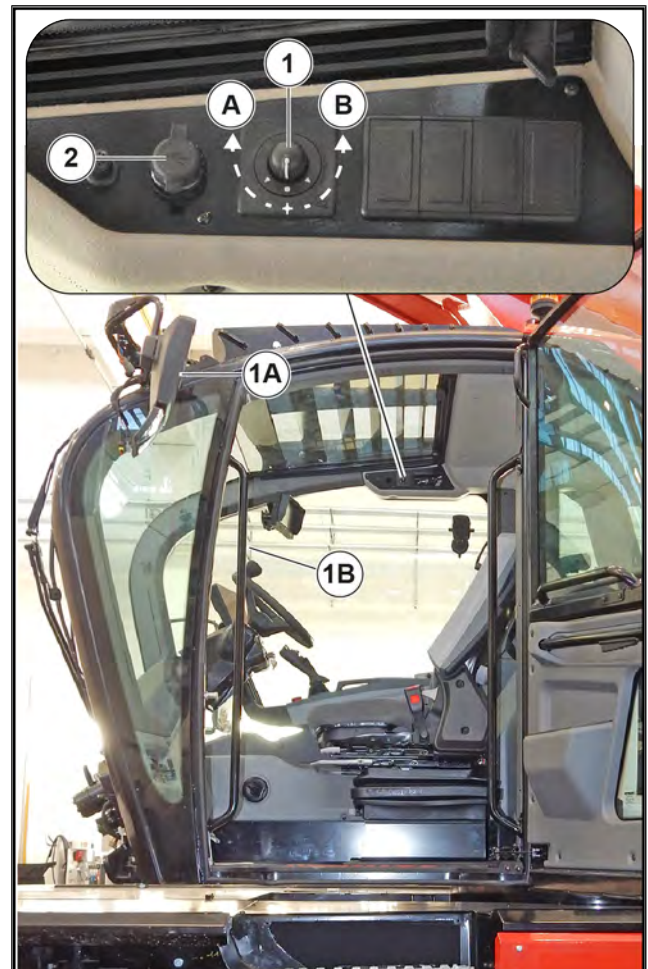


Figure 172: External side rear view mirrors control and USB port

## 2.8.3 BOOM SUSPENSION

The boom suspension allows for absorbing the shocks of the forklift truck on uneven terrain (example: moving straw in a field).

### Activation

There are two types of activation:

1. AUTO key (1), activation above 5 km / h / 3.1 mph.
2. FORCED key (2), standard activation requested by the operator.

On keys (1) and (2) a LED lights up (1a) and (2a) to indicate that the feature is enabled.

### Operation

- Rest the forks or attachment on the ground and raise the front wheels just a few centimeters.
- Press key (1) or (2), the LED (1a) or (2a) lights up to indicate that the boom suspension is enabled.
- Press key (1) or (2) again, so that the LED (1a) or (2a) switches off to indicate that the boom suspension is disabled.

**!** Boom suspension is enabled up to a lifting height of 3 m / 9.8 ft from the pivot axis of the plate to the ground with boom retracted.

Boom suspension is disabled:

- Operating over 3 m / 9.8 ft in height or carrying out another hydraulic movement (tilt, extension, descent, attachment),
- Operating with an articulated platform.

If the boom suspension is temporarily disabled, the LED (1a) or (2a) of the key goes out.

When the heat engine is off, the boom suspension is automatically disabled.

On the button (1) the LED lights up (2) to indicate that the feature is active.

The operator can operate the two pins (X, Y) by holding down the button (1) and pressing the optional control rocker button (4) on the left joystick (3):

- downwards, the two pins come out and block the attachment;
- upwards, the two pins retract and release the attachment.

Releasing the button (1), the operator deactivates the hydraulic attachment blocking device and restores the standard controls of the option.



Figure 173: Boom suspension

### 2.8.4 HYDRAULIC BLOCK OF THE ATTACHMENT

Precautions to be taken if the machine is supplied with “hydraulic block of the attachment” device.

This electrically controlled hydraulic movement device allows you to block or unblock an attachment from the operator's seat.

The device operates two pins (X, Y) which move horizontally on the quick coupling, outwards (blocking the attachment) and inwards (unblocking the attachment).

**!** To block the attachment, the two blocking pins must protrude completely from the quick coupling holes.

#### Description of controls

To select the “hydraulic attachment block” device, the operator must keep pressing on the button on the control console (1).

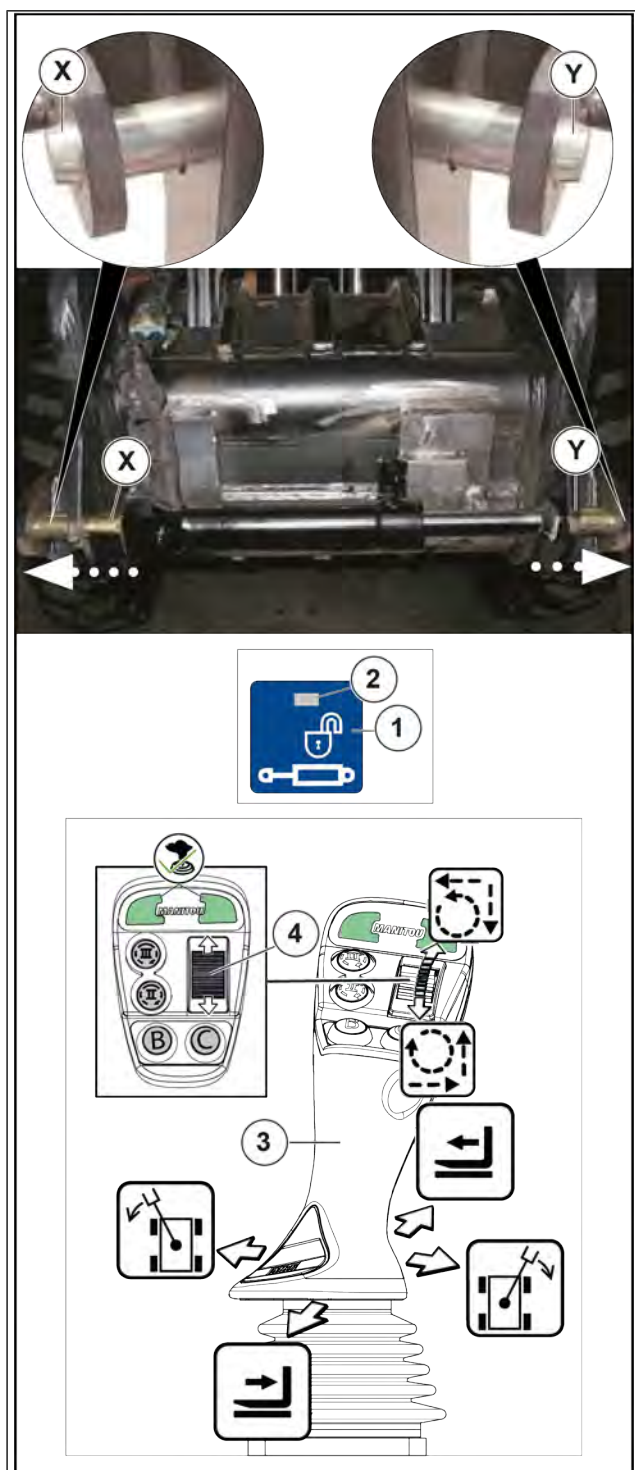


Figure 174: Hydraulic block and description of attachment controls

## 2.8.5 ENGINE ECO STOP

This feature aims to stop the engine to limit consumption.

This feature is possible if all the following conditions are met within a time frame defined by the operator.

- Engine on
- Operator not seated

- Regeneration not enabled
- Brake engaged
- Water temperature at 40°C (104°F)
- Cabin controls (remote control feature not enabled)

### TIMER ADJUSTMENT


Using the display and the “HMI” navigator:


1. access the “SETTING” page (1),
2. select the “System” submenu (2),
3. select the engine “ECO STOP” feature (3),
4. set the timer to between 30 seconds and 20 minutes (in 30-second steps) on the bar appearing on the display (4). Adjust the time using the keys (+/-).
5. To confirm the setting, select “SAVE” (5).


### OPERATION

#### ⚠ WARNING

The engine “ECO STOP” feature does not replace vehicle stoppage under any circumstances. The vehicle must be stopped at the end of the job or of the work day.

The engine “ECO STOP” button  is located on the display on the “DRIVE” page.

Select or press the engine “ECO STOP” button  to enable the feature. The button (5) lights up when the feature is enabled.

 To restart, turn the ignition key to position “0”.

### 2.8.6 HYDRAULIC ATTACHMENTS CONTINUOUS OPERATING MODE

**⚠ DANGER**

This mode must only be used with an attachment requiring continuous hydraulic movement such as: sweeper, distribution bucket, mixer, sprayer, etc. Therefore it is strictly forbidden during handling and in all other cases (winch, boom, winch boom, hook, etc.).

#### USE

To activate the mode of operation for the continuous hydraulic movement of the attachment, press the key



on the armrest.

To control the hydraulic movements of the attachment, move the roller on the joystick that controls the option.

A potentiometer (2) on the "DRIVE" page on the display is used to adjust the required flow rate (from 0% to 100%) and limit the hydraulic movement of the attachment.

Use the “—” or “+” icons (1) to increase or decrease the percentage (%).




Figure 175: ECO STOP



Figure 176: Function control percentage setting


#### Activation of the mode

- Move the roller that controls the option in the direction of the desired hydraulic movement;
- press and hold the operating mode activation key ;
- release the roller that controls the option: an alarm will sound for a second to signal that the mode of operation for the continuous hydraulic movement of the attachment has been activated.
- Release the operating mode activation key

 The roller that controls the option enables the hydraulic movements of the attachment in one direction only.

### Functioning of the LED on the key



The status of the LED on the  key depends on the percentage (2) adjusted on the display:

- if the value is 0%, the LED on the key is always off;
- while the operating mode is activated, the LED on the key remains on;
- while using the mode, the LED on the key flashes.

### Mode deactivation

The operating mode is deactivated under certain conditions.

- Adjust the percentage (2) of the flow rate limitation to 0%;
- move the roller in one direction;
- open the cab door;
- disable all hydraulic movements on the joystick with



the "HMI" navigator;

- activate or deactivate the 2nd hydraulic output



on the boom head to select more movements of the attachment;

- activate the hydraulic block of the attachment



- machine alarm.

## 2.8.7 SECOND HYDRAULIC OUTLET + HYDRAULIC BLOCK OF THE ATTACHMENT

There is an electrovalve at the top of the boom which allows the exchange of several hydraulic movements of an attachment:

- Direct hydraulic line (L1 — L2)
- Second output hydraulic line (L3 — L4)
- Hydraulic line of the hydraulic attachment block (L5)

### Second output hydraulic line (L3 — L4)


To select and enable the second hydraulic output,



press the button . The button is used to

exchange the direct hydraulic line (L1 — L2) with the second output hydraulic line (L3 — L4).




The icon  on the display indicates that the second hydraulic output is available and ready for use.

### Hydraulic line of the attachment hydraulic block (L5)

To select and enable the hydraulic line of the



attachment hydraulic block (L5), press the key .

For more details on using the feature, see the section: HYDRAULIC BLOCK OF THE ATTACHMENT

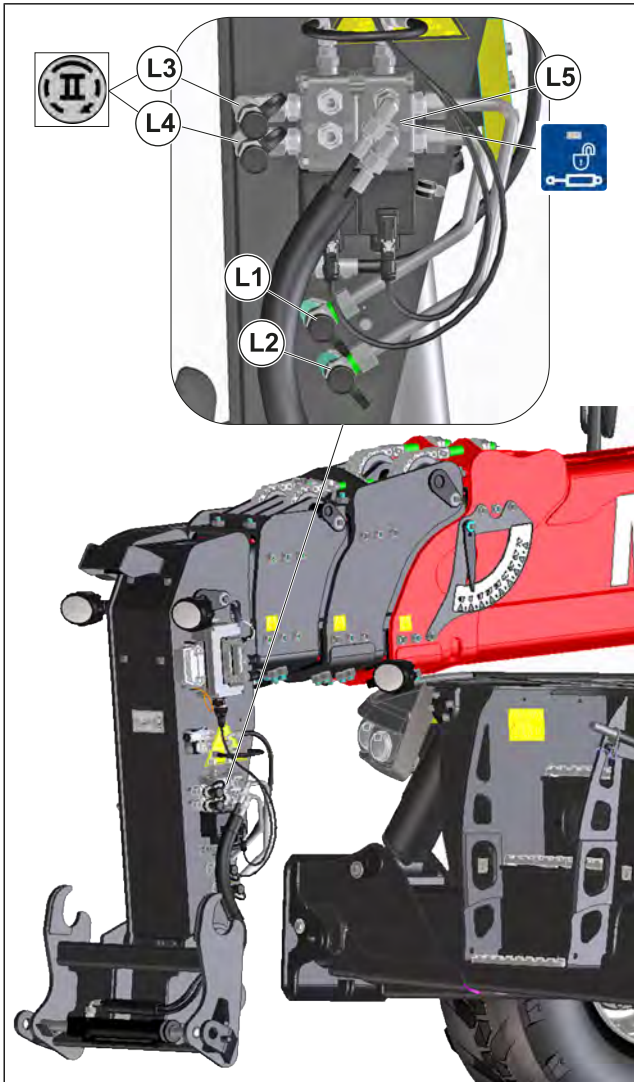


Figure 177: Second hydraulic outlet + hydraulic attachment block.

### 2.8.8 FRONT AND SIDE CAMERA SYSTEM

The machine is equipped with an optional video system which consists of two video cameras (1A-2A) and a 7" LCD monitor (3) inside the cabin.

The two cameras are installed on the machine on the sides:

1. Front (boom head) (1A).
2. Side (engine part, near the rear-view mirrors) (2A).

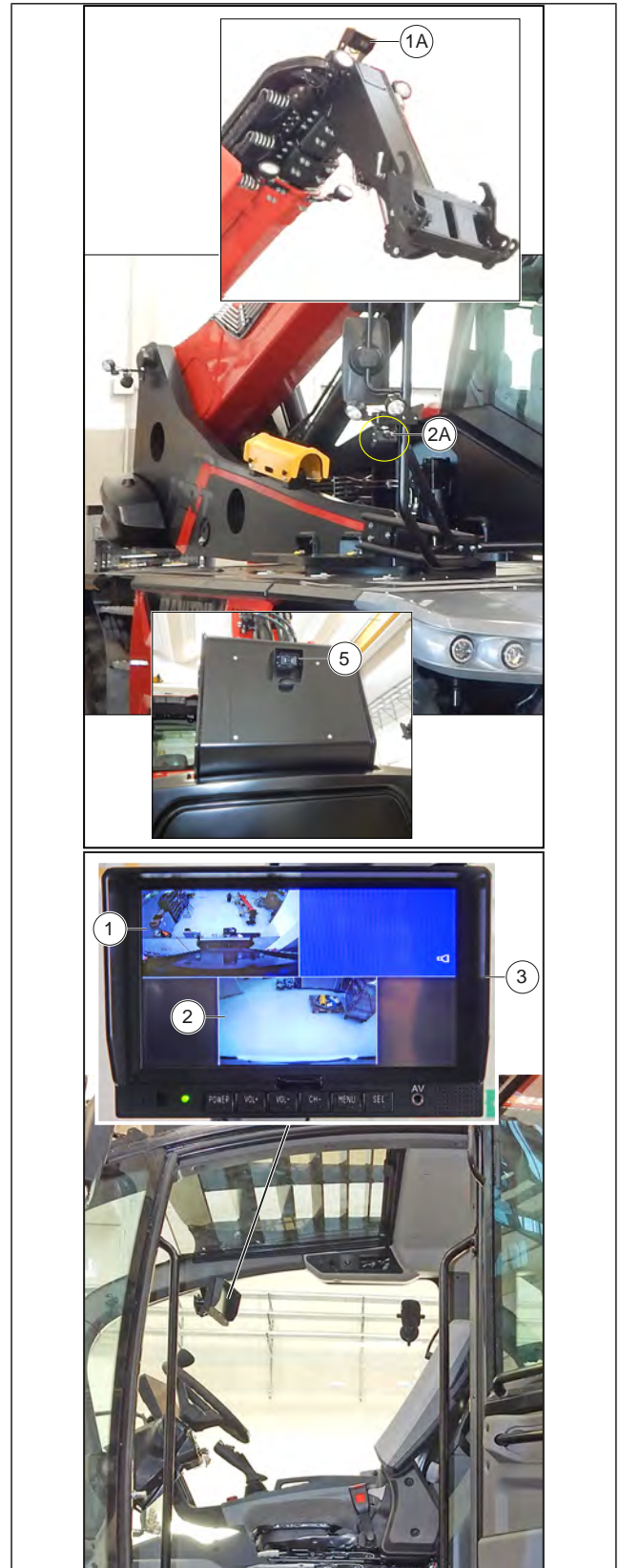


Figure 178: Front and side camera system

## 2.8.9 LED WORK LIGHTS ON THE BOOM

There are 4 LED lights (1):

- 2 work lights (1) are located at the top of the vehicle's boom.
- 2 work lights (1) are located on the vehicle's fixed boom.

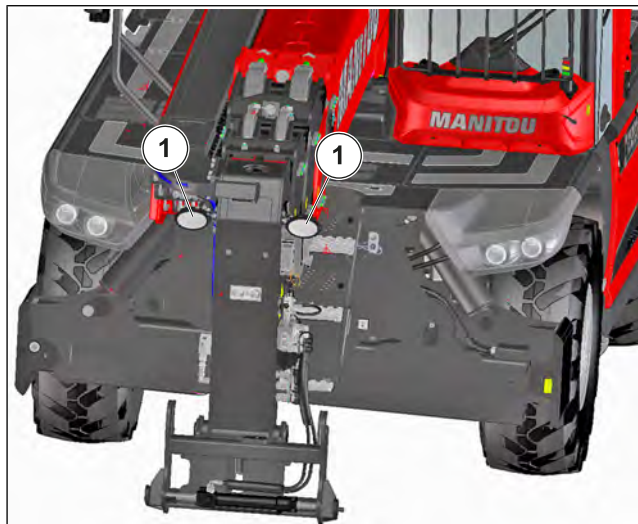


Figure 179: LED work lights at the top of the boom.

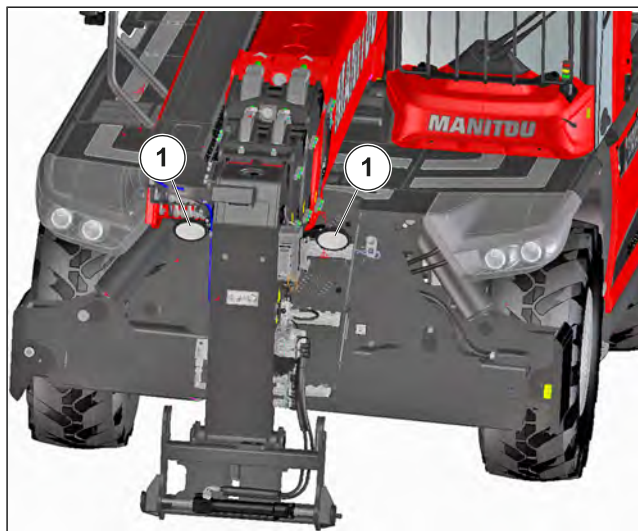



Figure 180: LED work lights on the fixed boom.

### Control

The control  that switches the work lights (1) on or off is located on the HMI display.

Briefly press the "MULTI-FEATURE" touch button



on the button bar to display the multi-feature screen.




Briefly press the touch control  to switch the work lights (1) on or off. The button lights up when the feature is enabled.



Figure 181: Multifunction screen and work light activation control.

## 2.8.10 REAR CABIN WORK LIGHTS


(no air conditioner)

There are two LED lights (1) which are located at the top of the rear of the vehicle's cabin.



Figure 182: Front and rear cabin work LED lights

### Control

The control  that switches the work lights (1) on or off is located on the HMI display.

Briefly press the "MULTI-FEATURE" touch button



on the button bar to display the multi-feature screen.


Briefly press the touch control  to switch the work lights (1) on or off. The button lights up when the feature is enabled.



Figure 183: Multifunction screen and work light activation control.

### 2.8.11 REAR CABIN WORK LIGHTS


(With air conditioner)


There are two LED lights (1) which are located at the top of the rear of the vehicle's cabin.



Figure 184: Front and rear cabin work LED lights

#### Control

The control  that switches the work lights (1) on or off is located on the HMI display.

Briefly press the “MULTI-FEATURE” touch button  on the button bar to display the multi-feature screen.

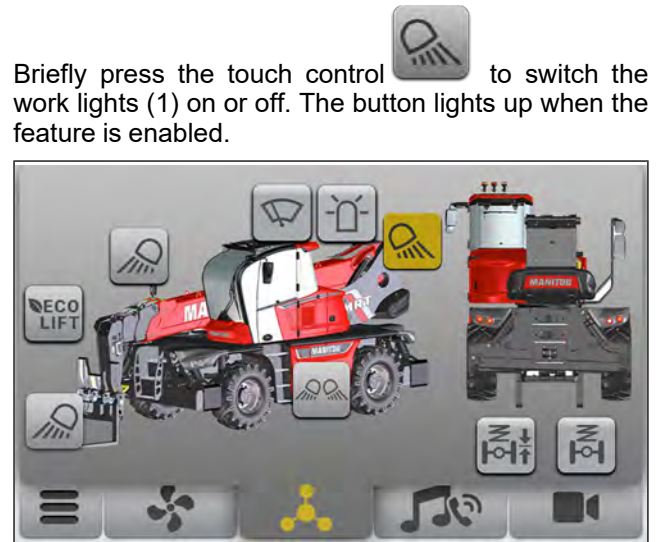


Figure 185: Multifunction screen and work light activation control.

### 2.8.12 BOOM ANGLE INDICATOR

The angle indicator (1) is positioned on the front of the boom and improves the reading of the load diagrams.

When the boom is moved up or down, the pointer on the angle indicator (1) moves to indicate the value of the boom angle in degrees.

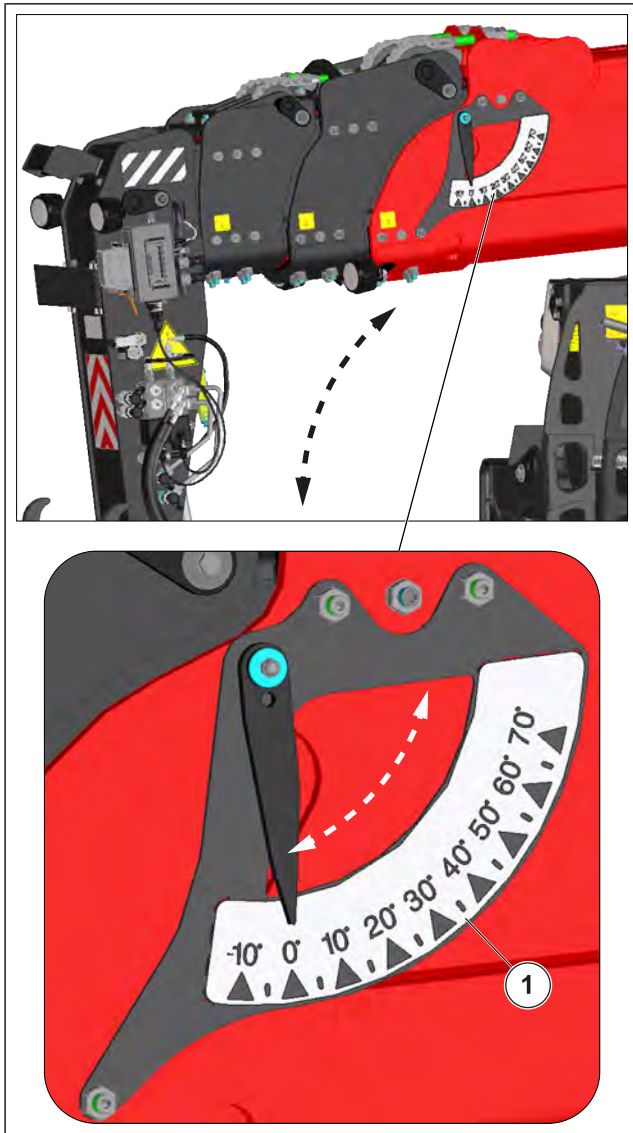


Figure 186: Boom angle indicator

### 2.8.13 INDICATION COLUMNS FOR CHECKING THE LOAD STATUS

External indicator light (1), indicating the percentage of load raised compared to the max. permitted load in these working conditions.

- Green light on: safety zone (2)
- Yellow light on (external horn activated "3"): alarm zone, load raised higher than 90% of permitted load (4).
- Red light on (external horn activated "3"): stop zone, load raised higher than 100% of permitted load (5).



Figure 187: Indication columns for checking the load status.

### 2.8.14 12V ELECTRICAL SOCKET AT THE HEAD OF THE BOOM

The 12V electrical socket (4-pole) is located on one side of the telescopic boom head (1) and allows interchangeable equipment to be electrically connected with the vehicle.

#### USE

Follow the procedure to connect the electrical system and allow the use of interchangeable equipment:

1. remove the protective cover (2) of the socket on the head of the boom (1),
2. connect the electrical system of the interchangeable equipment to the 12V socket at the head of the boom (1).
3. Get into the cab and sit in the driver's seat. Turn the engine on.
4. Press button "B" (3) on the left joystick (4) to enable the electrical connection between vehicle and equipment.
5. Move the optional roller (5) on the left joystick (4) to control the equipment.
6. Once the equipment has been used, disconnect the electrical system and remount the protective cover (2) of the 12V socket (1).

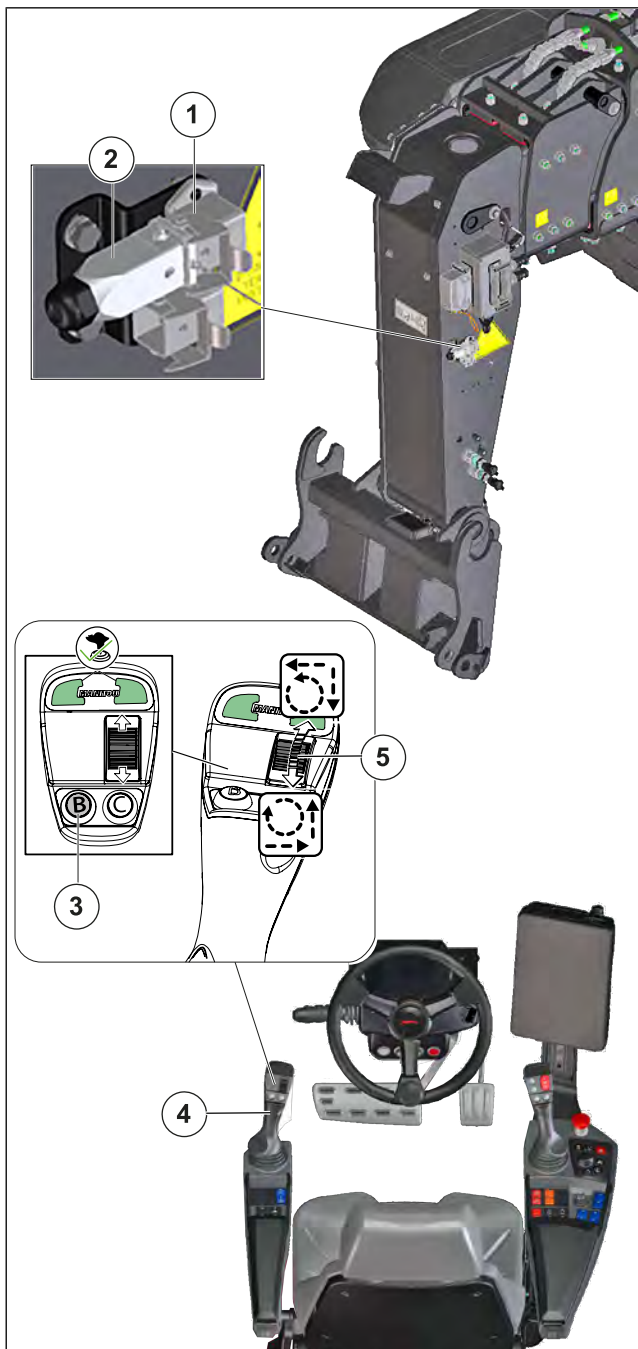


Figure 188: 12V electrical socket at the head of the boom.

- a 16A to 110V 50/60Hz industrial single-phase electric socket (2P+T) positioned at the head of the telescopic boom (1),
- an electric panel containing (2):
  - a 10A differential magneto-thermal circuit breaker (with C type tripping curve and activation current greater than or equal to 30mA) (2b);
  - a 16A industrial electric plug for connection to the electricity mains (2a);
- wiring that connects the socket at the head of the boom to the electric panel,

**CONNECTION TO THE ELECTRICITY MAINS**

STEPS:

1. Connect the electric plug (2) to the electricity mains (5),
2. connect the electrical equipment to the socket at the head of the boom (1),
3. turn the differential magneto-thermal circuit breaker (2b) to ON.
4. Press the (6) "TEST" button present on the differential magnetothermal circuit breaker.

At the end of the procedure, the electric socket at the head of the boom will be powered.

**⚠ DANGER**

Take care while connecting the electrical equipment to the socket to the head of the boom.

**⚠ DANGER**

Check the working of the differential magneto-thermal circuit breaker periodically.

**2.8.15 110V ELECTRIC SOCKET**

**⚠ DANGER**

This system is designed for being powered with a 110V 50/60Hz voltage.

The "110V electric socket" system consists of the following components:

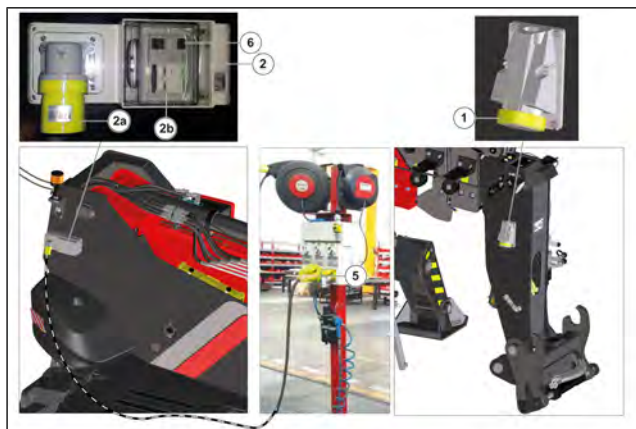


Figure 189: "110V electric socket" system

### DISCONNECTING FROM THE ELECTRICITY MAINS

Repeat the operations described in the paragraph in reverse order "Connection to the electricity mains".

### CHECKING THE WORKING OF THE DIFFERENTIAL MAGNETOTHERMAL CIRCUIT BREAKER

#### ⚠ DANGER

Check the working of the differential magneto-thermal circuit breaker periodically.

1. Connect the electric plug (2b) to the electricity mains (5),
2. connect the electrical equipment to the socket at the head of the boom (1),
3. turn the differential magneto-thermal circuit breaker (2b) to ON.

#### Positive result

the switch cuts off the electric contact; on changing the position from ON to OFF automatically, the device works correctly.

#### Negative result

the switch does not interrupt the electric contact. In this case the differential magnetothermal circuit breaker does not work correctly. Contact the dealer for repair

#### ⚠ DANGER

if the previous test did not give a positive result, DO NOT use any electrical equipment connected to the socket at the head of the boom.

## 2.8.16 220V ELECTRIC SOCKET

### ⚠ DANGER

This system is designed for being powered with a 230V 50/60Hz voltage.

The "220V electric socket" system consists of the following components:

- a 16A to 230V 50/60Hz industrial single-phase electric socket (2P+T) positioned at the head of the telescopic boom (1),
- an electric panel containing (2):
  - a 10A differential magneto-thermal circuit breaker (with C type tripping curve and activation current greater than or equal to 30mA) (2b);
  - a 16A industrial electric plug for connection to the electricity mains (2a);
- wiring that connects the socket at the head of the boom to the electric panel,

### CONNECTION TO THE ELECTRICITY MAINS

#### STEPS:

1. Connect the electric plug (2) to the electricity mains (5),
2. connect the electrical equipment to the socket at the head of the boom (1),
3. turn the differential magneto-thermal circuit breaker (2b) to ON.
4. Press the (6) "TEST" button present on the differential magnetothermal circuit breaker.

At the end of the procedure, the electric socket at the head of the boom will be powered.

### ⚠ DANGER

Take care while connecting the electrical equipment to the socket to the head of the boom.

### ⚠ DANGER

Check the working of the differential magneto-thermal circuit breaker periodically.

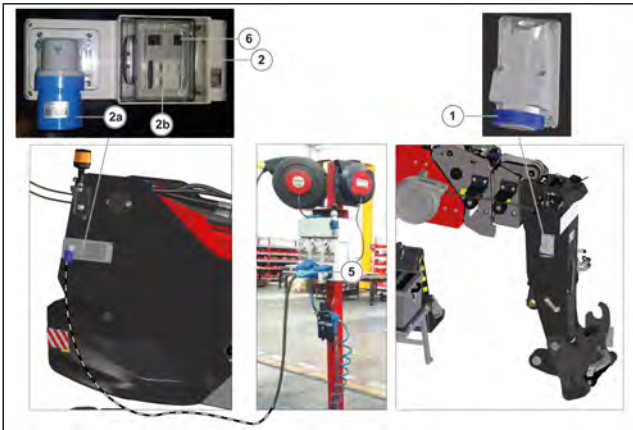


Figure 190: "220V electric socket" system

### DISCONNECTING FROM THE ELECTRICITY MAINS

Repeat the operations described in the paragraph in reverse order "Connection to the electricity mains".

### CHECKING THE WORKING OF THE DIFFERENTIAL MAGNETOTHERMAL CIRCUIT BREAKER

**⚠ DANGER**

Check the working of the differential magneto-thermal circuit breaker periodically.

1. Connect the electric plug (2b) to the electricity mains (5),
2. connect the electrical equipment to the socket at the head of the boom (1),
3. turn the differential magneto-thermal circuit breaker (2b) to ON.
4. Press the (6) "TEST" button present on the differential magnetothermal circuit breaker.

#### Positive result

the switch cuts off the electric contact; on changing the position from ON to OFF automatically, the devices works correctly.

#### Negative result

the switch does not interrupt the electric contact. In this case the differential magnetothermal circuit breaker does not work correctly. Contact the dealer for repair

**⚠ DANGER**

if the previous test did not give a positive result, **DO NOT** use any electrical equipment connected to the socket at the head of the boom.

### 2.8.17 REAR ELECTRICAL SOCKET 7 POLES 24V FOR TRAILER

The 24V 7-pole socket (1) with protective door (2) is installed on the rear of the vehicle.

This socket (1) is used for the electrical connection between the towing vehicle and a trailer with 24V electric system.



Figure 191: 24V 7-pole electrical socket.

### 2.8.18 PREHEATING ELEMENT FOR ENGINE'S COOLANT FLUID 220 V

Enables the engine block to be kept warm during prolonged periods of stoppage and thus improves engine starting.

#### CHARACTERISTICS OF THE PREHEATING SYSTEM

Description	Data
Power	1000 W
Rated range of power	220-240 V ; 50-60 Hz
Current consumption	4,5 A
Isolation	Class 1 equipment
Equipment connectable only to Earth-Earth (TT) or Earth-Neutral (TN) circuits	

#### ENVIRONMENTAL CONDITIONS FOR USE

- Maximum ambient temperature for using preheating: +25°C
- Pollution level 2

## CONDITIONS FOR CONNECTION

The preheating system should not be used for an external ambient temperature higher than + 25°C.

It is essential that the power supply to the preheating system is:

- Effected with a cable that conforms to the installation standards in force and contains a protective earth conductor.
- Contains an appropriate isolation system.
- Incorporate an appropriate safety system against short circuits (fuses or circuit breaker) and a differential circuit breaker with 30 mA sensitivity.

### **⚠ WARNING**

#### **Risk of component failure**

Supply with one phase and neutral in order to have mono-phase 110 V AC.

Do not supply the heater with two phases taken from the 3-phase network AC or the resistance and the thermostat will burn.

### **⚠ WARNING**

#### **Risk of short-circuit**

Danger of short circuit and cable damage.

The cable connection must be carried out in sealed casing to prevent liquids from entering the inside of the heater (drawing along the wires within its sheath) causing short-circuits.

### **⚠ WARNING**

#### **Risk of damage to preheating system**

Damage of components.

Do not connect or disconnect the preheating system to the electrical power supply line while the engine is on.

## USE OF THE PREHEATING SYSTEM

### **System switch on procedure**

1. Switch off the engine of the machine.
2. Open the engine bonnet.
3. Connect the plug (B) of the supply cable (1) to the heater socket 2.
4. Connect the plug (A) of the supply cable (1) to the electrical power supply line.

Now the heater is switched on and it keeps warm the engine's water cooling.

### **System switch off procedure**

1. Disconnect the plug (A) of the supply cable (1) to the electrical power supply line.
2. Disconnect the plug (B) of the supply cable (1) to the heater socket 2.
3. Close the engine bonnet.

Now the heater is switched off and it is possible to switch on the machine engine.

## MAINTENANCE OF THE PREHEATING SYSTEM

Preheating element for engine's water cooling does not need of maintenance.

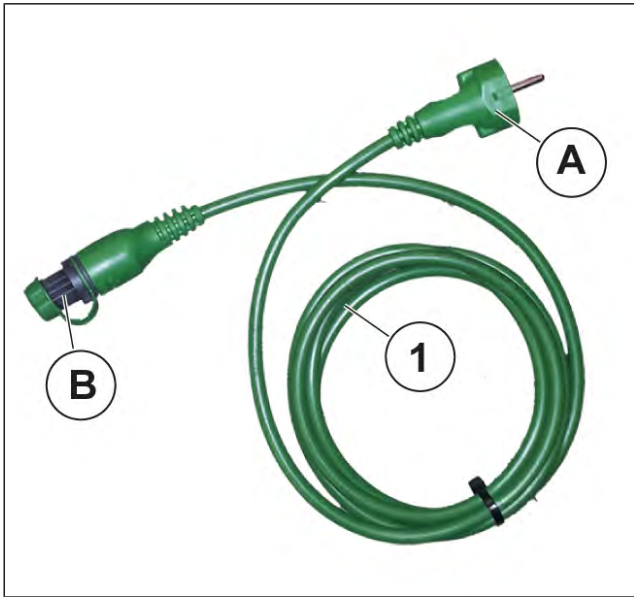


Figure 192: Preheating system cable



Figure 193: Preheating system connector

### 2.8.19 PREHEATING SYSTEM FOR HYDRAULIC OIL 220 V

Enables the hydraulic oil in the tank to be kept warm during prolonged periods of stoppage.

## CHARACTERISTICS OF THE PREHEATING SYSTEM

Description	Data
Absorbed rated power	350 W <sup>1</sup>
Supply	220-240 V ; 50-60 Hz
Absorbed current	1,6 A <sup>1</sup>
Operating temperature	45 °C ±10%
Max. operating temperature	80 °C ±10%
Isolation class	Class 1
Equipment connectable only to Earth-Earth (TT) or Earth-Neutral (TN) circuits.	



<sup>1</sup> The supply time of the heating resistance and consequently the current consumption, are proportional to the "mass" to be heated and the ambient temperature.

The preheating system hydraulic is made of:

- Aluminum shell
- Shaped electric resistance
- Adjustable thermostat
- Electrical connections

The electrical resistance begins to heat the aluminum shells, which, placed in contact with the hydraulic oil tank, dissipate the heat.

When the temperature is reached (set at ± 45° C), the thermostat intervenes and cuts off power to the resistance. As the temperature falls, the thermostat supplies again the resistance, continuing this cycle until there is mains power supply, maintaining a temperature more or less constant, the parts to be heated.

## CONDITIONS FOR CONNECTION

The preheating system should not be used for an external ambient temperature higher than + 25 °C.

It is essential that the power supply to the preheating system is:

- Effected with a cable that conforms to the installation standards in force and contains a protective earth conductor.
- Contains an appropriate isolation system.
- Incorporate an appropriate safety system against short circuits (fuses or circuit breaker) and a differential circuit breaker with 30 mA sensitivity.

### ⚠ WARNING

#### Risk of damage to preheating system

Damage of components.

Do not connect or disconnect the preheating system to the electrical power supply line while the engine is on.

- Switch off the machine.
- Open the hood.
- Connect the "220 V socket" (a) to a power source to access the heater.

### ⚠ WARNING

#### Risk of component failure

Do not supply the two-phase resistor taken from the 380 VAC three-phase mains, otherwise the resistor and thermostat would burn out.

Feed with a phase cable and the neutral conductor to obtain a single-phase current of 230 VAC.

### ⚠ WARNING

#### Risk of short-circuit

Danger of short circuit and cable damage.

The cable connection must be carried out in sealed casing to prevent liquids from entering the inside of the heater (drawing along the wires within its sheath) causing short-circuits.



Figure 194: Preheating system plug

### 2.8.20 WINDSHIELD PROTECTION GRILLE

A protection grille is installed on the windshield of the cab to protect against even the most precarious of falling materials without compromising its wide field of vision.



Figure 195: Windshield protection grille.

### 2.8.21 WINDSHIELD PROTECTION GRILLE WITH ULTRA PANORAMIC VIEW ROOF

A protection grille is installed on the windshield of the cab to protect against even the most precarious of falling materials without compromising its wide field of vision.



Figure 196: Windshield protection grille with ultra panoramic view roof.

### 2.8.22 INTERIOR REAR-VIEW MIRROR

The rear-view mirror (1) is located inside the cab and allows the driver to check for any obstacles behind the vehicle.

The rear-view mirror is adjusted manually.

**⚠ WARNING**

Before starting to move the vehicle, drivers must adjust the mirror in order to obtain the best rear view according to their driving position.



Figure 197: Interior rear-view mirror

### 2.8.23 ROAD CIRCULATION

Comply with the road regulations in force in the country in which the vehicle is being driven.

There are optional solutions where required. Contact your dealer.

#### RECTANGULAR ORANGE RETRO-REFLECTORS

The retro-reflectors (1) are visual signaling devices positioned on the right and left side of the vehicle.

#### ROUND RED RETRO-REFLECTORS

Red retro-reflectors (2) are visual signaling devices positioned on the rear of the vehicle.

#### SPEED LIMIT DISK

The speed limit disks (3) indicate the maximum speed allowed depending on the type of vehicle and the country's traffic code. The disks may be in different colors and positions on the vehicle depending on the country in which it is being driven (see examples in Figure 1).

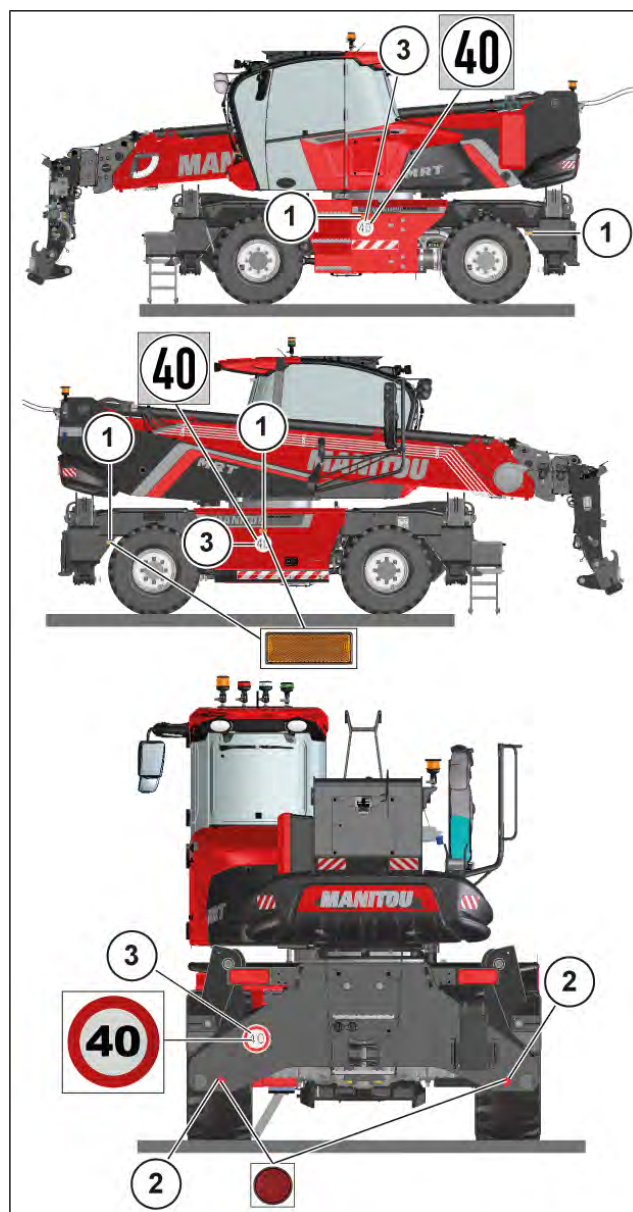


Figure 198: Retro-reflectors and speed limit disk (examples).

### 2.8.24 PORTABLE POWDER FIRE EXTINGUISHER

**⚠ DANGER**

The fire extinguisher must be checked according to the time frames governed by each country in which the vehicle operates (once a year in the majority of cases).

If the fire extinguisher is used, it will need to be refilled by authorized personnel.

The portable powder fire extinguisher (1) is designed to extinguish fires involving liquids, flammable gases and electrical components.

The portable powder fire extinguisher (1) is located in its stand on the vehicle.

CHARACTERISTICS	
Fire classes	34A - 233 BC
Extinguishing agent	ABC powder
Ministerial approval	MED / 0497 / 015 / 07
Nominal charge	6 kg ( )
Total weight	9.5 kg ( )
Test pressure	26 bar ( )
Bursting pressure	>55 bar ( )
Operating pressure	20° 14 bar ( )
Discharge time	9.5 sec.

Procedure in the event of a fire:

1. take the fire extinguisher (1) out of its stand,
2. remove the safety pin (2),
3. follow the instructions provided on the fire extinguisher (3).



Figure 199: Portable powder fire extinguisher (example).

### 2.8.25 INCREASED SUPPORT PLATFORMS FOR STABILIZERS

**⚠ DANGER**

#### Risk of crushing

Beware of the risk of pinching or crushing limbs when manually adjusting the platforms. Move away from the platforms after placing them on the ground and only then lower the stabilizers onto the platforms.

To operate in full safety and avoid hazardous situations in all working environments, the machine can be stabilized by placing a wider foot platform under each stabilizer, which will better distribute the pressure on the ground and reduce the risk of the stabilizer foot sinking.

Before starting a work cycle with the machine stabilized, always check the surface of the soil, which must not be:

- slippery,
- yielding,
- bumpy.

The platforms (1) are inserted into pockets on the vehicle and locked by pins (2) with safety pins (3). Remove the pins (2) and the safety pins (3) to free the platforms (1) from their supports.

Follow the procedure for using the platforms:

1. open and lower each vehicle stabilizer towards the ground at a distance of approximately 200 mm (7.8 in).
2. Take the platforms (1) from the vehicle,
3. hold the platforms (1) with the handles (4) to place them under the 4 stabilizer feet. Move away from the vehicle's operating area.
4. Slowly lower the stabilizers onto the platforms (1) and completely stabilize the vehicle.

To replace the 4 platforms (1) in the pockets on the vehicle, follow the procedure for using the platforms in reverse.

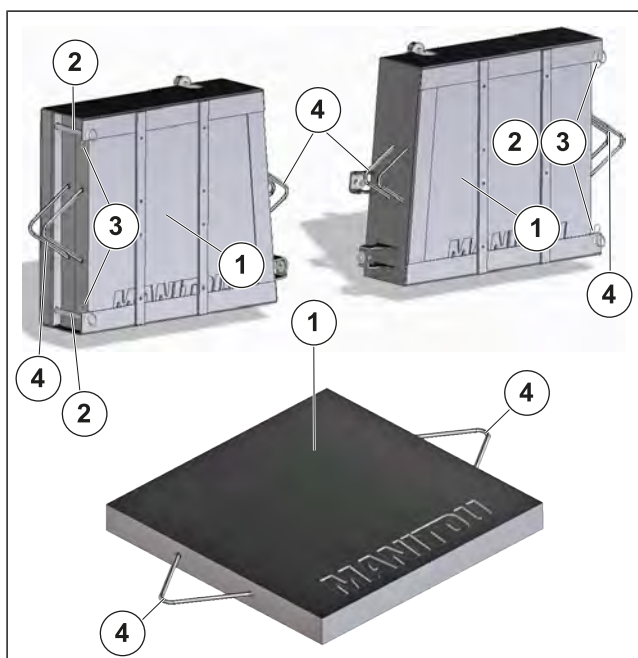


Figure 200: Increased support platforms for stabilizers.

## 2.8.26 WHEEL CHOCKS

**▲ DANGER**

### Risk of pinching or crushing

Beware of the risk of pinching or crushing limbs when opening or closing and installing wheel chocks.

Wheel stop to block the stationary vehicle on flat or sloping ground.

It increases safety during vehicle loading and unloading operations or during vehicle maintenance or repair.

Follow the procedure for using wheel chocks:

1. Remove the 2 wheel chocks (1) from their housing on the vehicle.
2. Open the wheel chocks (1) and insert them under the wheels to block their movement.

To replace the 2 wheel chocks (1) in the pockets on the vehicle, follow the procedure for using the wheel chocks in reverse.



Figure 201: Wheel chocks.

## 2.8.27 TOOL BAG FOR WHEEL DISASSEMBLY

### TOOL BAG FOR DISASSEMBLING THE WHEEL

The tool bag (4) contains three tools for unscrewing and screwing the nuts that lock the wheel to the axle:

- a sliding "T" wrench (1),
- an extension for 3/4" socket wrench (2),
- a 3/4" 32 mm hexagon socket wrench (3).

Pair the three tools (5) to obtain the 32 mm hex socket wrench. Unscrew the wheel nuts.



For more details on wheel disassembly/assembly, refer to the "instruction manual, occasional maintenance chapter, paragraph: Wheel replacement".

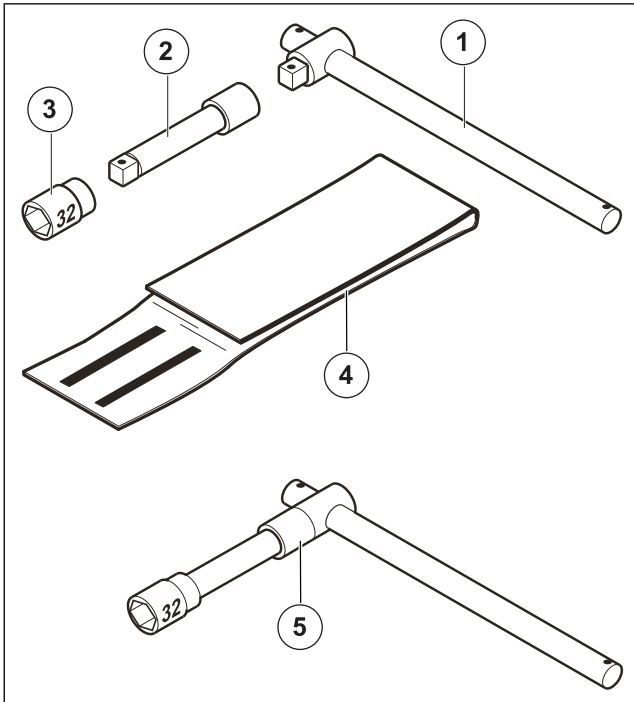


Figure 202: Tool bag for disassembling the wheel.

### 2.8.28 TOOLBOX

The machine is equipped with a toolbox (1).

To access the tools, unlock the door of the box with the handle (2) and lift the door (3).

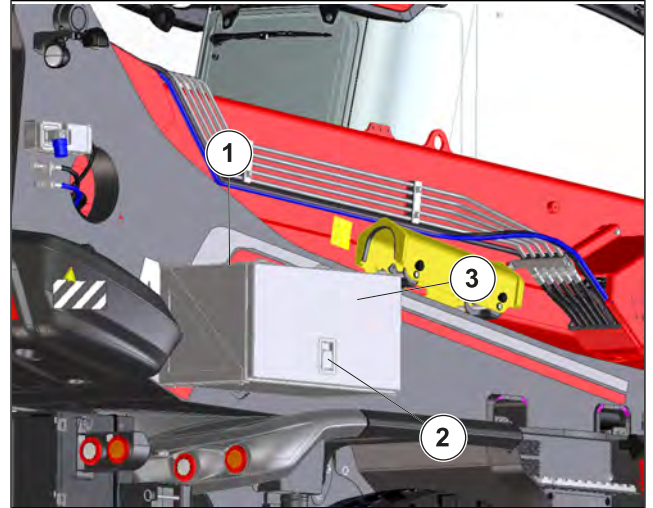


Figure 203: Toolbox.



## 3. USE OF THE MACHINE

### 3.1. BEFORE USING THE MACHINE

#### 3.1.1 PRE-USE INSPECTION CHECKLIST

##### BEFORE STARTING THE VEHICLE

- Carry out daily maintenance.
  - Make sure there are no hydraulic oil leaks or leaks from the cylinder block valves, connecting fittings, and the rear deck block valve.
- Make sure the driver's cab is clean, especially the floor and mat.
- Check that no moving objects disturb the control of the vehicle.
- Check whether the lights, headlights and windshield wipers are working properly and their condition.
- Check if the rear view mirrors are in good condition and adjusted properly.
- Check the effectiveness of the acoustic signal.

##### CORRECT POSITION IN THE DRIVER'S SEAT

- No matter how much experience he has, the driver should familiarize himself with the position and use of all control and command tools before putting the vehicle into service.
- Wear clothes suitable for driving the vehicle, avoid fluttering clothes.
- Take protective equipment suitable for the work to be done.
- Prolonged exposure to a loud noise can cause hearing loss. To protect yourself from annoying noises, the use of hearing protection is recommended.
- Always get in and out of the vehicle with access to the driver's cab in front of you and use the handles provided. Do not jump off the vehicle to get off.
- Always be careful when using the vehicle, do not listen to the radio or music with earphones or headphones.
- Never drive with wet or greasy hands or shoes.
- For optimal comfort, adjust the seat to your liking and get in the right position in the driver's cab.

### DANGER

**Under no circumstances should seat adjustments be made while the vehicle is in motion.**

- The driver must always remain in his normal position in the driver's cab: he is forbidden to stretch his arms, legs and in general any part of his body outside the driver's cab of the vehicle.
- The use of the seat belt is mandatory and must be adjusted to the height of the operator.
- The control elements must never be used improperly (example: as a support to get on or off the vehicle, as a clothes hanger, etc.).
- If the control elements are equipped with a forced march device (lever block), it is forbidden to leave the driver's cab without positioning the controls on "neutral".
- It is forbidden to carry passengers in the vehicle or in the driver's cab.

##### VISIBILITY

- The safety of the people in the maneuvering area of the vehicle, of the vehicle itself and of the operator, depend on the operator's ability to see the working area of the vehicle in any circumstance and constantly.
- This vehicle has been designed to allow the operator to always have good visibility (direct or indirect via rear-view mirrors) of the work area when traveling with the truck unladen and the boom in the transport position.
- If the volume of the load restricts visibility in front, special precautions must be taken:
  - Reverse to destination.
  - Tidy up the site.
  - Help from a someone (positioned outside the vehicle's range of operation) to direct the maneuver, ensuring that you can always clearly see this person.
  - In any case, avoid reversing for too long.
- With some special attachments, it may be necessary to keep the boom in the raised position to move the vehicle. In this case, the visibility from the right side is limited and special precautions must be taken:
  - Tidy up the site.

- Help from a someone (positioned outside the vehicle's range of action) to direct the maneuver.
- Replacement of a hanging load with a pallet load.
- In all cases where the visibility of the route is insufficient, get help from someone (positioned outside the vehicle's range of operation) to direct the maneuver, making sure that you can always clearly see this person.  
Keep all elements to improve visibility in perfect working order, correctly adjusted and clean: windshields and windows, windshield wipers and washers, headlights and work lights, rear-view mirrors.

### 3.1.2 VISIBILITY

Our products comply with the European standard EN 15830 on operator visibility.

Follow the instructions to optimize the visibility of the operator in the surrounding environment.

#### DESCRIPTION AND ADJUSTMENT OF REARVIEW MIRRORS

(Depending on vehicle model or equipment)

1. Main left rearview mirror
2. Secondary left rearview mirror
3. Interior rearview mirror
4. Right side view mirror
5. Secondary right side rearview mirror
6. Primary right side rearview mirror
7. Rear camera
8. Operator

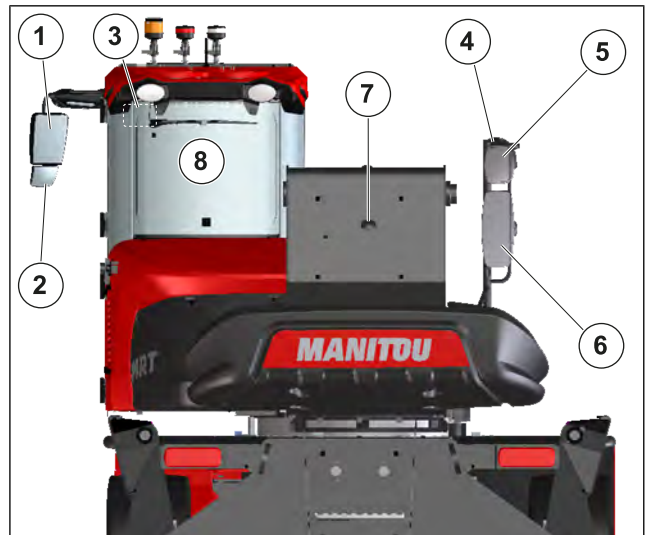


Figure 204: Rearview mirrors and rear camera

#### How to adjust mirrors (Depending on vehicle model or equipment)

Position the vehicle on a horizontal surface and turn it off.

Fully retract and lower the telescopic boom.

Adjust the mirrors manually (or electrically from the cabin) following the references and angles of visibility (colored), as shown below. Respect the angles of visibility depicted and identified for each mirror with a different color and shape.

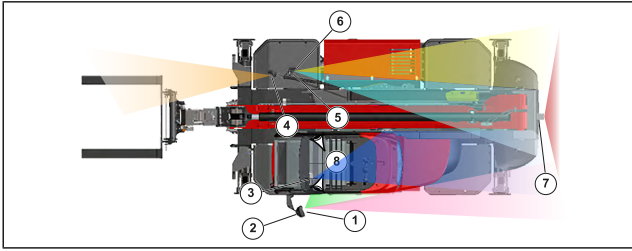


Figure 205: Visibility of mirrors and rear camera

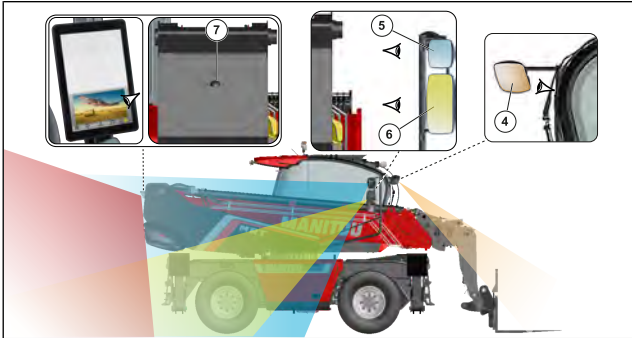


Figure 206: Mirror visibility (right side) and rear camera

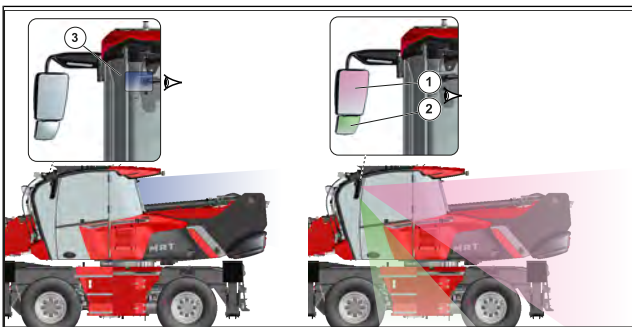



Figure 207: Mirror visibility (left side and cabin interior)

### 3.1.3 AREA AROUND THE VEHICLE

Carry out a general inspection around the vehicle:

- Leak or stain of liquid on the ground.
- Presence of foreign objects on the vehicle and in the cabin.
- Fixing and locking of the attachment.
- Fixing and adjusting the rear view mirrors.
- Tire condition to identify cuts, bumps, wear, etc.

 Observe the instructions for the operator.

#### Cleaning the vehicle

- Cleaning of the headlights and rear view mirrors.
- Excess dirt or accumulation of material (e.g. straw, flour, sawdust, organic waste, etc.).
- Every day and according to the conditions of use and the environment, the operator must ensure that the vehicle is clean.

- The accumulation of flammable materials (e. g. straw, flour, sawdust, organic waste, etc.) and fuel or lubricant leaks must require special attention, as they greatly increase the risk of fire.
- A regular inspection of the entire vehicle, especially the engine compartment and the central part of the chassis, is necessary to establish the frequency of cleaning, in order to avoid potential accumulation or loss of material.

### 3.1.4 FILLING THE FUEL TANK

- Keep the fuel tank as full as possible to minimize condensation due to atmospheric conditions.

**⚠ DANGER**

#### Danger of fire.

**Never fill up while the engine is running.**

Do not smoke or approach with an open flame during filling operations or when the tank is open.

- If necessary, add diesel fuel.
- Remove the cap (1).
- Fill the tank with clean and filtered diesel fuel through the filling orifice.
- Put the cap back on.
- Look to make sure that there are no leaks on the tank or pipes.


 A lockable tank cap is available as an option



Figure 208: Filling the fuel tank

### 3.1.5 FILLING THE "DEF" TANK

(diesel exhaust fluid (adblue)).

## ⚠ WARNING

### Danger of corrosive substances

The diesel emissions additive is a corrosive product. Protect the bodywork and wear personal protective equipment (gloves and goggles). The level of the diesel exhaust fluid (adblue) is important, an operation with the tank empty or with little fluid can compromise the performance of the three-phase motor.

If necessary, add diesel exhaust fluid (adblue).

- Remove the cap (1).
- Slowly fill the tank to the bottom of the fill chute.
- Always maintain a good level to limit the alteration of the product.
- Put the cap back on.

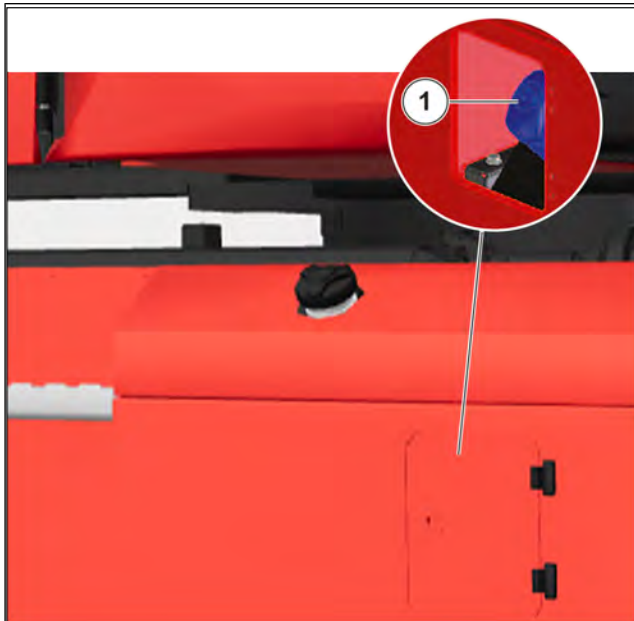


Figure 209: Filling the "DEF" tank



A lockable tank cap is available as an option

### "DEF" (diesel exhaust fluid (adblue)) quality

The quality of the diesel exhaust fluid (adblue) can be measured with the aid of a refractometer; the diesel exhaust fluid (adblue must comply with ISO 22241-1 with 32.5% urea solution.

Refractometer (MANITOU reference: 959709).

### "DEF" (diesel exhaust fluid (adblue)) storage

Up to 4 months of non-use of the forklift: check the quality of the diesel exhaust fluid (adblue) with the aid of a refractometer.

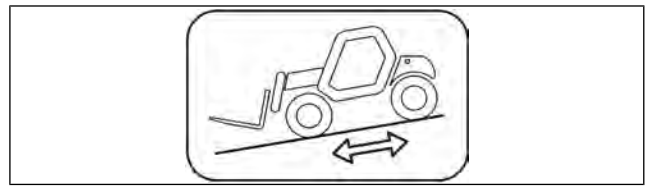
Beyond 4 months: change the diesel exhaust fluid (adblue). Empty and rinse the tank.

## 3.1.6 WORK AREA INSPECTION

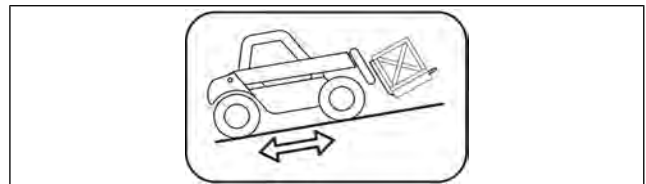
- Follow the site's safety rules.
- During handling operations, make sure that nothing or no one obstructs the maneuvering of the vehicle and the load.
- Do not authorize anyone to approach the maneuvering area of the vehicle or to pass under the load.

Driving on a longitudinal slope:

- Advance and brake smoothly.
- Movement when unladen: forks or attachment facing downhill.



- Movement with load: forks or attachment facing uphill.



Consider the dimensions of the vehicle and the load before engaging a narrow or low passage.

Never engage a loading gangway without having checked:

- That it is correctly positioned and locked.
- That the element to which it is connected (wagon, truck, etc.) cannot move.
- That it is foreseen for the total weight of the laden vehicle.
- That the gangway is designed for the overall dimensions of the vehicle.
- Never use a gangway, a platform or a freight elevator without being sure that they are correctly foreseen for the weight and dimensions of the laden vehicle, and without having checked that they are in good condition.
- Pay the utmost attention to: loading docks, excavations, scaffolding, unstable ground, wells.
- Check the stability and hardness of the ground under the wheels and/or stabilizers before lifting the load or extending the boom with the load. If necessary, add a suitable wedge under the stabilizers.
- Verify that the scaffolding, loading platform, stack or ground can support the load.

- Never stack loads on uneven ground as they may tip over.

## ⚠ DANGER

### Resting hazard

There is a risk of support if the load or the attachment remains on a structure for a long time due to the descent of the boom when the oil in the jacks cools.

Regularly check the distance between the load or attachment and the structure, readjust if necessary.

If possible, use the vehicle with an oil temperature as close as possible to ambient temperature.

When working near overhead power lines, check that the safety distance between the vehicle's working area and the power line is sufficient.

## ⚠ DANGER

### Electrocution hazard

There is a risk of electrocution or serious accident when working or parking the vehicle too close to electrical wiring.

You need to inquire with your local electricity supply company.

In case of strong wind, do not proceed with handling: risk of compromising the stability of the vehicle and the load, especially if this is exposed to strong wind.

Prevent the risk of fire associated with use in a dusty and flammable atmosphere (e.g. straw, flour, sawdust, organic waste, etc.).

## 3.2. ENTER THE CABIN

### 3.2.1 GETTING IN AND OUT OF THE VEHICLE

## ⚠ WARNING

The vehicle is equipped with two ladders (front and rear) that allow access to the walkable surface above the vehicle's undercarriage. The latter must only be used during maintenance operations to access the walkable surface.

It is not allowed to use the front or rear ladder to access the vehicle cabin.

## ⚠ WARNING

To get in and out of the vehicle, use the access ladder located on the left side of the vehicle (fuel tank area).

The telehandler is equipped with access steps (1) and two handles (2) which are located inside the cabin to facilitate the operator's entry and exit from it.



Figure 210: Getting in and out of the vehicle

### 3.2.2 GETTING INTO THE VEHICLE

## ⚠ DANGER

#### Risk of falling or slipping

Always get on and off with your face facing the vehicle, always maintaining "three-point" contact, i.e. both feet and one hand or both hands and one foot.

Before getting on, remove oil and mud from the soles of the shoes and from the steps.

1. Fully open the cabin door.

2. Keep your hands free (do not hold tools).
3. Use the specially prepared holding points and steps.
- 4.

### **⚠ DANGER**

Do not cling to the steering wheel or other controls.  
Do not use the tire as a step.

Get on with your face facing the vehicle, always maintaining “three-point” contact, i. e. both feet and one hand or both hands and one foot.

### 3.2.3 GETTING OUT OF THE VEHICLE

### **⚠ DANGER**

#### Risk of falling or slipping

Always get on and off with your face facing the vehicle, always maintaining “three-point” contact, i.e. both feet and one hand or both hands and one foot.

Before descending, remove oil and mud from the soles of the shoes and from the steps.

1. Fully open the cabin door.
2. Keep your hands free (do not hold tools).
3. Use the specially prepared holding points and steps.
- 4.

### **⚠ DANGER**

Don't jump from the cabin.  
Do not cling to the steering wheel or other controls.  
Do not use the tire as a step.

Get off with your face facing the vehicle, always maintaining “three-point” contact, i. e. both feet and one hand or both hands and one foot.

5. At the end of the steps, before placing your foot on the ground, check that the surrounding area provides a stable foothold for the foot and is free from objects or substances that could cause loss of balance and subsequent fall.

## 3.3. TURNING THE MACHINE ON AND OFF

### 3.3.1 STARTING THE MACHINE

#### Starting the vehicle

##### Safety rules

The vehicle can only be started or maneuvered when the driver is in the driver's seat, with the seat belt fastened and adjusted.

- Do not tow or push the vehicle to start it.

### **⚠ DANGER**

#### Risk of serious transmission damage

This maneuver could cause serious damage to the transmission.

Put the gear in neutral position if you need to tow the vehicle.

#### Recommendations

- Verify that the reverse gear lever is in idleoff.
- Turn the ignition key to position I to allow electrical contact.
- Check the fuel level on the gauge.
- Turn the ignition key to position II to allow preheating and wait 15 seconds. (If required by environmental conditions).
- Do not activate the starter for more than 15 seconds, and allow it to preheat for 10 seconds between all attempts.
- Press the accelerator and turn the ignition key fully, the engine should start. Release the ignition key and let the engine run at low speed.
- Before operating in very cold climatic conditions, wait for the heat engine and hydraulic systems to warm up properly.
- Look at all control instruments immediately after starting, with the engine warm, and at regular intervals during use, in order to quickly identify and resolve any faults.
- If any of the instruments indicates a fault, stop the engine and carry out the necessary operations right away.

### 3.3.2 TURNING OFF THE VEHICLE

#### Stopping the vehicle

##### Safety rules

- Before stopping the vehicle after an intense job, leave the vehicle on to allow the coolant and oil to lower the temperature of the mechanical, hydraulic and/or electrical components.

This precaution must be strictly observed in the case of frequent stops, otherwise the temperature of some parts would increase considerably.

- Never leave the ignition key in the vehicle without the driver.
- When the vehicle is stopped, set the forks or the attachment on the ground, and put the direction selector in the "neutral" position.
- Activate the parking brake.
- If the driver has to leave the driver's cab, even temporarily, set the parking brake and put the gearbox lever in "neutral".
- Make sure the vehicle is parked in such a way as not to impede traffic and at least one meter away from the railroad tracks.
- If the vehicle must remain parked for a long period of time, protect it from bad weather, particularly if the temperature falls below freezing (check the antifreeze level), close the rear window, lock the cabin door and the right engine cover.

### Recommendations for stopping

- Park the vehicle on level ground or with a gradient of less than 15%.
- Place the direction selector on the "neutral".
- Activate the parking brake.
- Fully retract the boom.
- Rest the forks or attachment flat on the ground.
- Turn off the engine.
- Remove the ignition key.
- Check that the door is locked and that the rear window and engine cover are also closed.

Before leaving the driver's seat, make sure you have carried out all the vehicle stopping operations correctly.

## 3.4. USE OF ATTACHMENTS

### 3.4.1 SAFETY RECOMMENDATIONS FOR ATTACHMENTS

The manufacturer provides a wide range of attachments guaranteed and perfectly adapted to the vehicle.

Attachments include a vehicle-specific load chart.

For some specific applications, attachments not included in the optionals may need to be adapted. For more information, consult your authorized retailer.

Carefully follow the instructions in this manual for the use of the attachments.

## NOTICE

### Use of attachments not approved or without "CE" declaration of conformity

The manufacturer is not responsible for modifications or the use of non-approved attachments or those without a "CE" declaration of conformity.

Do not use attachments without type approval or without a "CE" declaration of conformity on Manitou vehicles.

The user must request the suitability for use check by an authorized MANITOU technician before commissioning, and include the documentation necessary for the use of the new attachment.

General advice regarding use of the attachment

## NOTICE

### Ability to use the vehicle

Manitou guarantees the suitability of the vehicle for the normal conditions of use specified in the manual, with static and dynamic test coefficients in accordance with EN 1459 and EN 1726-1.

The static test coefficient is 1.33 and the dynamic test coefficient is 1.1.

## ⚠ DANGER

### Operations within vehicle capabilities

Overturning of the structure and consequent damage to property and harm to people.

Do not carry out lifting operations of loads that exceed the capacities of the vehicle.

In no case should you try to lift loads heavier than those allowed on the load charts attached to the machine.

Carry only well-balanced loads.

## NOTICE

### Lift only loads without people

The attachments described in this manual are not suitable for lifting or moving people.

## NOTICE

### Improper attachment use

Malfunction and damage to property and harm to people  
Be careful when using and installing the attachment to  
avoid collisions with parts of the machine.

Use the attachment correctly and follow safety guidelines.  
Before using any attachment on the vehicle, check the  
compatibility and calibration of the attachment safety  
system.

### 3.4.2 COUPLING MANEUVER FOR ATTACHMENTS

#### Fitting attachment

- Make sure the attachment is in a position that makes it easy to hook the quick coupler. In case it is pointing in the wrong direction, take the necessary precautions to move it in extremely safe conditions.
- Check that the blocking pin is inserted into the holder on the chassis.
- Position the vehicle with the boom lowered, facing front and parallel to the attachment and tilt the quick coupler forward (1).
- Bring the quick coupler under the connecting pipe of the attachment, raise the boom slightly and tilt the coupler backwards to position the attachment (2).
- Take the attachment off the ground to facilitate blocking (3).

#### If the attachment is equipped with a hydraulic circuit

**!** *Carefully clean the quick couplings and protect unused orifices with the plugs provided for this purpose.*

- After locking the attachment (see [Manual Blocking](#) or [Hydraulic Blocking and Unlocking](#)), it is necessary to:
  - Switch off the heat engine and maintain electrical contact on the vehicle.
  - Relieve the pressure of the attachment's hydraulic circuit by pressing the optional control button on the joystick 4 or 5 times.
  - Connect the quick couplings, respecting the logic of the hydraulic movements of the attachment.

#### REFIT OF THE ATTACHMENT WITH MANUAL BLOCK

##### Manual blocking

Take the blocking pin (4) on the support and insert it into the hole in the quick coupling (4a) to block the attachment (3).

Do not forget to put in the split pin (5).



Figure 211: Refitting the attachment with manual block

##### Manual release

Proceed in the reverse order to that of [Manual Locking](#) and make sure you put the blocking pin back into the support on the chassis.

### Removal (and installation) of the attachment

Proceed in the reverse order to that of [Fitting the attachment](#) making sure to place it in a safe position on flat, compact ground. If the attachment has a hydraulic system, disconnect the quick couplings after decompressing the circuit.

### REFIT OF THE ATTACHMENT WITH HYDRAULIC BLOCK (optional)

#### Fitting attachment

- Make sure the attachment is in a position that makes it easy to hook the quick coupler. In case it is pointing in the wrong direction, take the necessary precautions to move it in extremely safe conditions.
- Check that the blocking pin is inserted into the holder on the chassis.
- Position the vehicle with the boom lowered, facing front and parallel to the attachment and tilt the quick coupler forward (1).
- Bring the quick coupler under the connecting pipe of the attachment, raise the boom slightly and tilt the coupler backwards to position the attachment (2).
- Take the attachment off the ground to facilitate blocking (3).
- Use the optional command to block the attachment.

#### Hydraulic blocking and unblocking

The blocking and unblocking of any attachment takes place by means of two pins which protrude from the holes of the quick coupling (4).

### Removal (and installation) of the attachment

Proceed in the reverse order to that of [Fitting the attachment](#) making sure to place it in a safe position on flat, compact ground. If the attachment has a hydraulic system, disconnect the quick couplings after decompressing the circuit.

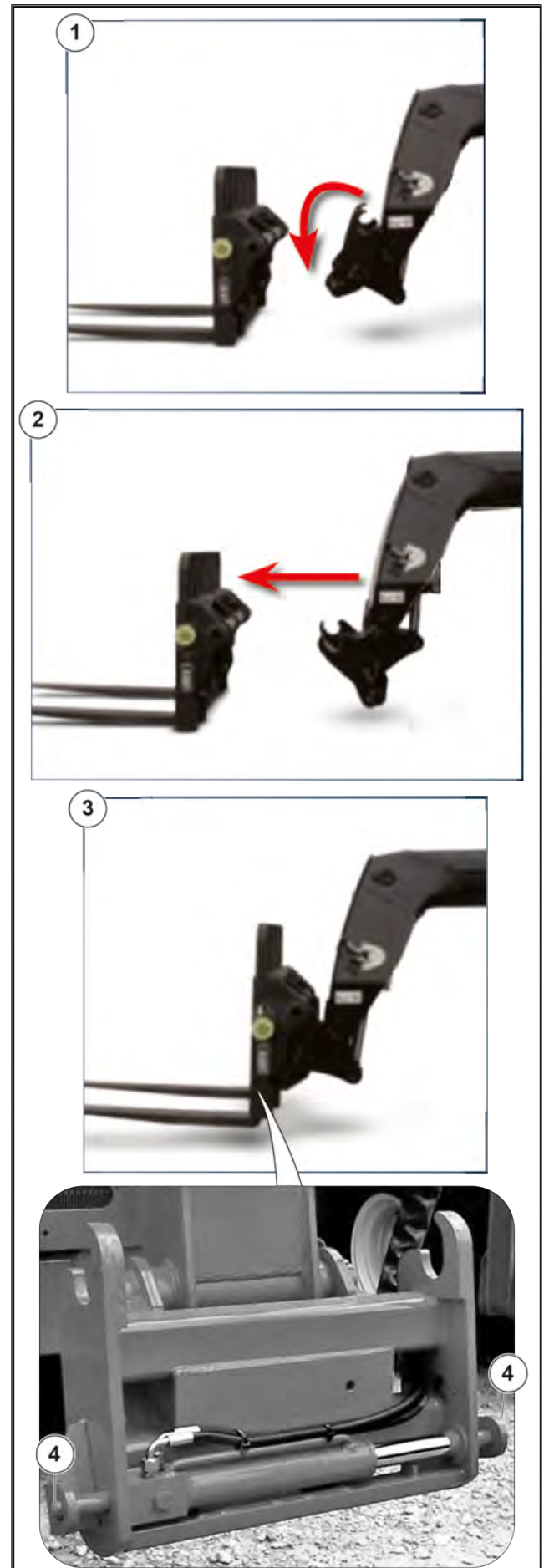


Figure 212: Refit of the attachment with hydraulic block (optional)

### 3.4.3 AUTOMATIC RECOGNITION OF THE "E-RECO" ATTACHMENT

The machine is equipped with an electronic recognition system that identifies the type of attachment installed at the time of coupling.

This system facilitates and speeds up attachment changing operations.

The system features two devices: one located on the telescopic boom and one on the attachment.

**Automatic mode:** after identification of the type of attachment and the operator's confirmation, the recognition system sets the machine to operate with the connected attachment.

**Manual mode:** the machine can operate with an attachment without an identification device and in this case it is the operator's responsibility to identify and confirm the type of attachment connected.



Figure 213: Selection and confirmation of attachment

#### Automatic mode

Straight after connecting an attachment, the recognition system:

- Identifies the type of attachment (1).

- Asks the Operator to confirm that the recognized attachment is the one actually connected to the machine.
- To confirm the type of attachment, press the knob selector (2).

#### Manual mode

Straight after connecting an attachment without the identification device, the recognition system:

- Does not recognize the connected attachment.
- The operator must select the type of attachment connected to the machine.

The operator must manually select the type of attachment installed, as follows:

- Press the key (3) to exit the "empty" mode (1) (no attachment connected).
- Turn the knob (2) to select the attachment that is connected.
- To confirm the type of attachment, press the knob selector (2).



*In "empty" mode the machine can move the boom but with maximum lifting capacity set at 1000 kg (2200 lb).*

### ⚠ WARNING

#### Risk of injury to people or damage to the vehicle

Not following recommendations could cause malfunctions of your vehicle and property damage and injuries to anyone close to the working area of the machine.

In both modes: it is the operator's responsibility to make sure that the attachment connected and shown on the display is the one identified by the recognition system or selected manually.



Figure 214: "E\_RECO" attachment recognition

### 3.4.4 MANUAL SELECTION OF ATTACHMENT HOOK

The recognition of the attachment hooked onto the telescopic boom occurs automatically via the "E-RECO" automatic recognition system.

If the attachment has the multiple choice of lifting hooks, the operator will have the chance to select the hook they intend to use.

**For example: the machine automatically recognizes the attachment and the operator will subsequently have to select the capacity of the hook using the manual selection procedure (for example: 13.5 T, 10 T or 7.5 T).**

### 3.4.5 FLOW LIMITER OF THE ATTACHMENT CIRCUIT

**▲ DANGER**

This option must be used only with an attachment requiring continuous hydraulic movement such as: sweeper, distribution bucket, mixer, sprayer, etc. Therefore it is strictly forbidden during handling and in all other cases (winch, boom, winch boom, hook, etc.).

#### Continuous hydraulic movement of the attachment

On the display, on the "DRIVE page", check that the oil flow percentage bar is on 0%.


Move the button (1) that controls the attachment backward and forward (according to the type of attachment), press the key (2) and release the button (1). The flashing light (1a) indicates its use.

On the display, at the bottom of the "DRIVE page", the bar that regulates the oil flow (3) is activated with the "+ / -" keys as needed, from 0% to 100%.

Stopping the continuous hydraulic movement of the attachment depends on:

- Adjusting the bar that adjusts the oil flow to 0%.
- Moving the button (1) that controls the attachment backward or forward.
- Press the key (2). The warning light (1a) is off.
- Or setting the potentiometer bar to 0%.
- Operator not seated.
- Exclusion of attachment movement control button (1) from key / navigator.
- Enabling and disabling control of 2nd hydraulic line on boom.
- Hydraulic block of the active attachment.
- Vehicle in alarm.

Before starting the vehicle check that the potentiometer bar is at 0%.

 If the operator moves away from the driver's cab, continuous hydraulic movement is automatically stopped and must be restarted.

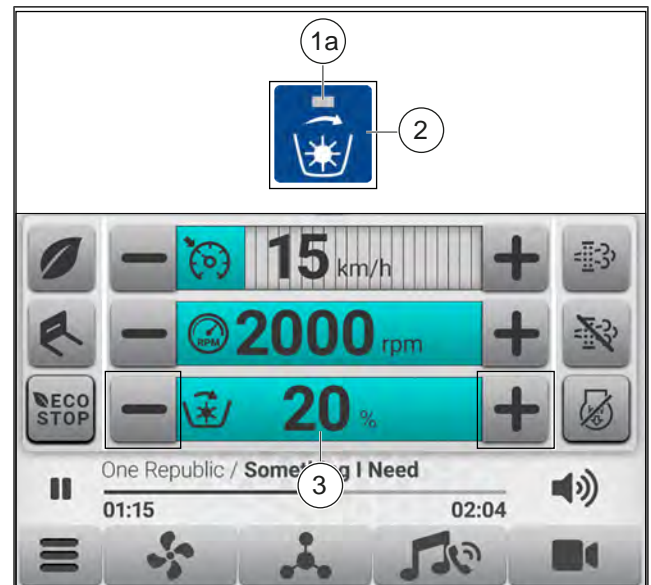


Figure 215: Continuous hydraulic movement of the attachment

## 3.5. DRIVING THE MACHINE

### 3.5.1 USING STEERING MODES

The vehicle is equipped with the following steering modes:

- Front wheel drive (driving on road) (1).

- Front and rear wheel drive in the same direction (lateral movement) (2).
- Opposite direction front and rear wheel drive (small turning radius) (3).
- Front wheel drive and rear wheel drive angle block (4).

⚠ When the steering mode is enabled, the warning light (5) is steady and the selected driving indicator is shown on the display.

⚠ Changing the steering mode is no longer possible when the speed exceeds 11 km/h (6.83 mph).



Figure 216: Steering mode

## CHANGING STEERING MODE

**⚠ DANGER**

Check the front and rear wheel alignment each time the telehandler is started.

The wheels must be aligned and the forklift truck must be in front-wheel driving mode during use on public roads.

### 3.5.2 USING THE SEMI-AUTOMATIC WHEEL ALIGNMENT

#### FRONT AND REAR WHEEL ALIGNMENT INDICATOR



Green indicator on: indicates the alignment of the front wheels with respect to the axis of the vehicle.

Yellow indicator on: indicates the alignment of the rear wheels with respect to the axis of the vehicle.

Front and rear wheel alignment procedure

1. Select the steering mode "opposite direction front and rear wheel drive (small turning radius)".
2. Turn the steering wheel so that the yellow rear wheels alignment light comes on.
3. Select the steering mode "Front-wheel drive (driving on road)".
4. Turn the steering wheel so that the green front wheels alignment light comes on.

1. Align the front and rear wheels.
2. Press the key (1, 2, 3, 4) to select the desired direction mode, the flashing warning light (5) confirms the request.



Figure 217: Steering mode

When the steering mode is enabled, the warning light (5) is steady and the selected driving indicator is shown on the display.

Once the front and rear wheels are aligned, one of the steering modes can be selected.

With use, the wheels may become uncoordinated, at least every 20 hours of operation the realignment of the wheels must be carried out.

### 3.5.3 USING THE PARKING BRAKE

The telehandler has the option of having automatic or manual application of the parking brake, which can be selected from keys in the cabin.

The parking brake acts on the front and rear axles.

- To activate the manual parking brake, press the key (1). A red warning light is lit on the display.
- To activate the automatic parking brake, press the button (2). A red warning light is lit on the display.

When the parking brake is applied, the brake lights come on for 2 minutes.

To release the parking brake, press key (1) or (2). The red light on the display will go out.

When starting the telehandler, the parking brake is engaged.

For the safety of the machine and the driver, the parking brake is applied automatically under certain conditions.

With the direction selector in the “neutral” position, the parking brake remains applied despite the pressure on the accelerator pedal.

With direction selected and by accelerating, the brake will be released and the vehicle will move.

The conditions for applying the safety brake are:

- The gearbox remains in the neutral position for several seconds.
- The traveling speed of the telehandler is less than 3.6 km / h (2.23 mph) or the machine has stopped.

The automatic emergency brake is disabled when the direction selector is enabled and the engine speed is increased by pressing the accelerator pedal.



Figure 218: Using the parking brake

### 3.5.4 USING THE GEAR SHIFT SELECTOR


The vehicle is equipped with a transmission with a two-speed manual gearbox:

- speed for work, slow gear
- speed for use on road, fast gear.



Press the button  in the cabin to switch from slow to fast gear. Each time the button is pressed



 changes the gear, and a LED lights up on the button.

The display shows the selected gear  or



Select the slow gear to move the vehicle at low speed.



The display shows the gear just selected

Select the fast gear to move the vehicle at maximum speed. The display shows the gear just selected




#### Procedure and conditions for changing gears:

- Stop the vehicle and keep the engine running

- Place the "F-N-R" direction selector on neutral
- release the accelerator pedal
- keep the service brake pedal pressed



- press the button  to change gear. The

display shows which gear is selected  or



- release the service brake pedal to move the vehicle in the desired direction.

### 3.5.5 DRIVING MODES

The telehandler equipped with electronically controlled transmission allows the operator to choose from three different driving modes:

1. Drive (for road use).
2. Handling (for work use).
3. Eco (to reduce consumption).

The operator selects the mode based on the driving feeling he wants to achieve with the telehandler and according to the different operating needs.

When the telehandler is switched on, the "Drive" mode is active by default.

#### 1. "Drive" mode:

It allows the operator a dynamic and rapid drive; it is ideal for all uses where speed is crucial. In fact, you have the maximum driving speed: - in low gear: 0 - 14 km / h (0 - 8.6 mph) - in high gear: 0 - 40 km / h (0 - 24.8 mph). Mode can be activated in low and high gear.

#### 2. "Handling" mode:

It allows the operator to have maximum progressivity and torque performance for all heavy handling and loading tasks.

When the operator makes the telehandler go forward or reverses it and moves the joysticks to control the hydraulic movements, the engine revolutions automatically increase up to maximum speed (if necessary), but the traveling speed does not change and always requires pedal action on the accelerator. While with the telehandler parked "on tires" or on "stabilizers" the operator can increase (+) or decrease (-) the engine revolutions (rpm) on the display (2A). The set value will be the minimum number of engine revolutions below which it is not possible to go. The number of engine revolutions will only increase during hydraulic movements.

The maximum traveling speed of the telehandler is limited:

- In low gear: 0 - 14 km / h (0 - 8.6 mph).
- In high gear: 0 - 25 km / h (0 - 15.5 mph).

Mode can be activated in low and high gear.

#### 3. ECO mode:

This feature adjusts the transmission to maintain the maximum traveling speed of the telehandler at a lower engine RPM, thus saving fuel.

- In low gear: 0 - 14 km / h (0 - 8.6 mph).
- In high gear: 0 - 40 km / h (0 - 24.8 mph).

When the speed is reached (with the accelerator pedal), if maintained for a short period of time, the ECO feature is activated.

Mode can be activated in low and high gear.



Figure 219: Driving modes

### 3.5.6 USING THE FORWARD / NEUTRAL / REVERSE DIRECTION SELECTOR (FNR)

To move the telehandler forward or to reverse, press the "FNR" selector located on the right joystick of the operator's seat.

FORWARD GEAR (F): push the selector (1) forward

REVERSE (R): push the selector (1) back.

- The rear video camera will be activated automatically and the pre-defined screen with video recording on the display in the cabin turn on.

IN NEUTRAL (N): to start the telehandler, the selector (1) must be in the neutral position (N). The selected direction is shown on the display on the "DRIVE" page.

Getting the telehandler to go in the opposite direction must be done at low speed and without accelerating.

**Getting the telehandler to go forward or to reverse**

To allow and enable movement of the machine, the operator must:

- Close the cabin door.
- Fasten the seat belt (in this condition it is possible to move even with the door open).
- Be seated in the driver's cab.
- Select low or high gear.
- Release the parking brake.
- Check that the machine is positioned on tires:
  - With front turret (no more than  $\pm 5^\circ$  of rotation).
  - With turret rotated over  $\pm 5^\circ$  and the telescopic boom raised to less than 3 m / 9.8 ft.  
An alarm sounds and control panel lights in the cabin turn on to warn you that the turret is not in the front position and the boom is too high.
- Check that the stabilizer booms are:
  - Lifted off the ground.
  - Completely closed.
  - Not fully closed (even just one boom open) with an alert for the operator.  
a warning that stabilizers are not closed sounds and lights up on the control panel in the cabin.  
It is possible to lower the stabilizers while the machine is in motion, but if even one stabilizer rests on the ground, the movement of the rotary telehandler is disabled.  
If the stabilizer booms are not fully closed, a warning that the stabilizer booms are not closed sounds and lights up on the control panel in the cabin.

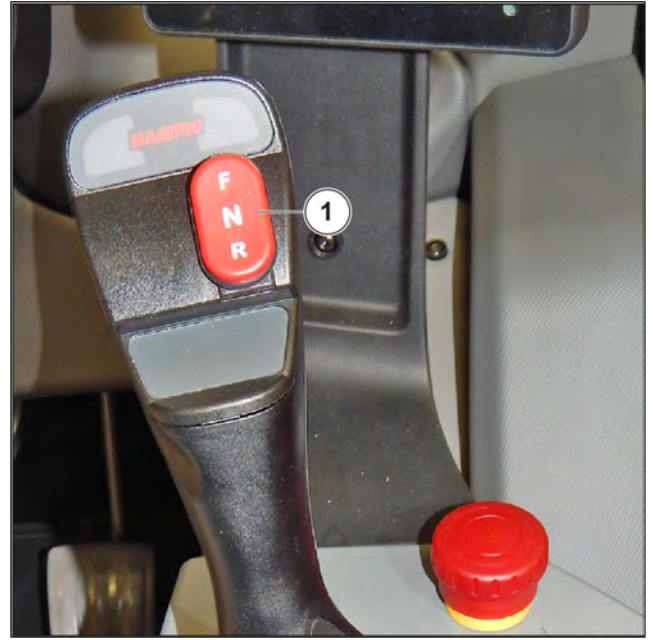


Figure 220: Using the FNR selector

### 3.5.7 TRAVEL SAFETY SYSTEM RESET BUTTON

The telehandler does not travel in some conditions:

- With forward or reverse selector engaged (F / R) and stabilizers resting on the ground (even just 1).
- With turret rotated more than  $\pm 5^\circ$  and the telescopic boom raised to a height of more than 3 m / 9.8 ft off the ground.
- With turret rotated more than  $\pm 5^\circ$  and the telescopic boom not fully retracted.

Only in exceptional cases and for safety reasons it is possible to move by pressing the travel safety system reset button (1).

- To allow the movement, the operator must briefly press the key (1), a LED (2) on key and a red icon on the display light up to indicate that the feature is enabled.
- To reset the travel safety system, press the button (1) again so that the LED (2) on the key and the icon on the display go out.

**⚠ DANGER**

**Risk of injury to the operator or damage to the telehandler**

In order not to compromise the stability of the telehandler, move slowly for short distances on flat and level ground.



Figure 221: Travel safety system reset button

## 3.6. STABILITY OF THE MACHINE

### 3.6.1 BLOCKING REAR AXLE SWING


The telehandler is equipped with an automatic rear axle swing block device, on wheels, to work with maximum safety and maintain optimal capacity.

Depending on the model of the telescopic handler, the operation of the rear axle is connected to the logic of the rear suspension rams or without suspensions, it is connected to two additional solenoid valves that manage the blocking / unblocking of the rear axle.

To activate the unblocking of the rear axle you must be in the following conditions:

- Turret rotated with an angle of no more than +/- 15°.
- Telescopic boom raised to no more than 55°.
- Red emergency mushroom button not pressed.

When the rear deck swing block feature is enabled, an

amber indicator  will light up in the upper display area.

### 3.6.2. USING THE STABILIZERS

#### 3.6.2.1 USE OF STABILIZERS

(depending on vehicle model)

The vehicle is equipped with 4 stabilizers with independent control, allowing a ground support base of the following size:

- 3.9 m (12.7 ft) length and 4.6 m (15ft) width (MRT 1645 – MRT 1845),
- 4.7 m (15.4 ft) length and 4.9 m (16 ft) width (MRT 2545 – MRT 2545),

thus ensuring the vehicle stability and safety at work.

**⚠ DANGER**

The vehicle is considered stabilized when the 4 stabilizing feet are resting on the ground and the 4 tires are completely lifted off the ground. In addition, for some models (MRT 2145 – MRT 2545) the vehicle is properly stabilized if the support foot is outside of the pivot range of the two booms.

**⚠ DANGER**

**⚠ DANGER**

To activate the flow diagram on stabilizers the vehicle must be resting on all 4 stabilizers.

**⚠ DANGER**

Before use, any deposits of mud, earth, debris or dirt must be removed from the stabilizers so as not to affect their operation.



Figure 222: Removing debris and dirt from the stabilizers.

**⚠ DANGER**

Before starting a work cycle with a stabilized vehicle, always check the condition of the ground, which must not be slippery, yielding or uneven. Check that there are no obstacles such as bumps, walls, etc. that would prevent the correct opening of the stabilizers or the (automatic) extension of the second stabilizer boom (MRT 2145 – MRT 2545).

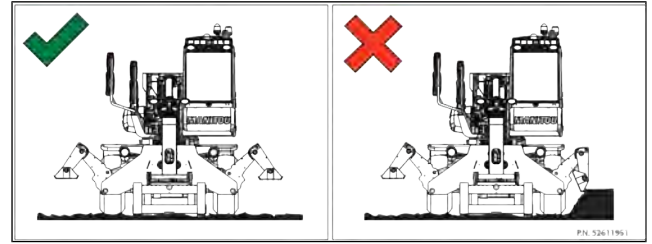


Figure 223: Check the condition of the ground and the absence of obstacles.



Figure 224: Check the correct opening or extension of the stabilizers.

**⚠ DANGER**

**Road traffic**

When driving on the road ensure that the 4 stabilizers are fully closed.



Figure 225: Road Traffic - Stabilizers completely closed (MRT 1645 - MRT 1845)



Figure 226: Road Traffic - Stabilizers completely closed (MRT 2145 - MRT 2545)

### 3.6.2.2 STABILIZER MOVEMENTS

- Manual stabilization.
- Automatic stabilization.
- Automatic de-stabilization.

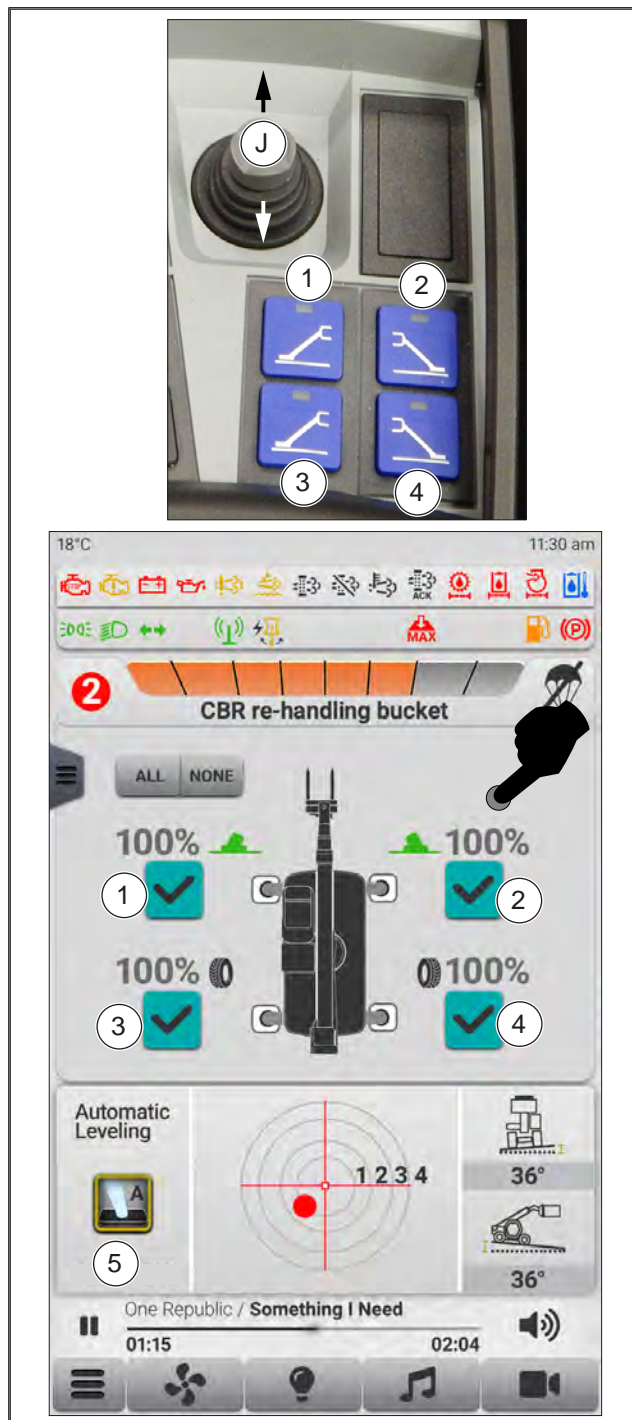


Figure 227: Stabilizer movements

### 3.6.2.3 MANUAL STABILIZATION PROCEDURE


Once the telescopic handler has been positioned in the work area and the stabilizers have been selected with the keys (1, 2, 3, 4) on the right armrest or by touch on the display on the "STABILITY" page, move the small joystick (J) that controls the lowering and the raising of the stabilizers. Next, stabilize or destabilize the telehandler according to the operation needed.

To stabilize the telehandler:

- Fully lower the 4 stabilizing feet so that they rest on the ground and stabilize the machine.

To destabilize the telehandler:

- Raise the stabilizing feet completely off the ground.

 *It is not possible to perform more than one movement at a time.*

To move the stabilizers, the operator must check that different conditions exist.

#### Conditions for stabilizer ascent block

- Telescopic boom completely closed.
- Telescopic boom raised to a height over 3m / 9.8ft.

### 3.6.2.4 STABILIZERS AUTOMATIC LEVELING PROCEDURE

The machine is equipped with a device for leveling the stabilizers, with respect to the ground in order to level the machine and then raise the boom to the maximum height in complete safety and stability.

#### Device operation

Before leveling the machine it is necessary to select the four stabilizers, keys (1, 2, 3, 4).

Select the "STABILITY" page on the display and at the bottom keep the button (5) pressed until the machine is leveled and stabilized.

On the display, check the machine level and stabilized indicators.

To enable automatic leveling of stabilizers, the operator must:

- Close the cabin door.
- Place the gear lever on neutral.
- Fully retract the telescopic boom.  
Check that you are positioned:
- With front turret (no more than +/- 5° of rotation) and telescopic boom tilt of less than 55°.
- With turret rotated (more than +/- 5° of rotation) and telescopic boom raised to a height of less than 3 m / 9.8 ft.

## 3.7. EMERGENCY PROCEDURES


### 3.7.1 EMERGENCY PROCEDURE

In case of emergency, if the safety system needs to be disabled, the operator must:

- Take the hammer (1) on the safety box (2).
- Break the protective glass (3) of the safety box (2).

- Take the key (4) and insert it in the key selector (5).
- Turn the key selector (5) to the " " position to disable the safety system.

Press and keep the key selector (5) turned (4) to " " position to proceed and continue to operate with the emergency maneuvers, making movements opposite to those that can generate instability and / or overload of the vehicle.

 *When the safety system is disabled, an acoustic alarm and a visible indicator (steady red light above the cabin) are automatically activated to warn the driver and any personnel outside the vehicle of a possible dangerous situation.*


 *Once the emergency procedure is completed, put the key (5) back inside the safety box (2) and replace the protective glass (3).*



Figure 228: Emergency procedure - Emergency keys safety box

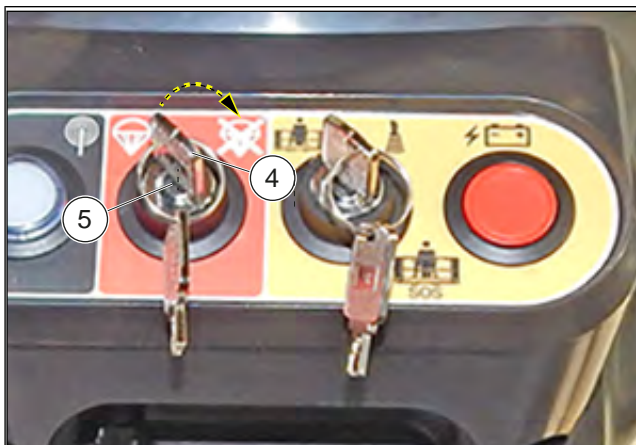


Figure 229: Emergency procedure - Selector to disconnect the safety system

### 3.7.2 EMERGENCY PROCEDURE FOR HIGH-VOLTAGE BATTERY FAULT

The vehicle is equipped with an emergency system that allows hydraulic movements of the machine (including stabilization) if the HV battery is discharged or malfunctioning.

The emergency systems turns the hydraulic pump on electrically using the 24V low voltage system.

**To activate the system:**



1. press the button
2. use the joystick to carry out hydraulic movements and/or the control buttons of the stabilizers.

## ⚠ DANGER

**Discharge the 12V batteries.**

Prolonged use of the emergency system causes the two 12V batteries to run down.

Complete the movements necessary for putting the load or the vehicle in safe conditions as quickly as possible.

## ⚠ DANGER

**The system does not power the traction motor and it is not possible move laterally.**

## 3.8. USE OF TOWING DEVICES

### 3.8.1 PIN AND TOWING HOOK

Located at the back of the vehicle, this device allows you to hook up a trailer.

For each vehicle, the capacity is limited by the total permitted working weight, the tractive force and the maximum lift capacity on the coupling point.



*To use a trailer, consult the regulations in force in your country (maximum travel speed, braking, maximum weight of the trailer, etc.). Check the condition of the trailer before using it (tire condition and pressure, electrical socket, hose).*

## ⚠ DANGER

**Risk of damage to the vehicle's steering and braking devices**


Using a trailer that is in poor condition could damage the steering and braking devices of the vehicle, and therefore compromise the safety of the machine.

Do not tow a trailer or attachment that is not in perfect working order.

## ⚠ DANGER

If the trailer coupling or uncoupling operations are carried out by someone else, that person must always be visible to the driver.

Before working on the trailer, wait for the vehicle to stop, the service brake to be applied and the combustion engine to be turned off.

 A rear view mirror allows for a more precise approach of the vehicle towards the trailer ring.

### 3.8.2 COUPLING FORK

#### Trailer coupling and uncoupling

- To hitch, move the telehandler as close as possible to the trailer ring.
- Apply the parking brake and switch off the heat engine.
- Remove the split pin 1, raise the tow pin 2, and position or remove the trailer ring.

**⚠ DANGER**

#### Risk of pinching or crushing

There is the risk of pinching or crushing during the maneuver.

Don't forget to put the split pin 1 back. When uncoupling, make sure the trailer is standing on its own.



Figure 230: Coupling fork

## 3.9. TRANSPORT OF THE MACHINE

### 3.9.1 TRANSPORTING THE TELESCOPIC HANDLER ON A TRAILER

Check that the safety recommendations relating to the transport platform have been followed before loading the telehandler, and verify that the driver of the means of transport is informed of the dimensional characteristics and weight of the telehandler

Before loading the telehandler, check on the display that the turret aligned and centered indicator is on.

Afterwards, it is necessary to block the rotation of the turret using the safety pin supplied with the telescopic handler.

**⚠ DANGER**

#### Risk of overturning

Make sure the platform is large enough and has the load capacity to transport the telehandler. Also check the allowed ground contact pressure for the platform with respect to the telehandler.

#### Blocking the rotation of the telehandler turret

1. Park the vehicle in a flat, unobstructed area.
2. Align and center the turret.
3. Stop the vehicle.
4. Unscrew the screw (2) that fixes the pin in its seat. Remove the pin and screw.

5.

**⚠ DANGER**

#### Risk of crushing

To position the safety pin, access the walkable surface above the vehicle's undercarriage via the right side ladder. During the safety pin positioning procedure, do not stand under the telescopic boom.

Insert the pin (1) in the seat on the turret (3) and slide it down as far as it will go.

6. Secure the pin with its fixing screw (2).



*After unloading the telehandler from the transport platform, extract the safety pin for blocking the turret rotation and put it back in its resting seat.*



Figure 231: Blocking turret rotation

### Load the telehandler

1. Block the wheels of the transport platform.

2. Fasten the loading ramps to the platform so that the smallest possible angle for lifting the telehandler is achieved.
3. Load the telehandler parallel to the platform.
4. Switch off the telehandler.

## ⚠ DANGER

### Danger of overturning

In case of loading of the telescopic handler on the transport platform by radio remote controlled driving, the operator must:

- maintain a safety distance of at least 3 m from the vehicle itself and which allows a good view of the loading operations, but which allows escape in the event of accidental overturning or rolling of the vehicle from the platform;
- make sure there is nobody in the loading area;
- make sure there is nobody in the cabin.

### Putting the telehandler in a harness

1. Secure wedges in front of and behind each tire.
2. Block the telehandler to the platform with sufficiently strong ropes or chains on the front and rear of the telehandler at the anchorage points (1).
3. Tighten the ropes or chains.

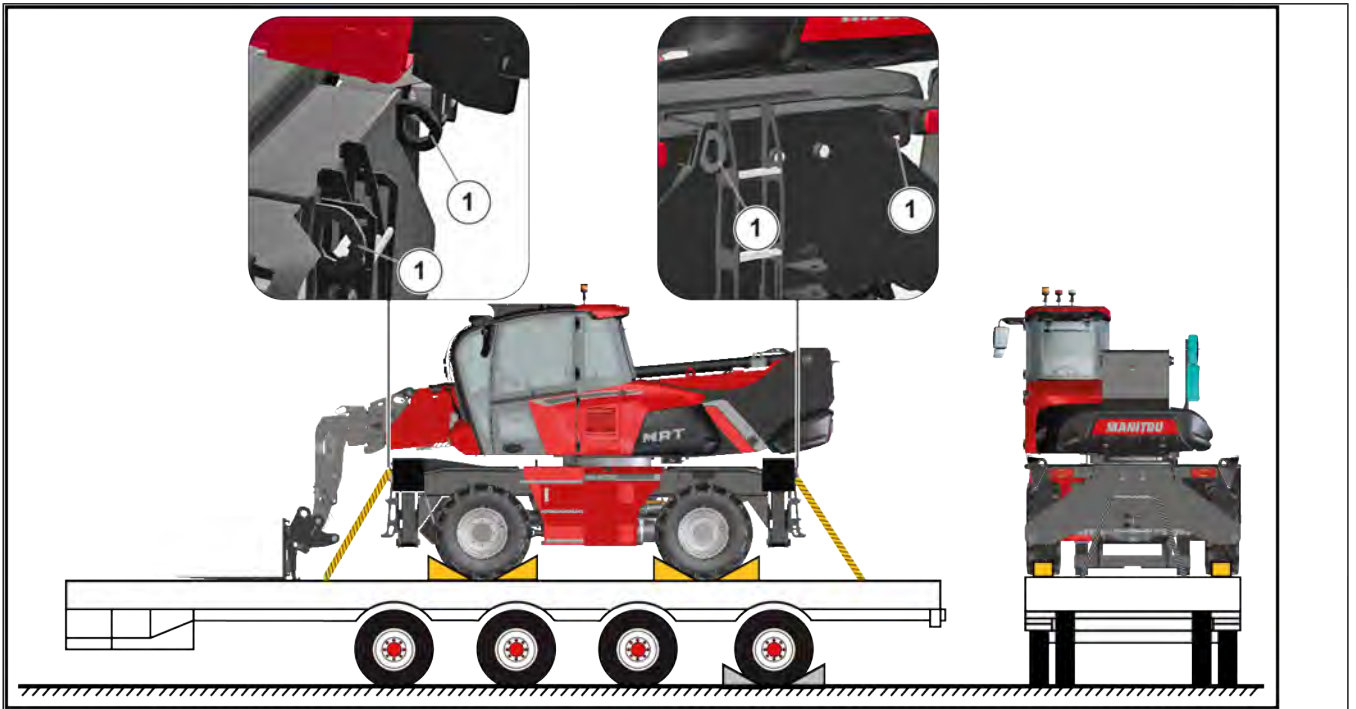


Figure 232: Putting the telehandler in a sling

### 3.9.2 PUTTING THE TELEHANDLER IN A SLING AND LIFTING IT

Take into account the position of the center of gravity of the telehandler for lifting.

Mod- el	A [mm]	A [in]	B [mm]	B [in]
1645	1369.3	54.77	1060.7	42.43
1845	1447.0	57.88	983.0	39.32

Mod- el	A [mm]	A [in]	B [mm]	B [in]
2145	1394.0	55.76	1336.0	53.44
2545	1460.0	58.4	1270.0	50.8



Figure 233: Center of gravity ratios

Lower the stabilizers of the rotating telehandler to the same height, measuring the extension of each rod of the "C" cylinders.

Follow the indication shown and presented below:

- **MRT 1645- 1845 C = 506.5 mm (19.94 in)**

- **MRT 2145 - 2545 C = 570 mm (22.44 in)**

Position the bands in the seats (2) provided for this purpose.

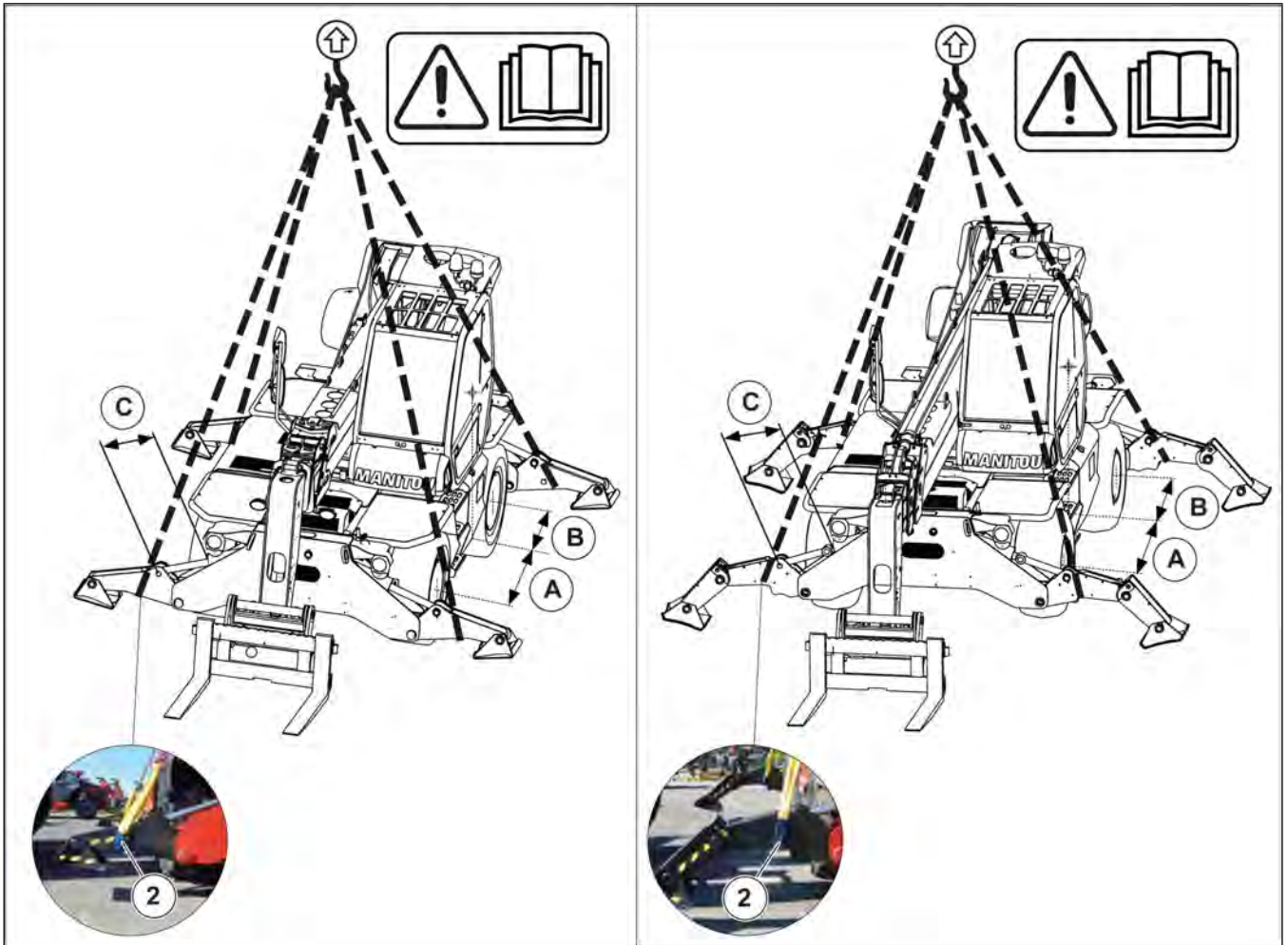



Figure 234: Putting the telehandler in a sling and lifting it (example)

### 3.9.3 TOWING OR HOOKING THE TELEHANDLER

 Towing can be done at very low speed and for short distances.

#### How to operate

Press the forward-reverse direction selector in neutral "N".

Release the parking brake.

Turn on the hazard lights.

Shift the gear into neutral on the gearbox:

1. Disconnect and plug the hydraulic hoses (3) from the jack of the low / high gearbox.

2. Leverage the stem (4) of the gearbox to make it come out and bring it to the neutral position (intermediate position between the two "next clicks").

3. Unlock the retaining assembly (1) with a mallet blow on the outer ring, - i

4. Insert pressure again and check that at the end of the piston stroke the retaining unit (1) engages on the rod (2).

In the absence of hydraulic steering and power brake assistance, act slowly and vigorously on these two controls.

Avoid sudden movements and jerks.

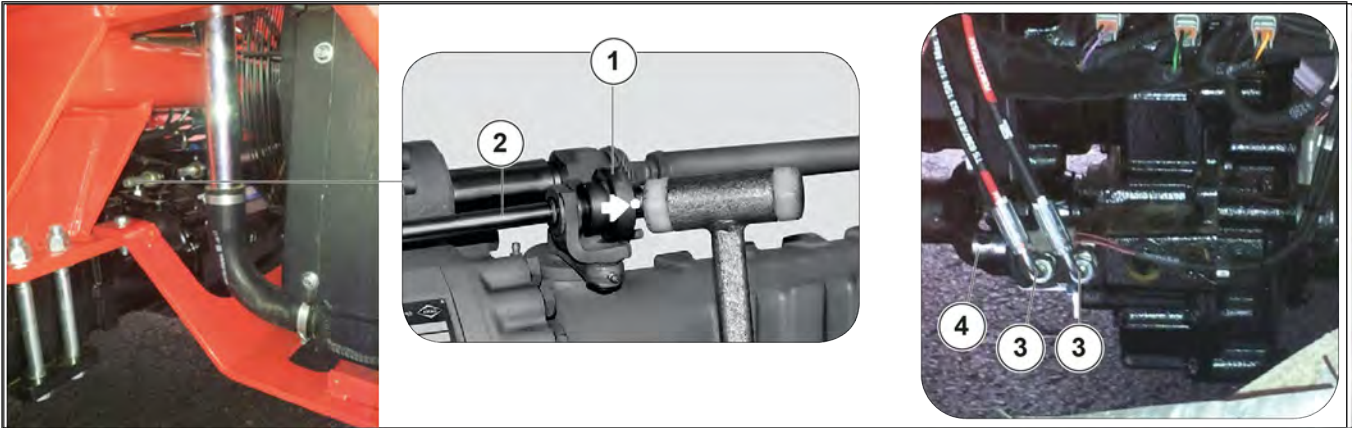



Figure 235: Towing or hooking the telehandler

## 4. MAINTENANCE


### 4.1. MAINTENANCE INTERVALS

#### 4.1.1 DAILY AND WEEKLY MAINTENANCE


 *The operator is authorized to perform this maintenance.*

These maintenance interventions allow the operator to keep the telehandler in a clean and safe condition.

#### 4.1.2 1ST MANDATORY SERVICE WITHIN THE FIRST 500 HOURS OR WITHIN 1 YEAR

 *This service must be carried out within the first 500 hours of operation or within 1 year from the commissioning of the vehicle (within the first deadline reached).*

#### 4.1.3 PERIODIC MAINTENANCE

 *Periodic maintenance should be performed by an authorized Manitou network professional.*

#### 4.1.4 MAINTENANCE AND OCCASIONAL OPERATIONS

The following work and operations must be carried out according to the safety and maintenance requirements of the telehandler.

### 4.2. SCHEDULED MAINTENANCE

#### 4.2.1 1ST MANDATORY SERVICE WITHIN THE FIRST 500 HOURS OR WITHIN 6 MONTHS

**First 500 hours before the initial 6 months.**

If the telehandler has reached 500 hours prior to 6 months of service, perform the 1st mandatory service and the 500-hour periodic maintenance.

**First 6 months before the initial 500 hours.**

If the telehandler has not reached 500 hours of operation within the first 6 months, perform the 1st mandatory service at the dealership.

#### 1st mandatory service

Table 191. 1st mandatory service

Operation	Description	Notes
Replace	Engine oil and filter	
Check	V-belt tension	
Check	Oil level in the gearbox	
Check	Tire pressure	
Check	Tightening the wheel nuts	
Check	Differential seal of the front axle	
Check	Differential seal of the rear axle	
Check	Seal of the front wheel reducers	
Check	Seal of the rear wheel reducers	
Check	Tightening the telescopic boom shoes	
Check	Hydraulic and transmission oil level	
Check	Windscreen washer fluid level	
Check	Cabin ventilation filters	
Clean	Radiator grille	

<b>Operation</b>	<b>Description</b>	<b>Notes</b>
Clean	Condenser grille (Air conditioning OPTION)	
Lubricate	General lubrication	
Check	Wear of the forks	
Check	Safety belt	
Check	Silent Block of the three-phase motor	
Check / Adjust	Suction system of the three-phase motor	
Check	Hoses and harness of the three-phase motor	
Check	Brake circuit pressure	
Check	Wear of the boom shoes	
Check	Condition of harnesses and cables	
Check	Lighting and signaling	
Check	Signalers	
Check	Condition of rear view mirrors	
Check	Cabin structure integrity	
Check	Chassis structure integrity	
Check	Quick coupling of attachments	
Check	Condition of attachments	

## 4.2.2 DAILY AND WEEKLY MAINTENANCE

### 10h - Daily maintenance or every 10 hours of operation

Table 192. 10h - Daily maintenance or every 10 hours of operation

<b>Operation</b>	<b>Description</b>	<b>Notes</b>
Check	Engine oil level	
Check	Coolant level	
Check	Telescopic boom sliding shoes	
Verify	"MSS" safety system	
Check	Fuel level	
Check	DEF liquid level	
Check	Fuel pre-filter	
Check	Cabin glass for damage	

### 50h - Weekly maintenance or every 50 hours of operation

Table 193. 50h - Weekly maintenance or every 50 hours of operation

<b>Operation</b>	<b>Description</b>	<b>Notes</b>
Check	Hydraulic oil level	
Check	Tire pressure and wheel nut tightening	
Clean	Water oil cooler grille of intercooler	
Lubricate	General lubrication	
Clean and lubricate	Telescopic boom wear shoes	
Clean and lubricate	Turret rotation ring	
Check	Windscreen washer fluid level	
Check and Clean	Condenser grille (Air Conditioning Optional)	

## 250h - Every 250 hours of operation

Table 194. 250h - Every 250 hours of operation

Operation	Description	Notes
Check	Front and rear axle differential oil level	
Check	Front and rear wheel reducers oil level	
Check	Gearbox oil level	
Check	Battery	
Check	Turret rotation reducer oil level	
Check, clean and lubricate	External boom chains	Just for: MRT 1845-2145-2545 and MRT-X 1845-2145-2545
Check	Rotation reducer fixing screws	
Check	Stabilizers descent and ascent system	Just for: MRT 2145-2545 e MRT-X 2145-2545

### 4.2.3 PERIODIC MAINTENANCE

## 500h - Periodic maintenance - every 500 hours of operation or 1 year

Table 195. 500h - Periodic maintenance - every 500 hours of operation or 1 year

Operation	Description	Notes
Check	Contamination of hydraulic oil	
Replace	Hydrostatic pump (transmission) oil filter	
Replace	Hydraulic oil filter cartridge (drain)	
Replace	Hydraulic oil breather	
Check	Fifth wheel and turret fixing bolts	
Check	Wear of the forks	Contact your dealer
Check	Cabin ventilation filters	
Check	V-belt tension	

## 1000h - Periodic maintenance - every 1000 hours of operation or 2 years


 Also carry out periodic maintenance of the 500 hours of operation.

Table 196. 1000h - Periodic maintenance - every 1000 hours of operation or 1 year

Operation	Description	Notes
Replace	Front and rear axle differential oil	
Replace	Front and rear wheel reducer oil	
Replace	Gearbox oil	
Replace	Dry air filter cartridge	
Clean	Fuel tank	
Replace	Fuel pre-filter	
Check / Clean	Fuel pump filter	
Replace	Fuel filter	
Replace	Engine oil and filter	Before changing the engine oil and filter, activate the forced regeneration. Refer to the "Occasional Maintenance" chapter for the forced regeneration activation procedure.*
Replace	Coolant	
Replace	Cabin ventilation filters	

<b>Operation</b>	<b>Description</b>	<b>Notes</b>
Check	Wear of the external chains of the telescopic boom	Just for: MRT 1845-2145-2545 and MRT-X 1845-2145-2545
Verify	Wear and increased clearance of the fifth wheel bearings	
Replace	"DEF" boost pump filter	
Replace	"DEF" tank breather	
Check	Safety belt	
Check	Silent Block of the three-phase motor	Contact your dealer
Check / Adjust	Three-phase motor air intake system	Contact your dealer
Check	Three-phase motor hoses and pipes	Contact your dealer
Check	Brake circuit pressure	Contact your dealer
Check	Wear of the telescopic boom shoes	Contact your dealer
Check	Condition of harnesses and cables	Contact your dealer
Check	Lighting and signaling	Contact your dealer
Check	Signalers	Contact your dealer
Check	Condition of rear view mirrors	Contact your dealer
Check	Cabin structure integrity	Contact your dealer
Check	Chassis structure integrity	Contact your dealer
Replace	Stabilizers internal components	Just for: MRT 2145, MRT 2545, MRT-X 2145, MRT-X 2545
Check	Quick coupling of attachments	Contact your dealer
Check	Condition of attachments	Contact your dealer
Check	Service and parking brake	Contact your dealer



\*Forced regeneration can be activated after about 400 h of engine life.

## 2000h - Periodic maintenance - every 2000 hours of operation or 4 years



Also carry out periodic maintenance of the 500 hours and 1000 hours of operation.

Table 197. 2000h - Periodic maintenance - every 2000 hours of operation or 2 years

<b>Operation</b>	<b>Description</b>	<b>Notes</b>
Check	Tire pressure and wheel nut tightening	
Replace	Hydraulic oil	
Clean	Hydraulics intake filter cartridges	
Check	Radiator	Contact your dealer
Check	Transmission pressures	Contact your dealer
Check	Steering	Contact your dealer
Check	Condition of the boom assembly	Contact your dealer
Check	Bearings and articulation rings	Contact your dealer
Check	Conditions of hoses and pipes	Contact your dealer
Check	Condition of jacks (leak, rods)	Contact your dealer
Check	Pressures of hydraulic circuits	Contact your dealer
Check	Bearings and articulation rings	Contact your dealer

Operation	Description	Notes
Clean / Check	Air conditioning (OPTIONAL)	Contact your dealer
Replace	Three-phase motor service belt	Contact your dealer

### 3000h - Periodic maintenance - every 3000 hours of operation or 6 years


 Also carry out periodic maintenance of the 500 hours and 1000 hours of operation.

Table 198. 3000h - Periodic maintenance - every 3000 hours of operation or 3 years

Operation	Description	Notes
Replace	Air filter safety cartridge	

## 4.2.4 OCCASIONAL MAINTENANCE

Table 199. Occasional maintenance

Operation	Description	Notes
Install	Telescopic boom safety wedge	
Replace	Wheel	
Regular	Headlights	
Replace	Fuses and relays	
Check / clean	Rotating electric collector transmitter rings (after 3 months of inactivity)	
Verify	Radio control	
Check / Clean	Fuel tank filler filter	
Check / Clean	DEF tank filler filter	
Clean	Stationary regeneration of DPF filter "Handler stopped"	

## 4.3. EVERY 10 HOURS OF OPERATION OR DAILY

- If necessary, remove the cap (2) on the cylinder head and add new oil through the filler port (3).

### 4.3.1 CHECKING THE OIL LEVEL IN THE ENGINE

**⚠ DANGER**

#### Risk of damage to the engine or exhaust after-treatment unit

Do not add too much oil. Adding too much oil can cause damage to the engine or the exhaust after-treatment unit. Drain or suck up excess oil.

Place the telehandler on a level surface with the heat engine off, and let the oil settle in the crankcase.

- Open the engine cover.
- Remove the dipstick (1).
- Clean the dipstick and check that the level is between the two marks.

5. By means of a visual check, make sure that there are no leaks or sweating.

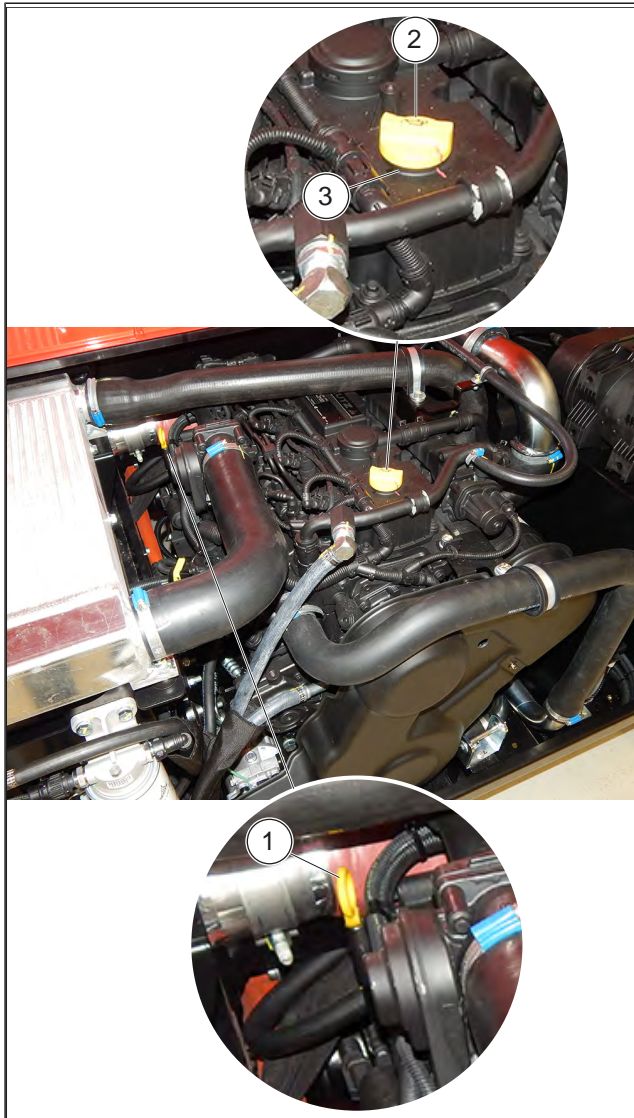


Figure 236: Engine oil level

### 4.3.2 CHECKING THE COOLANT LEVEL

#### ⚠ WARNING

##### Risk of getting a burn

Pressurized system: Hot coolant can cause severe burns. When opening the filler cap, stop the engine and wait for the cooling system components to cool. Loosen the pressure cap slowly to relieve pressure. Never add cold coolant when the engine is hot. In an emergency, it is possible to use water as a coolant, and then proceed, as quickly as possible, to change the fluid in the cooling circuit.

#### ⚠ DANGER

##### Risk of introducing an air lock into the cooling system

When performing any maintenance or repair of the engine cooling system, the procedure must be performed with the engine at ground level.

This allows you to accurately check the coolant level and avoid the risk of introducing an air lock into the cooling system.

1. Open the engine cover.
2. Check the correct level in relation to the center of the indicator (1).
3. If necessary, add coolant.
4. Slowly pull the radiator cap (2) up to the safety stop.
5. Let the pressure and steam escape.
6. Press the cap and remove it by turning.
7. Add coolant through the fill orifice (3) up to the center of the indicator (1).
8. Slightly lubricate the fill orifice to make it easier to replace and remove the radiator cap.

9. Look to make sure that there are no leaks on the radiator or pipes.

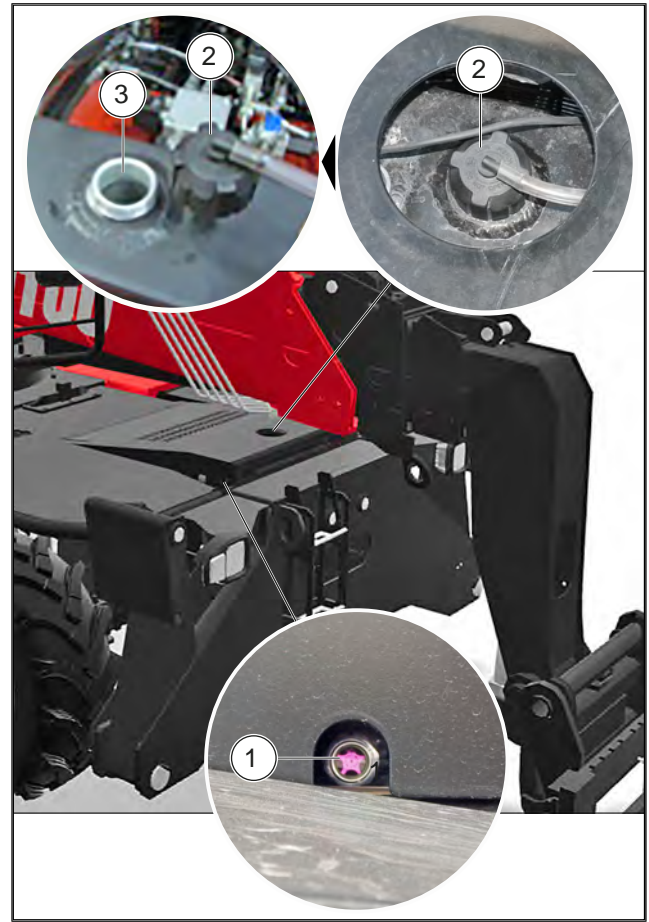


Figure 237: Coolant level

### 4.3.3 CHECKING THE TELESCOPIC BOOM SLIDING SHOES

To maintain optimum operation, keep the sliding shoes and telescopic boom extensions lubricated.

#### NOTICE

LUBRICATION OF THE TELESCOPIC BOOM REQUIRED AFTER:

Cleaning the boom, especially with high pressure lances.  
Long period of non-use of the telescopic handler.

1. Fully extend the telescopic boom extensions.
2. Check the condition of the surface of the telescopic extensions: the surface must be clean and without signs of corrosion.
3. Check the condition of the shoes and that they correctly guide the extension and retraction movement of each boom extension.
4. If necessary, lubricate the telescopic boom extensions with specific grease to maintain the correct sliding of the sliding shoes:
  - a. Extend and retract the boom several times to spread the grease evenly.

- Remove excess grease.

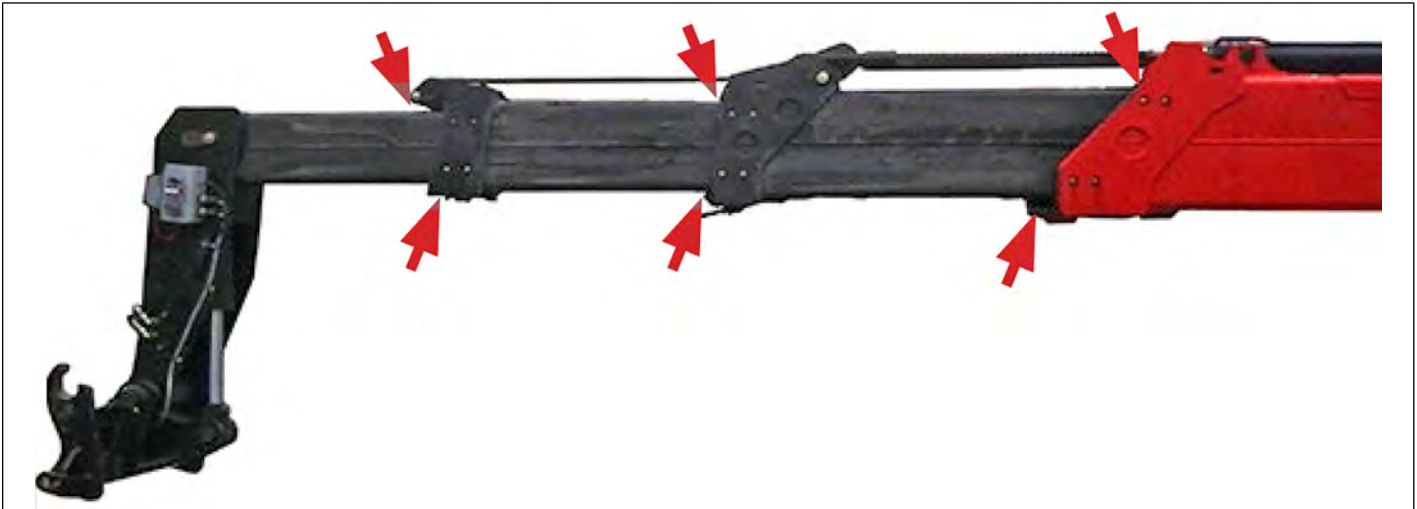


Figure 238: Telescopic boom sliding shoes

⚠ In case of use in an abrasive atmosphere (dust, sand, coal) use a sliding paint (reference MANITOU: 483536). Get advise from your dealer.

#### 4.3.4 CHECKING THE "MSS" SAFETY SYSTEM

- With the help of a metric cord and a spirit level check the indications of boom length (L) and angle (A).
- Then check the operation of the safety system by lifting a known weight, with forks, with the boom closed, and checking that the reading of the load on the display (1) is correct (WORKING page, "Geometrical" selection).
- Extend the load (keeping it about 0.5 m / 1.6 ft from the ground) and check that it reaches the limit set by the load chart and that the telescopic

handler blocks aggravating movements when the "MSS" safety system is activated



Figure 239: "MSS" safety system

#### 4.3.5 CHECKING THE FUEL LEVEL

Keep the fuel tank as full as possible to minimize condensation due to atmospheric conditions.

**⚠ DANGER**

**Risk of fire and explosion**

Do not smoke or approach with an open flame during filling operations or when the tank is open. Never fill up while the engine is running.

1. Check the indicator on the display (DRIVE page).  
If necessary, add diesel fuel.
2. Remove the cap (1).
3. Fill the tank with clean and filtered diesel fuel through the filler neck (2).
4. Put the cap (1) back on.
5. Look to make sure that there are no leaks on the tank or pipes.

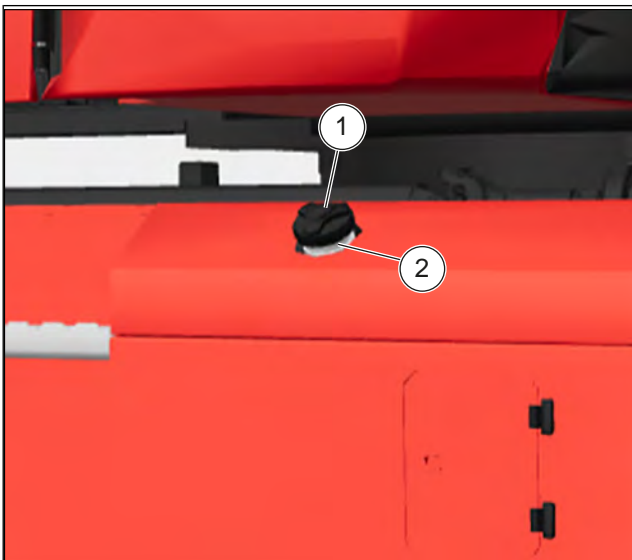


Figure 240: Fuel level

**4.3.6 CHECKING DEF LIQUID LEVEL**

**⚠ WARNING**

**Risk of contact with irritants**

If the “DEF” tank cap is opened in high temperatures, ammonia vapors may escape. Ammonia vapors have a pungent odor and are particularly irritating to the skin, mucous membranes and eyes. The presence of the vapors can cause a burning sensation in the eyes, nose and oral cavities as well as coughing and watery eyes. Do not inhale ammonia vapors.

**⚠ WARNING**

**Risk of contact with irritants**

If “DEF” comes into contact with eyes or skin, rinse immediately and thoroughly with clean water. If “DEF” is swallowed, rinse your mouth immediately with plenty of clean water and drink plenty of water. Change clothing soiled with “DEF” immediately. In case of allergic reactions, go to a doctor immediately for advice. Keep “DEF” out of the reach of children. “DEF” must not come into contact with the skin, eyes or clothing.

**⚠ WARNING**

**Risk of getting a burn**

During operation and after the engine has stopped, “DEF” pipes and all connected components remain under pressure and can be very hot. When opening the system, there is the risk of being burnt by high temperature “DEF” sprays. Start work on the exhaust gas after treatment system no sooner than at least 5 minutes after the engine has been stopped. Slowly open the piping connections and blocking elements of the system components. When opening, cover the sectioning point with a piece of cloth. Wear protective gloves, clothing and goggles.

**⚠ DANGER**

**Risk of damage to thermostats and temperature sensors**

The penetration of “DEF” into the coolant circuit (even a tiny amount) damages the thermostats and temperature sensors. It is highly recommended to keep “DEF” separated from other consumables. Do not use the same containers and collection trays for “DEF” and other consumables. Do not use consumables containing traces of “DEF”.

**⚠ DANGER**

**Risk of damage to components**

The individual components of the DEF system react greatly even in the presence of the slightest trace of impurities in “DEF”. Use only clean containers and collection trays, suitable for containing “DEF”. Do not use “DEF” containing traces of impurities.

## ⚠ WARNING

### Risk of poisoning

Fire-fighting measures: "DEF" is not flammable. In case of fire, NH<sub>3</sub> (ammonia) can be released. In this case there is the danger of poisoning. Fire-fighting measures must be suitable for the environmental conditions.

## ⚠ DANGER

### Environmental protection warning Disposal of "DEF":

A small amount of "DEF" accidentally spilled is not a problem. The product is easily biodegradable and can be dispersed without problems in the sewer system using a lot of water. For the disposal of larger quantities of "DEF", always comply with the requirements of the law on environmental protection and recycling / disposal of waste. Packages containing residues of "DEF" must be treated the same way as "DEF". Completely empty the contents of the packages; this way after cleaning the packages can be reused.

1. Check the indicator on the display (DRIVE page).

If necessary, add "DEF" fluid.

2. Remove the cap (1).
3. Fill the tank with fresh, uncontaminated "DEF" fluid, through the filler neck (2).
4. Refit the cap (1).

5. Look to make sure that there are no leaks on the tank or pipes.

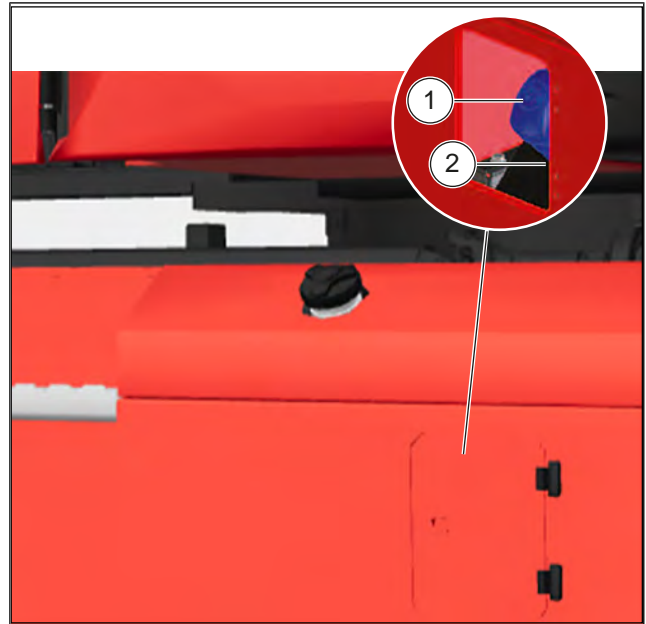


Figure 241: Checking DEF liquid level

### 4.3.7 FUEL PRE-FILTER CHECK

## ⚠ DANGER

### Fire risk

Fuel spilled on hot surfaces or electrical components can cause fires.

Turn off the start switch when changing filters or water separator element. Remove spilled fuel immediately. Make sure the engine has stopped before carrying out any maintenance or repairs. Thoroughly clean the outside of the prefilter and its holder to prevent dust from entering the system.

1. Open the engine cover and locate the fuel pre-filter (1).
2. Turn off the engine.
3. Place suitable collection containers under the engine.
4. Disconnect the electrical cable connections (2).
5. Loosen the bleeder cap (3).
6. Drain the liquid until only fuel comes out.
7. Replace the bleeder cap (3).



Tighten the cap with tightening torque:  
1,6 ± 0,3 Nm.

8. Connect the electrical cable connections (2).



Figure 242: Fuel pre-filter check

### 4.3.8 CABIN GLASS INTEGRITY CHECK

**⚠ DANGER**

#### Structural and/or superficial damage risk

The use of cleaning materials incompatible with the cabin windows can cause structural and/or surface damage. Do not use abrasive or highly alkaline cleaners on the cabin windows. Do not use aromatic or halogenated solvents such as toluene, benzene, gasoline, acetone or carbon tetrachloride on the cabin windows. If in doubt about the cleaning material, contact your agent or dealer.

**⚠ DANGER**

#### Risk of surface degradation and cracking

Contact with aggressive solvents such as methyl ethyl ketone (MEK) or hydrochloric acid can cause surface degradation and possible cracking of the cabin windows. Do not scrub with brushes, steel wool or other abrasive materials. Do not use spatulas, razor blades or other sharp tools to remove deposits or stains. Do not clean the cabin windows in direct sunlight or high temperatures as this may cause stains.

Cleaning and periodic inspection of the cabin windows, using correct procedures, is recommended for the safety of the operator and to prolong their service life.

- Thoroughly clean all windows in the cabin (windshield, rear window, upper window, side windows).

- Check the integrity of the windows on each side of the cabin.
- Check that there are no scratches, abrasions, cracks etc. In this case it is necessary to replace the glass.

**Contact your agent or dealer immediately.**

Here is how to clean the cabin windows in the best way and to keep them in good condition.

#### CLEANING PROCEDURE WITH CLEANING EQUIPMENT

- Clean the surface using a high pressure cleaner (max. 100 bar or 1,450 psi) and/or a steam cleaner. We suggest testing a small area before cleaning the entire glass.
- Avoid the use of water and/or steam additives.

#### MANUAL CLEANING PROCEDURE

- Gently wash the cloth with a mild soap and warm water solution, using a soft, non-abrasive cloth or sponge to remove dirt or grime.
  - Splashes of grease and soiled glass compounds can be removed easily before drying by wiping lightly with a soft cloth using petroleum ether (BP65), hexane or heptane.
  - Minor scratches and abrasions can be minimized by using a mild car polish cleaner. We suggest testing a small area of the glass with the selected cleaner (follow the instructions provided by the cleaner manufacturer).
- Contact your agent or dealer immediately.**
- Finally, rinse thoroughly with clean water to remove any detergent residue and dry the surface with a soft cloth to avoid water stains.

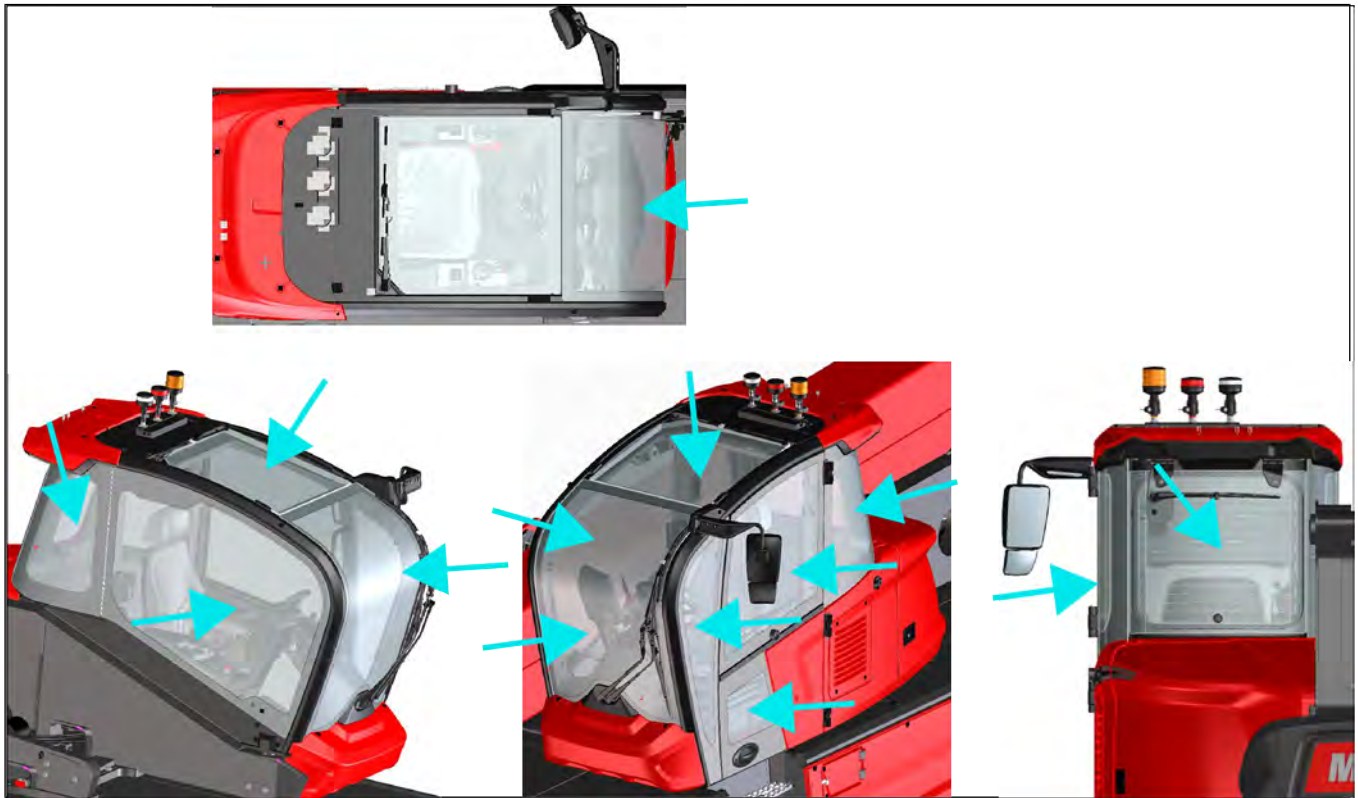


Figure 243: Cabin glass integrity check

#### 4.3.9 CABIN UPPER ANTI-BREAKAGE GLASS INTEGRITY CHECK (OPTIONAL)

### ⚠ DANGER

If the cabin is equipped with the "upper anti-breakage glass (optional) (1)", periodic maintenance is essential to keep the glass anti-breakage qualities and high impact resistance performance effective, thus providing the operator with greater safety and protection against any intrusion.

**⚠ DANGER****Structural and/or superficial damage risk**

The use of cleaning materials incompatible with the cabin windows can cause structural and/or surface damage.

Do not use abrasive or highly alkaline cleaners on the cabin windows. Do not use aromatic or halogenated solvents such as toluene, benzene, gasoline, acetone or carbon tetrachloride on the cabin windows. If in doubt about the cleaning material, contact your agent or dealer.

**⚠ DANGER****Surface degradation and glass cracking risk**

Contact with aggressive solvents such as methyl ethyl ketone (MEK) or hydrochloric acid can cause surface degradation and possible cracking of the cabin windows.

Do not scrub with brushes, steel wool or other abrasive materials. Do not use spatulas, razor blades or other sharp tools to remove deposits or stains. Do not clean the cabin windows in direct sunlight or high temperatures as this may cause stains.

**⚠ DANGER**

Replace the glass (1) every 10 years.

Cleaning and periodic inspection of the cabin windows, using correct procedures, is recommended for the safety of the operator and to prolong their service life.

- Thoroughly clean all windows in the cabin (windshield, rear window, upper window, side windows).
- Check the integrity of the windows on each side of the cabin.
- Check that there are no scratches, abrasions, cracks etc. In this case it is necessary to replace the glass. **Contact your agent or dealer immediately.**

Here is how to clean the cabin windows in the best way and to keep them in good condition.

**CLEANING PROCEDURE WITH CLEANING EQUIPMENT**

- Clean the surface using a high pressure cleaner (max. 100 bar or 1,450 psi) and/or a steam cleaner. We suggest testing a small area before cleaning the entire glass.
- Avoid the use of water and/or steam additives.

**MANUAL CLEANING PROCEDURE**

- Gently wash the cloth with a mild soap and warm water solution, using a soft, non-abrasive cloth or sponge to remove dirt or grime.
- Splashes of grease and soiled glass compounds can be removed easily before drying by wiping lightly with a soft cloth using petroleum ether (BP65), hexane or heptane.
- Minor scratches and abrasions can be minimized by using a mild car polish cleaner. We suggest testing a small area of the glass with the selected cleaner (follow the instructions provided by the cleaner manufacturer). **Contact your agent or dealer immediately.**
- Finally, rinse thoroughly with clean water to remove any detergent residue and dry the surface with a soft cloth to avoid water stains.

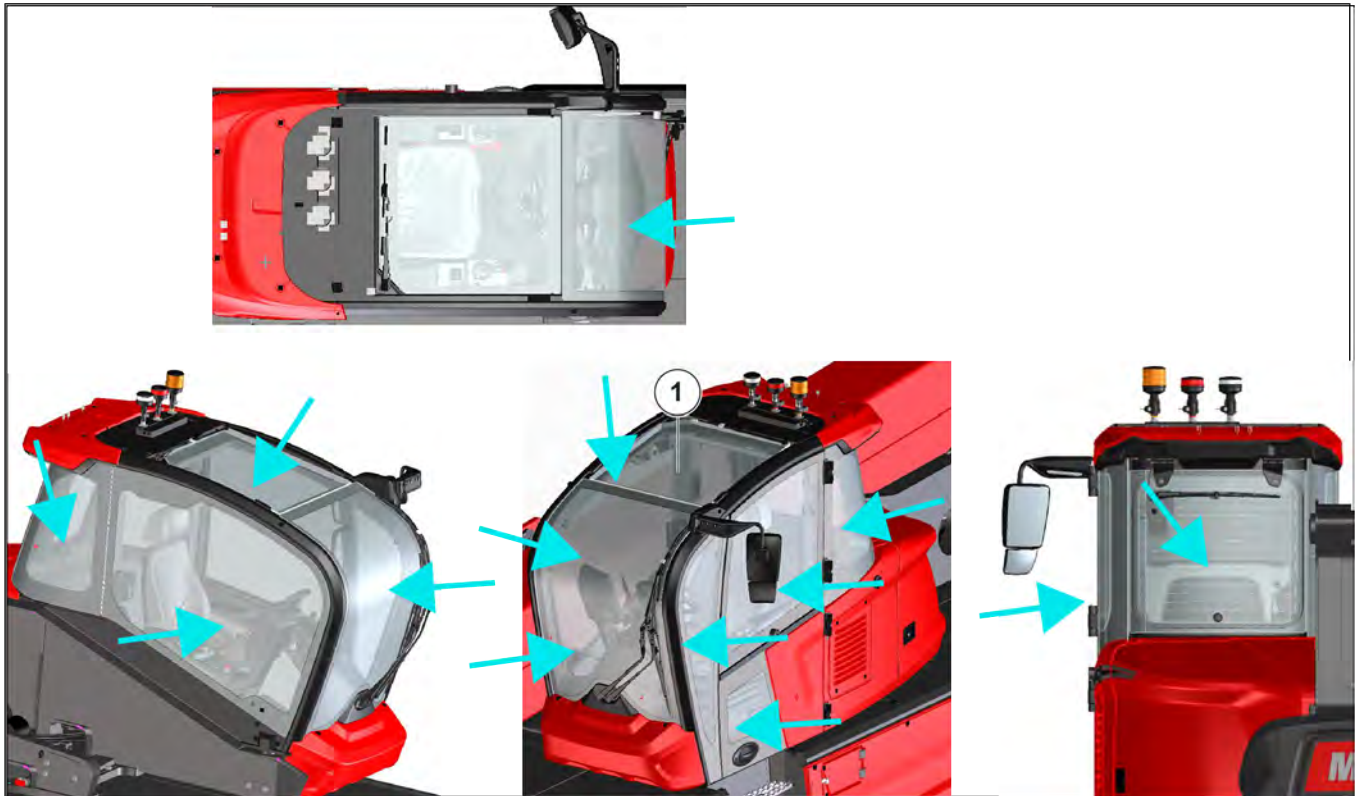


Figure 244: Cabin upper anti-breakage glass integrity check (optional)

## 4.4. EVERY 50 HOURS OF OPERATION OR WEEKLY

### 4.4.1 HYDRAULIC OIL LEVEL CHECK

Place the telehandler on a level surface with the engine off and the telescopic boom retracted and lowered as far as possible.

#### **⚠ DANGER**

Use a very clean funnel and clean the top of the oil can before filling.

1. Remove the tank protection panel (1).
2. Look to make sure that there are no leaks or sweating.
3. Check the oil level using the optical indicator (2) on the tank.

The oil level is correct when it is between the top and bottom marks.

If necessary, add new oil from the filler neck (4).

4. Remove the cap (3) from the filler neck (4) and top up with oil.

You must always keep the oil level at maximum.

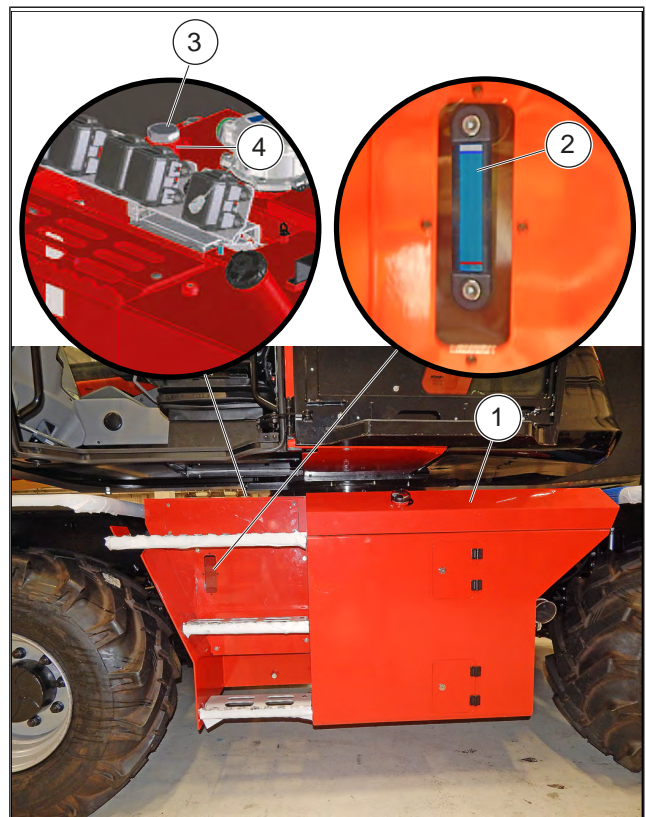


Figure 245: Hydraulic oil level check

### 4.4.2 TIRE PRESSURE AND WHEEL NUT TIGHTENING CHECK

**⚠ DANGER**

Check that the air tube is properly connected to the tire valve before starting the inflation and keep anyone away during the operations. Follow the recommended inflation pressures.

- Check the condition of the tires for cuts, bumps, wear, etc.
- Check the tightness of the wheel bolts. Failure to observe this warning could cause deterioration and breakage of the wheel pins, as well as deformation of the wheels themselves.
  - Front wheels: 680 Nm ± 15%.
  - Rear wheels: 680 Nm ± 15%
- Check and, if necessary, adjust the tire pressure (depending on the tire model equipped).

### 4.4.3 CLEANING THE RADIATOR GRILLE, HYDRAULIC OIL, INTERCOOLER AND COOLANT

**⚠ DANGER**

Adjust the frequency of cleaning according to the operating environment.

To access the hydraulic oil coolant radiator and air intercooler (1), open the engine cover (1a).

To access the coolant radiator (2), remove the panel on the front undercarriage (2a).

Inspect these radiator elements: damaged fins, corrosion, dirt, grease, insects, leaves, oil and other debris.

Clean the radiator if necessary.

Compressed air is the best method for removing debris.

Direct the air jet in the direction opposite the fan air flow (3). Hold the nozzle approximately 6 mm (0.25 in) from the radiator fins.

Slowly move the air nozzle parallel to the radiator pipes. Pressurized air removes debris from between the pipes.

**⚠ WARNING**

**Risk of injury**

Air pressure can cause personal injury. Failure to comply with safety measures can cause personal injury. When using compressed air, wear a face shield and

protective clothing. The maximum pressure at the compressed air nozzle for cleaning must be less than 21 bar (30psi).

Pressurized water can also be used for cleaning. The maximum water pressure for cleaning must be less than 2.8 bar (40 psi). Use pressurized water to soften the mud. Clean the core on both sides.

To remove oil and grease, use a degreaser and steam. Clean both sides of the core. Wash the core with detergent and boiling water. Rinse thoroughly with clean water.

Once the radiator is cleaned, start the engine. Warm up the engine at idle speed with no load for 3-5 minutes. Bring the engine to maximum speed. Running at full throttle helps remove debris and dry the core. Reduce the engine speed to idle and then stop the engine. Use a lamp behind the core to see if it is clean. Repeat cleaning if necessary.

Check if the fins are damaged. The folded fins can be opened with a “comb”. Inspect these items to verify they are in good condition: welds, mounting brackets, air lines, connections, clamps and seals. Make repairs if necessary.

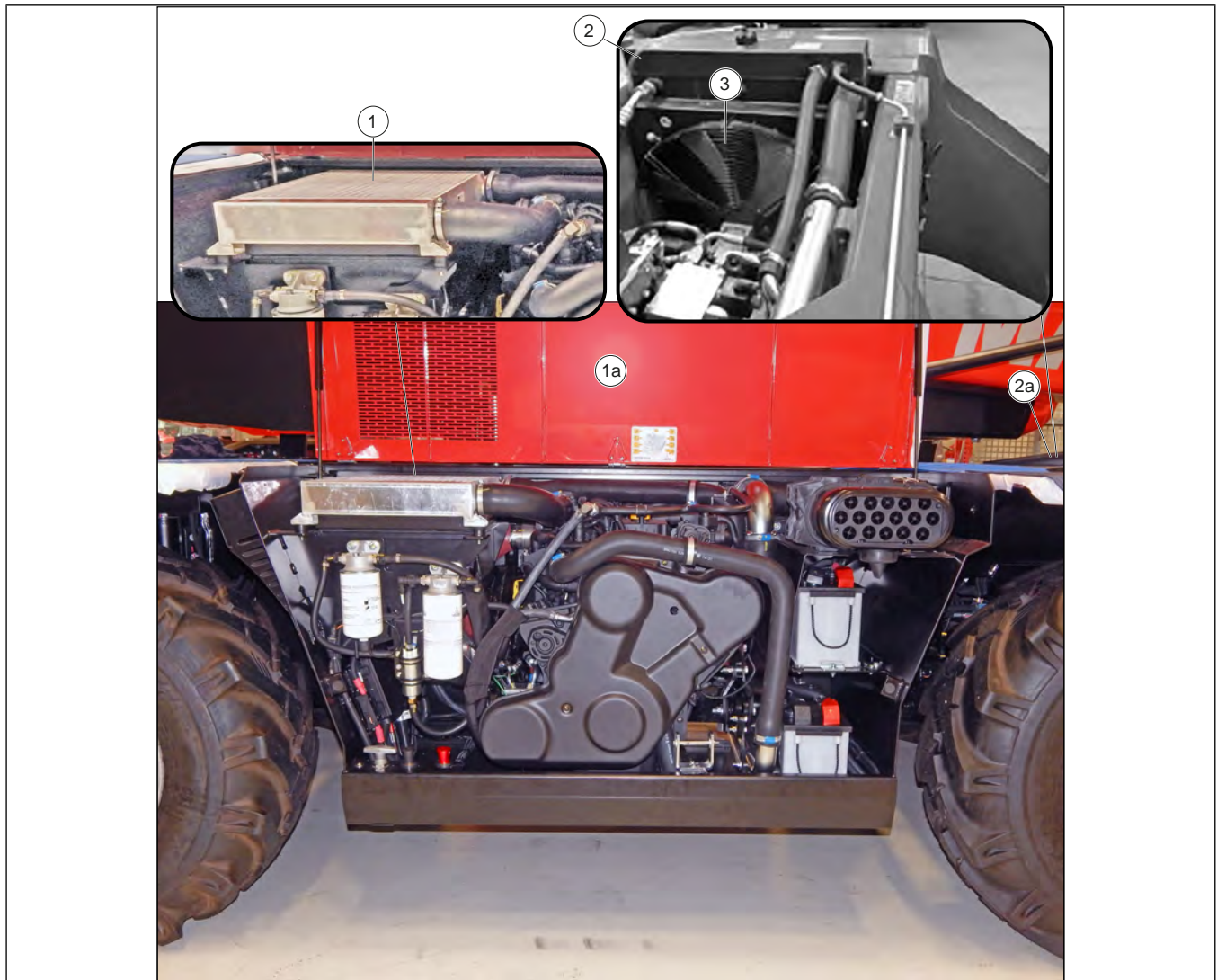


Figure 246: Cleaning the radiator grille, hydraulic oil, coolant and intercooler

#### 4.4.4 WINDSCREEN WASHER FLUID LEVEL CHECK

1. Open the grille (1) to access the windscreen washer fluid tank (2)
2. Visually check the tank level.
3. If necessary, add washer fluid from the filler neck (3).
4. Remove the filler cap (4).
5. Add windscreen washer fluid through the filler neck (3).
6. Replace the filler cap (4).
7. Replace the grille (1).



1. Visually check whether the condenser (1) is clean.  
Clean if necessary.
2. Clean the condenser with a jet of compressed air, directing it in the same direction as the air flow.

To optimize cleaning, carry out this operation with the fans on.

Figure 247: Checking and cleaning the condenser grille



Figure 1: Checking and cleaning the condenser grille



#### 4.4.5 CHECKING AND CLEANING THE CONDENSER GRILLE (OPTIONAL AIR CONDITIONER)

**⚠ DANGER**

##### Risk of damage to the condenser fins

Do not use a jet of water or high pressure steam, this could damage the condenser fins.

In a polluting atmosphere, clean the radiator grille daily.

#### 4.4.6 GENERAL LUBRICATION

To be carried out every week if the telehandler has not reached 50 hours of weekly running.

### **⚠ DANGER**

Raise the boom and place the safety wedge on the rod of the lifting cylinder.

In case of intense use in a very dusty or oxidizing atmosphere, reduce this frequency to 10 hours of operation or every day.

Clean, then lubricate the following points with grease and wipe off the excess.

#### **BOOM**

1. Boom axle lubricators (2 lubricators).
2. TS axle lubricators (2 lubricators)
3. Tilting cylinder foot axle lubricator (1 lubricator).
4. Tilting cylinder head axle lubricator (1 lubricator).
5. Lifting cylinder foot axle lubricator (1 lubricator).
6. Lifting cylinder head axle lubricator (1 lubricator).
7. Compensating cylinder foot axle lubricator (1 lubricator).
8. Compensating cylinder head axle lubricator (1 lubricator).
9. Telescopic boom chain roller axle lubricator 2 at the head of the boom (1 lubricator).
10. Telescopic boom chain roller axle lubricator 1 at the head of the boom (1 lubricator).
11. Telescopic boom chain roller axle lubricator 1 at the foot of the boom (1 lubricator).
12. Hose pulley axle lubricator on boom foot (1 lubricator).

#### **PINS OF FRONT AND REAR WHEEL REDUCERS**

13. Wheel reducer pin lubricators (8 lubricators).

#### **AXLE SWING**

14. Front axle swing lubricators (2 lubricators).

15. Rear axle swing lubricators (2 lubricators).

#### **CARDAN JOINT**

16. Apply grease to front and rear transmission shaft crosses and cardan.

#### **STABILIZERS**

17. Stabilizer cylinder foot axle lubricators (2 lubricators).
18. Stabilizer cylinder head axle lubricators (2 lubricators).
19. Stabilizer shaft lubricators (2 lubricators).
20. Cleaning of proximity sensors and microswitches.

#### **Overview of greasing points (example):**

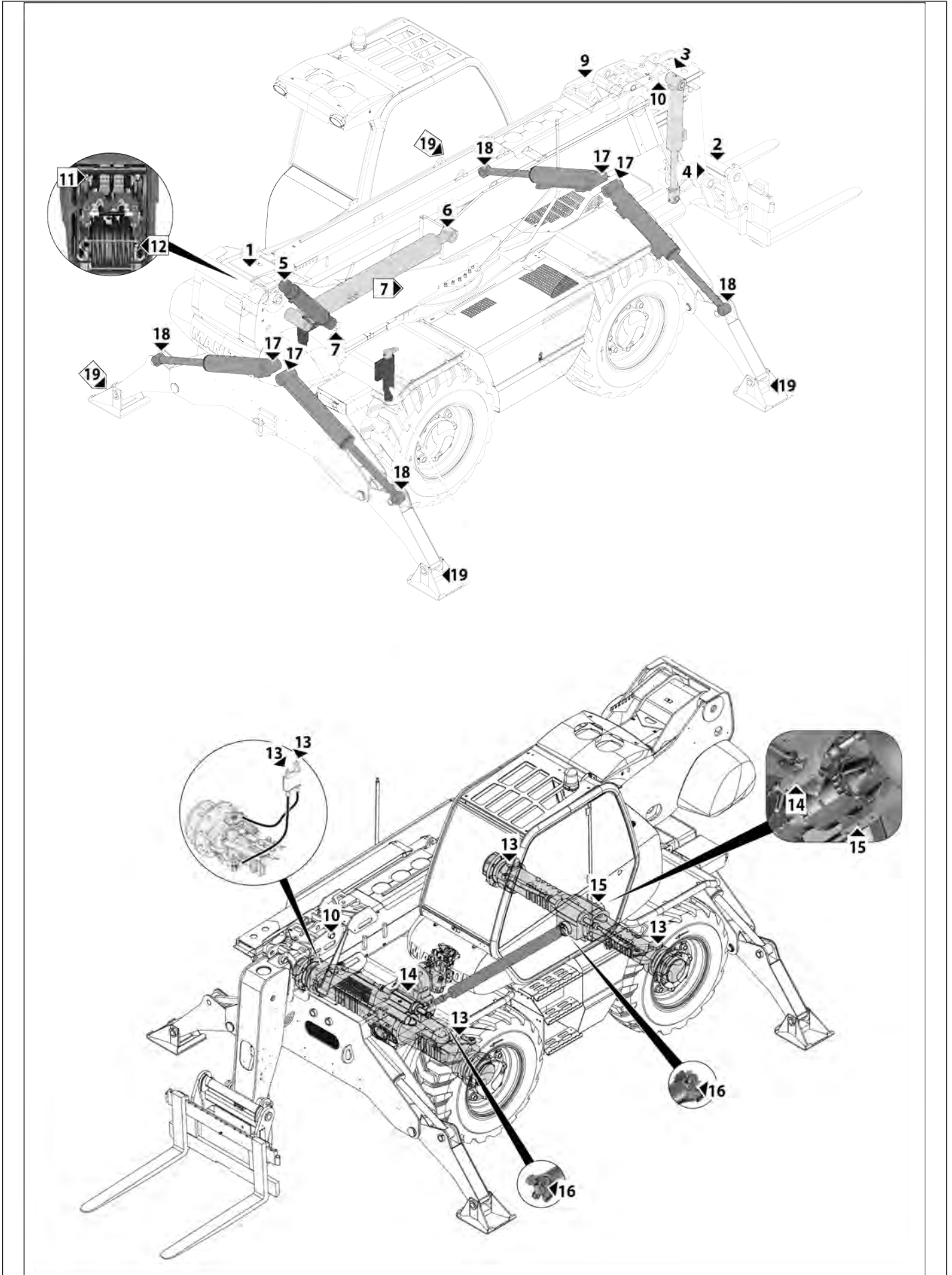


Figure 248: MRT-X / MRT 1645 — MRT-X / MRT 1845

**Overview of greasing points (example):**

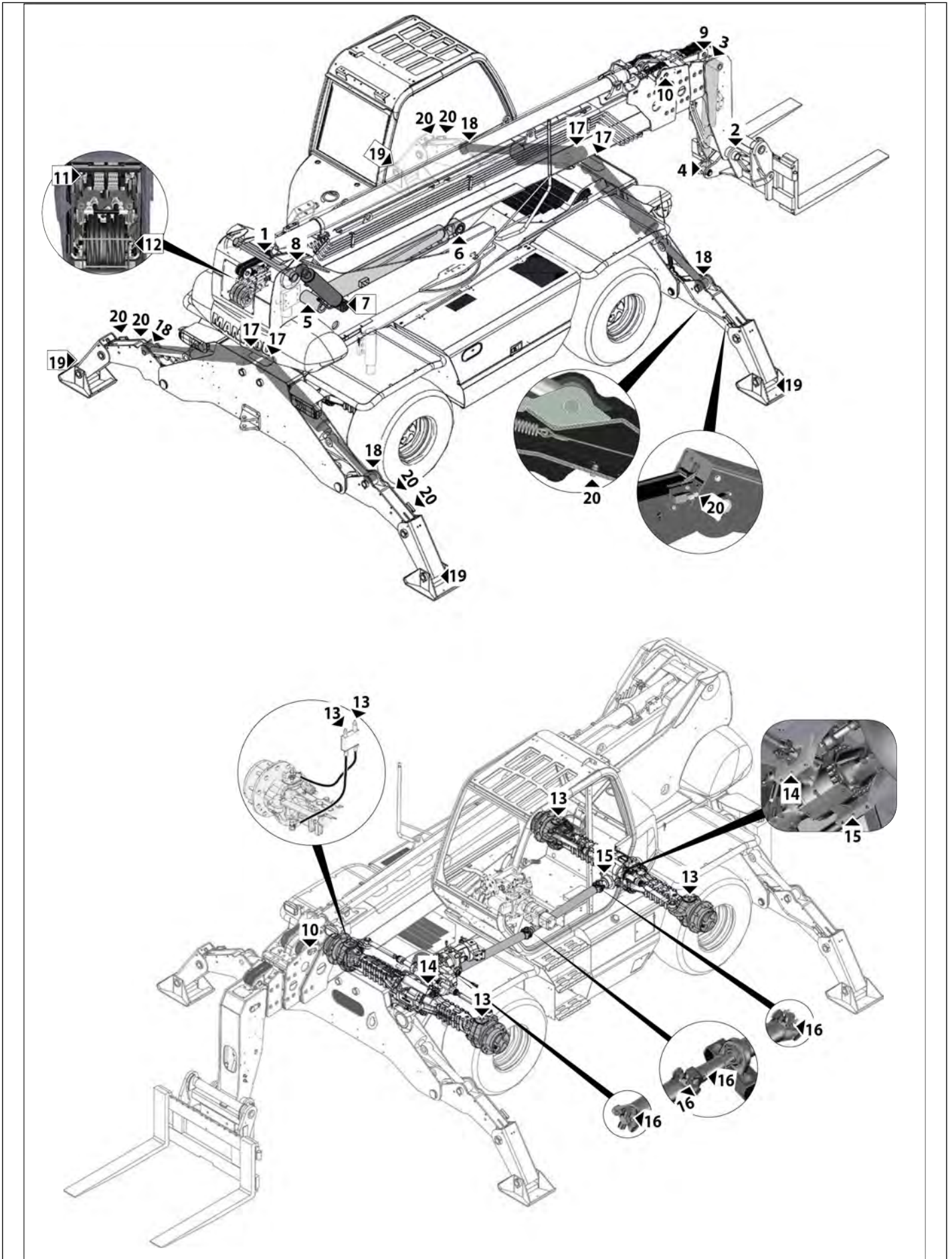


Figure 249: MRT-X / MRT 2145 — MRT-X / MRT 2545

#### 4.4.7 CLEANING AND LUBRICATION OF THE TELESCOPIC BOOM WEAR SHOES

1. Fully extend the telescopic boom.
2. Clean the surface of the extension arms.
3. Using a brush, apply a coat of grease to the 4 sides of the telescopic boom.
4. Extend and retract the telescopic boom several times to distribute the grease evenly.
5. Remove excess grease.



#### 4.4.8 CLEANING AND LUBRICATION OF THE TURRET ROTATION FIFTH WHEEL

##### Turret rotation fifth wheel bearing lubricators

- Clean and lubricate the turret rotation fifth wheel.
  - Rolling system lubrication. The fifth wheel is externally equipped with grease nipples (1) for the lubrication of the rolling system. Clean the grease nipples and proceed with lubrication so that a film of fresh grease is seen coming out along the entire periphery of the labyrinths or from the protective seals.

##### Toothing lubrication

- There must always be a film of grease on the toothing (2), lubricate manually with a brush.

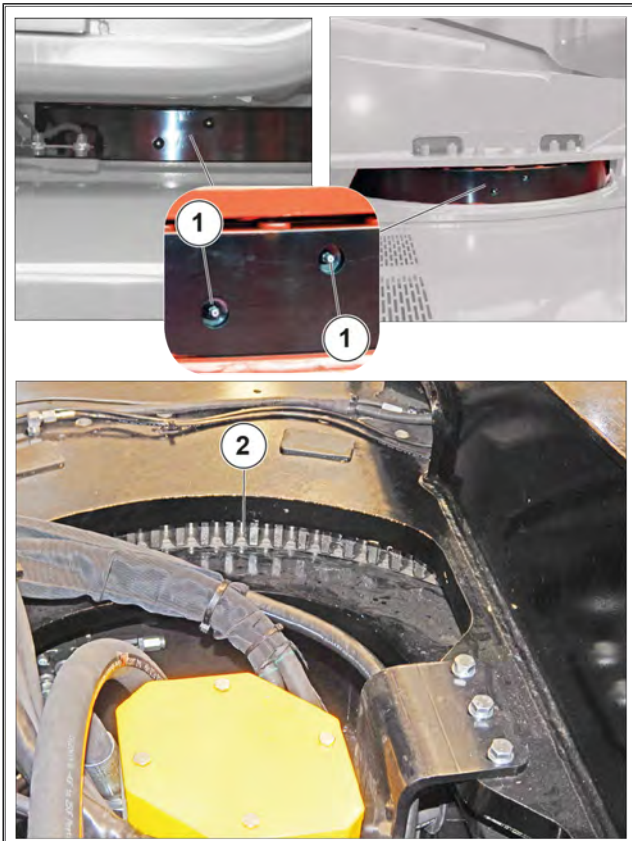


Figure 250: Cleaning and lubrication of the turret rotation fifth wheel

## 4.5. EVERY 250 HOURS OF OPERATION OR EVERY 6 MONTHS

### 4.5.1 FRONT AND REAR AXLE DIFFERENTIAL OIL LEVEL CHECK

Place the telehandler on a horizontal surface with the engine stopped.

Check the oil level of the front axle differential.

Remove the level plug (1) and top up (2), the oil must surface at the mouth of the hole.

If necessary, add fresh oil through the hole.

Repeat this for the rear axle differential.

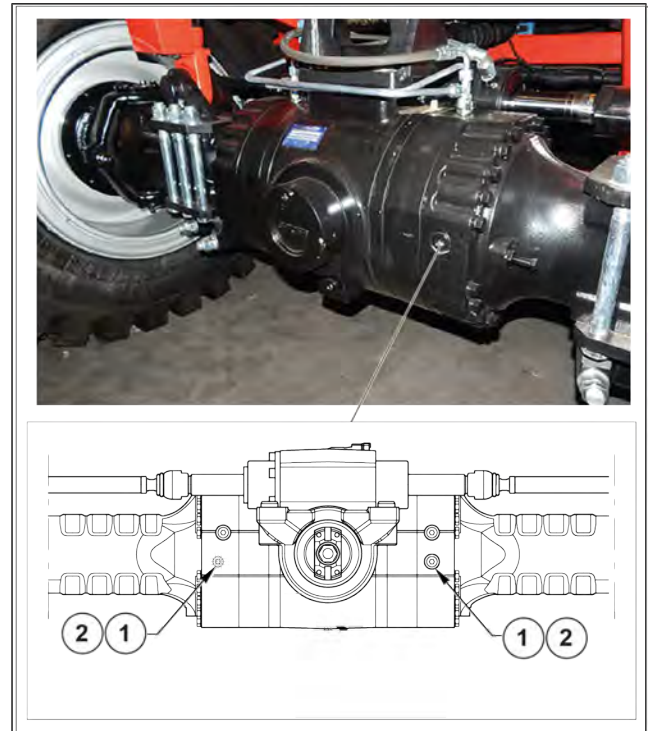


Figure 251: Front and rear axle differential oil level check

### 4.5.2 FRONT AND REAR WHEEL REDUCER OIL LEVEL CHECK

Place the telehandler on a horizontal surface with the engine stopped.

Check the oil level of the front axle differential.

Remove the level plug (1) and top up (2), the oil must surface at the mouth of the hole.

If necessary, add fresh oil through the hole.

Put back and tighten the level and filler cap (1).

Repeat this for the rear axle differential.



Figure 252: Front and rear wheel reducer oil level check

### 4.5.3 GEARBOX OIL LEVEL CHECK

Place the telehandler on a horizontal surface with the engine stopped and the gearbox oil still warm.

1. Remove the level and filler plug (1):  
the oil must rise to the surface of the hole.  
If necessary, add fresh oil.

2. Put back and tighten the level and filler plug (1).

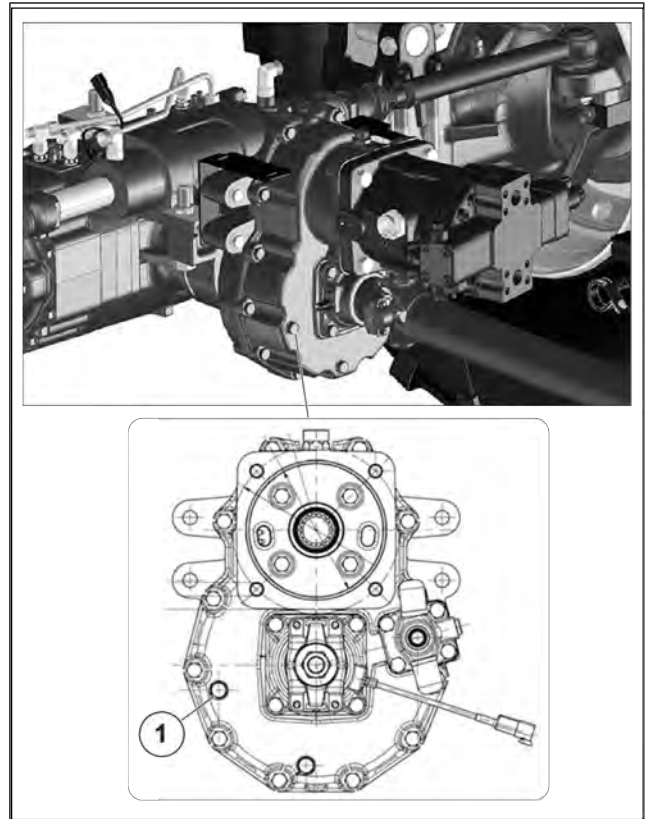


Figure 253: Gearbox oil level check

### 4.5.4 BATTERY CHECK

#### ⚠ WARNING

#### Danger of corrosive substances

Operate the battery switch (4) at least 30 seconds after cutting off the electrical contact using the ignition key (1). Handling and maintaining a battery can be dangerous. Take the following precautions: Wear protective goggles. Handle the battery horizontally. Never smoke or work near a flame. Work in a sufficiently ventilated room. If the electrolyte comes into contact with the skin or eyes, rinse thoroughly with cold water for 15 minutes and consult a doctor.

Check the battery electrolyte level every 250 hours.

When necessary, to restore the level add only distilled water. You should never add sulfuric acid.

If frequent topping up of distilled water is required, or if the battery is subject to frequent discharge, the voltage of the regulator must be checked, which must be between 13 V and 14.7 V, with the engine at maximum speed.

Check from time to time that the connection terminals are not oxidized.

If the vehicle is not used for a long time, disconnect the battery.

In case of high ambient temperature, check the level more frequently.

### Maintenance

1. Open the engine cover (3).
2. Check the connection clamps (2).
3. Check the electrolyte (1) level regularly.
  - If necessary, top up with demineralized or distilled water. Never top up with sulfuric acid.
  - If the pole voltage of the battery is less than 12.3 V (electrolyte density <1.21), the battery must be recharged.
  - If the vehicle is not used for a long time, disconnect the battery.

### Charging the battery

1. Remove the caps (1).  
The batteries should only be charged with direct current.
2. Connect the positive (+) cable of the battery charger to the positive (+) pole of the battery and the negative (-) cable of the battery charger to the negative (-) pole of the battery.
3. Charge with current equal to 1/10 of the nominal capacity (Ah) of the battery.  
The battery will be fully charged when the acid density is 1.28 (1.23 for tropical countries).
4. After charging, turn off the charger before disconnecting the battery.
5. Check the electrolyte level.

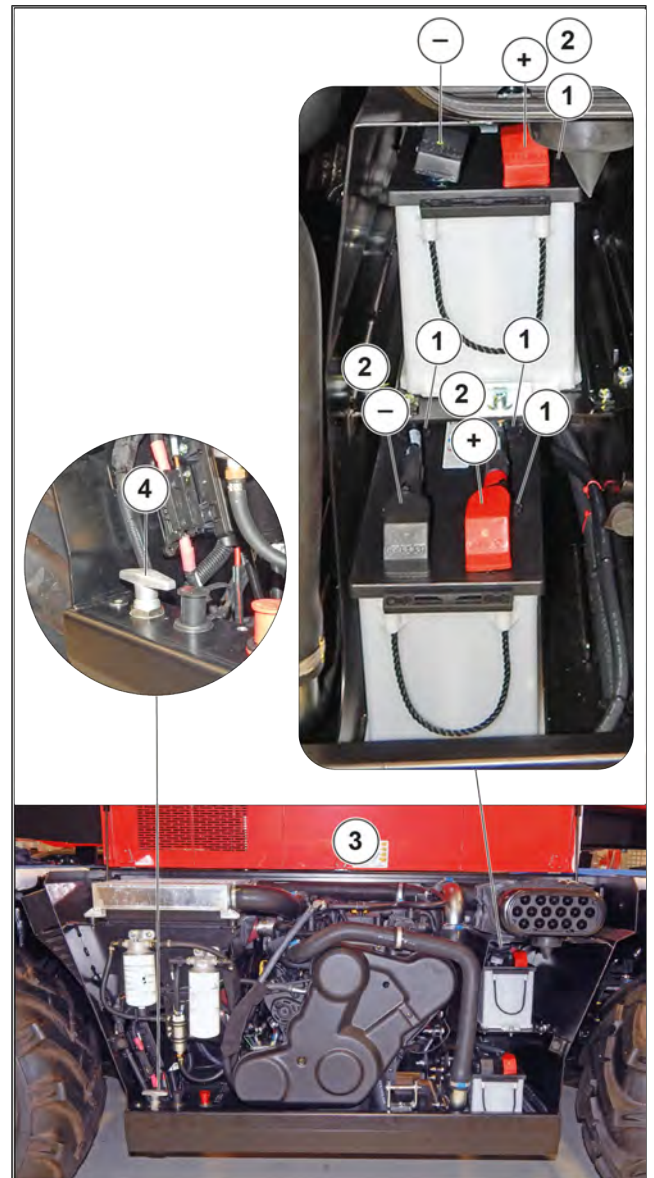


Figure 254: Battery check

### 4.5.5 ROTATION REDUCER FIXING SCREW TIGHTENING CHECK

**⚠ DANGER**

Raise the boom and place the safety wedge on the rod of the lifting cylinder.

Place the forklift on a horizontal surface with the engine stopped and the telescopic boom completely raised.

Visually check the fastening of the rotation reducer screws (1) to the chassis and in case of anomalies tighten the bolts according to the torque values described:

Tightening torque 200 Nm / 20.3 kgf-m.



Figure 255: Rotation reducer fixing screw tightening check

#### 4.5.6 EXTERNAL BOOM CHAINS CHECK

### ⚠ CAUTION

These checks are important for the correct operation of the boom.

If there is any malfunction, consult your dealer.

#### Clean and lubricate

1. Place the telehandler on the stabilizers, with the boom horizontal.
2. Fully extend the telescopic booms.
3. Protect the upper part of the telescopic boom.
4. Wipe the external boom chains with a clean cloth
5. Examine the chains carefully for any signs of wear.

6. Brush the chains vigorously to get rid of any foreign bodies.
7. Use a nylon brush.
8. Then rinse the chains with a brush impregnated with new diesel oil and dry them with a jet of compressed air.
9. Moderately lubricate the chains, and carry out some telescopic movements to check the behavior of the chains.

#### Chain tension control

Check the tension of the upper boom chains and, if necessary, re-tension them using a special wrench.

1. Place the telehandler on the stabilizers, with the boom horizontal.
2. Fully extend the telescopic booms.

3. Make sure that the chains have remained under tension (keep the boom extraction lever pressed for a few seconds).
4. Measure the distance between the lower side of the chain and the boom (T1-T2) with the aid of a gage or ruler.

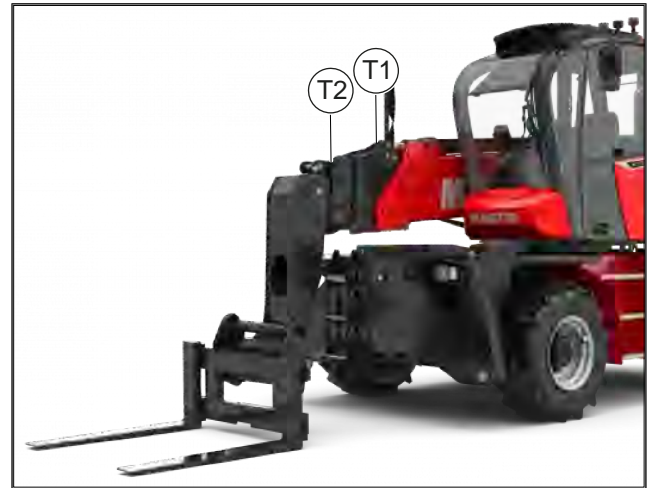


Figure 256: MRT-X 1845, MRT 1845

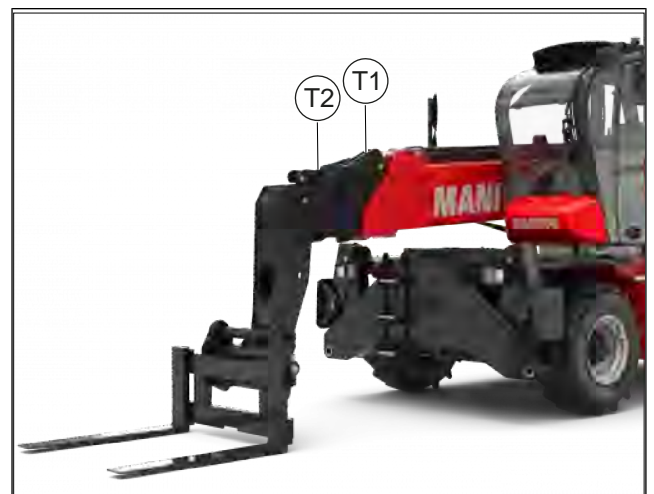


Figure 257: MRT-X 2145, MRT 2145, MRT-X 2545, MRT 2545

5. If the resulting values are lower than those in the table below, proceed to register the chains (T1-T2).

Table 200. Chain registration value table

			<b>MRT 1845 / MRT-X 1845 MRT 2145 / MRT-X 2145</b>	<b>MRT 2545 / MRT-X 2545</b>
<b>1st extension boom (T1)</b>			mm - in	
Minimum size	Y1	≥	80 - 3.1	97 - 3.8
Maximum size	Y2	≤	100 - 3.9	117 - 4.6
<b>2nd extension boom (T2)</b>			mm - in	
Minimum size	X1	≥	80 - 3.1	65 - 2.5
Maximum size	X2	≤	100 - 3.9	85 - 3.3

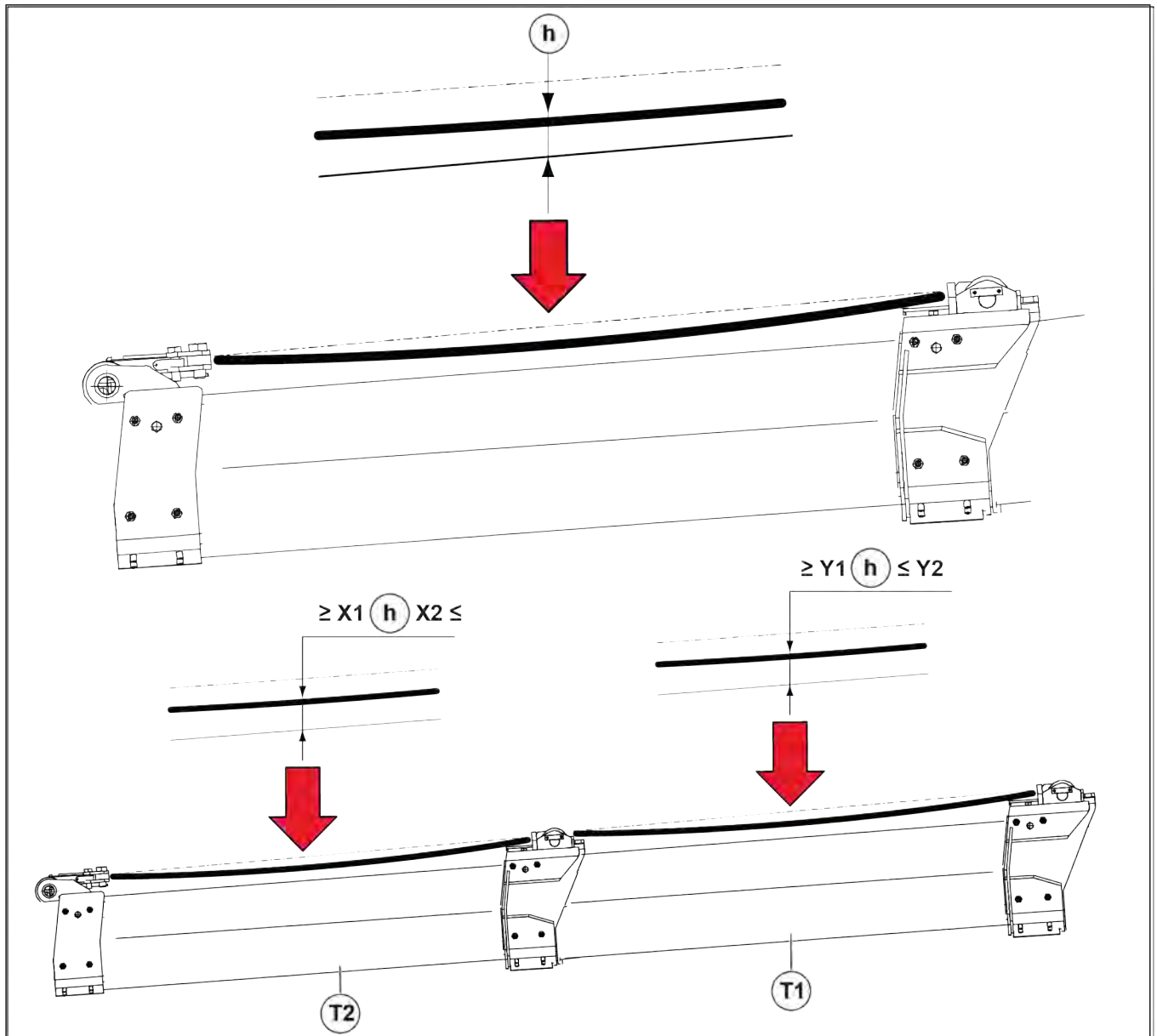


Figure 258: Chain tension control T1 - T2

### Registering the tension of the chains

Proceed to adjust the tension of the chains by acting with a special key on the tie rods on the boom (extension chains) (1).

If the play on the chains is excessive it may happen that the arm extensions do not retract completely.

Check and adjust if necessary the internal chain tie rods (2) for correct retraction of the extensions.

### **CAUTION**

If the problem persists, consult your agent or dealer.

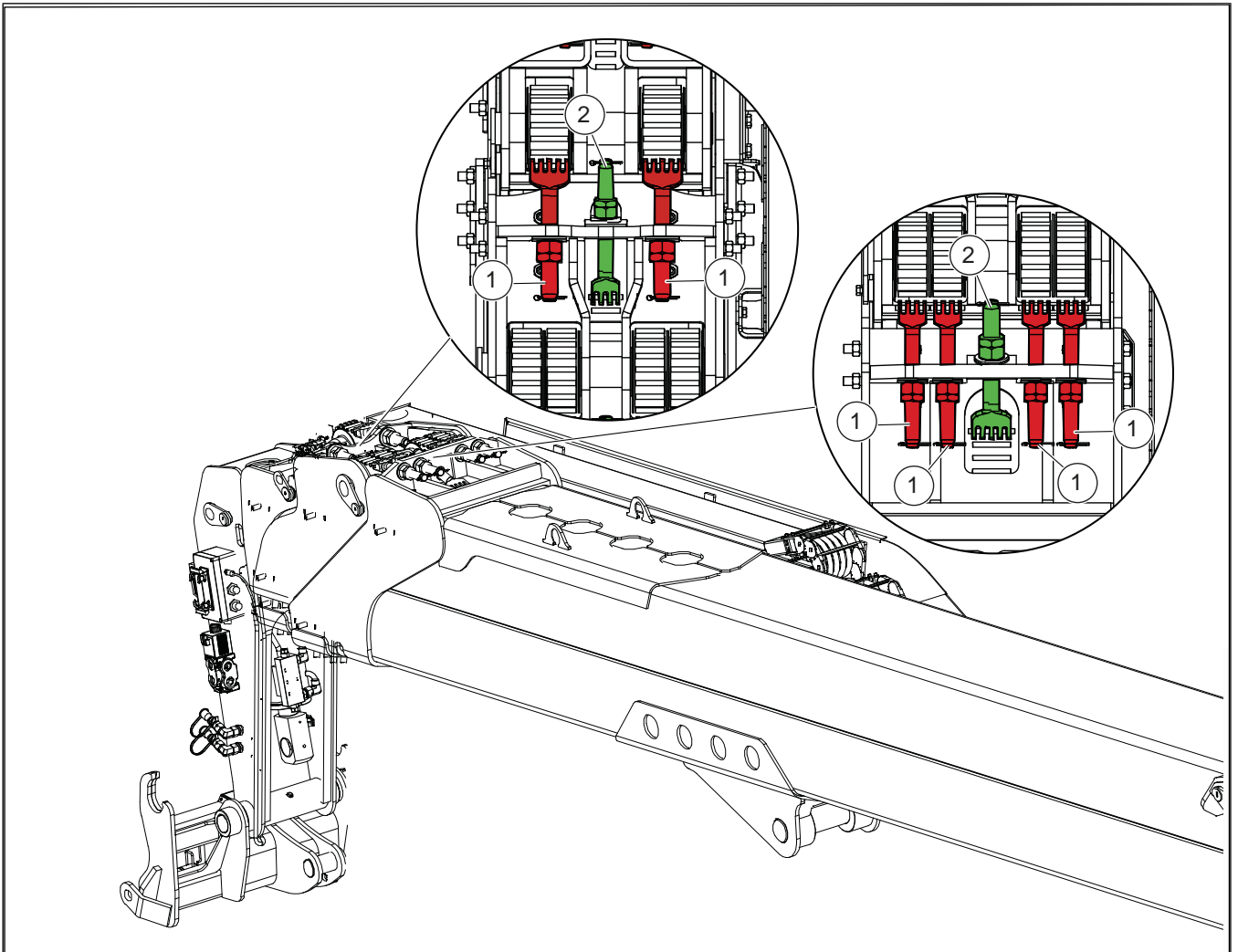


Figure 259: Adjustment of the tension of the chains T1 - T2

### 4.5.7 CHECKING STABILIZERS LOWERING AND RAISING SYSTEM

The machine is equipped with four independently controlled stabilizers.

For the correct operation of the raising and lowering movements of each stabilizer (1), visually check the integrity and condition of the following components:

- 1 eyebolt (2).
- 1 tie rod (3a) + wire rope (3b) + traction spring (3c).
- 1 rope guide shoe (4).
- 1 contact plate under the stabilizer foot (5).

- 1 magnet (6a) and counterpart (6b) for locking the stabilizer booms.

**⚠ DANGER**

**Do not attempt to replace or repair without the presence of a Manitou qualified person.**

Any tampering not authorized by Manitou will void the warranty.  
Contact your agent or dealer immediately if any faults are found.



Figure 260: Checking stabilizers lowering and raising system

## 4.6. EVERY 500 HOURS OF OPERATION OR EVERY 1 YEARS

### 4.6.1 HYDRAULIC OIL CONTAMINATION CHECK

MANITOU offers a hydraulic oil analysis kit that can allow you to extend the recommended period of periodic maintenance (2000 hours). In this case it is recommended to perform a hydraulic oil analysis every 500 hours of operation or 1 year.

The oil analysis kit also allows to validate the quality of the oil to reach the 2000 hour expiry in the case of specific uses that generate stress on the hydraulic circuit: extreme environmental conditions, use of attachments that require enormous hydraulic flow (sweeper, mixer).

- Order an oil analysis kit from your dealer.

- Once you have received the kit, take a sample and follow the recommendations indicated inside the kit itself.
- Keep the analysis report or change the hydraulic oil according to the results.

**Oil analysis kit (MANITOU reference: 958162).**



Figure 261: Hydraulic oil contamination check

### 4.6.2 REPLACING THE HYDROSTATIC PUMP OIL FILTER (TRANSMISSION)

Only for Rexroth pumps

**⚠ WARNING**

#### Danger of intoxication and injury

Contact with hydraulic fluid is harmful to health (e.g. eye, skin and tissue damage, poisoning by inhalation). While working with hazardous materials (for example, hydraulic fluids), always wear protective gloves and goggles.

Place the telehandler on a flat surface and stop the engine.

#### Replace the filter

To replace the filter cartridge and filter gasket:

- Loosen and remove the filter housing (4) from the filter head (1).
- Remove the used filter cartridge (3) from the filter housing (4).
- Check the filter head and filter housing for damage, wear and contaminants.
- Insert the new filter cartridge (3) into the filter housing (4).
- Check the O-ring and O-ring groove for damage, wear, or contaminants.

- Replace the O-Ring (2) with a new one. Lightly grease the O-ring.
- Screw the container filter (4) onto the filter head (1). Tighten the filter housing (4) with 45 Nm / 4.58 kgf-m.

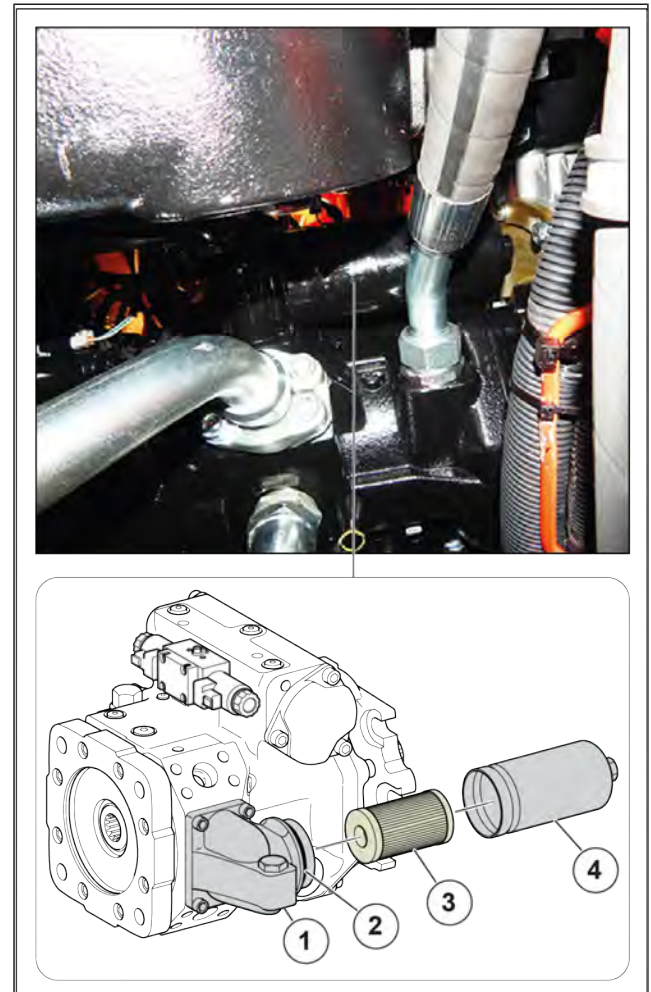


Figure 262: Replacing the hydrostatic pump oil filter (transmission)

### 4.6.3 REPLACING THE HYDRAULIC OIL FILTER CARTRIDGE (DRAIN)

- Remove the tank compartment top panel (1) to access the hydraulic oil drain filter cartridge.
- Loosen the 4 fixing screws (2) of the filter cover (3). Remove the used cartridge (4) and replace it with a new one with the same characteristics (4).
- Refit the filter cover (3) and tighten the 4 fixing screws (2).
- Refit the upper panel (1) of the fuel tank compartment.

**⚠ DANGER**

Before screwing the filter cover (3) back on, check that the cartridge (4) is fitted correctly.

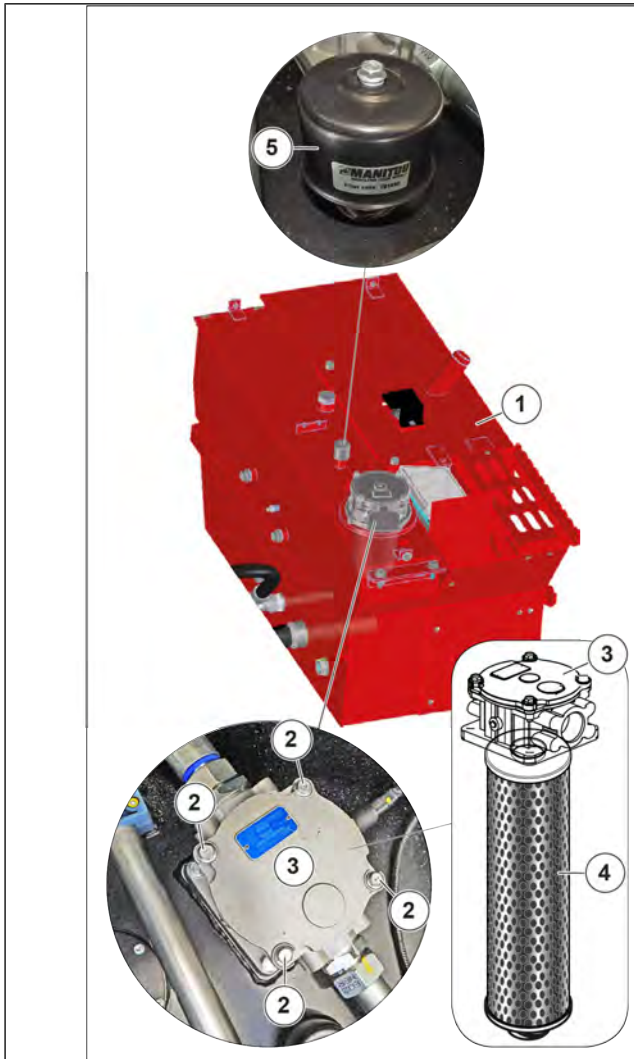


Figure 263: Replacing the hydraulic oil filter cartridge (drain)

#### 4.6.4 REPLACING THE HYDRAULIC OIL BREATHER

- Remove the upper panel (1) of the tank compartment to access the breather (2).
- Unscrew the breather (5) on the hydraulic oil tank and replace it with a new one with the same characteristics.

- Fit the new breather (5) tightening it by hand.
- Refit the upper panel (1) of the fuel tank compartment.

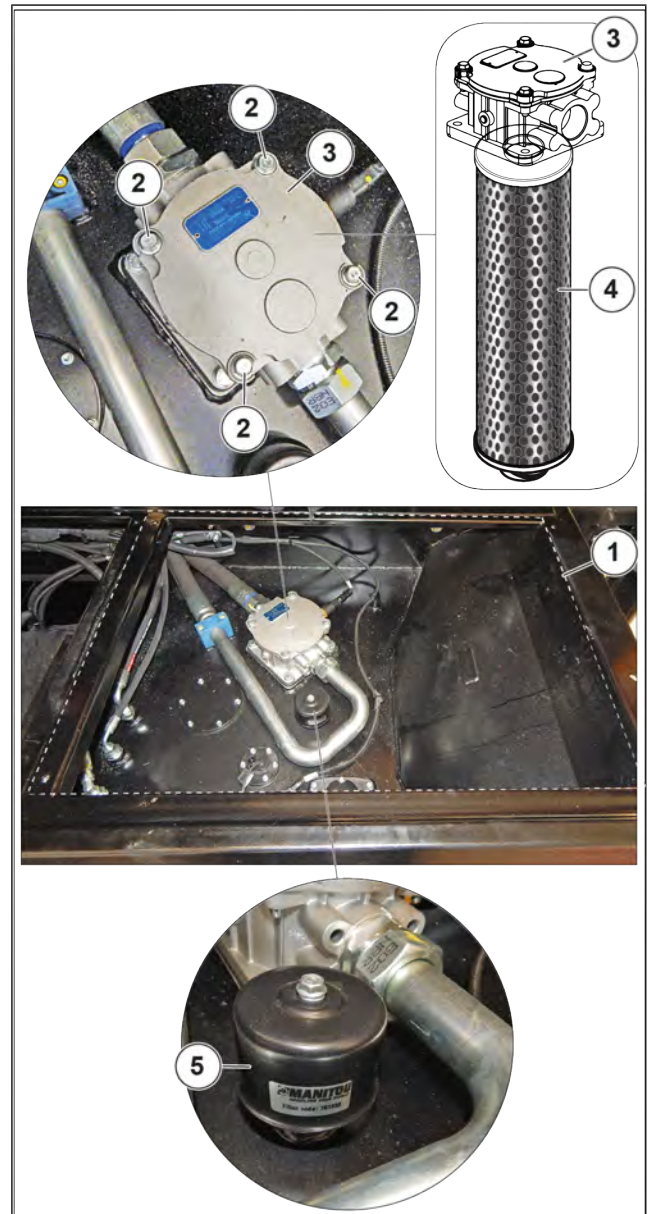


Figure 264: Replacing the hydraulic oil breather

#### 4.6.5 CABIN VENTILATION FILTERS CHECK

1. Stop the engine.
2. Remove the air intake (1) fixed on the cover behind the cabling to access the primary (2) and secondary (3) ventilation filters.
3. Remove the grille (4) that protects the filters (2 and 3) by unscrewing the knob (5).
4. Remove the primary filter (2).
5. Remove the secondary filter (3) by pulling it from the flap (3a).
6. Then clean the filters with a jet of compressed air.
7. Check the condition of each filter (2 and 3) and replace it if necessary.
8. Reposition the secondary filter (3) and then the primary filter (2) in its seat.
9. Refit the grille (4) that protects the filters (2 and 3) locking it by screwing the knob (5).

10. Refit and secure the air intake (1) on the cover behind the cabin.

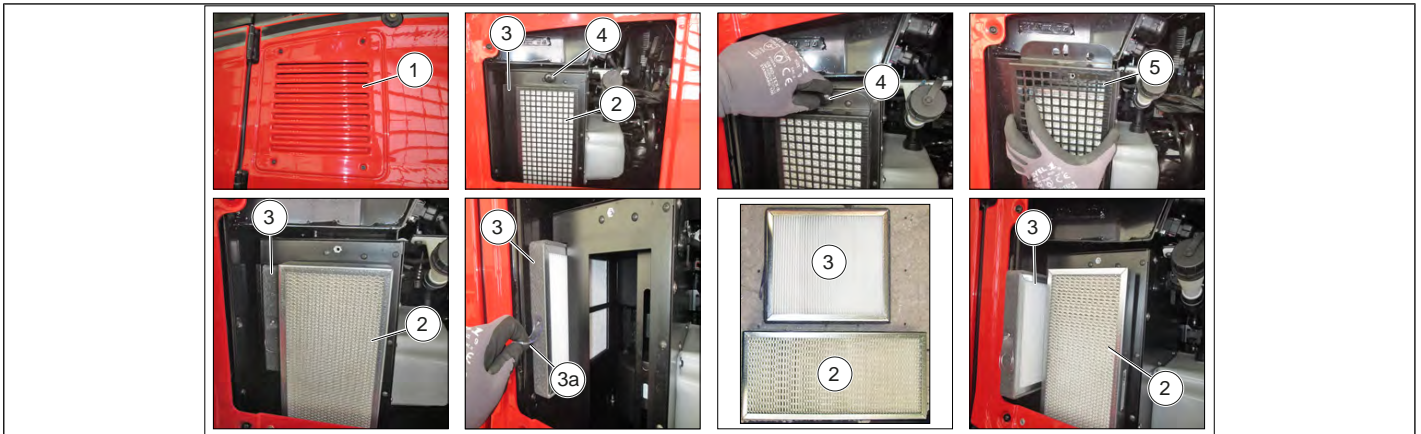


Figure 265: Cabin ventilation filters check

#### 4.6.6 FIFTH WHEEL AND TURRET FIXING BOLTS CHECK

**⚠ DANGER**

Raise the telescopic boom and place the safety wedge on the rod of the lifting cylinder.

- Place the telehandler on a flat surface, without load and stress from external forces.
- Stop the engine.
- Visually check the correct tightening of the fifth wheel and turret bolts (2). In case of anomalies, tighten the bolts according to the tightening torque values: 450 Nm / 45.8 kgf.

To tighten the fifth wheel bolts (2) that secure it to the chassis, it is necessary to pass through the holes above the turret (1a). Remove the caps (1) to access the bolts (2).

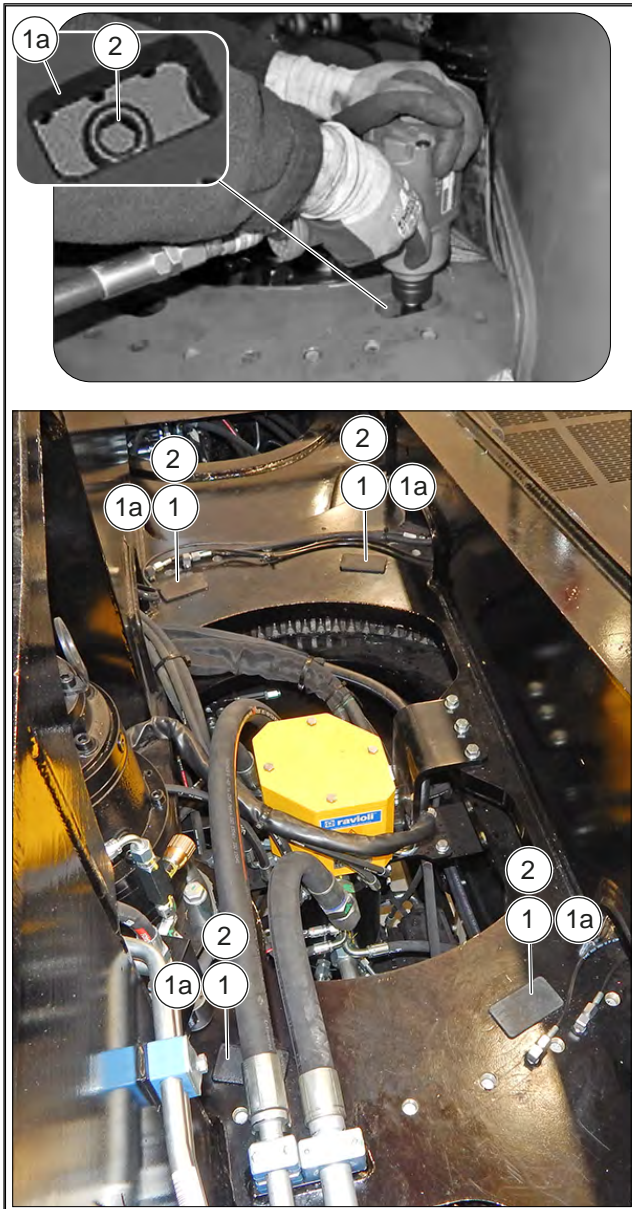


Figure 266: Fifth wheel and turret fixing bolts check

#### 4.6.7 CHECKING THE V-BELT TENSION

### **⚠ DANGER**

Perform the operations on the belt drive with engine stopped. After repairs: make sure that all the protective devices have been reassembled and that no tools have been forgotten on the engine. Replace the belt drives if they are damaged.

- Check the correct positioning of the new belt and check the tension after 15 min. of operation.

- Remove the protection device 1.
- Check the belt drive 2 section by section for damage (see: Damage types).
- Immediately replace the belt drive if there are signs of damage.

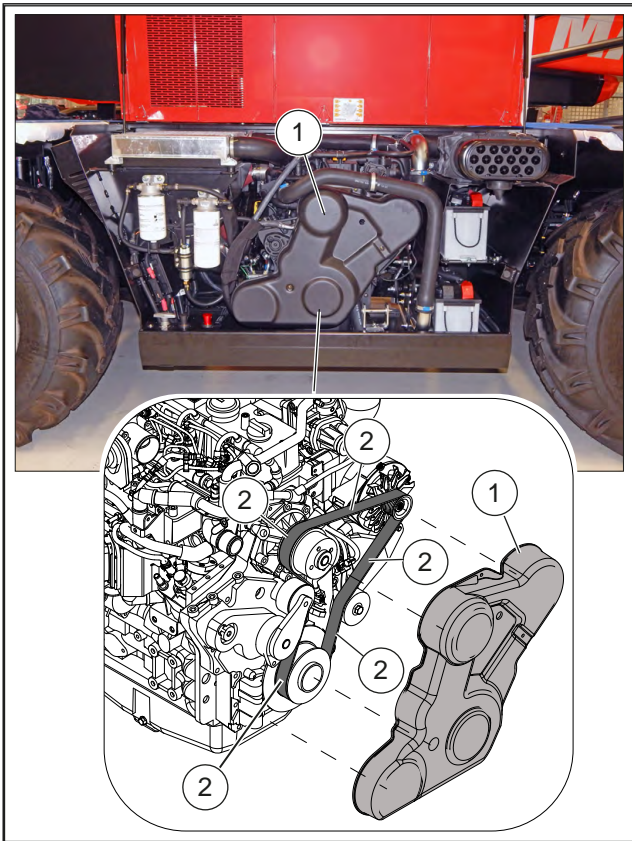


Figure 267: Checking the V-belt tension

Damage types

1. New belt (for comparison; trapezoidal ribs).
2. Wear on the sides: wedge-shaped ribs.
3. Structure visible at the bottom of the rib.
4. Broken ribs.
5. Cross cracks in different ribs.
6. Rubber nodules at the bottom of the belt.
7. Deposits of dirt or rubble.
8. Ribs detached from the bottom of the belt.
9. Structure wires torn off laterally.
10. External wires of the structure frayed.
11. Cross cracks on the back.
12. Cross cracks in different ribs.

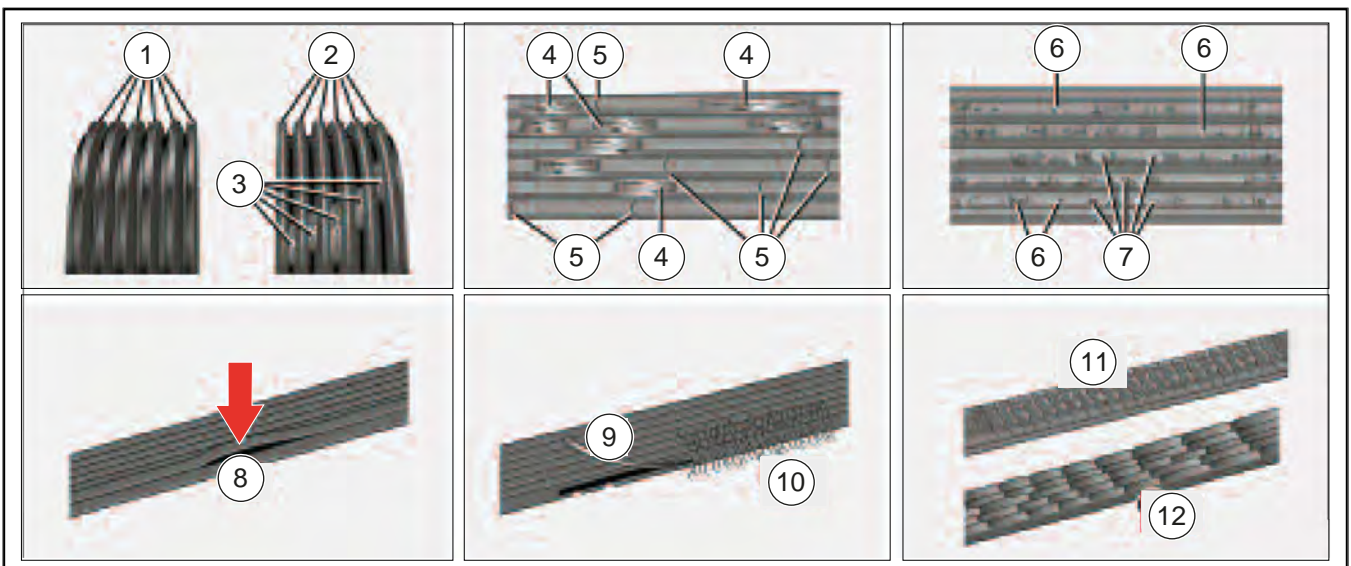


Figure 268: Damage types

### 4.6.8 FORKS WEAR CHECK

Contact your dealer.

## 4.7. EVERY 1000 HOURS OF OPERATION OR EVERY 2 YEARS

### 4.7.1 FRONT AND REAR AXLE DIFFERENTIAL OIL CHANGE

Place the telehandler on a level surface with the engine stopped and the differential oil still warm.

- Place a container under the drain plug (1) and let the oil drain out.

- Remove the level and filler plug (2) to ensure complete emptying.
  - Fit and tighten the cap (1). Fill the oil through the filling hole (2).
  - The level is correct when the oil emerges from the level hole (2).
  - Check for leaks from the drain plugs (1).
  - Fit and tighten the level and filler plug (2).
- Do the same for the front and rear differential.

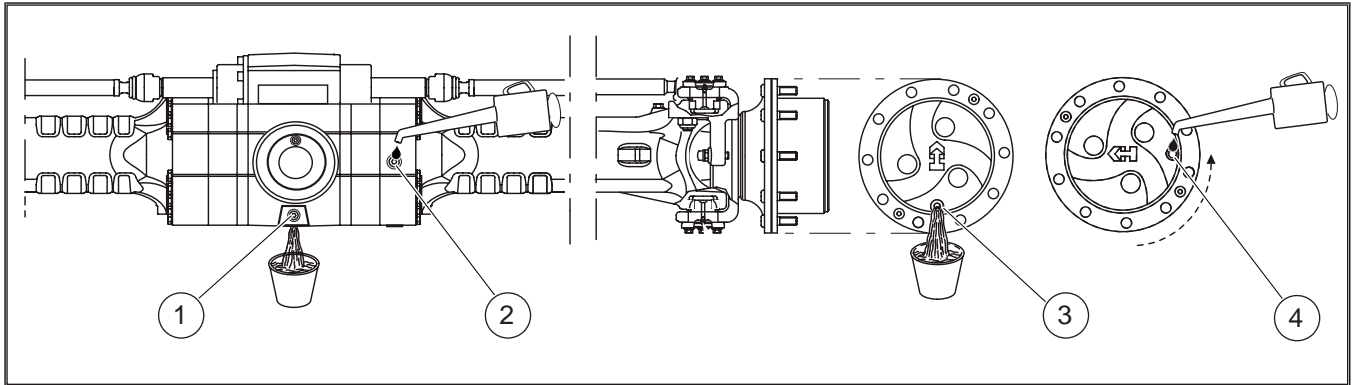


Figure 269: Front and rear axle differential oil change

#### 4.7.2 CHANGE FRONT AND REAR AXLE FINAL REDUCER OIL

Place the telehandler on a flat surface with the engine stopped and the gearbox oil still warm.

- Make sure that the drain and level plug (3) of the reducer is oriented downwards to allow the oil to drain better.
  - Place a container under the drain plug (3) and unscrew it. Let all the oil drain out. Bring the outlet hole to a horizontal position (4) in order to subsequently check the oil level.
  - Refill with new oil through the level hole (4). The level is correct when the oil emerges from the hole (4).
  - Replace the drain plug 3 and tighten it.
- Repeat this for each final drive.

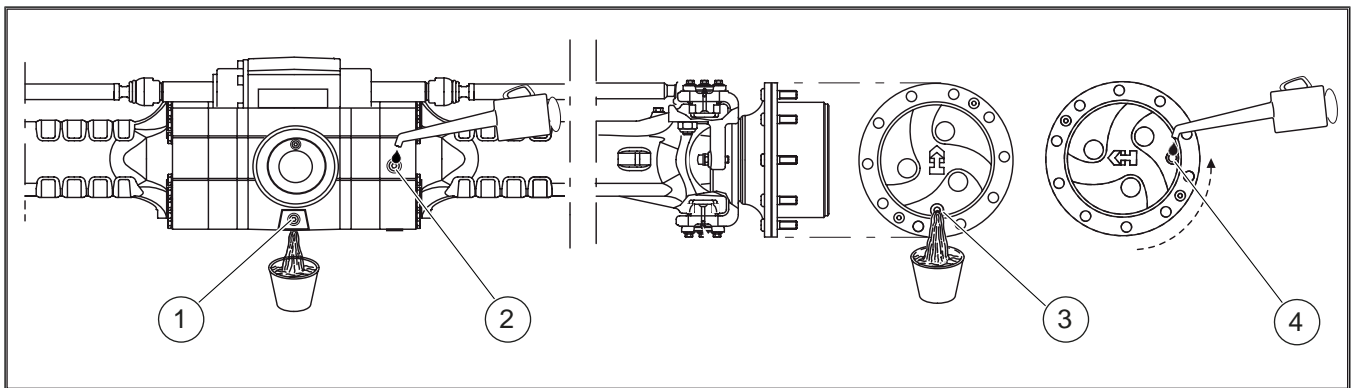


Figure 270: Change front and rear axle final reducer oil

#### 4.7.3 GEARBOX OIL CHANGE

Place the telehandler on a level surface with the engine stopped and the gearbox oil still warm.

- Place a container under the drain plug (1).
  - Remove the drain plug (1) and let the oil drain out.
  - Remove the level and filler plug (2) to ensure complete emptying. Put back and tighten the cap (1).
  - Fill with new oil through the level and fill hole (2). The level is correct when the oil comes out of the hole.
  - Put back and tighten the level and filler plug (2).
- Check for any leaks from the drain plug.

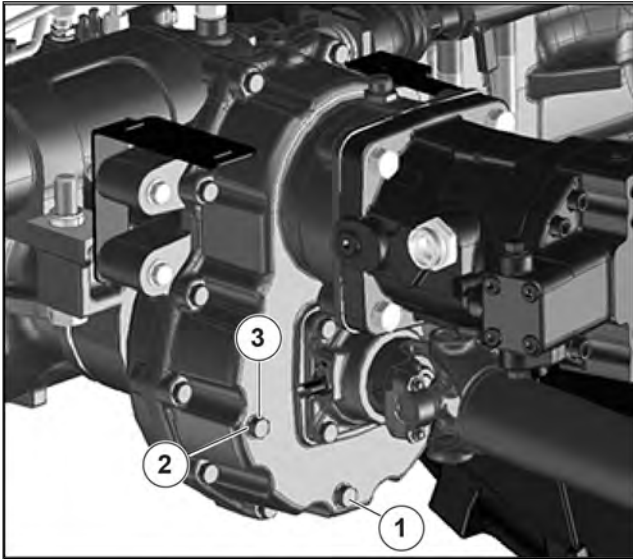


Figure 271: Gearbox oil change

- Check the condition and fastening of the connecting pipes to the heat engine, and the connection and conditions of the filter clogging indicator.
- Before assembly, check the condition of the new filter cartridge (4).
- Tilt the cartridge about 5° forward, insert it into the filter and position it by pressing on the edge of the cartridge and not in the center.
- Refit the cover and check the correct locking of the clips. The cover must be installed without difficulty, otherwise check the correct positioning of the cartridges in the filter.


#### 4.7.4 DRY AIR FILTER CARTRIDGE REPLACEMENT

In case of use in a very dusty atmosphere, the cartridge replacement intervals must be reduced (up to 250 hours in a very dusty atmosphere).

### **⚠ DANGER**

Replace the cartridge in a clean environment and with the heat engine off. Never use the vehicle with a disassembled or damaged cartridge. If the air filter service indicator



comes on , replace the cartridge as soon as possible (maximum 1 hour). Never use the vehicle without the air filter, or with a damaged air filter.

- To access the engine air filter housing (5), open the engine cover (6), unscrew the knobs (7a) and remove the panel (7) to access the filter cartridge.
- Release the blocks and remove the cover (1).
- Carefully rotate the cartridge (2) forward to minimize dust escaping.
- Remove the cartridge (3).
- Do not remove the safety cartridge.
- Carefully clean the following parts with a damp, clean, lint-free cloth.
  - The inside of the filter and lid.
  - The inside of the filter inlet pipe.
  - The seats of the gaskets in the filter and in the cover.

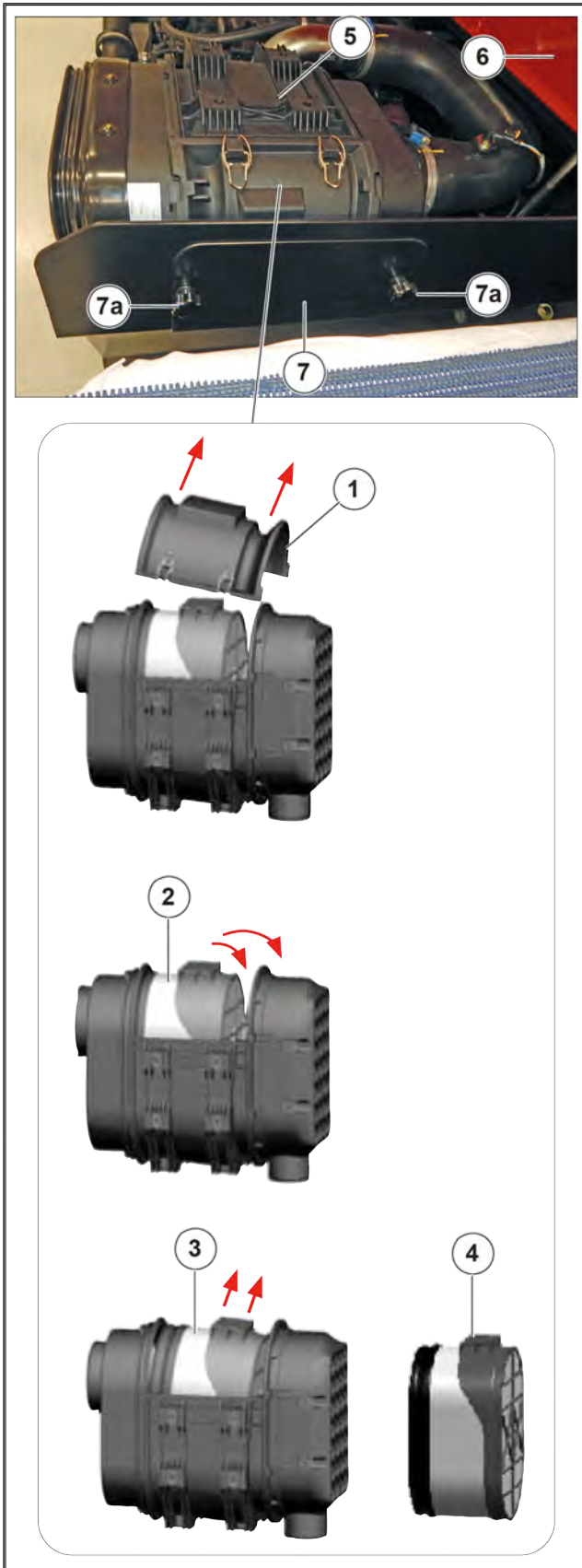


Figure 272: Dry air filter cartridge replacement

#### 4.7.5 CLEANING THE FUEL TANK

### ⚠ DANGER

Fuels are highly flammable, so the risk of fire is high. During the handling of fuels, it is forbidden to smoke, approach naked flames and unprotected light and carry out interventions that cause the formation of sparks.

- Place the telehandler on a horizontal surface, lower the stabilizers as far as possible to increase the ground clearance of the machine.
- Stop the engine.
- Turn the ignition key to position "0".
- Close the water separator fuel valve.
- Unscrew the tank filler cap (2) then place a suitable container under the drain plug (1) and unscrew the cap.
- Let the fuel flow out of the hole (3) and pour 10 liters of clean fuel through the filler neck (4) to eliminate any impurities.
- Refit and tighten the drain plug (1).
- Fill the tank with clean fuel and replace the fill cap (2).

### ⚠ DANGER

Do not fill the tank completely. As it warms up, the fuel expands. It could overflow from the tank.

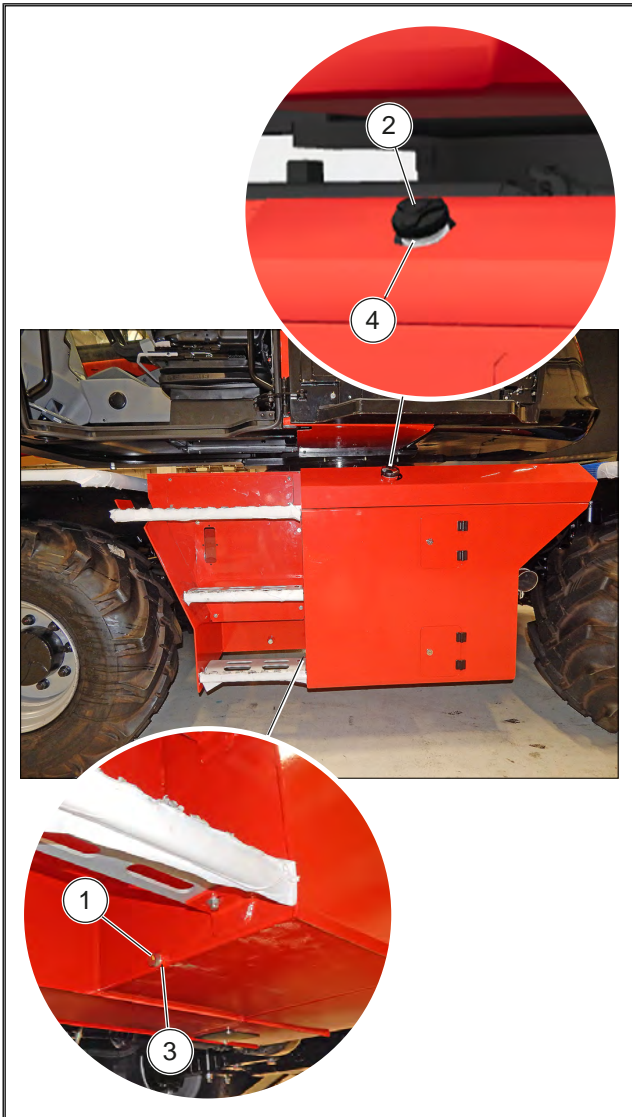


Figure 273: Cleaning the fuel tank


### 4.7.6 FUEL PRE-FILTER REPLACEMENT

**⚠ DANGER**


Thoroughly clean the outside of the pre-filter as well as its holder to prevent dust from entering the system. Tighten the fuel pre-filter by hand only and lock it a quarter of a turn.

- Place the telehandler on a horizontal surface and stop the heat engine.
- Turn the ignition key to position "0".
- Open the engine cover (1) and locate the fuel pre-filter (6).
- Place a suitable collection container.
- Disconnect the electric connection (2).


- Loosen the drain screw (3).
- Discharge the liquid until pure diesel fuel starts to flow out.
- Replace the bleeder cap.

 *Tightening torque 1.6 Nm ± 0.3 Nm*

- Reconnect the electric connection (2).
- Remove the filter element (4).
- Clean the sealing surface of the new filter cartridge and the opposite side of the filter head (5) from any dirt.
- Lightly moisten the sealing surfaces of the filter cartridge with fuel and tighten the filter head clockwise.

 *Tightening torque 17 Nm - 18 Nm*

- Replace the bleeder cap (3).

 *Tightening torque 1.6 Nm ± 0.3 Nm*

- Vent the fuel system (see "Venting the fuel system").
- Vent the fuel distribution system.  
The fuel distribution system is automatically vented via the electric fuel delivery pump. To activate the process it is necessary to turn the ignition key to on and the electric fuel delivery pump is activated for 20 seconds to vent the fuel distribution system and generate the necessary fuel pressure.

**⚠ DANGER**

Wait until the electric fuel delivery pump has been disconnected from the control unit.

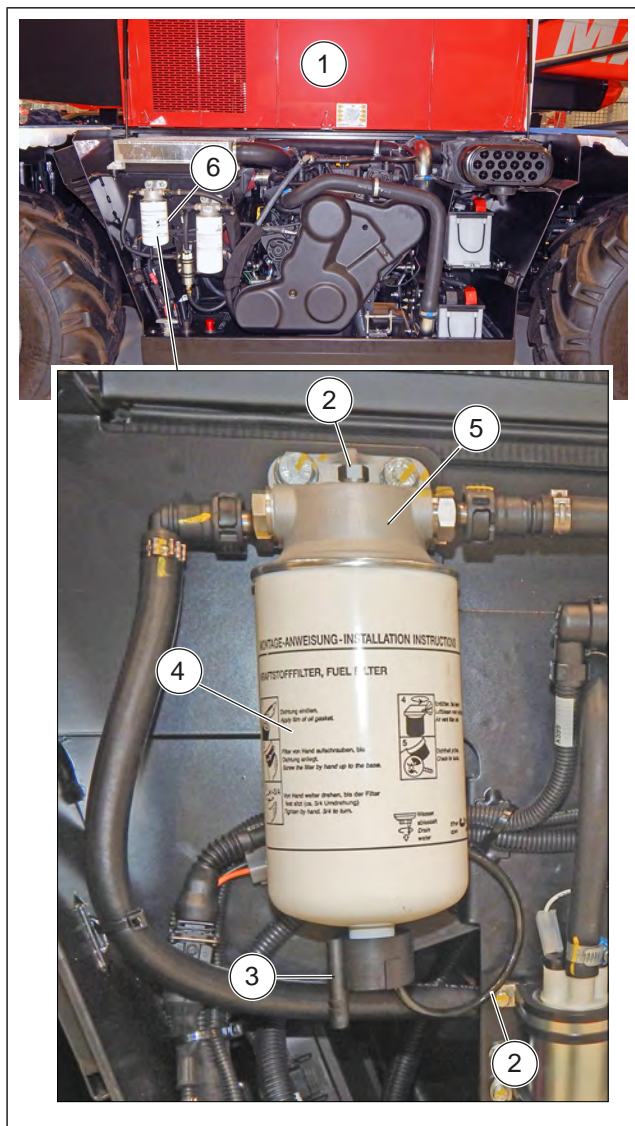


Figure 274: Fuel pre-filter replacement

#### 4.7.7 FUEL FILTER REPLACEMENT

### ⚠ DANGER

Thoroughly clean the outside of the filter as well as its holder to prevent dust from entering the system.

- Place the telehandler on a horizontal surface, stop the three-phase motor and let it cool down.
- Open the engine cover (1) and locate the fuel filter (6).
- Loosen the filter (2) with the tool (2a) and unscrew it.
- Collect any leaked fuel.
- Clean the sealing surface of the filter holder with a clean, lint-free cloth.

- Lightly oil the gasket (5) of the new filter (4).
- Manually screw the new filter (4) to tightness (3).



Tightening torque 10 Nm - 12 Nm

- Vent the fuel distribution system.

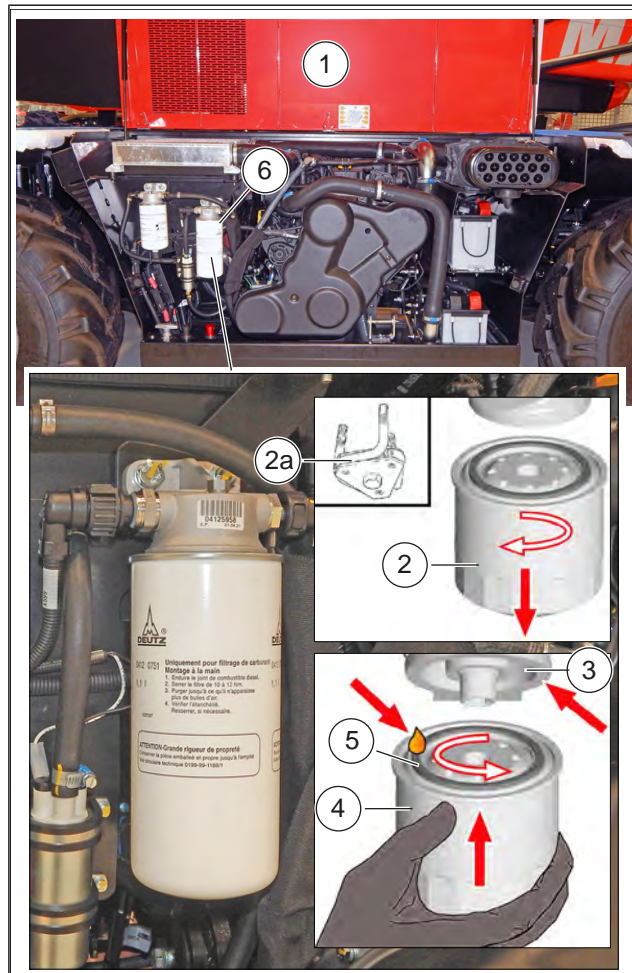


Figure 275: Fuel filter replacement

#### 4.7.8 ENGINE OIL AND FILTER CHANGE


- Place the telehandler on a level surface.
- Warm up the engine (lubricating oil temperature > 80 °C / 176 °F).
- Turn off the engine.
- Open the engine cover.


### ⚠ DANGER

Dispose of the used oil in an environmentally friendly manner. Hand tighten the oil filter and lock it in place by turning it by a quarter turn.

**DRAINING THE OIL**

- Remove the protection panel under the engine 1.
- Place a container under the oil drain screw 2.
- Loosen the oil drain screw 2 and drain the oil.
- Remove the filler cap 3 to make the draining operation easier.
- Screw and tighten the lubricating oil drain plug 2 with the new sealing ring.

 *Tightening torque 55 Nm / 5.6 kgf.*

 *When removing the doors and closing plates, clean all around and remove any buildup of flammable materials.*


**FILTER REPLACEMENT**

**▲ DANGER**

**Risk of contamination by dirt.**

Filter 4 must never be pre-filled.

- Loosen and remove the filter 4 with a suitable tool 4a.
- Collect the drained lubricating oil.
- Carefully wipe the sealing surface 4b of the filter holder with a clean, lint-free cloth.
- Lightly oil the gasket 5 of the new filter.
- Manually screw the new filter fully home and tighten it.

 *Tightening torque 10-12 Nm / 1-1.2 kgf.*

**FILLING WITH OIL**

- Fill with oil (and LUBRICANTS and FUEL) through the filler port 7.
- Warm up the engine (lubricating oil temperature > 80 °C / 176 °F).
- Check for any leaks from the drain plug and oil filter.
- Stop the engine, wait a few minutes and check the oil level 8.  
The oil level must always be between the MIN and MAX notches! Top up to the MAX mark if necessary.
- Refit the protection panel under the engine.

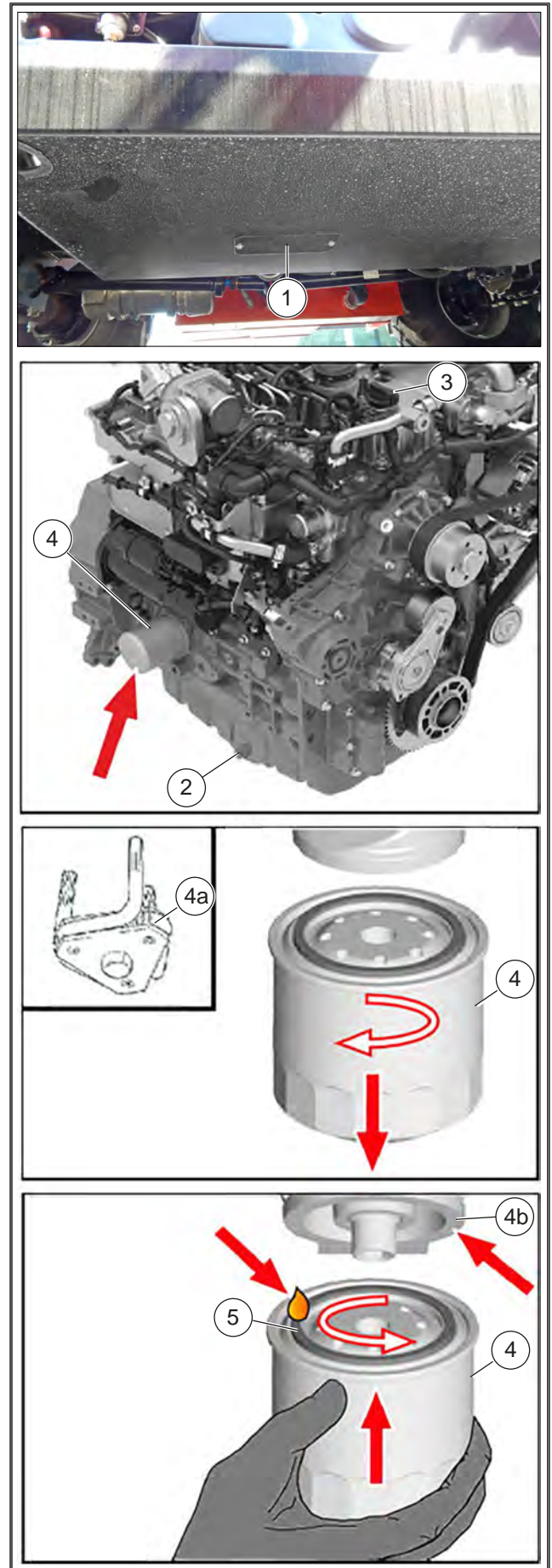


Figure 276: Engine oil and filter change

### 4.7.9 COOLANT REPLACEMENT

This series of operations must be carried out when necessary or at least once every 2 years when winter arrives. Place the telehandler on a level surface, with the heat engine off and cold.

#### **⚠ DANGER**

The three-phase motor does not contain any anti-corrosive elements and must always be filled with a minimum mixture of 25% ethylene glycol based antifreeze.

#### Coolant drain

Carry out work on the cooling system only if the coolant temperature is below 50° C.

- Open the engine cover.
- Slowly open the cap (3) of the coolant filler neck (2) on the radiator to relieve the excess pressure, then remove the cap (3).
- Place a container under the radiator drain plug (1) and unscrew it.
- Allow the cooling circuit to drain completely, checking that the orifices do not clog.
- Check the condition of the rubber hoses and fixing clamps, replace the rubber hoses if necessary.
- Rinse the circuit with clean water and use a cleaning product if necessary.
- Refit and tighten the radiator drain plug (1).

#### Refilling the coolant

- Slowly fill the circuit with coolant through the filler neck (2).
- Fill the cooling circuit level up to the center of the indicator (4) through the filler neck (2).

- Screw the radiator filler cap (3) back on.
- Run the engine at low speed for a few minutes.
- Check for any leaks.
- Check the level (4) and top up if necessary.



Figure 277: Coolant replacement

### 4.7.10 CABIN VENTILATION FILTERS REPLACEMENT

1. Stop the engine.
2. Remove the air intake (1) fixed on the cover behind the cabin to access the primary (2) and secondary (3) ventilation filter.
3. Remove the grille (4) that protects the filters (2 and 3) by unscrewing the knob (5).
4. Remove the primary filter (2) and secondary filter (3) by pulling them from the flap (3a) and replace them with new ones.
5. Reposition the secondary filter (3) and then the primary filter (2) in its seat.
6. Refit the grille (4) that protects the filters (2 and 3) locking it by screwing the knob (5).

- Refit and secure the air intake (1) on the cover behind the cabin.

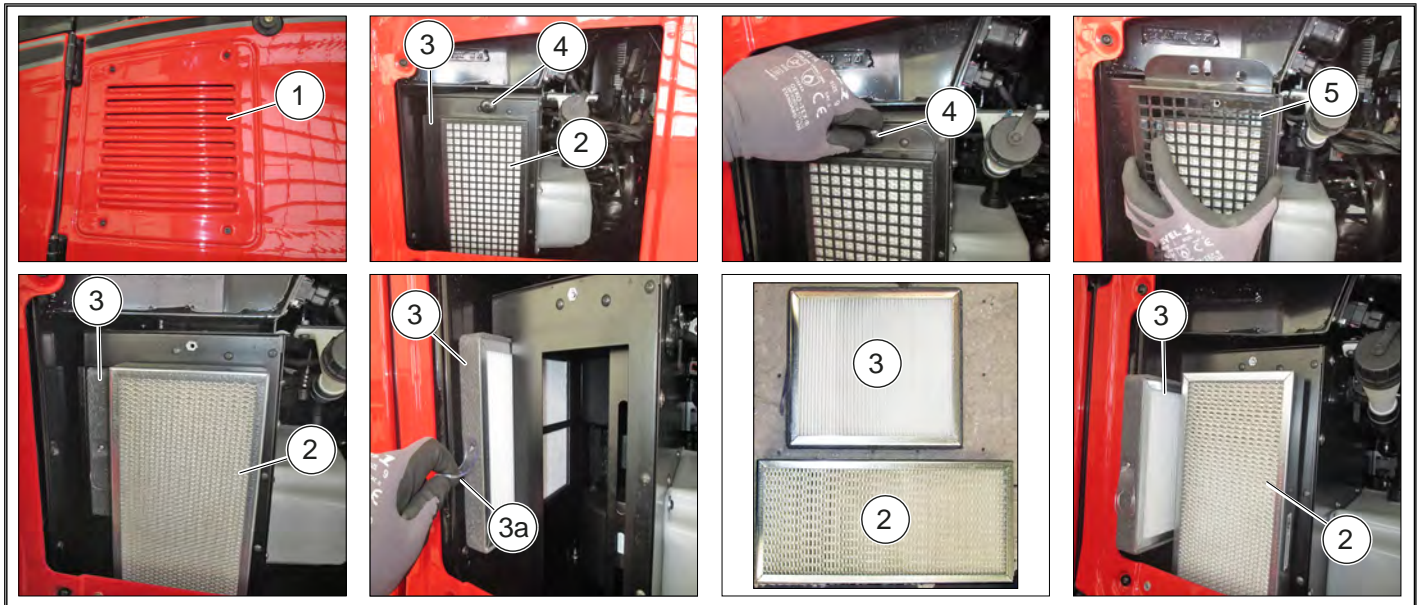


Figure 278: Cabin ventilation filters replacement

#### 4.7.11 WEAR OF THE EXTERNAL TELESCOPIC BOOM CHAINS CHECK

On chains, wear manifests itself in various places.

- On the joints, which results in a stretching of the chain.
- On the profile of the plates for contact with the pulleys.
- On the surfaces of the plates and the axes protruding by contact with the jaws of the pulleys.
- On the alignment of the shoulders of the protruding axes.

##### Lengthening of the chains

For this operation, we recommend the use of the chain control ruler.

- Place the telehandler on the stabilizers, with the boom horizontal.
- Fully extend the telescopic booms and insist on the command for a few moments to tighten the chains well.
- If the wear is not likely to be uniform along the entire length, divide the chain into 4 equal parts, and check the center of each part using the ruler.

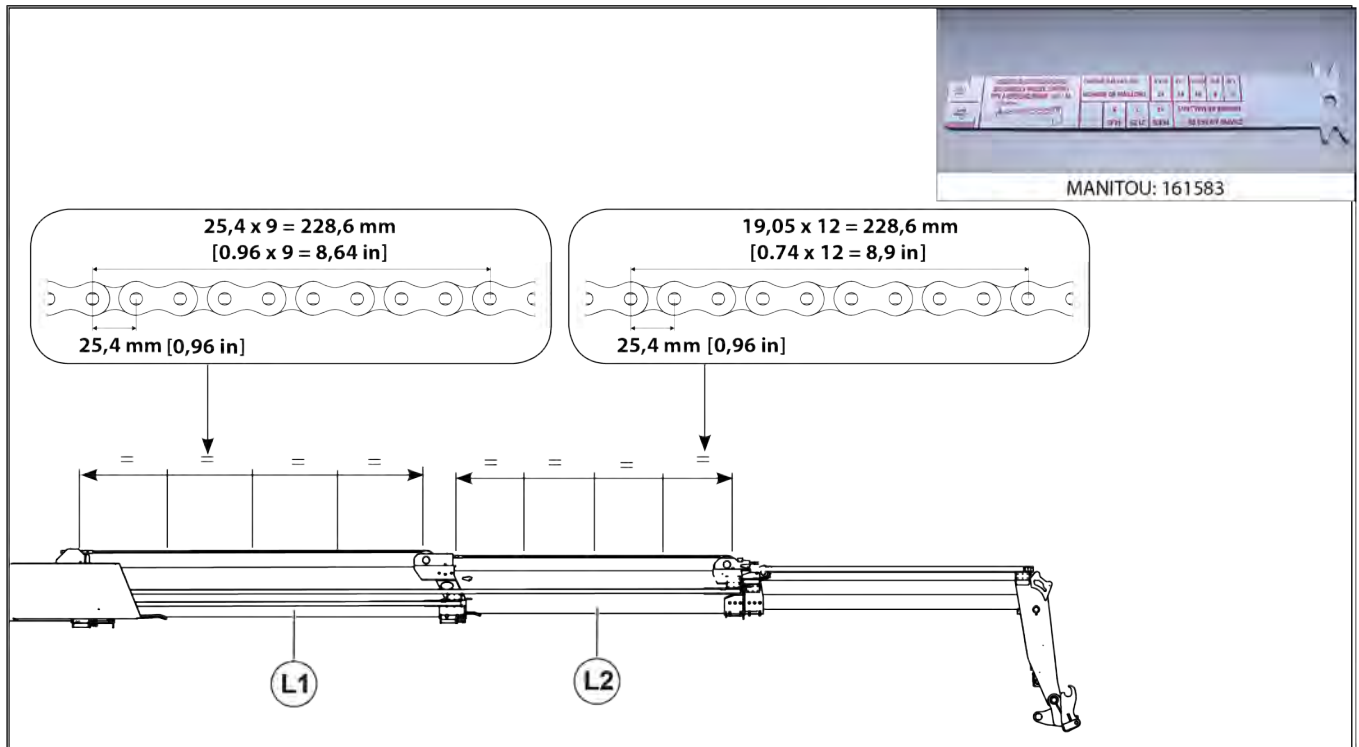


Figure 279: Wear of the external telescopic boom chains check

### ⚠ DANGER

Beyond the maximum value ( $228.6 \text{ mm} + 2\% = 233.2 \text{ mm}$ ) [ $8.6 \text{ in} + 2\% = 9.18 \text{ in}$ ], replace the pair of chains. Contact your dealer.

#### Wear of the profile of the plates

As for the lengthening of the chains, check the center of each equal part using a vernier gage.

### ⚠ DANGER

Beyond the maximum value ( $228.6 \text{ mm} + 2\% = 233.2 \text{ mm}$ ) [ $9 \text{ in} + 2\% = 9.18 \text{ in}$ ], replace the pair of chains. Contact your dealer.

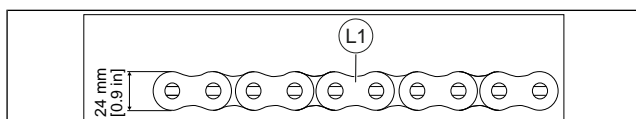


Figure 280: Wear of the profile of the plates 1

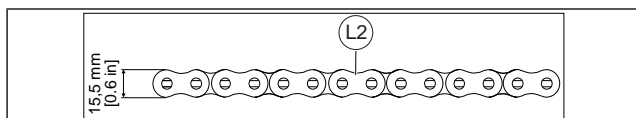


Figure 281: Wear of the profile of the plates 2

#### Wear of the protruding axles

As for the lengthening of the chains, check the center of each equal part using a vernier gage.

### ⚠ DANGER

Beyond the mini value ( $24 \text{ mm} - 2\% = 23.5 \text{ mm}$ ) [ $0.9 \text{ in} - 2\% = 0.88 \text{ in}$ ] and ( $15.5 \text{ mm} - 2\% = 15.2 \text{ mm}$ ) [ $0.6 \text{ in} - 2\% = 0.58 \text{ in}$ ], replace the pair of chains. Contact your dealer.

In addition to wear, the high pressures between the profile of the plates and the pulleys can cause an upset of material which causes a blockage of the joints; also in this case replace the pair of chains.

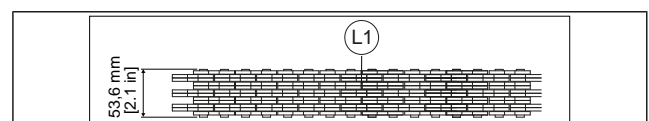


Figure 282: Wear of the protruding axles 1

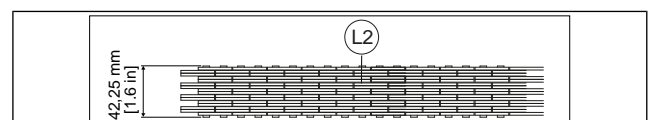


Figure 283: Wear of the protruding axles 2

#### Alignment of the shoulders of the protruding axes

Check the entire length of the chains. Strong friction between the plates and the protruding axes can cause the latter to rotate in the outer plates with consequent coming out of the seat.

If the shoulders are not aligned in the longitudinal direction of the chain, replace the pair of chains (See your dealer).

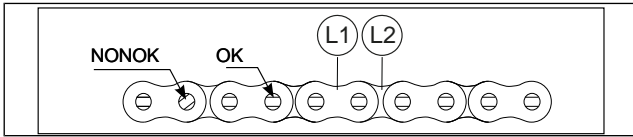


Figure 284: Alignment of the shoulders of the protruding axes

### 4.7.12 CHECK FOR WEAR AND INCREASE IN CLEARANCE OF THE FIFTH WHEEL BEARINGS

The clearance of the bearings with a new machine, measured in the factory, has an initial reference value of 0.05 ÷ 0.35 mm.

The maximum wear limit value of the bearing clearance is 2.3 mm and if a higher value is measured during a check, the washer must be replaced. As wear increases

intensify checks.

The test must be performed using a clock comparator with a centesimal scale, with the bearing stationary.

The oscillation between a condition with a negative moment and one with a positive moment will be detected.

Place the forklift on a flat surface, without load and with the boom raised to the maximum.

Then place the comparator between the turret and the chassis, as in the photo (1).

Check that everything is in order, lower the boom until it approaches the comparator and reset the clock. (negative condition).

Then raise the boom to the max and read the axial clearance value on the clock (positive condition).

The measured values compared with the maximum limit value provide the extent of wear.



Figure 285: Check for wear and increase in clearance of the fifth wheel bearings

### 4.7.13 REPLACE FILTER OF THE "DEF" BOOST PUMP

Place the telehandler on a level surface with the three-phase motor off.

**⚠ WARNING**

#### Risk of corrosive substances

The diesel emissions additive is a corrosive product. Protect the bodywork and wear personal protective equipment (gloves and goggles). Thoroughly clean the exterior of the pump to prevent dust from entering the system.

**⚠ WARNING**

#### High temperature risk

Before replacing the filter (4), make sure that all parts are sufficiently cooled. Be sure to replace the filter when the "DEF" additive level is low. Beware of "DEF" spillage when removing the filter cover.

#### Replace the filter element (4)

Place the telehandler on a level surface.

- Stop the three-phase motor and wait for the "DEF" boost pump (6) to stop.
- Remove the panel (5) under the "DEF" tank to access the "DEF" boost pump.
- Unscrew the pump cover (1), remove the compensator (2) and throw it away.

- Insert the extractor (3) (supplied with the new filter) into the filter element (4) until you hear a click.
- Pull the extractor to take out the filter element and then throw it away.
- Lightly lubricate the cover joint with suitable engine oil.
- Install the new filter element and compensator in the pump and screw the cover 1 (tightening torque: 20 +5 Nm - 2 +0.5 kgf-m).

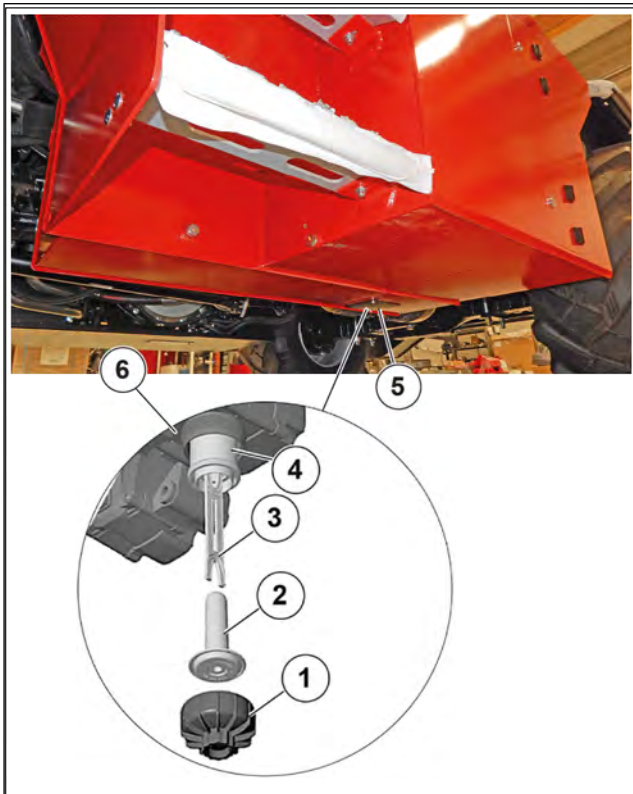


Figure 286: Replace filter of the "DEF" boost pump

#### 4.7.14 REPLACE THE "DEF" TANK BREATHER

Place the telehandler level and stabilized. Stop the three-phase motor.

- Remove the panel (1) above the tanks to access the "DEF" tank breather (2).
- Unscrew the breather (2) and replace it with a new one.
- Refit the panel (1) above the tanks.

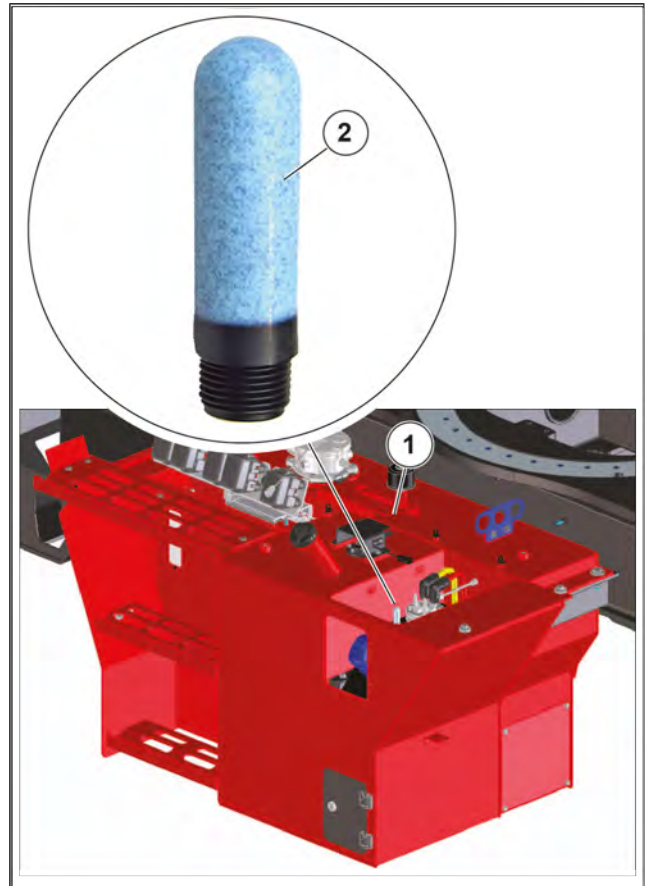


Figure 287: Replace the "DEF" tank breather

#### 4.7.15 SAFETY BELT CHECK

**⚠ DANGER**

Under no circumstances may the vehicle be used with a defective seat belt (fastening, locking, stitching, tearing, etc.). Repair or replace the seat belt immediately.

##### TWO-POINT SAFETY BELT

Check the following points:

- The fixing of the anchor points on the seat.
- Cleaning the belt and locking mechanism.
- The click of the locking mechanism.
- The state of the belt (tears, fraying).

##### AUTOMATIC SEAT BELT WITH TWO ANCHOR POINTS

Check the points listed above and the following:

- The correct running of the belt.
- The status of the reel masks.
- The locking of the reel mechanism by pulling the belt with a sharp jerk.

**⚠ DANGER**

Following an accident, replace the seat belt.

**SILENT BLOCK OF THE THREE-PHASE MOTOR CHECK**

Contact your dealer.

**CHECK AND ADJUSTMENT OF THE THREE-PHASE MOTOR AIR INTAKE SYSTEM**

Contact your dealer.

**THREE-PHASE MOTOR HOSES AND PIPES CHECK**

Contact your dealer.

**BRAKE CIRCUIT PRESSURE CHECK**

Contact your dealer.

**CHECK FOR WEAR OF THE TELESCOPIC BOOM SHOES****CONDITIONS OF THE HARNESSES AND CABLES CHECK****LIGHTING AND SIGNALING CHECK****SIGNALERS CHECK****CONDITIONS OF THE REAR VIEW MIRRORS CHECK**

Contact your dealer.

**CABIN STRUCTURE INTEGRITY CHECK**

Contact your dealer.

**CHASSIS STRUCTURE INTEGRITY CHECK**

Contact your dealer.

**4.7.17 REPLACING THE INTERNAL STABILIZER COMPONENTS**

Just for: MRT 2145, MRT 2545

For each stabilizer (1), replace:

- 1 eyebolt (2).
- 1 tie rod (3c) + wire rope (3b) + traction spring (3a).
- 1 magnet (3d) of the stabilizer boom.

**⚠ DANGER**

Any tampering not authorized by Manitou will void the warranty.

Contact your agent or dealer.

Do not attempt to replace or repair without the presence of a Manitou qualified person.



Figure 288: Replacing the internal stabilizer components

#### QUICK COUPLING OF ATTACHMENTS CHECK

Contact your dealer.

#### CONDITIONS OF THE ATTACHMENTS CHECK

Contact your dealer.

#### SERVICE AND PARKING BRAKE CHECK

Contact your dealer.

### 4.8. EVERY 2000 HOURS OF OPERATION OR EVERY 4 YEARS

#### 4.8.1 TIRE PRESSURE AND WHEEL NUT TIGHTENING CHECK

Check the condition of the tires for cuts, bumps, wear, etc.

Using a torque wrench, check the tightening torque of the wheel bolts.

Front wheels: 680 Nm  $\pm$  15%

Rear wheels: 680 Nm  $\pm$  15%

#### 4.8.2 HYDRAULIC OIL REPLACEMENT AND HYDRAULICS INTAKE FILTER CARTRIDGE CLEANING

Place the telehandler flat and stabilized.  
Fully retract and lower the telescopic boom.

Stop the three-phase motor.

**⚠ DANGER**

Before each intervention, thoroughly clean around the drain plugs and the suction nozzle of the hydraulic tank. Use a very clean bowl and funnel. Also clean the top of the oil can before filling. Dispose of waste oil in an environmentally friendly manner.

- Remove the panel (1) to access the oil filler cap (2). Remove the cap (2) to facilitate draining.
- Place a suitable container under the drain plug (3) and unscrew it.
- Remove the drain plug (3) to drain the hydraulic oil from the tank.
- Refit and tighten the drain plug (3).

**Oil drain**

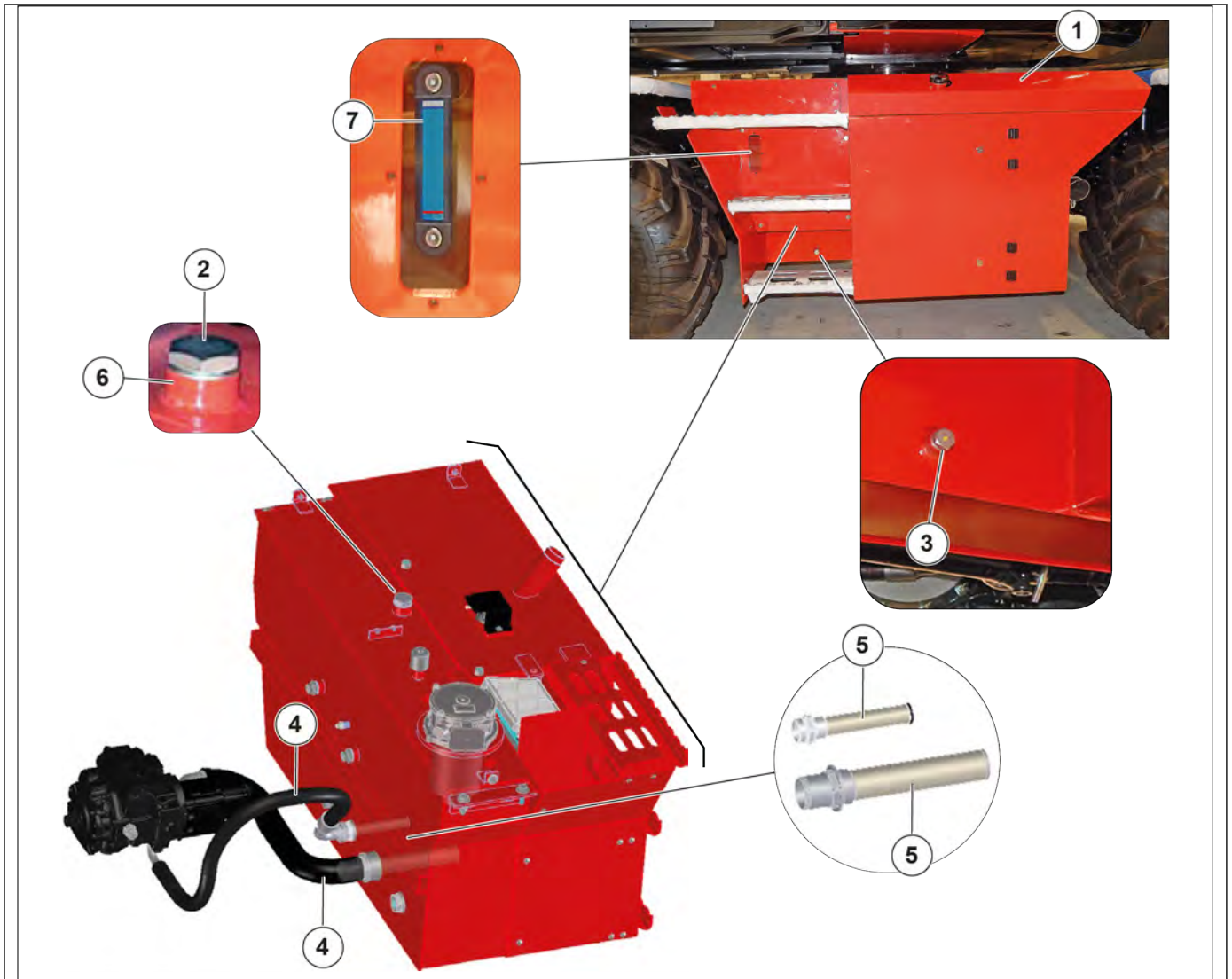


Figure 289: Hydraulic oil replacement and hydraulics intake filter cartridge cleaning

**Cleaning the strainer**

- Disconnect the hose (4).
- Unscrew the suction strainer (5), clean it with a jet of compressed air, check its condition and replace it if necessary.
- Reassemble the suction strainer checking that the gasket is correctly positioned.

**Filling with oil**

Fill the tank with new oil through the filler neck (6) until the oil level is equidistant between the lower and upper reference marks of the level indicator (7).

Check for leaks from the drain hole (3).

Refit the oil tank filler cap (2).

**De-pollution of the hydraulic circuit**

Let the three-phase motor run (accelerator pedal halfway) for 5 minutes without any load on the forklift;

afterwards, for another 5 minutes using all the hydraulic movements (except the direction and service brakes).

Bring the three-phase motor to maximum speed for 1 minute; then apply the direction and service brakes.

This operation allows the circuit to be cleaned by means of the hydraulic oil filter on the intake.

### RADIATOR CHECK

Contact your dealer.

### TRANSMISSION PRESSURES CHECK

Contact your dealer.

### STEERING CHECK

Contact your dealer.

### CONDITION OF THE BOOM ASSEMBLY CHECK

Contact your dealer.

### ARTICULATION BEARINGS AND RINGS CHECK

Contact your dealer.

### CONDITIONS OF HOSES AND PIPES CHECK

Contact your dealer.

### CONDITIONS OF THE CYLINDERS (LEAK, RODS)

Contact your dealer.

### HYDRAULIC CIRCUIT PRESSURES CHECK

Contact your dealer.

### ARTICULATION BEARINGS AND RINGS CHECK

Contact your dealer.

### AIR CONDITIONING (OPTIONAL)

Contact your dealer.

### CLEANING OF THE COILS OF THE CONDENSER AND EVAPORATOR

### CLEANING OF THE CONDENSATE CONTAINER AND THE DISCHARGE VALVE

### RECOVERY OF THE COOLANT TO REPLACE THE DRYER FILTER

### FILLING WITH COOLANT AND CHECKING THE THERMOSTATIC REGULATION AND PRESSURE SWITCHES



*When opening the evaporator unit, do not forget to replace the lid seal.*

### ⚠ WARNING

#### Risk of corrosive materials

NEVER ATTEMPT TO REPAIR ANY ANOMALIES BY YOURSELF. TO CHARGE A CIRCUIT ALWAYS CONTACT THE DEALER WHO HAS THE SUITABLE SPARE PARTS, THE TECHNICAL NOTIONS AND THE NECESSARY TOOLS. In the following cases, contact a doctor. If inhaled, take the person to an open environment. In case of skin contact, rinse immediately with plenty of running water. In case of frostbite, apply a sterile dressing. In case of contact with eyes, rinse with fresh water for about 15 minutes.

#### IMPORTANT INFORMATION CONCERNING THE COOLANT USED


- This product contains fluorinated greenhouse gases relevant under the Kyoto protocol.
- Type of coolant: R134A; colorless and odorless and heavier than air. It has a PRG (Global Warming Potential) value of 1430.
- Never let the gas escape into the atmosphere. Never open the circuit as this would cause a loss of coolant.
- The compressor is equipped with an oil level indicator. Never unscrew this indicator: this will drain the circuit. The oil level should only be checked when changing the oil.

### 4.8.4 REPLACEMENT OF THE THREE-PHASE MOTOR SERVICE BELT

- Open the engine cover.
- Remove the protective casing (1).

## BELT REMOVAL

- Insert the 1/2" socket wrench in the square rod of the automatic tensioner (2).
- Turn the socket wrench counter-clockwise and block the tensioner with a tool (3) (pin punch) to loosen the belt and extract it.
- Extract the belt from the alternator 4.

 *Take advantage of the belt removal to check the correct functioning of the pulleys and bearings (noise, friction, clearance, etc.).*

## BELT REPOSITIONING

- Reposition the new belt onto the alternator.
- Make sure it is positioned correctly in the grooves of each pulley.
- Maintain the force applied to the socket wrench, extract the tool (3) (pin punch) and release the force applied to the socket wrench.
- Check the correct positioning of the belt (4).
- Refit the protective casing (1).

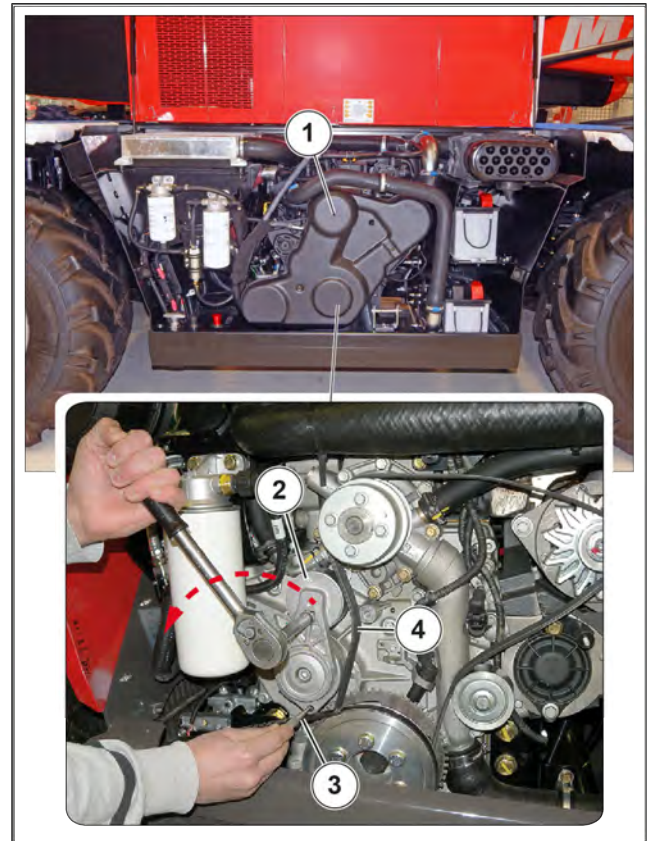


Figure 290: Replacement of the three-phase motor service belt

## 4.9. EVERY 3000 HOURS OF OPERATION OR EVERY 6 YEARS

### 4.9.1 AIR FILTER SAFETY CARTRIDGE REPLACEMENT

- Remove/refit the dry air filter cartridge to locate the safety filter of the air filter.
- Carefully pull out the dry air filter safety cartridge (1) to minimize dust escaping.
- Carefully clean the seat of the filter seals with a damp, clean, lint-free cloth.
- Before refitting, check the condition of the new safety cartridge.
- 


 *The frequency of replacement of the safety cartridge is given for information only. It must be replaced after every three dry air filter cartridge replacements.*

Figure 291: Air filter safety cartridge replacement

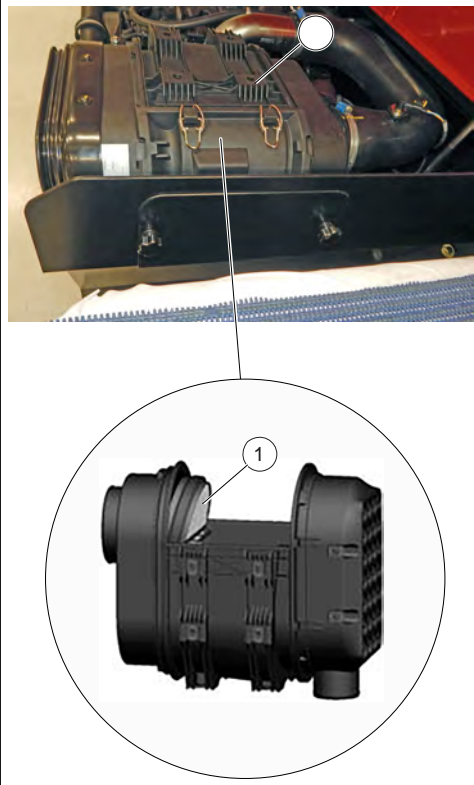
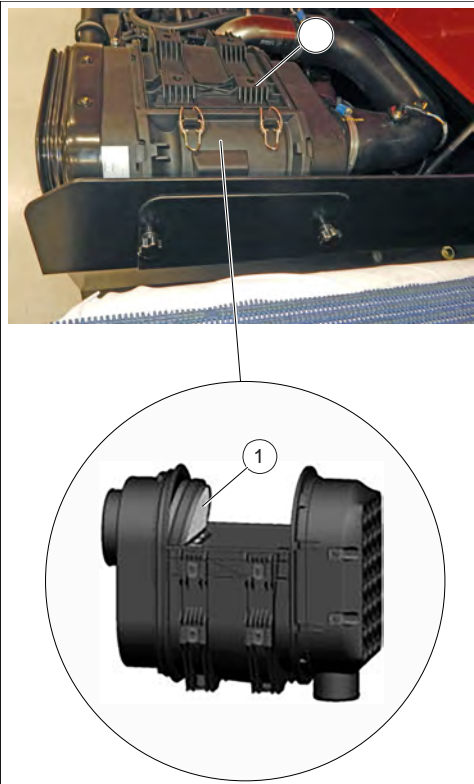



Figure 2: Air filter safety cartridge replacement



## 4.10. OCCASIONAL MAINTENANCE

### 4.10.1 INSERTING THE SAFETY WEDGE OF THE TELESCOPIC BOOM

 Only use the safety wedge (1) supplied with the telehandler.

**⚠ DANGER**

#### Risk of crushing

During installation of the safety wedge, do not stand under the telescopic boom.

The telescopic handler is equipped with a safety wedge (1) which prevents accidental descent of the telescopic boom during maintenance operations of the same or in the areas below it. The boom safety wedge must be installed on the rod of the handler cylinder.

When not in use, the safety wedge (1) is positioned on the telehandler turret through its fixings (1a).

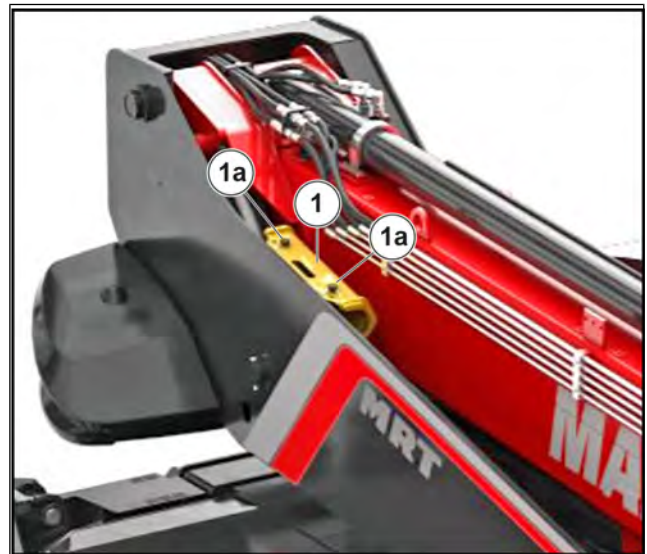


Figure 292: Boom safety wedge

#### REFITTING THE WEDGE

1. Raise the boom to the maximum.
2. Place the safety wedge 1 on the rod of the lifting cylinder and lock with the shaft 2 and the split pin 3.

3. Lower the boom slowly then stop the hydraulic movements before hitting the wedge.

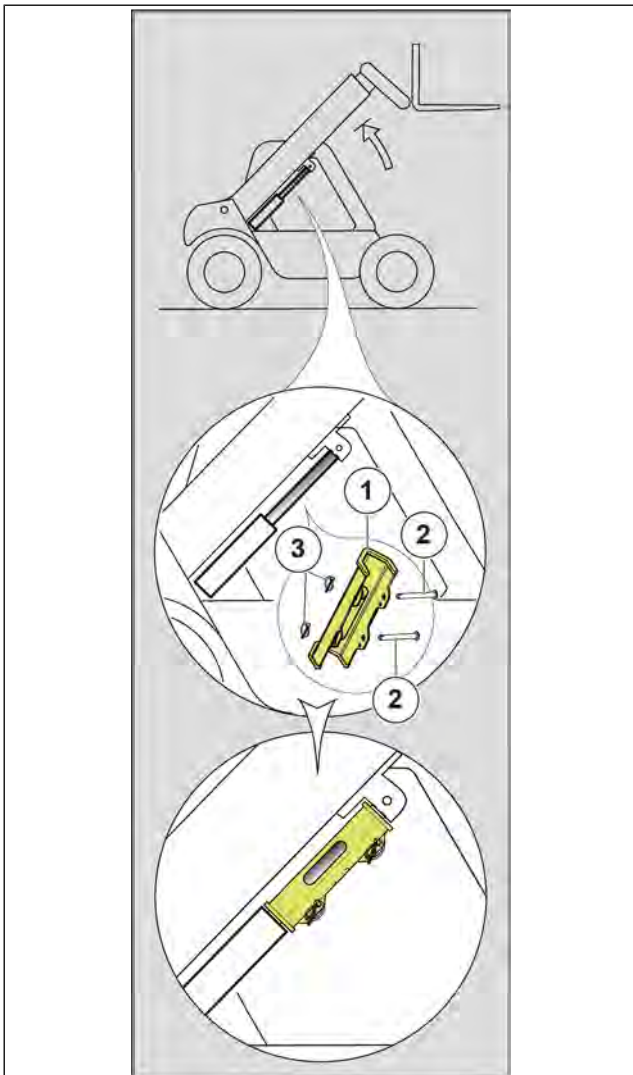


Figure 293: Inserting the safety wedge of the telescopic boom

#### DISASSEMBLY OF THE WEDGE

- a. Raise the boom to the maximum.
- b. Remove the split pin and the shaft.
- c. Put the safety wedge back into the compartment on the telehandler.

### 4.10.2 WHEEL REPLACEMENT

The replacement procedure is necessary if the tire is punctured or damaged.

1. Stop the vehicle on flat level compact ground in the transport position (boom completely low and retracted).
2. Activate the parking brake.
- 3.

## ⚠ DANGER

#### Accident

If the wheel must be changed on a public road or one that is accessible to other vehicles

Position the vehicle warning signal (for example, emergency triangle) in accordance with the road circulation laws and regulations in force in the country.

Turn on the hazard lights.

4. Turn off the engine.
5. Put wheel stop wedges under the tires to prevent any unnecessary and accidental movement of the vehicle. Place the wedges so that the vehicle is immobilized in both directions on the axle opposite the wheel to be changed.
6. On the wheel that you are changing, loosen the lug nuts with a wrench or screwdriver, and unscrew the lug nuts counterclockwise.



*The wrench or screwdriver will only loosen the bolt, not remove it completely. The operation can be completed simply with your fingers.*

7. Use the following to lift the vehicle:
  - the vehicle stabilizers;
  - a lifting device with a capacity greater than half the weight of the vehicle. For example, if the vehicle weighs 20000 kg (44092 lbs), the lifting device capacity > 10000 kg (22046 lbs).

#### Using a lifting device to change the wheel

- a. Place the lifting device under the axle housing, as close to the wheel as possible and adjust it (1).

## ⚠ DANGER

**Do not place your feet or other body parts under any vehicle on a lift because it might move and fall.**



Figure 294: Use of a lifting device and a safety support (example)

- b. Lift the vehicle with the lifting device until the tire is approximately 100 mm (4 in) off the ground. This will facilitate the removal of the wheel with the damaged tire and then allow you to fit the wheel with the new tire.
- c. Place a safety support (2) under the axle.
- d. Completely remove the lug nuts.
- e. Remove the wheel from the axle and place it under or on the side of the vehicle.
- f. Fit a new wheel onto the axle hub.
- g. Manually tighten the lug nuts.
- h. Tighten the wheel bolts securely with a torque wrench [4.4.2 TIRE PRESSURE AND WHEEL NUT TIGHTENING CHECK](#), page 271.

When fastening the lug nuts, it is important to work in the criss-cross pattern as shown below.

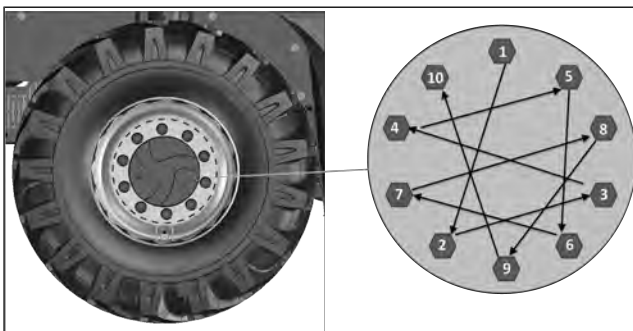


Figure 295: Criss-cross Tightening Sequence

- i. Once the lug nuts have been tightened, remove the safety support (2) and lower the vehicle with the lifting device (1).

### Use of stabilizers when changing a tire

- a. operate the 4 stabilizers of the vehicle to lift it until the tires are about 100 mm (4 in) from the ground .

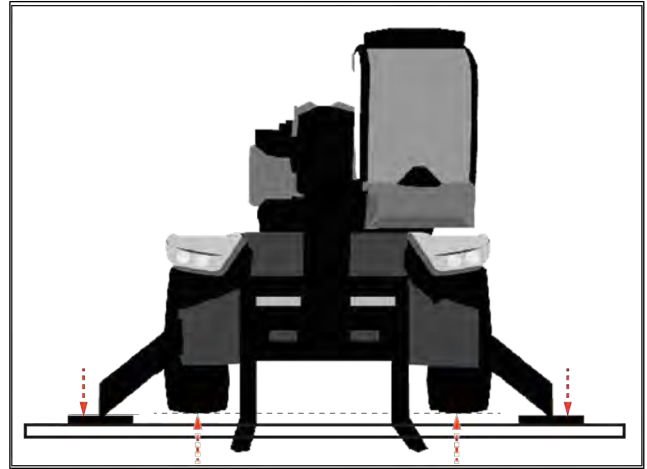


Figure 296: Use of stabilizers when changing a tire

- b. Completely remove the lug nuts.
- c. Remove the wheel from the axle and place it under or on the side of the vehicle.
- d. Fit a new wheel onto the axle hub.
- e. Manually tighten the lug nuts.
- f. Tighten the wheel bolts securely with a torque wrench [4.4.2 TIRE PRESSURE AND WHEEL NUT TIGHTENING CHECK](#), page 271.

When fastening the lug nuts, it is important to work in the criss-cross pattern as shown below.

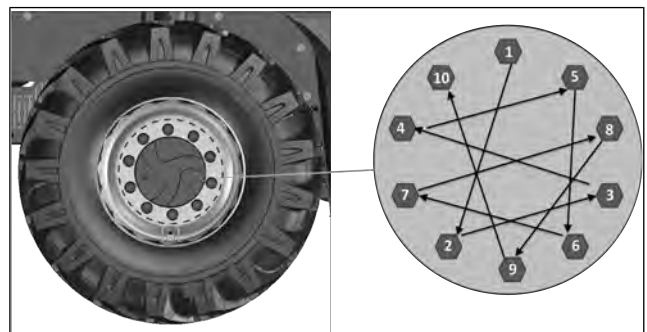


Figure 297: Criss-cross Tightening Sequence

- g. Once the lug nuts have been tightened, use the 4 stabilizers to lower the vehicle until its tires rest on the ground .

### 4.10.3 HEADLIGHTS ADJUSTMENT

*Adjustment recommendations (According to ECE-76/756 76/761 ECE20 standards).*  
Adjustment of -2% of the dipped beam headlights with respect to the horizontal axis of the headlight.

Adjustment procedure

1. Place the forklift, empty, in transport position, perpendicular to a white wall, on flat and horizontal ground.
2. Check the tire pressure.

3. Select the direction reverser in idleoff and apply the parking brake.

Calculation of the height of the dipped beam headlights (h2)

h1 = Height above the ground of the dipped beam headlights.  
h2 = Height of the adjusted beam.  
l = Distance between the dipped beam headlights and the white wall.  
 $h2 = h1 - (l \times 2/100)$ .

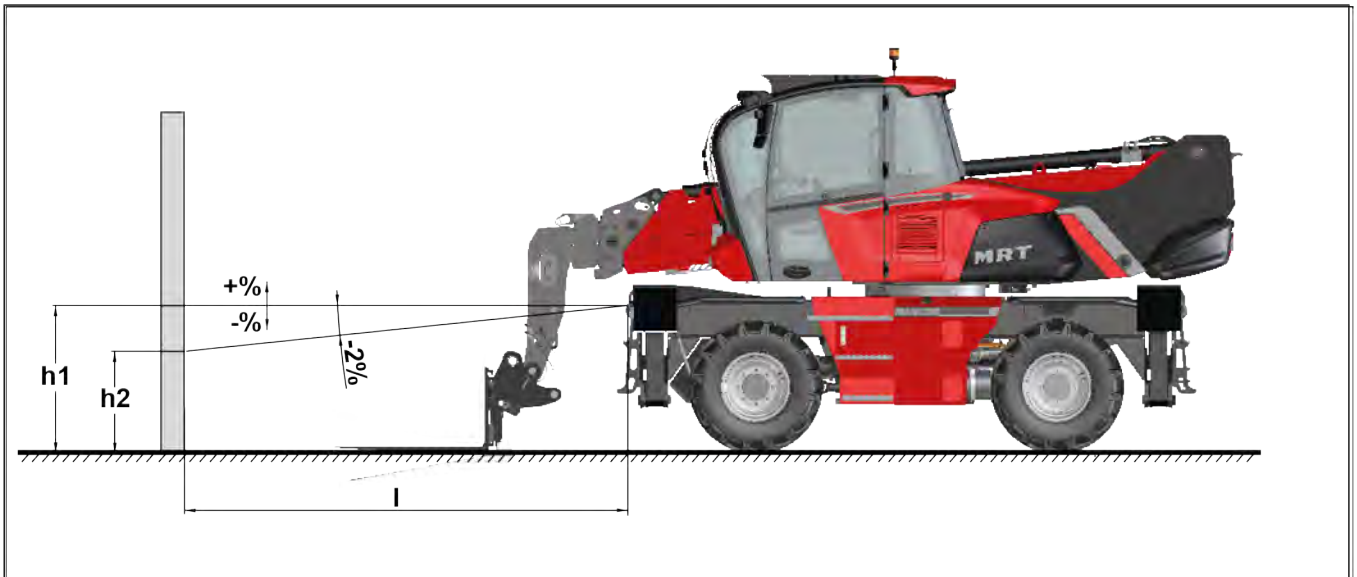


Figure 298: Headlights adjustment

### 4.10.4 REPLACING THE FUSES AND RELAYS

#### FUSE AND RELAY IN CAB

Remove the panel (1) behind the driver seat for access to the fuse box and relays (2).

**⚠ DANGER**

Always replace a faulty fuse with another of equivalent rating. Never use a fuse that has been.



Figure 299: Fuse and relay in cab

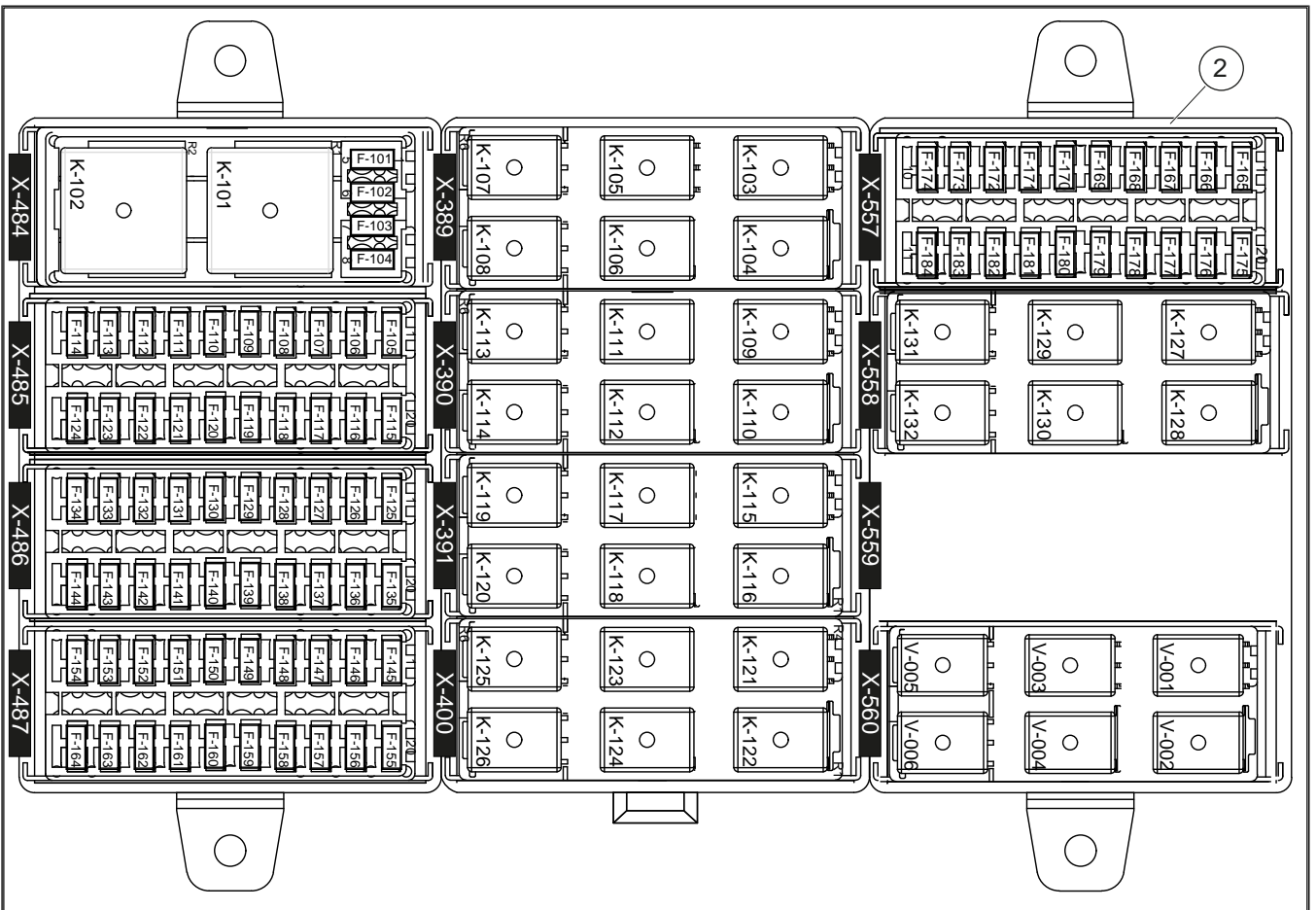





Figure 300: Overview of fuse and relays

Table 201. Specification table of the fuses and relays in cab

		Functions
<b>X-484</b>		
K-101	-	Flasher unit
K-102	20/30 A	Cab ventilation system supply
F-101	10 A	" +15" Attachment solenoid (12V)
F-102	5 A	" +15" DSB Switch (12V)
F-103	7.5 A	" +15" Car radio (12V)
F-104	5 A	" +15" 12V plugs (12V)
<b>X-485</b>		
F-105	15 A	" +30" Bucket Mix
F-106	5 A	" +30" VBATP Master SPU
F-107	5 A	" +30" Stand-By Display
F-108	5 A	" +30" Roof light
F-109	5 A	" +30" OBDII Diagnostic plug
F-110	-	Available
F-111	2 A	" +30" Anti Theft
F-112	3 A	" +30" Pred. supply connector
F-113	2 A	" +30" DC-DC Converter
F-114	15 A	" +30" A / C fan roof 1
F-115	15 A	" +30" A / C fan roof 2
F-116	-	Available
F-117	-	Available
F-118	-	Available
F-119	-	Available
F-120	-	Available
F-121	-	Available
F-122	-	Available
F-123	-	Available
F-124	20 A	" +30" Cab ventilation relay
<b>X-486</b>		
F-125	-	Available
F-126	3 A	" +15" Predisposition supply
F-127	5 A	" +15" Foot throttle supply
F-128	5 A	" +15" Safety / Stop remote control
F-129	5 A	" +15" Light lever
F-130	2 A	" +15" Easy manager
F-131	-	Available
F-132	10 A	" +15" VP Midac Plus
F-133	5 A	" +15" Beacon
F-134	15 A	" +15" Seat power supply
F-135	15 A	" +15" Seat inclination management
F-136	-	Available
F-137	5 A	" +15" Ventilation fan relay
F-138	5 A	" +15" Door microswitch

		<i>Functions</i>
F-139	5 A	"+15" A / C - Heater control panel
F-140	5 A	"+15" A / C compressor Clutch
F-141	-	Available
F-142	5 A	"+15" Video camera
F-143	5 A	"+15" Proxy tower alignment
F-144	20 A	"+15" Solenoid supply
<b>X-487</b>		
F-145	10 A	"+15" Rear window heater
<b>X-389</b>		
K-103	15 A	Front wiper 1st speed
K-104	15 A	Front wiper 2nd speed
K-105	15 A	Roof wiper
K-106	15 A	Rear wiper
K-107	15 A	Lateral wiper
K-108	15 A	Beacon light
<b>X-390</b>		
K-109	15 A	Electric mirror heater
K-110	15 A	Floor mat heater
K-111	15 A	Rear window heater
K-112	15 A	Available
K-113	15 A	"+15" From key
K-114	15 A	Corner light
<b>X-391</b>		
K-115	15 A	Direction light LH
K-116	15 A	Direction light RH
K-117	15 A	Easy link no keypad (OPT)
K-118	15 A	Easy link with keypad (OPT)
K-119	15 A	Cabin ventilation
K-120	-	Available
<b>X-400</b>		
K-121	15 A	Unlocking 3D basket
K-122	15 A	Rotation 3D basket
K-123	15 A	Lifting 3D basket
K-124	15 A	Tilting 3D basket
K-125	15 A	12V Out Boom head
K-126	15 A	Available
<b>X-557</b>		
F-165	7.5 A	"+15" Front cab working light
F-166	7.5 A	"+15" Rear cab working light
F-167	10 A	"+15" Boom working light
F-168	-	Available
F-169	-	Available
F-170		Available

		<i>Functions</i>
F-171	-	Available
F-172	-	Available
F-173	5 A	"+15" Spot and ladder light
F-174	-	Available
F-175	15 A	"+15" Basket supply
F-176	5 A	"+15" Joystick
F-177	5 A	"+15" Navi Encoder
F-178	5 A	"+15" OBD Diagnostic plug
F-179	10 A	"+15" Boom pressure sensor
F-180	5 A	"+15" Slip Ring encoder
F-181	5 A	"+15" Safety switch
F-182	5 A	"+15" Red button
F-183	5 A	"+15" Remote switch
F-184	15 A	"+15" DC-DC Converter
<b>X-558</b>		
K-127	15 A	A / C Fan Roof 1
K-128	15 A	A / C Fan Roof 2
K-129	15 A	A / C Compressor clutch
K-130	15 A	Front cab working light
K-131	15 A	Rear cab working light
K-132	15 A	Boom working light
<b>X-559</b>		
-	-	Not used
<b>X-560</b>		
V-001	3 A	Diode module
V-002	3 A	Diode module
V-003	3 A	Diode module

### FUSE AND RELAY ON THE CHASSIS

Remove the panel (1) behind the step under the cab for access to the fuse box and relays (2a - 2b).  
Remove the cap to access the fuse and relays.



Always replace a faulty fuse with another of equivalent rating. Never use a fuse that has been.

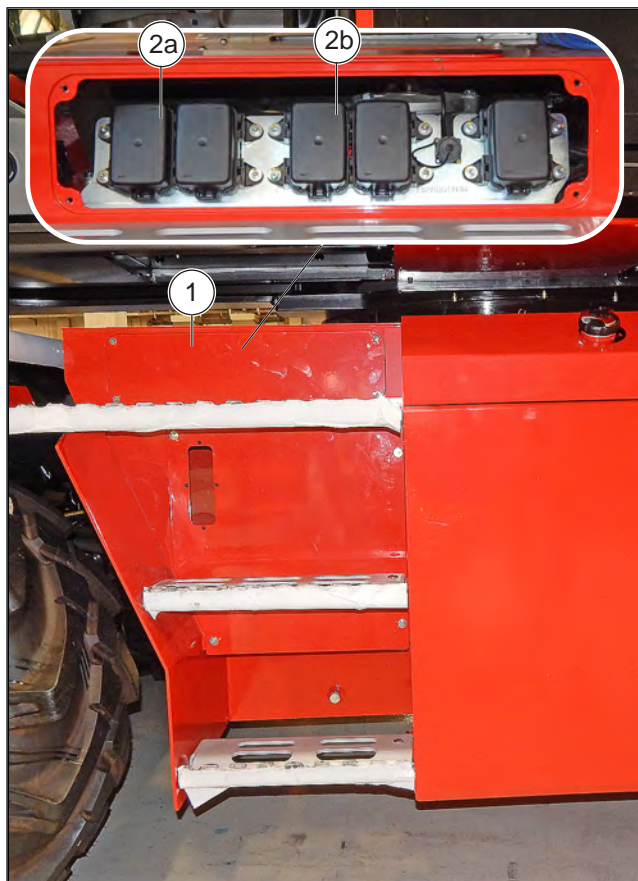


Figure 301: Fuse and relay on the chassis

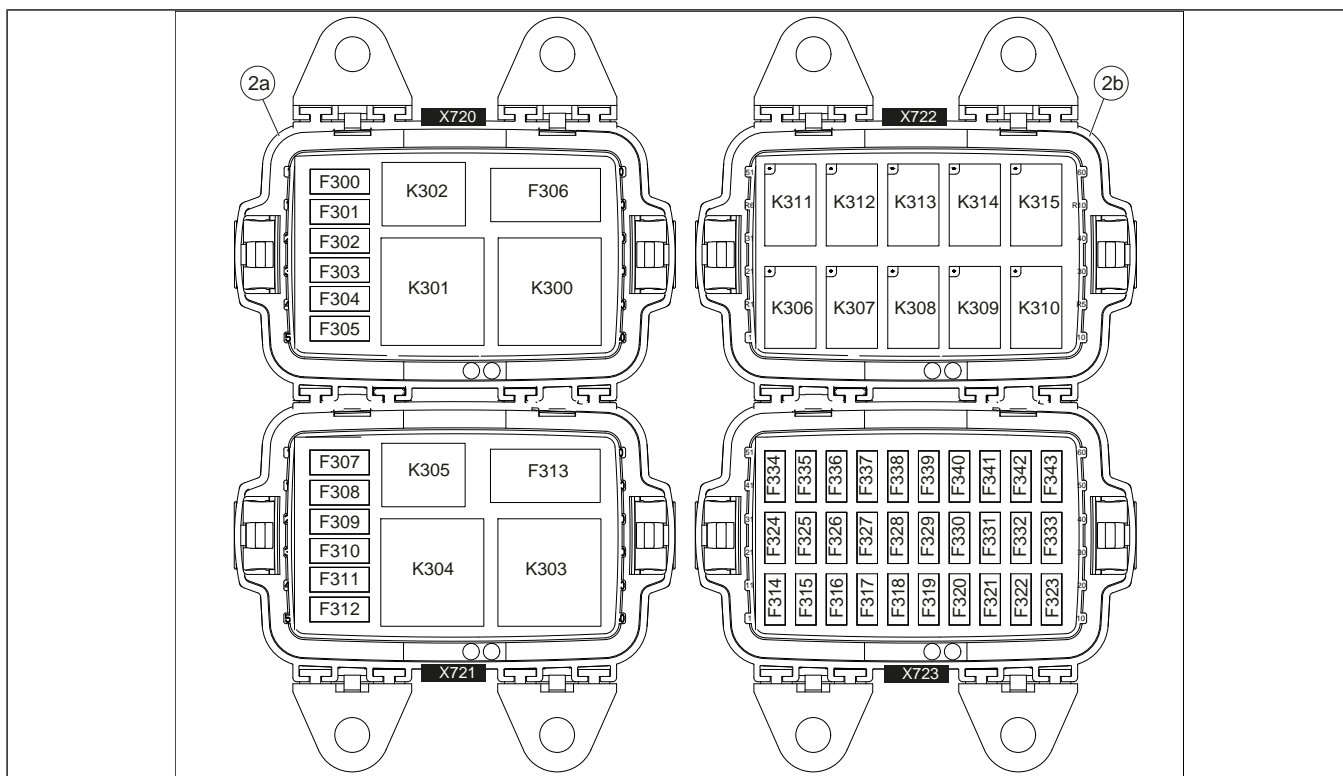




Figure 302: Overview of fuse and relays:

Table 202. Specification table of the fuses and relays on chassis

		Functions
<b>X-720</b>		
F-300	5 A	Electric emergency pump
F-301	-	Available
F-302	10 A	"15" VBATD Auxiliary SPU
F-303	10 A	"15" VBATE Auxiliary SPU
F-304	5 A	"15" Front / rear axle alignment sens.
F-305	5 A	"15" Stabilizer fully up sensor
F-306	30 A	Engine fuse box supply
K-300	50 A	Hydraulic oil cooler electric fan
K-301	-	Available
K-302	15 A	Electric emergency pump
<b>X-721</b>		
F-307	5 A	"30" VBATP Auxiliary SPU
F-308	10 A	"30" VBATC Auxiliary SPU
F-309	15 A	"30" Cab ventilation supply
F-310	10 A	"30" Water heater supply
F-311	10 A	"30" Unswitched supply
F-312	10 A	"30" Pneutron / Heater
F-313	20 A	"30" Gasoil Heater
K-303	50 A	Vehicle power ECU
K-304	50 A	Gasoil Heater
K-305	15 A	"15" ECU / Sensors
<b>X-722</b>		
K-306	20 A	Road light relay
K-307	20 A	High beam relay
K-308	20 A	Low beam relay
K-309	20 A	Stop light relay
K-310	20 A	Reverse light relay
K-311	20 A	Fog light relay
K-312	20 A	Neutral gear relay
K-313	20 A	Fuel feed relay
K-314	-	Available
K-315	-	Available
<b>X-723</b>		
F-314	10 A	"15" VBATD1 Vehicle SPU
F-315	10 A	"15" VBATD2 Vehicle SPU
F-316	10 A	"15" VBATD3 Vehicle SPU
F-317	10 A	"15" VBATD4 Vehicle SPU
F-318	10 A	"15" VBATD5 Vehicle SPU
F-319	10 A	"15" VBATD6 Vehicle SPU
F-320	10 A	"15" VBATD7 Vehicle SPU
F-321	10 A	"15" VBATF1 Vehicle SPU
F-322	10 A	"15" VBATF2 Vehicle SPU

		<i>Functions</i>
F-323	10 A	"15" VBATF3 Vehicle SPU
F-324	10 A	"15" VBATF4 Vehicle SPU
F-325	5 A	"15" Bi-Energy system
F-326	5 A	"15" Parking brake sensors
F-327	7.5 A	"15" Clapet
F-328	5 A	"15" Chassis level sensor
F-329	5 A	Gear microswitch
F-330	5 A	"15" Stabilizer low position sensor
F-331	5 A	"15" Stabilizer on ground sensor
F-332	5 A	Fog Light
F-333	15 A	Fuel feed pump
F-334	5 A	Road Light
F-335	5 A	Road Light
F-336	7.5 A	High beam
F-337	7.5 A	Low beam
F-338	5 A	Stop light
F-339	5 A	Reverse light
F-340	5 A	"30" VBATP Slave SPU
F-341	-	Available
F-342	7.5 A	"30" Clapet
F-343	10 A	"30" Main key

## POWER BOX (PDU) FUSE OF THE ENGINE COMPARTMENT

Open the hood (1) to access the fuse box (2).  
Remove the cover to access the fuse.

**⚠ DANGER**

Always replace a faulty fuse with another of equivalent rating. Never use a fuse that has been.

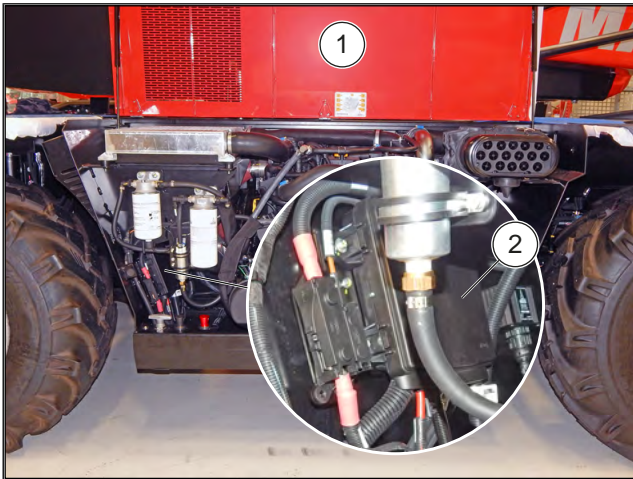


Figure 303: Power box (PDU) fuse of the engine compartment

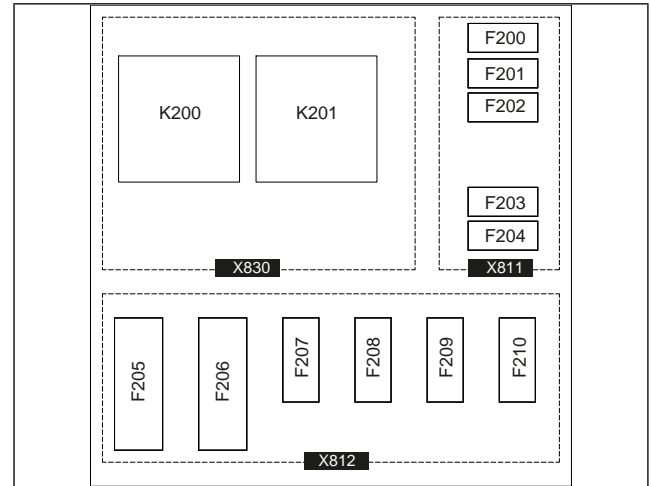



Figure 304: Overview of fuse:

Table 203. Specification table of the power box (PDU) fuse of the engine compartment

		<b>Functions</b>	
<b>X-811</b>			
F-200	15 A	NOx Sensor supply	
F-201	5 A	DEF Heated sensor	
F-202	5 A	Alternator & diagnostic plug	
F-203	5 A	DC-DC converter for throttle valve	
F-204	5 A	Glow plug feedback	
<b>X-812</b>			
F-205	100 A	Chassis power supply	
F-206	100 A	Tower power supply	
F-207	30 A	Air cooler fan	
F-208	30 A	DEF Heating system	
F-209	30 A	Engine ECU power supply	
F-210	60 A	Glow plug supply	
<b>X-830</b>			
X-200	80 A	Air cooler electric Fan	
X-201	80 A	Glow plug relay	

### RELAYS BOX ENGINE

Remove the panel (1) behind the step under the cab for access to the relays box (2).

Remove the cap to access the relays.

**⚠ DANGER**

Always replace a faulty fuse with another of equivalent rating. Never use a fuse that has been.

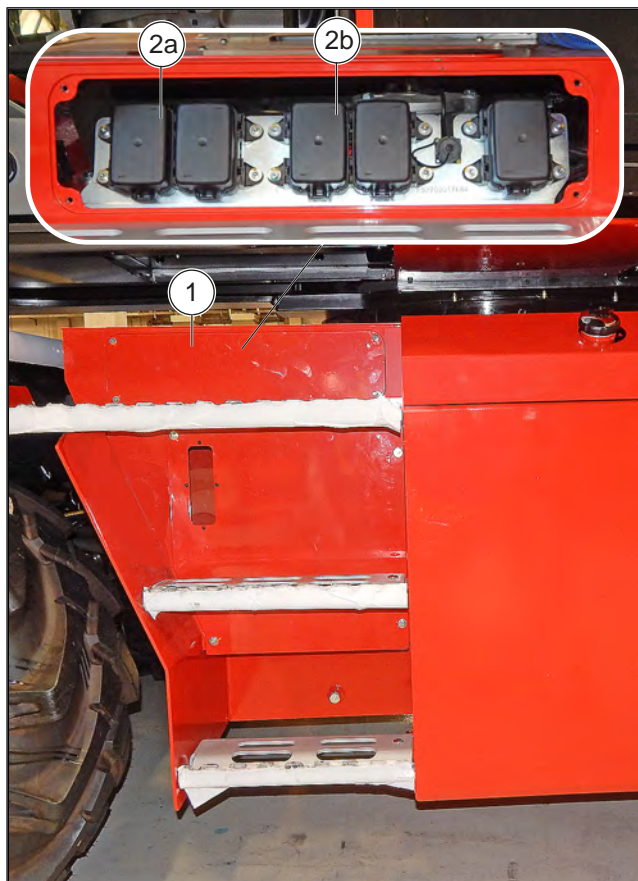


Figure 305: Relays box engine

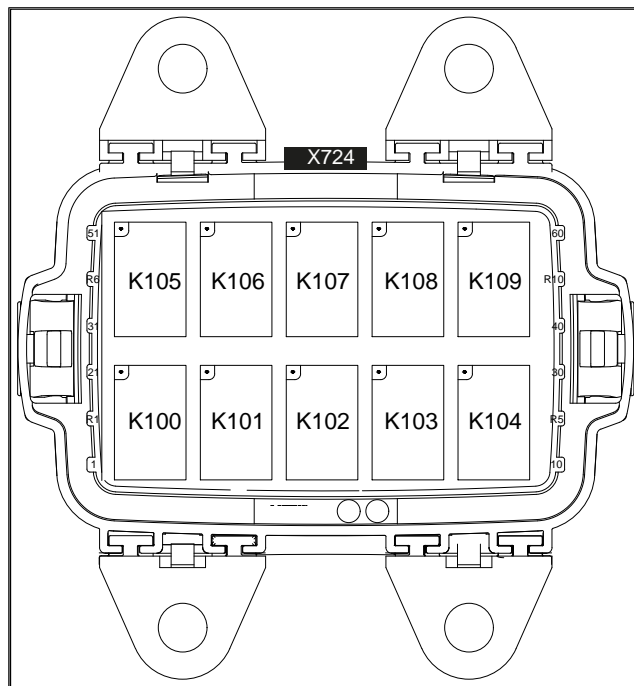



Figure 306: Overview of relays:

Table 204. Specification table of the relays engine ST.V / T4

		<b>Functions</b>
<b>X-724</b>		
K-400	20 A	DEF Heating supply relay
K-401	20 A	Supply module heating relay
K-402	20 A	DEF heating pipe relay
K-403	20 A	DEF heating pipe relay
K-404	20 A	DEF heating pipe relay
K-405	-	Available
K-406	-	Available
K-407	-	Available
K-408	-	Available
K-409	-	Available

### 4.10.5 CHECK AND CLEANING OF THE TRANSMITTER RINGS OF THE ROTATING ELECTRIC COLLECTOR (AFTER 3 MONTHS OF INACTIVITY)

Only for machine MRT 360

**⚠ DANGER**

Raise the boom and place the safety wedge on the rod of the lifting cylinder.

\* Contact your agent or dealer.



Figure 307: Check and cleaning of the transmitter rings of the rotating electric collector

### 4.10.6 REMOTE CONTROL CHECK

#### Routine daily maintenance

Before starting work:

- Make sure that the housing and battery contacts are always clean.
- Check that the gaskets, bellows and caps of the actuators (joysticks, selectors and buttons) are intact, soft and elastic.
- Check that the symbols on the transmitter unit panel are clearly visible and replace the panel if necessary.
- Check the legibility and integrity of the three nameplates on the transmitter unit.
- Check the correct mechanical operation of the STOP button.

During normal operation:

- Check that the transmitter unit is structurally intact.
- Make sure that no materials (e. g. cement, sand, lime, dust) are deposited on the transmitter unit that could compromise its use and safety.

After using the remote control:

- Clean the transmitter unit: never use solvents or flammable/corrosive products and do not use high pressure cleaners or steam cleaners.
- Store the transmitter unit in a clean and dry environment.

#### Routine quarterly maintenance

Every 3 months:

- Remove dust or other buildup of material from the receiving unit.

- To clean, never use solvents or flammable/ corrosive products and do not use high pressure cleaners or steam cleaners.
- Check that the receiving unit is structurally intact.
- Check the integrity and connection of the receiving unit wiring.
- Check that the symbols on the receiving unit panel are clearly visible and replace the panel if necessary.
- Check the readability and integrity of the plates of the receiving unit.

#### Extraordinary maintenance

**⚠ DANGER**

Any faults can only be repaired by authorized personnel. (contact the MANITOU assistance service).

#### Troubleshooting Guide

When the remote control does not work, it is necessary:

- to move the transmitting unit closer to the receiving unit in order to avoid noise and radio interference.
- to check if the problem affects the remote control or the machine. Therefore, before carrying out any checks, try to control the machine through a control station other than the remote control, if present.

If it persists, the problem affects the machine itself. Otherwise the problem concerns the remote control. In this case, refer to the paragraph "Malfunctions reported by the transmitter unit".

### MALFUNCTIONS REPORTED BY THE TRANSMITTER UNIT (Pushbutton panel)

Red LED and green LED.

The table below indicates the malfunctions that may be encountered when the LEDs present in the transmitter unit come on and the relative solutions.

If the problem persists after having implemented the indicated solution, contact the MANITOU assistance service.

Table 205. Malfunctions reported by the transmitter unit (Pushbutton panel)

Reports	Possible causes	Solutions
The green LED flashes quickly. The red LED flashes for minutes.	The battery is not sufficiently charged or the transmitter unit has been switched on for twenty-four hours.	It is necessary to replace the battery with a charged one or it is necessary to turn off the transmitter unit and restart the radio control.
The green LED repeats one or two flashes and a pause. The red LED flashes for minutes.		
The green LED repeats three flashes and a pause. The red LED flashes for minutes.	The transmitter unit has been on for twenty-four hours.	It is necessary to switch off the transmitter unit and restart the radio control.
The green LED is off. The red LED flashes for a very long time.	The transmitter unit is not working properly.	Contact the MANITOU assistance service.
When the remote control is started, the green LED is off and the red LED flashes for a long time.	The GSS or EMS button is pressed.	Disengage the GSS or EMS button.
When starting the remote control, the green LED is off and the red LED makes two long flashes.	The transmitter unit is not working properly.	Contact the MANITOU assistance service.
When the remote control is started, the green LED is off and the red LED makes three long flashes.	The battery is very low.	You need to replace the battery with a charged one.
When the remote control is started, the green LED is off and the red LED makes four long flashes.	The SAFETY command is active.	Bring the actuators to rest position. If this message persists, contact the MANITOU assistance service.
When the remote control is started, the green LED is on and the red LED flashes for a long time and a few short flashes.	At least one of the actuators related to the digital commands is active.	Bring the actuators to rest position. If this message persists, contact the MANITOU assistance service.
When the remote control is started, the green LED is on and the red LED makes two long flashes and a few short flashes.	At least one of the actuators related to the analog commands is active.	
When the remote control is started, the green LED is on and the red LED flashes three long and a few short flashes.	At least one of the actuators related to the direction commands is active.	
When the remote control is started, the green LED is on and the red LED flashes four long and a few short flashes.	At least one of the actuators related to the direction commands is active.	






### MALFUNCTIONS REPORTED BY THE RECEIVING UNIT

The table below indicates the malfunctions that may be encountered when the LEDs on the receiving unit turn on.

If the problem persists after having implemented the indicated solution, contact the MANITOU assistance service.

Table

Table 206. Malfunctions reported by the receiving unit

Reports	Possible causes	Solutions
The POWER LED is off.	The receiving unit is turned off.	Check the integrity of the power supply protection fuse. Connect the connection plug correctly and power up the receiver unit.
	There is an error on the STP_1 output.	Check the integrity of the STP_1 output protection fuse. Attach the connecting plug correctly. Check the correct wiring of the STP_1 output.
	There is an error on the STP_2 output.	Check the integrity of the STP_2 output protection fuse. Attach the connecting plug correctly. Check the correct wiring of the STP_2 output.
	There is an error on the SAF_1 output.	Check the integrity of the SAF_1 output protection fuse (fuse F6). Attach the connecting plug correctly. Check the correct wiring of the SAF_1 output.
	There is an error on the SAF_2 output.	Check the integrity of the SAF_2 output protection fuse. Attach the connecting plug correctly. Check the correct wiring of the SAF_2 output.
The STATUS LED flashes slowly.	There is an overvoltage in the power supply.	Check that the power supply of the receiving unit is within the voltage limits indicated in the technical data.
The STATUS LED flashes intermittently fast.	The receiving unit loses some of the data sent by the transmitting unit.	Move the transmitting unit closer to the receiving unit. If this message persists, contact Manitou Customer Service.
The RUN LED flashes.	The receiving unit does not send commands to the CAN network.	Contact the MANITOU assistance service.
The ERR LED flashes.	There is a CAN communication error.	
	The receiving unit has activated the automatic stop function (ATS) as it carries out a self-test every twenty-four hours of continuous ignition.	Start the remote control
The SETUP LED flashes twice.	There is a memory card error.	Contact the MANITOU assistance service.

### 4.10.7 CHECKING AND CLEANING THE DEF TANK FILLER FILTER

1. Open the access door (1) to the DEF filler cap (2) (3) and unscrew it.
2. Unlock and remove the fuel filter (4) from the filler (3).
3. Clean it with an air jet, check that it is not damaged and if necessary replace it with a new one.
4. Refit the filter (4) and screw the cap (2) back on.

5. Close the access door (1).



Figure 308: Checking and cleaning the DEF tank filler filter

#### 4.10.8 STATIONARY REGENERATION OF DPF FILTER "VEHICLE STOPPED"

### ⚠ DANGER

DPF regeneration is an automated procedure, which is initiated by the operator when the following lights flash:



after 50 hours of operation with an engine speed reduction of 25%.

Park the vehicle in a safe and sufficiently ventilated place.

To perform the regeneration, the system that controls the devices and actions of the exhaust gas after-treatment of the vehicle will check that the following conditions are met:

- Vehicle positioned on tires, not partially or completely stabilized.
- Neutral gear selector.
- Parking brake applied.
- No movement operated (telescopic boom, stabilizers, leveling).
- Telescopic boom in transport position (low and retracted).
- Accelerator pedal released.
- Manual throttle at idle.

Check that the fuel level is sufficient.

Start the vehicle and run the three-phase motor for a few minutes to bring it to operating temperature (60° C - 140° F).



Press the button for more than two seconds to start the automated DPF regeneration procedure. The button lights up (yellow or blue) to indicate that the automated procedure has been activated. An amber

indicator lights up on the display.

Follow the steps indicated on the information display.

### ⚠ DANGER

The DPF regeneration procedure should only be interrupted if necessary. The procedure stops automatically if the operator: Operate the joysticks of the hydraulic movements. Operate the forward or reverse direction selector. Turns off

the three-phase motor. Press the button.



## 4.11. PARKING AND STORAGE

### 4.11.1 PROLONGED INACTIVITY OF THE VEHICLE

If the vehicle is not going to be used for a long period of time, it is necessary to take important maintenance precautions.

- Park the vehicle in a place with a very horizontal and compact surface, possibly protected from weather and against the entry of unauthorized people.
- Place the direction selector on "neutral".
- Activate the parking brake.
- Lower the stabilizers to lighten the load on the tires (depending on vehicle model or equipment).
- Turn the vehicle engine off and remove the key from the dashboard.
- Always keep the cabin door locked.
- Clean the vehicle.
- Replace all lubricants.
- Lubricate all moving parts that are equipped with grease nipples.
- Replace any damaged or excessively worn parts with original spare parts and touch up the paint where necessary to prevent rust from forming.
- Spray or apply a light coat of protective neutral grease on the rods of the hydraulic cylinders and on all unpainted parts of the vehicle.

- Fill the tank up completely with fuel to prevent rust from forming (depending on machine model or equipment).
- Lubricate the external seals of the bodywork with specific lubricants to prevent them from deteriorating.
- Rotate the battery disconnect switch to isolate the batteries from the vehicle's electrical system .



## 5. REFERENCES, OPTIONS AND ACCESSORIES

### 5.1. REFERENCES

#### 5.1.1 LUBRICANTS AND FUEL

**⚠ DANGER**

USE RECOMMENDED LUBRICANTS AND FUEL:  
For topping up, not all oils are mixable.  
For gearboxes, MANITOU oils are perfectly suited.

#### DIAGNOSTIC ANALYSIS OF OILS

In the event of an inspection or maintenance contract concluded with the dealer, a diagnostic analysis of the engine, transmission and axle oils may be required, depending on the utilization rate.

#### CHARACTERISTICS OF THE FUEL REQUIRED

Use a quality fuel to obtain the optimum performance of the internal combustion engine.

- Type of diesel fuel EN590 (sulfur rate <10 ppm).
- ASTM D975 diesel fuel type (sulfur rate <15 ppm).

#### "DEF" SPECIFICATIONS (Diesel Emissions Additive)

- Aqueous solution of urea at 32.5% (ISO22241).
- Solidification at -11° C and expansion of 10%.
- Flammable product.
- Thermal degradation (> 60° C).
- Storage between -5° C and 30° C.

**⚠ WARNING**

#### Risk of corrosive substances

Corrosive product for metals; it is necessary to wear personal protective equipment (gloves and protective goggles).

#### CAPACITIES and RECOMMENDED PRODUCTS MRT 1645, MRT-X 1645, MRT 1845, MRT-X 1845

Table 207. Recommended capacities and products MRT 1645 - 1845 & MRT-X 1645 - 1845

COMPONENTS TO BE LUBRICATED	CAPACITY	RECOMMENDED PRODUCT
<b>THREE-PHASE MOTOR</b>		
THREE-PHASE MOTOR <b>MRT 1645 ST5 - MRT 1845 ST5</b>	11 L - 2.91 US gal	MANITOU EVOLOGY OIL 10W40 API CJ4
THREE-PHASE MOTOR <b>MRT-X 1645 ST3A - MRT-X 1845 ST3A</b>		MANITOU PREMIUM OIL 15W40 API CI4
COOLING SYSTEM	25 L - 6.60 US gal	COOLING SYSTEM -35° C (Concentrated Product)
FUEL TANK	130 L - 34.34 US gal	DIESEL
TANK DEF <b>MRT 1645 ST5 - MRT 1845 ST5</b>	11 L - 2.91 US gal	"DEF" (diesel emissions fluid)
<b>TRANSMISSION</b>		
GEARBOX	1.6 L - 0.42 US gal	SPECIAL MANITOU OIL IMMERSSED BRAKES
CARDAN JOINT		MULTIPURPOSE MANITOU GREASE
<b>TELESCOPIC BOOM</b>		
TELESCOPIC BOOM SHOES		WHITE GREASE PAKELO GREENPLEX EP NLGI 2
CHAIN LUBRICATION		SPRAY OIL MANITOU SPECIAL CHAINS
<b>HYDRAULICS</b>		
HYDRAULIC OIL TANK	144 L - 38.04 US gal	MANITOU ISO VG 46 HYDRAULIC OIL
<b>CABIN</b>		
WINDSCREEN WASHER FLUID TANK	5 L - 1 US gal	WINDSCREEN WASHING FLUID

<b>COMPONENTS TO BE LUBRICATED</b>	<b>CAPACITY</b>	<b>RECOMMENDED PRODUCT</b>
<b>FRONT AXLE</b>		
CENTRAL DIFFERENTIAL	7 L - 1.53 US gal	SPECIAL MANITOU OIL IMMERSSED BRAKES
FINAL REDUCTIONS	2 L - 0.53 US gal (x2)	SPECIAL MANITOU OIL IMMERSSED BRAKES
FINAL REDUCTION PINS		MULTIPURPOSE MANITOU GREASE
<b>REAR AXLE</b>		
CENTRAL DIFFERENTIAL	7.8 L - 1.71 US gal	SPECIAL MANITOU OIL IMMERSSED BRAKES
FINAL REDUCTIONS	0.8 L - 0.21 US gal (x2)	SPECIAL MANITOU OIL IMMERSSED BRAKES
FINAL REDUCTION PINS		MULTIPURPOSE MANITOU GREASE
<b>CHASSIS</b>		
ROTATION REDUCER SHAFT		BLACK MULTIPURPOSE MANITOU GREASE
ROTATION FIFTH WHEEL TOOTHING		BLACK MULTIPURPOSE MANITOU GREASE

**CAPACITIES and RECOMMENDED PRODUCTS****MRT 2145, MRT-X 2145, MRT 2545, MRT-X 2545**

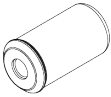


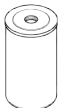






Table 208. Recommended capacities and products MRT 2145 - 2545 & MRT-X 2145 - 2545

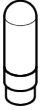




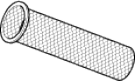

<b>COMPONENTS TO BE LUBRICATED</b>	<b>CAPACITY</b>	<b>RECOMMENDATIONS</b>
<b>THREE-PHASE MOTOR</b>		
THREE-PHASE MOTOR <b>MRT 2145 ST5 - MRT 2545 ST5</b>	11 L - 2.91 US gal	MANITOU EVOLOGY OIL 10W40 API CJ4
THREE-PHASE MOTOR <b>MRT-X 2145 ST3A - MRT-X 2545 ST3A</b>		MANITOU PREMIUM OIL 15W40 API CI4
COOLING SYSTEM	25 L - 6.60 US gal	COOLANT -35° C (Concentrated Product)
FUEL TANK	130 L - 34.34 US gal	DIESEL
DEF TANK <b>MRT 2145 ST5 - MRT 2545 ST5</b>	11 L - 2.91 US gal	"DEF" (diesel emissions fluid)
<b>TRANSMISSION</b>		
GEARBOX	1.6 L - 0.42 US gal	SPECIAL MANITOU OIL IMMERSSED BRAKES
CARDAN JOINT		MULTIPURPOSE MANITOU GREASE
<b>TELESCOPIC BOOM</b>		
TELESCOPIC BOOM SHOES		WHITE GREASE PAKELO GREENPLEX EP NLGI 2
CHAIN LUBRICATION		SPRAY OIL MANITOU SPECIAL CHAINS
<b>HYDRAULICS</b>		
HYDRAULIC OIL TANK	150 L - 39.65 US gal	MANITOU ISO VG 46 HYDRAULIC OIL
<b>CABIN</b>		
WINDSCREEN WASHER FLUID TANK	5 L - 1 US gal	WINDSCREEN WASHING FLUID
<b>FRONT AXLE</b>		
CENTRAL DIFFERENTIAL	7 L - 1.53 US gal	SPECIAL MANITOU OIL IMMERSSED BRAKES
FINAL REDUCTIONS	2 L - 0.53 US gal (x2)	SPECIAL MANITOU OIL IMMERSSED BRAKES
FINAL REDUCTION PINS		MULTIPURPOSE MANITOU GREASE

COMPONENTS TO BE LUBRICATED	CAPACITY	RECOMMENDATIONS
<b>REAR AXLE</b>		
CENTRAL DIFFERENTIAL	7.8 L - 1.71 US gal	SPECIAL MANITOU OIL IMMERSSED BRAKES
FINAL REDUCTIONS	0.8 L - 0.21 US gal (x2)	SPECIAL MANITOU OIL IMMERSSED BRAKES
FINAL REDUCTION PINS		MULTIPURPOSE MANITOU GREASE
<b>CHASSIS</b>		
ROTATION REDUCER SHAFT		BLACK MULTIPURPOSE MANITOU GREASE
ROTATION FIFTH WHEEL TOOTHING		BLACK MULTIPURPOSE MANITOU GREASE

## 5.1.2 FILTER ELEMENTS AND BELTS

Table 209. Filter elements and belts

ELEMENT	DESCRIPTION	OPERATION
<b>500H - PERIODIC MAINTENANCE - EVERY 500 HOURS OF OPERATION OR 6 MONTHS</b>		
	Hydrostatic pump (transmission) oil filter	Replace
	Hydraulic oil filter cartridge (drain)	Replace
	Hydraulic oil breather	Replace
	Engine oil filter	Replace
<b>1000H - PERIODIC MAINTENANCE - EVERY 1000 HOURS OF OPERATION OR 1 YEAR</b> (Also carry out periodic maintenance of the 500 hours of operation)		
	Dry air filter cartridge	Replace
	Fuel pump filter	Check / Clean
	Fuel filter	Replace
	Cabin ventilation filters	Clean / Check
		
	"DEF" fuel pump filter	Replace

ELEMENT	DESCRIPTION	OPERATION
	"DEF" tank breather	Replace
<b>2000H - PERIODIC MAINTENANCE - EVERY 2000 HOURS OF OPERATION OR 2 YEARS</b> (Also perform periodic maintenance of 500 hours and 1000 hours of operation)		
	Hydraulics intake filter cartridges	Clean
		
	Three-phase motor service belt	Replace
<b>3000H - PERIODIC MAINTENANCE - EVERY 3000 HOURS OF OPERATION OR 3 YEARS</b> (Also perform periodic maintenance of 500 hours and 1000 hours of operation)		
	Air filter safety cartridge	Replace
<b>OCCASIONAL MAINTENANCE</b>		
	Fuel tank filler filter	Check / Clean
	DEF tank filler filter	Check / Clean

## 5.2. ATTACHMENTS

### 5.2.1 INTERCHANGEABLE EQUIPMENT AND MACHINE COMPATIBILITY

#### Interchangeable equipment

Interchangeable equipment or attachments are devices which, connected to the machine by the operator, modify the original function of the machine or add a new function. In the case of the telehandler, interchangeable equipment or attachments are for example (non-exhaustive list):

- the platform for lifting people or material,
- the jib & crane for handling suspended loads,
- the winch to lift material,
- etc.

Interchangeable equipment, if supplied by Manitou, is certified, i. e. it is equipped with a certificate of conformity that guarantees optimal safety for the operator and the machine.

#### **⚠ WARNING**

The use of interchangeable attachments or equipment not originally provided on the machine is prohibited.

In the event of subsequent requests for implementation of the machine functions with other attachments, the user, before commissioning, is obliged to request the suitability for use check by an authorized MANITOU technician, who will check the correct functioning and updating of the documentation necessary for the use of the new attachment. Only after this check will the authorization to use the new attachment be issued.

#### **Interchangeable equipment compatible with the machine**

The following tables show the list of interchangeable equipment or attachments compatible with each machine model.

Interchangeable equipment is identified by a code and a description, both reported on the metal plate of the equipment itself.

The compatibility between machine and attachment is certified by Manitou for interchangeable attachments for which the “V” sign appears in the box relating to the machine model.

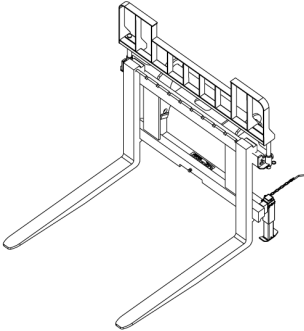
Compatibility between machine and attachment is NOT guaranteed by Manitou for interchangeable attachments for which the “X” sign appears in the box relating to the machine model. This equipment should not be used on the specified machine model.

**⚠ WARNING**

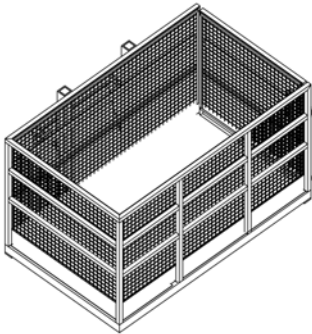
Only attachments approved and certified by MANITOU can be used on telehandlers. The manufacturer's liability will not be involved in the event of modification or use of attachments made without its knowledge.

Use original attachments listed in the machine - attachment or equipment compatibility tables.  
If in doubt, contact your dealer.

**Machine - attachment compatibility table: Forks carriage**

Image	Description	Code (PN)	MRT Vision			
			1645	1845	2145	2545
	<b>CARRIAGE WITH BACKREST AND FLOATING FORKS</b>					
	CAF1030/4.5T F100X60X1200 B	52721040	V	V	V	V
	CAF1030/4.5T F125X50X1500 B	52721110	V	V	V	V
	CAF1030/4.5T F125X50X1800 B	52721112	V	V	V	V
	TFF L1030+FOU 125X50X1200 4.5T	924857	V	V	V	V
	<b>FLOATING FORK CARRIAGE WITH LATERAL DISPLACEMENT</b>					
	TFF L1030+TDL+FOU 125X50X1200	924864	V	V	V	V
	<b>FLOATING FORK CARRIAGE WITH HYDRAULIC LEVELING</b>					
	TFF50CN10°/10°+F.125X50X1200	924876	V	V	V	V
	<b>TILTING FORK CARRIAGE</b>					
	PFB L1320 + FOU- 125X50X1200	924877	V	V	V	V
	PFB L1320 SS DOSS+FORKS	921525	V	V	V	V
	PFB1320+F.FEM3A150X50X1800	52601398	V	V	V	V
	CAT 1750/5T F150X50X1200	52721175	V	V	V	V
	CAT 1750/5T F150X50X1500	52721176	V	V	V	V
	CAT 1750/2.5T F150X50X2000	52721177	V	V	V	V
	CAT 2000/5T F150X50X1200	52721208	V	V	V	V
	CAT 2000/5T F150X50X1500	52721209	V	V	V	V
	CAT 2000/2.5T F150X50X2000	52721210	V	V	V	V
	<b>TILTING FORK CARRIAGE WITH LATERAL DISPLACEMENT</b>					
PFB+TDL FEM3 L1320 SS DOSS+FOR	924878	V	V	V	V	

## Machine - attachment compatibility table: Baskets for materials

Image	Description	Code (PN)	MRT Vision			
			1645	1845	2145	2545
	PANIER DOORS OUTILS	923311	X	V	X	X
	MATERIAL BASKET 2X1.2M 1000KG	52596600				

## Machine - attachment compatibility table: Lifting platforms

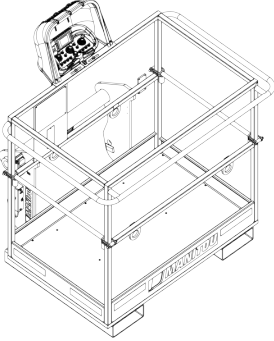
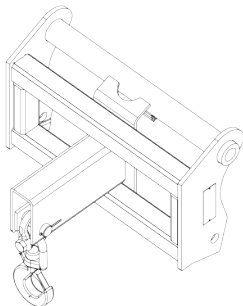
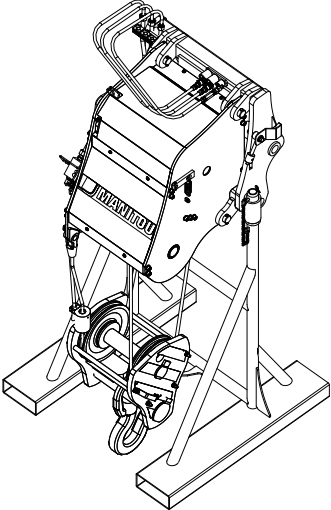
Image	Description	Code (PN)	MRT Vision			
			1645	1845	2145	2545
	<b>STANDARD PLATFORM</b>					
	PF 2000/365	52719245	V	V	V	V
	PS 2000/365	52719246	V	V	V	V
	PF 2000/365	52719658	V	V	V	V
	NACELLE ORH 1.2X0.8 M 365KG (2P) BLACK	921304	V	V	V	V
	NACELLE FIXE 1.2X0.8 M 365KG (2P) BLACK	921296	V	V	V	V
	<b>QUICK-OPEN PLATFORM</b>					
	PSE 4400/365	52719248	V	V	V	V
	PSE 4400/365D	52686224	V	V	V	V
	PSE 4400/365DD	52719250	V	V	V	V
	PSE 4400/700D	52719251	V	V	V	V
	PSE 4400/1000D	52619610	V	V	V	V
	PSE 4400/365	52719665	V	V	V	V
	PSE 4400/700D	52719668	V	V	V	V
	PSE 4400/365	914500	V	V	V	V
	PSE 4400/365 D	939750	V	V	V	V
	PSE 4400/1000 D	939500	V	V	V	V
	PSE 4400/700 D	939020	V	V	V	V
	PSE 4400/365 DD	53012074	V	V	V	V
	PSE 4400/1000D	52719669	V	V	V	V
	PSE 5000/1000D	52719670	V	V	V	V
	<b>EXTENDABLE PLATFORM</b>					
	PSE 5000/365D	52719253	V	V	V	V
	PSE 5000/1000D	52719254	V	V	V	V
	PSE 6000/365D	52719255	V	V	V	V
	ORH EXT. 2.45X5M 365KG (3P)	921309	V	V	V	V
	ORH EXT. 2.45X5M 1000KG (3P)	921308	V	V	V	V
	ORH EXT. 2.45X6M 365KG (3P)	921310	V	V	V	V
	NACELLE ORH EXT 2.25X4M 365KG	921298	X	X	X	X
	NACELLE ORH EXT 2.25X4M 365KG+	921299	X	X	X	X
	NACELLE ORH EXT 2.25X4M 1T 3P	921306	X	X	X	X

Image	Description	Code (PN)	MRT Vision			
			1645	1845	2145	2545
	NACELLE ORH 2.25X4 MT 700KG	923335	X	X	X	X
<b>PLATFORM WITH WINCH</b>						
	PSE 4000/600D +W300/41M	52719257	V	V	V	V
	PSE 4000/450D +W450/35M	52719258	V	V	V	V
	ORH 2.25/4 M 600 KG + POTENCE TREUIL 300 KG	923336	V	V	V	V
	ORH 2.25/4 M 450 KG + POTENCE TREUIL 450 KG	914440	V	V	V	V
<b>ROOF PLATFORM</b>						
	PSR 2400/365	52719259	V	V	V	V
	PSR 2400/1000	52719260	V	V	V	V
	NACELLE COUVREUR 365 KG	923309	V	V	V	V
	NACELLE COUVREUR 1000 KG	921294	V	V	V	V
<b>FIXED ROTARY ROOF PLATFORM</b>						
	PSR 2300/1000F	52719261	V	V	V	V
	NACELLE COUVREUR 1000 KG 2.3X1.2 OUVERTURE FRONT	923323	V	V	V	V
<b>TUNNELING PLATFORM</b>						
	PST 1800/1000 FOPS1	52719262	V	V	V	V
	NACELLE GALLERIE ORH- (1000KG) FOPS1	921356	V	V	V	V
<b>PLATFORM WITH REMOVABLE ROOF</b>						
	PST 3000/1000	52719263	V	V	V	V
	NACELLE RF / P 3X1.2MT. (1000KG)	921357	V	V	V	V
<b>RAISED EXTENDABLE PLATFORM</b>						
	PSE 4000/365D R	52719264	V	V	V	V
	NACELLE SURELEVE2.25-4 365 KG NOIRE	923343	V	V	V	V
<b>DEEP EXTENDABLE PLATFORM</b>						
	PFE 4000/1000 FD	52719265	V	V	V	V
	PSE 4000/700 FD	52719266	V	V	V	V
	NACELLE FIXE EXT.2X2.5 / 4 (1000KG) + FRONT DOORS	921355	V	V	V	V
	NACELLE ORH 40 ° 2x2.5 / 4M (700KG) + FRONT DOORS	921358	V	V	V	V
<b>PLATFORM WITH AERIAL JIB</b>						
	PAJ1 2500/300	52719268	V	V	V	V
	PAJ2 1200/200	52719269	V	V	V	V
	NACELLE AERIAL JIB 2 (200 KG / 2 P)	53027154	V	V	V	V
	NACELLE AERIAL JIB 1 (300 KG / 3 P)	53027148	V	V	V	V
<b>3D SYSTEM</b>						
	P3D 1000/200 L6700	52719363	X	V	X	X
	P3D 1000/200 L7500	52719270	V	X	V	V
	P3D 1000/200 L6700	52719674	X	V	X	X
	P3D 1000/200 L7500	52719672	V	V	V	V
	NACELLE PENDULAIRE AVEC ROTATION (200 KG / 2 P)	53027160	V	X	V	V

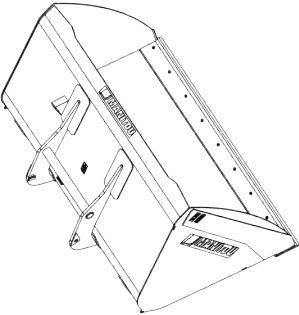
## Machine - attachment compatibility table: Jibs &amp; Cranes

Image	Description	Code (PN)	MRT Vision			
			1645	1845	2145	2545
	<b>FRAME-MOUNTED HOOK</b>					
	PC50	921335	V	V	V	V
	PC60	939050	V	V	V	V
	PC30	921332	V	V	V	V
	PC40	921333	V	V	V	V
	<b>EXTENDABLE JIB</b>					
	P1000	921317	V	V	V	V
	P 1200	921318	V	V	V	V
	P1500	921319	V	V	V	V
	P2000	921320	V	V	V	V
	P600	921316	V	V	V	V
	<b>TWO-HOOK JIB</b>					
	P4000 4T	921321	V	V	V	V
	P6000 6T	921322	V	V	V	V
	<b>EXTENDABLE JIB WITH WINCH</b>					
	PT 800	921323	V	V	V	V
	JWE 7000/800	52717860	V	V	V	V
	<b>EXTENDABLE JIB WITH WINCH</b>					
	PT1000	921326	V	V	V	V
	PT1200	921328	V	V	V	V
	PT600	921325	V	V	V	V
	PT 2000	939392	V	V	V	V
	PT 1500	921330	V	V	V	V
	PT 2000	921331	V	V	V	V
	J2500 W2000/22M	52718250	V	V	V	V
	J2500 W2000/35M	52717582	V	V	V	V
	J3000 W1500/43M	52717710	V	V	V	V
	J4100 W1000/34M	52719497	V	V	V	V
	JW 4100/ 600 68M	52719496	V	V	V	V
	<b>LARGE BAG MANIPULATOR</b>					
	HBB 1500/2400	931627	V	V	V	V

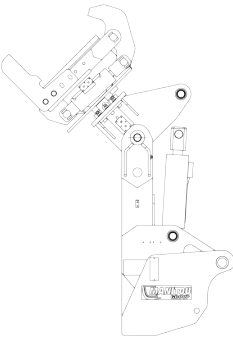
**Machine - attachment compatibility table: Winches**

Image	Description	Code (PN)	MRT Vision			
			1645	1845	2145	2545
	W3000	939393	V	V	V	V
	W3000	921337	V	V	V	V
	W3000	939111	V	V	V	V
	W4000	921338	V	V	V	V
	W5000	939109	V	V	V	V
	W5000	921341	V	V	V	V
	W3000 DI /48M	52717900	V	V	V	V
	W3000/25M	52718245	V	V	V	V
	W3000/36M	52717650	V	V	V	V
	W6000/25M	52717140	V	V	V	V
	W6000/32M	52717351	V	V	V	V

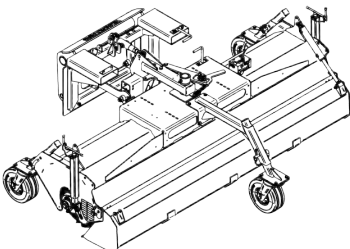
**Machine - attachment compatibility table: Buckets / Loaders**

Image	Description	Code (PN)	MRT Vision			
			1645	1845	2145	2545
	BB 500 MRT	52000642	V	V	V	V
	BBHG 500 MRT	52000643	V	V	V	V
	GL 600H MRT	52553617	V	V	V	V
	CBA 1500 LDR L2450	921279	V	V	V	V
	CBR 1000 L2450	925904	V	V	V	V

**Machine - attachment compatibility table: Centering handler jib & crane**

Image	Description	Code (PN)	MRT Vision			
			1645	1845	2145	2545
	CLR 4000	52721819	V	V	V	V



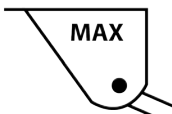
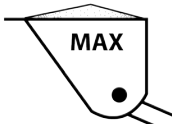
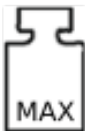


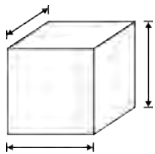
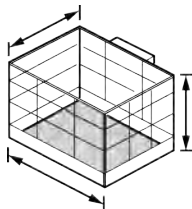
### Machine - attachment compatibility table: Sweeper

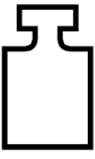


Image	Description	Code (PN)	MRT Vision			
			1645	1845	2145	2545
	SCC 2600 +	52000517	V	V	V	V

## 5.2.2 SYMBOLS AND DESCRIPTION

Below is the key to the symbols used in this chapter:

Table 210. Key to the symbols



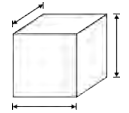
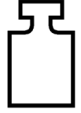
Symbol	Description	Unit of measure
	Manitou product code	-
	Maximum capacity of forks carriage	[kg] (lb)
	Maximum capacity of flush-full bucket	[l] (US gal)
	Nominal maximum capacity of the bucket	[l] (US gal)
	Maximum capacity of the platform	[kg] (lb)
	Maximum capacity of the hook	[kg] (lb)
	Maximum capacity of the gripper	[kg] (lb)
<b>P max</b>	Maximum working pressure of the attachment	[bar] (psi)
	Dimensions of the drawing	[mm] (in)
	Dimensions of the platform	[mm] (in)

Symbol	Description	Unit of measure
	Attachment mass	[kg] (lb)
	Side shift to the left	[mm] (in)
	Side shift to the right	[mm] (in)

### 5.2.3. FORKS CARRIAGE

#### 5.2.3.1 CARRIAGE FLOATING LOAD BACKREST AND FORKS

Table 211. Data table

	[kg] (lb)	[ba- r] (psi)	[mm] (in)												[kg] (lb)
		<i>P<sub>max</sub></i>													
			A	B	C	D	E	F	G	H	I	J	G'	H'	
5272104-0	4500 (9900)	—	1483 (59.32)	1200 (48)	60 (2.4)	1280 (51.2)	308 (12.32)	283 (11.32)	1030 (41.- 2)	830 (33.2)	100 (4)	1127 (45.0- 8)	215 (8.6)	15 (0.6)	330 (726)
5272111-0	4500 (9900)	—	1773 (70.92)	1500 (60)	50 (2)	1280 (51.2)	350 (14)	375 (15)	1030 (41.- 2)	780 (31.2)	125 (5)	1127 (45.0- 8)	265 (10.6)	15 (0.6)	375 (825)
5272111-2	4500 (9900)	—	2073 (82.92)	1800 (72)	50 (2)	1280 (51.2)	377 (15.08)	467 (18.6- 8)	1030 (41.- 2)	780 (31.2)	125 (5)	1127 (45.0- 8)	265 (10.6)	15 (0.6)	410 (902)
924857	4500 (9900)	—	1473 (58.92)	1200 (48)	50 (2)	1280 (51.2)	316 (12.64)	292 (11.68)	1030 (41.- 2)	780 (31.2)	125 (5)	1127 (45.0- 8)	265 (10.6)	15 (0.6)	340 (748)

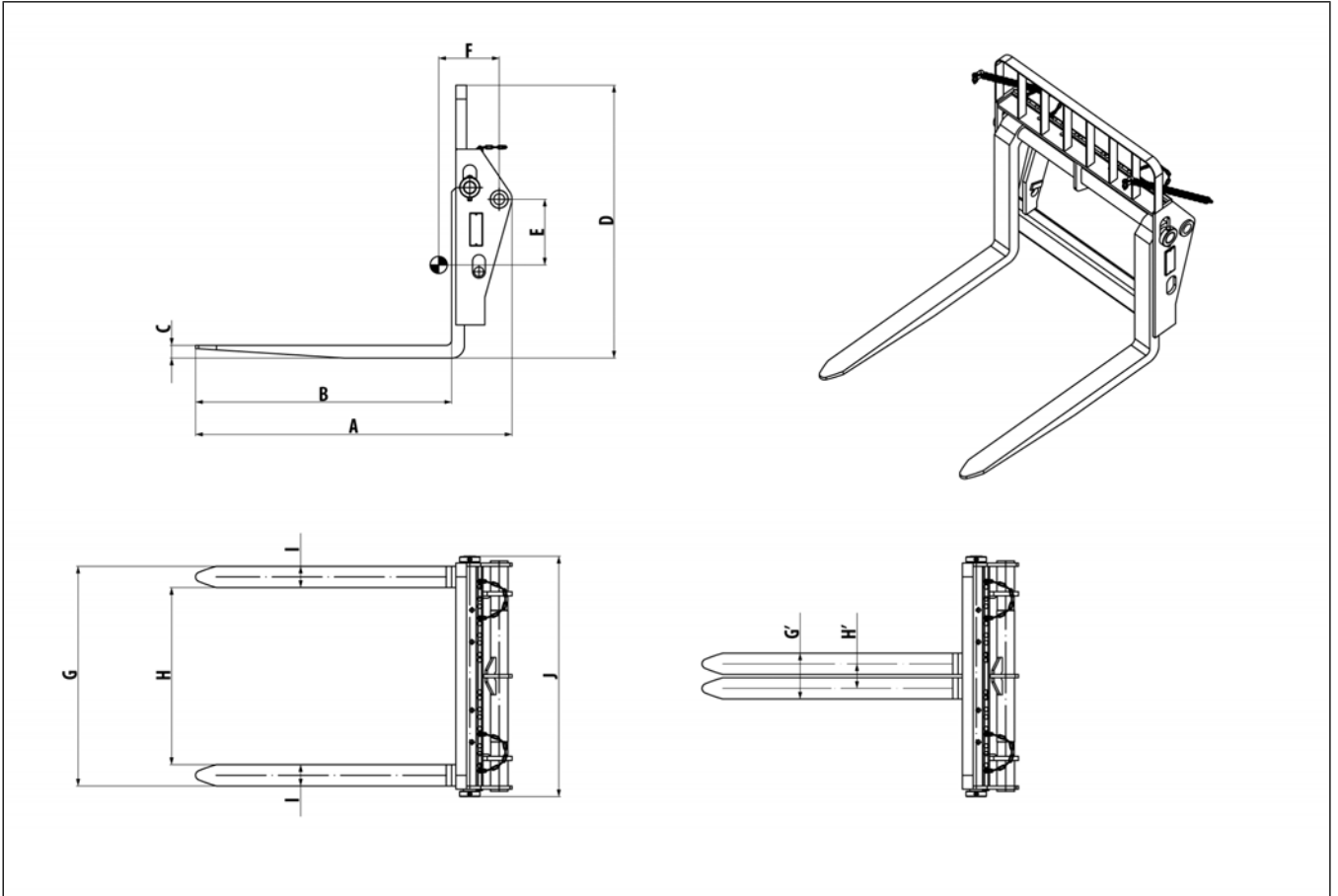


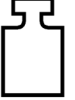




Figure 309: Attachment dimensions

5.2.3.2 FLOATING FORK CARRIAGE WITH SIDE SHIFT

Table 212. Data table

		[kg] (lb)  [bar] (psi)  P max	[mm] (in)													
			A	B	C	D	E	F	G	H	H'	I	I'	J	K	
924864	4000 (8800)	270 (39-15)	1662 (66.48)	1200 (48)	50 (2)	1481 (59.2-4)	496 (19.84)	338 (13.5-2)	1128 (45.-12)	1028 (41.1-2)	360 (14.4)	778 (31.1-2)	110 (4.4)	125 (5)	1032 (41.28)	532 (1170.-4)

[mm] (in)	[mm] (in)
	
100 (4)	100 (4)

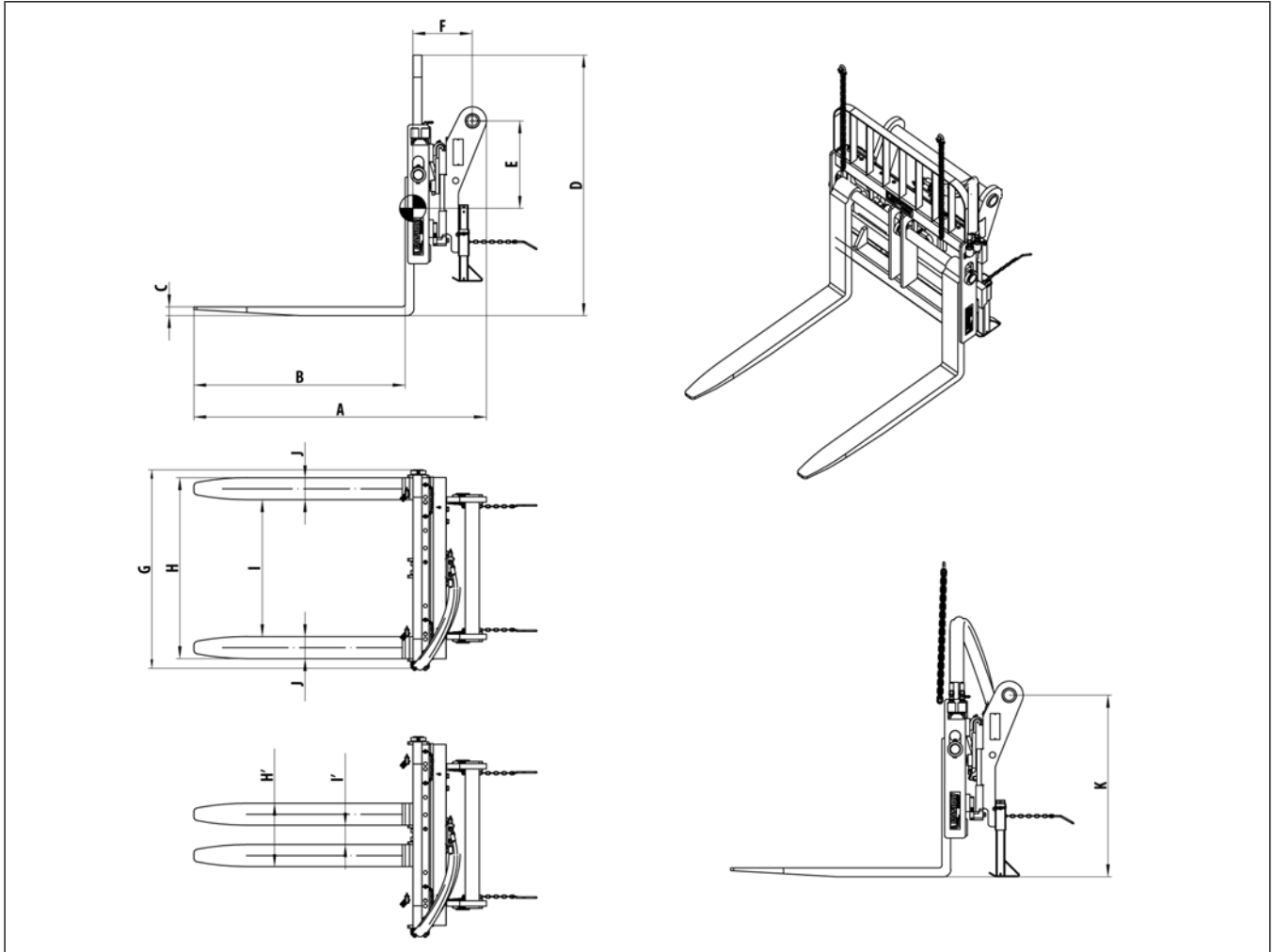



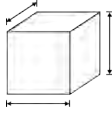
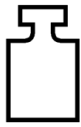


Figure 310: Attachment dimensions

### 5.2.3.3 FLOATING FORK CARRIAGE WITH HYDRAULIC LEVELING

Table 213. Data table

	[kg] (lb)	[bar] (psi)	[mm] (in)										[kg] (lb)	
			A	B	C	D	E	F	G	H	I	J		K
 		<b>P<sub>max</sub></b>												
			924876	4900 (10780)	270 (391-5)	1545 (61.8)	1200 (48)	50 (2)	1420 (56.8)	116 (4.64)	258 (10.32)	1010 (40.4)		760 (30.4)

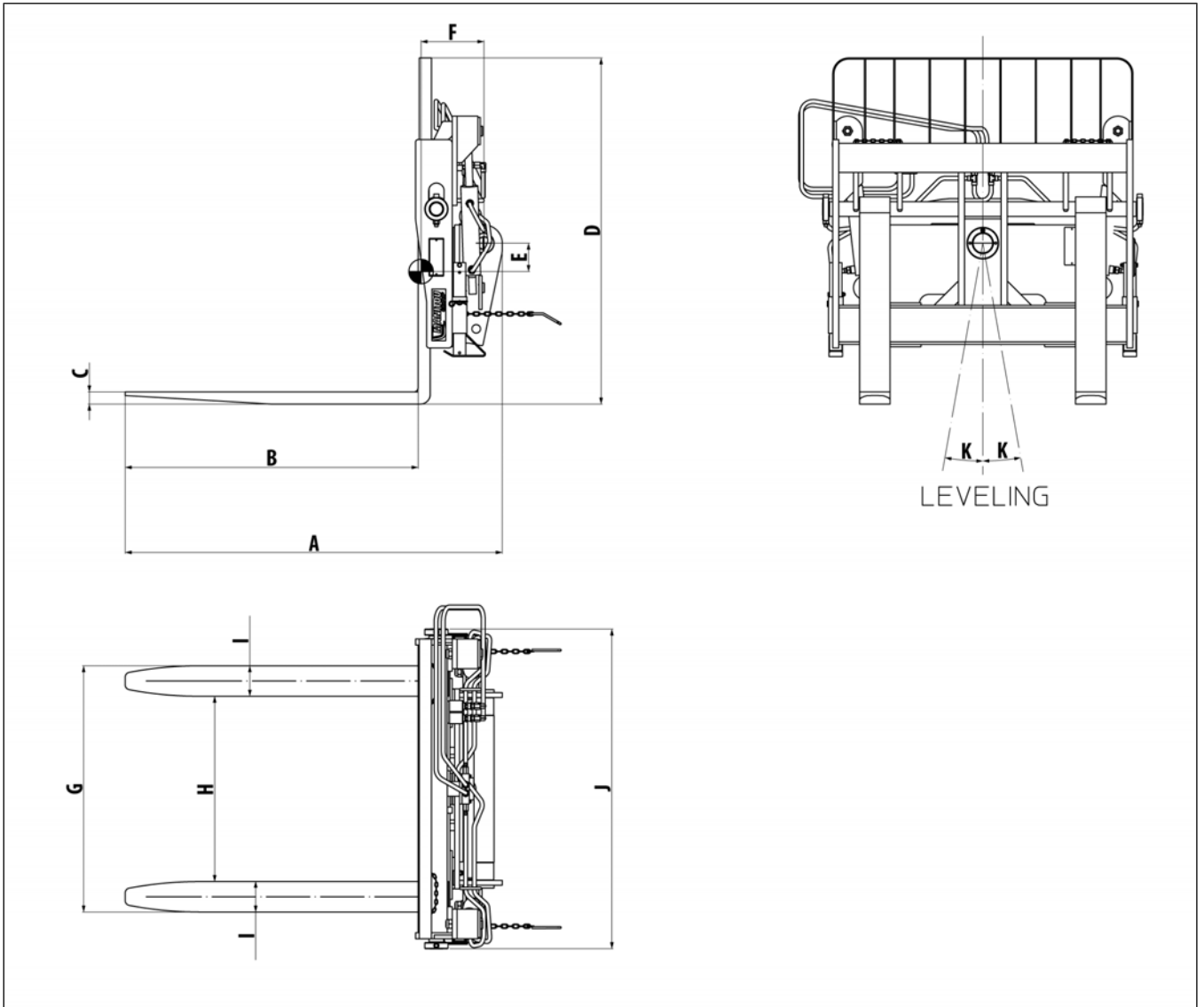


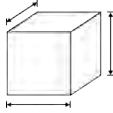
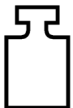


Figure 311: Attachment dimensions

5.2.3.4 TILTING FORK CARRIAGE

Table 214. Data table

	[kg] (lb)	[bar] (psi)	[mm] (in)													[kg] (lb)
			A	B	C	D	E	F	G	G'	H	H'	I	J	K	
		$P_{max}$														
9248-77	4500 (9900)	—	1519 (60.76)	1200 (48)	50 (2)	818 (32.7-2)	452 (18.08)	318 (12.7-2)	1125 (45)	458 (18.3-2)	875 (35)	208 (8.32)	125 (5)	1404 (56.1-6)	1094 (43.7-6)	363 (798.6)
9215-25	4999 (1099-7.8)	—	1819 (72.76)	1500 (60)	50 (2)	819 (32.7-6)	487 (19.48)	411 (16.4-4)	1242 (49.-68)	482 (19.2-8)	942 (37.68)	182 (7.28)	150 (6)	1404 (56.1-6)	1095 (43.8)	411 (904.2)
5260-1398	4999 (1099-7.8)	—	2119 (84.76)	1800 (72)	50 (2)	819 (32.7-6)	494 (19.76)	490 (19.6)	1242 (49.-68)	480 (19.2)	942 (37.68)	180 (7.2)	150 (6)	1404 (56.1-6)	1095 (43.8)	442 (972.4)

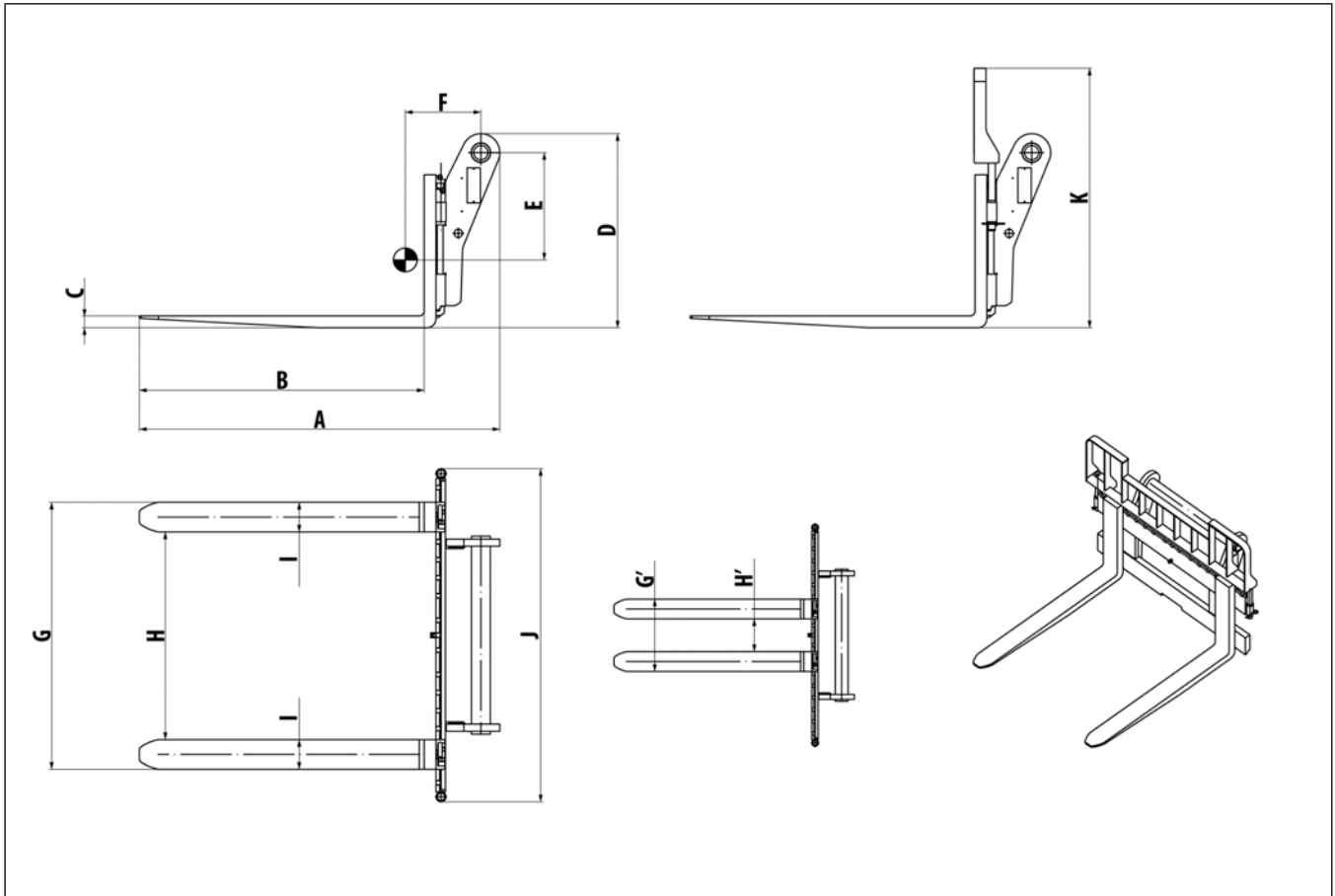



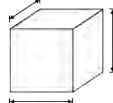
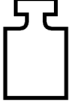


Figure 312: Attachment dimensions

Table 215. Data table

	[kg] (lb)	[ba- r] (ps- i)	[mm] (in)													[kg] (lb)
 		<i>P</i> <i>max</i>														
			A	B	C	D	E	F	G	G'	H	H'	I	J	K	
527211-75	5000 (1100-0)	—	1518 (60,72)	1200 (48)	50 (2)	819 (32,7-6)	419 (16,76)	294 (11,7-6)	1698 (67,-92)	482 (19,-28)	1398 (55,92)	182 (7,28)	150 (6)	1834 (73,3-6)	1095 (43,8)	432 (950.4)
527211-76	5000 (1100-0)	—	1818 (72,72)	1500 (60)	50 (2)	819 (32,7-6)	479 (19,16)	377 (15,0-8)	1698 (67,-92)	482 (19,-28)	1398 (55,92)	182 (7,28)	150 (6)	1834 (73,3-6)	1095 (43,8)	465 (1023)
527211-77	5000 (1100-0)	—	2320 (92,8)	2000 (80)	50 (2)	820 (32,8)	506 (20,24)	549 (21,9-6)	1698 (67,-92)	482 (19,-28)	1398 (55,92)	182 (7,28)	150 (6)	1834 (73,3-6)	1096 (43,8-4)	540 (1188)

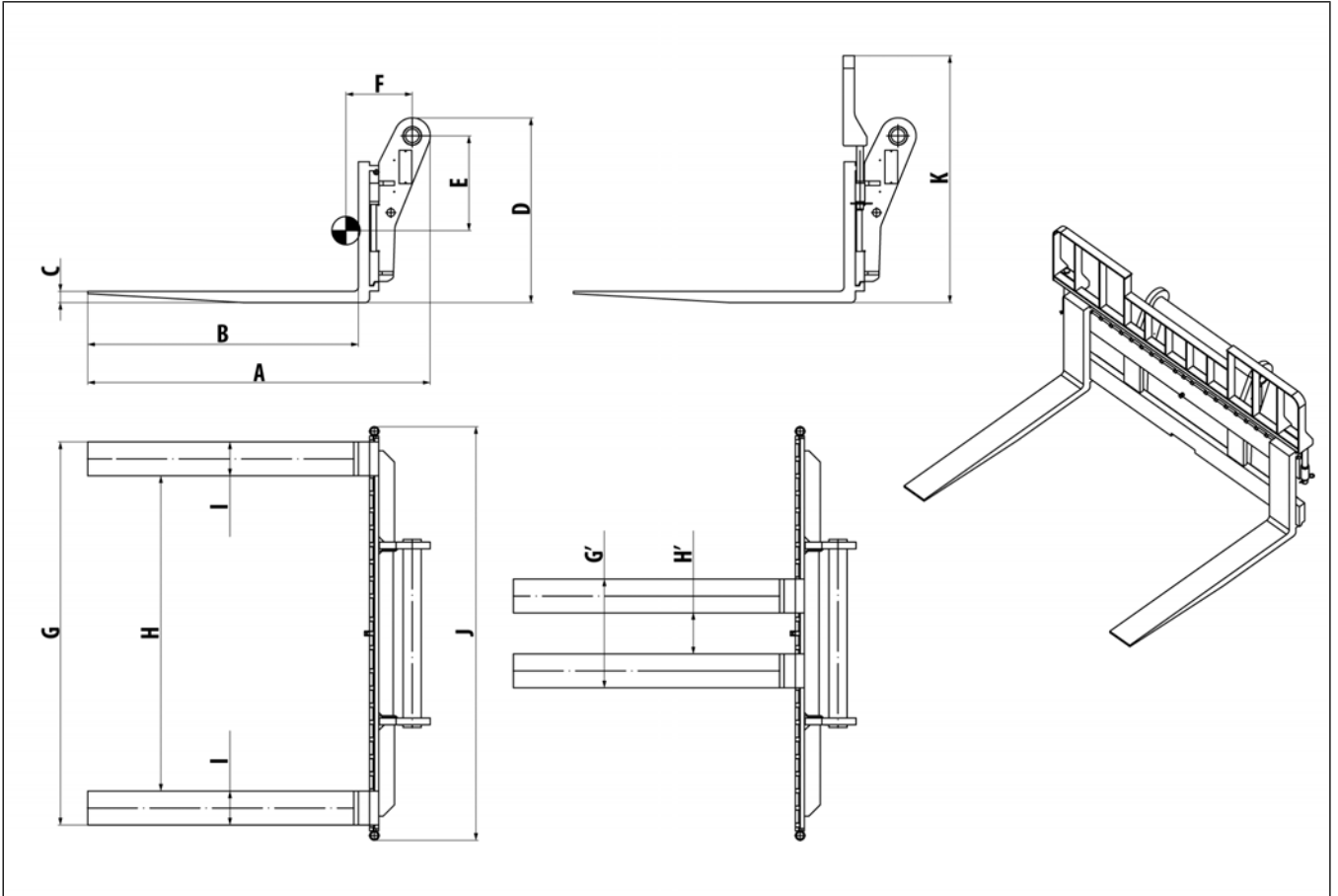


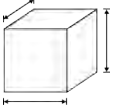



Figure 313: Attachment dimensions

Table 216. Data table

	[kg] (lb)	[bar] (psi)	[mm] (in)													[kg] (lb)
			A	B	C	D	E	F	G	G'	H	H'	I	J	K	
		$P_{max}$														
527212-08	5000 (1100-0)	—	1519 (60,76)	1200 (48)	50 (2)	819 (32,7-6)	456 (18,24)	290 (11,6)	1850 (74)	482 (19,-28)	1550 (62)	182 (7,28)	150 (6)	2084 (83,3-6)	1095 (43,8)	471 (1036.-2)
527212-09	5000 (1100-0)	—	1819 (72,76)	1500 (60)	50 (2)	819 (32,7-6)	475 (19)	362 (14,4-8)	1850 (74)	482 (19,-28)	1550 (62)	182 (7,28)	150 (6)	2084 (83,3-6)	1095 (43,8)	505 (1111)
527212-10	5000 (1100-0)	—	2321 (92,84)	2000 (80)	50 (2)	820 (32,8)	499 (19,96)	523 (20,9-2)	1850 (74)	482 (19,-28)	1550 (62)	182 (7,28)	150 (6)	2084 (83,3-6)	1096 (43,8-4)	582 (1280.-4)

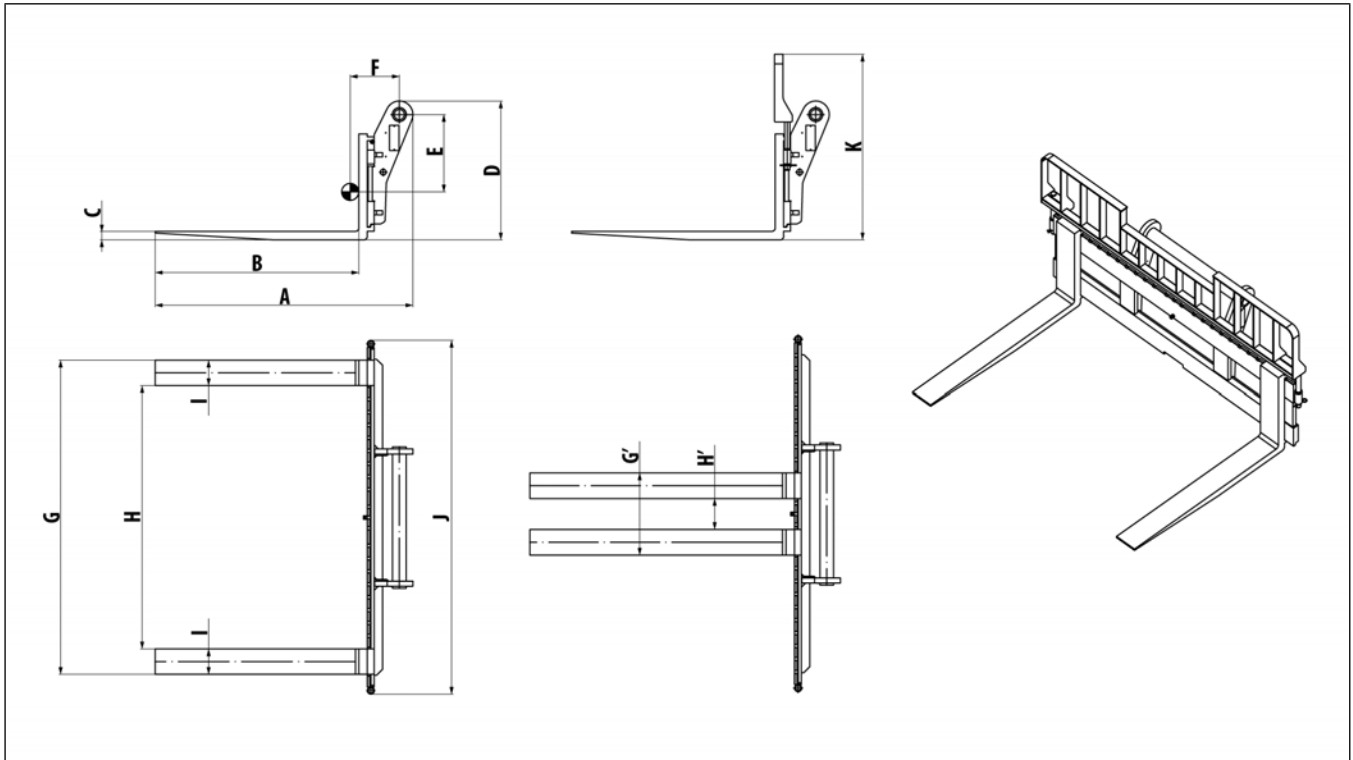


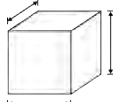
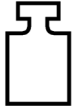




Figure 314: Attachment dimensions

### 5.2.3.5 TILTING FORK CARRIAGE WITH SIDE SHIFT

Table 217. Data table

	[kg] (lb)	[bar] (psi)	[mm] (in)													[kg] (lb)
			A	B	C	D	E	F	G	G'	H	H'	I	J	K	
  <b>P<sub>max</sub></b>																
			9248-78	4500 (9900)	270 (39-15)	1596 (63,84)	1200 (48)	50 (2)	821 (32,8-4)	437 (17,48)	300 (12)	1292 (51,-68)	392 (15,6-8)	1042 (41,68)	142 (5,68)	125 (5)

[mm] (in)	[mm] (in)
	
100 (4)	100 (4)

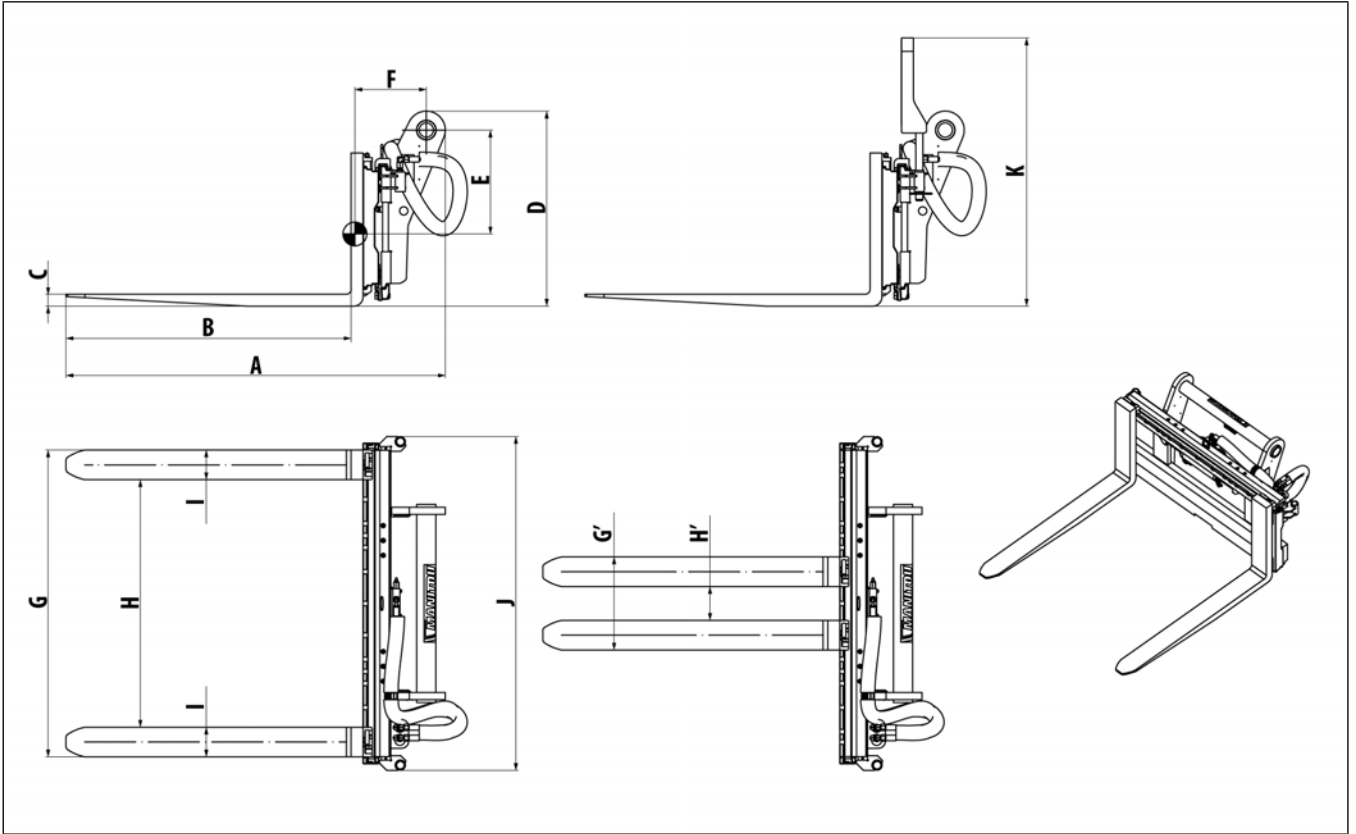


Figure 315: Attachment dimensions

## 5.2.4. BUCKETS

### 5.2.4.1 GENERAL PURPOSE BUCKET

Table 218. Data table

	[l] (US gal)	[l] (US gal)	[bar] (psi)	[mm] (in)									[kg] (lb)
			<i>P max</i>	A	B	C	D	E	F	G	H	I	
	1000 (2200)	—	—	2400 (96)	2450 (98)	775 (31)	340,6 (13.62-4)	905 (36.2)	857,5 (34.3)	214,4 (8.576)	400 (16)	105 (4.2)	410 (902)

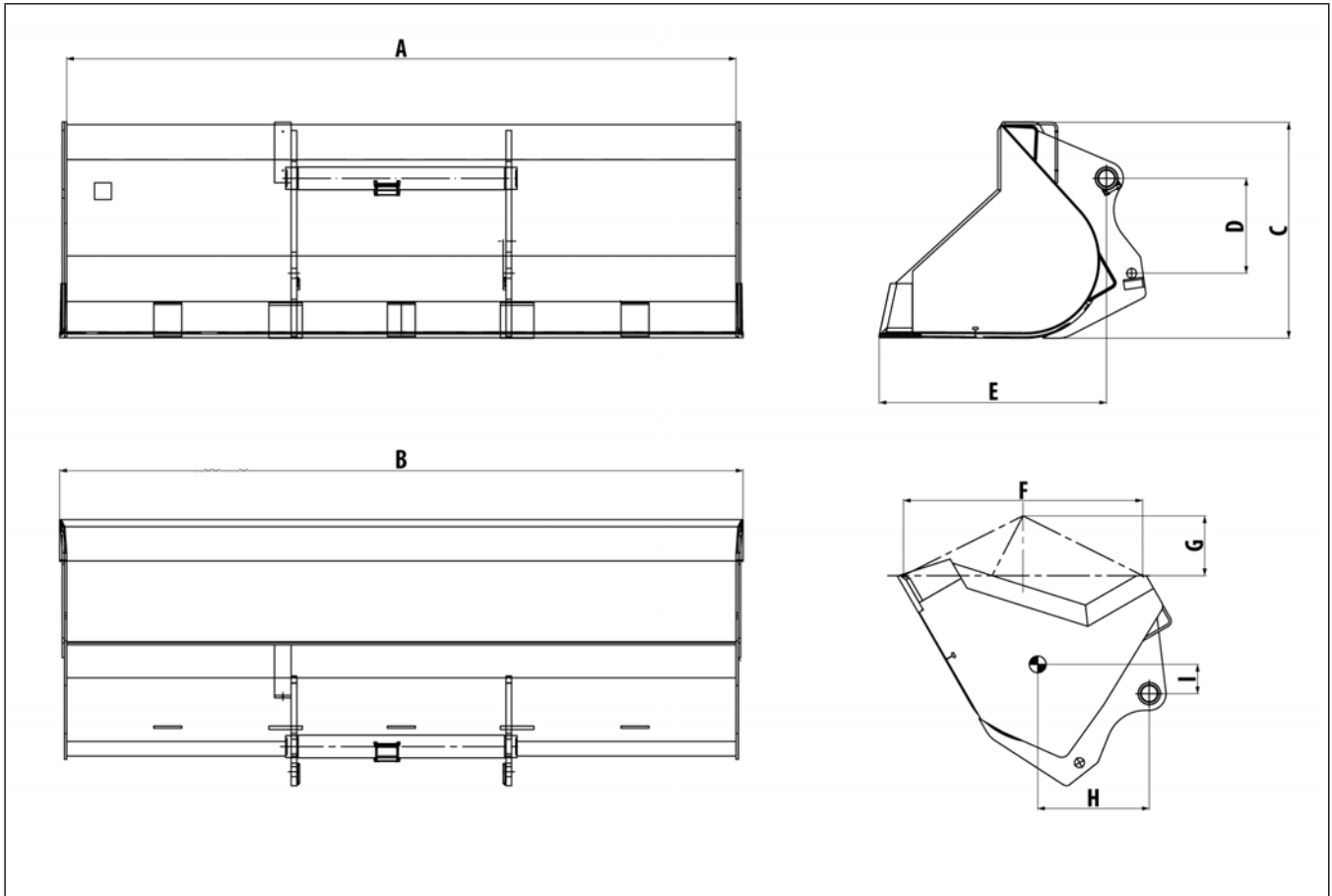
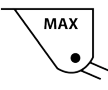
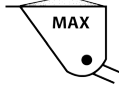
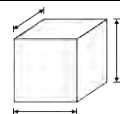
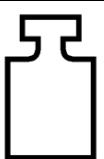


Figure 316: Attachment dimensions

5.2.4.2 LIGHT MATERIAL BUCKET

CBA 1500 / 2450

Table 219. Data table

	[l] (US gal)	[l] (US gal)	[bar] (psi)	[mm] (in)						[kg] (lb)
			<i>P max</i>							
				A	B	C	D	E	F	
921279	1101 (286.26)	1529 (397.54)	—	1011 (40.44)	2450 (98)	2418 (96.72)	996.5 (39.86)	696 (27.84)	329 (13.16)	620 (1364)

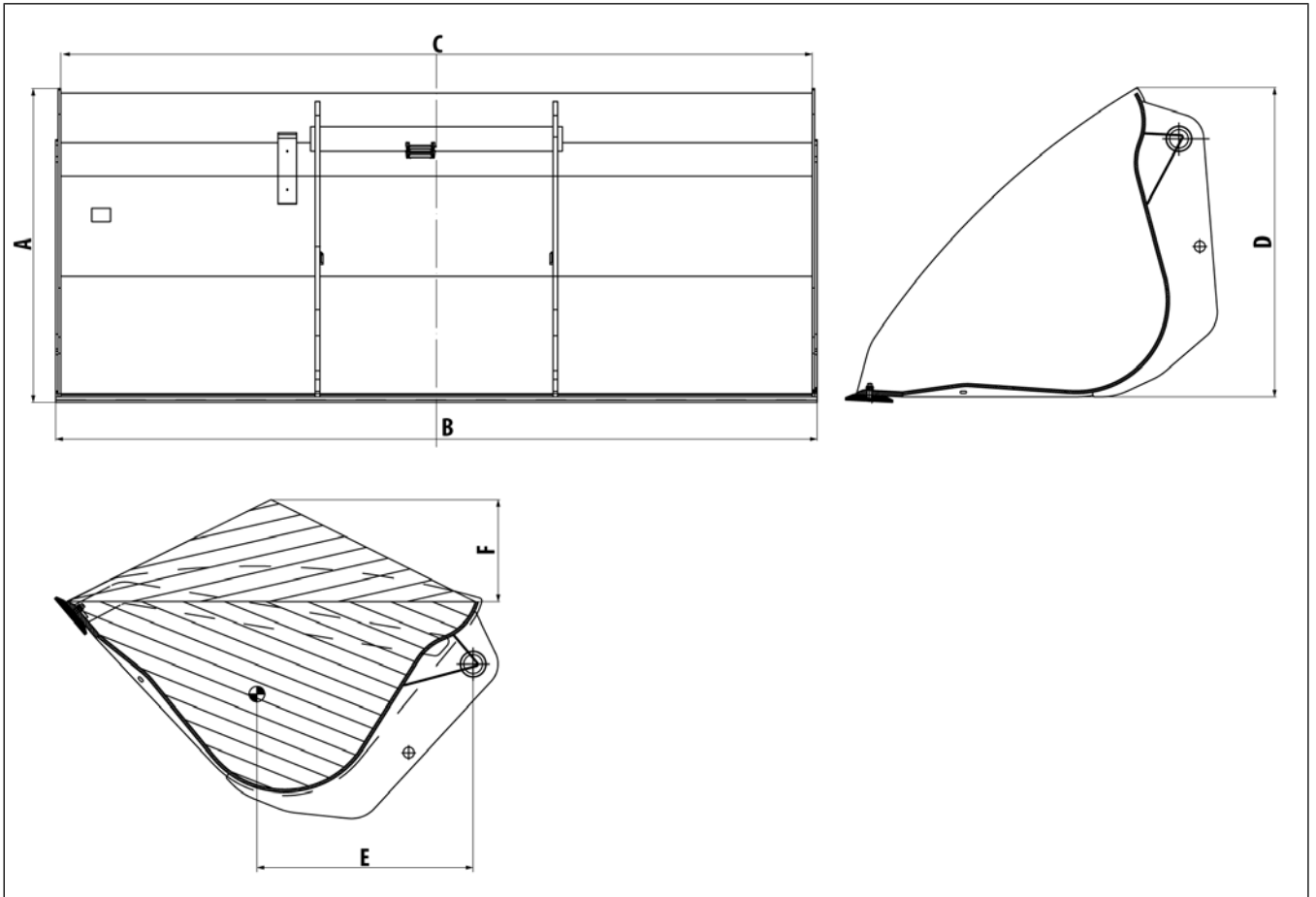


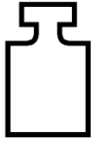


Figure 317: Attachment dimensions

## 5.2.4.3 CONCRETE SKIP

## BB 500 MRT

Table 220. Data table

	[l] (US gal)	[l] (US gal)	[bar] (psi)	[mm] (in)								[kg] (lb)
			<i>P max</i>	A	B	C	D	E	F	G	H	
52000-642	500 (130)	—	—	776 (31.04)	720 (28.8)	327 (13.08)	208 (8.32)	668 (26.72)	555 (22.2)	1216 (48.64)	1466 (58.64)	210 (462)

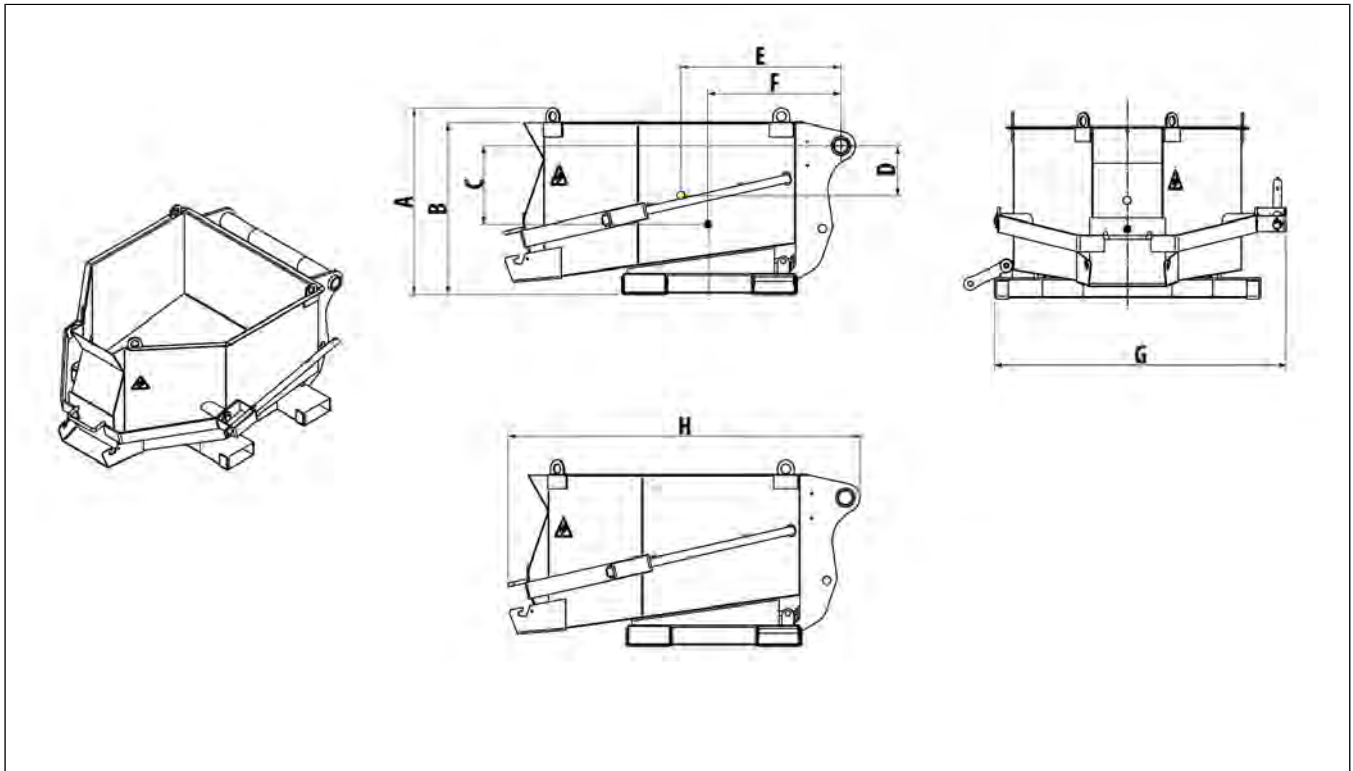
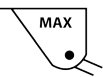
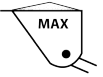
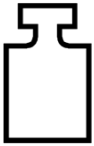


Figure 318: Attachment dimensions

- : center of gravity with loaded bucket.
- : center of gravity with unloaded bucket.

**BB 500 MRT**

Table 221. Data table

	[l] (US gal)	[l] (US gal)	[bar] (psi)	[mm] (in)								[kg] (lb)
			<i>P max</i>	A	B	C	D	E	F	G	H	
52000-643	500 (130)	—	250 (3625)	676 (27.04)	621 (24.84)	210 (8.4)	329 (13.16)	776 (31.04)	720 (28.8)	1110 (44.4)	1466 (58.64)	220 (8.8)

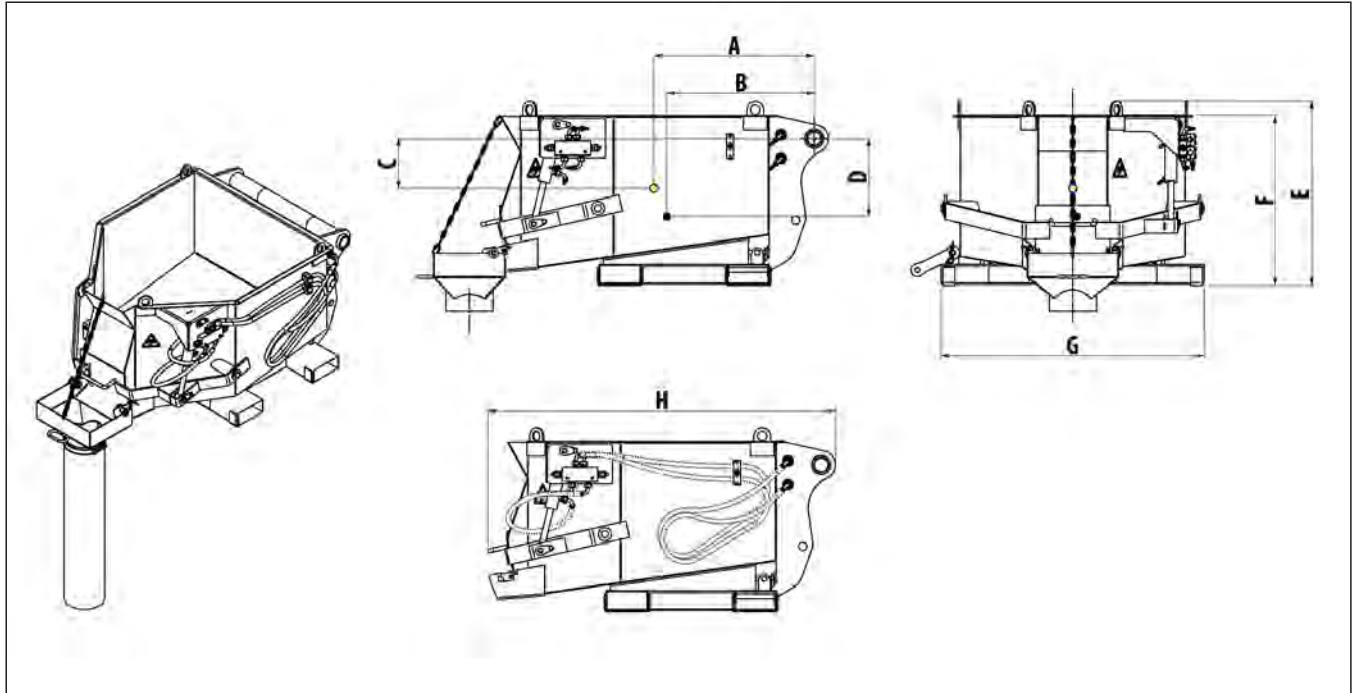


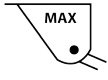
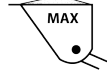
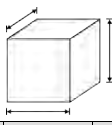
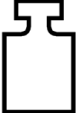
Figure 319: Attachment dimensions

- : center of gravity with loaded bucket.
- : center of gravity with unloaded bucket.

## 5.2.4.4 CRANE SKIP

## GL 600 H MRT

Table 222. Data table

	[l] (US gal)	[l] (US gal)	[bar] (psi)	[mm] (in)									[kg] (lb)
			<i>P max</i>										
				A	B	C	D	E	F	G	H	I	
52553617	600 (156)	—	—	1119 (44.76)	726 (29.04)	468 (18.72)	127 (5.08)	58 (2.32)	1326 (53.04)	1197 (47.88)	1300 (52)	995 (39.8)	245 (539)

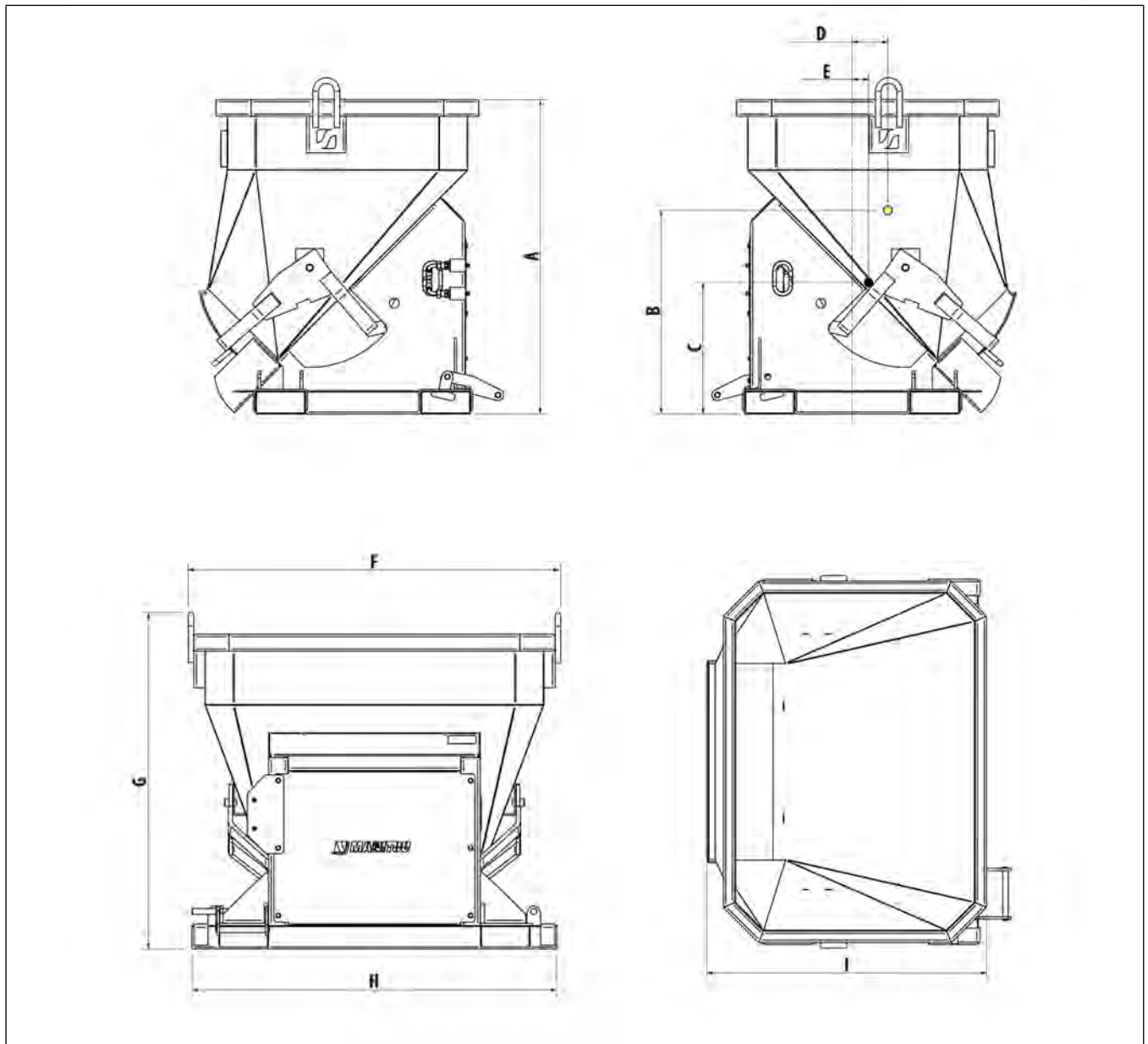


Figure 320: Attachment dimensions

- YELLOW: center of gravity with loaded bucket.
- BLACK: center of gravity with unloaded bucket.

# Index

55 kW engine .....	57
85 kW engine .....	74

## A

Attachments .....	330
-------------------	-----

## B

Before using the machine .....	231
Buckets .....	345

## C

Check indicators .....	194
Components .....	158

## D

Decals description .....	37
Decals location .....	32
Display .....	172
Driving instructions .....	16
Driving the machine .....	241

## E

Emergency procedures .....	249
Enter the cabin .....	235
Environment .....	144
Every 10 hours of operation or daily .....	261
Every 1000 hours of operation or every 2 years .....	291
Every 2000 hours of operation or every 4 years .....	304
Every 250 hours of operation or every 6 months .....	279
Every 3000 hours of operation or every 6 years .....	307
Every 50 hours of operation or weekly .....	270
Every 500 hours of operation or every 1 years .....	286

## F

Forks carriage .....	338
----------------------	-----

## G

General instructions .....	15
----------------------------	----

## H

Handling instructions .....	19
Handling of a load .....	21

## I

Information for the environment .....	31
Instructions for using the radio control .....	25

## M

Machine identification .....	49
Main parts of the vehicle .....	29
Maintenance .....	257
Maintenance intervals .....	257

## O

Occasional maintenance .....	308
Operator area .....	168
Optional .....	209

## P

Parking and storage .....	324
---------------------------	-----

## R

References .....	327
References, options and accessories .....	327

## S

Safety .....	13
Scheduled maintenance .....	257
SETTINGS page .....	186
Stability of the machine .....	246

## T

Technical data and description .....	49
Technical specifications .....	53
Telehandler maintenance instructions .....	28
Transport of the machine .....	251
Turning the machine on and off .....	236

## U

Use of attachments .....	237
Use of the machine .....	231
Use of towing devices .....	250
Using the stabilizers .....	246

For Support and Service, Contact Your Dealer

