



**647739 EN (20/10/2025)**

MT 420 H 57K ST5 S1  
MT 420 HTSS 57K ST5 S1

**OPERATOR'S MANUAL**  
**(ORIGINAL MANUAL)**

## **IMPORTANT**

*Carefully read and understand this instruction manual before using this machine.*

*It contains all information relating to operation, handling and equipment, as well as important recommendations to be followed.*

*This document also contains precautions for use, as well as information on the service and routine maintenance required to ensure the machine's continued reliability and safety of use.*

**WHENEVER YOU SEE THIS SYMBOL, IT MEANS:**



**PLEASE NOTE! BE CAREFUL! YOUR SAFETY, THAT OF OTHERS, OR THE SAFETY OF THE MACHINE IS AT RISK.**

- This manual has been produced based on the equipment list and technical characteristics given at the time of its design.
- The machine's equipment level depends on the options chosen and the country of sale.
- Depending on the machine's options and the date of sale, certain equipment or functions described in this manual may not be present on this machine.
- Descriptions and figures are non-binding.
- MANITOU reserves the right to change its models and their equipment without being required to update this manual.
- The MANITOU network, consisting exclusively of qualified professionals, is available to answer all your questions.
- This manual is an integral part of the machine.
- It is to be kept in its storage location at all times for ease of reference.
- Give this manual to the new owner if the machine is resold.

**1<sup>st</sup> EDITION**

**28/01/2019**

**UPDATED**

<b>26/11/2019</b>	<b>2-6 – 2-9 ; 2-20 ; 2-23 ; 2-26 ; 2-36 ; 2-39 – 2-40 ; 2-48 – 2-50 ; 2-53 – 2-54 3-11 ; 3-20</b>
<b>26/03/2021</b>	<b>1-6 ; 1-10 ; 1-15 ; 1-25 ; 1-26 2-8 ; 2-9 ; 2-13 : 2-18 ; 2-32 ; 2-33 ; 2-44 ; 2-50 3-7 ; 3-8 ; 3-30 ; 3-31 ; 3-39</b>
<b>15/11/2022</b>	<b>UKCA</b>
<b>14/05/2025</b>	<b>0-0 1-1 – 1-34 2-6 – 2-7 ; 2-51 3-9 ; 3-11 4-9</b>
<b>20/10/2025</b>	<b>0-0 3-24 ; 3-34 4-9</b>

*The brochure and all its contents, including diagrams, are the proprietary and confidential intellectual property of Manitou BF and / or its subsidiaries ("Manitou Group"). Any reproduction, publication or dissemination of any part of the brochure without the express written authorization of Manitou Group is strictly prohibited. Any violation of this provision will subject the offending party to prosecution by Manitou Group to the fullest extent of the law. The logos and the company's visual identity are the property of Manitou Group and may not be used without the express written authorization of Manitou Group.*

*All trademarks, registered and unregistered, is and shall remain the property of Manitou BF or its respective owner.*

*Any reproduction, source code access, decompilation, modification, copy (other than backup copies), correction of errors, transmission or distribution of any software built into Manitou Group machines is strictly prohibited.*

*In the event that the measures above nevertheless prove essential to enable use of the software, in accordance with its destination, or to obtain the information required for interoperability with other software created independently, the user should contact Manitou Group in advance and Manitou may, at its sole discretion, take the necessary measures or give access to only the information strictly necessary for interoperability.*

*Any breach of these requirements is likely to constitute a counterfeiting offense subject to legal action by Manitou Group.*

*Connected Manitou Group machines are equipped with boxes that collect technical data on the machines (such as geo-tracking data or data on component operation). This data, which is organized, processed and enhanced by algorithms and expertise proprietary to Manitou Group, constitutes, in combination with other elements, independent or not, a protected database according to laws & regulations on IP purposes.*

*It is strictly forbidden to have access to all or part of this database and to use the data (including in the event of accidental access) without explicit prior authorization from Manitou Group. In the event that Manitou Group authorizes a Manitou Group machine user to access all or part of this database, Manitou Group, as producer of this database, cedes to the user only a right to personal, non-exclusive, non transferable use of the database, and only by access to an information technology platform hosted by a server owned or controlled by Manitou Group.*

*In any case, the following are strictly prohibited:*

- any extraction, reproduction, representation, reuse through provision to the public, distribution, transfer, permanent or temporary, on any medium, by any means, and in any form whatsoever, of all or of a qualitatively or quantitatively substantial part of the contents of this database,*
- any extraction, reproduction, representation, reuse through provision to the public, distribution, transfer, repeated or systematic of qualitatively or quantitatively insubstantial parts of the content of the database during operations manifestly exceeding normal use of the database by the user of the machine for his own needs,*
- any use of means to bypass technical protection measures for databases or software source code embedded in the boxes, in keeping according to laws & regulations on IP purposes.*

*The latest updated version in force and binding of this document is the version available on demand.*

*Only the electronic version is maintained.*

*MANITOU BF S.A. Public limited company with a board of directors.*

*Head office: 430 rue de l'Aubinière - 44150 Ancenis - France*

*Share capital: €39,548,949*

*Entered in the Nantes Trade and Companies Register under number 857 802 508.*

*Tel.: +33 (0) 2 40 09 10 11*

*www.manitou.com*

**1 - OPERATING AND SAFETY INSTRUCTIONS**

**2 - DESCRIPTION**

**3 - MAINTENANCE**

**4 - OPTIONAL ADAPTABLE ATTACHMENTS FOR THE RANGE**





# ***1 - OPERATING AND SAFETY INSTRUCTIONS***

# 1 - OPERATING AND SAFETY INSTRUCTIONS

## **INSTRUCTIONS TO THE COMPANY MANAGER**

**1-4**

<b>THE SITE</b>	<b>1-4</b>
<b>THE OPERATOR</b>	<b>1-4</b>
<b>THE MACHINE</b>	<b>1-4</b>
A - SUITABILITY OF THE MACHINE FOR THE TASK . . . . .	1-4
B - ADAPTING THE MACHINE TO USUAL ENVIRONMENTAL CONDITIONS . . . . .	1-4
C - MODIFYING THE MACHINE. . . . .	1-5
D - FRENCH ROAD TRAFFIC RULES. . . . .	1-5
E - MACHINE CAB PROTECTION. . . . .	1-5
<b>INSTRUCTIONS</b>	<b>1-6</b>
<b>MAINTENANCE</b>	<b>1-6</b>

## **INSTRUCTIONS FOR THE OPERATOR**

**1-8**

<b>FOREWORD</b>	<b>1-8</b>
<b>GENERAL INSTRUCTIONS</b>	<b>1-8</b>
A - OPERATOR'S MANUAL . . . . .	1-8
B - AUTHORIZATION FOR USE IN FRANCE. . . . .	1-8
C - MAINTENANCE . . . . .	1-9
D - TIRES . . . . .	1-9
E - MODIFYING THE MACHINE. . . . .	1-9
F - LIFTING PEOPLE. . . . .	1-9
<b>MACHINE OPERATING INSTRUCTIONS UNLADEN AND LADEN</b>	<b>1-10</b>
A - BEFORE OPERATING THE MACHINE. . . . .	1-10
B - AVAILABLE IN THE DRIVER'S CAB. . . . .	1-10
C - ENVIRONMENT . . . . .	1-10
D - VISIBILITY . . . . .	1-11
E - STARTING THE MACHINE . . . . .	1-12
F - OPERATING THE MACHINE . . . . .	1-12
G - STOPPING THE MACHINE. . . . .	1-14
H - DRIVING THE MACHINE ON THE PUBLIC HIGHWAY. . . . .	1-15
<b>INSTRUCTIONS FOR HANDLING A LOAD</b>	<b>1-18</b>
A - CHOICE OF ATTACHMENTS . . . . .	1-18
B - WEIGHT OF LOAD AND CENTER OF GRAVITY . . . . .	1-18
C - LONGITUDINAL STABILITY LIMITER AND WARNING DEVICE. . . . .	1-18
D - LATERAL TILTING OF THE MACHINE . . . . .	1-19
E - PICKING UP A LOAD ON THE GROUND . . . . .	1-19
F - PICKING UP AND PUTTING DOWN A HIGH LOAD ON TIRES . . . . .	1-20
G - PICKING UP AND PUTTING DOWN A HIGH LOAD ON STABILIZERS. . . . .	1-22
H - PICKING UP AND PUTTING DOWN A SUSPENDED LOAD. . . . .	1-24
I - TRAVELING WITH A SUSPENDED LOAD. . . . .	1-24
<b>INSTRUCTIONS FOR USE AS A LOADER</b>	<b>1-25</b>
A - LOADING . . . . .	1-25
B - BACKFILLING. . . . .	1-25
<b>OPERATING INSTRUCTIONS FOR MACHINE WITH PLATFORM</b>	<b>1-26</b>
A - AUTHORIZATION TO OPERATE THE MACHINE WITH PLATFORM. . . . .	1-26
B - SUITABILITY OF THE MACHINE FOR PLATFORM USE . . . . .	1-26
C - PROVIDED ON THE PLATFORM . . . . .	1-26
D - USING THE PLATFORM. . . . .	1-26
E - ENVIRONMENT . . . . .	1-27
F - MAINTENANCE . . . . .	1-28
<b>INSTRUCTIONS FOR USING THE RADIO-CONTROL</b>	<b>1-29</b>
HOW TO USE THE RADIO-CONTROL. . . . .	1-29
SAFETY DEVICES . . . . .	1-29

**MACHINE MAINTENANCE INSTRUCTIONS** **1-30**

---

**GENERAL INSTRUCTIONS** **1-30**

**PLACING THE LIFTING STRUCTURE SAFETY WEDGE** **1-30**

**MAINTENANCE** **1-31**

    MAINTENANCE LOGBOOK ..... 1-31

**LUBRICANT AND FUEL LEVELS** **1-31**

**HYDRAULICS** **1-31**

**ELECTRICITY** **1-31**

**WELDING ON THE MACHINE** **1-31**

**WASHING THE MACHINE** **1-32**

**TRANSPORTING THE MACHINE** **1-32**

**PROLONGED MACHINE SHUTDOWN** **1-32**

---

**INTRODUCTION** **1-32**

**PREPARATION OF THE MACHINE** **1-32**

**DEF (Diesel Exhaust Fluid) TANK** **1-32**

**PROTECTING THE ENGINE** **1-33**

**MACHINE PROTECTION** **1-33**

**RETURNING THE MACHINE TO SERVICE** **1-33**

**DISPOSING OF THE MACHINE** **1-34**

---

**RECYCLING OF MATERIALS** **1-34**

    METALS ..... 1-34

    PLASTICS ..... 1-34

    RUBBER ..... 1-34

    GLASS ..... 1-34

**ENVIRONMENTAL PROTECTION** **1-34**

    WORN OR DAMAGED PARTS ..... 1-34

    USED OIL ..... 1-34

    USED BATTERIES ..... 1-34

# INSTRUCTIONS TO THE COMPANY MANAGER

## THE SITE

Proper management of the machine's area of travel will reduce the risk of accidents:

- ground not unnecessarily uneven or obstructed,
- no excessive slopes,
- pedestrian traffic controlled, etc.

## THE OPERATOR

- Only qualified, authorized personnel can use the machine. This authorization is given in writing by the appropriate person in the establishment where the machine is to be used and must be carried permanently by the operator.

### ⚠ IMPORTANT ⚠

*Experience has shown that there are a number of inappropriate ways in which the machine might be operated. Such foreseeable misuse, of which the main examples are listed below, are strictly forbidden.*

*- The foreseeable abnormal behavior resulting from ordinary negligence, but not from any intentional misuse of the equipment.*

*- The reflex reactions of a person in the event of a malfunction, incident, fault, etc. during operation of the machine.*

*- Behavior resulting from application of the "principle of least effort" when performing a task.*

*- For certain machines, the foreseeable behavior of such persons as: apprentices, teenagers, handicapped persons, trainees tempted to drive a machine, operators tempted to operate a machine to win a bet, in competition or for their own personal experience.*

*The person in charge of the equipment must take these criteria into account when assessing whether or not a person will make a suitable driver.*

## THE MACHINE

### A - SUITABILITY OF THE MACHINE FOR THE TASK

- MANITOU has ensured that this machine is suitable for use under the standard operating conditions defined in this operator's manual, with a **STATIC TEST COEFFICIENT OF 1.25** and a **DYNAMIC TEST COEFFICIENT OF 1**, as specified in harmonized standard **EN 1459** for variable reach machines.
- Before commissioning, the facility manager must make sure that the machine is appropriate for the work to be done, and perform certain tests (in accordance with applicable legislation).

### B - ADAPTING THE MACHINE TO USUAL ENVIRONMENTAL CONDITIONS

#### ⚠ IMPORTANT ⚠

*For operation under average climatic conditions, lubricants are topped up to the correct levels in the factory, i.e. between -15 °C to +35 °C*

*For operation under more severe climatic conditions, before starting up, drain all circuits then fill using lubricants suitable for the ambient temperatures.*

*The same applies to the coolant.*

#### ⚠ IMPORTANT ⚠

*The machines are designed for outdoor use under normal atmospheric conditions and indoor use in suitably aerated and ventilated premises. It is prohibited to operate the machine in areas which presents a risk of fire or which are potentially explosive (e.g. refineries, fuel or gas depots, stores of flammable products, etc.).*

*Specialized equipment is available when operating in these areas (ask your dealer for information).*

- Our machines are designed to be used within a temperature range of -18 °C to +43 °C.
- In addition to the standard equipment fitted on your machine, many options are available, such as: road lighting, stop lights, rotating beacon light, reverse lights, front worklight, rear worklight, lifting structure worklight, etc. (depending on machine model).
- The operator must take into account the operating conditions to specify the machine's signaling and lighting equipment. Consult your dealer.
- Take into account the climatic and atmospheric conditions of the operation site. Consult your dealer for the suitability of lubricants and frost protection.
- Take into account the fire risk associated with use in dusty and flammable conditions (e.g. straw, flour, sawdust, organic waste, etc.).
- A machine operating in an area without fire extinguishing equipment must be equipped with an individual extinguisher. Solutions exist, consult your dealer.

Our machines comply with Directive 2014/30/EU (2015/208/EU for our type-approved "TRACTOR" machines) concerning electromagnetic compatibility (EMC), (UK : Electromagnetic Compatibility Regulations 2016) and with the corresponding harmonized standard EN 12895. Their correct operation is no longer guaranteed if they are used within areas in which the electromagnetic fields exceed the limit specified by this standard (20 V/m).

- Directive 2002/44/EC requires company managers to not expose their employees to excessive vibration doses. There is no recognized code of measurement for comparing the machines of different manufacturers. The actual doses received cannot therefore be measured under actual operating conditions at the user's premises.
- The following are some tips for minimizing these vibration doses:
  - Select the most suitable machine and attachment for the intended use.
  - Adapt the seat adjustment to the operator's weight (**depending on machine model**) and maintain it in good condition, as well as the cab suspensions. Inflate the tires in accordance with recommendations.
  - The seat is an essential way of reducing the vibrations transmitted to the operator. In the event of seat replacement, please contact MANITOU.
  - Ensure that the operators adapt their operating speed to suit the conditions on site.
  - As far as possible, arrange the site in such a way as to provide a flat running surface and remove obstacles and harmful potholes.

## C - MODIFYING THE MACHINE



**Modifying the structure and settings of the various components of your machine (hydraulic pressure, taring of limiters, engine speed, sensors, addition of extra equipment, addition of counterweights, unapproved and unauthorized attachments, alarm systems, etc.) yourself is strictly prohibited. In this case, the manufacturer cannot be held responsible.**

## D - FRENCH ROAD TRAFFIC RULES

(or see current legislation in other countries)

- Only one EC declaration of conformity is issued. It must be kept in a safe place.
- The road traffic rules for the machines are subject to the provisions of the highway code, according to the following categories:
  - Construction machinery (MT range): public works vehicle not predominantly for use on roads (point 6.9 of Article R.311-1 of the French Highway Code). The machine must have a 25 disc displayed on the rear of the machine and an operating license plate.
  - Non-type-approved "Tractor" machinery for agricultural work: (point 6.2 of Article R.311-1 of the French Highway Code). The machine must be fitted with an operating license plate.
  - Type-approved "Tractor" machinery for agricultural work: Agricultural tractor type T1a (point 5.1.1 of Article R.311-1 of the French Highway Code). The machine must be licensed.

## SPECIAL INSTRUCTIONS APPLICABLE TO TYPE-APPROVED "TRACTOR" MACHINES

- All approved machines are supplied with a "Tractor" certificate of compliance with Regulation 167/2013, to be retained by the owner, and a page of administrative details together with a CNIT number (national type approval code) for registration at the prefecture.
- The owner of the machine is responsible for carrying out the necessary procedures for obtaining the vehicle registration document within the time limit defined by the regulations.
- The operator must hold a category B driver's license, unless granted an exemption.
- The machine must be driven on the public highway in accordance with the instructions given in the operator's manual supplied with the machine (Gross weight, Gross combination weight, towing load, axle loads, maximum speeds, etc. according to the type/version). The operator must be in possession of the machine's registration document.



**When towing a trailer or agricultural equipment, the traveling speed of the machine is limited to 25 km/h.**

**In this case, a "25" disc must be affixed to the rear of the convoy.**

## E - MACHINE CAB PROTECTION

- All machines comply with standard ISO 3471 Roll-over Protective Structures (ROPS)
- All machines comply with standard ISO 3449 Falling-Object Protective Structures (FOPS) (Level I or II) (↔ 2 - DESCRIPTION OF STICKERS AND PLATES)
- The windows used on our machines comply with standard ECE-R43 Operator Protective Structures (OPS).
- Approved "TRACTOR" machines also comply with the regulations:
  - (appendix 1322/2014-OCDE Code 4).
  - (appendix 1322/2014-OCDE Code 10).



**Structural damage or overturning, a modification, changes or a poorly executed repair can reduce the protective efficiency of the cab, canceling its compliance.**

**Do not perform welding or drilling on the cab structure.**

**Consult your dealer to determine the limits of this structure without canceling its compliance.**

## **INSTRUCTIONS**

---

- The operator's manual must always be in good condition, in the language of the operator and placed in the storage compartment provided.
- You must replace the operator's manual, as well as any plates or stickers, if they are damaged or no longer legible.

## **MAINTENANCE**

---

**⚠ IMPORTANT ⚠**

*Refer to chapter: MACHINE MAINTENANCE INSTRUCTIONS.*

**⚠ IMPORTANT ⚠**

*Your machine must be periodically inspected to ensure its continued compliance.*

*The frequency of this inspection is defined by the legislation in force in the country in which the machine is used.*

- Maintenance or repairs other than those detailed in Part: 3 - MAINTENANCE must be carried out by qualified personnel (consult your dealer) and in the necessary safety conditions to preserve the health of the operator and any third party.
- Example for France "The manager in charge of the establishment using a machine must open and maintain a maintenance log for each machine (order of March 2, 2004) and undergo a general periodic inspection every 6 months (order of March 1, 2004)".



# INSTRUCTIONS FOR THE OPERATOR

## FOREWORD

### **⚠ IMPORTANT ⚠**

*The risk of accident while using, servicing or repairing this machine can be reduced if you follow the safety instructions and preventive measures detailed in this operator's manual.*

*Failure to respect the safety and operating instructions, or the instructions for repairing or servicing this machine may lead to serious accidents or even death.*

### **⚠ IMPORTANT ⚠**

*In order to reduce or prevent any danger with a MANITOU-approved attachment, follow the instructions in paragraph: 4 - ADAPTABLE ATTACHMENTS AVAILABLE ON THE RANGE: INTRODUCTION.*

- Only the operations and maneuvers described in this operator's manual must be performed. The manufacturer cannot predict all possible risky situations. Consequently, the safety instructions given in this operator's manual and on the machine itself are not exhaustive.
- As an operator, you must at all times give reasonable consideration to the possible risks to yourself, to others or to the machine when you use it.
- The operator is responsible for the machine in all circumstances, regardless of whether he is present in the driver's cab.

## GENERAL INSTRUCTIONS

### A - OPERATOR'S MANUAL

#### **⚠ IMPORTANT ⚠**

*Carefully read and understand this operator's manual before operating this machine.*

- The operator's manual must always be in good condition, in the language of the operator and placed in the storage compartment provided.
- You must replace the operator's manual, as well as any plates or stickers, if they are no longer legible, missing or damaged.
- Any operations or maneuvers not described in the operator's manual are forbidden.
- Follow the safety advice and the instructions described on the machine's decals.
- Familiarize yourself with the machine on the ground where it will be operated.
- The machine must also be operated in accordance with the professional standards.

### B - AUTHORIZATION FOR USE IN FRANCE

*(or see current legislation in other countries).*

- Only qualified, authorized operators may use this machine. Qualified operators must have been trained for the type of machine used. This authorization is given in writing by the appropriate person in the establishment where the machine is to be used and must be carried by the operators at all times.
- The operator is not cleared to authorize the driving of the machine by another person.

## C - MAINTENANCE



*Do not use the machine if the wheels are damaged or excessively worn, because this could put your own safety or that of others at risk, or cause damage to the machine.*

- The operator must carry out the daily maintenance (↖ 3 - MAINTENANCE) before using the machine in his place of work.
- If the operator sees that the machine is not in good working order or does not comply with the safety instructions, he must inform his manager of this immediately.
- The operator is prohibited from carrying out any repairs or adjustments himself, unless he has been trained for this purpose. He must keep the machine properly cleaned if this is his responsibility.
- The operator is responsible for deciding and adjusting the frequency and type of the cleaning needed to prevent the risk of fire ensuing from the build-up of flammable material(s). The operator should pay special attention to all the areas of the machine where these high-risk materials are likely to accumulate (e.g. engine compartment, under the lifting structure, above the axles, inside the chassis, etc.).

## D - TIRES



*Do not use the machine if the tires are damaged or excessively worn, because this could put your own safety or that of others at risk, or cause damage to the machine itself.*

*The fitting of foam inflated tires is prohibited and is not guaranteed by the manufacturer unless with prior authorization.*

- The operator must ensure tires are suitable for the nature of the ground (see contact surface with the ground for the tires in the chapter: 2 - DESCRIPTION: TIRES). Optional solutions are available, please consult your dealer.
  - SAND tires.
  - FARM tires.
  - Snow chains.
- The machine's four tires must be the same brand, the same dimensions, the same structure (radial or diagonal) and the same usage category (normal, snow or special), and must have the same degree of tread wear.
- In the event of tire replacement, use tires authorized by MANITOU that are the same type and dimensions. Using different tires voids the machine's type approval and you may be liable.
- If you are replacing just one of the machine's tires (e.g. because it is damaged), we recommend choosing a tire with the same degree of wear as the remaining tires so as not to damage the transmission's kinematic chain.

## E - MODIFYING THE MACHINE

- ↖ INSTRUCTIONS TO THE COMPANY MANAGER: ↖ C - MODIFYING THE MACHINE.

## F - LIFTING PEOPLE

- The use of working equipment and load lifting attachments to lift people is:
  - either forbidden
  - or authorized exceptionally and under certain conditions (↖ regulations in force in the country in which the machine is used).
- The pictogram posted at the operator station reminds you that:
  - Left-hand column
    - It is forbidden to lift people, with any kind of attachment, using a non PLATFORM-fitted machine.
  - Right-hand column
    - With a PLATFORM-fitted machine, people can only be lifted using platforms designed by MANITOU for this purpose.
- MANITOU sells equipment specifically designed for lifting people (OPTION PLATFORM-fitted machine; contact your dealer).

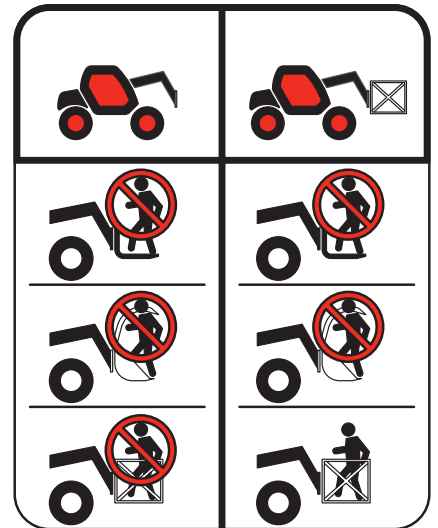

**A - BEFORE OPERATING THE MACHINE**

- Make sure that the driver's cab is clean, particularly the floor and floor mat. Check that no movable object may hinder the operation of the machine.
- Make sure the lights, turn signals and windshield wipers are working properly.
- Make sure the rear-view mirrors are in good condition, clean and properly adjusted.
- Make sure the horn works.
- Perform the daily maintenance operations (<math>\leq 3</math> - MAINTENANCE).

**B - AVAILABLE IN THE DRIVER'S CAB**

- Whatever his experience, the operator is advised to familiarize himself with the position and operation of all the controls and instruments before operating the machine.
- Wear clothes suitable for driving the machine, avoid loose clothing.
- Make sure you have the appropriate protective equipment for the task to be performed.
- Prolonged exposure to high noise levels may cause hearing problems. It is recommended to wear ear muffs to protect against excessive noise.
- Always face the driver's cab access when getting in and out of the lift truck and use the handle(s) provided for this purpose. Do not jump out of the machine.
- Remain alert at all times when using the machine. Do not listen to the radio or music using headphones or earphones.
- Never use the machine with hands or shoes that are wet or soiled with greasy substances.
- For increased comfort, adjust the seat to your requirements and adopt the correct position in the driver's cab.



*Under no circumstances must the seat be adjusted while the machine is moving.*

- The operator must always be in his normal position in the driver's cab: Arms and legs, and generally any part of the body, should be kept inside the driver's cab of the machine.
- The safety belt must be worn and adjusted to the operator's size.
- The control units must never be used for any other than their intended purposes (e.g. Climbing onto or down from the machine, coat hanger, etc.).
- If the control components are fitted with a forced operation (lever lock) device, it is forbidden to leave the cab without first putting these controls in neutral.
- It is prohibited to carry passengers either on the machine or in the cab.

**C - ENVIRONMENT**

- Comply with site safety regulations.
- If you have to use the machine in a dark area or at night, make sure it is equipped with worklights.
- During handling operations, make sure that no one is in the way of the machine and its load.
- Do not allow anybody to come near the working area of the machine or pass beneath an elevated load.
- The maximum slope on which the machine can be used in relation to the capacity of the brake is 20%.
- When using the lift truck on a transverse slope, before lifting the lifting structures, observe the instructions given in the paragraph: INSTRUCTIONS FOR HANDLING A LOAD: D - LATERAL TILTING OF THE MACHINE.
- Traveling on a longitudinal slope:
  - Drive and brake gently.

- Moving without load: Forks or attachment facing downhill.

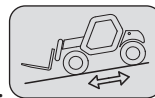

- Moving with load: Forks or attachment facing uphill.

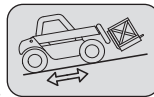

- Take into account the machine's dimensions and its load before trying to negotiate a narrow or low passageway.
- Never move onto a load bridge without having first checked:
  - That it is suitably positioned and made fast.
  - That the unit to which it is connected (wagon, truck, etc.) will not shift.
  - That this bridge is prescribed for the total weight of the machine, laden or unladen.
  - That this bridge is prescribed for the size of the machine.

- Never move onto a foot bridge, floor or freight lift, without ensuring that they are suitable for the mass and size of the machine, and without checking that they are in good condition.
- Be careful in the area of loading bays, trenches, scaffolding, soft ground and manholes.
- Make sure that the ground is stable and firm under the wheels and/or stabilizers before lifting or extending the telescopic boom. If necessary, add appropriate wedging under the stabilizers (depending on the model).
- Make sure that the scaffolding, loading platform, pilings or ground is capable of bearing the load.
- Never stack loads on uneven ground, they may tip over.

**⚠ IMPORTANT ⚠**

*If the load or the attachment must remain above a structure for a prolonged period of time, there is the risk that it will bear on the structure as the lifting structure descends due to cooling of the oil in the cylinders.*

*To eliminate this risk:*

*- Regularly check the distance between the load or the attachment and the structure and readjust this if necessary.*

*- If possible use the machine at an oil temperature as close as possible to ambient temperature.*

- In the case of work near to overhead lines, ensure that the safety distance is sufficient between the machine's working area and the overhead line.

**⚠ IMPORTANT ⚠**

*Do not operate this machine during thunderstorms, snowstorms, periods of frost, or in hazardous weather conditions.*

**⚠ IMPORTANT ⚠**

*You must consult your local electrical supplier.*

*You could be electrocuted or seriously injured if you operate or park the machine too close to power lines.*

*In the event of high winds, do not carry out handling work that jeopardizes the stability of the machine and its load, particularly if the load catches the wind badly.*

- Prevent the fire risk associated with use in dusty and flammable conditions (e.g. straw, flour, sawdust, organic waste, etc.).

## **D - VISIBILITY**

- The safety of people within the machine's working area, as well as that of the machine itself and the operator, are dependent on good operator visibility of the machine's immediate surroundings in all situations and at all times.
- This machine has been designed to allow good operator visibility (direct or indirect by means of rear view mirrors) of the immediate surroundings of the machine while driving unladen and with the lifting structure in the transport position.
- Special precautions must be taken if the size of the load restricts visibility towards the front:
  - moving in reverse,
  - site layout,
  - assisted by a person directing the operation (while standing outside the machine's area of travel), making sure to keep this person clearly in view at all times,
  - in any case, avoid reversing over long distances.
- Some attachments require the lifting structure to be raised in order to move the machine. In such cases, visibility on the right hand side is restricted, and special precautions must be taken:
  - site layout,
  - assisted by a person directing the operation (while standing outside the machine's area of travel).
  - replacement of a suspended load by a load on a pallet.
- If visibility of your road is inadequate, ask someone to assist by directing the operation (while standing outside the machine's area of travel), making sure to keep this person clearly in view at all times.
- Keep all components affecting visibility in a clean, properly adjusted state and in good working order (e.g. windshields, windows, windshield wipers, windshield washers, driving lights and worklights, rear-view mirrors).

## E - STARTING THE MACHINE

### SAFETY INSTRUCTIONS

#### **⚠ IMPORTANT ⚠**

*The machine must only be started up or maneuvered when the operator is sitting in the driver's cab with seat belt fastened and adjusted.*

- Never try to start the machine by pushing or pulling it. Such an operation may cause severe damage to the transmission. If necessary, towing requires the transmission to be put in neutral (↩ 3 - MAINTENANCE).
- If using an emergency battery for start-up, use a battery with the same characteristics and respect battery polarity when connecting it. Connect at first the positive terminals before the negative terminals.

#### **⚠ IMPORTANT ⚠**

*Failure to respect polarity between batteries can cause serious damage to the electrical circuit.*

*The electrolyte in the battery may produce an explosive gas. Avoid flames and generation of sparks close to the batteries.*

*Never disconnect a battery while it is in charge.*

### INSTRUCTIONS

- Check the closing and locking of the hood(s).
- Check that the cab door is closed.
- Firmly press and hold down the brake pedal.
- Turn the ignition key to position (I) to switch on the machine and the engine preheat system.
- Check that the forward/reverse selector is in neutral, and that the manual parking brake is on.
- Check the fuel level on the dashboard gauge.
- Check the DEF (diesel exhaust fluid) level on the dashboard gauge. (depending on machine model)
- Turn the ignition key to position (III) for no longer than 15 seconds. The engine should then start. Release the ignition key and let the engine run at idling speed.
- Preheat the engine between each start attempt.
- Make sure all the signal lights on the control instrument panel are off.
- Check the longitudinal stability limiter and warning device (↩ 3 - MAINTENANCE).
- Do not use a machine that is non-compliant.
- Check all control instruments when the engine is warm and at regular intervals during use, so as to quickly detect any faults and to be able to correct them without any delay.
- If an instrument does not show the correct display, stop the engine and immediately carry out the necessary operations.

## F - OPERATING THE MACHINE

### SAFETY INSTRUCTIONS

#### **⚠ IMPORTANT ⚠**

*We would like to draw the operators' attention to the risks involved in using the machine, in particular:*

*- Risk of losing control.*

*- Risk of loss of lateral and frontal stability of the machine.*

*The operator must remain in control of the machine.*

*In the event of the machine overturning, do not try to leave the cab during the incident.*

***YOUR BEST PROTECTION IS TO STAY FASTENED IN THE CAB.***

- Observe the company's traffic regulations or, by default, the public highway code.
- Do not carry out operations which exceed the capacities of your machine or attachment.
- Always drive the machine with the forks or attachment in the transport position, i.e., 300 mm from the ground, the telescopic arm retracted and the forks carriage sloping backward.
- Only carry loads which are balanced and properly anchored to avoid any risk of a load falling off.
- Ensure that pallets, cases, etc. are in good order and suitable for the load to be lifted.
- Familiarize yourself with the machine on the terrain where it will be used.
- Ensure that the brakes are working properly.
- The loaded machine must not travel at speeds in excess of 12 km/h.
- Drive smoothly at an appropriate speed for the operating conditions (land configuration, load on the machine).
- Do not use the hydraulic telescopic boom controls when the machine is moving.
- Never change the steering mode whilst driving.
- Ensure that visibility is adequate.
- Do not maneuver the machine with the lifting structure in the raised position unless under exceptional circumstances and then with extreme caution, at very low speed and using gentle braking.
- Take bends slowly.

- In all circumstances make sure you are in control of your speed.
- On damp, slippery or uneven terrain, drive slowly.
- Brake gently, never abruptly.
- Only use the machine's forward/reverse selector from a stationary position and never do so abruptly.
- Do not drive with your foot on the brake pedal.
- Always remember that hydrostatic type steering is extremely sensitive to movement of the steering wheel, so turn it gently and not jerkily.
- Never leave the engine on when the lift truck is unattended.
- Do not leave the cab when the machine has a raised load.
- Look where you are going and always make sure you have good visibility along the route.
- Use the rear-view mirrors frequently.
- Drive around obstacles.
- Never drive on the edge of a ditch or steep slope.
- It is dangerous to use two machines simultaneously to handle heavy or bulky loads, since this operation requires particular precautions to be taken. It must only be used exceptionally and after risk analysis.
- The ignition switch has an emergency stop mechanism in case of an operating anomaly occurring in the case of machines not fitted with a punch-operated cut-out.

## INSTRUCTIONS

- Always drive the machine with the forks or attachment in the transport position, i.e., 300 mm from the ground, the telescopic arm retracted and the forks carriage sloping backward.
- For machines with gearboxes, use the recommended gear (↩ 2 - DESCRIPTION: INSTRUMENTS AND CONTROLS).
- Select the steering mode appropriate for the use and/or working conditions (↩ 2 - DESCRIPTION: INSTRUMENTS AND CONTROLS) (depending on machine model).
- Deactivate the parking brake.
- Shift the forward/reverse selector to the selected direction of travel and accelerate gradually until the machine moves off.

### **⚠ IMPORTANT ⚠**

*Starting and moving the machine on a slope may be a real hazard.*

*If the machine is parked or stopped, adhere scrupulously to the following instructions for moving it:*

*- Press the brake pedal.*

*- Release the parking brake.*

*- Engage the appropriate gear. (depending on machine model)*

*- Select forward or reverse direction.*

*- Ensure that there is no one or anything impeding the movement of the machine.*

*- Release the brake pedal and accelerate the engine.*

*The use of the machine loaded or with a trailer increases the risk. In this case, remain extremely vigilant.*

*Each braking system operates independently.*

*In an emergency, use the brake pedal and/or the manual parking brake to immobilize the machine.*

*With the engine off, release the manual parking brake only after restarting the engine and making sure that the brake pedal is functional.*

## G - STOPPING THE MACHINE

### SAFETY INSTRUCTIONS

- Never leave the ignition key in the machine during the operator's absence.
- When the machine is stationary, or if the operator has to leave his cab (even for a moment), place the forks or attachment on the ground, apply the parking brake and place the forward/reverse selector in neutral.
- Make sure that the machine is not stopped in any position that will interfere with the traffic flow and at less than one meter from the track of a railway.
- In the event of prolonged parking on a site, protect the machine from bad weather, particularly from frost (check the level of antifreeze), and close and lock all the machine accesses (doors, windows, cowls, etc.).

### INSTRUCTIONS

- Park the machine on level ground.
- When parking on slopes of less than 15%, position the machine perpendicular to the slope.
- The slope must not exceed 15%.
- Press and hold the brake pedal.
- Set the forward/reverse selector to neutral.
- Activate the parking brake.
- Release the brake pedal.
- The machine must be stationary before leaving the driver's cab.
- Fully retract the telescopic arm.
- Lower the forks or attachment to rest on the ground.
- When using an attachment with a grab or jaws, or a bucket with hydraulic opening, close the attachment fully.
- Before stopping the machine after intensive work, leave the engine idling for a few moments to allow the coolant and oil to lower the temperature of the engine and transmission. Do not forget this precaution, in the event of frequent stops or warm stalling of the engine, or else the temperature of certain parts will rise significantly due to the stopping of the cooling system, with the risk of badly damaging such parts.
- Stop the engine with the ignition switch and remove the key.
- Lock all the openings to the machine (doors, windows, cowls, etc.).
- Turn the battery cut-off to the "OFF" position in accordance with the recommendations (↩ 2 - DESCRIPTION).

## H - DRIVING THE MACHINE ON THE PUBLIC HIGHWAY

(or see current legislation in other countries)

### FRENCH ROAD TRAFFIC RULES

- The driving of non-type-approved "Tractor" machines on the public highway is subject to the provisions of the French Highway Code relating to special machines, defined in Article R.311-1 of the French Highway Code, in category B of the Equipment Order of November 20, 1969, which determines the procedures applicable to special machines. The machine must be fitted with an operating license plate.
- The driving of type-approved "Tractor" machines on the public highway is subject to the provisions of the French Highway Code relating to agricultural tractors, defined in Article R.311-1 of the French Highway Code. The machine must be licensed.
- The machine must be driven on the public highway in accordance with the instructions given in the operator's manual supplied with the machine (Gross weight, Gross combination weight, towing load, axle loads, maximum speeds, etc. according to the type/version). The operator must be in possession of the machine's registration document.
- The operator must hold an HGV license, unless granted an exemption.
- When towing a trailer or agricultural equipment, the travel speed of the machine is limited to 25 km/h. In this case, a "25" disc must be affixed to the rear of the convoy.

### GERMAN ROAD TRAFFIC RULES

#### **⚠ IMPORTANT ⚠**

*For machines with the "Allgemeine Betriebserlaubnis" (general operating permit or ABE, in accordance with Article 20 of the StVZO "Straßenverkehrs-Zulassungsordnung"), follow the instructions below:*

- Disconnect the reversing sound alarm before using a machine with a general operating permit (ABE) on the public highway.

#### **⚠ IMPORTANT ⚠**

*Always reconnect the sound alarm before handling on private roads.*

- Before you use the machine for handling operations on private roads:
  - Make sure that the machine's reversing sound alarm is connected and working properly.
  - Perform a functional test by putting the machine into reverse gear.
  - The audible alarm sounds.
  - Do not use the machine if the audible alarm is not working. Check the audible alarm's connection and repeat the test. Consult your dealer if the problem persists.

### SAFETY INSTRUCTIONS

- Operators driving on the public highway must comply with current highway code legislation.
- The machine must comply with current road legislation. If necessary, there are optional solutions. Contact your dealer.

### INSTRUCTIONS

- Make sure the revolving light is in place, switch it on and verify its operation.
- Make sure the lights, turn signals and windshield wipers are working properly.
- Check the cleanliness of the machine's mudguards.
- Check the general cleanliness of the machine before driving on public roads.
- Switch off the worklights if the machine is fitted with them.
- Select the steering mode "HIGHWAY TRAFFIC" (↔ 2 - DESCRIPTION: INSTRUMENTS AND CONTROLS) (depending on machine model).
- Fully retract the telescopic arm and set the attachment approximately 300 mm off the ground.
- Put the frame leveling in the central position, i.e., the transverse axis of the axles parallel to the frame (depending on the machine model).
- Fully raise the stabilizers and turn the shoes inwards (depending on the machine model).

#### **⚠ IMPORTANT ⚠**

*Never coast in neutral (forward/reverse selector or gear lever in neutral or transmission cut-off button pressed) to preserve the machine's engine brake.*

*Failure to observe this instruction on a slope will lead to excessive speed, which may make the machine uncontrollable (steering, brakes) and cause serious mechanical damage.*

#### DRIVING THE MACHINE WITH A FRONT-MOUNTED ATTACHMENT

- You must comply with current regulations in your country, covering the possibility of driving on the public highway with a front-mounted attachment on your machine.
- If road legislation in your country authorizes circulation with a front-mounted attachment, you must at least:
  - Protect and report any sharp and/or dangerous edges on the attachment (↖ 4 - ADAPTABLE ATTACHMENTS AVAILABLE ON THE RANGE).
  - The attachment must not be loaded.
  - Make sure that the attachment does not mask the lighting range of the forward lights.
  - Make sure that current legislation in your country does not require other obligations.

#### OPERATING THE MACHINE WITH A TRAILER

- For using a trailer, observe the regulations in force in your country (maximum travel speed, braking, maximum weight of trailer, etc.).
- Do not forget to connect the trailer's electrical equipment to that of the machine.
- The trailer's braking system must comply with current legislation.
- If pulling a trailer with assisted braking, the tractor machine must be equipped with a trailer braking mechanism. In this case, do not forget to connect the trailer braking equipment to that of the machine.
- The vertical force on the towing hook must not exceed the maximum authorized by the manufacturer (consult the manufacturer's plate on your machine).
- The authorized gross vehicle weight must not exceed the maximum weight authorized by the manufacturer (↖ 2 - DESCRIPTION: SPECIFICATIONS).

**IF NECESSARY, CONSULT YOUR DEALER.**



## INSTRUCTIONS FOR HANDLING A LOAD

### A - CHOICE OF ATTACHMENTS

- Only attachments approved and authorized by MANITOU can be used on its machines.
- Make sure the attachment is suitable for the work to be done (↖ 4 - ADAPTABLE ATTACHMENTS AS OPTIONS ON THE RANGE).
- If the machine is equipped with the single sideshift attachment OPTION (TSDL), use only the authorized attachments (↖ 4 - ADAPTABLE ATTACHMENTS AS OPTIONS ON THE RANGE).
- Make sure the attachment is correctly installed and locked onto the machine carriage.
- Make sure that your machine attachments are working properly.
- Comply with the load chart limits for the machine for the attachment used.
- Do not exceed the rated capacity of the attachment.
- Never lift a slung load without the attachment provided for the purpose, as there is a risk of the sling slipping (↖ INSTRUCTIONS FOR HANDLING A LOAD: H - PICKING UP AND PUTTING DOWN A SUSPENDED LOAD).
- Do not handle loads suspended by straps directly on the forks (e.g. big bags), as there is a risk of shearing on sharp edges. Use an attachment designed for this purpose.

### B - WEIGHT OF LOAD AND CENTER OF GRAVITY

- Before picking up a load, you must know its weight and its center of gravity.
- The longitudinal position of the center of gravity in relation to the heel of the forks (Fig. B1) is defined on the load chart for your machine (↖ 2 - DESCRIPTION: DIMENSIONS AND LOAD CHARTS). For loads with center of gravity exceeding this distance, contact your dealer.
- For irregular loads, determine the transverse center of gravity before any handling (fig. B2) and set it in the longitudinal axis of the machine.

#### ⚠ IMPORTANT ⚠

*It is forbidden to handle a load heavier than the effective capacity defined on the machine load chart.*

*For loads with a moving center of gravity (e.g. liquids), take account of the variations in the center of gravity in order to determine the load to be handled and be extra vigilant and careful to limit these variations as far as possible.*



### C - LONGITUDINAL STABILITY LIMITER AND WARNING DEVICE

This device gives an indication of the longitudinal stability of the machine, and limits hydraulic movements in order to ensure this stability, at least under the following operating conditions:

- when the machine is at a standstill,
  - when the machine is on firm, stable and consolidated ground,
  - when the machine is performing handling and placing operations.
- Move the lifting structure very carefully when approaching the authorized load limit (↖ 2 - DESCRIPTION: INSTRUMENTS AND CONTROLS).
  - Always watch this device during handling operations.
  - If the "AGGRAVATING" hydraulic movements are cut off, perform only de-aggravating hydraulic movements in the following order (Fig. C): if necessary, raise the lifting structure (1), retract the telescopic boom as far as possible (2) and lower the lifting structure (3) to put down the load.

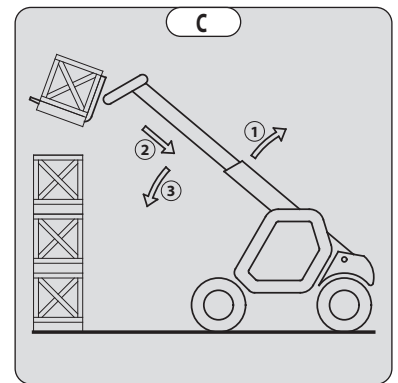

#### ⚠ IMPORTANT ⚠

*The instrument reading may be erroneous when the steering is at full lock or the rear axle is oscillated to its maximum extent.*

*Before lifting a load, ensure that the machine is not in any of these situations.*

## D - LATERAL TILTING OF THE MACHINE

Depending on machine model

Lateral tilting is the transverse slope of the chassis with respect to the horizontal. Raising the lifting structure reduces the machine's lateral stability. The machine's lateral tilting must be set with the lifting structure in the down position as follows:

### 1 - MACHINE WITHOUT FRAME LEVELING USED ON TIRES

- Position the machine so that the bubble in the level is between the two lines (↖ 2 - DESCRIPTION: INSTRUMENTS AND CONTROLS).

### 2 - MACHINE WITH FRAME LEVELING USED ON TIRES

- Correct the tilt using the hydraulic control and check the horizontality with the spirit level. The bubble of the level must be between the two lines (↖ 2 - DESCRIPTION: INSTRUMENTS AND CONTROLS).

### 3 - MACHINE USED ON STABILIZERS

- Set the two stabilizers on the ground and raise the two front wheels of the machine (fig. D1).
- Correct the tilt using the stabilizers (Fig. D2) and check the horizontality with the spirit level. The bubble of the level must be between the two lines (↖ 2 - DESCRIPTION: INSTRUMENTS AND CONTROLS). In this position, the two front wheels must be off the ground.

## E - PICKING UP A LOAD ON THE GROUND

- Approach the machine perpendicular to the load, with the telescopic boom retracted and the forks in a horizontal position (fig. E1).
- Adjust the fork spacing and centering relative to the load to ensure stability (Fig. E2) (optional solutions exist, consult your dealer).
- Never lift a load with a single fork.

### ⚠ IMPORTANT ⚠

*Beware of the risks of trapping or squashing limbs when manually adjusting the forks.*

- Move the machine forward slowly (1) and bring the forks up to the stop in front of the load (fig. E3). If necessary, raise the lifting structure (2) slightly while picking up the load.
- Position the load in the transport position.
- Tilt the load far enough backward to ensure stability (loss of load on braking or going downhill).

### FOR A NON-PALLETIZED LOAD

- Tilt the carriage (1) forward and move the machine slowly forward (2) to position the fork under the load (fig. E4) (chock the load if necessary).
- Continue to move the machine (2) forward, tilting the carriage (3) (fig. E4) backward to position the load on the forks and check the load's longitudinal and lateral stability.

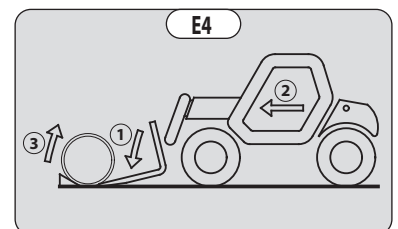
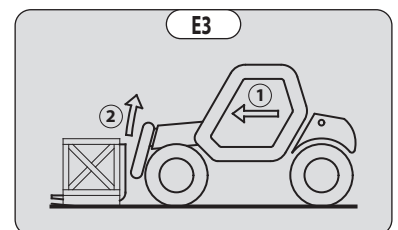
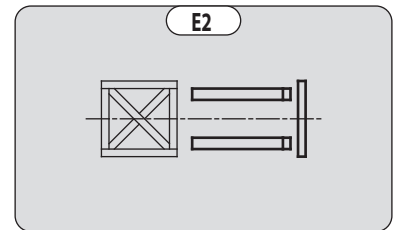
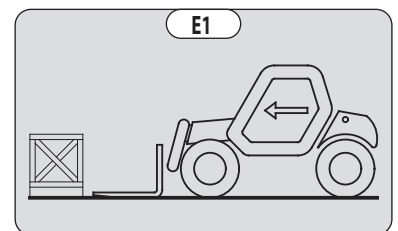
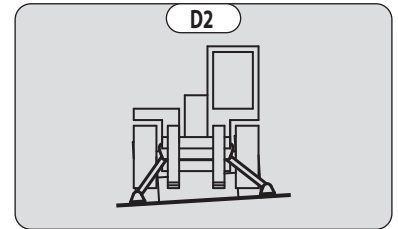
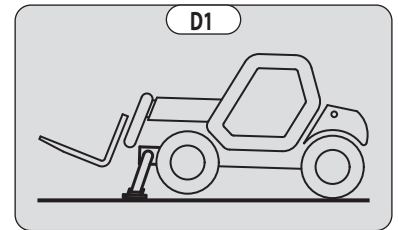

## F - PICKING UP AND PUTTING DOWN A HIGH LOAD ON TIRES

### ⚠ IMPORTANT ⚠

*You must not raise the lifting structure if you have not checked the lateral tilting of the machine (← INSTRUCTIONS FOR HANDLING A LOAD: D - LATERAL TILTING OF THE MACHINE).*

REMINDER: Make sure that the following operations can be performed with good visibility (← OPERATING INSTRUCTIONS UNLADEN AND LADEN: D - VISIBILITY).

### PICKING UP A HIGH LOAD ON TIRES

- Ensure that the forks will easily pass under the load.
- Raise and extend the telescopic boom (1) (2) until the forks are level with the load. If necessary, move the machine (3) forward (fig. F1), driving very slowly and carefully.
- Always remember to keep the distance necessary for inserting the forks under the load, between the stack and the machine (fig. F1) and use the shortest possible length of lifting structure.
- Bring the forks up to the front of the load by alternately extending and lowering the telescopic boom (1) or, if necessary, by moving the machine forward (2). Activate the parking brake and place the forward/reverse selector in neutral.
- Lift the load slightly (1) and tilt the carriage (2) backwards to stabilize the load (Fig. F3).
- Tilt the load sufficiently backward to ensure its stability.
- Monitor the longitudinal stability limiter and warning device (← INSTRUCTIONS FOR HANDLING A LOAD: C - LONGITUDINAL STABILITY LIMITER AND WARNING DEVICE). If it is overloaded, set the load back down in the place from which it was picked up.
- If possible, lower the load without moving the machine. Raise the lifting structure (1) to release the load, retract (2) and lower the lifting structure (3) to put the load into the transport position (fig. F4).
- If this is not possible, reverse the machine (1), maneuvering very gently and carefully to release the load. Retract (2) and lower the lifting structure (3) to bring the load into the transport position (fig. F5).

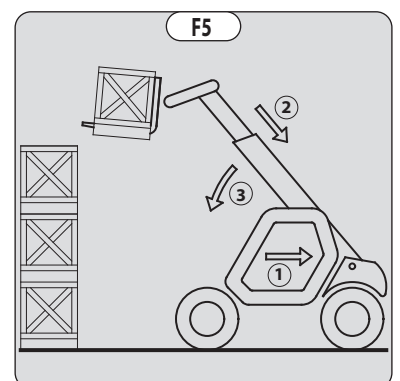
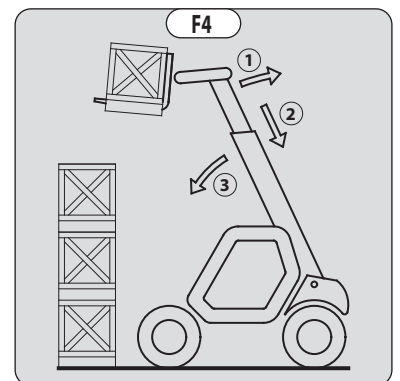
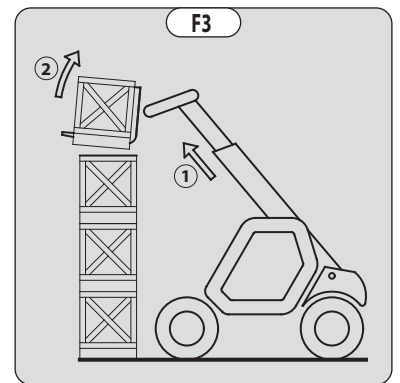
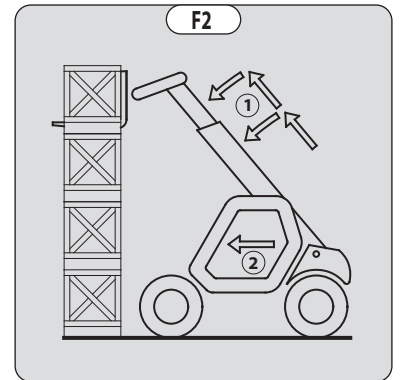
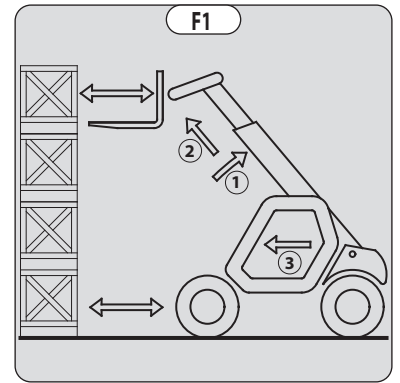

## PUTTING DOWN A HIGH LOAD ON TIRES

- Approach the load in the transport position in front of the stack (Fig. F6).
- Activate the parking brake and place the forward/reverse selector in neutral.
- Raise and extend the telescopic boom (1) (2) until the load is above the stack, while monitoring the longitudinal stability limiter and warning device (← INSTRUCTIONS FOR HANDLING A LOAD: C - LONGITUDINAL STABILITY LIMITER AND WARNING DEVICE). If necessary, move the machine (3) forward (fig. F7), driving very slowly and carefully.
- Place the load in a horizontal position and put it down on the pile by lowering and retracting the telescopic boom (1) (2) in order to position the load correctly (fig. F8).
- If possible, release the forks by alternately retracting and raising the telescopic boom (1) (fig. F9). Then set the forks in the transport position.
- If this is not possible, reverse the machine (1), maneuvering very slowly and carefully to release the forks (fig. F10). Then set the forks in the transport position.

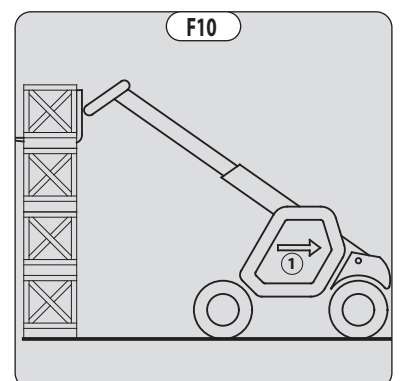
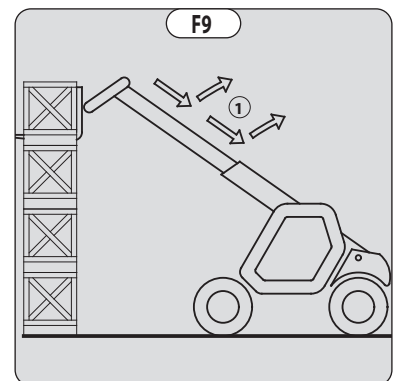
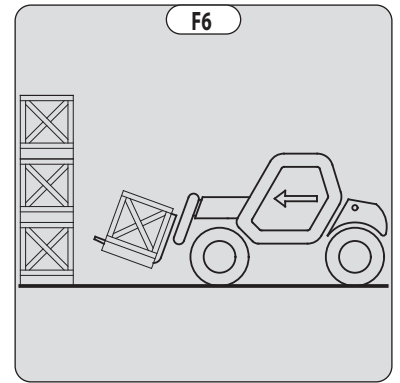

## G - PICKING UP AND PUTTING DOWN A HIGH LOAD ON STABILIZERS

Depending on machine model

### **⚠ IMPORTANT ⚠**

**You must not raise the lifting structure if you have not checked the lateral tilting of the machine (← INSTRUCTIONS FOR HANDLING A LOAD: D - LATERAL TILTING OF THE MACHINE).**

REMINDER: Make sure that the following operations can be performed with good visibility (← OPERATING INSTRUCTIONS UNLADEN AND LADEN: D - VISIBILITY).

The stabilizers are used to optimize the machine's lifting performance (← 2 - DESCRIPTION: INSTRUMENTS AND CONTROLS).

POSITIONING THE STABILIZERS WITH THE FORKS IN TRANSPORT POSITION (UNLADEN AND LADEN)

- Set the forks in the transport position in front of the elevation.
- Stay far enough away to allow the telescopic boom to be raised.
- Activate the parking brake and place the forward/reverse selector in neutral.
- Set the two stabilizers on the ground and lift the two front wheels of the machine (fig. G1), while maintaining its lateral tilting.

RAISING THE STABILIZERS WITH THE FORKS IN TRANSPORT POSITION (UNLADEN AND LADEN)

- Raise both stabilizers fully and at the same time.

LOWERING THE STABILIZERS WITH LIFTING STRUCTURE UP (UNLADEN AND LADEN)

### **⚠ IMPORTANT ⚠**

***This operation must be exceptional and performed with great care.***

- Raise the lifting structure and fully retract the telescopic boom.
- Set the machine in position in front of the elevation (fig. G2), moving very slowly and carefully.
- Activate the parking brake and place the forward/reverse selector in neutral.
- Move the stabilizers very slowly and gradually as soon as they are close to the ground or in contact with it.
- Lower the two stabilizers and lift the two front wheels of the machine (fig. G3). During this operation, lateral tilting must be permanently maintained: the bubble in the level must be kept between the two lines.

LIFTING THE STABILIZERS WITH THE LIFTING STRUCTURE UP (UNLADEN AND LADEN)

### **⚠ IMPORTANT ⚠**

***This operation must be exceptional and performed with great care.***

- Keep the lifting structure raised and retract the telescopic booms completely (fig. G3).
- Move the stabilizers very slowly and gradually as soon as they are in contact with the ground and when they leave the ground. During this operation, lateral tilting must be permanently maintained: the bubble in the level must be kept between the two lines.
- Raise both stabilizers completely.
- Deactivate the parking brake and reverse the machine (1) very slowly and carefully to release it and lower the forks (2) into transport position (fig. G4).

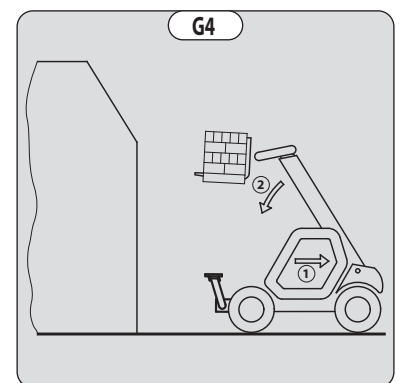
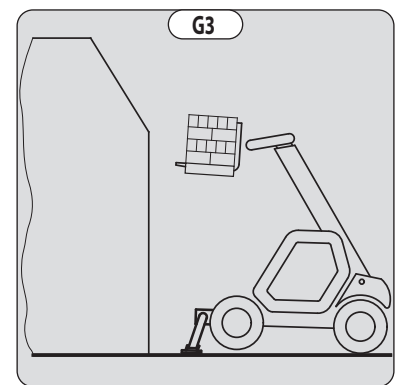
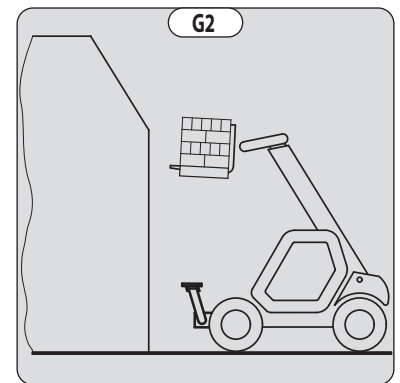
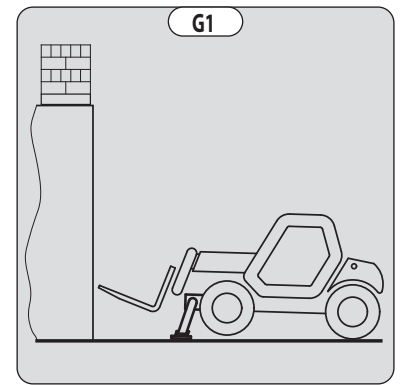

## PICKING UP A HIGH LOAD ON STABILIZERS

- Ensure that the forks will easily pass under the load.
- Check the position of the machine with respect to the load and make a test run, if necessary, without picking up the load.
- Raise and extend the telescopic boom (1) (2) until the forks are level with the load (fig. G5).
- Bring the forks to the stop in front of the load by alternately extending and lowering the telescopic boom (1) (fig. G6).
- Lift the load slightly (1) and tilt the carriage (2) backwards to stabilize the load (Fig. G7).
- Monitor the longitudinal stability limiter and warning device (← INSTRUCTIONS FOR HANDLING A LOAD: C - LONGITUDINAL STABILITY LIMITER AND WARNING DEVICE). If it is overloaded, set the load back down in the place from which it was picked up.
- If possible, lower the load without moving the machine. Raise the lifting structure (1) to release the load, retract (2) and lower the lifting structure (3) to put the load into the transport position (fig. G8).

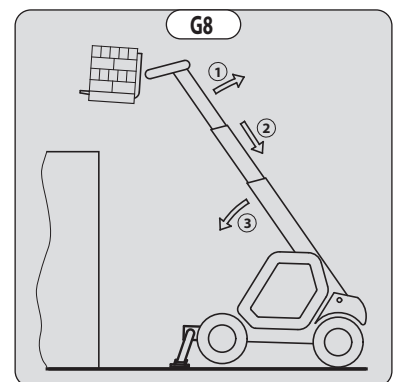
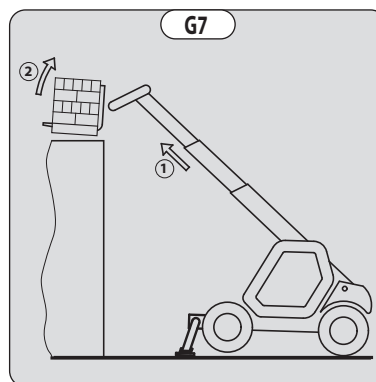
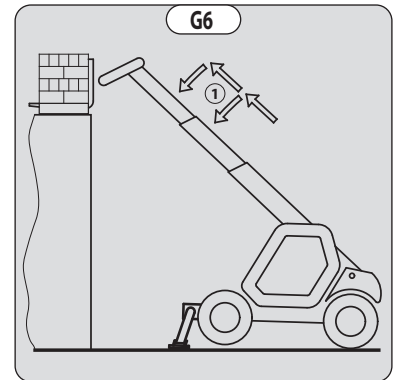
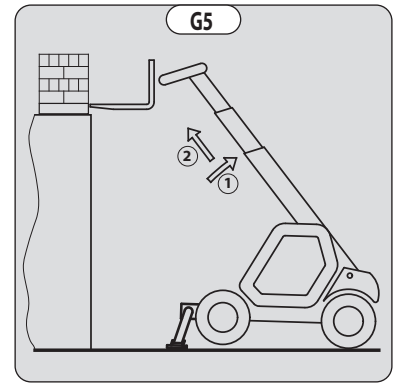

## SETTING DOWN A HIGH LOAD ON STABILIZERS

- Raise and extend the telescopic boom (1) (2) until the load is above the elevation (fig. G9), while monitoring the longitudinal stability limiter and warning device (← INSTRUCTIONS FOR HANDLING A LOAD: C - LONGITUDINAL STABILITY LIMITER AND WARNING DEVICE).
- Position the load horizontally and set it down by lowering and retracting the telescopic boom (1) (2) to position the load correctly (fig. G10).
- Free the forks by alternately retracting and raising the telescopic boom (3) (fig. G11).
- If possible, set the lifting structure in the transport position without moving the machine.

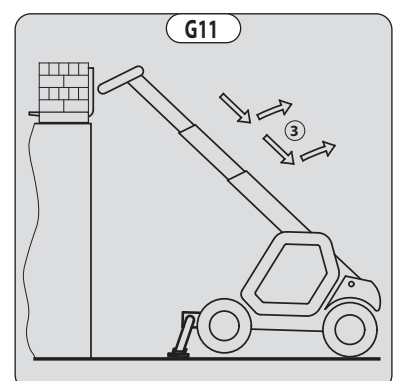
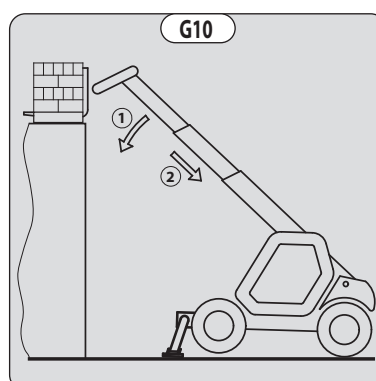
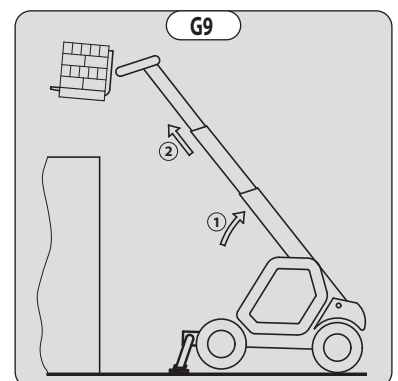

## H - PICKING UP AND PUTTING DOWN A SUSPENDED LOAD

### **⚠ IMPORTANT ⚠**

*Failure to follow the above instructions may lead the machine to lose stability and overturn.*

*MUST be used with a machine equipped with an operational hydraulic movement cut-off device.*

#### CONDITIONS OF USE

- The length of the sling or the chain shall be as short as possible to limit swinging of the load.
- Lift the load vertically along its axis, never by pulling sideways or lengthways.

#### HANDLING WITHOUT MOVING THE MACHINE

- Whether on stabilizers or on tires, the lateral attitude must not exceed 1% and the longitudinal attitude must not exceed 5%: the bubble of the level must be held at "0".
- Ensure that the wind speed is not higher than 10 m/s.
- Ensure that there is no one between the load and the machine.

#### I - TRAVELING WITH A SUSPENDED LOAD

- Before moving, inspect the terrain in order to avoid excessive slopes and cross-falls, bumps and potholes, or soft ground.
- Ensure that the wind speed is not higher than 36 km/h.
- The machine must not travel at more than 0.4 m/s (1.4 km/h, i.e. one quarter walking speed).
- Drive and stop the machine gently and smoothly to minimize swinging of the load.
- Carry the load a few centimeters above the ground (max. 30 cm) with the shortest possible length. Do not exceed the offset indicated on the load chart. If the load begins to swing excessively, do not hesitate to stop and lower the lifting structure to set down the load.
- Before moving the machine, check the longitudinal stability limiter and warning device (☞ 2 - DESCRIPTION: INSTRUMENTS AND CONTROLS), only the green LEDs and possible the yellow LEDs should be lit
- During transport, the lift truck operator must be assisted by a person on the ground (standing a minimum of 3 m from the load), who will limit swinging of the load using a bar or a rope. Ensure that this person is always clearly in view.
- Lateral tilting must not exceed 5% and the bubble in the level must be kept between the two "MAX" marks.
- Longitudinal tilting must not exceed 15% with the load facing uphill and 10% with the load facing downhill.
- The telescopic boom angle must not exceed 45°.
- If the first red LED of the longitudinal stability limiter and warning device (☞ 2 - DESCRIPTION: INSTRUMENTS AND CONTROLS) comes on while traveling, gently bring the machine to a halt and stabilize the load. Retract the telescopic arm to reduce the offset of the load.

## INSTRUCTIONS FOR USE AS A LOADER

For agricultural-type machines (MLT range)

### A - LOADING

#### ⚠ IMPORTANT ⚠

*You must not raise the lifting structure if you have not checked the lateral tilting of the machine (← INSTRUCTIONS FOR HANDLING A LOAD: D - LATERAL TILTING OF THE MACHINE).*

REMINDER: Make sure that the following operations can be performed with good visibility (← OPERATING INSTRUCTIONS UNLADEN AND LADEN: D - VISIBILITY).

#### FILLING THE BUCKET

- Place the bottom of the bucket in a horizontal position, just in contact with the ground (1) (Fig. A1).
- Move forward gradually (2) while simultaneously raising the lifting structure and tilting the bucket backward (3), for improved filling and breakout (fig. A1).
- Reverse the machine (1) very carefully and gently to free the bucket. Lower the lifting structure (2) into the transport position (fig. A2).

#### ⚠ IMPORTANT ⚠

*Tilt the bucket sufficiently back to avoid spilling product and ensure its stability (loss of product under braking).*

#### LOADING A TRAILER

- Approach the side of the trailer in the transport position (Fig. A3).
- Raise and extend the telescopic boom (1) (2) until the bucket is above the trailer, while monitoring the longitudinal stability limiter and warning device (← INSTRUCTIONS FOR HANDLING A LOAD: C - LONGITUDINAL STABILITY LIMITER AND WARNING DEVICE) (Fig. A4).
- Drive the machine forward (3) very carefully and gently so that the bucket empties its load in the center of the trailer (Fig. A4).
- Immobilize the machine with the brake pedal and put the reversing shift lever in neutral.

N.B.: Immobilizing the machine with the brake pedal means that the transmission should be in neutral. Failure to follow this recommendation may lead to overheating and damage to the brakes.

- Slowly discharge the product (4) (Fig. A4).
- Tilt the bucket backwards (1) and reverse the machine (2) very carefully and gently (Fig. A5).
- Retract (3) and lower the lifting structure (4) into the transport position (fig. A5).

### B - BACKFILLING

- Place the bottom of the bucket in a horizontal position, just in contact with the ground (1) (Fig. B1).
- Drive forward gradually (2). Once filled, the bucket will act as a leveling blade (Fig. B1).

#### ⚠ IMPORTANT ⚠

*When driving, beware of trenches as well as recently excavated and/or backfilled ground.*

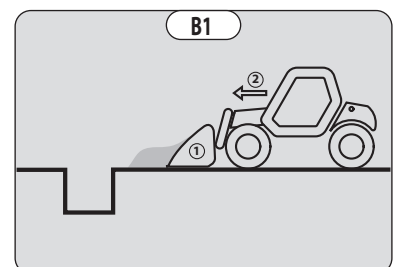
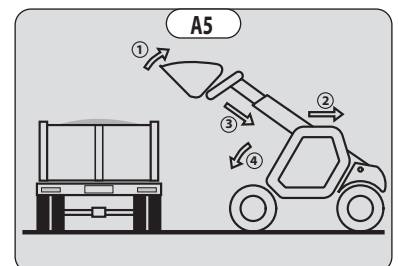
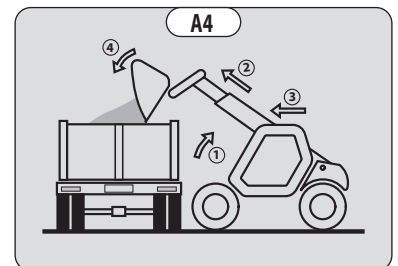
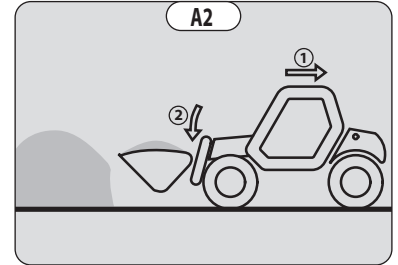
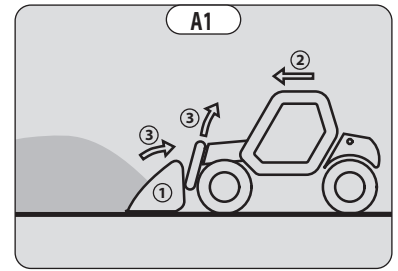

## OPERATING INSTRUCTIONS FOR MACHINE WITH PLATFORM

For machines equipped with a MEWP (Mobile Elevating Work Platform)

### A - AUTHORIZATION TO OPERATE THE MACHINE WITH PLATFORM

- Operation of the platform requires further authorization in addition to that of the machine.

### B - SUITABILITY OF THE MACHINE FOR PLATFORM USE

- Our machines fitted with mobile elevating work platforms are compliant with standard **EN 280-1** for Europe and standard **AS/NZS 1418.10:2011** for Australia, corresponding to the classification of Group C1 to C3 in accordance with this standard.
- MANITOU has ensured that this machine equipped with a platform is suitable for use under the normal operating conditions provided in this operator's manual, with a STATIC TEST COEFFICIENT OF 1.25 and a DYNAMIC TEST COEFFICIENT OF 1.1 as specified in harmonized European standard **EN 280-1** for machines equipped with a mobile elevating work platform.
- Before commissioning, the company manager must make sure that the machine equipped with a platform is appropriate for the work to be done, and perform certain tests (in accordance with current legislation).

### C - PROVIDED ON THE PLATFORM

- Wear suitable clothing when using the platform, avoid loose-fitting garments.
- Never use the platform with hands or shoes that are wet or soiled with greasy substances.
- Remain alert at all times when using the platform. Do not listen to the radio or music using headphones or earphones.
- MANITOU strongly recommends wearing a safety harness attached to an attachment point in the platform. Wearing a safety harness or other personal protection equipment against falls may be compulsory. Comply with local, government and national regulations in force, employer's safety rules and work site regulations .
- The safety harness or other personal protection equipment against falls must comply with local, government, and national regulations in force. They must be inspected in accordance with the regulations in force.
- The control units must never be used for any other than their intended purposes (e.g. Climbing onto or down from the machine, coat hanger, etc.).
- Safety helmets must be worn.
- Make sure you have the appropriate protective equipment for the job to be done.
- Prolonged exposure to high noise levels may cause hearing problems. It is recommended to wear ear muffs to protect against excessive noise.
- The operator must always be in his normal position in the driver's cab: it is prohibited to have arms or legs, or generally any part of the body, outside the platform.
- Ensure that materials loaded onto the platform (pipes, cables, containers, etc.) cannot fall out. Do not pile these materials to the point where it is necessary to step over them.

### D - USING THE PLATFORM

- However experienced they may be, operators must acquaint themselves with the emplacement and operation of all control instruments prior to operating the platform.
- Check before use that the platform has been correctly assembled and locked onto the machine.
- Do not enter or exit the platform unless it is fully lowered.
- Always enter and exit the platform through the gate or using the sliding mid rails (depending on the model).
- Always enter and exit facing the interior of the platform.
- Always use 3 support points, either both hands and one foot or both feet and one hand, to get in and out of the platform.
- Make sure that the sliding intermediate cross members (depending on the model) are in the lower position and that the gate is properly closed (depending on the model) before using this platform.
- Do not attach the sliding mid rails in the high position.
- The platform should be operated in an area free of any obstructions or danger when it is lowered to the ground.
- The operator using the platform must be aided by someone on the ground with adequate training.
- Comply with the load chart for machines equipped with a mobile elevating work platform (MEWP).
- The lateral constraints are limited (↩ 2 - DESCRIPTION: SPECIFICATIONS).
- It is strictly forbidden to suspend a load from the platform or the machine's lifting structure without an attachment provided for the purpose (↩ INSTRUCTIONS FOR HANDLING A LOAD: H - PICKING UP AND PUTTING DOWN A SUSPENDED LOAD).
- The platform cannot be used as a crane or a lift for permanently transporting people or materials, nor as jacks or supports.

- The machine must not be moved with one (or more) person(s) on the platform.
- It is forbidden to transport people on the platform using the hydraulic controls in the machine's cab (except in case of rescue).
- The operator must not climb onto or off the platform when it is not at ground level (lifting structure retracted and in the down position).
- The machine must not be fitted with unauthorized attachments that increase the windage of the assembly.
- Do not use ladders or improvised structures on the platform to gain extra height.
- Do not climb onto the rails of the platform to gain extra height.
- It is forbidden to use the platform on forks. The fork slots are only to be used for storing the platform and not for lifting people under any circumstances.

## E - ENVIRONMENT

### ⚠ IMPORTANT ⚠

*If the platform must remain stationary over a structure for a long period, there is a risk that the platform will lower and rest on this structure due to the oil cooling in the cylinders or a minor leak in the cylinder locking system. To eliminate this risk:*

- *regularly check the distance between the platform and the structure, readjust if necessary,*
- *if possible, use the machine at an oil temperature as close as possible to ambient temperature.*

### ⚠ IMPORTANT ⚠

*Operating the machine close to power lines is forbidden. Respect the safety distances.*

*You must consult your local electrical supplier.*

*You could be electrocuted or seriously injured if you operate or park the machine too close to power lines.*

*If the machine is in contact with power lines, push in the emergency stop button.*

*Call for help, warn people on the ground not to touch the machine, and ask them to switch off the power supply to the cables or have it switched off.*

### ⚠ IMPORTANT ⚠

*Do not operate this machine during thunderstorms, snowstorms, periods of frost, or in hazardous weather conditions. In the event of strong wind exceeding 45 km/h, do not make any movements which can compromise the machine stability.*

- Respect a safety distance between power lines or live components and any part of the body, any conductive object or any part of the machine, unless the local, government and national applicable regulations, the safety rules of the employer or construction site regulations are more strict in terms of distance required.
- Allow for platform movement and swaying or sagging power lines.

### ⚠ IMPORTANT ⚠

*It is forbidden to use the platform close to electricity cables. Maintain the specified safe distances.*

RATED VOLTAGE (VOLTS)	SAFETY DISTANCE (METERS)
50 < U < 1000	2,30 M
1000 < U < 30000	2,50 M
30000 < U < 45000	2,60 M
45000 < U < 63000	2,80 M
63000 < U < 90000	3,00 M
90000 < U < 150000	3,40 M
150000 < U < 225000	4,00 M
225000 < U < 400000	5,30 M
400000 < U < 750000	7,90 M

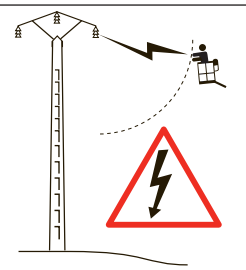

**⚠ IMPORTANT ⚠**

*It is strictly forbidden to use the platform when the wind speed exceeds 45 km/h.*

- To visually recognize this wind speed, refer to the empirical wind evaluation scale below:

BEAUFORT scale (wind speed at a height of 10 m on a flat site)						
Force	Type of wind	Speed (knots)	Speed (km/h)	Speed (m/s)	Effects on Land	Sea conditions
0	Calm	0 - 1	0 - 1	< 0.3	Smoke rises vertically.	Sea is like a mirror.
1	Light air	1 - 3	1 - 5	0.3 - 1.5	Smoke indicates direction of wind.	Ripples with appearance of scale, no foam crests.
2	Light breeze	4 - 6	6 - 11	1.6 - 3.3	Wind felt on face, leaves rustle.	Short wavelets, but pronounced.
3	Gentle breeze	7 - 10	12 - 19	3.4 - 5.4	Leaves and small twigs in constant motion.	Very small waves, crests begin to break.
4	Moderate breeze	11 - 16	20 - 28	5.5 - 7.9	Wind raises dust and loose pieces of paper; small branches are moved.	Small waves, becoming longer, numerous whitecaps.
5	Fresh breeze	17 - 21	29 - 38	8 - 10.7	Small trees in leaf begin to sway.	Wavelets form on inland waters; moderate waves, taking longer form.
6	Strong breeze	22 - 27	39 - 49	10.8 - 13.8	Large branches in motion, whistling heard in overhead wires, umbrella use becomes difficult.	Larger waves forming, whitecaps everywhere, some spray.
7	Near gale	28 - 33	50 - 61	13.9 - 17.1	Whole trees in motion, inconvenience felt when walking against the wind.	Sea heaps up; white foam from breaking waves begins to be blown in streaks along the direction of the wind.
8	Gale	34 - 40	62 - 74	17.2 - 20.7	Wind breaks twigs off trees; impedes progress.	Moderately high waves of greater length; edges of crests begin to break into spindrift.
9	Strong gale	41 - 47	75 - 88	20.8 - 24.4	Wind damages roofs (chimneys, slates, etc.).	High waves, crests of waves begin to topple, streaks of foam; reduced visibility.
10	Storm	48 - 55	89 - 102	24.5 - 28.4	Seldom experienced inland; trees uprooted; considerable structural damage occurs.	Very high waves; white streaks of foam; reduced visibility.
11	Violent storm	56 - 63	103 - 117	28.5 - 32.6	Very rare, widespread damage.	Exceptionally high waves able to hide medium sized ships from view, reduced visibility.
12	Hurricane	64 +	118 +	32.7 +	Devastating damage.	Sea completely white; air filled with foam and spray, very reduced visibility.

**F - MAINTENANCE**

**⚠ IMPORTANT ⚠**

*Your platform must be periodically inspected to ensure its continued compliance.*

*The frequency of this inspection is defined by the legislation in force in the country in which the platform is used.*

*In France, a general periodic inspection every 6 months (Decree of March 1, 2004).*

## INSTRUCTIONS FOR USING THE RADIO-CONTROL

For machines with RC radio control

### HOW TO USE THE RADIO-CONTROL

#### SAFETY INSTRUCTIONS

#### **⚠ IMPORTANT ⚠**

*It is prohibited to lift people in the platform using the radio-control.*

*It is prohibited to use the radio-control from the platform:*

- This radio-control consists of electronic and mechanical safety elements. It cannot receive commands from another transmitter because the internal encoding is unique to each radio-control.

#### **⚠ IMPORTANT ⚠**

*If it is used improperly or incorrectly, there is a risk of danger to:*

- *The physical and mental health of the user or others.*
- *The machine and other neighboring items.*

*Everyone working with this radio-control:*

- *Must be qualified in line with current regulations and trained accordingly.*
- *Must follow this operator's manual as closely as possible.*

- The system is used to control the machine remotely via radio waves. Commands are also transmitted if the machine is out of sight (behind an obstacle or a building for example), this is why:
  - After stopping the truck and removing the key switch (only possible when it is stationary), always place the transmitter in a safe, dry place.
  - Before performing any installation, servicing or repair work, always switch off power sources (in particular, electric welding devices and electric head units on hydraulic distributors must be disconnected at each section).
  - Never remove or alter the safety devices (such as the hand-guard frame, key, emergency stop button, etc.).

#### **⚠ IMPORTANT ⚠**

*Never operate the machine if it is not continuously and perfectly within view of the operator.*

- Before leaving the transmitter, the operator must make sure that it cannot be used by an unauthorized third person: either by removing the key button from the transmitter or locking it in an inaccessible place.
- The user must ensure that the operator's manual is accessible at all times and that operators have read and understood it.

#### INSTRUCTIONS

- Take up position in a stable place with no risk of slipping.
- Before using the transmitter, make sure there is nobody within the working area.
- Only use the transmitter with its carrying device or installed correctly on the platform.

#### **⚠ IMPORTANT ⚠**

*When you remove the transmitter, remove the battery and the key button so that it cannot be used accidentally or deliberately by anyone else.*

#### SAFETY DEVICES

- The machine will be immobilized within a maximum of 450 milliseconds (approx. 0.5 second):
  - If the emergency stop button of the transmitter is pressed (50 milliseconds), or that of the machine.
  - If the transmission distance of the radio waves is exceeded.
  - If the transmitter is faulty.
  - If an interfering radio signal is received from elsewhere.
  - If the battery is removed from its housing in the transmitter.
  - If the battery has no more charge.
  - If the transmitter is switched off by turning the key switch to the off position.
- These protective devices are provided for the safety of personnel and property and must never be modified, removed or bypassed in any way whatsoever!
- The hand-guard frame prevents external action on a joystick (e.g. if the transmitter is dropped, or if the operator leans on a guard-rail).
- An electronic safety device prevents radio transmission from being initiated if the joysticks are not mechanically and electrically at rest and if the internal combustion engine speed selector is not set to idle.

#### **⚠ IMPORTANT ⚠**

*In an emergency, press the transmitter emergency stop button immediately, then follow the instructions in the operator's manual (↩ 2 - DESCRIPTION: INSTRUMENTS AND CONTROLS).*

# MACHINE MAINTENANCE INSTRUCTIONS

## GENERAL INSTRUCTIONS

### ⚠ IMPORTANT ⚠

Carefully read and understand this operator's manual before doing any work on this machine.

Carry out all repairs immediately, even if the repairs concerned are minor.

Repair all leaks immediately, even if the leak concerned is minor.

Be careful of the risk of burns and splashing (exhaust, radiator, engine, hydraulic oil, etc.).

- Make sure the area is adequately ventilated before starting up the machine.
- Wear clothes suitable for the maintenance of the machine. Avoid wearing jewelry and loose clothes. Tie back and protect your hair, if necessary.
- Stop the engine and remove the ignition key before carrying out any work.

## PLACING THE LIFTING STRUCTURE SAFETY WEDGE

- The machine is equipped with a lifting structure safety wedge (⚠ 2 - DESCRIPTION: INSTRUMENTS AND CONTROLS) that must be installed on the lifting cylinder rod when working beneath the lifting structure.
- Telescopic arm retracted without forks or attachments.

ACCORDING TO INSTALLATION

### FITTING THE WEDGE

- Raise the lifting structure all the way up.
- Place the safety wedge 1 on the rod of the lifting cylinder and secure with the rod 2 and the pin 3.
- Slowly lower the lifting structure, then stop the hydraulic movements before it comes into contact with the wedge.

### REMOVING THE WEDGE

- Raise the lifting structure all the way up.
- Remove the pin and the rod.
- Return the safety wedge to the storage location provided on the machine.

### ⚠ IMPORTANT ⚠

Only use the wedge supplied with the machine.

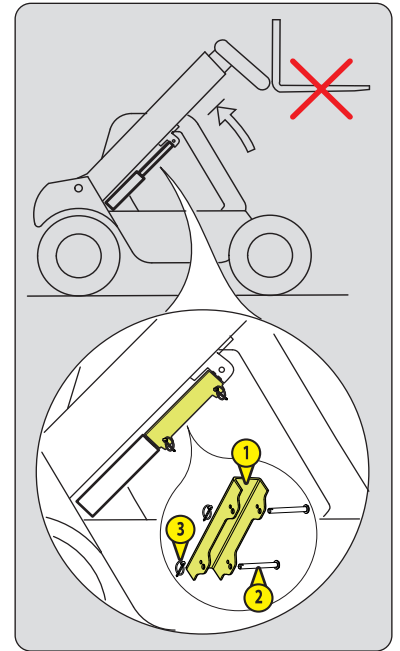

ACCORDING TO INSTALLATION

### FITTING THE WEDGE

- Raise the lifting structure all the way up.
- Loosen the thumbwheels 1.
- Assemble the parts of the safety wedge 2 around the cylinder rod and lock with the pins 3.

NOTE: the stop flats 4 of the safety wedge must be located towards the bottom of the lifting cylinder 5.

- Slowly lower the lifting structure, then stop the hydraulic movements before it comes into contact with the wedge.

### REMOVING THE WEDGE

- Raise the lifting structure all the way up.
- Remove the pins 3.
- Put the parts of the safety wedge 2 back on the machine and lock them with the thumbwheels 1.
- Replace the pins 3 on the parts of the safety wedge.

### ⚠ IMPORTANT ⚠

Only use the wedge supplied with the machine.

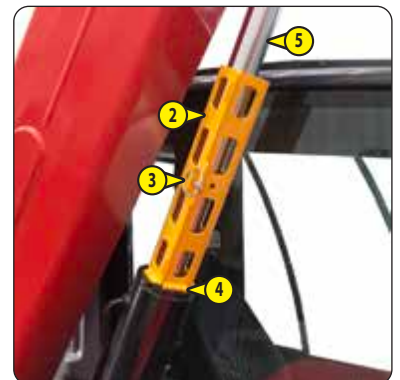
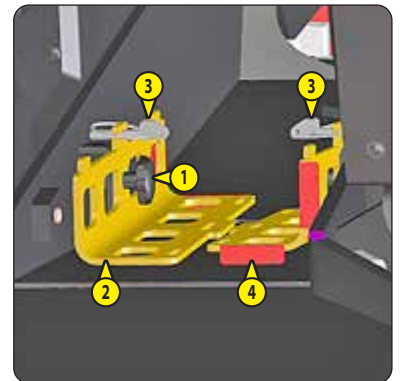

## MAINTENANCE

---

- Perform the periodic service (↩ 3 - MAINTENANCE) to keep your machine in good working order. Failure to perform periodic maintenance may invalidate the contractual warranty.

### MAINTENANCE LOGBOOK

- The maintenance operations carried out in accordance with the recommendations given in section 3 - MAINTENANCE and the other inspection, servicing or repair operations or modifications performed on the machine shall be recorded in a maintenance logbook.
- The entry for each operation should include the date of the work, the names of the individuals or companies having performed them, the type of operation and its frequency, if applicable.
- If machine elements are replaced, the part numbers of these elements shall be indicated.

## LUBRICANT AND FUEL LEVELS

---

- Use the recommended lubricants (never use contaminated lubricants).
- Do not fill the fuel tank when the engine is running.
- Only fill up the fuel tank in areas specified for this purpose.
- Do not fill the fuel tank to the maximum level.
- Do not smoke or approach the machine with a flame when the fuel tank is open or is being filled.

## HYDRAULICS

---

- Any work on the load handling hydraulic circuit is forbidden except for the operations described in chapter: 3 - MAINTENANCE.
- Do not attempt to loosen unions, hoses or any hydraulic component with the circuit under pressure.



**COUNTERBALANCE VALVE:** *it is dangerous to change the setting or remove the counterbalance valves or safety valves which may be fitted to the cylinders of your machine.*

**HYDRAULIC ACCUMULATOR:** *dismantling hydraulic accumulators and their pipes which may be fitted on your machine is dangerous. Such operations must only be performed by approved personnel (consult your dealer).*

## ELECTRICITY

---

- Do not short-circuit the starter relay to start the engine. If the forward/reverse selector is not in neutral and the parking brake is not on, the machine may suddenly start to move.
- Do not place metal items on the battery.
- Disconnect the battery before working on the electrical circuit.

## WELDING ON THE MACHINE

---



**Welding operations on the machine for the purposes of maintenance or repairs must only be carried out by people authorized by MANITOU.**

- Disconnect the battery before any welding operations on the machine.
- When carrying out electric welding work on the machine, connect the negative cable from the equipment directly to the part being welded so as to avoid very high current passing through the alternator.
- Never carry out welding or work which gives off heat on an assembled tire. The heat would increase the pressure which could cause the tire to explode.
- If the machine is equipped with an electronic control unit, disconnect it before starting to weld so as to avoid the risk of causing irreparable damage to electronic components.

## WASHING THE MACHINE

---

### ⚠ IMPORTANT ⚠

*When washing with a high pressure cleaner, avoid the engine air intakes, the cylinder rod wiper seals, the hinges, the structural components and the electrical connections, etc.*

- Clean the machine or at least the area concerned before any intervention.
- Remember to close and lock all openings on the machine (doors, windows, cowls, etc.).
- If necessary, protect against penetration of water, steam or cleaning agents, components susceptible of being damaged, particularly electrical components and connections and the injection pump.
- Clean the machine of any traces of fuel, oil or grease.

## TRANSPORTING THE MACHINE

---

### ⚠ IMPORTANT ⚠

*Transporting the machine involves real risks for the operator and others involved.*

- Towing, winching, slinging or transporting the machine (⚠ 3 - MAINTENANCE).

## PROLONGED MACHINE SHUTDOWN

### INTRODUCTION

---

### ⚠ IMPORTANT ⚠

*Procedures to follow for long duration standstill and for bringing back the machine into service must be performed by your dealership.*

*This period of long duration standstill must not exceed 12 months.*

*After 12 months, repeat the procedures for putting the machine back into service and long-term shutdown.*

The recommendations below are intended to prevent the machine from being damaged when it is not used for a period of more than 3 months.

### PREPARATION OF THE MACHINE

---

- Clean the machine thoroughly.
- Check and repair any fuel, oil, water or air leaks.
- Replace or repair any worn or damaged parts.
- Wash the painted surfaces of the machine in clear and cold water and wipe them.
- Touch up the paintwork if necessary.
- Lower the lifting structure fully.
- Retract the telescopic arms.
- Release the pressure in the hydraulic circuits.
- Shut down the machine.

### DEF (Diesel Exhaust Fluid) TANK

---

Depending on machine model

- Drain down and rinse the DEF (Diesel Exhaust Fluid) tank.
- Replace the "DEF" (Diesel Exhaust Fluid) feed pump filter (⚠ 3 - MAINTENANCE).
- Slowly fill the tank with new DEF up to the bottom of the filler neck.
- Start up the machine to pressurize the circuit and bring it up to working temperature, then shut down the engine.
- If necessary, top up the tank.

## PROTECTING THE ENGINE

---

- Contact your dealer to obtain the procedure for protecting the inside of the engine (use of protection product).
- Fill the tank with fuel (<img alt="arrow icon" data-bbox="245 85 260 95"/> 3 - MAINTENANCE).
- Replace the engine oil and oil filter (<img alt="arrow icon" data-bbox="245 100 260 110"/> 3 - MAINTENANCE).
- Replace the coolant (<img alt="arrow icon" data-bbox="245 115 260 125"/> 3 - MAINTENANCE).
- Leave the engine running at idling speed for a few minutes, then switch off.
- Run the engine for a short time so that the oil and cooling liquid circulate inside.
- Disconnect the battery and store it in a safe place away from the cold, after charging it to maximum capacity.
- Block the outlet with waterproof adhesive tape.
- Remove the drive belts and store them in a safe place.
- Disconnect the engine cut-off solenoid on the injection pump and carefully insulate the connection.

## MACHINE PROTECTION

---

Place the machine on level ground.

- Set the machine on axle stands so that the tires are off the ground.
- Deactivate the parking brake (*depending on machine model*).
- Protect cylinder rods which will not be retracted from corrosion.
- Wrap the wheels.

N.B.: If the machine is to be stored outdoors, cover it with a waterproof tarpaulin.

## RETURNING THE MACHINE TO SERVICE

---

### **IMPORTANT**

*Make sure the area is adequately ventilated before starting up the machine.*

- Remove the waterproof adhesive tape from all the orifices.
- Remove the protection from the cylinder rods and wheels.
- Refit and reconnect the battery.
- Activate the parking brake and remove the axle stands.
- Perform the daily maintenance operations (<img alt="arrow icon" data-bbox="245 480 260 490"/> 3 - MAINTENANCE).
- Perform the weekly maintenance operations (<img alt="arrow icon" data-bbox="245 495 260 505"/> 3 - MAINTENANCE).
- Drain and clean the fuel tank (<img alt="arrow icon" data-bbox="245 510 260 520"/> 3 - MAINTENANCE).
- Fill the fuel tank with clean diesel filtered through the filler port.
- Replace the fuel filter (<img alt="arrow icon" data-bbox="245 535 260 545"/> 3 - MAINTENANCE).
- Replace the fuel pre-filter (<img alt="arrow icon" data-bbox="245 550 260 560"/> 3 - MAINTENANCE) (*depending on the model of machine*).
- Drain and rinse the DEF tank (*depending on the machine model*).
- Top up, slowly fill the tank with new "DEF" (Diesel Exhaust Fluid) up to the bottom of the filler neck (*depending on the machine model*).
- Refit and set the tension in the belts. (<img alt="arrow icon" data-bbox="245 605 260 615"/> 3 - MAINTENANCE).
- Turn the engine over with the starter, to allow the oil pressure to rise.
- Reconnect the engine cut-off solenoid.
- Lubricate the machine completely (<img alt="arrow icon" data-bbox="245 650 260 660"/> 3 - MAINTENANCE).
- Start up the machine, following the operating and safety instructions (<img alt="arrow icon" data-bbox="245 665 260 675"/> OPERATING INSTRUCTIONS UNLADEN AND LADEN).
- Perform all the lifting structure's hydraulic movements up to the end position for each cylinder.

## DISPOSING OF THE MACHINE



*Consult your dealer before disposing of the machine.*

### RECYCLING OF MATERIALS

---

#### METALS

- Metals are 100% recoverable and recyclable.

#### PLASTICS

- Plastic parts are identified with a marking in accordance with current regulations.
- A limited range of materials is used to simplify the recycling process.
- The majority of the plastic components are made of "thermoplastic" plastics, which are easily recycled by melting, granulating or grinding.

#### RUBBER

- Tires and seals can be ground for use in cement manufacture or to obtain reusable granules.

#### GLASS

- Glass items can be removed and collected for processing by glaziers.

### ENVIRONMENTAL PROTECTION

---

By entrusting the maintenance of your machine to the MANITOU network, the risk of pollution is limited and the contribution to environmental protection is made.

#### WORN OR DAMAGED PARTS

- Do not dump them in the countryside.
- MANITOU and its network have signed-up to a scheme of environmental protection through recycling.

#### USED OIL

- The MANITOU network organizes the collection and processing of used oil.
- By handing over your waste oil to MANITOU, the risk of pollution is limited.

#### USED BATTERIES

- Do not throw away batteries, as they contain metals that are harmful for the environment.
- Return them to the MANITOU network or any other approved collection point.

N.B.: MANITOU aims to manufacture machines that provide the best performance and limit polluting emissions.

# ***2 - DESCRIPTION***



## 2 - DESCRIPTION

<b>"EC" DECLARATION OF CONFORMITY</b>	<b>2-4</b>
<b>"UKCA" DECLARATION OF CONFORMITY</b>	<b>2-6</b>
<b>SAFETY PLATES AND STICKERS</b>	<b>2-8</b>
<b>IDENTIFICATION OF THE LIFT TRUCK</b>	<b>2-12</b>
<b>CHARACTERISTICS</b>	<b>2-14</b>
<b>TYRES</b>	<b>2-16</b>
<b>DIMENSIONS</b> MT 420 H 57K ST5 S1	<b>2-18</b>
<b>DIMENSIONS</b> MT 420 H TSS 57K ST5 S1	<b>2-19</b>
<b>LOAD CHART</b>	<b>2-20</b>
<b>VISIBILITY</b>	<b>2-22</b>
<b>INSTRUMENTS AND CONTROLS</b>	<b>2-24</b>
<b>TOWING DEVICE</b>	<b>2-49</b>
<b>DESCRIPTION AND USE OF THE OPTIONS</b>	<b>2-50</b>



**bg :** (1) *ЕСО декларация за съответствие (оригинал)*, (2) Производител, (3) Адрес, (4) Притежател на техническото досие, (5) Производителът декларира, че описаната по-долу машина, (6) Е в съответствие със следните директиви и тяхното транспониране в националното законодателство (ако е приложимо), (7) Приложение IV относно машините, (8) Номер на сертификата, (9) Нотифициран орган, (10) Приложена процедура, (11) Име на силата на звук, (12) Измерено, (13) Гарантирано, (14) Използвани хармонизирани стандарти, (15) Използвани стандарти или технически разпоредби, (16) Изработено в, (17) Дата, (18) Име на подписаното лице, (19) Длъжност, (20) Фирма, (21) Подпис

**cs :** (1) *ES prohlášení o shodě (původní)*, (2) Výrobce, (3) Adresa, (4) Držitel technické dokumentace, (5) Výrobce prohlašuje, že zařízení popsané níže, (6) Je v souladu s následujícími směrnicemi a směrnicemi transponovanými do vnitrostátního práva (je-li relevantní), (7) Pro stroje v příloze IV(8) Číslo certifikátu, (9) Notifikační orgán, (10) Použitý postup, (11) Úroveň hluku (12) Naměřená, (13) Zaručená, (14) Použitě harmonizované normy, (15) Použitě normy nebo technické předpisy(16) Místo (17) Datum (18) Jméno podepsaného, (19) Funkce, (20) Společnost, (21) Podpis

**da :** (1) *EF Overensstemmelseserklæring (original)*, (2) Producent, (3) Adresse, (4) Indehaver af det tekniske dossier, (5) Producenten erklærer, at maskinen, der er beskrevet nedenfor, (6) overholder nedenstående direktiver og disse gennemførelse til national ret (hvis det er relevant), (7) For maskiner under bilag IV, (8) Certifikatnummer, (9) Bemyndigede organ, (10) Anvendt procedure, (11) Lydeffektivitet, (12) Målt, (13) Garanteret, (14) Anvendte harmoniserede standarder, (15) Standarder eller tekniske regler, (16) Udfærdiget i, (17) Dato, (18) Underskrifters navn, (19) Funktion, (20) Firma, (21) Underskrift.

**de :** (1) *EG-Konformitätsklärung (original)*, (2) Hersteller, (3) Adresse, (4) Inhaber des technischen Dokuments, (5) Der Hersteller erklärt, dass die nachstehend beschriebene Maschine (6) den folgenden Richtlinien und deren Umsetzung in die nationale Gesetzgebung entspricht (falls anwendbar), (7) Für die Maschinen laut Anhang IV, (8) Bescheinigungsnummer, (9) Benannte Stelle, (10) Angewandtes Verfahren, (11) Schalleistungspegel, (12) Gemessen, (13) Gewährleistet, (14) angewandte harmonisierte Normen, (15) angewandte sonstige technische Normen und Bestimmungen, (16) Ausgestellt in, (17) Datum, (18) Name des Unterzeichners, (19) Funktion, (20) Gesellschaft, (21) Unterschrift.

**el :** (1) *Δήλωση συμμόρφωσης CE (πρωτότυπο)*, (2) Κατασκευαστής, (3) Διεύθυνση, (4) Κάτοχος του τεχνικού φακέλου, (5) Ο κατασκευαστής δηλώνει ότι το μηχανήμα που περιγράφεται παρακάτω, (6) Συμμορφώνεται με τις εθνικές οδηγίες και τις προσαρμογές τους στο εθνικό δίκαιο (κατά περίπτωση), (7) Για το μηχανήμα που περιγράφεται στο παράρτημα IV, (8) Αριθμός πιστοποίησης, (9) Αξιολογημένος φορέας, (10) Εφαρμοζόμενη διαδικασία, (11) Στάθμη ηχητικής ισχύος, (12) Καταμετρημένη, (13) Εγγυημένη, (14) Εναρμονισμένα πρότυπα που χρησιμοποιούνται, (15) Πρότυπα ή τεχνικοί κανόνες που χρησιμοποιούνται, (16) Τόπος, (17) Ημερομηνία, (18) Όνομα του υπογράφοντος, (19) Διεύθυνση, (20) Εταιρεία, (21) Υπογραφή

**es :** (1) *Declaración CE de conformidad (original)*, (2) Fabricante, (3) Dirección, (4) Titular del expediente técnico, (5) El fabricante declara que la máquina que se describe a continuación, (6) Cumple con las siguientes directivas y sus transposiciones a la legislación nacional (en caso oportuno), (7) Para las máquinas anexo IV, (8) Número de certificación, (9) Organismo notificado, (10) Procedimiento aplicado, (11) Nivel de potencia acústica, (12) Medido, (13) Garantizado, (14) Normas armonizadas utilizadas, (15) Otras normas o especificaciones técnicas utilizadas, (16) Hecho en, (17) Fecha, (18) Nombre del signatario, (19) Cargo, (20) Empresa, (21) Firma.

**et :** (1) *EU vastavastavastatusekinnitus (algupärane)*, (2) Tootja, (3) Aadress, (4) Tehnilise dokumentatsiooni valdaja, (5) Tootja kinnitab, et allpool kirjeldatud seade, (6) On vastavuses järgmistele direktiivide ja nende realiseerimise õigusse tõlvõtmiseks vastuvõetud õigusaktidega (kui on kohaldatav), (7) IV lisas loetletud seadmete puhul, (8) Tunnistuse number, (9) Sertifitseerimisasutus, (10) Kohaldatav menetlus, (11) Akustilise võimsuse tase, (12) Mõeldud, (13) Tagatud, (14) Vastab kehtivatele ühtlustatud standarditele, (15) Vastab muudele kehtivatele standarditele ja tehnilistele normidele, (16) Väljaandmise koht, (17) Väljaandmise aeg, (18) Allkirjastaja nimi, (19) Amet, (20) Ettevõtte, (21) Allkiri

**fi :** (1) *EY-vaatimustenmukaisuusklausuli (alkuperäinen)*, (2) Valmistaja, (3) Osoite, (4) Teknisten asiakirjojen haltija, (5) Valmistaja ilmoittaa, että alla kuvattu laite, (6) Täyttää seuraavien direktiivien sekä niitä vastaavien kansallisten säätöjen vaatimukset (tarvittaessa), (7) Liitteen IV laitteiden osalta, (8) Todistusnumero, (9) Ilmoitettu laitos, (10) Käytetty menetelmä, (11) Äänen tehotaso, (12) Mittattu, (13) Taattu, (14) Käytetyt yhdenmukaistetut standardit, (15) Käytetyt tekniset standardit tai säännökset, (16) Paikka, (17) Aika, (18) Allekirjoittajan nimi, (19) Toimi, (20) Yritys, (21) Allekirjoitus.

**ga :** (1) *Dearbhu comhréireachta e CE » (bunaidin)*, (2) Déantóir, (3) Seoladh, (4) Sealbhoir an chomhad teicniúil, (5) Dearbhalcinn an déantóir go ndéanann an t-inneal ar a bhíll cur síos thíos, (6) Cíolonn sé le na teoracha seo a leanas agus lena dtrasul isteach i ndá náisiúnta (má cuil), (7) Le haghaidh innéil an agúisín IV, (8) Uimhir ceistais, (9) Comhréir a d'uglar fógra dó, (10) Nós imeachta a cuireadh i bhfeidhm, (11) Leibhéal cumhachta na fuaimne, (12) Tomhasa, (13) Réitheadh, (14) Caighdeán comhchruibhíne a úsáideadh, (15) Caighdeán nó fóirleacha teicniúla a úsáideadh, (16) Ama dhéanamh ag, (17) Dáta, (18) Ainm an tsíneora, (19) Feidhmeannas, (20) Comhréir (21) Síniú.

**hr :** (1) *EK deklaracija o usklađenosti (original)*, (2) Proizvođač, (3) Adresa, (4) Nositelj tehničke dokumentacije, (5) Proizvođač izjavlja da stroj opisan u nastavku, (6) Ispunjava slijedeće direktive i njihovom prijenosu u nacionalno zakonodavstvo (ako je primjenjivo), (7) Za dodatak IV o strojevima, (8) Broj certifikata, (9) Ovlašteno tijelo, (10) Primjenjeni postupak, (11) Razina snage zvuka, (12) Izmjereno, (13) Zajamčeno, (14) Primjenjeni standardi o harmoniziranju, (15) Primjenjeni standardi ili tehničke prirobu, (16) Uradeno u, (17) Datum, (18) Ime potpisnika, (19) Funkcija, (20) Tvrtka, (21) Potpis.

**hu :** (1) *CE megfelelőségi nyilatkozat (eredeti)*, (2) Gyártó, (3) Cím, (4) A műszaki dokumentáció birtokosa, (5) A gyártó kijelenti, hogy az alábbi termék, (6) Megfelel az alábbi irányelveknek valamint azok honosított előírásainak (ha vannak ilyenek), (7) A IV. melléklet gépeihez (adott esetben), (8) Bizonyítási szám, (9) Értékelő szervezet, (10) Alkalmazott eljárás, (11) Akusztikus hang szint, (12) Mért, (13) Garantált, (14) Felhasznált harmonizált szabványok, (15) egyéb felhasznált műszaki szabványok és előírások hivatkozásai, (16) Kelt (hely), (17) Dátum, (18) Aláíró neve, (19) Funkció, (20) Vállalat, (21) Aláírás

**is :** (1) *Sannræmingarveitingar ESB (upprunaleg)*, (2) Framleiðandi, (3) Aðsetur, (4) Handhafi teknískrár, (5) Framleiðandi staðfestir að vélin sem lýst er hér, (6) Samræmist eftirfarandi stöðum og staðfestir þeim með hliðsjón af þjóðarriti (ef við á), (7) Fyrir tekið á eftir í IV. viðauka, (8) Númer vottorðs, (9) Tilkynnt til, (10) Aðrir bærtil, (11) Hjóðstyrkur, (12) Mældist, (13) Ábyrgð, (14) Samhæfir staðir sem notaðir voru, (15) Aðrir staðir eða tæknilegar forsetur, (16) Staður, (17) Dagsetning, (18) Nafn undirritaðs, (19) Staða, (20) Fyrirseti, (21) Underskrift.

**it :** (1) *Dichiarazione CE di conformità (originale)*, (2) Costruttore, (3) Indirizzo, (4) Titolare del fascicolo tecnico, (5) Il costruttore dichiara che la macchina descritta di seguito, (6) È conforme alle direttive seguenti e al relativo recepimento nella normativa nazionale (se applicabile), (7) Per le macchine Allegato IV, (8) Numero di Attestazione, (9) Numero destinatario della notifica, (10) Procedura applicata, (11) Livello di potenza acustica, (12) Misurato, (13) Garantito, (14) Norme armonizzate applicate, (15) Norme e specifiche tecniche applicate, (16) Luogo, (17) Data, (18) Nome del firmatario, (19) Funzione, (20) Società, (21) Firma.

**lt :** (1) *EC atitikties deklaracija (originalas)*, (2) Gamintojas, (3) Adresas, (4) Techninės bylos turėtojas, (5) Gamintojas nurodo, kad mašina, aprašyta žemiau, (6) atitinka toliau nurodytas direktyvas ir j nacionalinius teisės aktus perkeltas jų nuostatose (jei taikytina), (7) IV priedas dėl mašinų, (8) Sertifikuoti Nr., (9) Notifikuotji įstaiga, (10) Taikyta procedūra, (11) Garsio stiprumo lygis, (12) Išmatuotas, (13) Garantuoti, (14) Naudojami standartai, (15) Nėli naudojami standartai ir techninės specifikacijos, (16) Pasirašyta, (17) Data, (18) Pasirašytojo asmens vardas ir pavardė, (19) Pareigos, (20) Bendrovė, (21) Parašas

**lv :** (1) *EK atbilstības deklarācija (originala)*, (2) Ražotāja, (3) Adrese, (4) Tehniskās dokumentācijas turētājs, (5) Ražotājs apliecinā, ka turpmāk aprakstītā mašīna, (6) Atbilst norādītajām direktīvajām un to iekļaušanai nacionālajā likumdošanā (ja piemērojama), (7) IV pielikuma iekārtām, (8) Sertifikāta numurs, (9) Pilsimvoti iestāde, (10) Piemērotā procedūra, (11) Skajas jaudas līmenis, (12) Izmērīts, (13) Garantēti, (14) Piemērojamas iestāžu standarti, (15) Piemērojamas tehniskie standarti un noteikumi, (16) Sastādīts, (17) Datums, (18) Parakstītāja vārds, (19) Amats, (20) Uzņēmums, (21) Paraksts

**mt :** (1) *Dikjarazzjoni ta' Konformità ta' KE (original)*, (2) Manifattur, (3) Indirizz, (4) Detentur ta' fajl tekniku, (5) Il-manifattur jiddeklara li l-magna deskrita hawn taħt, (6) Hija konformi hija konformi mad-Direttivi segwenti u l-bijgjet li jipjegawhom fl-ajl nazzjonali (jekk applikabbli), (7) Ghali-magni fl-Anness IV, (8) Numru ta'-certifikat, (9) Entità notifkatta, (10) Proċedura applikata, (11) Livell ta' gweva akustika, (12) Imkejjel, (13) Garantit, (14) I-standardi armonizzati użati, (15) standardi tekniċi u speċifikazzjonij oħra użati, (16) Magħmuf f, (17) Data, (18) Isem il-firmatarju, (19) Kariga, (20) Kumpanija (21) Firma.

**nl :** (1) *EG-verklaring van overeenstemming (oorspronkelijke)*, (2) Fabrikant, (3) Adres, (4) Houder van het technisch dossier, (5) De fabrikant verklaart dat de hieronder beschreven machine, (6) In overeenstemming is met de volgende richtlijnen en hun omzettingen in het nationale recht (indien van toepassing), (7) Voor de machines in bijlage IV, (8) Certificatnummer, (9) Aangemelde instantie, (10) Toegepaste procedure, (11) Geluidsvermogensniveau, (12) Gemeten, (13) Gegarandeerd, (14) gehanteerde geharmoniseerde normen, (15) andere gehanteerde technische normen en specificaties, (16) Opgemaakt te, (17) Datum, (18) Naam van ondergetekende, (19) Functie, (20) Onderneming, (21) Handtekening.

**no :** (1) *CE-samsvarserklæring (original)*, (2) Produsent, (3) Adresse, (4) innehaveren av den tekniske dokumentasjonen, (5) Produsenten sier at maskinen beskrevet nedenfor, (6) Oppfyller kravene i følgende direktiver og med nasjonale gjennomføringsbestemmelser (hvis aktuelle), (7) For maskinene i bilag IV, (8) Attestnummer, (9) Teknisk kontrollorgan, (10) Anvendt prosedyre, (11) Akustisk støy, (12) Målt, (13) Garantert, (14) harmoniserte standarder som brukes, (15) Andre standarder og spesifikasjoner som brukes, (16) Utstedt, (17) Dato, (18) Underordnetes navn, (19) Stilling, (20) Firma (21) Underskrift

**pl :** (1) *Deklaracja zgodności CE (oryginal)*, (2) Producent, (3) Adres, (4) Posiadacz dokumentacji technicznej, (5) Producent oświadcza, że opisana poniżej maszyna, (6) Jest zgodna z następującymi dyrektywami i odpowiedzonymi im przepisami prawa krajowego (jeżeli dotyczy), (7) Dla maszyn załącznik IV, (8) Numer certyfikatu, (9) Jednostka certyfikująca, (10) Procedura stosowana, (11) Poziom mocy akustycznej, (12) Zmierzony, (13) Gwarantowany, (14) zastosowane normy zharmonizowane, (15) Zastosowane normy lub przepisy techniczne, (16) Sporządzono w, (17) Data, (18) Nazwisko podpisującego, (19) Stanowisko, (20) Firma (21) Podpis

**pt :** (1) *Declaração de conformidade CE (original)*, (2) Fabricante, (3) Morada, (4) Titular do processo técnico, (5) O fabricante afirma que a máquina descrita abaixo, (6) Está em conformidade com as seguintes diretrizes e as suas transposições para o direito nacional (se for o caso), (7) Para as máquinas no anexo IV, (8) Número de certificado, (9) Entidade notificada, (10) Procedimento aplicado, (11) Nível de potência acústica, (12) Medida, (13) Garantida, (14) normas harmonizadas utilizadas, (15) outras normas e especificações técnicas utilizadas, (16) Elaborado em, (17) Data, (18) Nome do signatário, (19) Cargo, (20) Empresa, (21) Assinatura

**ro :** (1) *Declaratie de conformitate CE (original)*, (2) Producător, (3) Adresa, (4) Titularul din dosarul tehnic, (5) Producătorul afirmă că aparatul descris mai jos, (6) Este conform cu directivele următoare și cu transpunerea lor în dreptul național (dacă este cazul), (7) Pentru mașinile din anexa IV, (8) Număr de atestare, (9) Organism notificat, (10) Procedura aplicată, (11) Nivel de putere acustică, (12) Măsurat, (13) Garantat, (14) standardele armonizate utilizate, (15) alte standarde și specificații tehnice utilizate, (16) Încolmit în, (17) Data, (18) Numele persoanei care semnează, (19) Funcția, (20) Firma, (21) Semnătură

**sk :** (1) *Vyhlasenie o zhode ES (pôvodné)*, (2) Výrobca, (3) Adresa, (4) Držiteľ technickej dokumentácie, (5) Výrobca vyhlasuje, že nižšie popísaný stroj, (6) Je v súlade s nasledujúcimi smernicami a smernicami transponovanými do vnitrostátného práva (v prípade potreby), (7) Pre stroje v prílohe IV, (8) Číslo certifikátu, (9) Notifikačný orgán, (10) Použitý postup, (11) Akustická úroveň hluku, (12) Nameraná, (13) Zaručená, (14) Použitě harmonizované normy, (15) Iné použité normy a technické předpisy, (16) Miesto vydania, (17) Dátum vydania, (18) Měno podepsané osoby, (19) Funkcia, (20) Spoločnosť, (21) Podpis

**sl :** (1) *ES izjava o skladnosti (izvirnik)*, (2) Proizvajalec, (3) Naslov, (4) Imetnik tehnične dokumentacije, (5) Proizvajalec izjavlja, da naprava, opisana v nadaljevanju, (6) Ustreza naslednjim direktivam in nacionalni zakonodaji (če ta velja), (7) Za stroje v prilogi IV, (8) Številka potrdila, (9) Pregledni organ, (10) Uporabljen postopek, (11) Raven akustične moči, (12) izmerjena, (13) Zajamčena, (14) Uporabljeni izkrajni standardi, (15) Drugi uporabljeni tehnični standardi in specifikacije, (16) V, (17) Datum, (18) Ime podpisnika, (19) Funkcija, (20) Podjetje, (21) Podpis.

**sv :** (1) *EG-försäkran om överensstämmelse (original)*, (2) Tillverkare, (3) Adress, (4) Ägaren av det tekniska underlaget, (5) Tillverkaren försäkras att den maskin som beskrivs nedan, (6) Överensstämmer med nedanstående direktiv och införlivningar av dem i nationellt rätt (om tillämpligt), (7) För maskinerna i bilaga IV, (8) Nummer för godkännande, (9) Anmält organ, (10) Förfarande som tillämpats, (11) Ljudstyrkenivå, (12) Uppmätt, (13) Garanterad (14) Harmoniserade standarder som använts, (15) andra tekniska standarder och specifikationer som använts, (16) Upprättat i, (17) Datum, (18) Namn på den som undertecknat, (19) Befattning, (20) Företag (21) Namnteckning

## UKCA DECLARATION OF CONFORMITY

Manufacturer: **MANITOU BF**  
Address: **430, RUE DE L'AUBINIÈRE - BP 10249  
44158 ANCENIS CEDEX - FRANCE**  
Authorized representative: **MANITOU UK  
Ebblake Industrial Estate - Dorset BH 31 6BB  
Verwood - United Kingdom**

The manufacturer declares that the below described machinery:  
**COMPACT ROUGH-TERRAIN VARIABLE-REACH TRUCK**

**MT 420 H 57K ST5 S1  
MT 420 H TSS 57K ST5 S1**

Complies with the following legislation:

**The supply of Machinery (Safety) Regulations 2008, as amended**

The machine is designed for the lifting of persons:

Applied procedure: Non applicable  
Certificate number: Non applicable  
Dated:  
Approved body: Non applicable

**Noise Emission in the Environment by Equipment  
for use Outdoors Regulations 2001, as amended**

Applied procedure: Schedule 11  
Approved body: TÜV SÜD INDUSTRIE SERVICE GMBH  
WESTENDSTRASSE 199  
80686 MUNICH - GERMANY

Sound power level:  
Measured: dB (A)  
Guaranteed: dB (A)

**Electromagnetic Compatibility Regulations 2016, as amended**

The following designated standards have been addressed:

EN 12895

The following standards or technical guidance have been addressed:

EN 1459

At: Date:  
Name of signatory:  
Position:  
Company:  
Signature:



## SAFETY PLATES AND STICKERS

### ⚠ IMPORTANT ⚠

Clean all stickers and safety plates so that they are legible.  
Any safety plates and stickers which are illegible or damaged must be replaced.  
Check that stickers and safety plates are present after replacing any spare parts.

### EXTERNAL PLATES AND STICKERS

REF.	PART NO.	DESCRIPTION
1	234805	- Hydraulic coupling instruction
2	296998	- Maniscopic safety instruction
3	24653	- Slings point
4	52563320	- Tie-down point
5	288430	- Repairing instructions (on lift cylinder)
6	268491	- Brake fluid instruction
7	305405	- Diesel fuel
8	289013	- Towing instruction (OPTION)
9	307508	- Battery cut-off instruction
10	233088	- Preheat rod (OPTION)
11	52562266	- Travel repair
12	289625	- Easy attachment connection (OPTION)
13	250707	- Fan reversal (OPTION)
14	52631112	- Overall height (OPTION)

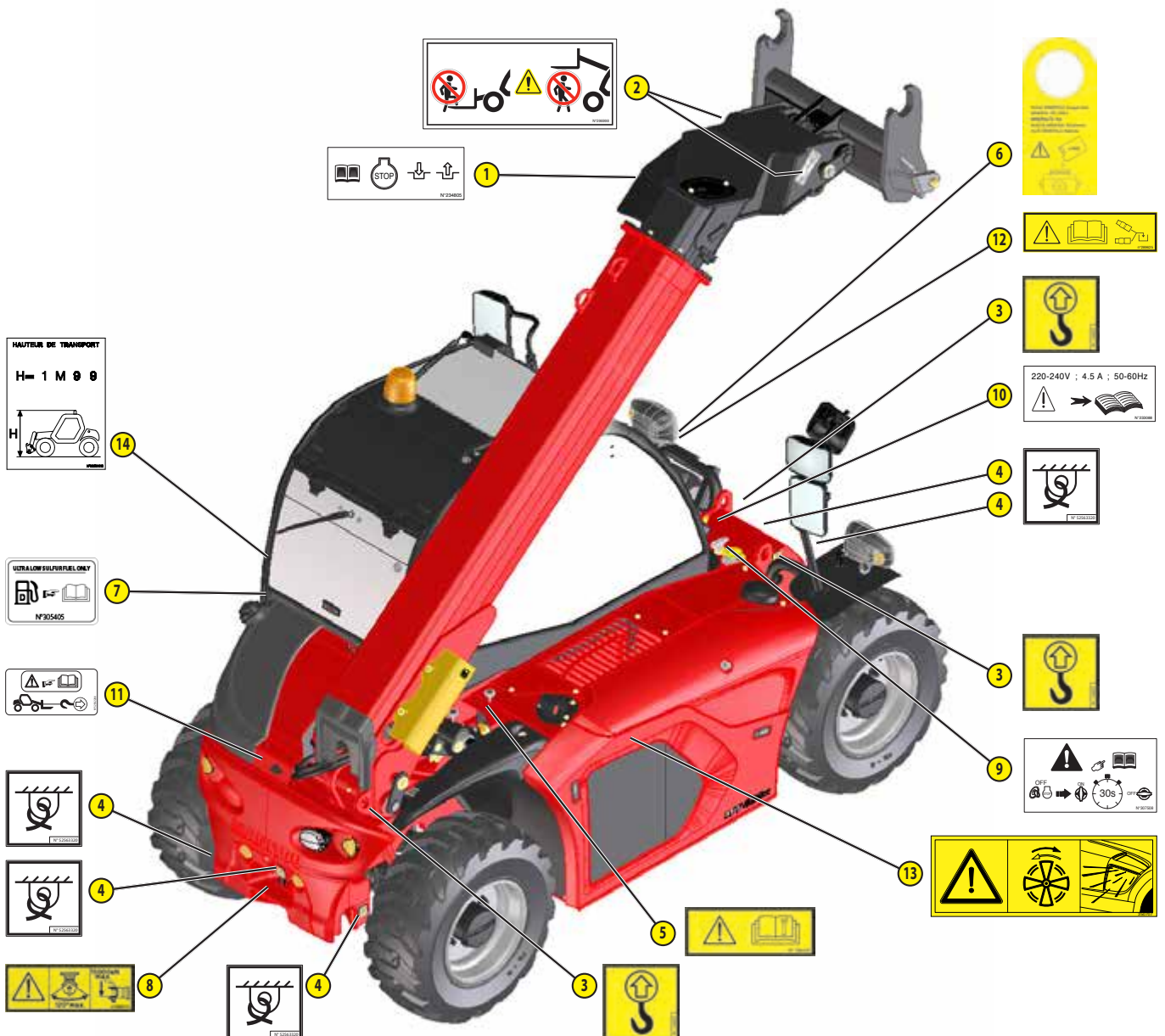

## STICKERS AND PLATES UNDER THE ENGINE HOOD

REF.	PART NO.	DESCRIPTION
1	259398	- Water/diesel separator
2	293887	- Anti-freeze
3	52582287	- Caution, hot surface
4	234797	- Air conditioning (OPTION)



## PLATES AND STICKERS IN THE CAB

REF.	PART NO.	DESCRIPTION
1	240805	- Reach chart sheet
2	52509004	- Manipulator function sheet
3	241621	- Safety instruction sheet
5	52612237	- Fuse sheet
6	52612229	- Relay sheet
7	294831	- Reset procedure sheet
8	52564339	- Lubrication sheet
9	290183	- Bucket instruction on telescope
10	297733	- Operating mode management instruction
11	52515381	- Main functions
12	265284	- Lifting ring on carriage (OPTION)
13	184276	- Steering selection
14	52580160	- Towing forbidden
15	239594	- Sound power level
16	52573932	- Cab compliance
17	52521685	- Diesel exhaust particle filter regeneration function sheet
18	52651762	- Hydraulic controls activation (DEPENDENT ON ASSEMBLY)
19	52679779	- Consumption sheet
20	52759172	- WARNING risk of misuse (For UK only)

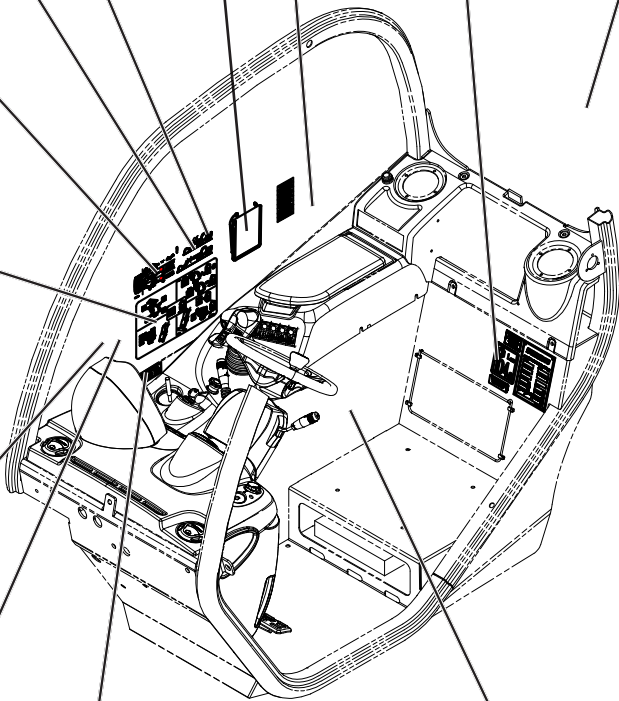
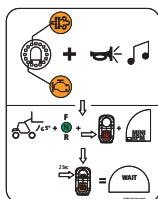
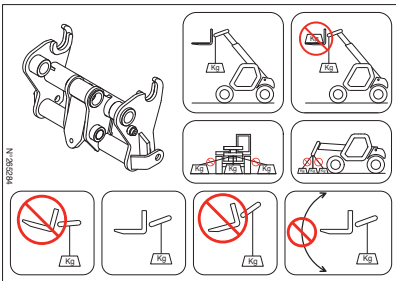
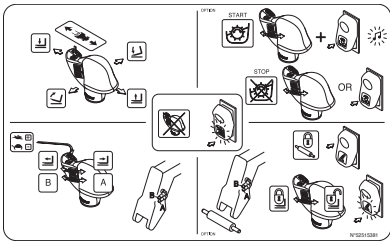
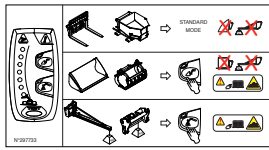
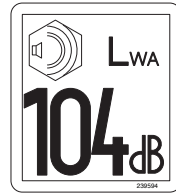
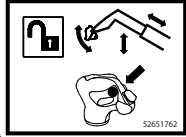
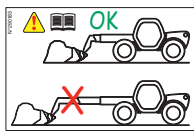
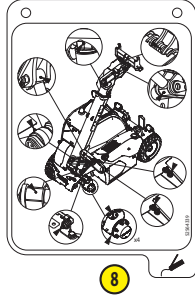
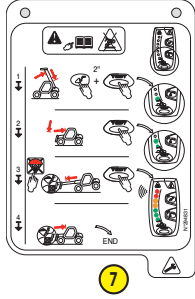
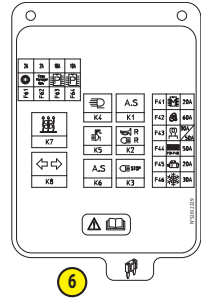
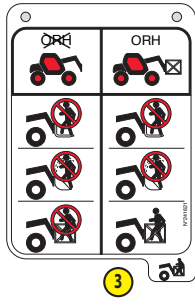
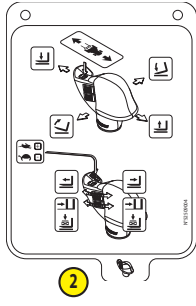

## IDENTIFICATION OF THE LIFT TRUCK

As our policy is to promote a constant improvement in our products, our range of lift trucks may undergo certain modifications, without any obligation for us to advise our customers.

When you order parts, or when you require any technical information, always specify:

NOTE: For the owner's convenience, it is recommended that a note of these numbers is made in the spaces provided, at the time of the delivery of the lift truck.

For any further technical information regarding your lift truck refer to the chapter: CHARACTERISTICS.

### LIFT TRUCK MANUFACTURER'S PLATE

"Designation" Designation	
"Series" Standard	
"Year of manufacture" Year of manufacture	
"Model year" Model year	
"Serial Number / Product Identification Number" Serial number/Product identification number	
"Unladen mass" Unladen weight	
"Power" Power	
"Authorized gross vehicle weight" Authorised gross vehicle weight	
"Rated capacity" Rated capacity	
"Max vertical force (on trailer hook)" Maximum vertical force (on towing hook)	
"Drag strain" Tractive effort	



### ENGINE

"MODEL" Model	
"FAMILY" Family	
"POWER" Power	



### HYDROSTATIC PUMP

MANITOU Part No.	
Codification	
Manufacturing number	
Serial number	
Date of manufacture	



### HYDROSTATIC MOTOR

MANITOU Part No.	
Codification	
Manufacturing number	
Serial number	
Date of manufacture	



**FRONT AXLE**

Type	
Serial number	
MANITOU part No.	



**REAR AXLE**

Type	
Serial number	
MANITOU part No.	



**CAB**

"Constructeur" Manufacturer	
"Type Cabine" Cabin type	
"Numéro de série" Serial number	



**BOOM**

MANITOU Part No.	
Date of manufacture and manufacturer	



**FRAME**

Serial number/Product identification number	
---	--



**ATTACHMENT MANUFACTURER'S PLATE**

"MODELE" Model	
"N° série" Serial number	
"Année Fabrication" Year of manufacture	
"Masse à vide" Unladen weight	
"Centre de gravité" Centre of gravity	
"Capacité Nominale" Rated capacity	
"Pression service" Working pressure	



## CHARACTERISTICS

ENGINE		
Type		KUBOTA V2607
Fuel		Diesel
Number of cylinders		4 in line
Suction		-
Injection system		Direct
Ignition sequence		1.3.4.2
Capacity	cm <sup>3</sup>	2615
Bore and stroke	mm	87 x 110
Compression ratio		20
Nominal speed laden	rpm	2700
Min. rpm unladen	rpm	1000
Max. rpm unladen	rpm	2900
Power ISO 3046-1	hp - kW	57 - 42
Power SAE J 1995	hp - kW	57 - 42
Maximum torque ISO 3046-1	Nm	174 at 1600 rpm
Air filtration efficiency	%	99,9
Type of cooling		By water
Fan		Puller

TRANSMISSION		
Hydrostatic pump		DANFOSS
- Type		Variable displacement piston motor
- Forward/reverse selector		Electro-hydraulic
- Number of forward speeds		2 (1 slow and 1 fast)
- Number of reverse speeds		2 (1 slow and 1 fast)
Main pump		
- MAX./MIN. displacement	cm <sup>3</sup> /rev	0 - 53
- MAX. flow rate	ℓ/mn	138
- Working pressure	bar	350
Booster pump		
- Capacity	cm <sup>3</sup> /rev	12
- MAX. flow rate	ℓ/mn	31
- Boost pressure MAX. speed	Bar	24 (transmission in neutral)
Hydrostatic motor		DANFOSS
- Type		Variable displacement engine
- MAX./MIN. displacement	cm <sup>3</sup> /rev	30-80
Transfer gear box		DANA
Front axle		DANA
- Differential		45 % limited slip differential
Rear axle		DANA
- Differential		45 % limited slip differential
Drive wheels		Permanent 4 WD
- 2/4 wheel drive control		No
Front tyres		SOLIDEAL
- Size		12-16,5 12PR SKS XT TUBELESS
- Pressure	bar	5,6
Rear tyres		SOLIDEAL
- Size		12-16,5 12PR SKS XT TUBELESS
- Pressure	bar	5,6

ELECTRIC CIRCUIT		
Battery		12 V - 110 Ah - 750 A EN
Alternator		12 V - 80 A
- Type		A5TA59 77C
Starter		12 V - 2,5 kW
- Type		1G77263011

SOUND AND VIBRATION		
Sound pressure level in the driver's cab LpA (as per standard EN 12053)	dB(A)	76 (cab closed); xx (cab open)
Sound pressure (according to directive 2009/76)	dB(A)	xx (cab closed); xx (cab open)
Sound pressure level ensured in the LwA environment (according to directive 2000/14/EC modified by directive 2005/88/EC)	dB(A)	104 (measured); 104 (guaranteed)
Sound level in motion (according to directive 2009/63)	dB(A)	xx
Average weighted acceleration on driver's body (as per standard EN 13059)	m/s <sup>2</sup>	1,1
The average weighted acceleration transmitted to the driver's hand/ arm system (according to ISO 5349-2)	m/s <sup>2</sup>	< 2,5
Standard seat vibration	m/s <sup>2</sup>	xx (lightweight operator); xx (heavyweight operator)

<b>BRAKE CIRCUIT</b>	
Service brake	Hydraulic power brake
- Type of brake	Disc brake on front axle
- Type of control	By foot on rear axles
Parking brake	Low pressure hydraulic brake
- Type of brake	Disc brake on front axle
- Type of control	Switch-operated electro-hydraulic

<b>HYDRAULIC CIRCUIT</b>			
Hydraulic pump			
- Type		with gears	
		1st casing	2nd casing
- Capacity	cm <sup>3</sup>	26,7	14,5
- Max. rating capacity unladen	ℓ/min	77,4	42,1
- Flow rate at 1600 rpm	ℓ/min	42,7	23,2
Filtration			
- Return	µm	10	-
- Suction	µm	135	-
Maximum service pressure		235	
- Telescoping circuit	bar	180 / 235	
- Lifting circuit	bar	235 / 235	
- Tilting circuit	bar	235 / 235	
- Attachment circuit	bar	235	
- Steering circuit	bar	140	

<b>HYDRAULIC MOVEMENTS</b>		
Longitudinal stability limiter and warning device		Electronic
Lifting motions (boom retracted)		
- Unladen lifting	s - m/min	5 - 37,2
- Laden lifting	s - m/min	6,5 - 28,6
- Unladen lowering	s - m/min	3,5 - 53,1
- Laden lowering	s - m/min	3,5 - 53,1
Telescoping motions (boom raised)		
- Unladen extending	s - m/min	4,8 - 18
- Laden extending	s - m/min	5 - 18,8
- Unladen retracting	s - m/min	3 - 30
- Laden retracting	s - m/min	3 - 30
Tilting movements		
- Unladen digging	s - °/s	3,3 - 38,8
- Unladen discharging	s - °/s	2,7 - 47,4

<b>SPECIFICATIONS AND WEIGHTS</b>			
Speed of movement for lift truck in standard configuration on flat ground			
• Front unladen	1 slow	km/h	8
•	1 fast	km/h	25
• Rear unladen	1 slow	km/h	8
•	1 fast	km/h	25
Standard attachment		PFB 20 MT 1020	
- Weight of attachment (without forks)	kg	67	
- Weight of forks (each)	kg	44	
Rated capacity with standard attachment		kg	
Tipping load at maximum reach on tires		kg	
Distance from the centre of gravity of the load to the base of the forks		mm	
		500 (EXCEPT FOR AUSTRALIA) 600 (ONLY FOR AUSTRALIA)	
Standard lifting height		mm	
Lift truck weight without attachment		kg	
Weight of lift truck with standard attachment			
- Unladen	kg	4190	
- At rated load	kg	6190	
Weight per axle with standard attachment (transport position)			
- Front unladen	kg	1985	
- Rear unladen	kg	2205	
- Front rated load	kg	5505	
- Rear rated load	kg	685	
Weight per axle with standard attachment (boom extended)			
- Front rated load	kg	4665	
- Rear rated load	kg	425	
Drag strain on the coupling hook			
- Unladen (sliding)	daN	2780	
- At rated load (transmission setting)	daN	2850	
Breakout force with bucket (according to ISO 8313)		daN	
		1886	

## TYRES

		PRESSURE (bar)	LOAD PER TYRE (kg)			
			FRONT UNLADEN	FRONT LADEN	REAR UNLADEN	REAR LADEN
SOLIDEAL	12-16,5 12PR SKS CL	5,6	1000	2750	1100	350
	12-16,5 12PR SKS 732	5,6				
HAULER	12-16,5 12PR SKS	5,6				
	12-16,5 12PR SKZ	5,6				
MICHELIN	300/70 R16,5 137A5/137B	5				
	305/70 R16,5 141A5 TL	5				

		PRESSURE (bar)	LOAD (kg)	GROUND CONTACT PRESSURE (kg/cm <sup>2</sup> )		GROUND CONTACT AREA (cm <sup>2</sup> )	
				HARD GROUND	SOFT GROUND	HARD GROUND	SOFT GROUND
SOLIDEAL	12-16,5 12PR SKS CL	5,6	350				
			1000				
			1100				
			2750				
	12-16,5 12PR SKS 732	5,6	350				
			1000				
			1100				
			2750				
HAULER	12-16,5 12PR SKS	5,6	350				
			1000				
			1100				
			2750				
	12-16,5 12PR SKZ	5,6	350				
			1000				
			1100				
			2750				
MICHELIN	300/70 R16,5 137A5/137B BIBSTEEL HARD SURFACE	5	350				
			1000				
			1100				
			2750				
	305/70 R16,5 141A5 TL BIBSTEEL ALL TERRAIN	5	350				
			1000				
			1100				
			2750				



## DIMENSIONS MT 420 H 57K ST5 S1

<b>A</b>	mm	1200
<b>B</b>	mm	2130
<b>C</b>	mm	1038
<b>C1</b>	mm	978
<b>D</b>	mm	3638
<b>D1</b>	mm	3578
<b>D2</b>	mm	3012
<b>E</b>	mm	4838
<b>F</b>	mm	1169
<b>F1</b>	mm	1169
<b>G</b>	mm	268
<b>G1</b>	mm	240
<b>G2</b>	mm	265
<b>I</b>	mm	470
<b>J</b>	mm	797
<b>K</b>	mm	1015
<b>L</b>	mm	40
<b>N</b>	mm	1350
<b>O</b>	mm	100
<b>P2</b>	°	27
<b>P3</b>	°	62
<b>R</b>	mm	2900
<b>S</b>	mm	6364
<b>T</b>	mm	2850
<b>U1</b>	mm	1965
<b>U2</b>	mm	2065
<b>V</b>	mm	4170
<b>V1</b>	mm	1320
<b>V2</b>	mm	3061
<b>W</b>	mm	1490
<b>Y</b>	°	12
<b>Z</b>	°	116

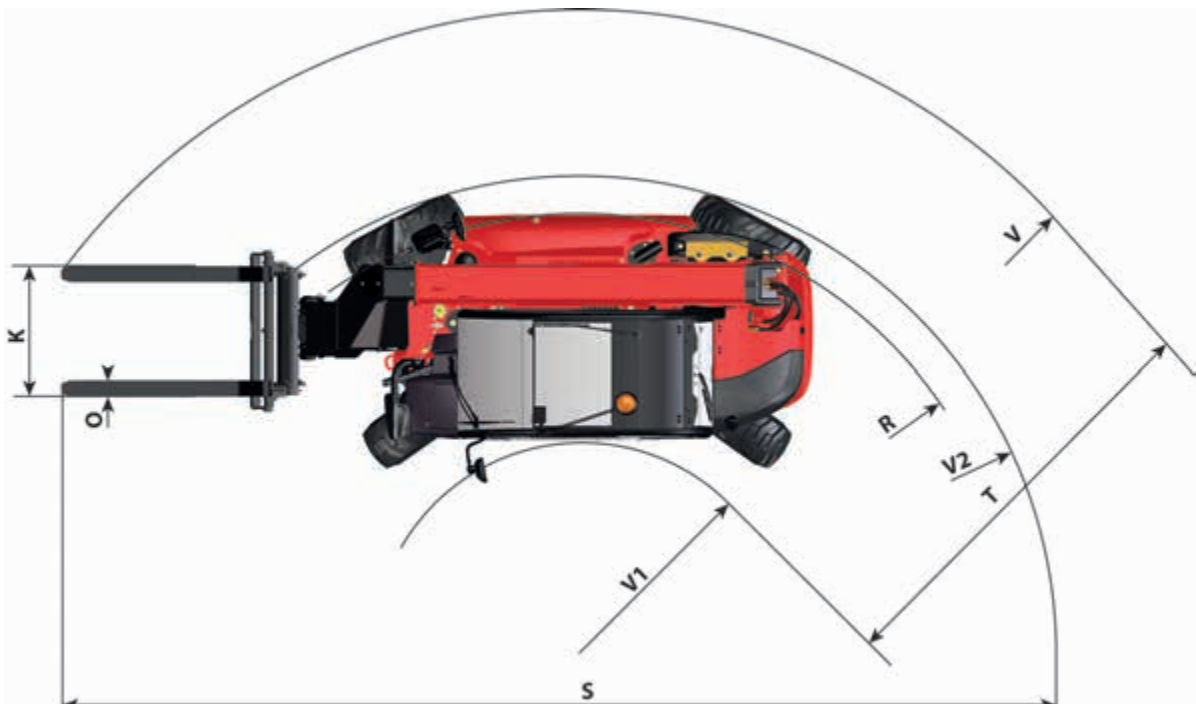
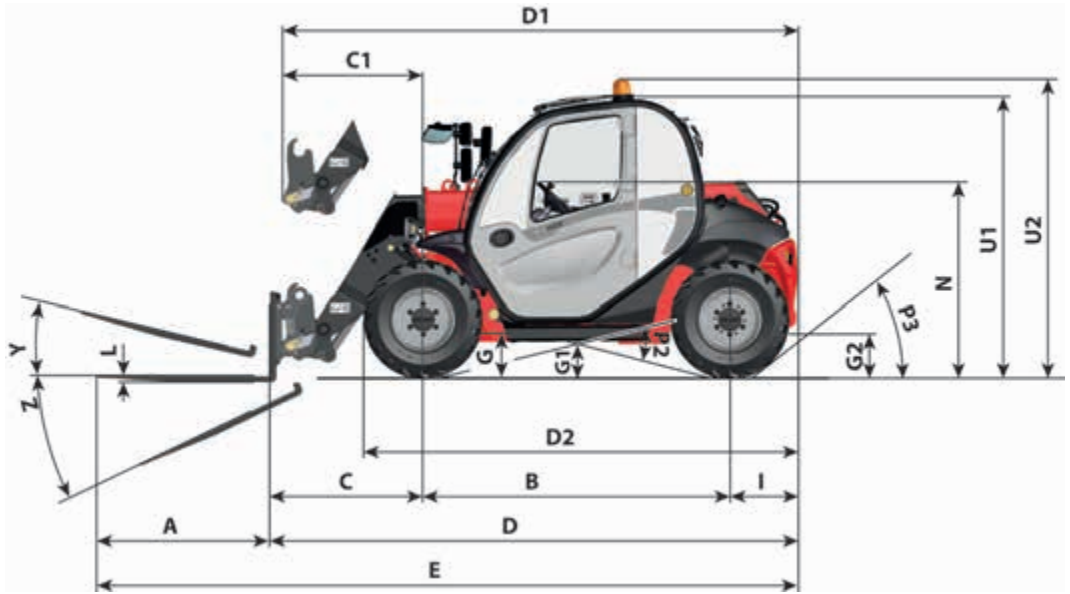

## DIMENSIONS MT 420 H TSS 57K ST5 S1

<b>B</b>	mm	2130
<b>C1</b>	mm	978
<b>D1</b>	mm	3578
<b>D2</b>	mm	3012
<b>F</b>	mm	1169
<b>F1</b>	mm	1169
<b>G</b>	mm	268
<b>G1</b>	mm	240
<b>G2</b>	mm	265
<b>I</b>	mm	470
<b>J</b>	mm	797
<b>N</b>	mm	1350
<b>P2</b>	°	27
<b>P3</b>	°	62
<b>R</b>	mm	2900
<b>S</b>	mm	6364
<b>T</b>	mm	2850
<b>U1</b>	mm	1965
<b>U2</b>	mm	2065
<b>V</b>	mm	4170
<b>V1</b>	mm	1320
<b>V2</b>	mm	3061
<b>W</b>	mm	1490

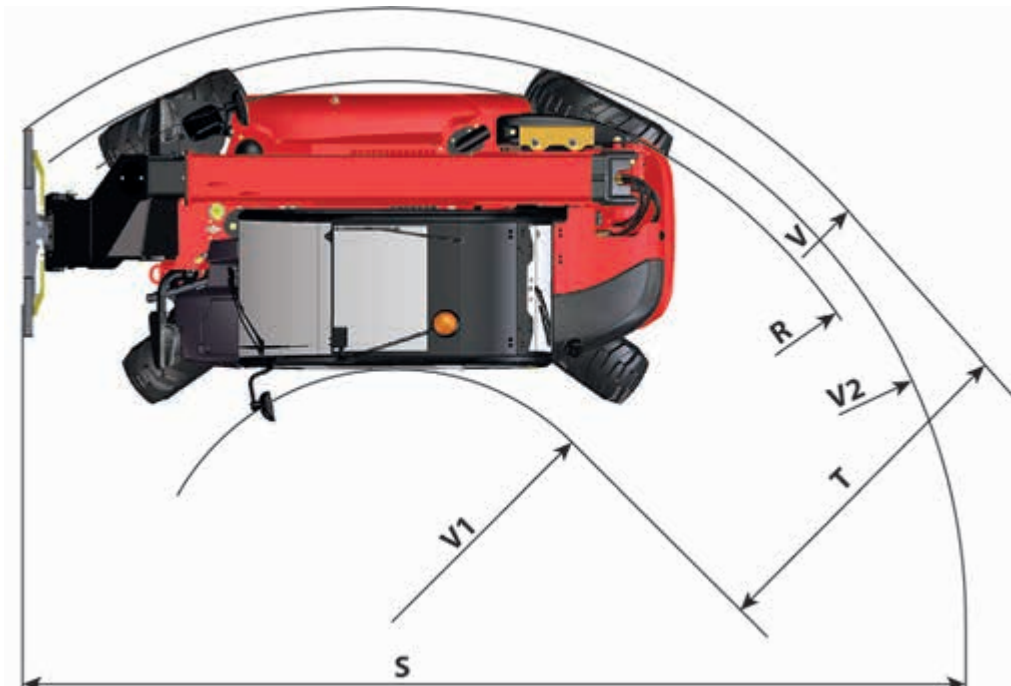
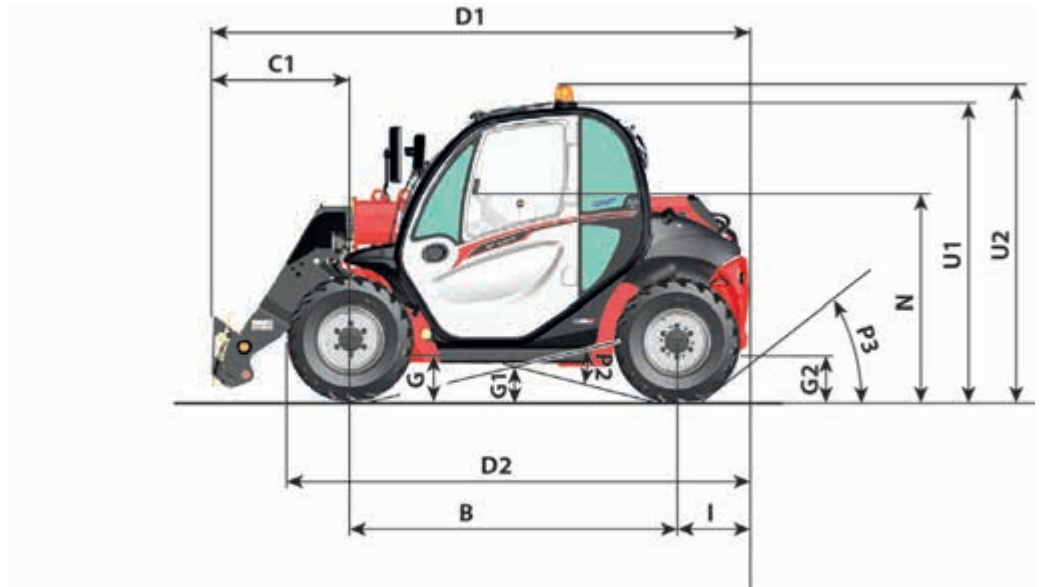

# LOAD CHART

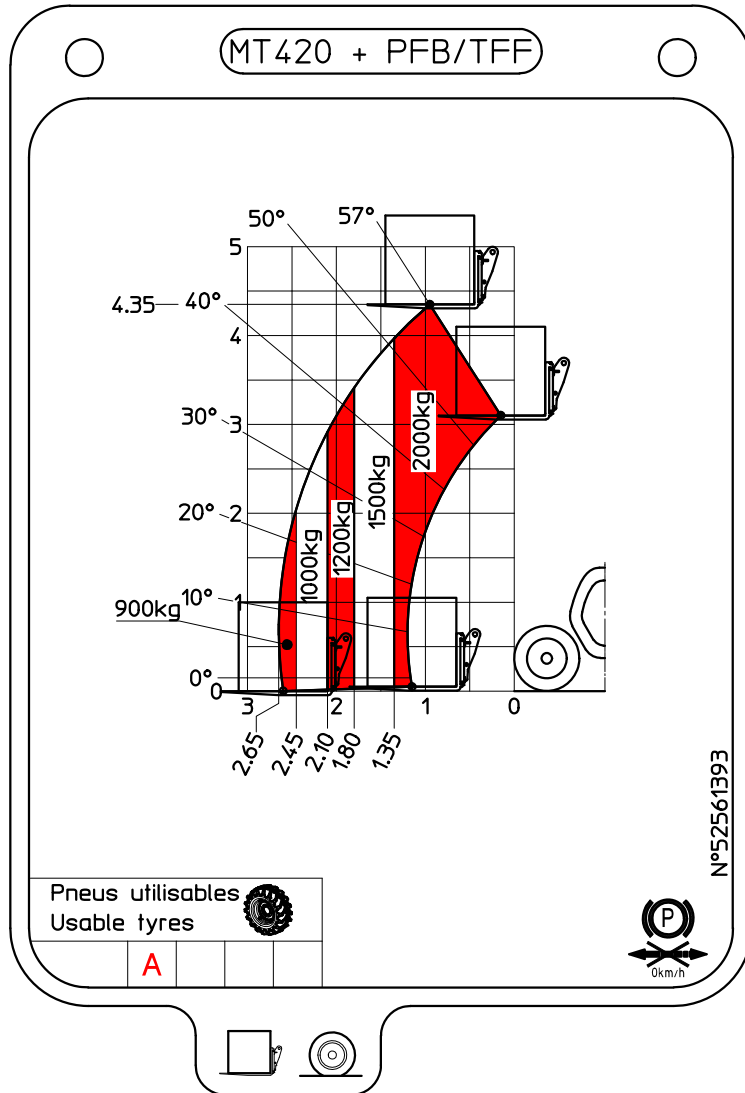

## ONLY FOR AUSTRALIA

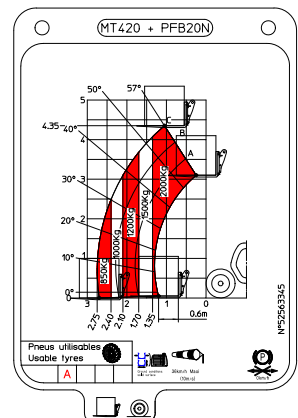
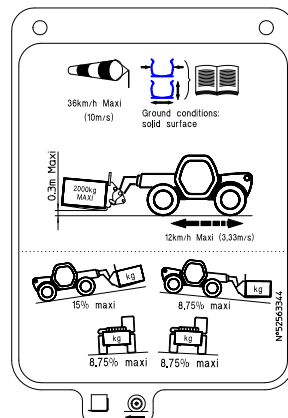
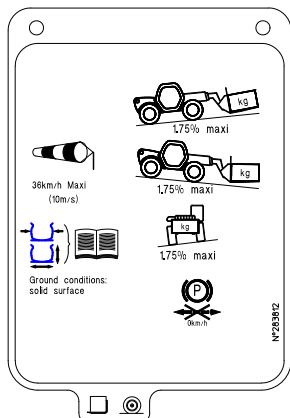



## VISIBILITY

We use European standard EN15830 relating to operator visibility.

- Adhere to the instructions for optimising operator visibility in the immediate vicinity (⇐ 1 - OPERATING AND SAFETY INSTRUCTIONS: INSTRUCTIONS TO THE OPERATOR: DRIVING INSTRUCTIONS UNLADEN AND LADEN: D - VISIBILITY).

### DESCRIPTION AND ADJUSTMENT OF REAR-VIEW MIRRORS

- 1 - LEFT REAR-VIEW MIRROR
- 2 - MAIN RIGHT REAR-VIEW MIRROR
- 3 - CENTRAL RIGHT REAR-VIEW MIRROR
- 4 - UPPER RIGHT REAR-VIEW MIRROR
- 5 - INSIDE REAR-VIEW MIRROR (OPTION)

- Place the lift truck on level ground with the engine stopped, and the boom retracted and lowered as far as possible.
- Note the position of the reference points ●...○ in the illustrations, to see and correctly adjust the rear-view mirrors.

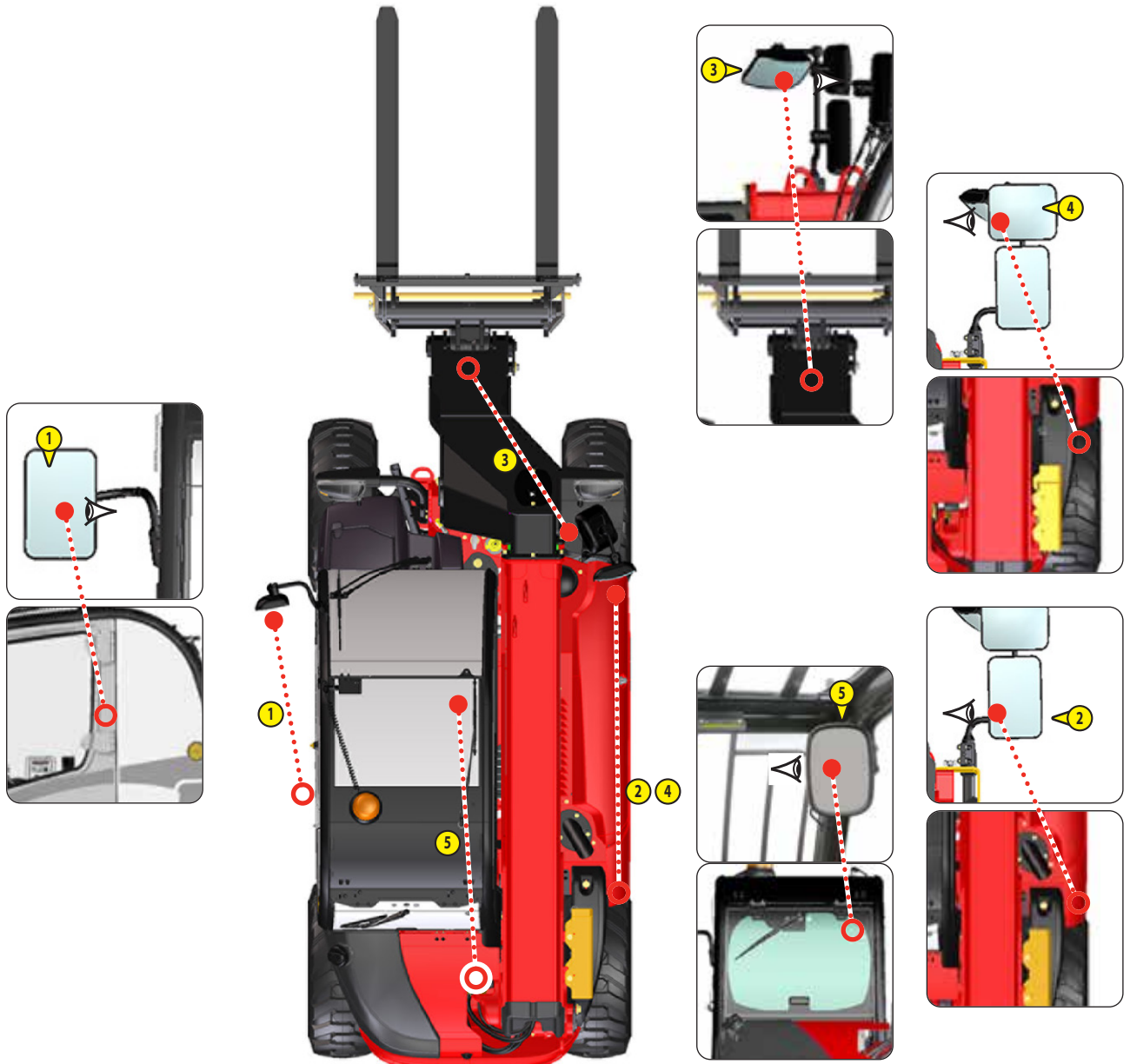

**DIRECT AND/OR INDIRECT VISIBILITY BLIND SPOT ZONES**

The two diagrams below indicate blind spot zones on the visibility test circle (12m radius) and the 1m rectangular zone around the lift truck, according to tests carried out in accordance with EN 15830.

**HANDLING SUSPENDED LOADS** (Test carried out in accordance with 6.3.3 of EN 15830)

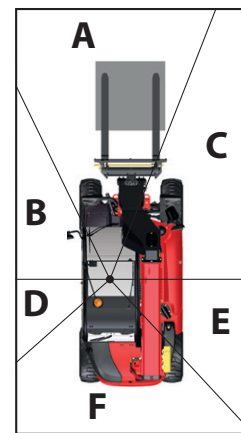
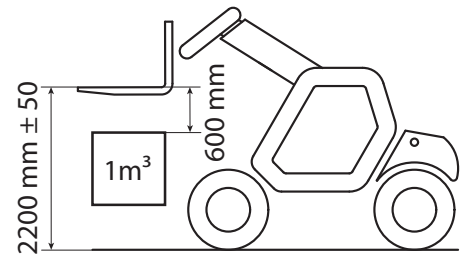
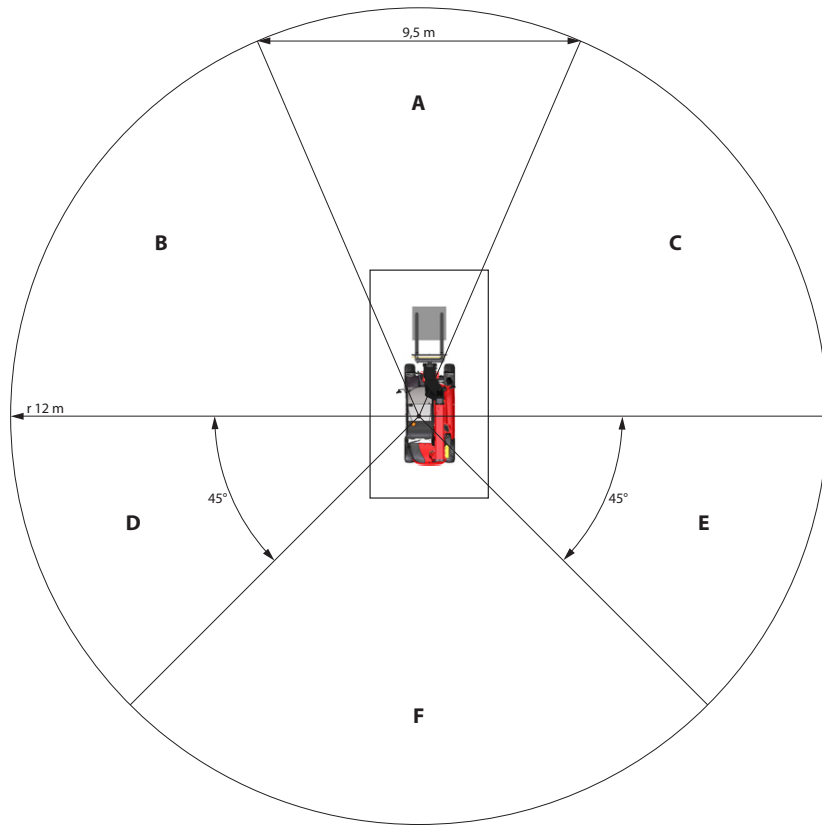

**LOADING THE TRAILER** (Test carried out in accordance with 6.3.4 of EN 15830)

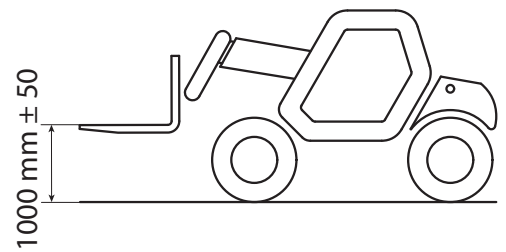
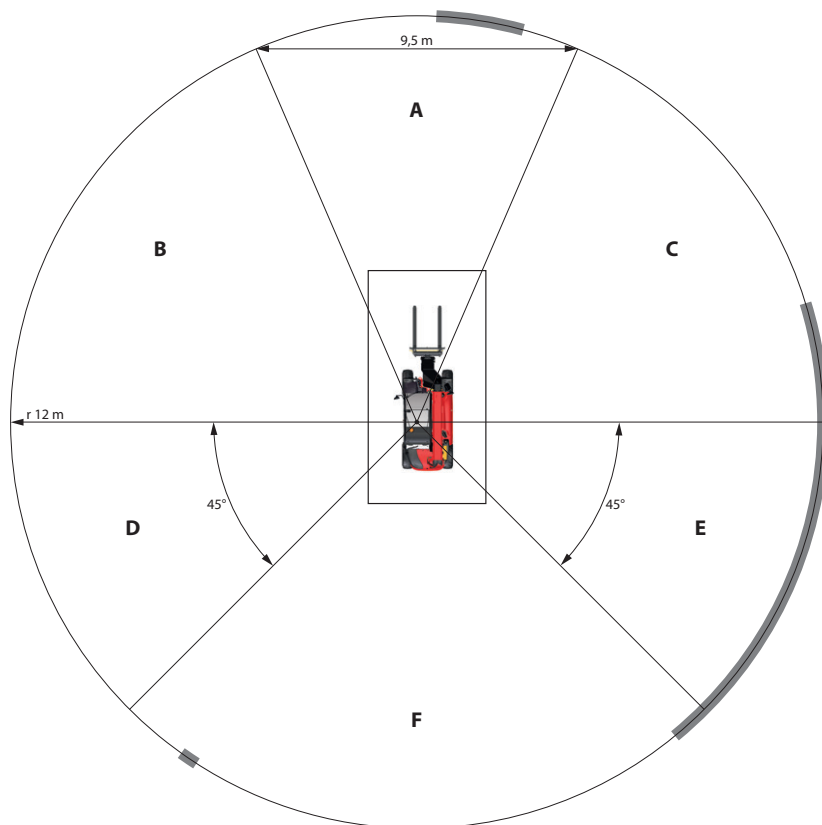

# INSTRUMENTS AND CONTROLS

## DESCRIPTION

NOTE: All the terms such as: RIGHT, LEFT, FRONT, REAR are as seen by an observer occupying the driver's seat and looking straight ahead.

1 - DRIVER'S CAB ACCESS .....	2-26
2 - SEAT BELT .....	2-26
3 - DRIVER'S SEAT .....	2-27
4 - IGNITION SWITCH .....	2-29
5 - EMERGENCY STOP .....	2-29
6 - BATTERY CUT-OFF .....	2-29
7 - BATTERY .....	2-29
8 - MAN-MACHINE INTERFACE (MMI) .....	2-30
9 - LONGITUDINAL STABILITY LIMITER AND WARNING DEVICE .....	2-34
10 - SWITCHES .....	2-36
11 - ARMREST AND STORAGE .....	2-37
12 - DIAGNOSTIC PLUG .....	2-37
13 - FUSES AND RELAYS .....	2-38
14 - CIGARETTE LIGHTER .....	2-40
15 - LIGHTING, HORN AND INDICATOR SWITCH .....	2-40
16 - FRONT AND REAR WINDSCREEN WIPER SWITCH .....	2-40
17 - FUNCTION FILES .....	2-40
18 - HYDRAULIC CONTROLS .....	2-41
19 - SPEED SELECTOR .....	2-42
20 - ACCELERATOR PEDAL .....	2-43
21 - SERVICE BRAKE PEDAL AND TRANSMISSION CUT-OFF .....	2-43
22 - FORWARD/NEUTRAL/REVERSE GEAR SELECTION .....	2-43
23 - STEERING SELECTION .....	2-44
24 - HEATER CONTROL .....	2-45
25 - AIR CONDITIONING CONTROLS (AIR CONDITIONING OPTION) .....	2-45
26 - HEATING VENTS .....	2-46
27 - DEMIST VENTS .....	2-46
28 - LEVEL INDICATOR .....	2-46
29 - DOOR LOCK .....	2-46
30 - DOOR WINDOW OPENING HANDLE .....	2-46
31 - DOOR WINDOW RELEASE BUTTON .....	2-46
32 - HANDLE FOR REAR WINDOW OPENING .....	2-46
33 - DOCUMENT STORAGE NET .....	2-46
34 - STEERING WHEEL ADJUSTMENT LEVER (OPTION) .....	2-46
35 - FRONT HEADLIGHTS .....	2-47
36 - REAR LIGHTS .....	2-47
37 - ROTATING BEACON LIGHT .....	2-47
38 - ROOF LIGHT (OPTION) .....	2-47
39 - ROOF-SIDE WINDSCREEN WIPER SWITCH (OPTION) .....	2-47
40 - SUN VISOR (OPTION) .....	2-47
41 - BOOM SAFETY WEDGE .....	2-48
42 - FUEL TANK .....	2-48



## 1 - DRIVER'S CAB ACCESS

Use the contact points 1 to get into or out of the driver's cab.

- Mounting at the front.
- Descending at the rear.



## 2 - SEAT BELT

### **⚠ IMPORTANT ⚠**

*In no event should the lift truck be used if the seat belt is defective (fixing, locking, cuts, tears, etc.).  
Repair or replace the seat belt immediately.*

- Sit correctly on the seat.
- Check that seat belt is not twisted.
- Place the seat belt at hip level.
- Attach the seat belt and check that it locks.
- Adjust the seat belt to your body shape without compressing your pelvis and without excessive slack.



### 3 - DRIVER'S SEAT

DESIGNED FOR MAXIMUM COMFORT, THIS SEAT CAN BE ADJUSTED AS FOLLOWS.

#### WEIGHT ADJUSTMENT

Adjust the weight when the driver is sitting on the seat.

- Pull the weight adjustment lever 1 fully out.
- Move the weight adjustment lever 1 up to increase the weight or down to reduce it.
- There are ten possible positions between the min and max weights. Before each run, return the lever to the central position. The max. or min. position is indicated by a freely travelling lever.
- The driver's weight is correctly adjusted when the arrow is in the centre of indicator 2.
- After completing weight adjustment, fully lower the lever 1.

NOTE: To avoid any health problems, it is recommended that the weight setting is checked and adjusted before starting the lift truck.

#### LONGITUDINAL ADJUSTMENT

- Adjust the locking lever until you reach the position required. This then locks and the seat will not shift into another position.

**⚠ IMPORTANT ⚠**

*Only operate the lever by its recessed section and do not grasp from below, at the risk of crushing the hand.*

#### LUMBAR ADJUSTMENT

This increases the comfort of the seat and the driver's freedom of movement.

- Turn knob to 1 to adjust the height and depth of the lumbar support of the upper part of the back-rest.
- Turn knob to 2 to adjust the height and depth of the lumbar support of the lower part of the back-rest.

#### BACK-REST ANGLE ADJUSTMENT

- Support the back-rest, pull the lever and position the back-rest to find the desired position.

**⚠ IMPORTANT ⚠**

*If you do not support the back rest when making adjustments, it will tilt forwards.*

#### MAINTENANCE

Dirt may adversely affect the correct functioning of the seat. For this reason, make sure your seat is always clean.

- The cushions do not require to be removed from the seat frame for cleaning.

**⚠ IMPORTANT ⚠**

*Accident risks are increased when the back-rest tilts*

First check the resistance of the fabric on a small concealed area before using any fabric and plastic cleaner.

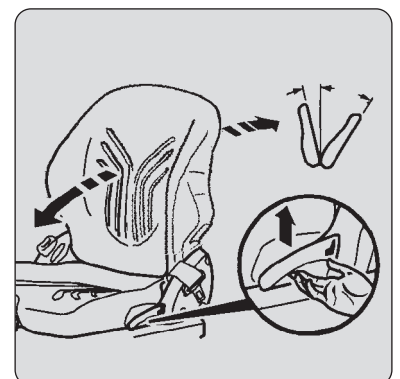
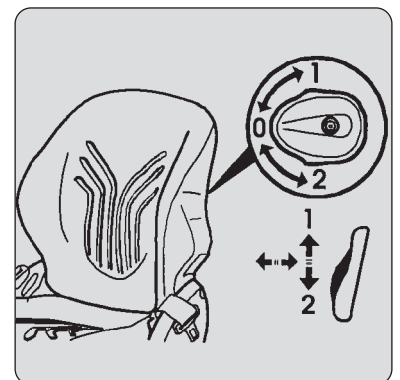
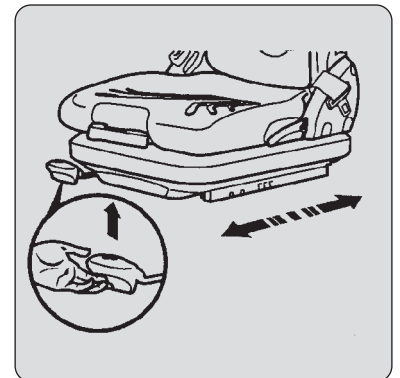
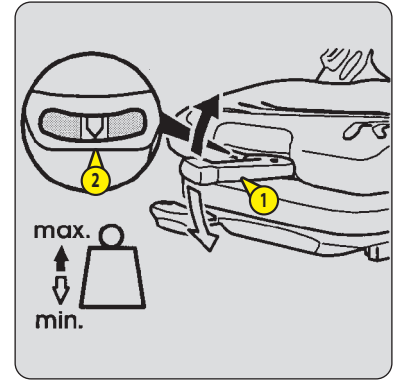

## DRIVER'S SEAT (OPTION)

DESIGNED FOR MAXIMUM COMFORT, THIS SEAT CAN BE ADJUSTED AS FOLLOWS.

### WEIGHT AND SEAT HEIGHT ADJUSTMENT

Adjust the weight when the driver is sitting on the seat.

- Switch on lift truck ignition.
- Move the weight adjustment lever 1 upwards to increase the weight or downwards to reduce it.
- The min and max weight can be set by engaging the upper or lower limit switch.
- The driver's weight is correctly adjusted when the arrow is in the centre of indicator lamp 2.
- The seat height can be adjusted within this zone.

NOTE: To avoid any health problems, it is recommended that the weight setting is checked and adjusted before starting the lift truck.

#### ⚠ IMPORTANT ⚠

*To avoid causing any damage, do not activate the compressor for over 1 minute.*

### LONGITUDINAL ADJUSTMENT

- Adjust the locking lever until you reach the position required. This then locks and the seat will not shift into another position.

#### ⚠ IMPORTANT ⚠

*Only operate the lever by its recessed section and do not grasp from below, at the risk of crushing the hand.*

### LUMBAR ADJUSTMENT

This increases the comfort of the seat and the driver's freedom of movement.

- Turn the handle to 1 to adjust the height and depth of the lumbar support of the upper part of the back-rest.
- Turn the handle to 2 to adjust the height and depth of the lumbar support of the lower part of the back-rest.

### BACK-REST ANGLE ADJUSTMENT

- Support the back-rest, pull the lever and position the back-rest to find the desired position.

#### ⚠ IMPORTANT ⚠

*If you do not support the back rest when making adjustments, it will tilt forwards.*

### MAINTENANCE

Dirt may adversely affect the correct functioning of the seat. For this reason, make sure your seat is always clean.

- The cushions do not require to be removed from the seat frame for cleaning.

#### ⚠ IMPORTANT ⚠

*Accident risks are increased when the back-rest tilts*

First check the resistance of the fabric on a small concealed area before using any fabric and plastic cleaner.

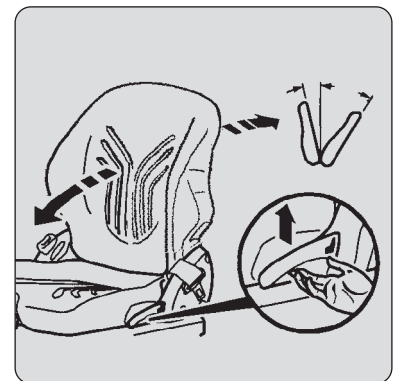
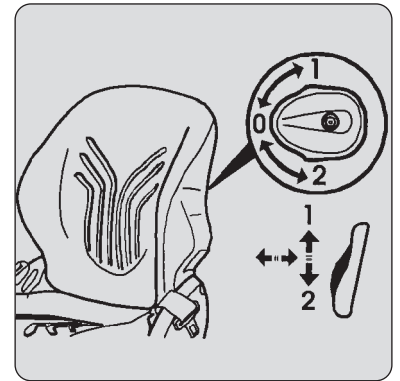
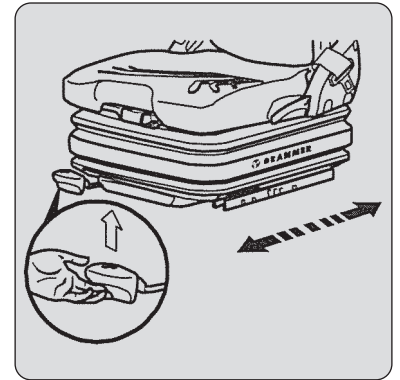
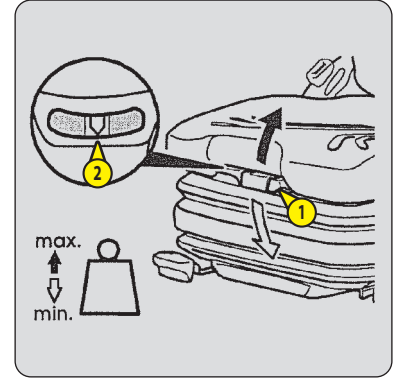

## 4 - IGNITION SWITCH

This switch has 5 positions:

- P - Not used.
- O - Ignition switched off and engine stopped.
- I - Ignition + preheat.
- II - Not used.
- III - Start-up and returns to position I as soon as the key is released.

## 5 - EMERGENCY STOP

In the event of danger, it enables the engine to be shut down, thereby cutting-off all hydraulic movements.

### **⚠ IMPORTANT ⚠**

*Warning, hydraulic movements suddenly stop when using this button.  
If possible, stop the lift truck before using the emergency stop.*

- Turn the knob to deactivate it before restarting the lift truck.



## 6 - BATTERY CUT-OFF

For quickly disconnecting the battery when working on the electric circuit or when soldering, for example.

### **⚠ IMPORTANT ⚠**

*Operate the battery cut-out no less than 30 seconds after having switched off the ignition with the ignition key.*



## 7 - BATTERY



## 8 - MAN-MACHINE INTERFACE (MMI)

- A - INSTRUMENT CONTROL PANEL
- B - SCREEN DISPLAYS

### A - INSTRUMENT CONTROL PANEL

#### **⚠ IMPORTANT ⚠**

*A permanently lit or flashing warning lamp, with the engine running, is the sign of an operating fault. The lighting of some lamps may be accompanied by an audible signal. Do not ignore this warning, consult your dealer without delay. If one of the warning lamps comes on while the lift truck is in motion, stop the lift truck under the safest possible conditions.*



#### **REV COUNTER**

10 level LED display from 0 to 3000 rpm.



#### **ENGINE WATER TEMPERATURE**

Temperature zones:

- 1 LED - (< 40 °C) zone. Use the lift truck with moderation, wait for temperature to increase before normal operation.
- 2 LEDs - (40 °C - 60 °C) zone.
- 3 LEDs - (60 °C - 80 °C) zone.
- 4 LEDs - (80 °C - 85 °C) zone.
- 5 LEDs - (85 °C - 90 °C) zone.
- 6 LEDs - (90 °C - 95 °C) zone from 40 °C to 95 °C use the lift truck normally.
- 7 LEDs - (95 °C - 105 °C) zone. Use the lift truck with moderation.
- 8 LEDs - (105 °C - 110 °C) zone. Use the lift truck with moderation, ventilation control operating at full speed.
- 9 LEDs - Red zone (110 °C - 115 °C).
- 10 LEDs - Red zone (> 115 °C) Stop the lift truck, seek the cause of overheating.

NOTE: If the red indicator lamp  and the buzzer come on (> 110 °C) when the lift truck is running, stop the engine immediately and seek the cause of the failure in the cooling system.



#### **FUEL LEVEL**

When only one LED is still displayed, the indicator lamp  comes on, indicating that you are using the reserve fuel supply and that your operating time is limited.



#### **FORWARD/NEUTRAL/REVERSE INDICATOR**

◀ 2 - DESCRIPTION: FORWARD/NEUTRAL/REVERSE GEAR SELECTION.



#### **AIR FILTER CLOGGING WARNING INDICATOR LAMP**

The indicator lamp and buzzer come on when the air filter cartridge is clogged. When this indicator lamp remains on continuously the cartridge needs changing. Stop the engine and carry out the necessary repairs (◀ 3 - MAINTENANCE: FILTER ELEMENTS AND BELTS).



#### **HYDRAULIC OIL FILTER CLOGGING WARNING INDICATOR LAMP**

The lamp and the buzzer come on when the hydraulic return oil filter cartridge is clogged up. Stop the engine and carry out the necessary repairs (◀ 3 - MAINTENANCE: FILTER ELEMENTS AND BELTS).



#### **GENERAL FAULT WARNING INDICATOR LAMP**

If the lamp and the buzzer come on when the lift truck is running, stop the engine immediately and consult your dealer.



#### **TRANSMISSION OIL TEMPERATURE WARNING INDICATOR LAMP**

The lamp and the buzzer come on when the transmission oil temperature is abnormally high. Stop the lift truck and seek the cause of this overheating.



### **ENGINE FAULT INDICATOR LAMP**

If the indicator lamp comes on or flashes while the lift truck is in operation, a diagnostic fault has been detected. The lift truck will operate in reduced mode. Consult your dealer without delay.

### **FUEL LEVEL FAULT INDICATOR LAMP** ( **FUEL LEVEL**)

### **BATTERY CHARGE WARNING INDICATOR LAMP**

If the lamp and the buzzer come on when the lift truck is running, stop the engine immediately and seek the cause (electric circuit, alternator belt, alternator, etc.).

### **AUTOMATIC EXHAUST PURIFICATION DEACTIVATED INDICATOR LAMP**

The indicator lamp comes on when the lift truck is running to indicate that the automatic exhaust purification is disabled ( Switches - Exhaust purification).

### **HIGH EXHAUST GAS TEMPERATURE INDICATOR LAMP**

The indicator lamp comes on while the lift truck is operating to indicate a high exhaust gas temperature. You can continue to use the lift truck ( Switches - Exhaust purification).

### **SOOT LEVEL INDICATOR LAMP**

The indicator lamp comes on while the lift truck is operating to indicate the soot level ( Switches - Exhaust purification).

### **"STATIONARY LIFT TRUCK" EXHAUST PURIFICATION INDICATOR LAMP**

The indicator lamp comes on while the lift truck is operating, indicating a "stationary lift truck" exhaust purification is in progress ( 3 - MAINTENANCE: OCCASIONAL SERVICE - "Stationary lift truck" exhaust purification).

### **ENGINE OIL PRESSURE WARNING INDICATOR LAMP**

If the indicator lamp and the buzzer come on when the lift truck is operating, stop the engine immediately and look for the cause ( 3 - MAINTENANCE: Engine oil level).

### **ENGINE WATER TEMPERATURE INDICATOR LAMP** ( **ENGINE WATER TEMPERATURE**)

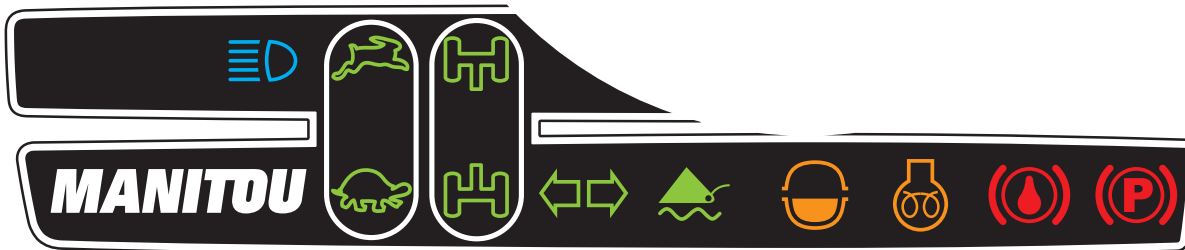

**(P) PARKING BRAKE FAULT INDICATOR LAMP**

The indicator lamp comes on when the parking brake is applied (↔ SWITCHES).

**(🔴) BRAKING OIL LEVEL WARNING INDICATOR LAMP**

If the lamp comes on when the lift truck is running, stop the engine immediately and check the brake fluid level. In the event of an abnormal drop in the level, consult your dealer.

**(🔴) ENGINE PREHEAT FAULT INDICATOR LAMP**

If preheating is required, the lamp comes on when the lift truck's ignition is switched on and should go out as soon as preheating is ended. If this lamp comes on while the lift truck is in operation, immediately stop the engine and seek the cause.

**(🔴) WATER IN FUEL PRE-FILTER WARNING INDICATOR LAMP**

The indicator lamp will come on when there is water in the fuel pre-filter. Stop the lift truck and carry out the necessary repairs (↔ 3 - MAINTENANCE: CLEAN Fuel pre-filter).

**(🟢) NOT USED**

**(↔) INDICATOR LIGHTS INDICATOR LAMP**

**(🏠) FRONT WHEEL ALIGNMENT INDICATOR LAMP**

**(🏠) REAR WHEEL ALIGNMENT INDICATOR LAMP**

**(🐎) FAST GEAR INDICATOR LAMP**

**(🐎) SLOW GEAR INDICATOR LAMP**

**(💡) BLUE MAIN BEAM HEADLIGHTS INDICATOR LAMP**

**B - SCREEN DISPLAYS**



UPPER SCREEN DISPLAY

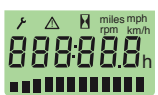

LOWER SCREEN DISPLAY

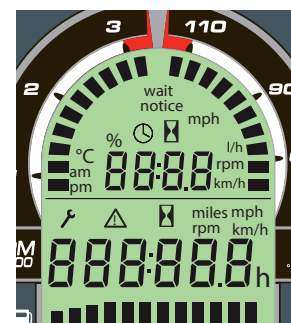

SCROLL BUTTON



VALIDATION, RESET AND ERROR CODE BUTTON

**UPPER SCREEN DISPLAY**

Switch on the lift truck ignition, by default, the screen will show the time. Press the scroll button to switch from one screen to the other in turn.

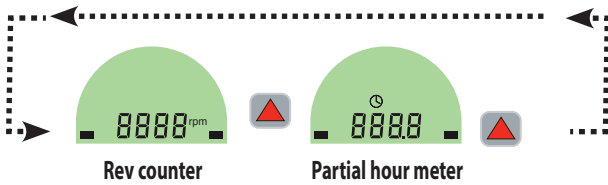

**SETTING THE TIME**

- Display clock screen.
- Press the button for 2 seconds, choose the "24 hour" or "12 hour am/pm" clock with the button and confirm .
- Set the hours with the button and confirm .
- Set the minutes with the button and confirm .

**RESETTING THE PARTIAL HOUR METER**

- Display the partial hour meter screen.
- Press the button for 2 seconds, resetting is confirmed by an audible signal.

**LOWER SCREEN DISPLAY**



Switch on the lift truck ignition, by default, the screen will show the hour meter , i.e. the total number of hours the lift truck has been used. As soon as the engine is running, the flashing pictogram is displayed and the hour meter records the hours of operation.

**MAINTENANCE INTERVAL**

NOTE: When the new lift truck is started, the maintenance key will logically be displayed to provide a reminder to replace the engine oil and the oil filter after the first 50 hours of operation (←: 3 - MAINTENANCE: SERVICING SCHEDULE).



The maintenance key appears on the hour meter screen 50 hours before the maintenance deadline and generates an audible signal.



- Press the button to display the time remaining before maintenance . In the event that the deadline is exceeded, the hours are shown with a plus sign.
- Press once more on the button to return to the hour meter screen. The maintenance key will be displayed for information.
- Contact your dealer to carry out the necessary maintenance operations and reset the maintenance interval.

NOTE: The frequency interval displayed by default is 500 hours; this interval can be modified. Please contract your dealer.

**ERROR CODES**

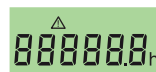

The appearance of the pictogram on the hour meter screen together with an audible signal, indicate that a fault has been detected by one of the lift truck's Electronic Control Units (ECU).



- Press the button to display the information on the upper screen, as well as the error code .
- If there are several error codes, press the button to scroll through all the error codes.
- Press the button again to return to the hour meter screen; the pictogram will remain displayed as long the as the required repairs have not been carried out.
- Contact your dealer, stating the error code or codes.

NOTE: A faulty fuse can generate several error codes. When "error codes" and "maintenance interval" are displayed together, the maintenance reminder time will appear at the end of the list.

## 9 - LONGITUDINAL STABILITY LIMITER AND WARNING DEVICE

### ⚠ IMPORTANT ⚠

The operator must respect the lift truck's load chart, and the operating mode according to the attachment.

This device warns the operator of the lift truck's longitudinal stability limits. However, lateral stability can reduce the load chart in the upper part, and this reduction is not detected by the device.

Depending on the type of work required, the longitudinal stability limiter and warning device allows the operator to operate the lift truck in complete safety.

UPDATE: To gain maximum advantage from the longitudinal stability limiter and warning device of your lift truck, contact your dealer to receive the latest version of the software available.

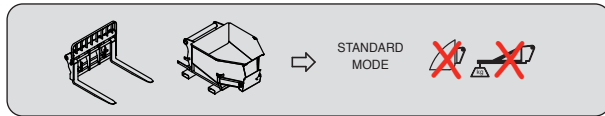
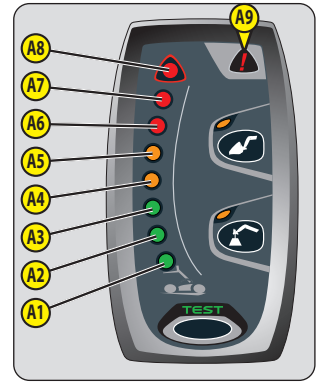

### "HANDLING" MODE

#### USE ON FORKS

- By default, the device is in "HANDLING MODE" each time the lift truck is started.
- Protection against tilting forwards during aggravating movements is guaranteed, except when the telescope is retracted.

STATUS OF THE DEVICE			
HALTED	SLOW SPEED 1 to 5 km/h	SPEED > 5 km/h	BOOM RETRACTED (★)
A4-A5: Very slow intermittent sound alarm. A6: Slow intermittent sound alarm. A7: Fast intermittent sound alarm. A8: Very fast intermittent sound alarm.	A7: Fast intermittent sound alarm. A8: Very fast intermittent sound alarm.	-No sound alarm.	-No sound alarm. -Indicator lamp A9  on.

(★) FOR AUSTRALIA: Boom extension of 1 meter maximum and boom lift angle of 10° maximum. Regularly check that the indicator light works correctly under these conditions (⚠ MAINTENANCE: OCCASIONAL MAINTENANCE).

NOTE: When A9 is ON, it warns operator that the cut-off movement function is disabled (overriden).

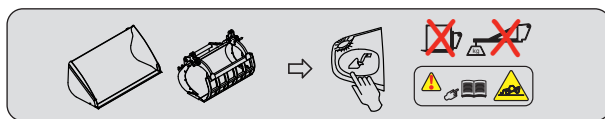

### "BUCKET" MODE

#### USE WITH BUCKET

- Place the lift truck in the transport position.
- Hold down the button, "BUCKET" MODE is confirmed by a sound signal and the indicator lamp coming on.
- Press this button again or switch off the ignition with the ignition key to return to "HANDLING" MODE.
- Protection against tilting forwards during aggravating movements is guaranteed, except when the telescope is retracted.

STATUS OF THE DEVICE			
HALTED	SLOW SPEED 1 to 5 km/h	SPEED > 5 km/h	BOOM RETRACTED (★)
-The "BUCKET" mode deactivates automatically if the lift truck remains stationary.	A6: An audible signal upon passing into the red zone. -The hydraulic movements are adapted.	-No sound alarm. -The hydraulic movements are adapted.	-No sound alarm. -Indicator lamp A9  on.

(★) FOR AUSTRALIA: Boom extension of 1 meter maximum and boom lift angle of 10° maximum. Regularly check that the indicator light works correctly under these conditions (⚠ MAINTENANCE: OCCASIONAL MAINTENANCE).

NOTE: When A9 is ON, it warns operator that the cut-off movement function is disabled (overriden).

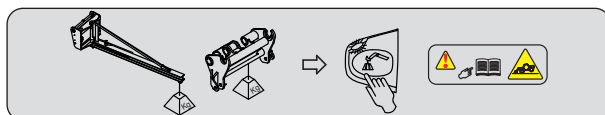



### "SUSPENDED LOAD" MODE

#### USE WITH LIFTING DEVICE (offering a higher margin of safety)

- Place the lift truck in the transport position.
- Press the button, the "SUSPENDED LOAD" MODE is confirmed by a sound signal and the indicator lamp coming on. Hydraulic tilting movements are neutralised, as well as the lifting movement when the longitudinal stability limit is reached (indicator lamp A8 lit).
- Press this button again or switch off the ignition with the ignition key to return to "HANDLING" MODE.

- Protection against tilting forwards during aggravating movements is guaranteed, except when the telescope is retracted.

STATUS OF THE DEVICE			
HALTED	SLOW SPEED 1 to 5 km/h	SPEED > 5 km/h	BOOM RETRACTED (★)
	A4-A5: Very slow intermittent sound alarm. A6: Slow intermittent sound alarm. A7: Fast intermittent sound alarm. A8: Very fast intermittent sound alarm.		-No sound alarm. -Indicator light A9 on. 

(★) FOR AUSTRALIA: Boom extension of 1 meter maximum and boom lift angle of 10° maximum. Regularly check that the indicator light  works correctly under these conditions (↩ MAINTENANCE: OCCASIONAL MAINTENANCE).

NOTE: When A9 is ON, it warns operator that the cut-off movement function is disabled (overriden).

#### A - VISUAL ALARMS

- A1 - A2 - A3: There is a significant reserve of longitudinal stability.
- A4 - A5: The lift truck is approaching the limit of longitudinal stability, move with care.
- A6: The lift truck is close to the longitudinal stability limit. Manoeuvre with care.
- A7: The lift truck is very close to the longitudinal stability limit. Manoeuvre with extreme caution.
- A8: The lift truck is at the authorised longitudinal stability limit.
- A9: The "AGGRAVATING" hydraulic movement cut-off is disabled.

- The warning indicator lamp  accompanied by a sound alarm indicates a fault. To view this error code (↩ SCREEN DISPLAYS).

#### B - HYDRAULIC MOVEMENT CUT-OFF

(★) FOR AUSTRALIA: Boom extension of 1 meter maximum and boom lift angle of 10° maximum. Regularly check that the indicator light  works correctly under these conditions (↩ MAINTENANCE: OCCASIONAL MAINTENANCE).

##### "HANDLING" MODE

- A8: All "AGGRAVATING" hydraulic movements are cut off. Only perform de-aggravating hydraulic movements in the following order: retract and raise the boom.

##### "BUCKET" MODE

- A8: The boom lowering and extension movements are cut off, the other movements remain available.

##### "SUSPENDED LOAD" MODE

- A8: All "AGGRAVATING" and boom raising hydraulic movements are cut-off. Only the boom retraction hydraulic movement is available.

#### C - DISABLING "AGGRAVATING" HYDRAULIC MOVEMENT CUT-OFF

##### **IMPORTANT**

*Remain very vigilant during this operation. The only information available to the operator is the lift truck's dynamic stability.*

In certain cases, in order to get out of a difficult situation, the operator can bypass this safety device. Button C temporarily disables the cut-off of "AGGRAVATING" hydraulic movements.



- Hold down button C, indicator lamps A9 and C1 will light (60 second time delay), and at the same time perform the necessary "AGGRAVATING" hydraulic movement with extreme care.

#### D - TESTING THE LONGITUDINAL STABILITY LIMITER AND WARNING DEVICE

- Press briefly on the  button at any time to verify that the longitudinal stability alarm is working.
  - Correct operation: All the LEDs A1 to A8 light for two seconds and an audible alarm is sounded.

NOTE: This test does not make it possible to check the correct adjustment of the longitudinal stability limiter device which must be inspected daily or after every 10 hours of service (↩ 3 - MAINTENANCE: 10H - DAILY SERVICE OR EVERY 10 HOURS SERVICE).

#### E - STRAIN GAUGE







##### **IMPORTANT**

*Disassembly or calibration of the strain gauge is prohibited, this must only be done by specially trained personnel, consult your dealer.*



## 10 - SWITCHES

NOTE: The location of the switches may vary depending on the options.

-  **HAZARD WARNING LIGHTS**
-  **REAR FOG LIGHT (OPTION)**
-  **ROTATING BEACON LIGHT (OPTION)**
-  **FRONT AND REAR WORKING LIGHTS (OPTION)**
-  **REAR WINDOW DEFROSTER (OPTION)**
-  **HYDRAULIC MOVEMENT NEUTRALISATION**



When driving on the road, it is highly recommended (mandatory in Germany) that you cut-off all the hydraulic movements. The indicator lamp shows when it is in use.

### "LIFT TRUCK STATIONARY" EXHAUST PURIFICATION



↖ 3 - MAINTENANCE: OCCASIONAL MAINTENANCE













### AUTOMATIC EXHAUST PURIFICATION DEACTIVATION

#### **⚠ IMPORTANT ⚠**

*Disabling the automatic exhaust purification remains a function that is only to be used in case of necessity (confined or unventilated space, etc.).*

By default, the automatic exhaust purification is activated each time the lift truck is started.

- To deactivate the automatic exhaust purification, hold down the bottom of the switch. The indicator lamp  lights up and an audible signal confirms deactivation.
- To reactivate the automatic exhaust purification hold down the bottom of the switch again. The  indicator lamp goes out to confirm reactivation.

EXHAUST PURIFICATION MANAGEMENT			
INDICATIONS	ACTIONS		
 + 1 short sound alarm. Moderate soot level.	Indicator lamp  comes on. Preferably wait until automatic purification is completed before switching off the ignition.	Or	Activate "lift truck stationary" exhaust purification (↖ 3 - MAINTENANCE: OCCASIONAL MAINTENANCE).
 +  + 1 short sound alarm. Moderate soot level, automatic purification disabled.	Enable automatic purification as soon as possible.	Or	Activate "lift truck stationary" exhaust purification (↖ 3 - MAINTENANCE: OCCASIONAL MAINTENANCE).
 +  + permanent sound alarm. High soot level.	Engine speed limited to 1200 rpm, only a "stationary lift truck" purification must be performed (↖ 3 - MAINTENANCE: OCCASIONAL MAINTENANCE).		
 +  +  + permanent sound alarm. Moderate soot level, automatic purification disabled.			
 +  +  + 1 short sound alarm. Very high soot level, particle filter clogged.	<b>Reduced lift truck efficiency, shut down the lift truck and contact your dealer.</b>		

## **PARKING BRAKE**

To connect the parking brake, press the bottom of the switch. The indicator lamp indicates when it is in use. To disconnect the parking brake, press the top of the switch.

## **DISABLING "AGGRAVATING" HYDRAULIC MOVEMENT CUT-OFF**

<img alt="Arrow icon" data-bbox="72 138 88 152"/> LONGITUDINAL STABILITY LIMITER AND WARNING DEVICE

## **ATTACHMENT HYDRAULIC LOCKING (OPTION) MT 420 H 57K ST5 S1**

OR

**BOOM HEAD ELECTROVALVE (OPTION)**

OR

**BOOM HEAD ELECTROVALVE + ATTACHMENT HYDRAULIC LOCKING (OPTION)**

<img alt="Arrow icon" data-bbox="72 256 88 270"/> DESCRIPTION AND USE OF THE OPTIONS

## **ATTACHMENT HYDRAULIC CONTROL FORCED OPERATION (OPTION)**

<img alt="Arrow icon" data-bbox="72 300 88 314"/> DESCRIPTION AND USE OF THE OPTIONS

## **BOOM ELECTRICAL PREDISPOSITION (OPTION)**

<img alt="Arrow icon" data-bbox="72 345 88 359"/> DESCRIPTION AND USE OF THE OPTIONS

## **TILTING MOVEMENT NEUTRALISATION (OPTION)**

Makes it possible to cut off the carriage excavating and dumping movements. The indicator lamp shows when it is in use.



## 11 - ARMREST AND STORAGE

- Lift the armrest 1 to access the storage.



## 12 - DIAGNOSTIC PLUG

- Remove the access panel to access the plugs.



### 13 - FUSES AND RELAYS

A sticker on the inside of the access panel provides a quick indication of the use of the fuse plate's components described below.

- Remove access panel 1 to gain access to the fuses and relays. Replace a used fuse with a new fuse of the same quality and capacity. Never reuse a repaired fuse.

#### IN THE CAB

F1	5A	Control instrument module.
F2	5A	Alternator excitation. Longitudinal stability limiter and warning device. ECM wake-up.
F3	5A	Diagnostics plug. Anti-theft device predisposition.
F4	10A	Transmission electronic control unit. Telescoping and attachment movement control. Negative parking brake electrovalve.
F5	10A	12 V connector.
F6	5A	Presence of driver on seat. Retraction and boom angle sensors.
F7	10A	Hydraulics electronic control unit power supply.
F8	10A	Deactivation of aggravating hydraulic movement cut-off. OPTION Boom head electrovalve.
F9	15A	Brake light relay power supply. Reversing light relay power supply. Audible reversing alarm relay power supply.
F10	2A	Wheel alignment.
F11	15A	Flashing unit.
F12	5A	Rear fog lights.
F13	15A	Working lights on boom switch (OPTION).
F14	7,5A	Rotating beacon light.
F15	10A	Rear windscreen defrost.
F16	15A	Self-cleaning fan.
F17	15A	Rear windscreen wiper and windscreen washer.
F18	15A	Front windscreen wiper and windscreen washer.
F19	7,5A	Boom head electric power socket (OPTION). Cameras (OPTION).
F20	10A	Heating.
F21	3A	Left sidelights.
F22	3A	Right sidelights.
F23	15A	Dipped beam headlights.
F24	15A	Main beam headlights.
F25	7,5A	Right indicator lights.
F26	7,5A	Left indicator lights.
F27	5A	Starter relay power supply.
F28	3A	Car radio.
F29	10A	Pneumatic seat (OPTION).
F30	20A	Front and rear working lights.
F31	20A	Lighting, horn and indicator switch
F32	15A	Hazard warning lights (K4).
F33	5A	Diagnostic plug (+) permanent. Anti-theft device predisposition (+) permanent.
F34	7,5A	Warning device. OPTION Roof light.
F35	10A	Car radio (+) permanent
F36	5A	Power supply + Main ECU SPU 40-26.
F37	10A	Power supply + RAZ bat EG rear engine
F38	15A	Power supply + RAZ bat EG rear engine
F39		Free.
F40		Free.
F41	20A	Engine ECU
F42	60A	Ignition switch.
F43	30A	Power supply K22.
	50A	Power supply K22 + diesel decongealant (OPTION).
F44	50A	Fuse power supply (F31 to F40).
F45	20A	Engine start-up.
F46	30A	Air conditioning (OPTION).

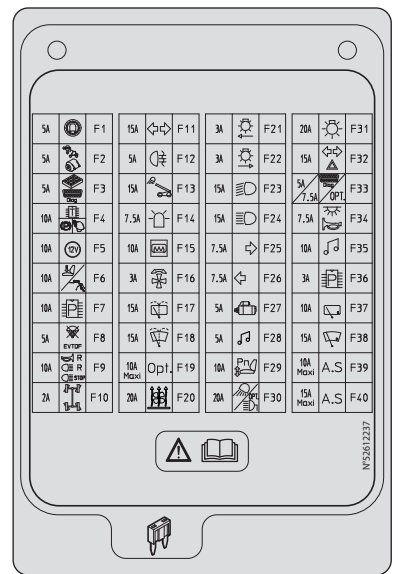

K1		Free.
K2		Reversing lights. Reversing sound alarm (OPTION).
K3		Brake lights.
K4		Working lights on boom (OPTION).
K5		Blue working lights (OPTION).
K6		Free.
K7		Heating.
K8		Flashing unit.
F61	2A	Control instrument module battery (+) power supply
F62	2A	Anti-theft device predisposition (+) permanent
F63	10A	Computer supply
F64	10A	Computer supply

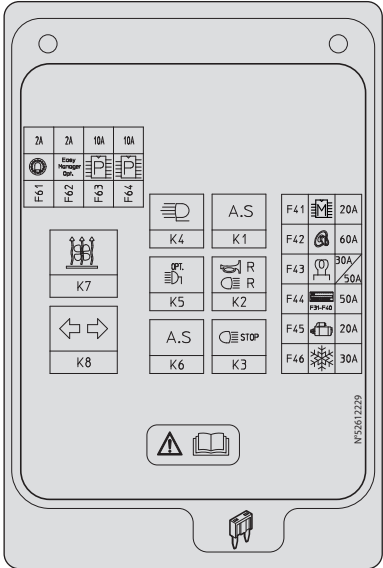

**IN THE ENGINE COMPARTMENT**

- Open the engine cover 1 in order to gain access to the fuses and relays. Replace a used fuse with a new fuse of the same quality and capacity. Never reuse a repaired fuse.

K21		Engine ECU control
K22		Engine preheat
K23		Starter control
F50	3A	Alternator
F51	5A	Presence of water in diesel sensor + ECU wake-up.
F52	3A	Flow meter
F53	5A	EGR Valve
F54	3A	Dashboard power supply.

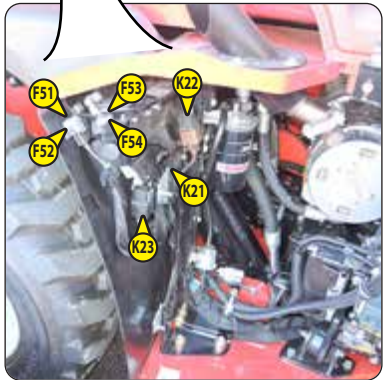

**UNDER THE CASING**

**FUSE**

F55	3A	Dashboard power supply.
-----	----	-------------------------



## 14 - CIGARETTE LIGHTER

For 12 V appliance and max. amperage 15A.

## 15 - LIGHTING, HORN AND INDICATOR SWITCH

The switch controls the visual and sound alarms.

- A - All lights are off, the indicator lights do not flash.
- B - The right hand indicator lights flash.
- C - The left hand indicator lights flash.
- D - Sidelights and rear lights on.
- E - The dipped headlights and the rear lights are on.
- F - The main beam headlights and the rear lights are on.
- G - Headlight signalling.

Pressing the end of the switch sounds the horn.

NOTE: Positions D - E - F - G can be used without switching on the ignition.

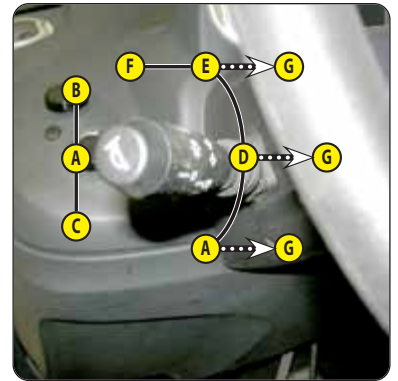

## 16 - FRONT AND REAR WINDSCREEN WIPER SWITCH

FRONT WINDSCREEN WIPER

- A - Front windscreen wiper stop.
- B - Front windscreen wiper low speed.
- C - Front windscreen wiper high speed.
- D - Front windscreen wiper intermittent.
- E - Front windscreen washer by pressing.

REAR WINDSCREEN WIPER

- F - Rear windscreen wiper stop.
- G - Rear windscreen wiper.
- H - Rear windscreen washer by pressing.

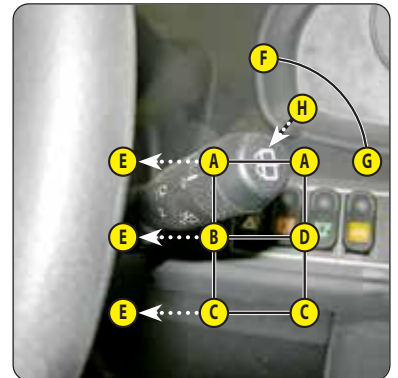

## 17 - FUNCTION FILES

These files contain, among other things, the description of the hydraulic controls and the load charts for the attachments used on the lift truck.

## 18 - HYDRAULIC CONTROLS

### ⚠ IMPORTANT ⚠

**Do not attempt to alter the hydraulic system pressure by interfering with the pressure regulating valve. In the event of suspected malfunction, contact your dealer. ANY ALTERATION MAY RENDER THE WARRANTY NULL AND VOID.**

**Use the hydraulic controls gently without jerking, to avoid incidents caused by shaking the lift truck.**

NOTE: When driving on the road, it is highly recommended (mandatory in Germany) that all the hydraulic movements are cut off (☞ SWITCHES).

### HYDRAULIC CONTROLS ACTIVATION

To avoid inadvertent operation of the hydraulic lifting, tilting, telescoping and attachment controls, a safety device is added to the lift truck (SECOND FIT).

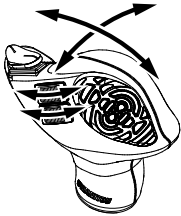
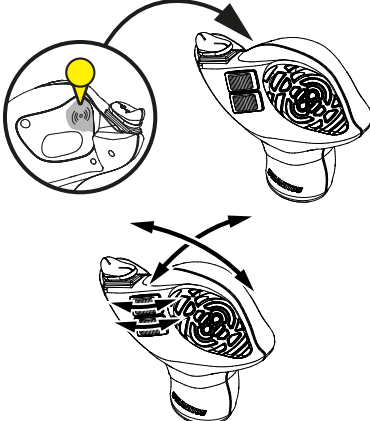
FIRST FIT: NO HYDRAULIC CONTROLS ACTIVATION	
	<p>- Place your hand on the lever and perform the hydraulic movement.</p>
SECOND FIT: HYDRAULIC CONTROLS ACTIVATION	
	<p>- Place your hand on the lever, activate the hydraulic controls by contact on the capacitive sensor and perform the hydraulic movement.</p>
<p>- Hydraulic controls activation is maintained on a timer while the lift truck is being used. - If necessary, reactivate the hydraulic controls.</p>	

**A1 - LIFTING**

**A2 - LOWERING**

**B1 - EXCAVATION**

**B2 - DUMP**

**C1 - TELESCOPE EXTENSION**

**C2 - TELESCOPE RETRACTION**

**D1 - ATTACHMENT**

**D2 - ATTACHMENT**



**E - BOOM HEAD ELECTROVALVE (OPTION)**

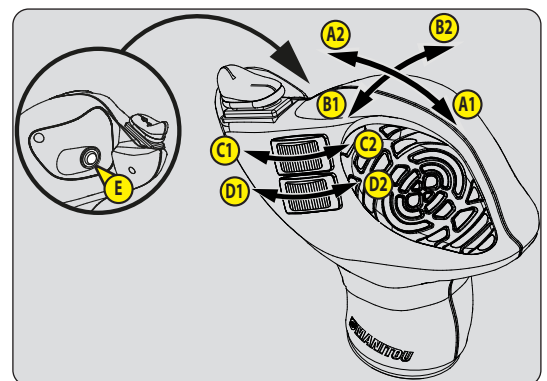

☞ DESCRIPTION AND USE OF THE OPTIONS ADJUSTMENT OF ATTACHMENT HYDRAULIC FLOW RATE



**ADJUSTMENT OF ATTACHMENT HYDRAULIC FLOW RATE**

- Switch on lift truck ignition.

- Select the attachment circuit hydraulic flow screen  with the scroll button . In turn the screen displays the hydraulic flow stored in the memory of circuit B (without "-" sign) and of circuit A (with "-" sign).

- Press the  button for two seconds, the screen  will appear on the lower screen display.

- Turn button D forwards to select a hydraulic flow for circuit B of between 10% and 100%.

- Hold button D at the desired flow and confirm with the  button.

- The screen  appears on the lower screen display.

- Turn button D backwards to select a hydraulic flow for circuit A between -10% and -100%.

- Hold button D at the desired flow and confirm with the  button.

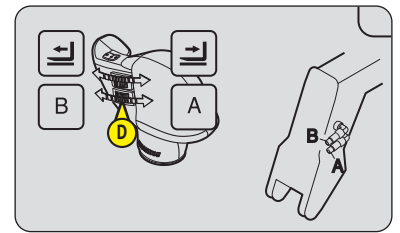
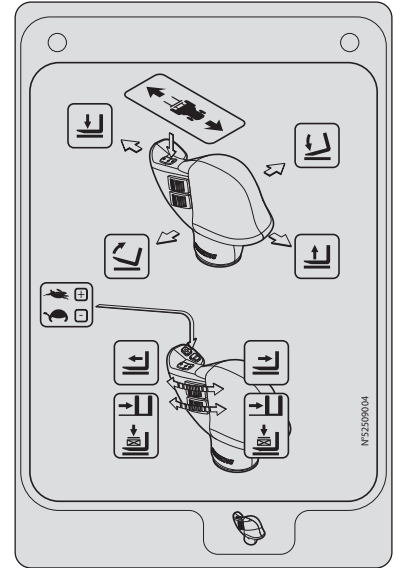

- The hour meter screen  appears on the lower display screen, confirming that adjustment is completed.



**19 - SPEED SELECTOR**

Speeds can be selected while driving.

Buttons 1 and 2 are used to select a speed.

- HIGH SPEED: For driving on the road. Press button 1, the high speed indicator lamp comes on .
- SLOW SPPED: For handling operations. Press button 2, the slow speed indicator lamp comes on .

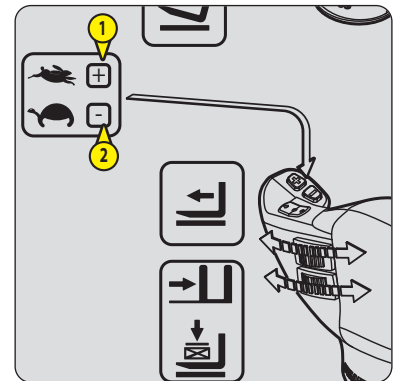

21 - SERVICE BRAKE PEDAL AND TRANSMISSION CUT-OFF

The pedal acts on the front wheels by means of a hydraulic brake system to slow down and stop the lift truck. During free travel it enables the transmission to be cut off progressively thus allowing a gradual approach (delicate handling) with all the engine power.

22 - FORWARD/NEUTRAL/REVERSE GEAR SELECTION

When changing the direction of travel, the lift truck should be travelling at slow speed and not accelerating.

FORWARD: Push the switch forward (position A).

REVERSE: Tilt the switch backwards (position B). A reversing light and audible reversing alarm (OPTION) indicate that the lift truck is travelling in reverse.

NEUTRAL: If indicator lamps   or  are flashing, move the forward/reverse selector back through neutral (position C).

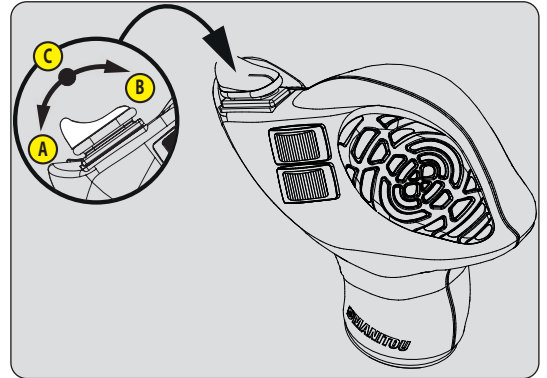

SAFETY FOR MOVING THE LIFT TRUCK

Authorisation to move the lift truck is controlled by an electronic module.



The operator must observe the following sequence of operations to move the truck forwards or backwards:

- 1 - sit down correctly in the driver's seat,
- 2 - release the parking brake,
- 3 - engage forward or reverse.

To stop the forklift truck, the following sequence must be observed:

- 1 - set the forward/reverse selector to neutral,
- 2 - engage the parking brake,
- 3 - get out of the lift truck.

- If the operator leaves the driver's cab with forward or reverse engaged, the screen  will appear and generate

a sound alarm for two seconds. During this time, the operator can sit back down in the seat and continue advancing or reversing. When this time is exceeded, the transmission will switch to neutral and the indicator lamps   or  will flash. The operator must sit back down and pass the forward/reverse selector back through neutral.

SAFETY FOR MOVING THE LIFT TRUCK

The operator must observe the following sequence to move the truck forwards or backwards:

- 1 - sit down correctly in the driver's seat,
- 2 - release the parking brake,
- 3 - engage forward or reverse.

## 23 - STEERING SELECTION

### A - GREEN WHEEL ALIGNMENT INDICATOR LAMPS

#### ⚠ IMPORTANT ⚠

*Before selecting one of the three steering possibilities, align the 4 wheels in relation to the lift truck axis.  
Never change the steering mode whilst driving.*

These green indicator lamps come on to indicate the alignment of the wheels in relation to the lift truck. The A1 indicator lamp for the front wheels and the A2 indicator lamp for the rear wheels.

### B - STEERING SELECTION LEVER

- B1 - Front drive wheels (road traffic).
- B2 - Front and rear drive wheels in the opposite direction (small turning circle).
- B3 - Front and rear drive wheels in the same direction (crabwise movement).

### CHECKING WHEEL ALIGNMENT

#### ⚠ IMPORTANT ⚠

*Before travelling on a public road, it is necessary to check the rear wheel alignment and to travel on front drive wheels.  
Checking the rear wheel alignment must be performed regularly using the green indicator lamps when the forklift truck is in motion.*

*In case of technical faults, consult your dealer.*

- Place the steering selection lever B in position B2 (short turning circle).
- Turn the steering wheel and bring the rear wheels into alignment until the A2 indicator lamp comes on.
- Place the steering selection lever B in position B1 (road traffic).
- Turn the steering wheel and align the front wheels until indicator lamp A1 lights up.

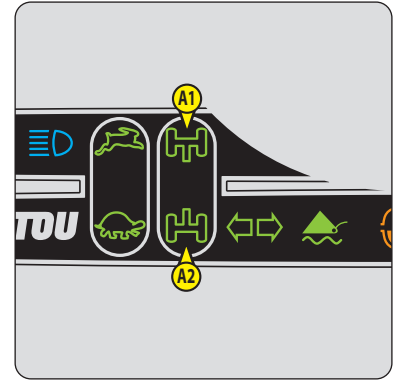

## 24 - HEATER CONTROL

### A - FAN CONTROL

This 3-speed control allows the air to be ventilated through the air vents.

### B - TEMPERATURE CONTROL

Adjusts the temperature inside the cab.

- B1 - The fan pumps in the air at ambient temperature.
- B2 - The fan pumps in warm air.

The intermediate positions allow the temperature to be adjusted.



## 25 - AIR CONDITIONING CONTROLS (AIR CONDITIONING OPTION)

### ⚠ IMPORTANT ⚠

*The air conditioning only works if the lift truck has been started.*

*When using your air conditioning, it is essential to work with the cab closed.*

*In winter: So as to ensure that the air conditioning unit is correctly operated and completely efficient, start up the compressor once a week, even for a short period of time, in order to lubricate the internal seals.*

*In cold weather: Warm the engine before switching on the compressor, in order to allow the coolant that has collected in the liquid state at the lowest point of the compressor's circuit to turn into gas under the effect of the heat given off by the engine, as the compressor is liable to be damaged by coolant in the liquid state.*

*If your air conditioning does not seem to be working correctly, have it examined by your dealer.*

*Never try to repair any faults yourself.*



### A - FAN CONTROL

This 3-speed control allows the air to be ventilated through the air vents.

### B - TEMPERATURE CONTROL

Adjusts the temperature inside the cab.

- B1 - The fan pumps in cold air.
- B2 - The fan pumps in warm air.

The intermediate positions allow the temperature to be adjusted.

### C - AIR CONDITIONING CONTROL

This control with a pilot light allows the air conditioning unit to be switched on.

#### HEATING MODE

The controls must be adjusted in the following way:

- C - Control with pilot light off.
- B - At the desired temperature.
- A - At the desired speed: 1, 2 or 3.

#### AIR CONDITIONING MODE

The controls must be adjusted in the following way:

- C - Control with pilot light on.
- B - At the desired temperature.
- A - At the desired speed: 1, 2 or 3.

#### DEMISTING MODE

The controls must be adjusted in the following way:

- C - Control with pilot light on.
- B - At the desired temperature.
- A - At speed 3.

For optimum effectiveness, close the heating ventilators.

## 26 - HEATING VENTS

These swivelling heating vents, which can be shut off, allow you to direct and adjust the flow inside the cab.

## 27 - DEMIST VENTS

These vents allow the windscreen and side windows to be demisted. For optimum efficiency, close the heating vents.

## 28 - LEVEL INDICATOR

Enables the operator to check that the lift truck is in the horizontal position.



## 29 - DOOR LOCK

Two keys are provided with the lift truck to enable the cabin to be locked.

## 30 - DOOR WINDOW OPENING HANDLE

## 31 - DOOR WINDOW RELEASE BUTTON

## 32 - HANDLE FOR REAR WINDOW OPENING

EMERGENCY EXIT

Use the rear window as an emergency exit, if it is impossible to leave the cab by the door.

## 33 - DOCUMENT STORAGE NET

Make sure that the operator's manual is in the right place, i.e. in the document holder net.

NOTE: An OPTIONAL waterproof document-holder is available.

## 34 - STEERING WHEEL ADJUSTMENT LEVER (OPTION)

This handle enables the angle and height of the steering wheel to be adjusted.

- Pull the handle 1 backwards.
- Adjust the steering wheel to the desired position.
- Push the knob back to lock the steering wheel in position.



### 35 - FRONT HEADLIGHTS

- A - Left front indicator light.
- B - Left front dipped beam headlight.
- C - Left front main beam.
- D - Left front side light.
- E - Right front indicator light.
- F - Right front dipped beam headlight.
- G - Right front main beam headlight.
- H - Right front side light.



### 36 - REAR LIGHTS

- A - Left rear indicator light.
- B - Left rear brake light.
- C - Left rear light.
- D - Rear fog light.
- E - Reversing light.
- F - Right rear light.
- G - Right rear brake light.
- H - Right rear indicator light.

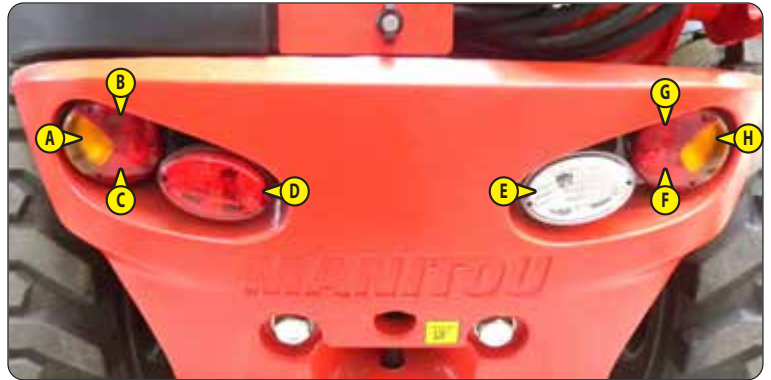

### 37 - ROTATING BEACON LIGHT

The magnetic rotating beacon light must be clearly visible on the roof of the cab and plugged into socket 1.



### 38 - ROOF LIGHT (OPTION)

### 39 - ROOF-SIDE WINDSCREEN WIPER SWITCH (OPTION)

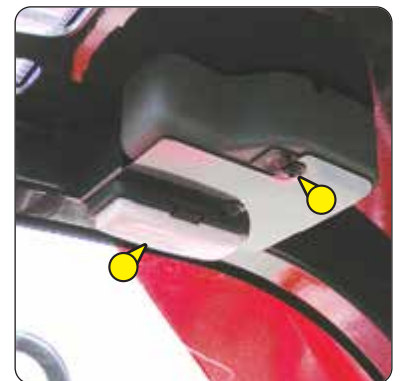

### 40 - SUN VISOR (OPTION)



## 41 - BOOM SAFETY WEDGE

### **⚠ IMPORTANT ⚠**

*Only use the wedge supplied with the lift truck.*

The lift truck is equipped with a boom safety wedge which must be installed on the rod of the lifting cylinder when working beneath the boom (⇐ 1 - OPERATING AND SAFETY INSTRUCTIONS).



## 42 - FUEL TANK

As far as possible, keep the fuel tank well filled in order to minimise condensation due to the atmospheric conditions.

### **⚠ IMPORTANT ⚠**

*Never smoke or approach with a flame during filling operations or when the tank is open.*

*Never refill while the engine is running.*

- If necessary, add diesel (⇐ 3 - MAINTENANCE: LUBRICANTS AND FUEL).
- Remove cap 1.
- Fill the fuel tank with clean diesel filtered through the filler port.
- Refit the cap.
- Visually check that there is no leakage in the tank and pipes.

NOTE: A locking tank cap is available as an OPTION.



## TOWING DEVICE

### ⚠ IMPORTANT ⚠

*Do not tow a trailer or an attachment that is not in perfect working condition.*

*Using a trailer in poor condition may affect the lift truck's steering and braking, and hence the safety of the assembly.*

*If a third party helps in coupling or uncoupling the trailer, this person must be permanently visible to the driver and wait until the lift truck has stopped, the handbrake is on and the I.C. engine is switched off before performing the operation.*

Located at the rear of the lift truck, this device is used to couple a trailer. Capacity is limited for each lift truck by the authorised gross vehicle weight (AGVW), tractive effort and maximum vertical force on the coupling point. This information is given on the manufacturer's plate fixed to each lift truck (⇐ IDENTIFICATION OF THE LIFT TRUCK).

- To use a trailer, see current regulations in your country (maximum running speed, braking, maximum weight of trailer, etc.).
- Verify the trailer's condition before using it (tyre condition and pressures, electrical connection, hydraulic hose, brake system...).

NOTE Our tractor type-approved lift trucks are not compatible for use with trailers fitted with the ISO7638 socket.

### 1 - TOWING PIN

#### ⚠ IMPORTANT ⚠

*Be careful not to get your fingers caught or crushed during this operation.*

*Do not forget to put the cotter pin back in place.*

*When uncoupling, make sure that the trailer is supported independently.*

#### COUPLING AND UNCOUPLING THE TRAILER

- To couple the trailer, position the lift truck as close as possible to the trailer ring.
- Apply the handbrake on and switch off the engine.
- Open the rear cover 1.
- Remove the pin 2, lift the towing pin 3 and place or remove the trailer ring.



## DESCRIPTION AND USE OF THE OPTIONS

1 - PREHEAT ROD.....	2-50
2 - MODCOD ANTI-THEFT SYSTEM.....	2-50
3 - WINDSCREEN GRILL.....	2-51
4 - MODCLE ANTI-START SYSTEM.....	2-51
5 - ANGULAR SECTOR ON BOOM.....	2-51
6 - EXTERIOR DRAIN-BACK.....	2-51
7 - "A-B-C" MARKING ON BOOM (ONLY AUSTRALIA).....	2-51
8 - BOOM ELECTRICAL PREDISPOSITION.....	2-52
9 - ATTACHMENT HYDRAULIC LOCKING.....	2-52
10 - BOOM HEAD ELECTROVALVE.....	2-53
11 - BOOM HEAD ELECTROVALVE + HYDRAULIC ATTACHMENT LOCKING.....	2-53
12 - ATTACHMENT HYDRAULIC CONTROL FORCED OPERATION.....	2-54
13 - ENGINE SPEED REGULATOR.....	2-54
14 - SPEED LIMITER.....	2-54
15 - LIFTING RING ON SINGLE CARRIAGE.....	2-55
16 - REFLECTIVE BANDS.....	2-55
17 - INSIDE REAR-VIEW MIRROR.....	2-55
18 - TELEPHONE HOLDER.....	2-55
19 - FRONT AND REAR CAMERAS.....	2-56

### 1 - PREHEAT ROD

Enables the engine block to be kept warm during prolonged periods of stoppage and thus improves engine starting.

#### SUPPLY CHARACTERISTICS OF PREHEATING SYSTEM:

- Rated power supply voltage range: 220-240 V; 50-60 Hz.
- Current consumed: 4.5 A.
- Class 1 equipment.
- Equipment can only be connected to TT or TN supply diagrams.
- Installation category 2.

#### ENVIRONMENTAL CONDITIONS FOR USE:

- Maximum ambient temperature for using preheat: +25°C.
- Pollution level 2.

#### CONDITIONS FOR CONNECTION AND USE OF PREHEATING:

- The preheat system should not be used for an external ambient temperature higher than + 25°C.
- It is essential that the power supply to the preheating system:
  - Is effected with a cable that conforms to the installation standards in force and contains a protective earth conductor.
  - Contains an appropriate sectioning system.
  - Incorporates an appropriate safety system against short circuits (fuses or circuit breaker) and a differential circuit breaker with 30 mA sensitivity.
- Only connect to and disconnect from the power supply while the unit is switched off and the engine is stopped.



### 2 - MODCOD ANTI-THEFT SYSTEM

#### OPERATION

- Switch on lift truck ignition, red LED 1 will flash.
- Enter your user code followed by "V" to validate, green LED 2 will light.
- Start the lift truck within the next 60 seconds; otherwise the anti-theft system will be reactivated and red LED 1 will flash.

NOTE: If you make a mistake when entering the code, press key "A" to cancel and re-enter the code in full. If you wait more than 5 seconds between key presses, code entry is abandoned, the anti-theft system is reactivated and the red LED will flash.



### 3 - WINDSCREEN GRILL

#### DESCRIPTION

The windscreen grill provides additional protection for the operator from any external elements spattered on the windscreen.



### 4 - MODCLE ANTI-START SYSTEM

#### OPERATION

- Switch on lift truck ignition, red LED 1 will flash.
- Apply key 2 to its base 3, and withdraw it as soon as the system emits a continuous sound signal, and LED 1 turns green.
- Start the lift truck within the next 20 seconds; otherwise the anti-theft system will be reactivated and red LED 1 will flash.

NOTE: You can restart the lift truck within 20 seconds of stopping it; after this time, the anti-start system reacts and red LED 1 flashes.



### 5 - ANGULAR SECTOR ON BOOM

The angular sector displays the boom angle, and thus improves the reading of the load charts.



### 6 - EXTERIOR DRAIN-BACK

Enables connection of an attachment for which drain-back is required.



### 7 - "A-B-C" MARKING ON BOOM (ONLY AUSTRALIA)

The marking indicates the outreach of the boom and therefore improves reading of the load charts.

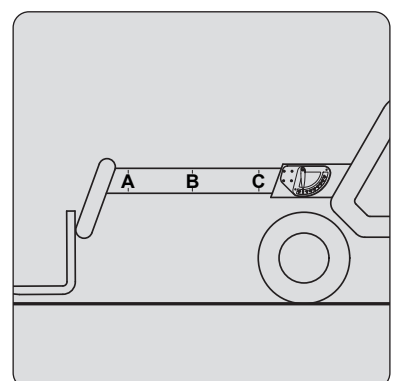

## 8 - BOOM ELECTRICAL PREDISPOSITION

Enables an electrical function to be used at the head of the boom.

### OPERATION

- Set switch 1 to position A to activate the predisposition, the indicator lamp comes on to show that it is activated.



## 9 - ATTACHMENT HYDRAULIC LOCKING

MT 420 H 57K ST5 S1

Enables the attachment to be locked onto the carriage and a hydraulic attachment to be used by the same hydraulic circuit.

### ATTACHMENT LOCKING CONTROL

- Put tap 1 in position A and press switch 2 at position B (indicator lamp on).
- Push switch 3 forward to lock the attachment and backward to release it.

**⚠ IMPORTANT ⚠**

*After locking the attachment, return switch 2 to position A (indicator lamp off) to prevent accidental unlocking of the attachment.*

### HYDRAULIC ATTACHMENT CONTROL

- Put the tap in position B and press switch 2 at position B (indicator lamp on).
- Push switch 3 forward or backward.

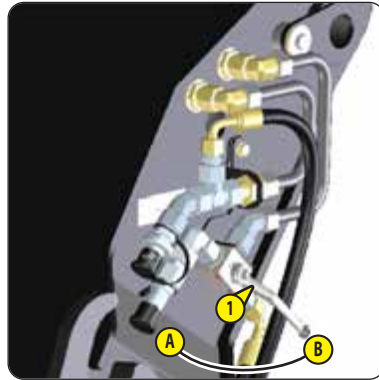
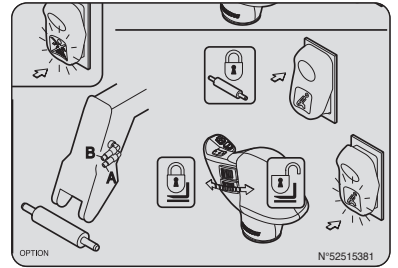

## 10 - BOOM HEAD ELECTROVALVE

Enables use of two hydraulic functions on the attachment circuit.

### **⚠ IMPORTANT ⚠**

*To facilitate connection of the quick couplers, decompress the hydraulic circuit by pressing button 1 on the electrovalve.*

#### ATTACHMENT LINE A1/B1 CONTROL

- Put switch 1 to position A (indicator lamp off).
- Push switch 2 forward or backward.

#### ATTACHMENT LINE A2/B2 CONTROL

- Put switch 1 to position B (indicator light on) and hold down button 3.
- Push switch 2 forward or backward.

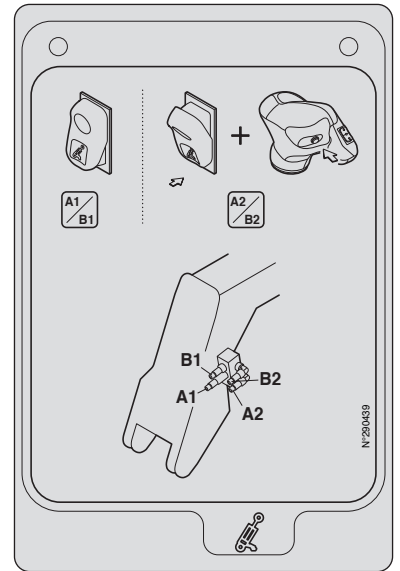

## 11 - BOOM HEAD ELECTROVALVE + HYDRAULIC ATTACHMENT LOCKING

Enables the use of a hydraulic function and hydraulic locking of the attachment on the attachment circuit.

### **⚠ IMPORTANT ⚠**

*To facilitate connection of the quick couplers, decompress the hydraulic circuit by pressing button 1 on the electrovalve.*

#### ATTACHMENT LINE A1/B1 CONTROL

- Put switch 1 to position A (indicator lamp off).
- Push switch 2 forward or backward.

#### ATTACHMENT A2/B2 LOCKING CONTROL

- Put switch 1 to position B (indicator light on) and hold down button 3.
- Push switch 2 forward to lock the attachment and backward to release it.

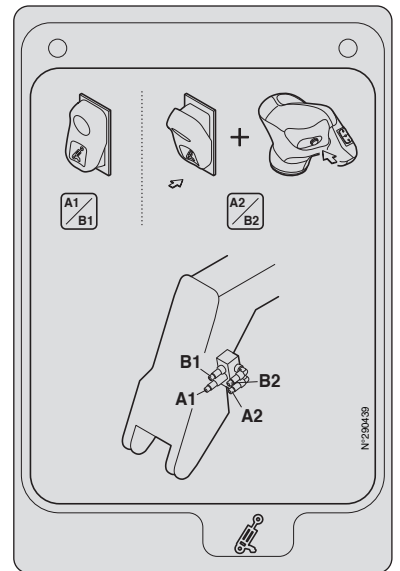

## 12 - ATTACHMENT HYDRAULIC CONTROL FORCED OPERATION

### ⚠ IMPORTANT ⚠

*This OPTION must only be used with an attachment requiring continuous hydraulic movement, such as a brush, feeder bucket, mixer, spray etc. It is strictly forbidden for use in handling operations and all other applications (winch, crane jib, crane jib with winch, hook, etc.).*

### CONTINUOUS HYDRAULIC MOVEMENT OF THE ATTACHMENT

- Simultaneously hold button 1 in the forward or backward position (according to the type of attachment) and switch 2 in position B (indicator light on). An audible alarm will sound when activated. Release button 1 and switch 2.
- To stop the movement, press again on the bottom of switch 1, or operate button 2.

NOTE: If the operator leaves the driver's cab, the continuous hydraulic movement will automatically stop and must be restarted.

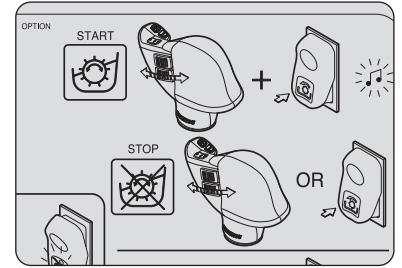

## 13 - ENGINE SPEED REGULATOR

### ⚠ IMPORTANT ⚠

*This option cannot under any circumstances be used while driving on the road.  
Caution when driving, sudden acceleration or braking when you use button 2.*

The regulator controls the engine speed, increases the hydraulic flow and therefore increases the speed of all the movements.

- Adjust the engine speed with lever 1.

Used for an attachment requiring continuous hydraulic movement (brush, feeder bucket, mixer, spray).



## 14 - SPEED LIMITER

### ⚠ IMPORTANT ⚠

*This option cannot under any circumstances be used while driving on the road.*

Only accessible in TORTOISE MODE, the speed limiter limits the speed from 0,4 km/h to 12 km/h by turning the button 1.

Use for an attachment requiring a constant speed of travel (brush, feeder bucket, spray).

- After having switched off the ignition with the ignition key turn button 1 to zero to reinitialise this option then reset to the desired value.



## 15 - LIFTING RING ON SINGLE CARRIAGE

MT 420 H 57K ST5 S1

### CONDITIONS OF USE

#### ⚠ IMPORTANT ⚠

Follow the instructions given in your lift truck's instruction manual (⚡ 1 - OPERATING AND SAFETY INSTRUCTIONS FOR HANDLING LOADS), and in addition those given below.

- The lifting ring must be used WITHOUT FORKS AND ATTACHMENTS, but the angle of inclination of the carriage must be same as when the forks are used in the horizontal position.
- Check the maximum permitted angle, which is 45°.
- Do not change the angle of the carriage while using the lifting ring.
- The lifting hook, the chains and slings shall have a minimum capacity of 3000 kg with a safety coefficient of 4 in relation to breakage.

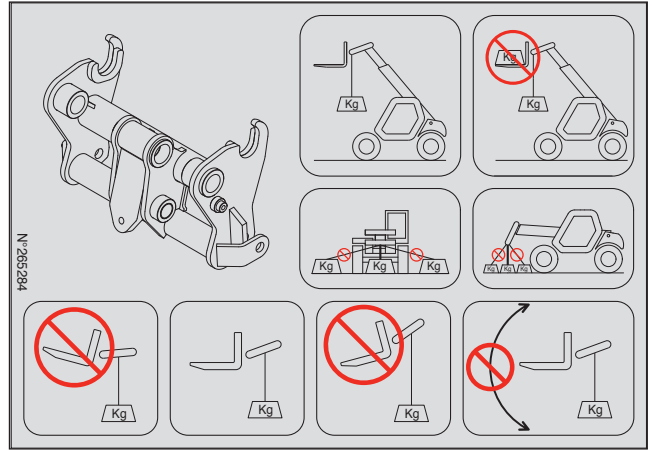

### LOAD CHARTS AND FUNCTION SHEETS

#### ⚠ IMPORTANT ⚠

The load charts are defined for use without forks and without attachments.

## 16 - REFLECTIVE BANDS

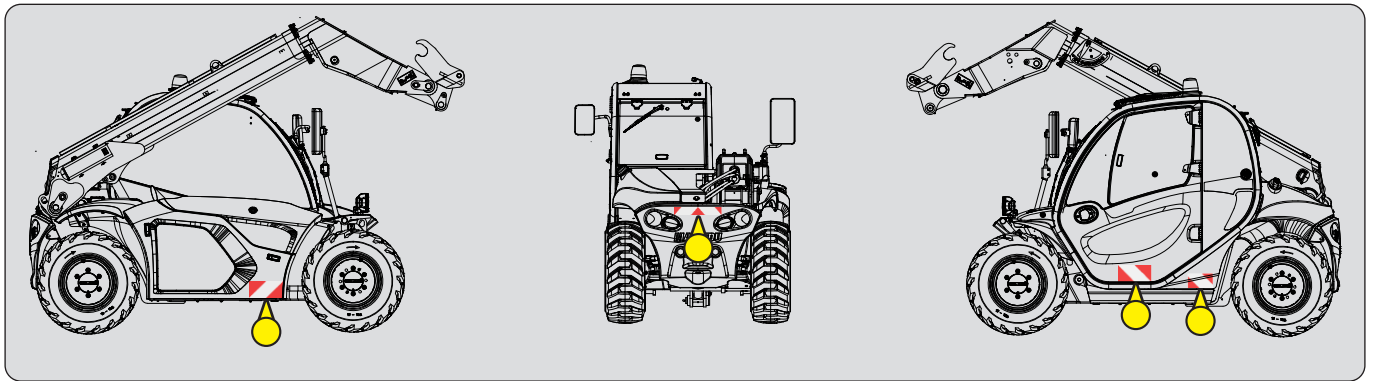

## 17 - INSIDE REAR-VIEW MIRROR

## 18 - TELEPHONE HOLDER



## 19 - FRONT AND REAR CAMERAS

The front and rear cameras can be configured in manual or automatic mode:

- Turn on monitor A by pressing "POWER".
- In the menu screen, go to the options tab "OPT".
- Select "CAM 1/CAM 2" then choose the required operating mode.

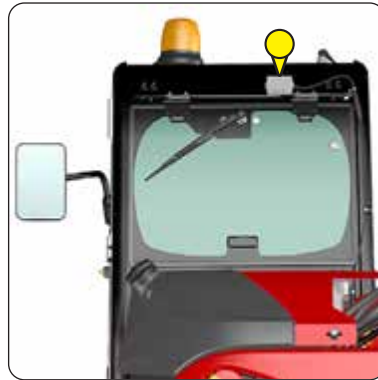

# ***3 - MAINTENANCE***

### 3 - MAINTENANCE

<b>ORIGINAL MANITOU SPARE PARTS AND EQUIPMENT</b>	<b>3-3</b>
<b>FORKLIFT TRUCK MAINTENANCE</b>	<b>3-4</b>
<b>DAILY AND WEEKLY MAINTENANCE</b>	<b>3-4</b>
<b>MANDATORY FIRST 500 HOURS OR 6 MONTHS SERVICE</b>	<b>3-5</b>
<b>PERIODIC SERVICE</b>	<b>3-6</b>
<b>OCCASIONAL MAINTENANCE AND OPERATION</b>	<b>3-8</b>
<b>FILTER CARTRIDGES AND BELTS</b>	<b>3-9</b>
<b>LUBRICANTS AND FUEL</b>	<b>3-10</b>
<b>➞ 10H - DAILY SERVICE OR EVERY 10 HOURS OF SERVICE</b>	<b>3-12</b>
<b>➞ 50H - WEEKLY SERVICE OR EVERY 50 HOURS OF SERVICE</b>	<b>3-14</b>
<b>➞ ① 500H - PERIODIC SERVICE - EVERY 500 HOURS OF SERVICE OR 1 YEAR</b>	<b>3-20</b>
<b>➞ ② 1000H - PERIODIC SERVICE - EVERY 1000 HOURS OF SERVICE OR 2 YEARS</b>	<b>3-26</b>
<b>➞ ③ 2000H - PERIODIC SERVICE - EVERY 2000 HOURS OF SERVICE OR 4 YEARS</b>	<b>3-32</b>
<b>➞ ④ 3000H - PERIODIC SERVICE - EVERY 3000 HOURS OF SERVICE OR 6 YEARS</b>	<b>3-35</b>
<b>➞ OCCASIONAL MAINTENANCE</b>	<b>3-36</b>
<b>➞ OCCASIONAL OPERATION</b>	<b>3-40</b>

## ORIGINAL MANITOU SPARE PARTS AND EQUIPMENT

OUR LIFT TRUCKS MUST BE SERVICED USING ORIGINAL MANITOU PARTS.

### **BY ALLOWING THE USE OF NON ORIGINAL MANITOU PARTS, YOU RISK:**

---

**⚠ IMPORTANT ⚠**

**THE USE OF COUNTERFEIT PARTS OR COMPONENTS NOT APPROVED BY THE MANUFACTURER, MEANS YOU LOSE THE BENEFIT OF THE CONTRACTUAL GUARANTEE.**

- Legally - to be held responsible in the event of an accident.
- Technically - to cause operating malfunctions or shorten the life of the lift truck.

### **BY USING ORIGINAL MANITOU PARTS FOR MAINTENANCE OPERATIONS, YOU BENEFIT FROM OUR KNOW-HOW**

---

Through its network, MANITOU provides the user with,

- Know-how and competence.
- The guarantee of high-quality work.
- Original replacement parts.
- Help with preventive maintenance.
- Efficient help with diagnosis.
- Improvements due to experience feedback.
- Operator training.
- Only the MANITOU network has detailed knowledge of the design of the lift truck and therefore the best technical ability to provide maintenance.

**⚠ IMPORTANT ⚠**

**ORIGINAL REPLACEMENT PARTS ARE DISTRIBUTED EXCLUSIVELY BY MANITOU AND ITS DEALER NETWORK.**

*The dealer network list is available on the MANITOU web site: [www.manitou.com](http://www.manitou.com)*

## FORKLIFT TRUCK MAINTENANCE

### DAILY AND WEEKLY MAINTENANCE



**THE OPERATOR IS AUTHORISED TO CARRY OUT THIS MAINTENANCE.**

These maintenance operations enable the operator to maintain the lift truck in a clean and safe condition.

### MANDATORY FIRST 500 HOURS OR 6 MONTHS SERVICE



**THIS SERVICE MUST BE CARRIED OUT AFTER THE FIRST 500 HOURS OF SERVICE OR WITHIN THE 6 MONTHS FOLLOWING PUTTING THE MACHINE INTO SERVICE (WHICHEVER OCCURS FIRST).**

### PERIODIC SERVICE



**THE PERIODIC MAINTENANCE MUST BE CARRIED OUT BY AN APPROVED PROFESSIONAL FROM THE MANITOU NETWORK.**

### MAINTENANCE SCHEDULE

This schedule enables the operator to keep up with the periodic service of the lift truck by notifying the total number of hours of operation and the date of the service performed by the professional approved by the MANITOU network.

### OCCASIONAL MAINTENANCE AND OPERATION

These maintenance tasks and operations are to be performed as required for the safety and upkeep of the lift truck.

## DAILY AND WEEKLY MAINTENANCE

### ↻ 10H - DAILY SERVICE OR EVERY 10 HOURS OF SERVICE

- CHECK	Lift truck environment .....	3-12
- CHECK	Engine oil level .....	3-12
- CHECK	Cooling liquid level .....	3-12
- CHECK	Longitudinal stability limiter and warning device .....	3-13

### ↻ 50H - WEEKLY SERVICE OR EVERY 50 HOURS OF SERVICE

- CHECK	Alternator/crankshaft belt tension .....	3-14
- CHECK	Compressor belt tension (Air conditioning option) .....	3-14
- CHECK	Transfer box oil level .....	3-14
- CHECK	Tyre pressures .....	3-14
- CHECK	Wheel nut tightening .....	3-14
- CHECK	Front axle differential seal .....	3-15
- CHECK	Rear axle differential seal .....	3-15
- CHECK	Front wheel reducer seals .....	3-15
- CHECK	Rear wheel reducer seals .....	3-15
- CHECK	Brake fluid level .....	3-15
- CHECK	Boom pad slide pathways .....	3-15
- CHECK	Hydraulic oil level .....	3-16
- CHECK	Windscreen washer liquid level .....	3-16
- CLEAN	Fuel pre-filter .....	3-16
- CLEAN	Radiator cores .....	3-17
- CLEAN	Dry air filter cartridge .....	3-17
- CLEAN	Condenser wiring harness (Air conditioning OPTION) .....	3-17
- LUBRICATE	General lubrication .....	3-18
- REPLACE	Engine oil * .....	3-19
- REPLACE	Engine oil filter * .....	3-19

**\* Only for the first 50 hours of service and then every 500 hours of service or 1 year.**

## MANDATORY FIRST 500 HOURS OR 6 MONTHS SERVICE

### FIRST 500 HOURS BEFORE THE FIRST 6 MONTHS

- If the lift truck has reached the first 500 hours of service before the first 6 months have expired, perform both the mandatory service and periodic 500 H service (🔍 ➡️ ① 500H - PERIODIC SERVICE - EVERY 500 HOURS OF SERVICE OR 1 YEAR).

### FIRST 6 MONTHS BEFORE THE FIRST 500 HOURS

- If the lift truck has not completed 500 hours of service in the first 6 months, just carry out the mandatory service.

## ➡️ MANDATORY SERVICE

- CHECK	Alternator/crankshaft belt tension .....	3-14
- CHECK	Compressor belt tension (Air conditioning option) .....	3-14
- CHECK	Transfer box oil level .....	3-14
- CHECK	Tyre pressures .....	3-14
- CHECK	Wheel nut tightening .....	3-14
- CHECK	Front axle differential seal .....	3-15
- CHECK	Rear axle differential seal .....	3-15
- CHECK	Front wheel reducer seals .....	3-15
- CHECK	Rear wheel reducer seals .....	3-15
- CHECK	Brake fluid level .....	3-15
- CHECK	Boom pad slide pathways .....	3-15
- CHECK	Hydraulic oil level .....	3-16
- CHECK	Windscreen washer liquid level .....	3-16
- CLEAN	Fuel pre-filter .....	3-16
- CLEAN	Radiator cores .....	3-17
- CLEAN	Dry air filter cartridge .....	3-17
- CLEAN	Condenser wiring harness (Air conditioning OPTION) .....	3-17
- LUBRICATE	General lubrication .....	3-18
- LUBRICATE	Engine cover opening .....	3-20
- CHECK	Hoses and differential pressure hoses for the exhaust particle filter "DPF" ** .....	3-24
- CHECK	Exhaust gas recirculation piping "EGR" ** .....	3-24
- CHECK	Intake hose ** .....	3-24
- CHECK	**Exhaust manifold .....	3-24
- CHECK	Fork wear * .....	3-24
- CHECK	Safety belt .....	3-26
- CHECK	Silentblocks ** .....	3-30
- CHECK	Valve lash ** .....	3-30
- CHECK	Injectors ** .....	3-30
- CHECK	Exhaust gas recirculation cooler "EGR" ** .....	3-30
- CHECK	Casing gas recycling valve ** .....	3-30
- CHECK	Brake system pressure * .....	3-30
- CHECK	Boom pad wear * .....	3-30
- CHECK	Condition of wiring harnesses and cables * .....	3-30
- CHECK	Lights and signals * .....	3-30
- CHECK	Warning indicators * .....	3-30
- CHECK	Condition of the rear-view mirrors * .....	3-30
- CHECK	Cabin structure * .....	3-30
- CHECK	Frame structure * .....	3-30
- CHECK	Attachment carriage * .....	3-30
- CHECK	Condition of attachments * .....	3-30

**\*\* Engine service, consult your dealer.**

**\* Consult your dealer.**

## PERIODIC SERVICE

### MAINTENANCE SCHEDULE

	↻ OR ↻					
WHEN DUE ➡	FIRST 6 MONTHS	FIRST 500 HOURS	500 H or 1 YEAR	1000 H or 2 YEARS	1500 H or 3 YEARS	2000 H or 4 YEARS
PERIODIC SERVICE ➡	MANDATORY SERVICE	MANDATORY SERVICE + ①	①	①+②	①	①+②+③
MACHINE COUNTER ➡						
DATE OF SERVICING ➡						

WHEN DUE ➡	2500 H or 5 YEARS	3000 H or 6 YEARS	3500 H or 7 YEARS	4000 H or 8 YEARS	4500 H or 9 YEARS	5000 H or 10 YEARS	5500 H or 11 YEARS
PERIODIC SERVICE ➡	①	①+②+④	①	①+②+③	①	①+②	①
MACHINE COUNTER ➡							
DATE OF SERVICING ➡							

WHEN DUE ➡	6000 H or 12 YEARS	6500 H or 13 YEARS	7000 H or 14 YEARS	7500 H or 15 YEARS	8000 H or 16 YEARS	8500 H or 17 YEARS	9000 H or 18 YEARS
PERIODIC SERVICE ➡	①+②+③+④	①	①+②	①	①+②+③	①	①+②+④
MACHINE COUNTER ➡							
DATE OF SERVICING ➡							

### ➡ ① 500H - PERIODIC SERVICE - EVERY 500 HOURS OF SERVICE OR 1 YEAR

- CHECK	Condition of cables .....	3-20
- CHECK	Hydraulic oil .....	3-20
- LUBRICATE	Engine cover opening.....	3-20
- REPLACE	Engine oil.....	3-21
- REPLACE	Engine oil filter.....	3-21
- REPLACE	Fuel filter .....	3-22
- REPLACE	Fuel pre-filter .....	3-22
- REPLACE	Hydraulic return oil filter cartridge.....	3-23
- REPLACE	Cab fan filter.....	3-23
- CHARGE	12 V battery.....	3-24
- CHECK	Hoses and differential pressure hoses for the exhaust particle filter "DPF" **.....	3-24
- CHECK	Exhaust gas recirculation piping "EGR" **.....	3-24
- CHECK	Intake hose **.....	3-24
- CHECK	**Exhaust manifold.....	3-24
- CHECK	Fork wear * .....	3-24

**\*\* Engine service, consult your dealer.**

**\* Consult your dealer.**

## ➔ ② 1000H - PERIODIC SERVICE - EVERY 1000 HOURS OF SERVICE OR 2 YEARS

### ALSO PERFORM THE 500 HOUR PERIODIC MAINTENANCE OPERATIONS.

- CHECK	Safety belt .....	3-26
- CLEAN	Fuel tank .....	3-26
- REPLACE	Alternator belt .....	3-27
- REPLACE	Engine crankcase ventilation filter .....	3-27
- REPLACE	Dry air filter cartridge .....	3-28
- REPLACE	Coolant .....	3-28
- REPLACE	Transfer box oil .....	3-29
- REPLACE	Front axle differential oil .....	3-29
- REPLACE	Rear axle differential oil .....	3-29
- REPLACE	Front wheel reducer oil .....	3-29
- REPLACE	Rear wheel reducer oil .....	3-29
- CHECK	Silentblocks ** .....	3-30
- CHECK	Valve lash ** .....	3-30
- CHECK	Injectors ** .....	3-30
- CHECK	Exhaust gas recirculation cooler "EGR" ** .....	3-30
- CHECK	Casing gas recycling valve ** .....	3-30
- CHECK	Brake system pressure * .....	3-30
- CHECK	Boom pad wear * .....	3-30
- CHECK	Condition of wiring harnesses and cables * .....	3-30
- CHECK	Lights and signals * .....	3-30
- CHECK	Warning indicators * .....	3-30
- CHECK	Condition of the rear-view mirrors * .....	3-30
- CHECK	Cabin structure * .....	3-30
- CHECK	Frame structure * .....	3-30
- CHECK	Attachment carriage * .....	3-30
- CHECK	Condition of attachments * .....	3-30
- REPLACE	Brake fluid * .....	3-30
- BLEED	Brake circuit * .....	3-30
- ADJUST	Brake * .....	3-30

**\*\* Engine service, consult your dealer.**

**\* Consult your dealer.**

## ➔ ③ 2000H - PERIODIC SERVICE - EVERY 2000 HOURS OF SERVICE OR 4 YEARS

### ALSO PERFORM THE 500 HOUR AND 1000 HOUR PERIODIC MAINTENANCE OPERATIONS.

- CHECK	Wheel nut tightening torques .....	3-32
- REPLACE	Dry air filter safety cartridge .....	3-32
- REPLACE	Hydraulic oil .....	3-33
- REPLACE	Brake accumulator unit filter .....	3-33
- CHECK	Radiator * .....	3-34
- CHECK	Transmission pressures * .....	3-34
- CHECK	Steering * .....	3-34
- CHECK	Steering swivel joints * .....	3-34
- CHECK	Brake pad and brake disk wear * .....	3-34
- CHECK	Condition of boom assembly * .....	3-34
- CHECK	Bearings and bushings * .....	3-34
- CHECK	Condition of hoses and flexible pipes * .....	3-34
- CHECK	Condition of cylinders (leakage, rods) * .....	3-34
- CHECK	Hydraulic circuit pressures * .....	3-34
- CLEAN	Air conditioning (OPTION) * .....	3-34
- REPLACE	Compressor belt (Air Conditioning OPTION) * .....	3-34

**\* Consult your dealer.**

## ➔ ④ 3000H - PERIODIC SERVICE - EVERY 3000 HOURS OF SERVICE OR 6 YEARS

### ALSO PERFORM THE 500 HOUR AND 1000 HOUR PERIODIC MAINTENANCE OPERATIONS.

- CHECK	Turbocharger ** .....	3-35
- CHECK	Exhaust gas recirculation system "EGR" ** .....	3-35
- CLEAN	Exhaust particle filter "DPF" ** .....	3-35

**\*\* Engine service, consult your dealer.**

## OCCASIONAL MAINTENANCE AND OPERATION

### OCCASIONAL MAINTENANCE

---

- CLEAN	"Stationary lift truck" exhaust purification.....	3-36
- REPLACE	Wheels .....	3-37
- ADJUST	Front headlights .....	3-37
- RESET	Longitudinal stability limiter and warning device.....	3-38
- CHECK	Disabling "AGGRAVATING" hydraulic movement cut-off .....	3-39

### OCCASIONAL OPERATION

---

- TOW OR WINCH	Lift truck.....	3-40
- SLING	Lift truck.....	3-41
- TRANSPORT	Lift truck.....	3-42

## FILTER CARTRIDGES AND BELTS

### ➔ ① 500H - PERIODIC SERVICE - EVERY 500 HOURS OF SERVICE OR 1 YEAR



ENGINE OIL FILTER

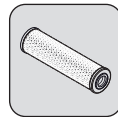

HYDRAULIC RETURN OIL FILTER CARTRIDGE



FUEL PRE-FILTER

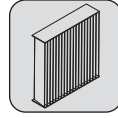

INTERIOR CAB VENTILATION FILTER

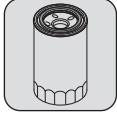

FUEL FILTER

### ➔ ② 1000H - PERIODIC SERVICE - EVERY 1000 HOURS OF SERVICE OR 2 YEARS

**ALSO ADD FILTER ELEMENTS FOR PERIODIC MAINTENANCE AFTER 500 HOURS OF SERVICE.**



ALTERNATOR BELT

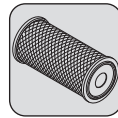

DRY AIR FILTER CARTRIDGE



ENGINE CRANKCASE VENTILATION FILTER

### ➔ ③ 2000H - PERIODIC SERVICE - EVERY 2000 HOURS OF SERVICE OR 4 YEARS

**ALSO ADD FILTER ELEMENTS FOR PERIODIC MAINTENANCE AT 500 HOURS AND 1000 HOURS OF SERVICE.**



SAFETY DRY AIR FILTER CARTRIDGE



VENTILATION CONTROL UNIT FILTER



BREATHER FOR THE HYDRAULIC OIL TANK

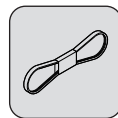

COMPRESSOR BELT  
(AIR CONDITIONING OPTION)



BRAKE ACCUMULATOR UNIT FILTER

### ➔ OCCASIONAL MAINTENANCE

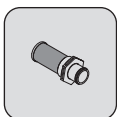

SUCTION STRAINER FOR HYDRAULIC OIL TANK

## LUBRICANTS AND FUEL

### ⚠ IMPORTANT ⚠

- USE THE RECOMMENDED LUBRICANTS AND FUEL:**
- For topping up, oils may not be miscible.
  - For oil changes, MANITOU oils are perfectly appropriate.

### DIAGNOSTIC ANALYSIS OF OILS

If a service or maintenance contract has been set up with the dealer, a diagnostic analysis of engine, transmission and axle oils may be requested depending on the rate of use.

### (\*) REQUIRED FUEL SPECIFICATION

Use a high-quality fuel to obtain optimal performance of the engine.

- EN590 diesel fuel (sulphur content < 10 ppm)
- ASTM D975 diesel fuel (sulphur content < 15 ppm)

### RECOMMENDATION

ENGINE		RECOMMENDATION										
DESCRIPTION	CAPACITY	-40°C	-30	-20	-10	0	+10	+20	+30	+40	+50°C	
ENGINE	8,5 ℓ	0W30										
		0W40										
		5W30										
		5W40										
		10W30										
		<b>MANITOU EVOLOGY OIL 10W40 API CJ4</b>										
15W40												
20W50												
		-40°C	-30	-20	-10	0	+10	+20	+30	+40	+50°C	
COOLING CIRCUIT	7,5 ℓ	<b>COOLANT -35°C</b>										
		-40°C	-30	-20	-10	0	+10	+20	+30	+40	+50°C	
FUEL TANK	60 ℓ	<b>DIESEL FUEL (*)</b>										

BOOM		RECOMMENDATION										
DESCRIPTION		-40°C	-30	-20	-10	0	+10	+20	+30	+40	+50°C	
BOOM PAD SLIDE PATHWAYS		<b>MANITOU BLACK MULTI-PURPOSE LUBRICANT</b>										
		-40°C	-30	-20	-10	0	+10	+20	+30	+40	+50°C	
GREASING OF THE BOOM		<b>MANITOU BLUE MULTI-PURPOSE LUBRICANT</b>										

HYDRAULICS		RECOMMENDATION										
DESCRIPTION	CAPACITY	-40°C	-30	-20	-10	0	+10	+20	+30	+40	+50°C	
HYDRAULIC OIL TANK	55 ℓ	ISO VG 100										
		ISO VG 68										
		<b>MANITOU ISO VG 46 HYDRAULIC OIL</b>										
		ISO VG 37										
		ISO VG 32										

BRAKES		RECOMMENDATION										
DESCRIPTION	CAPACITY											
BRAKE SYSTEM	1 ℓ	<b>MANITOU MINERAL BRAKE FLUID</b>										

CAB		RECOMMENDATION										
DESCRIPTION	CAPACITY											
WINDSCREEN WASHER TANK	4 ℓ	<b>WINDSCREEN WASHER LIQUID</b>										

<b>FRONT AXLE</b>											
DESCRIPTION	CAPACITY	RECOMMENDATION									
FRONT AXLE DIFFERENTIAL	2,9 ℓ	<b>SPECIAL MANITOU OIL FOR IMMERSSED BRAKES</b>									
		-40°C	-30	-20	-10	0	+10	+20	+30	+40	+50°C
TRANSFER GEAR BOX FRONT WHEEL REDUCING GEAR	0,7 ℓ 2 x 0,25 ℓ	<b>MANITOU SAE80W90 MECHANICAL TRANSMISSION OIL</b>									
		-40°C	-30	-20	-10	0	+10	+20	+30	+40	+50°C
FRONT WHEEL REDUCING GEAR PIVOTS		<b>MANITOU BLACK MULTI-PURPOSE LUBRICANT</b>									

<b>REAR AXLE</b>											
DESCRIPTION	CAPACITY	RECOMMENDATION									
REAR AXLE DIFFERENTIAL	2,9 ℓ	<b>SPECIAL MANITOU OIL FOR IMMERSSED BRAKES</b>									
		-40°C	-30	-20	-10	0	+10	+20	+30	+40	+50°C
REAR WHEEL REDUCING GEAR	2 x 0,25 ℓ	<b>MANITOU SAE80W90 MECHANICAL TRANSMISSION OIL</b>									
		-40°C	-30	-20	-10	0	+10	+20	+30	+40	+50°C
REAR AXLE OSCILLATION		<b>MANITOU BLUE MULTI-PURPOSE LUBRICANT</b>									
		-40°C	-30	-20	-10	0	+10	+20	+30	+40	+50°C
REAR WHEEL REDUCING GEAR PIVOTS		<b>MANITOU BLACK MULTI-PURPOSE LUBRICANT</b>									

**CHECK**

**Lift truck environment**

Carry out a general inspection around the lift truck:

- Fluid leaks or stains on the ground.
- Additional objects on the lift truck and in the cabin.
- Mounting and locking of the attachment.
- Mounting and adjustment of rear-view mirrors.
- Condition of the tyres, to detect cuts, blisters, wear, etc.

**⚠ IMPORTANT ⚠**

*Follow the operator instructions (➤ 1 - OPERATING AND SAFETY INSTRUCTIONS: OPERATOR INSTRUCTIONS).*

**CLEANLINESS OF THE FORKLIFT**

- Cleanliness of lights and rear-view mirror.
- Excess dirt or build-up of material (e.g. straw, flour, sawdust, organic waste, etc.).
- On a daily basis, according to the conditions of use and the environment, the operator should ensure that the forklift truck is kept in a clean condition.
- Particular attention should be paid to accumulations of flammable materials (e.g. straw, flour, sawdust, organic waste, etc.) and fuel or lubricant leaks, as these significantly increase the risk of fire outbreaks.
- A regular inspection of the whole lift truck, especially the engine housing and the central part of the frame, is necessary to see how frequently it needs to be cleaned to prevent these potential accumulations of material or leakages.

**CHECK**

**Engine oil level**

Place the lift truck on level ground with the engine stopped, and let the oil settle in the sump.

- Open the engine cover.
- Pull out dipstick 1.
- Clean the dipstick and check the correct level between the two notches.
- If necessary, add oil (➤ LUBRICANTS AND FUEL) through the filler hole 2.
- Visually check that there is no leakage or seepage.

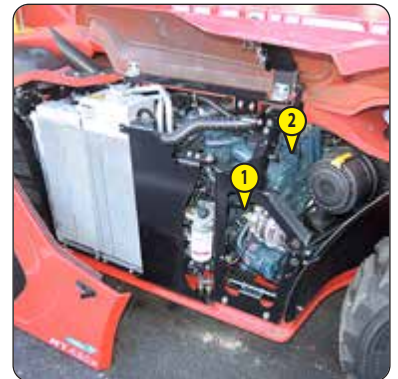

**CHECK**

**Cooling liquid level**

Place the lift truck on level ground with the engine stopped, and allow the engine to cool.

**⚠ IMPORTANT ⚠**

*To avoid any risk of spraying or scalding, wait until the engine has cooled down before removing the cooling system filler plug.*

*In the event of an emergency, it is possible to use water as the coolant, but then proceed to drain the coolant circuit as quickly as possible.*

- Open the engine cover.
- The liquid must be at mid-height in the expansion tank 1.
- If necessary, add coolant (➤ LUBRICANTS AND FUEL) through the filler hole 2.
- Visually check that there is no leakage or seepage.

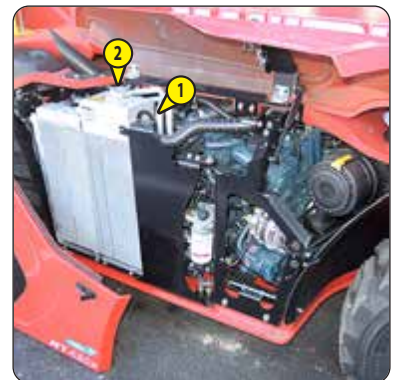

**⚠ IMPORTANT ⚠**











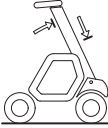

Use the test button  only when instructed, following the guidance for a short press (less than 1 second) or a long press (5 seconds).

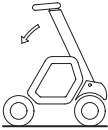
In case of doubt during the test procedure, exit cleanly by a short press on the "BUCKET" MODE  or "SUSPENDED LOAD" buttons .

These tests are essential for checking the correct operation and adjustment of the different components of the device.

- Place the lift truck on flat, level ground with the wheels straight.

- Hold down the test button .

<p><b>STEP 1</b> ↓</p>	 <ul style="list-style-type: none"> <li>- A beep.</li> <li>- First green LED flashing.</li> <li>- Test button lit.</li> </ul>	<p>⇒</p>  <ul style="list-style-type: none"> <li>- Place the lift truck without any attachment, with the boom fully retracted and raised.</li> </ul>	<p>⇒</p> <p>Short press the test button. </p> <p>⇒</p> <p><b>TEST OK</b></p> <ul style="list-style-type: none"> <li>- Beeps once and progresses to stage 2.</li> </ul> <p><b>TEST NOT OK</b></p> <ul style="list-style-type: none"> <li>- Beeps twice and warning indicator lamp comes on .</li> <li>- Exit test mode.</li> <li>- Go to stage 4.</li> </ul>
<p><b>STEP 2</b> ↓</p>	 <ul style="list-style-type: none"> <li>- First green LED continuously lit.</li> <li>- Second green LED flashing.</li> <li>- Test button lit.</li> </ul>	<p>⇒</p>  <ul style="list-style-type: none"> <li>- Lower the boom with the engine running at full revs and the hydraulic control at the maximum setting. Slow lowering until movement is cut-off.</li> </ul>	<p>⇒</p> <p>Short press the test button. </p> <p>⇒</p> <p><b>TEST OK</b></p> <ul style="list-style-type: none"> <li>- Beeps once and progresses to stage 3.</li> </ul> <p><b>TEST NOT OK</b></p> <ul style="list-style-type: none"> <li>- Beeps twice and warning indicator lamp comes on .</li> <li>- Exit test mode.</li> <li>- Go to stage 4.</li> </ul>
<p><b>STEP 3</b> ↓</p>	 <ul style="list-style-type: none"> <li>- First and second green LEDs continuously lit.</li> <li>- Third green LED flashing.</li> <li>- Test button lit.</li> </ul>	<p>⇒</p> <ul style="list-style-type: none"> <li>- Lower the boom until the movement is cut off.</li> <li>- Request, in the following order: an excavation, dumping and a telescope boom extension. None of these 3 movements should be possible.</li> </ul>	<p>⇒</p> <p>Short press the test button. </p> <p>⇒</p> <p><b>TEST OK</b></p> <ul style="list-style-type: none"> <li>- Conformity of aggravating movement cut-off.</li> <li>- Exit test mode. All the LEDs will light for 2 seconds and a beep will sound.</li> </ul> <p><b>TEST NOT OK</b></p> <ul style="list-style-type: none"> <li>- Fault indicator lamp  comes on.</li> <li>- Exit test mode.</li> <li>- Go to stage 4.</li> </ul>
<p><b>STEP 4</b></p>	 <ul style="list-style-type: none"> <li>- The fault indicator goes out.</li> </ul>	<p>⇒</p> <ul style="list-style-type: none"> <li>- Pictogram  appears on the hour meter screen  and an audible beep is sounded.</li> <li>- Scroll through the error codes (↩ 2 - DESCRIPTION: 6B - SCREEN DISPLAYS: ERROR CODES).</li> <li>- If the error code "520393" is displayed, the problem may be resolved by resetting the longitudinal stability limiter and warning device (↩ OCCASIONAL SERVICE). Otherwise consult your dealer and provide the error code numbers.</li> </ul> <p>NOTE: For the stage 3 test, specify the non-compliant aggravating hydraulic movements, if necessary.</p>	

## ➔ 50H - WEEKLY SERVICE OR EVERY 50 HOURS OF SERVICE

### CHECK

#### Alternator/crankshaft belt tension

##### ⚠ IMPORTANT ⚠

*If the belt is changed, check the tension again after the first 20 hours of service.*

- Open the engine cover.
- Check the belt for signs of wear and cracks, and change if necessary (☞ FILTER ELEMENTS AND BELTS).
- Adjust the belt tension between the crankshaft pulley and the alternator pulley (98 N). The clearance should be about 7 to 9 mm.
- Adjust if necessary.
- Loosen screws 1 by two to three thread turns.
- Swivel the alternator assembly so as to obtain the required belt tension.
- Retighten screws 1 (tightening torque 22 N.m).

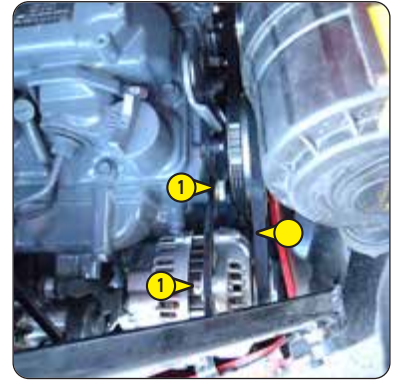

### CHECK

#### Compressor belt tension (Air conditioning option)

##### ⚠ IMPORTANT ⚠

*If the belt is changed, check the tension again after the first 20 hours of service.*

- Open the engine cover.
- Check the belt for signs of wear and cracks, and change if necessary (☞ FILTER ELEMENTS AND BELTS).
- Adjust the belt tension between the crankshaft pulley and the compressor pulley (98 N). The clearance should be about 7 to 9 mm.
- Adjust if necessary.
- Loosen screws 1 by two to three thread turns.
- Swivel the compressor assembly so as to obtain the belt tension required.
- Retighten screws 1 (tightening torque 22 N.m).



### CHECK

#### Transfer box oil level

Place the lift truck on level ground with the engine stopped.

- Visually check for any traces of seepage or leakage from the various filler, level and drain plugs.
- If there is any leakage or seepage, check the level.
- Remove the level plug 1, the oil should be flush with the edge of the hole.
- If necessary, add oil (☞ LUBRICANTS AND FUEL) by the same hole.
- Refit and tighten the level plug 1 (tightening torque 34 - 49 N.m).



### CHECK

#### Tyre pressures

### CHECK

#### Wheel nut tightening

##### ⚠ IMPORTANT ⚠

*Check that the air hose is correctly connected to the tyre valve before inflating and keep all persons at a distance during inflation. Follow the recommended tyre pressures.*

- Check the condition of the tyres, to detect cuts, blisters, wear, etc.
- Check the wheel nut tightening. Non-compliance with this instruction can lead to deterioration and breakage of the wheel bolts and distortion of the wheels.
- Check and restore tyre pressures if necessary (☞ 2 - DESCRIPTION: TYRES).

NOTE: There is an OPTIONAL wheel tool kit.

**CHECK**

**Front axle differential seal**

**CHECK**

**Rear axle differential seal**

Place the lift truck on level ground with the engine stopped.

- Visually check for any traces of seepage or leakage from the various filler, level and drain plugs.
- If there is any leakage or seepage, check the level.
- Remove the level plug 1, the oil should be flush with the edge of the hole.
- If necessary, add oil (<math>\leq</math> LUBRICANTS AND FUEL) by the same hole.
- Refit and tighten the level plug 1 (tightening torque 34 - 49 N.m).



**CHECK**

**Front wheel reducer seals**

**CHECK**

**Rear wheel reducer seals**

Place the lift truck on level ground with the engine stopped.

- Visually check for any traces of seepage or leakage from the level plug.
- If there is any leakage or seepage, check the level.
- Place level plug 1 in a horizontal position.
- Remove the level plug; the oil should be flush with the edge of the opening.
- If necessary, add oil (<math>\leq</math> LUBRICANTS AND FUEL) by the same hole.
- Refit and tighten the level plug (tightening torque 34 - 49 N.m).



**CHECK**

**Brake fluid level**

Place the lift truck on level ground.

**⚠ IMPORTANT ⚠**

*If the brake oil level is abnormal consult your dealer.*

- Open the protective casing 1 with the ignition key.
- Check tank 2. The correct level should be at the MAX. level on the tank.
- If necessary, add oil (<math>\leq</math> LUBRICANTS AND FUEL).
- Remove cap 3.
- Add oil through filler port.
- Refit the cap.
- Visually check that there is no leakage in the tank and pipes.



**CHECK**

**Boom pad slide pathways**

To preserve optimum operation, the pad slide pathways should be correctly lubricated:

**⚠ IMPORTANT ⚠**

**MANDATORY GREASING OF THE BOOM AFTER:**  
*Cleaning the boom, especially after using high pressure cleaner.*  
*The forklift has been unused for a long period of time.*

- Fully extend the boom.
- Check the condition of the surface of the pad slide pathways, surface run in (steel whitened) without traces of corrosion.
- If necessary lubricate the pad slide pathways (<math>\leq</math> LUBRICANTS AND FUEL).
- Telescope the boom several times in order to spread the lubricant evenly.
- Remove the surplus lubricant.

**⚠ IMPORTANT ⚠**

*If the lift truck is used in an abrasive environment (dust, sand, coal.) use lubricating varnish (MANITOU reference: 483536). Please consult your dealer.*



## CHECK

## Hydraulic oil level

Place the lift truck on level ground with the engine stopped, and the boom retracted and lowered as far as possible.

### ⚠ IMPORTANT ⚠

*Use a clean funnel and clean the underside of the oil drum before filling.*

- Pull out dipstick 1.
- Wipe the dipstick and check the correct oil level between the two marks on the dipstick.
- If necessary, add oil (⚠ LUBRICANTS AND FUEL).
- Remove the lock 2 on the cap 3.
- Remove cap 3.
- Add oil through filler port 4.
- Refit the cap 3 and its lock 2.
- Visually check that there is no leakage in the tank and pipes.



## CHECK

## Windscreen washer liquid level

- Open the protective casing 1 with the ignition key.
- Visually check the level in tank 2.
- If necessary add windscreen washer fluid (⚠ LUBRICANTS AND FUEL).
- Remove cap 3.
- Add windscreen washer liquid through filler port.
- Refit the cap.



## CLEAN

## Fuel pre-filter

### ⚠ IMPORTANT ⚠

*Carefully clean the outside of the pre-filter and its holder, to prevent dust from getting into the system.*

- Switch off the lift truck's ignition with the ignition key.
- Open the cover 1.
- Remove the cover 2.
- Disconnect the wiring harness 3.
- Place a receptacle under the plug 4.
- Unscrew the drain plug 4 by two thread turns.
- Allow the water and impurities to run out.
- Re-tighten the plug 4.
- Connect the electric wiring harness 3.
- Press several times on button 5 to pressurise the fuel circuit.
- Refit the cover 2.
- Close the cover 1.

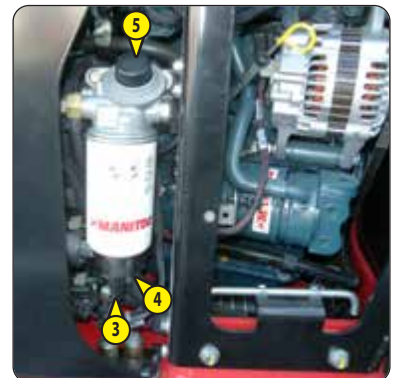
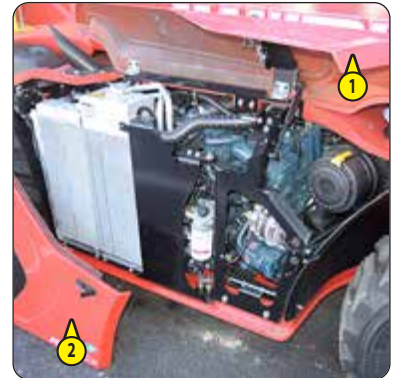

## CLEAN

### Radiator cores

#### **⚠ IMPORTANT ⚠**

*In a polluting atmosphere, clean the radiator cores every day. Do not use a water jet or high-pressure steam as this could damage the radiator fins.*

- Open the engine cover.
- Remove the side cover.
- Lift the lock 1.
- Rotate the radiator.
- Keep it in position with the lock 2.
- If necessary, clean the intake grille on the engine bonnet.
- Using a soft cloth, clean the radiator cores in order to remove as much dirt as possible.
- Clean the radiator using a compressed air jet aimed from the engine towards the radiator, in the opposite direction to the cooling air flow.
- Refit the unit.



## CLEAN

### Dry air filter cartridge

When used in very dusty atmospheres there are pre-filtration elements (≪ FILTER ELEMENTS AND BELTS). The cartridge checking and cleaning interval must also be reduced.

#### **⚠ IMPORTANT ⚠**

*If the clogging indicator lamp comes on, this operation must be carried out as soon as possible (within a maximum of 1 hour). Never use the lift truck without an air filter or with an air filter that is damaged.*

*Respect the safety distance of 30 mm between the air jet and the cartridge to avoid tearing or piercing the cartridge. The cartridge must not be blown near the air filter box. Never clean the cartridge by tapping it against a hard surface.*

*Your eyes must be protected during this intervention.*

*Never clean the dry air filter cartridge by washing it in liquid. Do not clean by any means the safety cartridge located inside the filter cartridge, change it for a new one if it is clogged or damaged.*

- For the dismantling and refitting of the cartridge (≪ 1000H: REPLACE Air filter cartridge).
- Clean the filter cartridge using a compressed air jet (max. pressure 3 bars) directed from the top to the bottom and from the inside towards the outside at a minimum distance of 30 mm from the cartridge wall.
- Cleaning is completed when there is no more dust on the cartridge.
- Clean the cartridge seal surface with a damp, clean lint-free cloth and grease with a silicone lubricant (MANITOU part No.: 479292).
- Check visually the outer condition of the air filter and its mounts. Verify the condition of the hoses and their mounts also.



## CLEAN

### Condenser wiring harness (Air conditioning OPTION)

#### **⚠ IMPORTANT ⚠**

*In a polluting atmosphere, clean the radiator core every day.*

*Do not use a water jet or high-pressure steam as this could damage the condenser fins.*

- Remove the protective grid 1 and clean it if necessary.
- Visually check whether the condenser is clean and clean it if necessary.
- Clean the condenser using a compressed air jet aimed in the same direction as the air flow.
- Clean with the fans running for best results.



To be carried out weekly, if the lift truck has been operated for less than 50 hours during the week.

**⚠ IMPORTANT ⚠**

*In the event of prolonged use in an extremely dusty or oxidising atmosphere, reduce this interval to 10 hours of service or every day.*

Clean, then lubricate the following points with grease (← LUBRICANTS AND FUEL) and remove the surplus.

**BOOM**

- 1 - Lubricators of the boom pin (1 lubricators).
- 2 - Lubricator of the carriage pin (1 lubricator).
- 3 - Lubricator of the tilting cylinder foot pin (1 lubricator).
- 4 - Lubricator of the tilting cylinder head pin (1 lubricator).
- 5 - Lubricator of the lifting cylinder foot pin (1 lubricator).
- 6 - Lubricator of the lifting cylinder head pin (1 lubricator).
- 7 - Lubricator of the compensating cylinder foot pin (1 lubricator).
- 8 - Lubricator of the compensating cylinder head pin (1 lubricator).

**FRONT AND REAR WHEEL REDUCTION GEAR PIVOTS**

- 9 - Lubricators of the wheel reduction gear pivot pins (8 lubricators).

**REAR AXLE OSCILLATION**

- 10 - Rear axle oscillation lubricators (1 lubricators).



## REPLACE

Engine oil \*

## REPLACE

Engine oil filter \*

Place the lift truck on level ground, let the engine run at idling speed for a few minutes, then stop the engine.

### ⚠ IMPORTANT ⚠

*Dispose of the drain oil in an ecological manner.*

*Tighten the oil filter by hand pressure only and lock the filter in place by a quarter turn.*

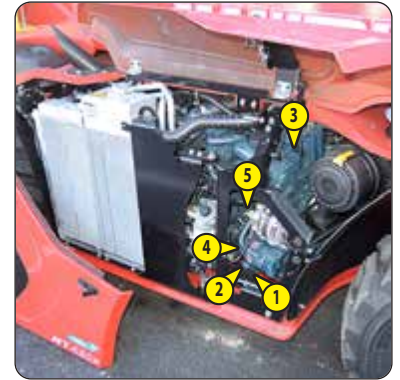

### DRAINING THE OIL

- Open the engine cover.
- Remove the side cover.
- Remove access panel 1.

NOTE: When removing cover plates and hatches, clean the surrounding area and remove any accumulations of flammable materials.

- Place a container under the drain hole and unscrew the drain plug 2.
- Remove the filler plug 3 to ensure correct drainage.

### REPLACEMENT OF THE FILTER

- Unscrew and discard the engine oil filter 4, together with its seal.
- Clean the filter bracket with a clean, lint-free cloth.
- Lightly oil the seal before refitting the new oil filter (⇐ FILTER ELEMENTS AND BELTS) on its bracket (tightening torque 15 - 17 N.m).

### FILLING WITH OIL

- Refit and tighten the drain plug 2.
- Fill up with oil (⇐ LUBRICANTS AND FUEL) through filler hole 3.
- Wait a few minutes to allow the oil to flow into the sump.
- Start the engine and let it run for a few minutes.
- Check for possible leaks from the drain plug and the oil filter.
- Stop the engine, wait a few minutes and check the correct level between the two marks on the dipstick 5.
- Top up the level if necessary.
- Refit the access cover 1.

*\* Only for the first 50 hours of service and then every 500 hours of service or 1 year.*

**CHECK**

**Condition of cables**

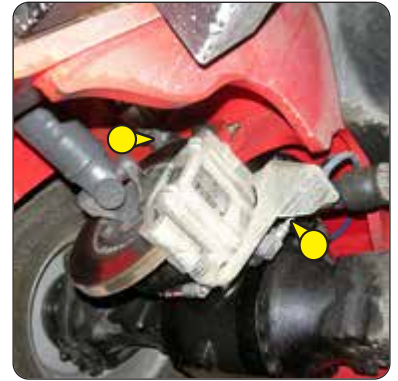

**CHECK**

**Hydraulic oil**

MANITOU offers a hydraulic oil analysis kit which might make it possible to delay the recommended deadline in the periodic maintenance schedule (2000 hours). In this case we recommend an analysis of the hydraulic oil every 500 hours or 1 year of service.

The oil analysis kit also makes it possible to confirm the oil quality so as to obtain a deadline of 2000 hours for specific uses causing constraints on the hydraulic circuit: extreme environmental conditions, use of the attachments with a very high hydraulic flow rate (such as a sweeper, or a concrete mixer).

- Order an oil analysis kit from your dealer.
- Upon receiving the kit, take a sample of oil and follow the instructions shown on the kit.
- According to the results, keep the analysis report or replace the hydraulic oil.

**MANITOU oil analysis kit Part No. 958162.**



**LUBRICATE**

**Engine cover opening**

- Open the engine cover.
- Clean then lubricate the hinges 1 and the engine cover locking system 2 with multi-purpose lubricant (↖ LUBRIFIANTS AND FUEL).

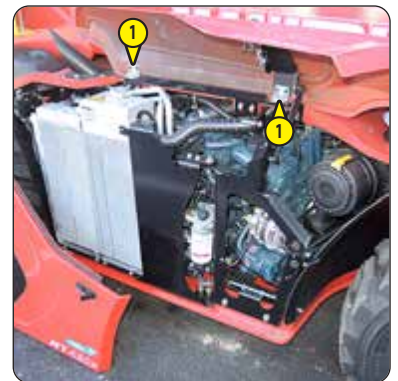

## REPLACE

## Engine oil

## REPLACE

## Engine oil filter

Place the lift truck on level ground, let the engine run at idling speed for a few minutes, then stop the engine.

### ⚠ IMPORTANT ⚠

*Dispose of the drain oil in an ecological manner.*

*Hand tighten the oil filter only and lock the filter in place by a quarter turn.*

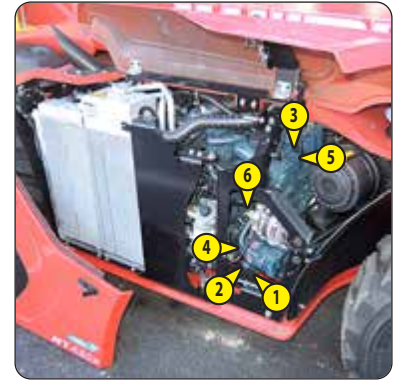

### DRAINING THE OIL

- Open the engine cover.
- Remove access panel 1.

NOTE: When removing cover plates and hatches, clean the surrounding area and remove any accumulations of flammable materials.

- Place a container under the drain hole and unscrew the drain plug 2.
- Remove the filler plug 3 to ensure correct drainage.

### REPLACEMENT OF THE FILTER

- Unscrew and discard the engine oil filter 4, together with its seal.
- Clean the filter bracket with a clean, lint-free cloth.
- Lightly oil the seal before refitting the new oil filter (⇐ FILTER ELEMENTS AND BELTS) on its bracket (tightening torque 15 - 17 N.m).

### FILLING WITH OIL

- Refit and tighten the drain plug 1.
- Fill up with oil (⇐ LUBRICANTS AND FUEL) through filler hole 5.
- Wait a few minutes to allow the oil to flow into the sump.
- Start the engine and let it run for a few minutes.
- Check for possible leaks from the drain plug and the oil filter.
- Stop the engine, wait a few minutes and check the correct level between the two marks on the dipstick 6.
- Top up the level if necessary.
- Refit the access cover 1.

## REPLACE

## Fuel filter

### ⚠ IMPORTANT ⚠

*Carefully clean the outside of the filter and around it, to prevent dust from getting into the system.  
Tighten the filter by hand only and lock it by a quarter turn.*

- Switch off the lift truck's ignition with the ignition key.
- Lift the lock 1.
- Rotate the radiator 2.
- Keep it in position with the lock 3.
- Unscrew the filter 4.
- Clean the inside of the filter head using a brush immersed in clean diesel oil.
- Refit a new filter lubricated with clean diesel beforehand (◀ FILTER ELEMENTS AND BELTS).
- Replace the fuel pre-filter.

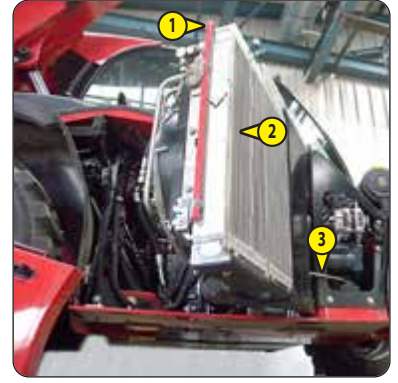

## REPLACE

## Fuel pre-filter

### ⚠ IMPORTANT ⚠

*Carefully clean the outside of the filter and around it, to prevent dust from getting into the system.  
Tighten the filter by hand only and lock it by a quarter turn.*

- Disconnect the wiring harness 1.
- Place a receptacle under the filter 2.
- Unscrew the filter 2.
- Clean the inside of the filter head using a brush immersed in clean diesel oil.
- Refit a new filter lubricated with clean diesel beforehand (◀ FILTER ELEMENTS AND BELTS).
- Reconnect the wiring harness 1.
- Open bleed screws 3 and 4.
- Turn on the lift truck's ignition with the ignition key.
- Close the bleed screws 3 and 4 as soon as the diesel flows free of air.

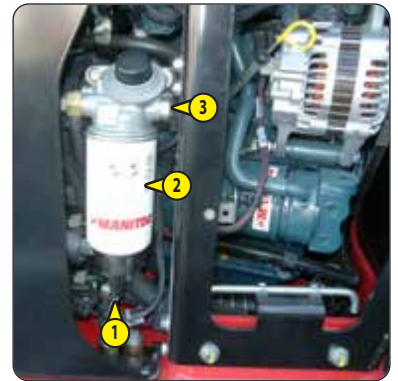

## REPLACE

### Hydraulic return oil filter cartridge

Stop the engine and release the pressure from the systems by operating the hydraulic controls.

#### ⚠ IMPORTANT ⚠

*Carefully clean the outside of the filter and around it, to prevent dust from getting into the system.  
Tighten the filter by hand only and lock it by a quarter turn.*

- Remove access panel 1.

NOTE: When removing cover plates and hatches, clean the surrounding area and remove any accumulations of flammable materials.

- Place a container under access panel 1.
- Unscrew the body of the filter 2.
- Remove the hydraulic return oil filter cartridge and replace with a new one (↔ FILTER ELEMENTS AND BELTS).
- Before replacing the cartridge, clean the inside of the filter body with a clean, lint-free cloth.
- Make sure that the cartridge is correctly positioned and refit the body of the filter.

#### FILLING WITH OIL

- Start the engine and let it run for a few minutes.
- Visually check that there is no leakage in the tank and pipes.
- Stop the engine, wait a few minutes and check the correct level between the two level marks on the dipstick 3.
- Remove the lock 4.
- Remove the cap 5.
- Fill up with oil (↔ LUBRICANTS AND FUEL) through filler hole 6.
- Observe the oil level on dipstick 3; the oil level should be between the two marks.
- Refit the filler cap 5 and its lock 4.
- Refit the access cover 1.
- Remove the lock 7.
- Rotate the radiator 8.
- Push to lock 9.
- Refit the side cover 10.
- Close the engine cover 11.

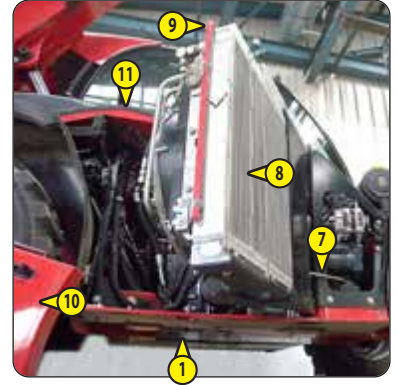

## REPLACE

### Cab fan filter

#### INTERNAL CAB VENTILATION FILTER

- Remove the protective grid 1.
- Remove the cab ventilation filter and replace it with a new one (↔ FILTER ELEMENTS AND BELTS).
- Refit the protective grid.

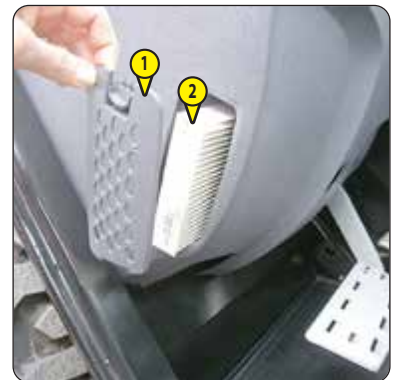

**⚠ IMPORTANT ⚠**

*Operate the battery cut-off no less than 30 seconds after having switched off the ignition with the ignition key.*

*Handling a 12V battery can be dangerous. Take the following precautions:*

- *Wear protective goggles.*
- *Keep the 12V battery horizontal.*
- *Never smoke or direct a naked flame toward the batteries.*
- *The batteries are not charged in an explosive environment.*
- *Do not leave the battery charger connected during an electrical storm.*

*In the event of electrolyte being spilled onto the skin or splashed in the eyes, rinse thoroughly with cold water for 15 minutes and call a doctor.*

To prolong battery life, MANITOU recommends fully recharging the 12 V battery a few months before the start of the winter season.

- Open the engine hood.
- Disconnect the 12 V battery in the following order: negative (-) terminal first, then positive (+) terminal.
- Fully charge the battery.
- Reconnect the 12 V battery in the following order: positive (+) terminal first, then negative (-) terminal.
- Close the engine hood.

**CHECK** *Hoses and differential pressure hoses for the exhaust particle filter "DPF" \*\**

**CHECK** *Exhaust gas recirculation piping "EGR" \*\**

**CHECK** *Intake hose \*\**

**CHECK** *\*\*Exhaust manifold*

**CHECK** *Fork wear \**

**\*\* Engine service, consult your dealer.**

**\* Consult your dealer.**



## 🔄 1000H - PERIODIC SERVICE - EVERY 1000 HOURS OF SERVICE OR 2 YEARS

ALSO PERFORM THE 500 HOUR PERIODIC MAINTENANCE OPERATIONS.

### CHECK

### Safety belt

#### ⚠️ IMPORTANT ⚠️

*Under no circumstances must the lift truck be used if the seat belt is defective (fixing, locking, cuts, tears, etc.).  
Immediately repair or replace the safety belt.*

#### SEAT BELT WITH TWO ANCHORING POINTS

- Check the following points:
  - Fixing of the anchoring points on the seat.
  - Cleanness of the strap and the locking mechanism.
  - Triggering of the locking mechanism.
  - Condition of the strap (cuts, curled edges).

#### REELED SEAT BELT WITH TWO ANCHORING POINTS

- Check the points listed above together with the following points:
  - The correct winding of the belt.
  - Condition of the reel guards.
  - Roller locking mechanism when the strap is given a sharp tug.

NOTE: After an accident, replace the seat belt.

### CLEAN

### Fuel tank

Place the lift truck on level ground with the engine stopped.

#### ⚠️ IMPORTANT ⚠️

*While carrying out these operations, do not smoke or work near a flame.*

*Never try to carry out a weld or any other operation by yourself, this could provoke an explosion or a fire.*

- Inspect the parts of the fuel circuit and the tank liable to leak, both visually and by touch.
- In the event of a leak, contact your dealer.
- Place a container under drain plug 1 and unscrew the plug.
- Remove the filler plug 2 to ensure correct drainage.
- Rinse with ten litres of clean diesel through filler hole 2.
- Refit and tighten the drain plug 1 (tightening torque 29 - 39 N.m).
- Fill the fuel tank with clean diesel filtered through the filler port.
- Refit the filler plug.



## REPLACE

## Alternator belt

### ⚠ IMPORTANT ⚠

*Check the belt tension again after the first 20 hours of service.*

- Open the engine cover.

### REMOVING THE BELT

- Loosen screws 1 by two to three thread turns.
- Swivel the alternator assembly so as to free belt 2.
- Remove the alternator belt 2.

NOTE: Take advantage of belt removal to check the correct operation of the pulleys and bearings (noise, rubbing, play, etc.).

### REFITTING THE BELT

- Refit a new alternator belt (↖ FILTER ELEMENTS AND BELTS). Ensure that it is properly seated in the grooves of each pulley.
- Adjust the belt tension between the crankshaft pulley and the alternator pulley (98 N). The clearance should be about 7 to 9 mm.
- Swivel the alternator assembly so as to obtain the required belt tension.
- Retighten screws 1 (tightening torque 22 N.m).



## REPLACE

## Engine crankcase ventilation filter

- Open the engine cover.
- Carefully clean the outside of the filter and its holder, to prevent dust from getting into the system.
- Disconnect the hose 1 at the filter.
- Unscrew the cover 2.
- Take out the filter 3 and discard it together with the seal of the cover 2.
- Refit a new seal on the cover and insert a new filter (↖ FILTER ELEMENTS AND BELTS).
- Put back the cover 2 and tighten by hand only and lock by a quarter turn.
- Reconnect hose 1.



## REPLACE

## Dry air filter cartridge

In case of use in a heavily dust laden atmosphere, there are pre-filtration cartridges, (⇐ FILTER ELEMENTS AND BELTS). Also, the checking and cleaning periodicity of the cartridge must be reduced (up to 250 hours in a very dusty atmosphere and with pre-filtration).

### ⚠ IMPORTANT ⚠

*Change the cartridge in a clean location, with the engine stopped. Never operate the lift truck with the air filter removed or damaged.*

- Open the engine cover.
- Loosen the locks and remove cover 1.
- Gently remove the cartridge 2 to reduce dust falling as far as possible.
- Leave the safety cartridge in place.
- Carefully clean the following parts with a damp, clean lint-free cloth.
  - The inside of the filter and cover.
  - The inside of the filter inlet hose.
  - The gasket surfaces in the filter and in the cover.
- Check pipes and connections between the air filter and the engine and the connection and state of the clogging indicator on the filter.
- Before fitting check the condition of the new cartridge (⇐ FILTER ELEMENTS AND BELTS).
- Insert the cartridge in the filter axis and push the cartridge pressing against the outer edge and not the centre.
- Reassemble the cover, guiding the valve downwards.



## REPLACE

## Coolant

These operations are to be carried out as necessary or every 2 years at the beginning of winter. Place the lift truck on level ground with the engine stopped and cold.

### ⚠ IMPORTANT ⚠

*The engine does not contain any anti-corrosion element and must be filled with a mixture containing 25% of ethylene glycol-based antifreeze all year round.*

### DRAINING THE LIQUID

- Open the engine cover.
- Remove the side cover.
- Lift the lock 1.
- Rotate the radiator.
- Keep it in position with the lock 2.
- Place a container under drain plug 3 and unscrew the plug.
- Remove the filler plug 4.
- Let the cooling circuit drain entirely while ensuring that the ports do not get clogged.
- Check the condition of the hoses as well as the fastening devices and change the hoses if necessary.
- Rinse the circuit with clean water and use a cleaning agent if necessary.

### FILLING WITH COOLANT

- Refit and tighten the radiator drain plug 3 (tightening torque 30 N.m).
- Slowly fill the system with the coolant (⇐ MAINTENANCE: LUBRICANTS AND FUEL) through the filler hole 4.
- Check dipstick 5, the correct level must stand at the level of the red point.
- Refit the filler plug 4.
- Run the engine at idle for a few minutes.
- Check for any possible leaks.
- Check the level and refill if necessary.

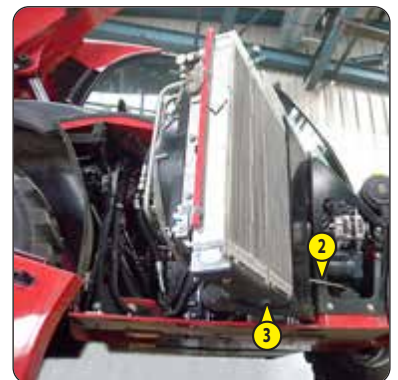
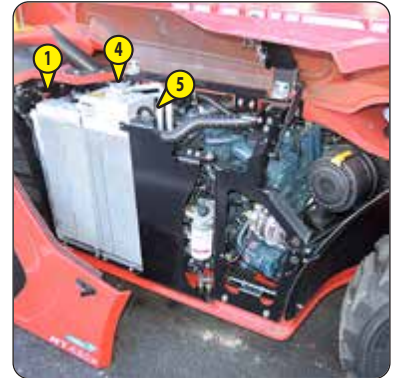

## REPLACE

## Transfer box oil

Place the lift truck on level ground with the engine stopped and the transfer box oil still warm.

### ⚠ IMPORTANT ⚠

*Dispose of the drain oil in an ecological manner.*

- Place a container under drain plug 1 and unscrew the plug.
- Remove level and filling plug 2 to ensure correct drainage.
- Refit and tighten the drain plug 1 (tightening torque 34 - 49 N.m).
- Fill up with oil (⚡ LUBRICANTS AND FUEL) through filler hole 2.
- The level is correct when the oil level is flush with the edge of the hole.
- Check for any possible leaks at the drain plug.
- Refit and tighten the level and filling plug 2 (tightening torque 34 - 49 N.m).



## REPLACE

## Front axle differential oil

## REPLACE

## Rear axle differential oil

Place the lift truck on level ground with the engine stopped and the still warm differential oil.

### ⚠ IMPORTANT ⚠

*Dispose of the drain oil in an ecological manner.*

- Place a container under drain plug 1 and unscrew the plug.
- Remove level and filling plug 2 to ensure correct drainage.
- Refit and tighten the drain plug 1 (tightening torque 34 - 49 N.m).
- Fill up with oil (⚡ LUBRICANTS AND FUEL) through filler hole 2.
- The level is correct when the oil level is flush with the edge of the hole.
- Check for any possible leaks at the drain plug.
- Refit and tighten the level and filling plug 2 (tightening torque 34 - 49 N.m).



## REPLACE

## Front wheel reducer oil

## REPLACE

## Rear wheel reducer oil

Place the lift truck on level ground with the engine stopped and the reducers' oil still warm.

### ⚠ IMPORTANT ⚠

*Dispose of the drain oil in an ecological manner.*

- Drain and change the oil of each wheel reduction gear.
- Place drain plug 1 in position A.
- Place a container under the drain plug and unscrew the plug.
- Let the oil drain fully.
- Place the drain port in position B, i.e. in a level port.
- Fill up with oil (⚡ LUBRICANTS AND FUEL) through level hole 1.
- The level is correct when the oil level is flush with the edge of the hole.
- Refit and tighten the drain plug (tightening torque 34 - 49 N.m).



<b>CHECK</b>	<b>Silentblocks **</b>
<b>CHECK</b>	<b>Valve lash **</b>
<b>CHECK</b>	<b>Injectors **</b>
<b>CHECK</b>	<b>Exhaust gas recirculation cooler "EGR" **</b>
<b>CHECK</b>	<b>Casing gas recycling valve **</b>
<b>CHECK</b>	<b>Brake system pressure *</b>
<b>CHECK</b>	<b>Boom pad wear *</b>
<b>CHECK</b>	<b>Condition of wiring harnesses and cables *</b>
<b>CHECK</b>	<b>Lights and signals *</b>
<b>CHECK</b>	<b>Warning indicators *</b>
<b>CHECK</b>	<b>Condition of the rear-view mirrors *</b>
<b>CHECK</b>	<b>Cabin structure *</b>
<b>CHECK</b>	<b>Frame structure *</b>
<b>CHECK</b>	<b>Attachment carriage *</b>
<b>CHECK</b>	<b>Condition of attachments *</b>
<b>REPLACE</b>	<b>Brake fluid *</b>
<b>BLEED</b>	<b>Brake circuit *</b>
<b>ADJUST</b>	<b>Brake *</b>

**\*\* Engine service, consult your dealer.**

**\* Consult your dealer.**



## 🔄 2000H - PERIODIC SERVICE - EVERY 2000 HOURS OF SERVICE OR 4 YEARS

ALSO PERFORM THE 500 HOUR AND 1000 HOUR PERIODIC MAINTENANCE OPERATIONS.

### CHECK

### Wheel nut tightening torques

- Check the condition of the tyres, to detect cuts, blisters, wear, etc.
- Check the tightening torque of the wheel nuts with a torque wrench.
  - Front wheels: 340 N.m  $\pm$  51 N.m
  - Rear wheels: 340 N.m  $\pm$  51 N.m

### REPLACE

### Dry air filter safety cartridge

#### ⚠ IMPORTANT ⚠

*The safety cartridge replacement frequency is given for information only. It must be changed every second time the dry air filter cartridge is changed.*

- For the dismantling and refitting of the cartridge (<math>\leq 1000</math> HOURS: REPLACE Air filter cartridge).
- Remove the dry air filter safety cartridge 1 carefully, to minimise dust fall.
- Clean the gasket surface on the filter with a damp, clean lint-free cloth.
- Check the condition of the new safety cartridge before fitting (<math>\leq</math> FILTER ELEMENTS AND BELTS).
- Insert the cartridge in the filter axis and push the cartridge pressing against the outer edge and not the centre.



## REPLACE

## Hydraulic oil

## REPLACE

## Brake accumulator unit filter

Place the lift truck on level ground with the engine stopped.

### ⚠ IMPORTANT ⚠

*Raise the boom and place the boom safety wedge on the rod of the lifting cylinder (⇐ 1 - INSTRUCTIONS AND SAFETY RECOMMENDATIONS: LIFT TRUCK MAINTENANCE INSTRUCTIONS).*

*Before any intervention, thoroughly clean the area surrounding the drain and filler plugs.*

*Dispose of the drain oil in an ecological manner.*

*Use a very clean container and funnel and clean the underside of the oil drum before filling.*

### DRAINING THE OIL

- Open the engine cover 1.
- Remove the side cover 2.
- Lift the lock 3.
- Rotate the radiator.
- Keep it in position with the lock 4.
- Place a container under drain plugs 5 and unscrew them.
- Remove the filler cap lock 6.
- Remove the filler plug 7 to ensure correct drainage.
- Open the rear cover 8.

### REPLACING THE VENTILATION CONTROL BLOCK FILTER

- Unscrew the filter 16 and replace with a new one (⇐ FILTER ELEMENTS AND BELTS) (tightening torque 25,8 - 28,5 N.m).

### REPLACING THE BREATHER

- Unscrew the breather 10 and replace it with a new one (⇐ FILTER ELEMENTS AND BELTS).

### REPLACING THE BRAKE ACCUMULATOR UNIT FILTER

- Remove engine cover 1 and the cover plate 11.
- Place a container under access panel 12 and unscrew it.

NOTE: When removing cover plates and hatches, clean the surrounding area and remove any accumulations of flammable materials.

- Unscrew plug 13, remove and replace the filter with a new one (⇐ FILTER ELEMENTS AND BELTS).
- Refit and tighten the plug 13 (tightening torque 70 - 80 N.m).
- Refit the access cover 12.

### FILLING WITH OIL

- Clean and refit the drain plugs 5 (tightening torque 29 - 39 N.m).
- Fill up with oil (⇐ LUBRICANTS AND FUEL) through filler hole 14.
- Observe the oil level on dipstick 15; the oil level should be between the two marks.
- Check for any possible leaks at the drain plugs.
- Refit the filler cap 7 and its lock 6.

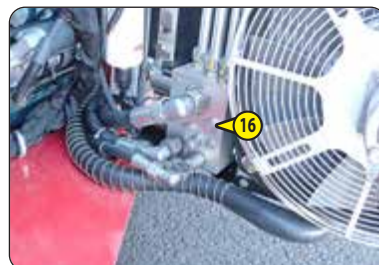
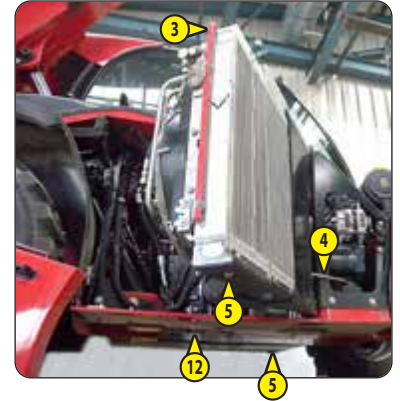
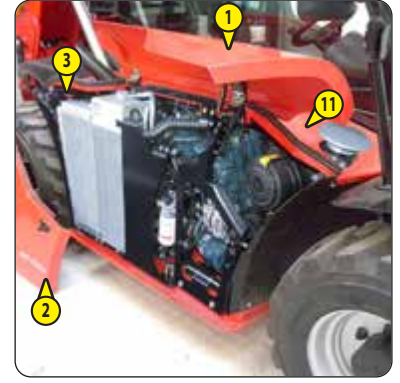

<b>CHECK</b>	<b>Radiator *</b>
<b>CHECK</b>	<b>Transmission pressures *</b>
<b>CHECK</b>	<b>Steering *</b>
<b>CHECK</b>	<b>Steering swivel joints *</b>
<b>CHECK</b>	<b>Brake pad and brake disk wear *</b>
<b>CHECK</b>	<b>Condition of boom assembly *</b>
<b>CHECK</b>	<b>Bearings and bushings *</b>
<b>CHECK</b>	<b>Condition of hoses and flexible pipes *</b>
<b>CHECK</b>	<b>Condition of cylinders (leakage, rods) *</b>
<b>CHECK</b>	<b>Hydraulic circuit pressures *</b>
<b>CLEAN</b>	<b>Air conditioning (OPTION) *</b>
<b>REPLACE</b>	<b>Compressor belt (Air Conditioning OPTION) *</b>

**\* Consult your dealer.**

➔ ④ 3000H - PERIODIC SERVICE - EVERY 3000 HOURS OF SERVICE OR 6 YEARS

ALSO PERFORM THE 500 HOUR AND 1000 HOUR PERIODIC MAINTENANCE OPERATIONS.

**CHECK** **Turbocharger** \*\*

---

**CHECK** **Exhaust gas recirculation system "EGR"** \*\*

---

**CLEAN** **Exhaust particle filter "DPF"** \*\*

---

**\*\* Engine service, consult your dealer.**





### CLEAN

### "Stationary lift truck" exhaust purification

#### ⚠ IMPORTANT ⚠

Exhaust purification is an automated procedure activated by the operator when the following indicator lamps are displayed:



- Park the lift truck in a safe and adequately ventilated place.
- Check the following points:
  - forward/reverse selector in neutral,
  - parking brake applied,
  - boom angle less than 5°,
  - accelerator pedal released,
  - hand throttle not used (option),
- Check that the fuel level is sufficient.
- Start the lift truck and run the engine for a few minutes to bring it up to its operating temperature.
- Press the top of switch 1 for more than two seconds to begin the regeneration procedure.
- Lighting of the indicator lamp  plus a beep conforms the start of the "stationary lift truck" exhaust purification procedure.
- The "wait" display will flash throughout the 'stationary lift truck' exhaust purification.
- Otherwise, "notice" will be displayed for 3 seconds indicating a fault in the procedure. In this event check the positioning of the lift truck and contact your dealer if necessary.
- At the end of the procedure, indicator lamps  +  go out.
- During the procedure the engine speed increases to approx. 1800 rpm, and the indicator lamp  comes on when the exhaust particle filter gases reach a high temperature.



#### ⚠ IMPORTANT ⚠

*The exhaust sublimation procedure must only be stopped if absolutely necessary.*

*The procedure stops automatically if the operator:*

- activates the hydraulic control joystick,
- engages forward or reverse gear,
- switches off the engine,
- or pressing on the top of the switch 1.

- The time taken for exhaust purification varies (between 15 and 30 minutes) according to several criteria, such as:
  - the level of clogging of the filter,
  - the ambient temperature,
  - the fuel quality and type of engine oil,
  - the number of exhaust particle filter automatic regeneration requests previously cancelled.
- The engine will return to its initial idling speed to indicate that the procedure has finished.

#### ⚠ IMPORTANT ⚠

*Once the exhaust sublimation procedure is completed, leave the engine idling for a few minutes to lower the temperature before switching off the ignition.*

## REPLACE

## Wheels

For this operation, we advise you to use the MANITOU hydraulic jack Part No. 505507 and the MANITOU safety support prop Part No. 554772.

### ⚠ IMPORTANT ⚠

*In the event of a wheel being changed on the public highway, secure the lift truck vicinity:*

- Stop the lift truck, if possible on firm, level ground.
- Stop the lift truck (☞ 1 - OPERATING AND SAFETY INSTRUCTIONS: DRIVING INSTRUCTIONS UNLADEN AND LADEN).
- Switch on the hazard warning lights.
- Immobilise the lift truck in both directions on the axle opposite to the wheel to be changed.
- Unlock the nuts of the wheel to be changed.
- Place the jack under the flared axle tube, as near as possible to the wheel and adjust the jack.
- Raise the wheel until it is clear of the ground and place the safety support under the axle.
- Completely unscrew the wheel nuts and remove them.
- Free the wheel by reciprocating movements and roll it to the side.
- Slip the new wheel on the wheel hub.
- Hand-tighten the nuts, grease them if necessary.
- Remove the safety support and lower the lift truck with the jack.
- Tighten the wheel nuts with a torque wrench (☞ 2000H - PERIODIC SERVICE - EVERY 2000 HOURS OF SERVICE OR EVERY 4 YEARS) for the tightening torque.



## ADJUST

## Front headlights

### RECOMMENDED SETTING

(as per standard ECE-76/756 76/761 ECE20)

Adjustment of -2 % of the dipped beam harness relative to the horizontal axis of the headlight.

### ADJUSTMENT PROCEDURE

- Place the unladen lift truck in the transport position and perpendicular to a white wall on flat, level ground.
- Check the tyre pressures (☞ 2 - DESCRIPTION: TYRES).
- Place the forward/reverse selector in neutral.

### CALCULATING THE HEIGHT OF THE DIPPED BEAM (H2)

- h1 = Height of the dipped beam in relation to the ground.
- h2 = Height of the adjusted beam.
- l = Distance between the dipped beam and the white wall.

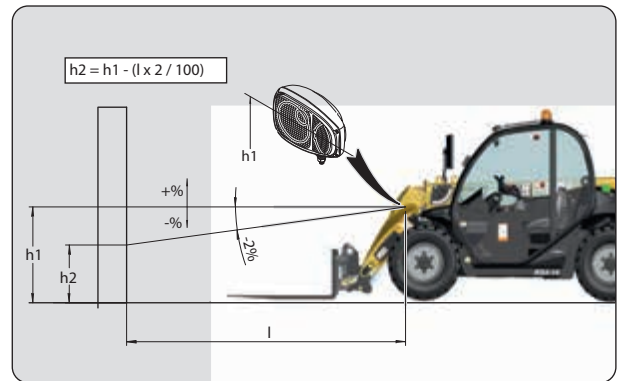

According to the use of the lift truck, the device may require to be periodically reset.









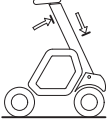

This operation can be easily performed by means of the following procedure.

- Provide a fork carrier or a bucket and a load corresponding to at least half the lift truck's rated capacity.
- Preferably perform the reset when the lift truck is still cold (before it is used) or ensure that the temperature of the rear axle is not more than 50°C.
- Place the lift truck on flat, level ground with the wheels straight.

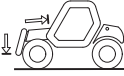
**⚠ IMPORTANT ⚠**

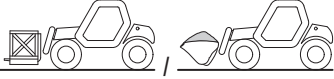
Strictly adhere to the boom positioning instructions. Two beeps and lighting of the fault indicator lamp  informs you these instructions have not been following. If in doubt consult your dealer.

When the reset is completed, check the operation of the longitudinal stability limiter and warning device (⏪ 10H - DAILY SERVICE OR EVERY 10 HOURS OF SERVICE).

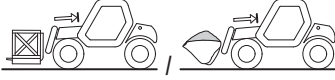
<p><b>STEP 1</b> <b>ENTRY</b></p> <p>↓</p>	 <p>→</p> <p><b>Simultaneously press and hold down the "BUCKET" MODE  and TEST  buttons.</b></p> <ul style="list-style-type: none"> <li>- Without attachments.</li> <li>- Boom fully retracted and raised.</li> <li>- Two beeps will sound and all the LEDs will flash twice to confirm the start of the procedure.</li> </ul>
<p><b>STEP 2</b></p> <p>↓</p>	 <p>→</p>  <p>→</p> <p><b>Short press the test button.</b></p>  <ul style="list-style-type: none"> <li>- Without attachments.</li> <li>- Carriage tilted fully backwards.</li> <li>- Boom fully retracted and in the down position a few centimetres off the ground.</li> </ul>
<p><b>STEP 3</b></p> <p>↓</p>	 <p>→</p>  <p>→</p> <p><b>Short press the test button.</b></p>  <p>→</p> <p><b>Two beeps will sound and all the LEDs will flash twice to confirm the end of the procedure.</b></p> <ul style="list-style-type: none"> <li>- With the fork carrier or the bucket and a load (keep boom retracted to allow all other hydraulic movements).</li> <li>- Boom fully retracted and in the down position a few centimetres off the ground.</li> </ul> <p><b>⚠ IMPORTANT ⚠</b></p> <p><b>Always keep the load as close to the ground as possible during this operation.</b></p> <ul style="list-style-type: none"> <li>- Hold down the disable the "aggravating" hydraulic movement cut-off button  (indicator lamp lit), and telescope the boom until the rear wheels leave the ground.</li> </ul> <p>NOTE: This stage consists in unloading the rear axle. It can be done using a jack but without bearing on the rear axle.</p> 
<p><b>STEP 4</b> <b>EXIT</b></p>	 <p>→</p>  <ul style="list-style-type: none"> <li>- After completing the resetting procedure, the lift truck is in an overloaded condition. Retract the telescope to restore the situation.</li> <li>- All LEDs lit.</li> <li>- A continuous audible beep.</li> </ul>

## CHECK

## Disabling "AGGRAVATING" hydraulic movement cut-off

ONLY FOR AUSTRALIA

This operation can be easily performed by means of the following procedure.

### ⚠ IMPORTANT ⚠



*In case of incorrect setting, consult your dealer.*

#### LIFT TRUCK ON LEVEL GROUND

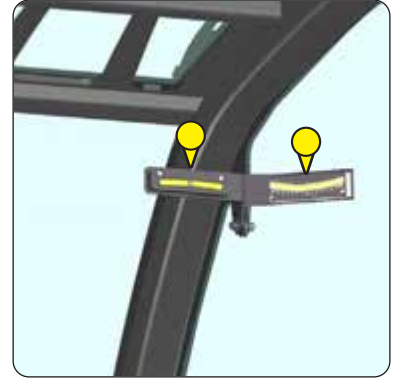
- Place the lift truck on flat and level ground with the wheels straight.
- Lower down the boom into transport position.
- Check lift truck horizontality on level indicators.



#### BOOM ANGLE

- Slowly lift the boom, stop hydraulic movement as soon as light  goes out, and check the lift angle ( $< 10^{\circ} - 2^{\circ}$ ) on the boom.
- Slowly lower down the boom and stop hydraulic movement as soon as light  goes on.

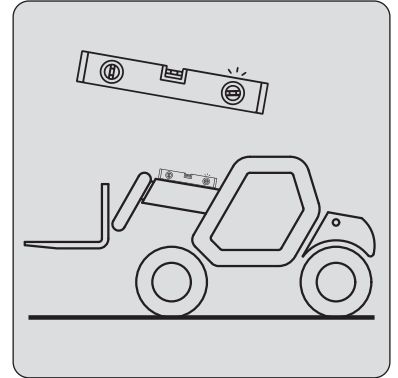

#### BOOM EXTENSION

- Slowly extend the boom, stop hydraulic movement as soon as light  goes out and check extension (1000 mm  $-200$  mm).

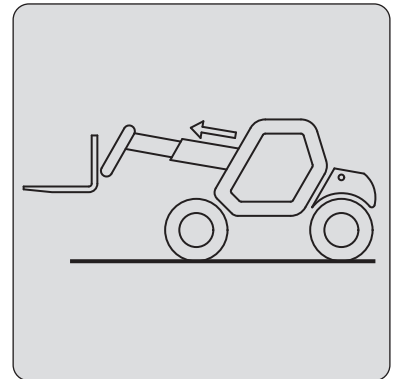

### TOW OR WINCH

### Lift truck

#### ⚠ IMPORTANT ⚠

*If the lift truck is not on level ground, chock it so that it does not descend the slope.*

*The lift truck must be towed very slowly (less than 5 km/h) and for as short a distance as possible (less than 100 m).*

For towing a lift truck, the high pressure limiters must be unlocked to avoid damaging the hydrostatic transmission, and the parking brake on the front axle must be released.

- Switch on lift truck ignition.
- Set the forward/reverse selector to neutral.
- Disconnect the parking brake.

#### UNLOCKING THE HIGH PRESSURE LIMITERS

- Open the engine cover.
- Remove the side cover 1.
- Lift the lock 2.
- Rotate the radiator.
- Keep it in position with the lock 3.
- Loosen nuts 4 on the hydrostatic pump by no more than three turns.

#### RELEASING THE PARKING BRAKE

- Press button 5 several times until pressing becomes difficult.
- This enables the brake disc to be released.

#### TOWING

- Switch on the hazard warning lights.
- Since there will be no steering or braking hydraulic assistance, operate the steering and pedal slowly, avoiding sudden or jerky movements.
- After towing, re-tighten nuts 4 (tightening torque 70 N.m).
- Pressing button 6 will enable the parking brake to be reactivated.

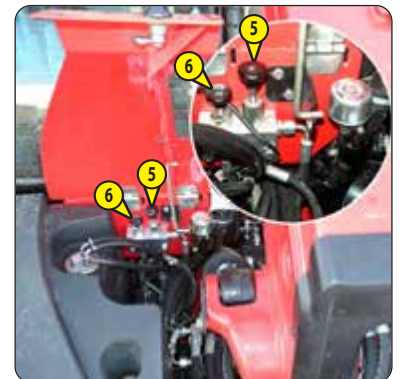

Tools: 5 x 3 ton shackles.

3 x 3 ton straps, length 3 metres.

- Place the lift truck in the transport position, with the boom lowered.
- Install the shackles 1 and the straps 2 as shown below in the anchorage points 3.
- The straps at the front of the lift truck must pass between the boom and the cab.
- Lift the lift truck.
- The lift truck swivels on the left side and stabilises resting on the strap at point 4.

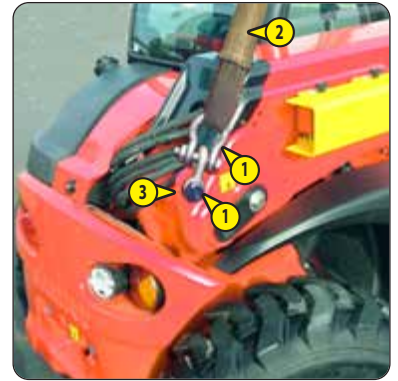
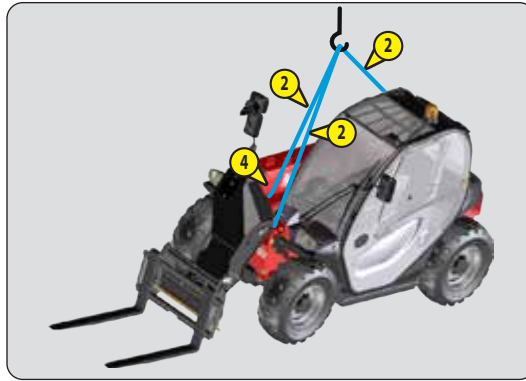
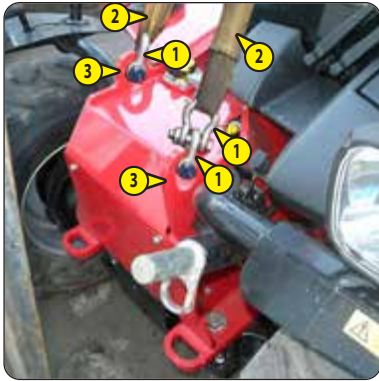

**⚠ IMPORTANT ⚠**

Ensure that the safety instructions associated with the flatbed are complied with before loading the lift truck and that the driver of the carrier vehicle is informed of the dimensions and the weight of the lift truck (<math>\leq 2 - DESCRIPTION: CHARACTERISTICS</math>).

Ensure that the platform is of sufficient size and load capacity for transporting the lift truck.  
Check also the allowable ground contact pressure of the platform relative to the lift truck.

**⚠ IMPORTANT ⚠**

For lift trucks equipped with a turbo-charged engine, block off the exhaust outlet to avoid rotation of the turbo shaft without lubrication when transporting the vehicle.

**LOADING THE LIFT TRUCK**

- Block the wheels of the platform.
- Attach the loading ramps to the platform in such a way as to give the shallowest possible ramp angle for the lift truck.
- Load the lift truck parallel to the platform.
- Stop the lift truck (<math>\leq 1 - OPERATING AND SAFETY INSTRUCTIONS: DRIVING INSTRUCTIONS UNLADEN AND LADEN</math>).

**STOWING THE LIFT TRUCK**

- Fix the chocks to the platform at the front and at the back of each tyre.
- Also fix the chocks to the platform on the inside of each tyre.
- Secure the lift truck to the platform with sufficiently strong ropes to the anchoring points 1 provided.
- Tighten the ropes.

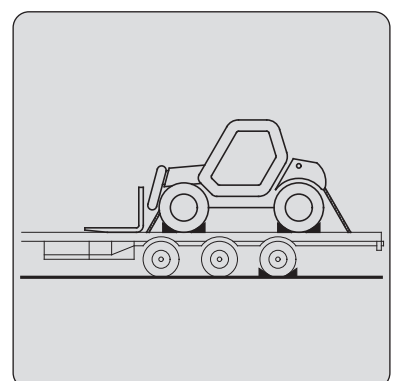
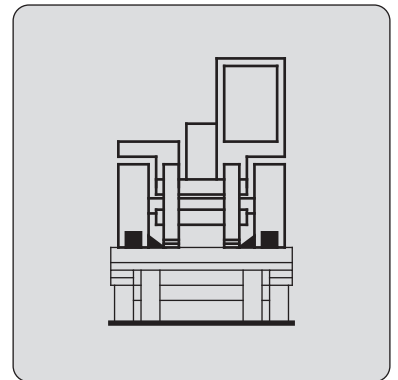
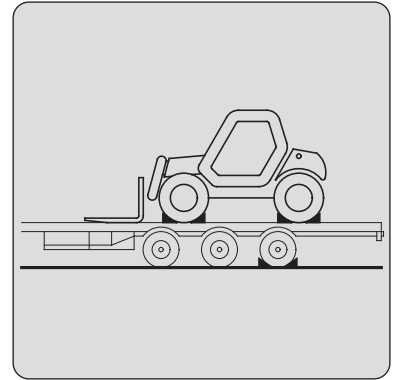

# ***4 - OPTIONAL ADAPTABLE ATTACHMENTS FOR THE RANGE***



## 4 - OPTIONAL ADAPTABLE ATTACHMENTS FOR THE RANGE

<b>INTRODUCTION</b>	<b>4-3</b>
<b>PICKING UP THE ATTACHMENTS</b> MT 420 H 57K ST5 S1	<b>4-4</b>
<b>PICKING UP THE ATTACHMENTS</b> MT 420 H TSS 57K ST5 S1	<b>4-6</b>
<b>TECHNICAL SPECIFICATIONS OF ATTACHMENTS</b> MT 420 H 57K ST5 S1	<b>4-8</b>
<b>TECHNICAL SPECIFICATIONS OF ATTACHMENTS</b> MT 420 H TSS 57K ST5 S1	<b>4-11</b>
<b>ATTACHMENT GUARDS</b>	<b>4-14</b>

### INTRODUCTION

- Your lift truck must be used with interchangeable equipment. These items are called: ATTACHMENTS.
- A wide range of attachments is available, guaranteed by MANITOU and designed to fit your lift truck perfectly.

#### **⚠ IMPORTANT ⚠**

*Only attachments approved by MANITOU can be used with their lift trucks (↪ 4 - ADAPTABLE ATTACHMENTS AS OPTIONS IN THE RANGE: TECHNICAL CHARACTERISTICS OF PLATFORMS).*

*The manufacturer cannot be held responsible for any modifications or adaptations to attachments without its knowledge.*

- The attachments are delivered with a load chart concerning your lift truck. The operator's manual and the load chart should be kept in the places provided in the lift truck. For standard attachments, their use is governed by the instructions contained on this notice.

#### **⚠ IMPORTANT ⚠**

*Maximum loads are defined by the capacity of a lift truck taking account of the attachment's mass and centre of gravity.*

*Should the attachment have a lower capacity than the lift truck, never exceed this limit.*

- Some particular uses require the adaptation of the attachment which is not provided in the price-listed options. Optional solutions exist, consult your dealer.

#### **⚠ IMPORTANT ⚠**

*Depending on their size, certain attachments may, when the boom is lowered and retracted, come into contact with the front tyres and cause damage to them if excavation is activated in the direction of the discharge.*

**TO PREVENT THIS RISK, EXTEND THE TELESCOPE TO A SUFFICIENT EXTENT FOR THE PARTICULAR LIFT TRUCK AND ATTACHMENT SO THAT THIS CONTACT IS NOT POSSIBLE.**

### SUSPENDED LOAD

#### **⚠ IMPORTANT ⚠**

*Suspended loads MUST be handled with a lift truck designed for that purpose (↪ 1 - OPERATING AND SAFETY INSTRUCTIONS: LOAD HANDLING INSTRUCTIONS: H - PICKING UP AND PUTTING DOWN A SUSPENDED LOAD).*

### 1 - ATTACHMENT WITHOUT HYDRAULICS AND HAND LOCKING DEVICE

#### FITTING AN ATTACHMENT

- Ensure that the attachment is in a position facilitating the locking to the carriage. If it is not correctly oriented, take the necessary precautions in order to move it safely.
- Check that the locking pin is in position in the bracket (Fig. A).
- Place the lift truck with the boom lowered in front of and parallel to the attachment, and tilt the carriage forwards (Fig. B).
- Bring the carriage under the locking tube of the attachment, slightly raise the boom, tilt the carriage backwards in order to position the attachment (Fig. C).
- Lift the attachment off the ground to facilitate locking.

#### MANUAL LOCKING

- Take the locking pin on the bracket (Fig. A) and lock the attachment (Fig. D). Do not forget to fit the cotter pin.

#### MANUAL UNLOCKING

- Proceed in the reverse order to MANUAL LOCKING, taking care to refit the locking pin in the bracket (Fig. A).

#### REMOVING THE ATTACHMENT

- Proceed in the reverse order to FITTING AN ATTACHMENT, taking care to store the attachment flat on the ground and in the closed position.

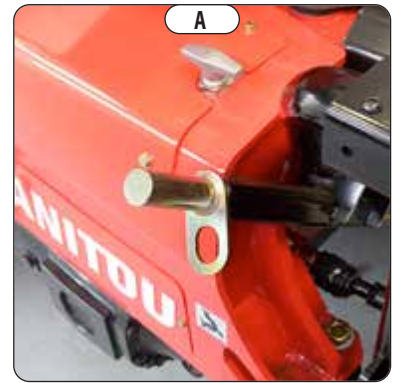

## 2 - HYDRAULIC ATTACHMENT AND MANUAL LOCKING DEVICE

### FITTING AN ATTACHMENT

- Ensure that the attachment is in a position facilitating the locking to the carriage. If it is not correctly oriented, take the necessary precautions in order to move it safely.
- Check that the locking pin is in position in the bracket (Fig. A).
- Place the lift truck with the boom lowered in front of and parallel to the attachment, and tilt the carriage forwards (Fig. B).
- Bring the carriage under the locking tube of the attachment, slightly raise the boom, tilt the carriage backwards in order to position the attachment (Fig. C).
- Lift the attachment off the ground to facilitate locking.

### MANUAL LOCKING AND CONNECTION OF THE ATTACHMENT

#### ⚠ IMPORTANT ⚠

*Make sure that the rapid connectors are clean and protect the holes which are not used, with the caps provided.*

- Take the locking pin on the bracket and lock the attachment (fig. D). Do not forget to fit the cotter pin.
- Stop the engine and keep the ignition on the lift truck.
- Release the pressure in the attachment hydraulic circuit by operating switch 1 on the distributor lever backwards and forwards 4 or 5 times.
- Connect the quick-release couplers according to the logic of the attachment's hydraulic movements.

### MANUAL RELEASE AND DISCONNECTION OF THE ATTACHMENT

- Proceed in the reverse order of paragraph MANUAL LOCKING AND CONNECTION OF THE ATTACHMENT, taking care to refit the locking pin in the bracket.

### REMOVING THE ATTACHMENT

- Proceed in the reverse order to FITTING AN ATTACHMENT, taking care to store the attachment flat on the ground and in the closed position.

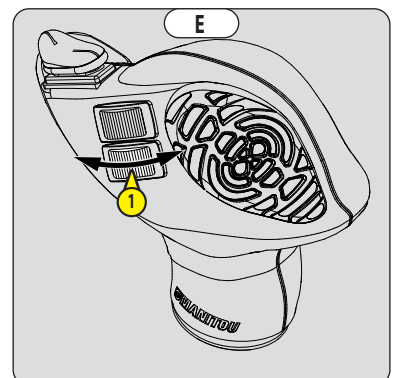
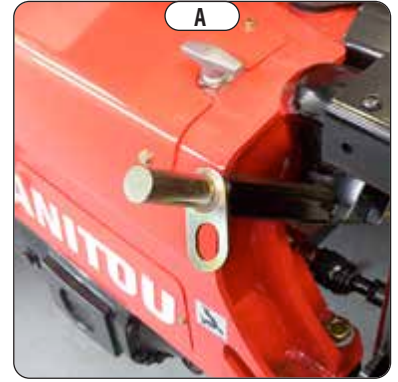

## 1 - ATTACHMENT WITHOUT HYDRAULICS AND HAND LOCKING DEVICE

### FITTING AN ATTACHMENT

- Ensure that the attachment is in a position facilitating the locking to the carriage. If it is not correctly oriented, take the necessary precautions in order to move it safely.
- Place the lift truck with the boom lowered, facing the attachment 1.
- Lift the levers 2 to position A (Fig. A).
- Tilt the carriage 3 forwards (Fig. A).
- Move the coupling points 4 of the carriage 3 under the coupling points 5 on the attachment (Fig. A).
- Lift the boom slightly and tilt the carriage backwards to position the attachment (Fig. B).
- Lift the attachment off the ground to facilitate locking.

### MANUAL LOCKING

- Lower the levers 2 to position B to lock the attachment (Fig. C).

### MANUAL UNLOCKING

- Proceed in the reverse order to MANUAL LOCKING .

### REMOVING THE ATTACHMENT

- Proceed in the reverse order to FITTING AN ATTACHMENT, taking care to store the attachment flat on the ground and in the closed position.

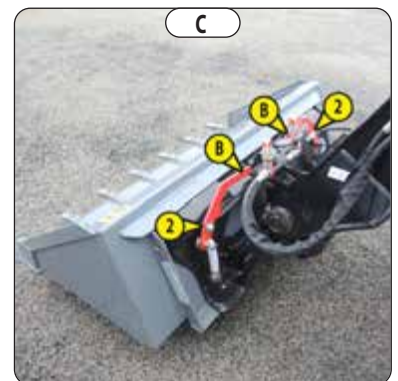
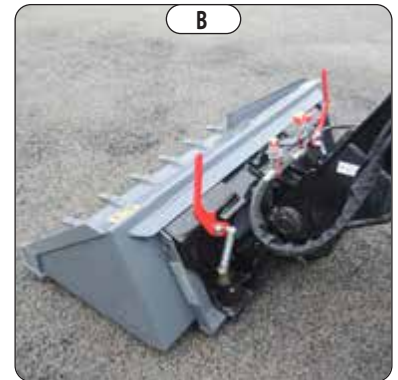
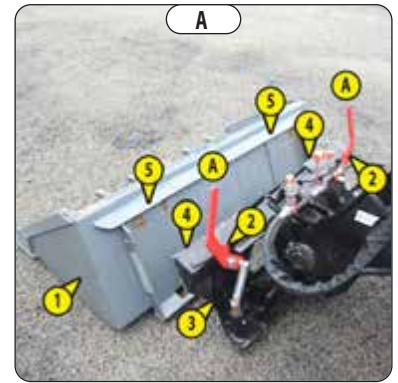



## TECHNICAL SPECIFICATIONS OF ATTACHMENTS MT 420 H 57K ST5 S1

### STANDARDISED TILTING FORK CARRIAGE

	<b>PART NO.</b>	<b>PFB 20 N 1020 S2</b>
		<b>52558727</b>
Rated capacity		2300 kg
Width		1020 mm
Weight		67 kg

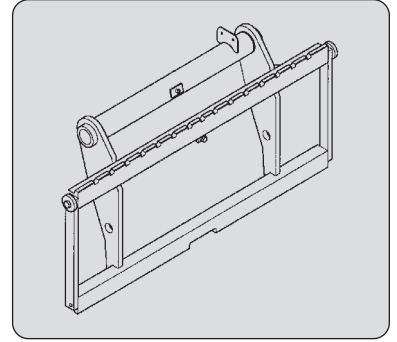

### STANDARDISED FORK

	<b>PART NO.</b>	<b>415691</b>
Section		100x40x1200 mm
Weight		44 kg

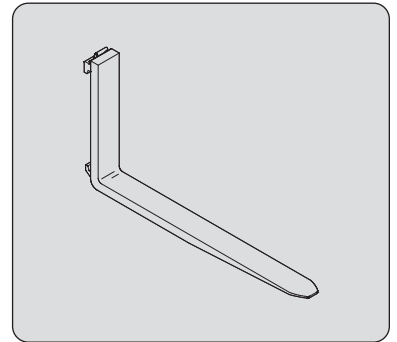

### STANDARDISED TILTING FORK CARRIAGE

	<b>PART NO.</b>	<b>PFB 25 N MT-1020 S2</b>
		<b>571958</b>
Rated capacity		2300 kg
Width		1020 mm
Weight		71 kg

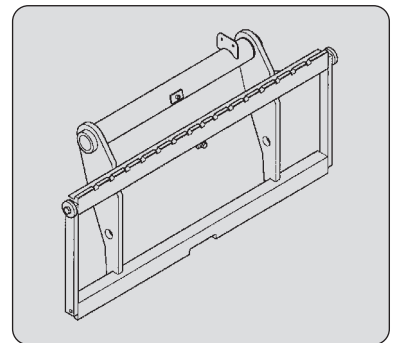

### STANDARDISED FORK

	<b>PART NO.</b>	<b>415835</b>
Section		125x40x1200 mm
Weight		76 kg

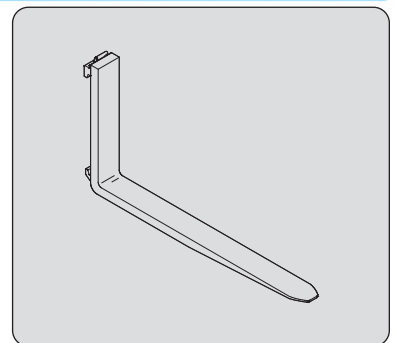

### LOAD BACK REST

	<b>PART NO.</b>	<b>555320</b>	<b>570518</b>
Width		1020 mm	1260 mm
Weight		31 kg	35 kg

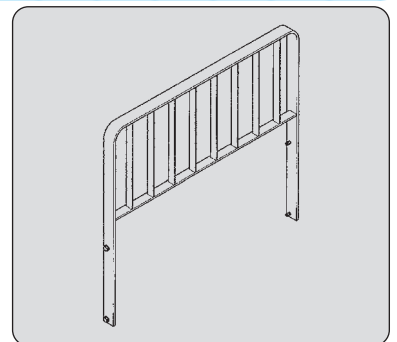

## FLOATING FORK CARRIAGE

	CAF 1000 / 3 LB	CAF 1000 / 3 LB (b)
<b>PART NO.</b>	<b>52654990</b>	<b>52744200</b>
Rated capacity	3000 kg	3000 kg
Width	1002 mm	1002 mm
Weight	240 kg	254 kg

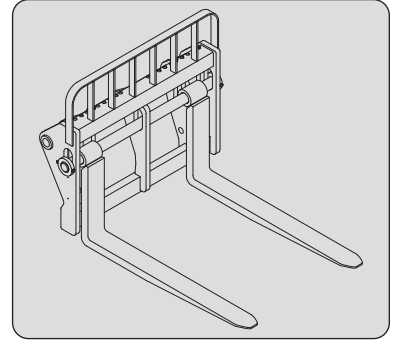

## FLOATING FORK

	<b>PART NO.</b>	<b>211919</b>
Section		120x40x1200 mm
Weight		60 kg

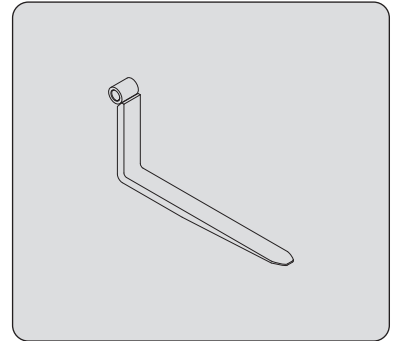

## BUILDING BUCKET

	<b>PART NO.</b>	<b>CBC 500 L1500</b>	<b>654474</b>
Rated capacity			519 ℓ
Width			1500 mm
Weight			280 kg

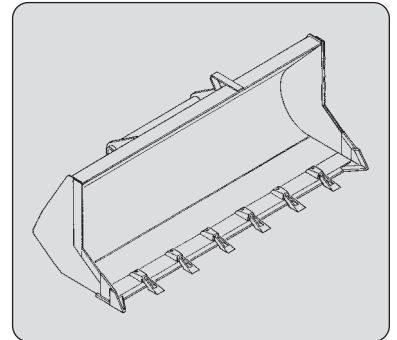

## LOADING BUCKET

	<b>PART NO.</b>	<b>CBR 600 L1500</b>	<b>570614</b>
Rated capacity			583 ℓ
Width			1500 mm
Weight			285 kg

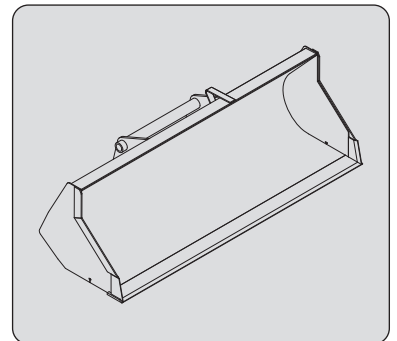

## MULTIPURPOSE BUCKET DISPLAY

	<b>PART NO.</b>	<b>CB4X1-400 L1500</b>	<b>52551750</b>
Rated capacity			700 ℓ
Width			1950 mm
Weight			640 kg

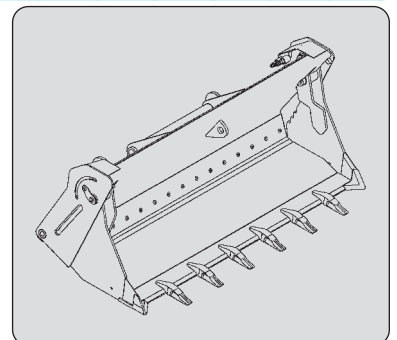

### CONCRETE BUCKET (ADAPTABLE ON FORKS)

<b>PART NO.</b>	<b>BB 500 S4</b> <b>654409</b>
Rated capacity	500 ℓ/1300 kg
Width	1100 mm
Weight	205 kg

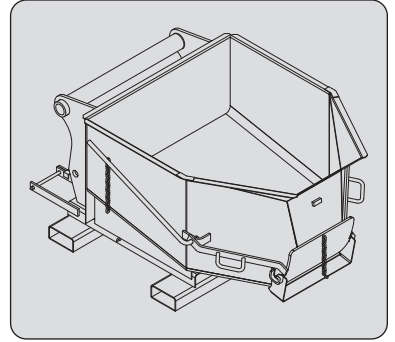

### CONCRETE BUCKET WITH SPOUT (ADAPTABLE ON FORKS)

<b>PART NO.</b>	<b>SCC 2050</b> <b>52000514</b>
Rated capacity	-
Width	2050 mm
Weight	630 kg

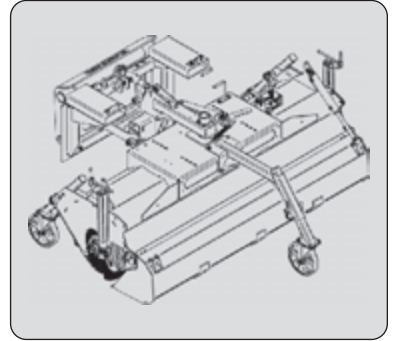

### SPOUT BUCKET (ADAPTABLE ON FORKS)

<b>PART NO.</b>	<b>SCC 2050+</b> <b>52000516</b>
Rated capacity	-
Width	2050 mm
Weight	640 kg

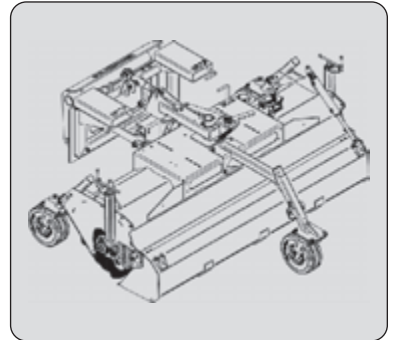

### SPOUT BUCKET (ADAPTABLE ON FORKS)

<b>PART NO.</b>	<b>SCC 2050 HWA+</b> <b>52000518</b>
Rated capacity	120 ℓ
Width	2050 mm
Weight	690 kg

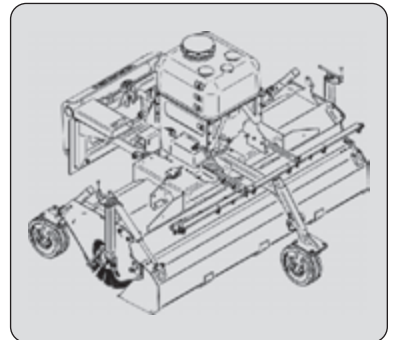

### JIB

<b>PART NO.</b>	<b>PC 50</b> <b>708544</b>
Rated capacity	5000 kg
Weight	120 kg

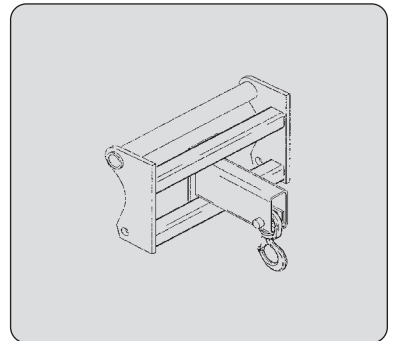

**FLOATING FORK CARRIAGE**

	<b>PART NO.</b>	<b>PFB "SLIM" SK</b>
Rated capacity	<b>52000825</b>	2500 kg
Width		1150 mm
Weight		78 kg

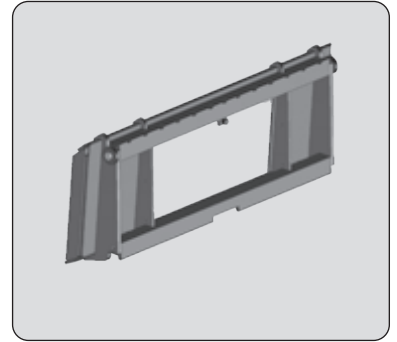

**STANDARDISED TILTING FORK CARRIAGE**

	<b>PART NO.</b>	<b>PFB 20 N MT-1020 SK</b>
Rated capacity	<b>52611332</b>	2300 kg
Width		1020 mm
Weight		71 kg



**STANDARDISED FORK**

	<b>PART NO.</b>	<b>415835</b>
Rated capacity		125x40x1200 mm
Weight		76 kg

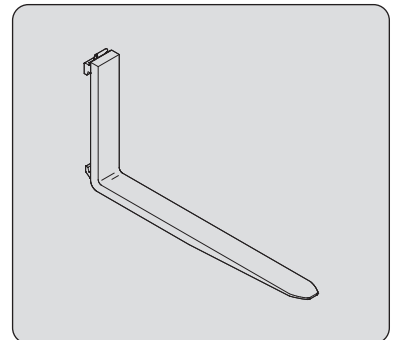

## BUILDING BUCKET

<b>PART NO.</b>	<b>CBC 500 L1500 SK</b>
	<b>52000784</b>
Rated capacity	519 ℓ
Width	1500 mm
Weight	262 kg

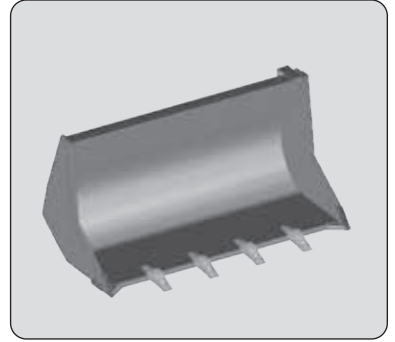

## LOADING BUCKET

<b>PART NO.</b>	<b>CBR 600 L1500 SK</b>
	<b>52000783</b>
Rated capacity	583 ℓ
Width	1500 mm
Weight	285 kg

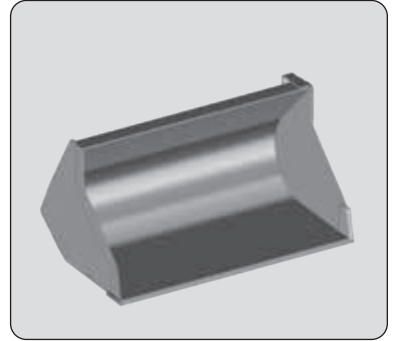

## MULTIPURPOSE BUCKET DISPLAY

<b>PART NO.</b>	<b>CB4X1-550 L1500 SK</b>
	<b>52000785</b>
Rated capacity	700 ℓ
Width	1950 mm
Weight	640 kg

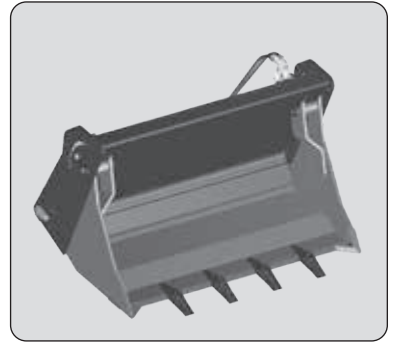

## POTS CLAMP

### CLP 1000 / 800 SK LB

<b>PART NO.</b>	<b>52611332</b>
Rated capacity	800 kg
Width	1200 mm

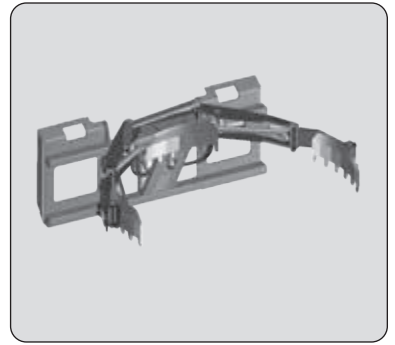

## BOOM CRANE WITH BIG BAG

### HBB 1500/2400 SK

<b>PART NO.</b>	<b>52578030</b>
Rated capacity	2400 kg
Weight	190 kg

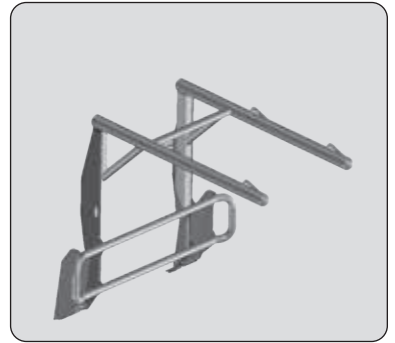

## JIB

### JH 2500

<b>PART NO.</b>	<b>52579090</b>
Rated capacity	2500 kg
Weight	110 kg

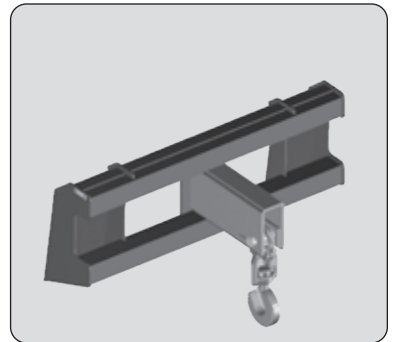

## ATTACHMENT GUARDS

### FORK GUARD

PART NO. 227801

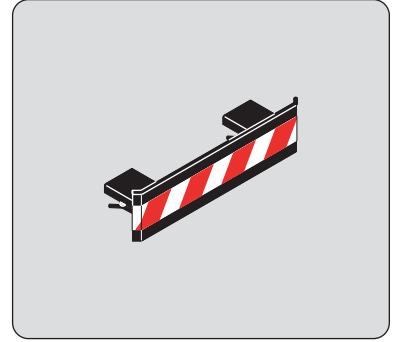

### FORK BLOCK FOR FLOATING FORK CARRIAGE

PART NO. 261210

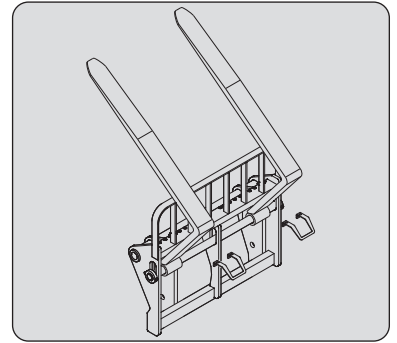

### BUCKET PROTECTOR

*Always ensure that the width of the protector you choose is less than or equal to the width of the bucket.*

Width	PART NO. 206734	206732	206730
	1375 mm	1500 mm	1650 mm
Width	PART NO. 235854	206728	206726
	1850 mm	1950 mm	2000 mm
Width	PART NO. 223771	223773	206724
	2050 mm	2100 mm	2150 mm
Width	PART NO. 206099	206722	223775
	2250 mm	2450 mm	2500 mm

