



52738292 EN-USM4 (C-07/2024)

ULM 412 H 36Y ST5 S1
ULM 415 H 36Y ST5 S1

OPERATOR'S MANUAL
(ORIGINAL MANUAL)

IMPORTANT

Carefully read and understand this instruction manual before using this machine.

It contains all information relating to operation, handling and equipment, as well as important recommendations to be followed.

This document also contains precautions for use, as well as information on the service and routine maintenance required to ensure the machine's continued reliability and safety of use.

WHENEVER YOU SEE THIS SYMBOL, IT MEANS:



PLEASE NOTE! BE CAREFUL! YOUR SAFETY, THAT OF OTHERS, OR THE SAFETY OF THE MACHINE IS AT RISK.

- This manual has been produced based on the equipment list and technical characteristics given at the time of its design.
- The machine's equipment level depends on the options chosen and the country of sale.
- Depending on the machine's options and the date of sale, certain equipment or functions described in this manual may not be present on this machine.
- Descriptions and figures are non-binding.
- MANITOU reserves the right to change its models and their equipment without being required to update this manual.
- The MANITOU network, consisting exclusively of qualified professionals, is available to answer all your questions.
- This manual is an integral part of the machine.
- It is to be kept in its storage location at all times for ease of reference.
- Give this manual to the new owner if the machine is resold.

1st EDITION

A-05/2022

UPDATED

B-11/2022

UNPUBLISHED

C-07/2024

**2-6 – 2-9 ; 2-15 ; 2-18 ; 2-19
2-27 ; 2-28 ; 2-38 ; 2-39 ; 2-58 ; 2-62 ; 2-75
3-10 ; 3-25 ; 3-32 ; 3-40 ; 3-42 ; 3-43**

The brochure and all its contents, including diagrams, are the proprietary and confidential intellectual property of Manitou BF and / or its subsidiaries ("Manitou Group"). Any reproduction, publication or dissemination of any part of the brochure without the express written authorization of Manitou Group is strictly prohibited. Any violation of this provision will subject the offending party to prosecution by Manitou Group to the fullest extent of the law. The logos and the company's visual identity are the property of Manitou Group and may not be used without the express written authorization of Manitou Group.

All trademarks, registered and unregistered, is and shall remain the property of Manitou BF or its respective owner.

Any reproduction, source code access, decompilation, modification, copy (other than backup copies), correction of errors, transmission or distribution of any software built into Manitou Group machines is strictly prohibited.

In the event that the measures above nevertheless prove essential to enable use of the software, in accordance with its destination, or to obtain the information required for interoperability with other software created independently, the user should contact Manitou Group in advance and Manitou may, at its sole discretion, take the necessary measures or give access to only the information strictly necessary for interoperability.

Any breach of these requirements is likely to constitute a counterfeiting offense subject to legal action by Manitou Group.

Connected Manitou Group machines are equipped with boxes that collect technical data on the machines (such as geo-tracking data or data on component operation). This data, which is organized, processed and enhanced by algorithms and expertise proprietary to Manitou Group, constitutes, in combination with other elements, independent or not, a protected database according to laws & regulations on IP purposes.

It is strictly forbidden to have access to all or part of this database and to use the data (including in the event of accidental access) without explicit prior authorization from Manitou Group. In the event that Manitou Group authorizes a Manitou Group machine user to access all or part of this database, Manitou Group, as producer of this database, cedes to the user only a right to personal, non-exclusive, non transferable use of the database, and only by access to an information technology platform hosted by a server owned or controlled by Manitou Group.

In any case, the following are strictly prohibited:

- any extraction, reproduction, representation, reuse through provision to the public, distribution, transfer, permanent or temporary, on any medium, by any means, and in any form whatsoever, of all or of a qualitatively or quantitatively substantial part of the contents of this database,*
- any extraction, reproduction, representation, reuse through provision to the public, distribution, transfer, repeated or systematic of qualitatively or quantitatively insubstantial parts of the content of the database during operations manifestly exceeding normal use of the database by the user of the machine for his own needs,*
- any use of means to bypass technical protection measures for databases or software source code embedded in the boxes, in keeping according to laws & regulations on IP purposes.*

The latest updated version in force and binding of this document is the version available on demand.

Only the electronic version is maintained.

MANITOU BF S.A. Public limited company with a board of directors.

Head office: 430 rue de l'Aubinière - 44150 Ancenis - France

Share capital: €39,548,949

Entered in the Nantes Trade and Companies Register under number 857 802 508.

Tel.: +33 (0) 2 40 09 10 11

www.manitou.com

1 - OPERATING AND SAFETY INSTRUCTIONS

2 - DESCRIPTION

3 - MAINTENANCE

4 - ATTACHMENTS

1 - OPERATING AND SAFETY INSTRUCTIONS

1 - OPERATING AND SAFETY INSTRUCTIONS

INSTRUCTIONS TO THE COMPANY MANAGER

1-4

THE SITE	1-4
THE OPERATOR	1-4
THE MACHINE	1-4
A - SUITABILITY OF THE MACHINE FOR THE TASK	1-4
B - ADAPTING THE MACHINE TO USUAL ENVIRONMENTAL CONDITIONS	1-4
C - MODIFYING THE MACHINE	1-5
D - FRENCH ROAD TRAFFIC RULES	1-5
E - MACHINE CAB PROTECTION	1-5
INSTRUCTIONS	1-6
MAINTENANCE	1-6

INSTRUCTIONS FOR THE OPERATOR

1-8

FOREWORD	1-8
GENERAL INSTRUCTIONS	1-8
A - OPERATOR'S MANUAL	1-8
B - AUTHORIZATION FOR USE IN FRANCE	1-8
C - MAINTENANCE	1-8
D - TIRES	1-9
E - MODIFYING THE MACHINE	1-9
F - LIFTING PEOPLE	1-9
OPERATING INSTRUCTIONS UNLADEN AND LADEN	1-10
A - BEFORE STARTING UP THE MACHINE	1-10
B - AVAILABLE IN THE DRIVER'S CAB	1-10
C - ENVIRONMENT	1-10
D - VISIBILITY	1-11
E - STARTING THE MACHINE	1-12
F - OPERATING THE MACHINE	1-12
G - STOPPING THE MACHINE	1-14
H - DRIVING THE MACHINE ON THE PUBLIC HIGHWAY	1-15
INSTRUCTIONS FOR HANDLING A LOAD	1-18
A - CHOICE OF ATTACHMENTS	1-18
B - WEIGHT OF LOAD AND CENTER OF GRAVITY	1-18
C - LONGITUDINAL STABILITY LIMITER AND WARNING DEVICE	1-18
D - TRANSVERSE ATTITUDE OF THE MACHINE	1-19
E - PICKING UP A LOAD ON THE GROUND	1-19
F - PICKING UP AND PUTTING DOWN A HIGH LOAD ON TIRES	1-20
G - PICKING UP AND PUTTING DOWN A HIGH LOAD ON STABILIZERS	1-22
H - PICKING UP AND PUTTING DOWN A SUSPENDED LOAD	1-24
I - TRAVELING WITH A SUSPENDED LOAD	1-24
INSTRUCTIONS FOR USE AS A LOADER	1-25
A - LOADING	1-25
B - BACKFILLING	1-25
INSTRUCTIONS FOR USING THE MOBILE ELEVATING WORK PLATFORM	1-26
A - AUTHORIZATION FOR USE	1-26
B - SUITABILITY OF THE PLATFORM FOR THE JOB	1-26
C - PROVIDED ON THE PLATFORM	1-26
D - USING THE PLATFORM	1-27
E - ENVIRONMENT	1-28
F - MAINTENANCE	1-28
INSTRUCTIONS FOR USING THE RADIO-CONTROL	1-29
HOW TO USE THE RADIO-CONTROL	1-29
PROTECTIVE DEVICES	1-29

MACHINE MAINTENANCE INSTRUCTIONS

1-30

GENERAL INSTRUCTIONS	1-30
PLACING THE JIB SAFETY WEDGE	1-30
FITTING THE WEDGE	1-30
REMOVING THE WEDGE	1-30
FITTING THE WEDGE	1-30
REMOVING THE WEDGE	1-30
MAINTENANCE	1-31
MAINTENANCE LOGBOOK	1-31
LUBRICANT AND FUEL LEVELS	1-31
HYDRAULICS	1-31
ELECTRICITY	1-31
WELDING ON THE MACHINE	1-31
WASHING THE MACHINE	1-32
TRANSPORTING THE MACHINE	1-32

PROLONGED MACHINE SHUTDOWN

1-32

INTRODUCTION	1-32
PREPARATION OF THE MACHINE	1-32
DEF (Diesel Exhaust Fluid) TANK	1-32
PROTECTING THE ENGINE	1-33
MACHINE PROTECTION	1-33
RETURNING THE MACHINE TO SERVICE	1-33

DISPOSING OF THE MACHINE

1-34

RECYCLING OF MATERIALS	1-34
METALS	1-34
PLASTICS	1-34
RUBBER	1-34
GLASS	1-34
ENVIRONMENTAL PROTECTION	1-34
WORN OR DAMAGED PARTS	1-34
USED OIL	1-34
USED BATTERIES.	1-34

INSTRUCTIONS TO THE COMPANY MANAGER

THE SITE

Proper management of the machine's area of travel will reduce the risk of accidents:

- ground not unnecessarily uneven or obstructed,
- no excessive slopes,
- pedestrian traffic controlled, etc.

THE OPERATOR

- Only qualified, authorized personnel can use the machine. This authorization is given in writing by the appropriate person in the establishment where the machine is to be used and must be carried permanently by the operator.

⚠ IMPORTANT ⚠

Experience has shown that there are a number of inappropriate ways in which the machine might be operated. Such foreseeable misuse, of which the main examples are listed below, are strictly forbidden.

- The foreseeable abnormal behavior resulting from ordinary negligence, but not from any intentional misuse of the equipment.

- The reflex reactions of a person in the event of a malfunction, incident, fault, etc. during operation of the machine.

- Behavior resulting from application of the "principle of least effort" when performing a task.

- For certain machines, the foreseeable behavior of such persons as: apprentices, teenagers, handicapped persons, trainees tempted to drive a machine, operators tempted to operate a machine to win a bet, in competition or for their own personal experience.

The person in charge of the equipment must take these criteria into account when assessing whether or not a person will make a suitable driver.

THE MACHINE

A - SUITABILITY OF THE MACHINE FOR THE TASK

- MANITOU has ensured that this machine is suitable for use under the standard operating conditions defined in this operator's manual, with a **STATIC TEST COEFFICIENT OF 1.25** and a **DYNAMIC TEST COEFFICIENT OF 1**, as specified in harmonized standard **EN 1459** for variable reach machines.
- Before commissioning, the facility manager must make sure that the machine is appropriate for the work to be done, and perform certain tests (in accordance with applicable legislation).

B - ADAPTING THE MACHINE TO USUAL ENVIRONMENTAL CONDITIONS

⚠ IMPORTANT ⚠

For operation under average climatic conditions, i.e. between -15 °C and +35 °C, correct levels of lubricants in all the circuits are checked in production. -15 °C to +35 °C

For operation under more severe climatic conditions, before starting up, drain all circuits then fill using lubricants suitable for the ambient temperatures.

The same applies to the coolant.

⚠ IMPORTANT ⚠

The machines are designed for outdoor use under normal atmospheric conditions and indoor use in suitably aerated and ventilated premises. It is prohibited to operate the machine in areas which presents a risk of fire or which are potentially explosive (e.g. refineries, fuel or gas depots, stores of flammable products, etc.).

Specialized equipment is available when operating in these areas (ask your dealer for information).

- Our machines are designed to be used within a temperature range of -18 °C to +43 °C.
- In addition to the standard equipment fitted on your machine, many options are available, such as: road lighting, stop lights, rotating beacon light, reverse lights, front worklight, rear worklight, lifting structure worklight, etc. (depending on machine model).
- The operator must take into account the operating conditions to specify the machine's signaling and lighting equipment. Consult your dealer.
- Take into account the climatic and atmospheric conditions of the operation site. Consult your dealer for the suitability of lubricants and frost protection.
- Take into account the fire risk associated with use in dusty and flammable conditions (e.g. straw, flour, sawdust, organic waste, etc.).
- A machine operating in an area without fire extinguishing equipment must be equipped with an individual extinguisher. Solutions exist, consult your dealer.

Our machines comply with Directive 2014/30/EU (2015/208/EU for our type-approved "TRACTOR" machines) concerning electromagnetic compatibility (EMC), (UK : Electromagnetic Compatibility Regulations 2016) and with the corresponding harmonized standard EN 12895. Their correct operation is no longer guaranteed if they are used within areas in which the electromagnetic fields exceed the limit specified by this standard (20 V/m).

- Directive 2002/44/EC requires company managers to not expose their employees to excessive vibration doses. There is no recognized code of measurement for comparing the machines of different manufacturers. The actual doses received cannot therefore be measured under actual operating conditions at the user's premises.
- The following are some tips for minimizing these vibration doses:
 - Select the most suitable machine and attachment for the intended use.
 - Adapt the seat adjustment to the operator's weight (**depending on machine model**) and maintain it in good condition, as well as the cab suspensions. Inflate the tires in accordance with recommendations.
 - The seat is an essential way of reducing the vibrations transmitted to the operator. In the event of seat replacement, please contact MANITOU.
 - Ensure that the operators adapt their operating speed to suit the conditions on site.
 - As far as possible, arrange the site in such a way as to provide a flat running surface and remove obstacles and harmful potholes.

C - MODIFYING THE MACHINE



Modifying the structure and settings of the various components of your machine (hydraulic pressure, taring of limiters, engine speed, sensors, addition of extra equipment, addition of counterweights, unapproved and unauthorized attachments, alarm systems, etc.) yourself is strictly prohibited. In this case, the manufacturer cannot be held responsible.

D - FRENCH ROAD TRAFFIC RULES

(or see current legislation in other countries)

- Only one EC declaration of conformity is issued. It must be kept in a safe place.
- The road traffic rules for the machines are subject to the provisions of the highway code, according to the following categories:
 - Construction machinery (MT range): public works vehicle not predominantly for use on roads (point 6.9 of Article R.311-1 of the French Highway Code). The machine must have a 25 disc displayed on the rear of the machine and an operating license plate.
 - Non-type-approved "Tractor" machinery for agricultural work: (point 6.2 of Article R.311-1 of the French Highway Code). The machine must be fitted with an operating license plate.
 - Type-approved "Tractor" machinery for agricultural work: Agricultural tractor type T1a (point 5.1.1 of Article R.311-1 of the French Highway Code). The machine must be licensed.

SPECIAL INSTRUCTIONS APPLICABLE TO TYPE-APPROVED "TRACTOR" MACHINES

- All approved machines are supplied with a "Tractor" certificate of compliance with Regulation 167/2013, to be retained by the owner, and a page of administrative details together with a CNIT number (national type approval code) for registration at the prefecture.
- The owner of the machine is responsible for carrying out the necessary procedures for obtaining the vehicle registration document within the time limit defined by the regulations.
- The operator must hold a category B driver's license, unless granted an exemption.
- The machine must be driven on the public highway in accordance with the instructions given in the manual supplied with the machine (Gross weight, Gross combination weight, towing load, axle loads, maximum speeds, etc. according to the type/version). The operator must be in possession of the machine's registration document.



**When towing a trailer or agricultural equipment, the traveling speed of the machine is limited to 25 km/h.
In this case, a "25" disc must be affixed to the rear of the convoy.**

E - MACHINE CAB PROTECTION

- All machines comply with standard ISO 3471 Roll-over Protective Structures (ROPS)
- All machines comply with standard ISO 3449 Falling-Object Protective Structures (FOPS) (Level I or II) (↖ 2 - DESCRIPTION OF STICKERS AND PLATES)
- The windows used on our machines comply with standard ECE-R43 Operator Protective Structures (OPS).
- Approved "TRACTOR" machines also comply with the regulations:
 - (appendix 1322/2014-OCDE Code 4).
 - (appendix 1322/2014-OCDE Code 10).



**Structural damage or overturning, a modification, changes or a poorly executed repair can reduce the protective efficiency of the cab, canceling its compliance.
Do not perform welding or drilling on the cab structure.
Consult your dealer to determine the limits of this structure without canceling its compliance.**

INSTRUCTIONS

- The operator's manual must always be in good condition, in the language of the operator and placed in the storage compartment provided.
- The operator's manual and any plates or stickers which are no longer legible or are damaged, must be replaced immediately.

MAINTENANCE

⚠ IMPORTANT ⚠

Refer to chapter: MACHINE MAINTENANCE INSTRUCTIONS.

⚠ IMPORTANT ⚠

Your machine must be periodically inspected to ensure its continued compliance.

The frequency of this inspection is defined by the legislation in force in the country in which the machine is used.

- Maintenance or repairs other than those detailed in Part: 3 - MAINTENANCE must be carried out by qualified personnel (consult your dealer) and in the necessary safety conditions to preserve the health of the operator and any third party.
- Example for France "The manager in charge of the establishment using a machine must open and maintain a maintenance log for each machine (order of March 2, 2004) and undergo a general periodic inspection every 6 months (order of March 1, 2004)".

INSTRUCTIONS FOR THE OPERATOR

FOREWORD

⚠ IMPORTANT ⚠

The risk of accident while using, servicing or repairing this machine can be reduced if you follow the safety instructions and preventive measures detailed in this instruction manual.

Failure to respect the safety and operating instructions, or the instructions for repairing or servicing your machine may lead to serious, even fatal accidents.

⚠ IMPORTANT ⚠

In order to reduce or prevent any danger with a MANITOU-approved attachment, follow the instructions in paragraph: 4 - ADAPTABLE ATTACHMENTS AVAILABLE ON THE RANGE: INTRODUCTION.

- Only the operations and maneuvers described in these operator's manual must be performed. The manufacturer cannot predict all possible risky situations. Consequently, the safety instructions given in the operator's manual and on the machine itself are not exhaustive.
- At all times, as an operator, you must envisage, within reason, the possible risk to yourself, to others or to the machine when you use it.
- The operator is responsible for the machine in all circumstances, regardless of whether he is present in the driver's cab.

GENERAL INSTRUCTIONS

A – OPERATOR'S MANUAL

⚠ IMPORTANT ⚠

Carefully read and understand this operator's manual before operating this machine.

- The operator's manual must always be in good condition, in the language of the operator and placed in the storage compartment provided.
- Any operations or maneuvers not described in the operator's manual are proscribed.
- Follow the safety advice and the instructions described on the machine's stickers.
- Familiarize yourself with the machine on the ground where it will be operated.
- You must replace the instruction manual, as well as any plates or stickers, if they are no longer legible or are missing or damaged.

B - AUTHORIZATION FOR USE IN FRANCE

(or see current legislation in other countries).

- Only qualified, authorized personnel can use the machine. This authorization is given in writing by the appropriate person in the establishment where the machine is to be used and must be carried permanently by the operator.
- The operator is not empowered to authorize the driving of the machine by another person.

C - MAINTENANCE

- If the operator sees that the machine is not in good working order or does not comply with the safety instructions, he must inform his manager of this immediately.
- The operator is prohibited from carrying out any repairs or adjustments himself, unless he has been trained for this purpose. He must keep the machine properly cleaned if this is his responsibility.
- The operator must carry out the daily maintenance (↖ 3 - MAINTENANCE) before using the machine in his place of work.
- The operator is responsible for deciding and adjusting the frequency and type of the cleaning needed to prevent the risk of fire ensuing from the build-up of flammable material(s). The operator should pay special attention to all the areas of the machine where these high-risk materials are likely to accumulate (e.g. engine compartment, under the lifting structure, above the axles, inside the chassis, etc.).

D - TIRES

⚠ IMPORTANT ⚠

Do not use the machine if the wheels are damaged or excessively worn, because this could put your own safety or that of others at risk, or cause damage to the machine.

- The operator must ensure tires are suitable for the nature of the ground (see contact surface with the ground for the tires in the chapter: 2 - DESCRIPTION: TIRES). Optional solutions are available, please consult your dealer.
 - SAND tires.
 - FARM tires.
 - Snow chains.
- The machine's four tires must be the same brand, the same dimensions, the same structure (radial or diagonal) and the same usage category (normal, snow or special), and must have the same degree of tread wear.
- In the event of tire replacement, use tires authorized by MANITOU that are the same type and dimensions. Using different tires voids the machine's type approval and you may be liable.
- If you are replacing just one of the machine's tires (e.g. because it is damaged), we recommend choosing a tire with the same degree of wear as the remaining tires so as not to damage the transmission's kinematic chain.

⚠ IMPORTANT ⚠

*Do not use the machine if the tires are damaged or excessively worn, because this could put your own safety or that of others at risk, or cause damage to the machine itself.
The fitting of foam inflated tires is prohibited and is not guaranteed by the manufacturer unless with prior authorization.*

E - MODIFYING THE MACHINE

- ⚠ INSTRUCTIONS TO THE COMPANY MANAGER: ⚠ C - MODIFYING THE MACHINE.

F - LIFTING PEOPLE

- The use of working equipment and load lifting attachments to lift people is:
 - either forbidden
 - or authorized exceptionally and under certain conditions (⚠ regulations in force in the country in which the machine is used).
- The pictogram posted at the operator station reminds you that:
 - Left-hand column
 - It is forbidden to lift people, with any kind of attachment, using a non PLATFORM-fitted machine.
 - Right-hand column
 - With a PLATFORM-fitted machine, people can only be lifted using platforms designed by MANITOU for this purpose.
- MANITOU sells equipment specifically designed for lifting people (OPTION PLATFORM-fitted machine; contact your dealer).

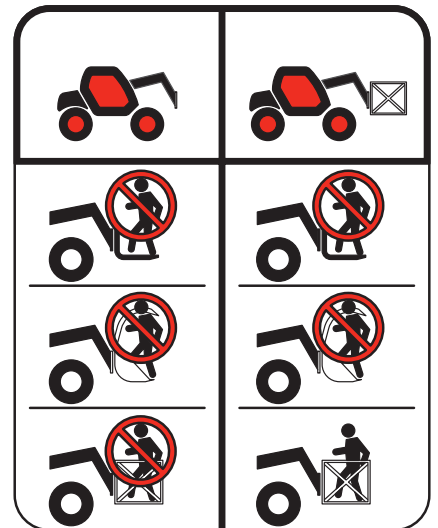

A - BEFORE STARTING UP THE MACHINE

- Perform the daily maintenance operations (< 3 - MAINTENANCE).
- Make sure that the driver's cab is clean, particularly the floor and floor mat. Check that no movable object may hinder the operation of the machine.
- Make sure the lights, turn signals and windshield wipers are working properly.
- Make sure the rear-view mirrors are in good condition, clean and properly adjusted.
- Make sure the horn works.

B - AVAILABLE IN THE DRIVER'S CAB

- Whatever his experience, the operator is advised to familiarize himself with the position and operation of all the controls and instruments before operating the machine.
- Wear clothes suitable for driving the machine, avoid loose clothing.
- Make sure you have the appropriate protective equipment for the task to be performed.
- Prolonged exposure to high noise levels may cause hearing problems. It is recommended to wear ear muffs to protect against excessive noise.
- Always face the driver's cab access when getting in and out of the lift truck and use the handle(s) provided for this purpose. Do not jump out of the machine.
- Remain alert at all times when using the machine. Do not listen to the radio or music using headphones or earphones.
- Never operate the lift truck when hands or feet are wet or soiled with greasy substances.
- For increased comfort, adjust the seat to your requirements and adopt the correct position in the driver's cab.



Under no circumstances must the seat be adjusted while the machine is moving.

- The operator must always be in his normal position in the driver's cab: Arms and legs, and generally any part of the body, should be kept inside the driver's cab of the machine.
- The safety belt must be worn and adjusted to the operator's size.
- The control units must never be used for any other than their intended purposes (e.g. Climbing onto or down from the machine, coat hanger, etc.).
- If the control components are fitted with a forced operation (lever lock) device, it is forbidden to leave the cab without first putting these controls in neutral.
- It is prohibited to carry passengers either on the machine or in the cab.

C - ENVIRONMENT

- Comply with site safety regulations.
- If you have to use the machine in a dark area or work at night, make sure it is equipped with work lights.
- During handling operations, make sure that no one is in the way of the machine and its load.
- Do not allow anybody to come near the working area of the machine or pass beneath an elevated load.
- The maximum slope on which the machine can be used in relation to the capacity of the brake is 20%.
- When using the lift truck on a transverse slope, before lifting the lifting structures, observe the instructions given in the paragraph: INSTRUCTIONS FOR HANDLING A LOAD: D - TRANSVERSE ATTITUDE OF THE MACHINE.
- Traveling on a longitudinal slope:
 - Drive and brake gently.

- Moving without load: Forks or attachment facing downhill.

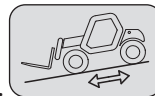

- Moving with load: Forks or attachment facing uphill.

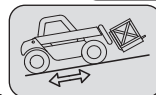

- Take into account the machine's dimensions and its load before trying to negotiate a narrow or low passageway.
- Never move onto a load bridge without having first checked:
 - That it is suitably positioned and made fast.
 - That the unit to which it is connected (wagon, truck, etc.) will not shift.
 - That this bridge is prescribed for the total weight of the machine, laden or unladen.
 - That this bridge is prescribed for the size of the machine.

- Never move onto a foot bridge, floor or freight lift, without being certain that they are suitable for the weight and size of the machine, laden or otherwise, and without having checked that they are in sound working order.
- Be careful in the area of loading bays, trenches, scaffolding, soft ground and manholes.
- Make sure the ground is stable and firm under the wheels and/or stabilizers before lifting or removing the load. If necessary, add appropriate wedging under the stabilizers.
- Make sure that the scaffolding, loading platform, pilings or ground is capable of bearing the load.
- Never stack loads on uneven ground, they may tip over.

⚠ IMPORTANT ⚠

If the load or the attachment must remain above a structure for a prolonged period of time, there is the risk that it will bear on the structure as the lifting structure descends due to cooling of the oil in the cylinders.

To eliminate this risk:

- *Regularly check the distance between the load or the attachment and the structure and readjust this if necessary.*
- *If possible use the machine at an oil temperature as close as possible to ambient temperature.*

- In the case of work near to overhead lines, ensure that the safety distance is sufficient between the machine's working area and the overhead line.

⚠ IMPORTANT ⚠

Do not operate this machine during thunderstorms, snowstorms, periods of frost, or in hazardous weather conditions.

⚠ IMPORTANT ⚠

You must consult your local electrical supplier.

You could be electrocuted or seriously injured if you operate or park the machine too close to power lines.

In the event of high winds, do not carry out handling work that jeopardizes the stability of the machine and its load, particularly if the load catches the wind badly.

- Prevent the fire risk associated with use in dusty and flammable conditions (e.g. straw, flour, sawdust, organic waste, etc.).

D - VISIBILITY

- The safety of people within the machine's working area, as well as that of the machine itself and the operator, are dependent on good operator visibility of the machine's immediate surroundings in all situations and at all times.
- This machine has been designed to allow good operator visibility (direct or indirect by means of rear-view mirrors) of the immediate surroundings of the machine while driving with no load and with the boom in the transport position.
- Special precautions must be taken if the size of the load restricts visibility towards the front:
 - moving in reverse,
 - site layout,
 - assisted by a person directing the operation (while standing outside the machine's area of travel), making sure to keep this person clearly in view at all times,
 - in any case, avoid reversing over long distances.
- Certain special accessories may require the machine to travel with the boom in the raised position. In such cases, visibility on the right hand side is restricted, and special precautions must be taken:
 - site layout,
 - assisted by a person directing the operation (while standing outside the machine's area of travel).
 - replacement of a suspended load by a load on a pallet.
- If visibility of your road is inadequate, ask someone to assist by directing the operation (while standing outside the machine's area of travel), making sure to keep this person clearly in view at all times.
- Keep all components affecting visibility in a clean, properly adjusted state and in good working order (e.g. windshields, windows, windshield wipers, windshield washers, driving lights and worklights, rear-view mirrors).

E - STARTING THE MACHINE

SAFETY INSTRUCTIONS

⚠ IMPORTANT ⚠

The machine must only be started up or maneuvered when the operator is sitting in the driver's cab with seat belt fastened and adjusted.

- Never try to start the machine by pushing or towing it. Such an operation may cause severe damage to the transmission. If necessary, towing requires the transmission to be put in neutral (↩ 3 - MAINTENANCE).
- If using an emergency battery for start-up, use a battery with the same characteristics and respect battery polarity when connecting it. Connect at first the positive terminals before the negative terminals.

⚠ IMPORTANT ⚠

*Failure to respect polarity between batteries can cause serious damage to the electrical circuit.
The electrolyte in the battery may produce an explosive gas. Avoid flames and generation of sparks close to the batteries.
Never disconnect a battery while it is in charge.*

INSTRUCTIONS

- Check the closing and locking of the hood(s).
- Check that the cab door is closed.
- Firmly press and hold down the brake pedal.
- Turn the ignition key to position (I) to switch on the machine and the engine preheat system.
- Check that the forward/reverse selector is in neutral, and that the manual parking brake is on.
- Check the fuel level on the dashboard gauge.
- Check the DEF (diesel exhaust fluid) level on the dashboard gauge. (depending on machine model)
- Turn the ignition key to position (III) for no longer than 15 seconds. The engine should then start. Release the ignition key and let the engine run at idling speed.
- Preheat the engine between each start attempt.
- Make sure all the signal lights on the control instrument panel are off.
- Check the longitudinal stability limiter and warning device (↩ 3 - MAINTENANCE).
- Do not use a machine that is non-compliant.
- Check all control instruments when the engine is warm and at regular intervals during use, so as to quickly detect any faults and to be able to correct them without any delay.
- If an instrument does not show the correct display, stop the engine and immediately carry out the necessary operations.

F - OPERATING THE MACHINE

SAFETY INSTRUCTIONS

⚠ IMPORTANT ⚠

We would like to draw the operators' attention to the risks involved in using the machine, in particular:

- Risk of losing control.

- Risk of loss of lateral and frontal stability of the machine.

The operator must remain in control of the machine.

In the event of the machine overturning, do not try to leave the cab during the incident.

YOUR BEST PROTECTION IS TO STAY FASTENED IN THE CAB.

- Observe the company's traffic regulations or, by default, the public highway code.
- Do not carry out operations which exceed the capacities of your machine or attachment.
- Always drive the machine with the forks or attachment in the transport position, i.e., 300 mm from the ground, the boom retracted and the forks carriage sloping backwards.
- Only carry loads which are balanced and properly anchored to avoid any risk of a load falling off.
- Ensure that pallets, cases, etc. are in good order and suitable for the load to be lifted.
- Familiarize yourself with the machine on the terrain where it will be used.
- Ensure that the brakes are working properly.
- The loaded machine must not travel at speeds in excess of 12 km/h.
- Drive smoothly at an appropriate speed for the operating conditions (land configuration, load on the machine).
- Do not use the hydraulic boom controls when the machine is moving.
- Never change the steering mode whilst driving.
- Ensure that visibility is adequate.
- Do not maneuver the machine with the boom in the raised position unless under exceptional circumstances and then with extreme caution, at very low speed and using gentle braking.
- Take bends slowly.

- In all circumstances make sure you are in control of your speed.
- On damp, slippery or uneven terrain, drive slowly.
- Brake gently, never abruptly.
- Only use the machine's forward/reverse selector from a stationary position and never do so abruptly.
- Do not drive with your foot on the brake pedal.
- Always remember that hydrostatic type steering is extremely sensitive to movement of the steering wheel, so turn it gently and not jerkily.
- Never leave the engine on when the lift truck is unattended.
- Do not leave the cab when the machine has a raised load.
- Look where you are going and always make sure you have good visibility along the route.
- Use the rear-view mirrors frequently.
- Drive around obstacles.
- Never drive on the edge of a ditch or steep slope.
- It is dangerous to use two machines simultaneously to handle heavy or bulky loads, since this operation requires particular precautions to be taken. It must only be used exceptionally and after risk analysis.
- The ignition switch has an emergency stop mechanism in case of an operating anomaly occurring in the case of machines not fitted with a punch-operated cut-out.

INSTRUCTIONS

- Always drive the machine with the forks or attachment in the transport position, i.e., 300 mm from the ground, the telescopic arm retracted and the forks carriage sloping backward.
- For machines with gearboxes, use the recommended gear (↩ 2 - DESCRIPTION: INSTRUMENTS AND CONTROLS).
- Select the steering mode appropriate for the use and/or working conditions (↩ 2 - DESCRIPTION: INSTRUMENTS AND CONTROLS) (depending on machine model).
- Deactivate the parking brake.
- Shift the forward/reverse selector to the selected direction of travel and accelerate gradually until the machine moves off.

⚠ IMPORTANT ⚠

Starting and moving the machine on a slope may be a real hazard.

If the machine is parked or stopped, adhere scrupulously to the following instructions for moving it:

- Press the brake pedal.

- Release the parking brake.

- Engage the appropriate gear. (depending on machine model)

- Select forward or reverse direction.

- Ensure that there is no one or anything impeding the movement of the machine.

- Release the brake pedal and accelerate the engine.

The use of the machine loaded or with a trailer increases the risk. In this case, remain extremely vigilant.

Each braking system operates independently.

In an emergency, use the brake pedal and/or the manual parking brake to immobilize the machine.

With the engine off, release the manual parking brake only after restarting the engine and making sure that the brake pedal is functional.

G - STOPPING THE MACHINE

SAFETY INSTRUCTIONS

- Never leave the ignition key in the machine during the operator's absence.
- When the machine is stationary, or if the operator has to leave his cab (even for a moment), place the forks or attachment on the ground, apply the parking brake and place the forward/reverse selector in neutral.
- Make sure that the machine is not stopped in any position that will interfere with the traffic flow and at less than one meter from the track of a railway.
- In the event of prolonged parking on a site, protect the machine from bad weather, particularly from frost (check the level of antifreeze), and close and lock all the machine accesses (doors, windows, cowls, etc.).

INSTRUCTIONS

- Park the machine on level ground.
- When parking on slopes of less than 15%, position the machine perpendicular to the slope.
- The slope must not exceed 15%.
- Press and hold the brake pedal.
- Set the forward/reverse selector to neutral.
- Activate the parking brake.
- Release the brake pedal.
- The machine must be stationary before leaving the driver's cab.
- Fully retract the telescopic arm.
- Lower the forks or attachment to rest on the ground.
- When using an attachment with a grab or jaws, or a bucket with hydraulic opening, close the attachment fully.
- Before stopping the machine after intensive work, leave the engine idling for a few moments to allow the coolant and oil to lower the temperature of the engine and transmission. Do not forget this precaution, in the event of frequent stops or warm stalling of the engine, or else the temperature of certain parts will rise significantly due to the stopping of the cooling system, with the risk of badly damaging such parts.
- Stop the engine with the ignition switch and remove the key.
- Lock all the openings to the machine (doors, windows, cowls, etc.).
- Turn the battery cut-off to the "OFF" position in accordance with the recommendations (↩ 2 - DESCRIPTION).

H - DRIVING THE MACHINE ON THE PUBLIC HIGHWAY

(or see current legislation in other countries)

FRENCH ROAD TRAFFIC RULES

- The driving of non-type-approved "Tractor" machines on the public highway is subject to the provisions of the French Highway Code relating to special machines, defined in Article R.311-1 of the French Highway Code, in category B of the Equipment Order of November 20, 1969, which determines the procedures applicable to special machines. The machine must be fitted with an operating license plate.
- The driving of type-approved "Tractor" machines on the public highway is subject to the provisions of the French Highway Code relating to agricultural tractors, defined in Article R.311-1 of the French Highway Code. The machine must be licensed.
- The machine must be driven on the public highway in accordance with the instructions given in the manual supplied with the machine (Gross weight, Gross combination weight, towing load, axle loads, maximum speeds, etc. according to the type/version). The operator must be in possession of the machine's registration document.
- The operator must hold an HGV license, unless granted an exemption.
- When towing a trailer or agricultural equipment, the travel speed of the machine is limited to 25 km/h. In this case, a "25" disc must be affixed to the rear of the convoy.

GERMAN ROAD TRAFFIC RULES

⚠ IMPORTANT ⚠

For machines with the "Allgemeine Betriebserlaubnis" (general operating permit or ABE, in accordance with Article 20 of the StVZO "Straßenverkehrs-Zulassungsordnung"), follow the instructions below:

- Disconnect the reversing sound alarm before using a machine with a general operating permit (ABE) on the public highway.

⚠ IMPORTANT ⚠

Always reconnect the sound alarm before handling on private roads.

- Before you use the machine for handling operations on private roads:
 - Make sure that the machine's reversing sound alarm is connected and working properly.
 - Perform a functional test by putting the machine into reverse gear.
 - The audible alarm sounds.
 - Do not use the machine if the audible alarm is not working. Check the audible alarm's connection and repeat the test. Consult your dealer if the problem persists.

SAFETY INSTRUCTIONS

- Operators driving on the public highway must comply with current highway code legislation.
- The machine must comply with current road legislation. If necessary, there are optional solutions. Contact your dealer.

INSTRUCTIONS

- Make sure the revolving light is in place, switch it on and verify its operation.
- Make sure the lights, turn signals and windshield wipers are working properly.
- Check the cleanliness of the machine's mudguards.
- Check the general cleanliness of the machine before driving on public roads.
- Switch off the worklights if the machine is fitted with them.
- Select the steering mode "HIGHWAY TRAFFIC" (↔ - DESCRIPTION: INSTRUMENTS AND CONTROLS) (depending on machine model).
- Fully retract the telescopic arm and set the attachment approximately 300 mm off the ground.
- Put the frame leveling in the central position, i.e., the transverse axis of the axles parallel to the frame (depending on the machine model).
- Fully raise the stabilizers and turn the shoes inwards (depending on the machine model).

⚠ IMPORTANT ⚠

Never coast in neutral (forward/reverse selector or gear lever in neutral or transmission cut-off button pressed) to preserve the machine's engine brake. Failure to observe this instruction on a slope will lead to excessive speed, which may make the machine uncontrollable (steering, brakes) and cause serious mechanical damage.

DRIVING THE MACHINE WITH A FRONT-MOUNTED ATTACHMENT

- You must comply with current regulations in your country, covering the possibility of driving on the public highway with a front-mounted attachment on your machine.
- If road legislation in your country authorizes circulation with a front-mounted attachment, you must at least:
 - Protect and report any sharp and/or dangerous edges on the attachment (↖ 4 - ADAPTABLE ATTACHMENTS AVAILABLE ON THE RANGE).
 - The attachment must not be loaded.
 - Make sure that the attachment does not mask the lighting range of the forward lights.
 - Make sure that current legislation in your country does not require other obligations.

OPERATING THE MACHINE WITH A TRAILER

- For using a trailer, observe the regulations in force in your country (maximum travel speed, braking, maximum weight of trailer, etc.).
- Do not forget to connect the trailer's electrical equipment to that of the machine.
- The trailer's braking system must comply with current legislation.
- If pulling a trailer with assisted braking, the tractor machine must be equipped with a trailer braking mechanism. In this case, do not forget to connect the trailer braking equipment to that of the machine.
- The vertical force on the towing hook must not exceed the maximum authorized by the manufacturer (consult the manufacturer's plate on your machine).
- The authorized gross vehicle weight must not exceed the maximum weight authorized by the manufacturer (↖ 2 - DESCRIPTION: SPECIFICATIONS).

IF NECESSARY, CONSULT YOUR DEALER.

INSTRUCTIONS FOR HANDLING A LOAD

A - CHOICE OF ATTACHMENTS

- Only attachments approved and authorized by MANITOU can be used on its machines.
- Make sure the attachment is suitable for the work to be done (◀ 4 - ADAPTABLE ATTACHMENTS AS OPTIONS ON THE RANGE).
- If the machine is equipped with the single sideshift attachment OPTION (TSDL), use only the authorized attachments (◀ 4 - ADAPTABLE ATTACHMENTS AS OPTIONS ON THE RANGE).
- Make sure the attachment is correctly installed and locked onto the machine carriage.
- Make sure that your machine attachments are working properly.
- Comply with the load chart limits for the machine for the attachment used.
- Do not exceed the rated capacity of the attachment.
- Never lift a slung load without the attachment provided for the purpose, as there is a risk of the sling slipping (◀ INSTRUCTIONS FOR HANDLING A LOAD: H - PICKING UP AND PUTTING DOWN A SUSPENDED LOAD).
- Do not handle loads suspended by straps directly on the forks (e.g. big bags), as there is a risk of shearing on sharp edges. Use an attachment designed for this purpose.

B - WEIGHT OF LOAD AND CENTER OF GRAVITY

- Before picking up a load, you must know its weight and its center of gravity.
- The longitudinal position of the center of gravity in relation to the heel of the forks (Fig. B1) is defined on the load chart for your machine (◀ 2 - DESCRIPTION: DIMENSIONS AND LOAD CHARTS). For loads with center of gravity exceeding this distance, contact your dealer.
- For irregular loads, determine the transverse center of gravity before any handling (fig. B2) and set it in the longitudinal axis of the machine.

⚠ IMPORTANT ⚠

*It is forbidden to handle a load heavier than the effective capacity defined on the machine load chart.
For loads with a moving center of gravity (e.g. liquids), take account of the variations in the center of gravity in order to determine the load to be handled and be extra vigilant and careful to limit these variations as far as possible.*

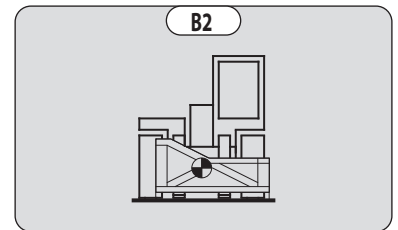
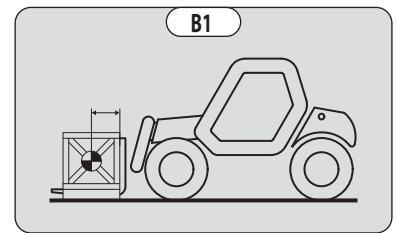

C - LONGITUDINAL STABILITY LIMITER AND WARNING DEVICE

This device gives an indication of the longitudinal stability of the machine, and limits hydraulic movements in order to ensure this stability, at least under the following operating conditions:

- when the machine is at a standstill,
 - when the machine is on firm, stable and consolidated ground,
 - when the machine is performing handling and placing operations.
- Move the boom very carefully when approaching the authorized load limit (◀ 2 - DESCRIPTION: INSTRUMENTS AND CONTROLS).
 - Always watch this device during handling operations.
 - If the "AGGRAVATING" hydraulic movements are cut off, perform only de-aggravating hydraulic movements in the following order (Fig. C): if necessary, raise the boom (1), retract the boom as far as possible (2) and lower the boom (3) to put down the load.

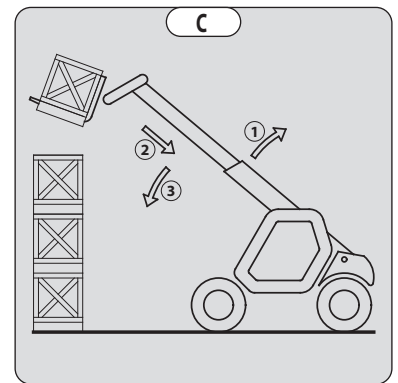

⚠ IMPORTANT ⚠

*The instrument reading may be erroneous when the steering is at full lock or the rear axle is oscillated to its maximum extent.
Before lifting a load, ensure that the machine is not in any of these situations.*

D - TRANSVERSE ATTITUDE OF THE MACHINE

Depending on machine model

The transverse attitude is the transverse slope of the frame with respect to the horizontal. Raising the boom reduces the machine's lateral stability. The machine's transverse attitude must be set with the boom in the down position as follows:

1 - MACHINE WITHOUT FRAME LEVELING USED ON TIRES

- Position the machine so that the bubble in the level is between the two lines (↖ 2 - DESCRIPTION: INSTRUMENTS AND CONTROLS).

2 - MACHINE WITH FRAME LEVELING USED ON TIRES

- Correct the tilt using the hydraulic control and check the horizontality with the spirit level. The bubble of the level must be between the two lines (↖ 2 - DESCRIPTION: INSTRUMENTS AND CONTROLS).

3 - MACHINE USED ON STABILIZERS

- Set the two stabilizers on the ground and raise the two front wheels of the machine (fig. D1).
- Correct the tilt using the stabilizers (Fig. D2) and check the horizontality with the spirit level. The bubble of the level must be between the two lines (↖ 2 - DESCRIPTION: INSTRUMENTS AND CONTROLS). In this position, the two front wheels must be off the ground.

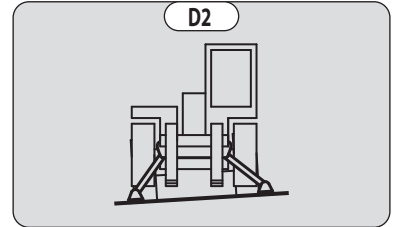
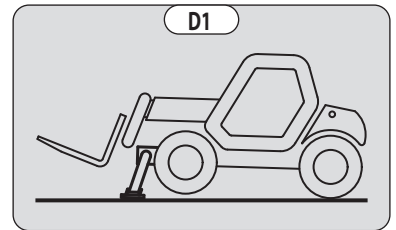

E - PICKING UP A LOAD ON THE GROUND

- Approach the machine perpendicular to the load, with the boom retracted and the forks in a horizontal position (fig. E1).
- Adjust the fork spacing and centering relative to the load to ensure stability (Fig. E2) (optional solutions exist, consult your dealer).
- Never lift a load with a single fork.

⚠ IMPORTANT ⚠

Beware of the risks of trapping or squashing limbs when manually adjusting the forks.

- Move the machine forward slowly (1) and bring the forks up to the stop in front of the load (Fig. E3). If necessary, slightly lift the boom (2) while picking up the load.
- Bring the load into the transport position.
- Tilt the load far enough backward to ensure stability (loss of load on braking or going downhill).

FOR A NON-PALLETIZED LOAD

- Tilt the carriage (1) forwards and move the machine slowly forwards (2), to insert the fork under the load (Fig. E4) (chock the load if necessary).
- Continue to move the machine (2) forward, tilting the carriage (3) (fig. E4) backward to position the load on the forks and check the load's longitudinal and lateral stability.

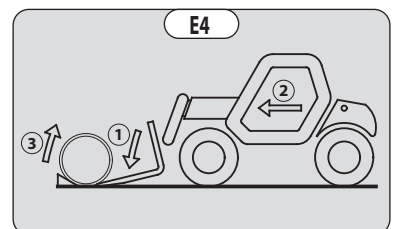
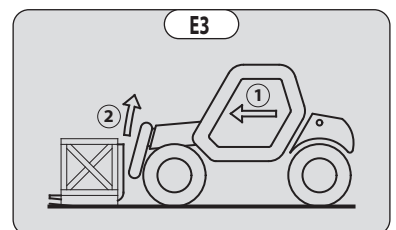
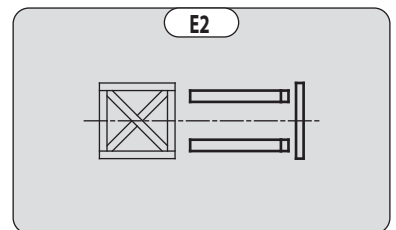
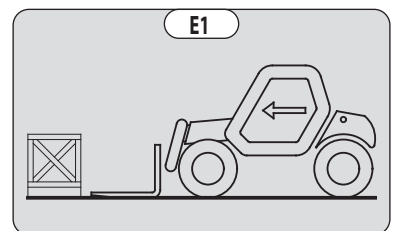

F - PICKING UP AND PUTTING DOWN A HIGH LOAD ON TIRES

⚠ IMPORTANT ⚠

You must not raise the boom if you have not checked the transverse attitude of the machine (← INSTRUCTIONS FOR HANDLING A LOAD D - TRANSVERSE ATTITUDE OF THE MACHINE).

REMINDER: Make sure that the following operations can be performed with good visibility (← OPERATING INSTRUCTIONS UNLADEN AND LADEN: D - VISIBILITY).

PICKING UP A HIGH LOAD ON TIRES

- Ensure that the forks will easily pass under the load.
- Raise and extend the boom (1) (2) until the forks are at the level of the load. If necessary, move the machine (3) forward (fig. F1), driving very slowly and carefully.
- Always remember to keep the distance necessary for inserting the forks under the load, between the stack and the machine (fig. F1) and use the shortest possible length of boom.
- Insert the forks under the load as far as they will go by alternately extending and lowering the boom (1) or, if necessary, moving the machine forward (2) (fig. F2). Activate the parking brake and place the forward/reverse selector in neutral.
- Lift the load slightly (1) and tilt the carriage (2) backwards to stabilize the load (Fig. F3).
- Tilt the load sufficiently backward to ensure its stability.
- Monitor the longitudinal stability limiter and warning device (← INSTRUCTIONS FOR HANDLING A LOAD: C - LONGITUDINAL STABILITY LIMITER AND WARNING DEVICE). If it is overloaded, set the load back down in the place from which it was picked up.
- If possible, lower the load without moving the machine. Raise the boom (1) to release the load, retract (2) and lower the jib (3) to set the load into transport position (fig. F4).
- If this is not possible, reverse the machine (1), maneuvering very gently and carefully to release the load. Retract (2) and lower the boom (3) to bring the load into the transport position (fig. F5).

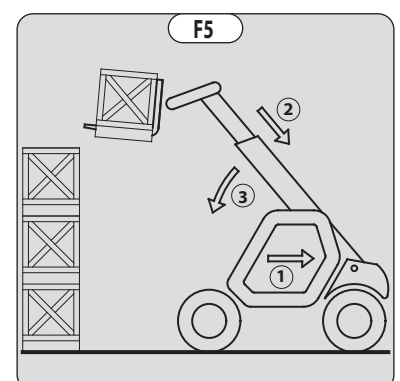
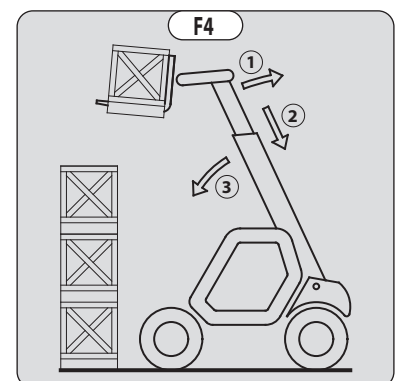
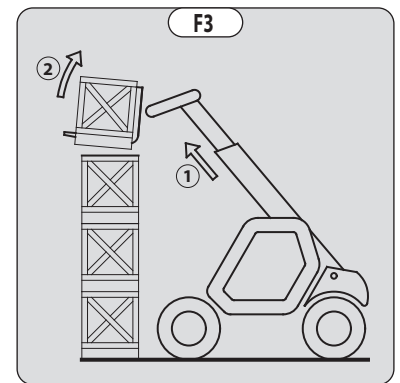
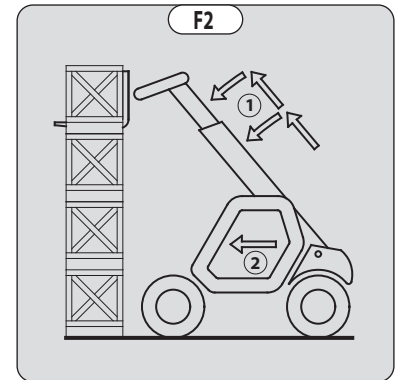
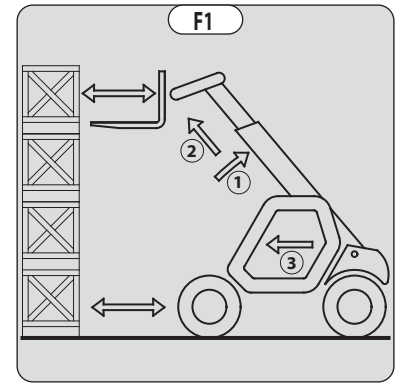

PUTTING DOWN A HIGH LOAD ON TIRES

- Approach the load in the transport position in front of the stack (Fig. F6).
- Activate the parking brake and place the forward/reverse selector in neutral.
- Raise and extend the boom (1) (2) until the load is above the stack, while monitoring the longitudinal stability limiter and warning device (☞ INSTRUCTIONS FOR HANDLING A LOAD: C - LONGITUDINAL STABILITY LIMITER AND WARNING DEVICE). If necessary, move the machine (3) forward (fig. F7), driving very slowly and carefully.
- Place the load in a horizontal position and put it down on the pile by lowering and retracting the boom (1) (2) in order to position the load correctly (Fig. F8).
- If possible, release the forks by alternately retracting and raising the boom (1) (Fig. F9). Then set the forks into transport position.
- If this is not possible, reverse the machine (1), maneuvering very slowly and carefully to release the forks (fig. F10). Then set the forks into transport position.

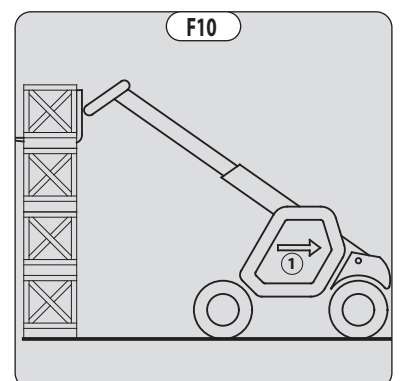
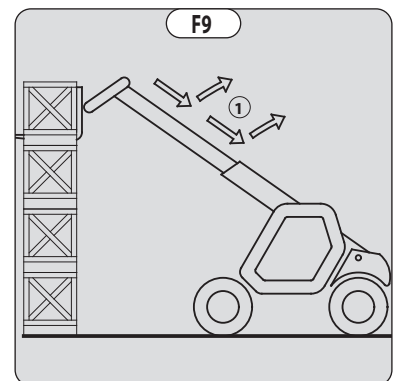
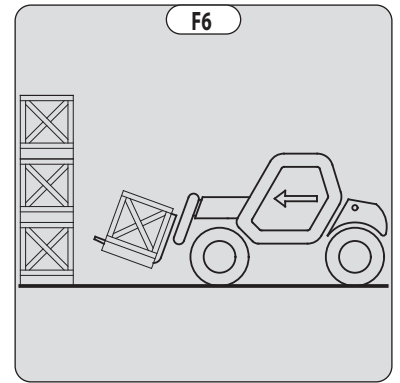

G - PICKING UP AND PUTTING DOWN A HIGH LOAD ON STABILIZERS

Depending on machine model

⚠ IMPORTANT ⚠

You must not raise the boom if you have not checked the transverse attitude of the machine (← INSTRUCTIONS FOR HANDLING A LOAD D - TRANSVERSE ATTITUDE OF THE MACHINE).

REMINDER: Make sure that the following operations can be performed with good visibility (← OPERATING INSTRUCTIONS UNLADEN AND LADEN: D - VISIBILITY).

The stabilizers are used to optimize the machine's lifting performance (← 2 - DESCRIPTION: INSTRUMENTS AND CONTROLS).

POSITIONING THE STABILIZERS WITH THE FORKS IN TRANSPORT POSITION (UNLADEN AND LADEN)

- Set the forks in transport position in front of the elevation.
- Stay far enough away to allow the boom to be raised.
- Activate the parking brake and place the forward/reverse selector in neutral.
- Set the two stabilizers on the ground and lift the two front wheels of the machine (fig. G1), while maintaining its transverse stability.

RAISING THE STABILIZERS WITH THE FORKS IN TRANSPORT POSITION (UNLADEN AND LADEN)

- Raise both stabilizers fully and at the same time.

LOWERING THE STABILIZERS WITH JIB UP (UNLADEN AND LADEN)

⚠ IMPORTANT ⚠

This operation must be exceptional and performed with great care.

- Raise the boom and retract the telescopes completely.
- Set the machine in position in front of the elevation (fig. G2), moving very slowly and carefully.
- Activate the parking brake and place the forward/reverse selector in neutral.
- Move the stabilizers very slowly and gradually as soon as they are close to the ground or in contact with it.
- Lower the two stabilizers and lift the two front wheels of the machine (fig. G3). During this operation, transverse attitude must be permanently maintained: the bubble in the level must be kept between the two lines.

SETTING THE STABILIZERS WITH THE BOOM UP (UNLADEN AND LADEN)

⚠ IMPORTANT ⚠

This operation must be exceptional and performed with great care.

- Keep the boom raised and retract the telescopes completely (Fig. G3).
- Move the stabilizers very slowly and gradually as soon as they are in contact with the ground and when they leave the ground. During this operation, transverse attitude must be permanently maintained: the bubble in the level must be kept between the two lines.
- Raise both stabilizers completely.
- Deactivate the parking brake and reverse the machine (1) very slowly and carefully to release it and lower the forks (2) into transport position (fig. G4).

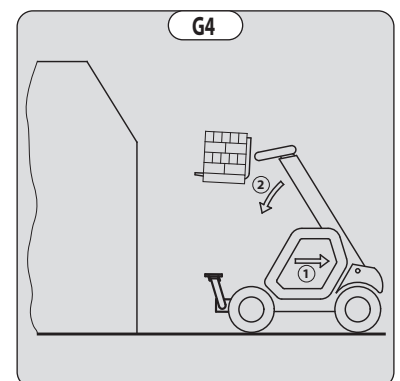
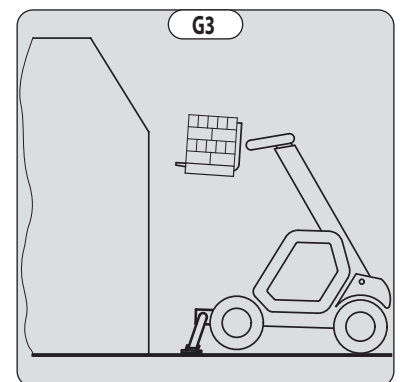
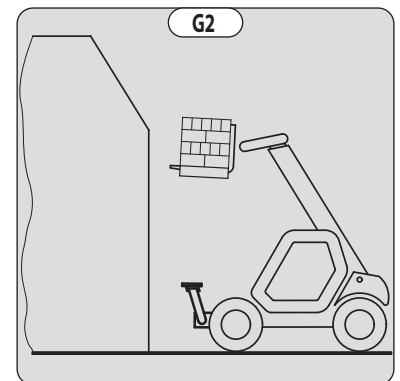
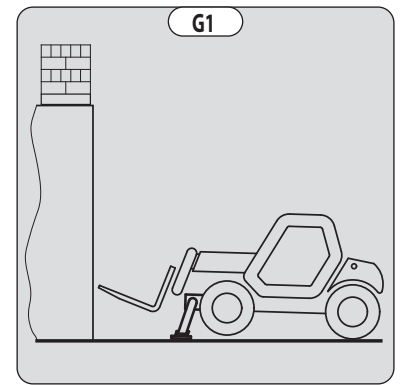

PICKING UP A HIGH LOAD ON STABILIZERS

- Ensure that the forks will easily pass under the load.
- Check the position of the machine with respect to the load and make a test run, if necessary, without picking up the load.
- Raise and extend the boom (1) (2) until the forks are at the level of the load (Fig. G5).
- Bring the forks to the stop in front of the load by alternately extending and lowering the boom (1) (Fig. G6).
- Lift the load slightly (1) and tilt the carriage (2) backwards to stabilize the load (Fig. G7).
- Monitor the longitudinal stability limiter and warning device (← INSTRUCTIONS FOR HANDLING A LOAD: C - LONGITUDINAL STABILITY LIMITER AND WARNING DEVICE). If it is overloaded, set the load back down in the place from which it was picked up.
- If possible, lower the load without moving the machine. Raise the boom (1) to release the load, retract (2) and lower the jib (3) to set the load into transport position (fig. G8).

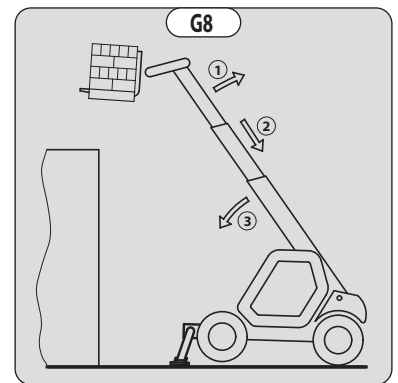
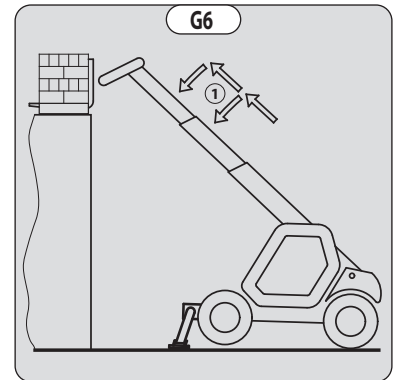
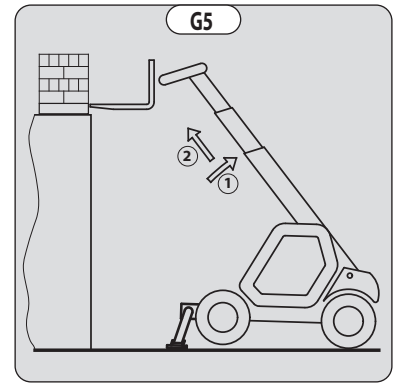

SETTING DOWN A HIGH LOAD ON STABILIZERS

- Raise and extend the boom (1) (2) until the load is above the elevation (Fig. G9), while monitoring the longitudinal stability limiter and warning device (← INSTRUCTIONS FOR HANDLING A LOAD: C - LONGITUDINAL STABILITY LIMITER AND WARNING DEVICE).
- Position the load horizontally and release it by lowering and retracting the boom (1) (2) to position the load correctly (Fig. G10).
- Free the forks by alternately retracting and raising the boom (3) (Fig. G11).
- If possible, set the boom in transport position without moving the machine.

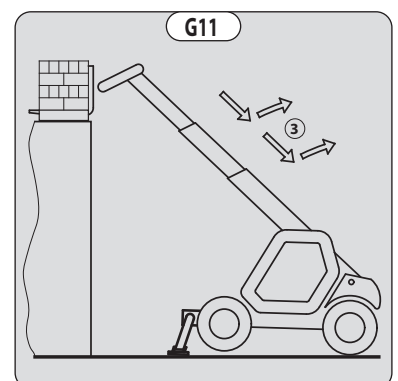
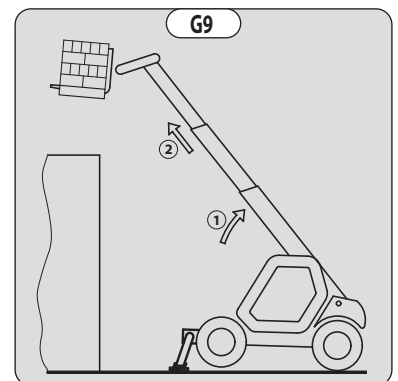

H - PICKING UP AND PUTTING DOWN A SUSPENDED LOAD

⚠ IMPORTANT ⚠

*Failure to follow the above instructions may lead the machine to lose stability and overturn.
MUST be used with a machine equipped with an operational hydraulic movement cut-off device.*

CONDITIONS OF USE

- The length of the sling or the chain shall be as short as possible to limit swinging of the load.
- Lift the load vertically along its axis, never by pulling sideways or lengthways.

HANDLING WITHOUT MOVING THE MACHINE

- Whether on stabilizers or on tires, the lateral attitude must not exceed 1% and the longitudinal attitude must not exceed 5%: the bubble of the level must be held at "0".
- Ensure that the wind speed is not higher than 10 m/s.
- Ensure that there is no one between the load and the machine.

I - TRAVELING WITH A SUSPENDED LOAD

- Before moving, inspect the terrain in order to avoid excessive slopes and cross-falls, bumps and potholes, or soft ground.
- Ensure that the wind speed is not higher than 36 km/h.
- The machine must not travel at more than 0.4 m/s (1.4 km/h, i.e. one quarter walking speed).
- Drive and stop the machine gently and smoothly to minimize swinging of the load.
- Carry the load a few centimeters above the ground (max. 30 cm) the shortest possible jib length. Do not exceed the offset indicated on the load chart. If the load begins to swing excessively, do not hesitate to stop and lower the jib to set down the load.
- Before moving the machine, check the longitudinal stability limiter and warning device (☞ 2 - DESCRIPTION: INSTRUMENTS AND CONTROLS), only the green LEDs and possible the yellow LEDs should be lit
- During transport, the lift truck operator must be assisted by a person on the ground (standing a minimum of 3 m from the load), who will limit swinging of the load using a bar or a rope. Ensure that this person is always clearly in view.
- The lateral attitude must not exceed 5%: the bubble in the level must be kept between the two "MAX" marks.
- The longitudinal attitude must not exceed 15% with the load facing uphill and 10% with the load facing downhill.
- The boom angle must not exceed 45°.
- If the first red LED of the longitudinal stability limiter and warning device (☞ 2 - DESCRIPTION: INSTRUMENTS AND CONTROLS) comes on while traveling, gently bring the machine to a halt and stabilize the load. Retract the telescope to reduce the offset of the load.

INSTRUCTIONS FOR USE AS A LOADER

For agricultural-type machines (MLT range)

A - LOADING

⚠ IMPORTANT ⚠

You must not raise the boom if you have not checked the transverse attitude of the machine (← INSTRUCTIONS FOR HANDLING A LOAD D - TRANSVERSE ATTITUDE OF THE MACHINE).

REMINDER: Make sure that the following operations can be performed with good visibility (← OPERATING INSTRUCTIONS UNLADEN AND LADEN: D - VISIBILITY).

FILLING THE BUCKET

- Place the bottom of the bucket in a horizontal position, just in contact with the ground (1) (Fig. A1).
- Move forward gradually (2) while simultaneously raising the boom and tilting the bucket backwards (3), for improved filling and breakout (Fig. A1).
- Reverse the machine (1) very carefully and gently to free the bucket. Lower the boom (2) into the transport position (Fig. A2).

⚠ IMPORTANT ⚠

Tilt the bucket sufficiently back to avoid spilling product and ensure its stability (loss of product under braking).

LOADING A TRAILER

- Approach the side of the trailer in the transport position (Fig. A3).
- Raise and extend the boom (1) (2) until the bucket is above the trailer, while monitoring the longitudinal stability limiter and warning device (← INSTRUCTIONS FOR HANDLING A LOAD: C - LONGITUDINAL STABILITY LIMITER AND WARNING DEVICE) (Fig. A4).
- Drive the machine forward (3) very carefully and gently so that the bucket empties its load in the center of the trailer (Fig. A4).
- Immobilize the machine with the brake pedal and put the reversing shift lever in neutral.

N.B.: Immobilizing the machine with the brake pedal means that the transmission should be in neutral. Failure to follow this recommendation may lead to overheating and damage to the brakes.

- Slowly discharge the product (4) (Fig. A4).
- Tilt the bucket backwards (1) and reverse the machine (2) very carefully and gently (Fig. A5).
- Retract (3) and lower the boom (4) into the transport position (Fig. A5).

B - BACKFILLING

- Place the bottom of the bucket in a horizontal position, just in contact with the ground (1) (Fig. B1).
- Drive forward gradually (2). Once filled, the bucket will act as a leveling blade (Fig. B1).

⚠ IMPORTANT ⚠

When driving, beware of trenches as well as recently excavated and/or backfilled ground.

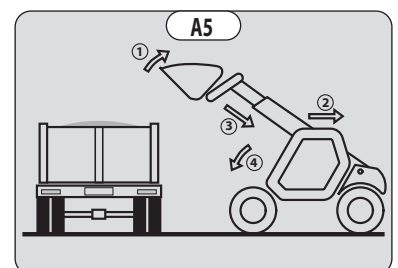
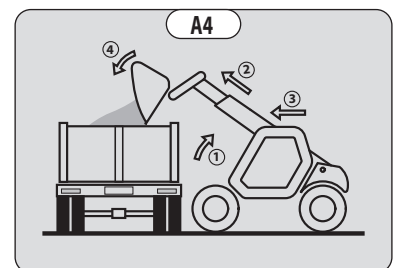
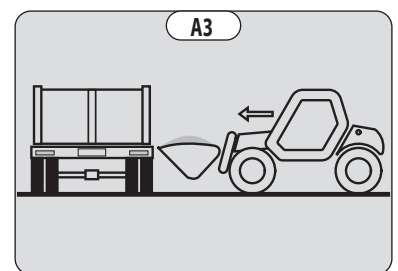

INSTRUCTIONS FOR USING THE MOBILE ELEVATING WORK PLATFORM

For machines equipped with a MOBILE ELEVATING WORK PLATFORM

A - AUTHORIZATION FOR USE

- Operation of the platform requires further authorization in addition to that of the machine.

B - SUITABILITY OF THE PLATFORM FOR THE JOB

- Our machines fitted with mobile elevating work platforms are compliant with standard **EN 280** for Europe and standard **AS/NZS 1418.10:2011** for Australia, corresponding to the classification of Group C1 to C3 in accordance with this standard.
- MANITOU has ensured that this platform is suitable for use under the normal operating conditions provided in this operator's manual, with a STATIC test coefficient of 1.25 and a DYNAMIC test coefficient of 1.1 as specified in harmonized European standard **EN 280** for mobile elevating work platforms.
- Before commissioning, the company manager must make sure that the platform is appropriate for the work to be done, and perform certain tests (in accordance with current legislation).

C - PROVIDED ON THE PLATFORM

- Wear suitable clothing when using the platform, avoid loose-fitting garments.
- Never use the platform with hands or shoes that are wet or soiled with greasy substances.
- Remain alert at all times when using the platform. Do not listen to the radio or music using headphones or earphones.
- MANITOU strongly recommends wearing a safety harness attached to an attachment point in the platform. Wearing a safety harness or other personal protection equipment against falls may be compulsory. Comply with local, government and national regulations in force, employer's safety rules and work site regulations .
- The safety harness or other personal protection equipment against falls must comply with local, government, and national regulations in force. They must be inspected in accordance with the regulations in force.
- The control units must never be used for any other than their intended purposes (e.g. Climbing onto or down from the machine, coat hanger, etc.).
- Safety helmets must be worn.
- The operator must always be in his normal position in the driver's cab: it is prohibited to have arms or legs, or generally any part of the body, outside the platform.
- Ensure that materials loaded onto the platform (pipes, cables, containers, etc.) cannot fall out. Do not pile these materials to the point where it is necessary to step over them.

D - USING THE PLATFORM

- However experienced they may be, operators must acquaint themselves with the emplacement and operation of all control instruments prior to operating the platform.
- Check before use that the platform has been correctly assembled and locked onto the machine.
- Do not enter or exit the platform unless it is fully lowered.
- Always enter and exit the platform through the gate or using the sliding intermediate cross members (depending on the model).
- Always enter and exit facing the interior of the platform.
- Always use both hands and one foot or both feet and one hand to enter and exit the platform.
- Make sure that the sliding intermediate cross members (depending on the model) are in the lower position and that the gate is properly closed (depending on the model) before using this platform.
- Do not attach the sliding mid rails in the high position.
- The platform should be operated in an area free of any obstructions or danger when it is lowered to the ground.
- The operator using the platform must be aided by someone on the ground with adequate training.
- You should stay within the limits set out in the platform load chart.
- The lateral constraints are limited (↩ 2 - DESCRIPTION: SPECIFICATIONS).
- It is strictly forbidden to suspend a load from the platform or the machine's boom without an attachment provided for the purpose (↩ INSTRUCTIONS FOR HANDLING A LOAD: H - PICKING UP AND PUTTING DOWN A SUSPENDED LOAD).
- The platform cannot be used as a crane or a lift for permanently transporting people or materials, nor as jacks or supports.
- The machine must not be moved with one (or more) person(s) on the platform.
- It is forbidden to transport people on the platform using the hydraulic controls in the machine's cab (except in case of rescue).
- The operator must not climb onto to off the platform when it is not on ground level (jib retracted and in the down position).
- The machine must not be fitted with unauthorized attachments that increase the windage of the assembly.
- Do not use ladders or improvised structures on the platform to gain extra height.
- Do not climb onto the rails of the platform to gain extra height.
- It is forbidden to use the platform on forks. The fork slots are only to, be used for storing the platform and not for lifting people under any circumstances.

E - ENVIRONMENT

- Respect a safety distance between power lines or live components and any part of the body, any conductive object or any part of the machine, unless the local, government and national applicable regulations, the safety rules of the employer or construction site regulations are more strict in terms of distance required.
- Allow for platform movement and swaying or sagging power lines.

⚠ IMPORTANT ⚠

It is forbidden to use the platform close to electricity cables. Maintain the specified safe distances.

RATED VOLTAGE (VOLTS)	SAFETY DISTANCE (METERS)
50 < U < 1000	2,30 M
1000 < U < 30000	2,50 M
30000 < U < 45000	2,60 M
45000 < U < 63000	2,80 M
63000 < U < 90000	3,00 M
90000 < U < 150000	3,40 M
150000 < U < 225000	4,00 M
225000 < U < 400000	5,30 M
400000 < U < 750000	7,90 M

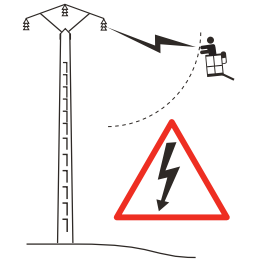

⚠ IMPORTANT ⚠

It is strictly forbidden to use the platform when the wind speed exceeds 45 km/h.

- To visually recognize this wind speed, refer to the empirical wind evaluation scale below:

BEAUFORT scale (wind speed at a height of 10 m on a flat site)						
Force	Type of wind	Speed (knots)	Speed (km/h)	Speed (m/s)	Effects on Land	Sea conditions
0	Calm	0 - 1	0 - 1	< 0.3	Smoke rises vertically.	Sea is like a mirror.
1	Light air	1 - 3	1 - 5	0.3 - 1.5	Smoke indicates direction of wind.	Ripples with appearance of scale, no foam crests.
2	Light breeze	4 - 6	6 - 11	1.6 - 3.3	Wind felt on face, leaves rustle.	Short wavelets, but pronounced.
3	Gentle breeze	7 - 10	12 - 19	3.4 - 5.4	Leaves and small twigs in constant motion.	Very small waves, crests begin to break.
4	Moderate breeze	11 - 16	20 - 28	5.5 - 7.9	Wind raises dust and loose pieces of paper; small branches are moved.	Small waves, becoming longer, numerous whitecaps.
5	Fresh breeze	17 - 21	29 - 38	8 - 10.7	Small trees in leaf begin to sway.	Wavelets form on inland waters; moderate waves, taking longer form.
6	Strong breeze	22 - 27	39 - 49	10.8 - 13.8	Large branches in motion, whistling heard in overhead wires, umbrella use becomes difficult.	Larger waves forming, whitecaps everywhere, some spray.
7	Near gale	28 - 33	50 - 61	13.9 - 17.1	Whole trees in motion, inconvenience felt when walking against the wind.	Sea heaps up; white foam from breaking waves begins to be blown in streaks along the direction of the wind.
8	Gale	34 - 40	62 - 74	17.2 - 20.7	Wind breaks twigs off trees; impedes progress.	Moderately high waves of greater length; edges of crests begin to break into spindrift.
9	Strong gale	41 - 47	75 - 88	20.8 - 24.4	Wind damages roofs (chimneys, slates, etc.).	High waves, crests of waves begin to topple, streaks of foam; reduced visibility.
10	Storm	48 - 55	89 - 102	24.5 - 28.4	Seldom experienced inland; trees uprooted; considerable structural damage occurs.	Very high waves; white streaks of foam; reduced visibility.
11	Violent storm	56 - 63	103 - 117	28.5 - 32.6	Very rare, widespread damage.	Exceptionally high waves able to hide medium sized ships from view, reduced visibility.
12	Hurricane	64 +	118 +	32.7 +	Devastating damage.	Sea completely white; air filled with foam and spray, very reduced visibility.

F - MAINTENANCE

⚠ IMPORTANT ⚠

*Your platform must be periodically inspected to ensure its continued compliance.
The frequency of this inspection is defined by the legislation in force in the country in which the platform is used.
In France, a general periodic inspection every 6 months (Decree of March 1, 2004).*

INSTRUCTIONS FOR USING THE RADIO-CONTROL

For machines with RC radio control

HOW TO USE THE RADIO-CONTROL

SAFETY INSTRUCTIONS

⚠ IMPORTANT ⚠

It is prohibited to lift people in the platform using the radio-control.

It is prohibited to use the radio-control from the platform:

- This radio-control consists of electronic and mechanical safety elements. It cannot receive commands from another transmitter because the internal encoding is unique to each radio-control.

⚠ IMPORTANT ⚠

If it is used improperly or incorrectly, there is a risk of danger to:

- The physical and mental health of the user or others.

- The machine and other neighboring items.

Everyone working with this radio-control:

- Must be qualified in line with current regulations and trained accordingly.

- Must follow this instruction manual as closely as possible.

- The system is used to control the machine remotely via radio waves. Commands are also transmitted if the machine is out of sight (behind an obstacle or a building for example), this is why:
 - After stopping the truck and removing the key switch (only possible when it is stationary), always place the transmitter in a safe, dry place.
 - Before performing any installation, servicing or repair work, always switch off power sources (in particular, electric welding devices and electric head units on hydraulic distributors must be disconnected at each section).
 - Never remove or alter the safety devices (such as the hand-guard frame, key, emergency stop button, etc.).

⚠ IMPORTANT ⚠

Never drive the machine if it is not continuously and perfectly within view of the operator.

- Before leaving the transmitter, the operator must make sure that it cannot be used by an unauthorized third person: either by removing the key button from the transmitter or locking it in an inaccessible place.
- The user must ensure that the instruction manual is accessible at all times and that operators have read and understood it.

INSTRUCTIONS

- Take up position in a stable place with no risk of slipping.
- Before using the transmitter, make sure there is nobody within the working area.
- Only use the transmitter with its carrying device or installed correctly on the platform.

⚠ IMPORTANT ⚠

When you remove the transmitter, remove the accumulator and key button so that it cannot be used accidentally or deliberately by anyone else.

PROTECTIVE DEVICES

- The machine will be immobilized within a maximum of 450 milliseconds (approx. 0.5 second):
 - If the emergency stop button of the transmitter is pressed (50 milliseconds), or that of the machine.
 - If the transmission distance of the radio waves is exceeded.
 - If the transmitter is faulty.
 - If an interfering radio signal is received from elsewhere.
 - If the accumulator is removed from its housing in the transmitter.
 - If the battery reaches the end of its autonomy.
 - If the transmitter is switched off by turning the key switch to the off position.
- These protective devices are provided for the safety of personnel and property and must never be modified, removed or bypassed in any way whatsoever!
- The hand-guard frame prevents external action on a joystick (e.g. if the transmitter is dropped, or if the operator leans on a guard-rail).
- An electronic safety device prevents radio transmission from being initiated if the joysticks are not mechanically and electrically at rest and if the internal combustion engine speed selector is not set to idle.

⚠ IMPORTANT ⚠

In an emergency, press the transmitter emergency stop button immediately; then follow the manual's instructions (↩ 2 - DESCRIPTION: INSTRUMENTS AND CONTROLS).

MACHINE MAINTENANCE INSTRUCTIONS

GENERAL INSTRUCTIONS

⚠ IMPORTANT ⚠

Carefully read and understand this operator's manual before any operation on this machine.

Carry out all repairs immediately, even if the repairs concerned are minor.

Repair all leaks immediately, even if the leak concerned is minor.

Be careful of the risk of burns and splashing (exhaust, radiator, engine, hydraulic oil, etc.).

- Make sure the area is adequately ventilated before starting up the machine.
- Wear clothes suitable for the maintenance of the machine. Avoid wearing jewelry and loose clothes. Tie back and protect your hair, if necessary.
- Stop the engine and remove the ignition key before carrying out any work.

PLACING THE JIB SAFETY WEDGE

- The machine is equipped with a boom safety wedge (↔ 2 - DESCRIPTION: INSTRUMENTS AND CONTROLS) that must be installed on the lifting cylinder rod when working beneath the boom.

ACCORDING TO INSTALLATION

FITTING THE WEDGE

- Fully raise the jib.
- Place the safety wedge 1 on the rod of the lifting cylinder and secure with the rod 2 and the pin 3.
- Slowly lower the jib then stop the hydraulic movements before it comes into contact with the wedge.

REMOVING THE WEDGE

- Fully raise the jib.
- Remove the pin and the rod.
- Return the safety wedge to the storage location provided on the machine.

⚠ IMPORTANT ⚠

Only use the wedge supplied with the machine.

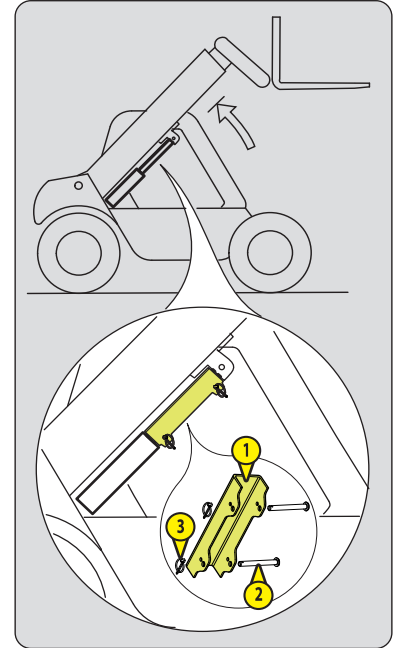

ACCORDING TO INSTALLATION

FITTING THE WEDGE

- Fully raise the jib.
- Loosen the thumbwheels 1.
- Assemble the parts of the safety wedge 2 around the cylinder rod and lock with the pins 3.

NOTE: the stop flats 4 of the safety wedge must be located towards the bottom of the lifting cylinder 5.

- Slowly lower the jib then stop the hydraulic movements before it comes into contact with the wedge.

REMOVING THE WEDGE

- Fully raise the jib.
- Remove the pins 3.
- Put the parts of the safety wedge 2 back on the machine and lock them with the thumbwheels 1.
- Replace the pins 3 on the parts of the safety wedge.

⚠ IMPORTANT ⚠

Only use the wedge supplied with the machine.

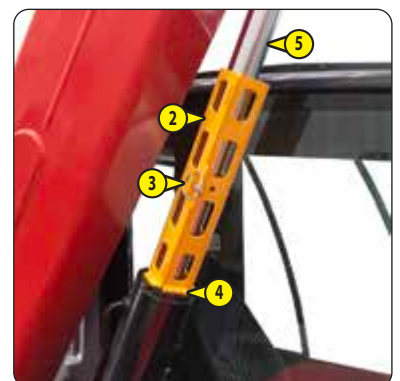
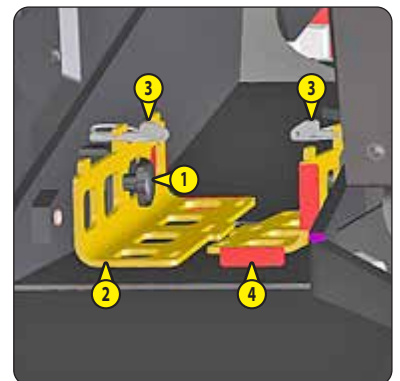

MAINTENANCE

- Perform the periodic service (↩ 3 - MAINTENANCE) to keep your machine in good working order. Failure to perform periodic maintenance may invalidate the contractual warranty.

MAINTENANCE LOGBOOK

- The maintenance operations carried out in accordance with the recommendations given in section 3 - MAINTENANCE and the other inspection, servicing or repair operations or modifications performed on the machine shall be recorded in a maintenance logbook.
- The entry for each operation should include the date of the work, the names of the individuals or companies having performed them, the type of operation and its frequency, if applicable.
- If machine elements are replaced, the part numbers of these elements shall be indicated.

LUBRICANT AND FUEL LEVELS

- Use the recommended lubricants (never use contaminated lubricants).
- Do not fill the fuel tank when the engine is running.
- Only fill up the fuel tank in areas specified for this purpose.
- Do not fill the fuel tank to the maximum level.
- Do not smoke or approach the machine with a flame when the fuel tank is open or is being filled.

HYDRAULICS

- Any work on the load handling hydraulic circuit is forbidden except for the operations described in chapter: 3 - MAINTENANCE.
- Do not attempt to loosen unions, hoses or any hydraulic component with the circuit under pressure.

⚠ IMPORTANT ⚠

COUNTERBALANCE VALVE: it is dangerous to change the setting or remove the counterbalance valves or safety valves which may be fitted to the cylinders of your machine.
HYDRAULIC ACCUMULATOR: dismantling hydraulic accumulators and their pipes which may be fitted on your machine is dangerous. Such operations must only be performed by approved personnel (consult your dealer).

ELECTRICITY

- Do not short-circuit the starter relay to start the engine. If the forward/reverse selector is not in neutral and the parking brake is not on, the machine may suddenly start to move.
- Do not place metal items on the battery.
- Disconnect the battery before working on the electrical circuit.

WELDING ON THE MACHINE

⚠ IMPORTANT ⚠

Welding operations on the machine for the purposes of maintenance or repairs must only be carried out by people authorized by MANITOU.

- Disconnect the battery before any welding operations on the machine.
- When carrying out electric welding work on the machine, connect the negative cable from the equipment directly to the part being welded so as to avoid very high current passing through the alternator.
- Never carry out welding or work which gives off heat on an assembled tire. The heat would increase the pressure which could cause the tire to explode.
- If the machine is equipped with an electronic control unit, disconnect it before starting to weld so as to avoid the risk of causing irreparable damage to electronic components.

WASHING THE MACHINE

⚠ IMPORTANT ⚠

When washing with a high pressure cleaner, avoid the engine air intakes, the cylinder rod wiper seals, the hinges, the structural components and the electrical connections, etc.

- Clean the machine or at least the area concerned before any intervention.
- Remember to close and lock all openings on the machine (doors, windows, cowls, etc.).
- If necessary, protect against penetration of water, steam or cleaning agents, components susceptible of being damaged, particularly electrical components and connections and the injection pump.
- Clean the machine of any traces of fuel, oil or grease.

TRANSPORTING THE MACHINE

⚠ IMPORTANT ⚠

Transporting the machine involves real risks for the operator and others involved.

- Towing, winching, slinging or transporting the machine (↩ 3 - MAINTENANCE).

PROLONGED MACHINE SHUTDOWN

INTRODUCTION

⚠ IMPORTANT ⚠

Procedures to follow for long duration standstill and for bringing back the machine into service must be performed by your dealership.

This period of long duration standstill must not exceed 12 months.

After 12 months, repeat the procedures for putting the machine back into service and long-term shutdown.

The recommendations below are intended to prevent the machine from being damaged when it is not used for a period of more than 3 months.

PREPARATION OF THE MACHINE

- Clean the machine thoroughly.
- Check and repair any fuel, oil, water or air leaks.
- Replace or repair any worn or damaged parts.
- Wash the painted surfaces of the machine in clear and cold water and wipe them.
- Touch up the paintwork if necessary.
- Lower the lifting structure fully.
- Retract the telescopic arms.
- Release the pressure in the hydraulic circuits.
- Shut down the machine.

DEF (Diesel Exhaust Fluid) TANK

Depending on machine model

- Drain down and rinse the DEF (Diesel Exhaust Fluid) tank.
- Replace the "DEF" (Diesel Exhaust Fluid) feed pump filter (↩ 3 - MAINTENANCE).
- Slowly fill the tank with new DEF up to the bottom of the filler neck.
- Start up the machine to pressurize the circuit and bring it up to working temperature, then shut down the engine.
- If necessary, top up the tank.

PROTECTING THE ENGINE

- Contact your dealer to obtain the procedure for protecting the inside of the engine (use of protection product).
- Fill the tank with fuel (↩ 3 - MAINTENANCE).
- Replace the engine oil and oil filter (↩ 3 - MAINTENANCE).
- Replace the coolant (↩ 3 - MAINTENANCE).
- Leave the engine running at idling speed for a few minutes, then switch off.
- Run the engine for a short time so that the oil and cooling liquid circulate inside.
- Disconnect the battery and store it in a safe place away from the cold, after charging it to maximum capacity.
- Block the outlet with waterproof adhesive tape.
- Remove the drive belts and store them in a safe place.
- Disconnect the engine cut-off solenoid on the injection pump and carefully insulate the connection.

MACHINE PROTECTION

Place the machine on level ground.

- Set the machine on axle stands so that the tires are off the ground.
- Deactivate the parking brake (depending on machine model).
- Protect cylinder rods which will not be retracted from corrosion.
- Wrap the wheels.

N.B.: If the machine is to be stored outdoors, cover it with a waterproof tarpaulin.

RETURNING THE MACHINE TO SERVICE



Make sure the area is adequately ventilated before starting up the machine.

- Remove the waterproof adhesive tape from all the orifices.
- Remove the protection from the cylinder rods and wheels.
- Refit and reconnect the battery.
- Activate the parking brake and remove the axle stands.
- Perform the daily maintenance operations (↩ 3 - MAINTENANCE).
- Perform the weekly maintenance operations (↩ 3 - MAINTENANCE).
- Drain and clean the fuel tank (↩ 3 - MAINTENANCE).
- Fill the fuel tank with clean diesel filtered through the filler port.
- Replace the fuel filter (↩ 3 - MAINTENANCE).
- Replace the fuel pre-filter (↩ 3 - MAINTENANCE) (depending on the model of machine).
- Drain and rinse the DEF tank (depending on the machine model).
- Top up, slowly fill the tank with new "DEF" (Diesel Exhaust Fluid) up to the bottom of the filler neck (depending on the machine model).
- Refit and set the tension in the belts. (↩ 3 - MAINTENANCE).
- Turn the engine over with the starter, to allow the oil pressure to rise.
- Reconnect the engine cut-off solenoid.
- Lubricate the machine completely (↩ 3 - MAINTENANCE).
- Start up the machine, following the operating and safety instructions (↩ OPERATING INSTRUCTIONS UNLADEN AND LADEN).
- Perform all the lifting structure's hydraulic movements up to the end position for each cylinder.

DISPOSING OF THE MACHINE

⚠ IMPORTANT ⚠

Consult your dealer before disposing of the machine.

RECYCLING OF MATERIALS

METALS

- Metals are 100% recoverable and recyclable.

PLASTICS

- Plastic parts are identified with a marking in accordance with current regulations.
- A limited range of materials is used to simplify the recycling process.
- The majority of the plastic components are made of "thermoplastic" plastics, which are easily recycled by melting, granulating or grinding.

RUBBER

- Tires and seals can be ground for use in cement manufacture or to obtain reusable granules.

GLASS

- Glass items can be removed and collected for processing by glaziers.

ENVIRONMENTAL PROTECTION

By entrusting the maintenance of your machine to the MANITOU network, the risk of pollution is limited and the contribution to environmental protection is made.

WORN OR DAMAGED PARTS

- Do not dump them in the countryside.
- MANITOU and its network have signed-up to a scheme of environmental protection through recycling.

USED OIL

- The MANITOU network organizes the collection and processing of used oil.
- By handing over your waste oil to MANITOU, the risk of pollution is limited.

USED BATTERIES

- Do not throw away batteries, as they contain metals that are harmful for the environment.
- Return them to the MANITOU network or any other approved collection point.

N.B.: MANITOU aims to manufacture machines that provide the best performance and limit polluting emissions.

2 - DESCRIPTION

2 - DESCRIPTION

<u>SAFETY PLATES AND STICKERS</u>	2-4
<u>MACHINE IDENTIFICATION</u>	2-8
<u>SPECIFICATIONS</u> ULM 412 H 36Y ST5 S1	2-12
<u>SPECIFICATIONS</u> ULM 415 H 36Y ST5 S1	2-14
<u>TIRES</u>	2-16
<u>DIMENSIONS</u> ULM 412 H 36Y ST5 S1 "ESSENTIAL" ULM 415 H 36Y ST5 S1 "ESSENTIAL"	2-18
<u>DIMENSIONS</u> ULM 412 H 36Y ST5 S1 "COMFORT" ULM 415 H 36Y ST5 S1 "COMFORT"	2-20
<u>DIMENSIONS</u> ULM 412 H 36Y ST5 S1 "CLASSIC" ULM 415 H 36Y ST5 S1 "CLASSIC"	2-22
<u>LOAD CHARTS</u> ULM 412 H 36Y ST5 S1	2-24
<u>LOAD CHARTS</u> ULM 415 H 36Y ST5 S1	2-25
<u>VISIBILITY</u>	2-26
<u>INSTRUMENTS AND CONTROLS</u>	2-28
<u>EMERGENCY BRAKE</u>	2-30
<u>EMERGENCY EXIT</u>	2-31
<u>TOWING DEVICE</u>	2-52
<u>OPTIONS - DRIVER'S CAB</u>	2-54
<u>OPTIONS - ENGINE/POWER</u>	2-58
<u>OPTIONS - LIFTING FUNCTIONS</u>	2-62
<u>OPTIONS - LIGHTS</u>	2-68
<u>OPTIONS - CHASSIS</u>	2-70
<u>OPTIONS - SAFETY</u>	2-72

SAFETY PLATES AND STICKERS

⚠ IMPORTANT ⚠

Clean all stickers and safety plates so that they are legible.
 Any safety plates and stickers which are illegible or damaged must be replaced.
 Check that stickers and safety plates are present after replacing any spare parts.

EXTERNAL PLATES AND STICKERS

ITEM	REFERENCE	DESCRIPTION
1	296998	- Manisopic safety instruction
2	24653	- Slings point
3	52563320	- Tie-down point
4	288430	- Repair instructions
5	268491	- Brake fluid instruction
6	305405	- Diesel fuel
7	52758072	- Battery cut-off instruction
8	234798	- Hydraulic fluid
9	52783878	- Boom safety
10	234805	- Hydraulic coupling instruction (OPTION)
11	289625	- Easy attachment connection (OPTION)
12	289013	- Towing instruction (OPTION)

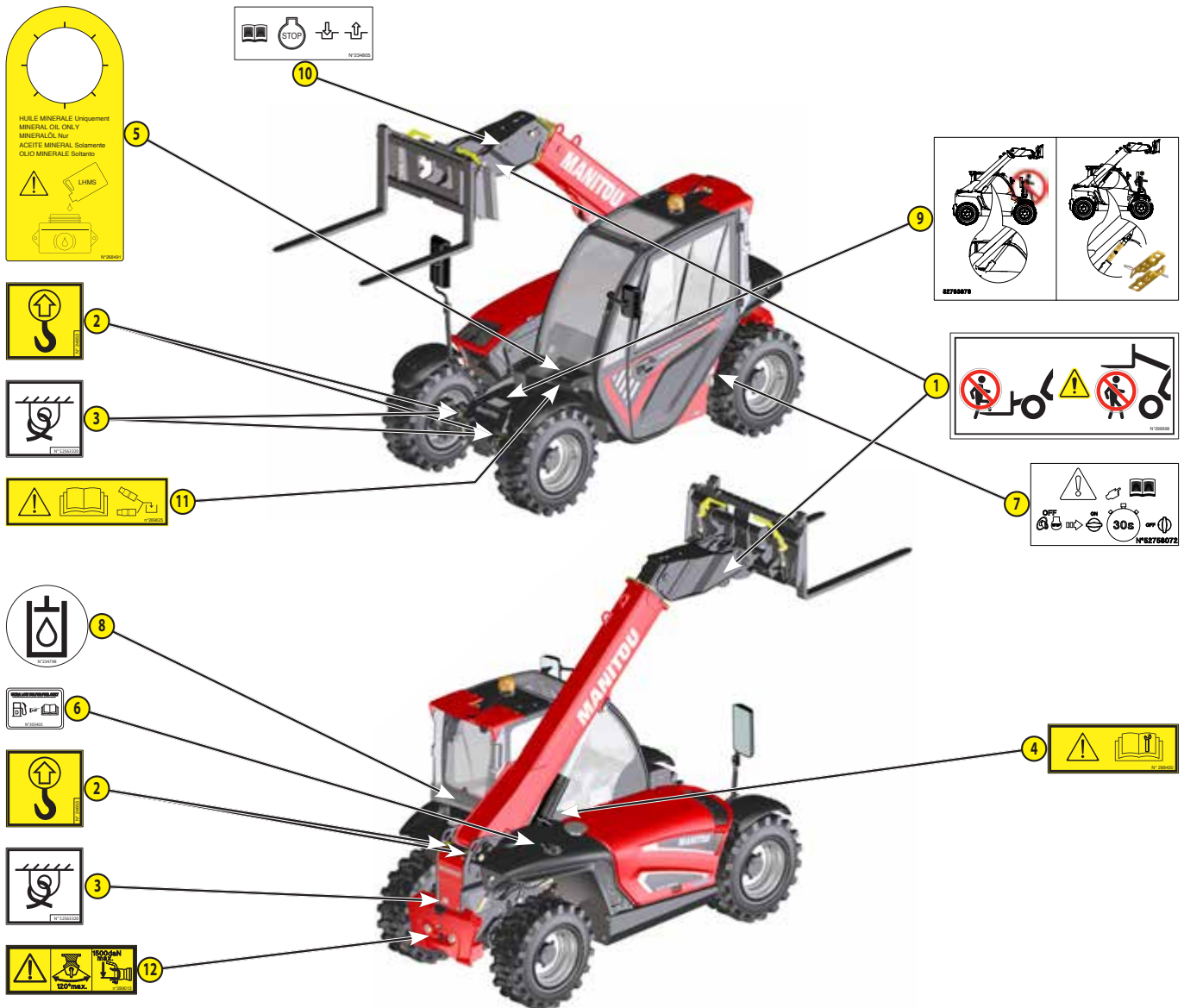

STICKERS AND PLATES UNDER THE ENGINE HOOD

ITEM	REFERENCE	DESCRIPTION
1	259398	-Water/diesel separator
2	293887	-Anti-freeze
3	52621201	-Caution - Hot surface
4	52562266	-Travel repair
5	52552722	-Air conditioning (OPTION)
6	233088	-Preheat rod (OPTION)
7	52621210	-Danger - Rotating blades

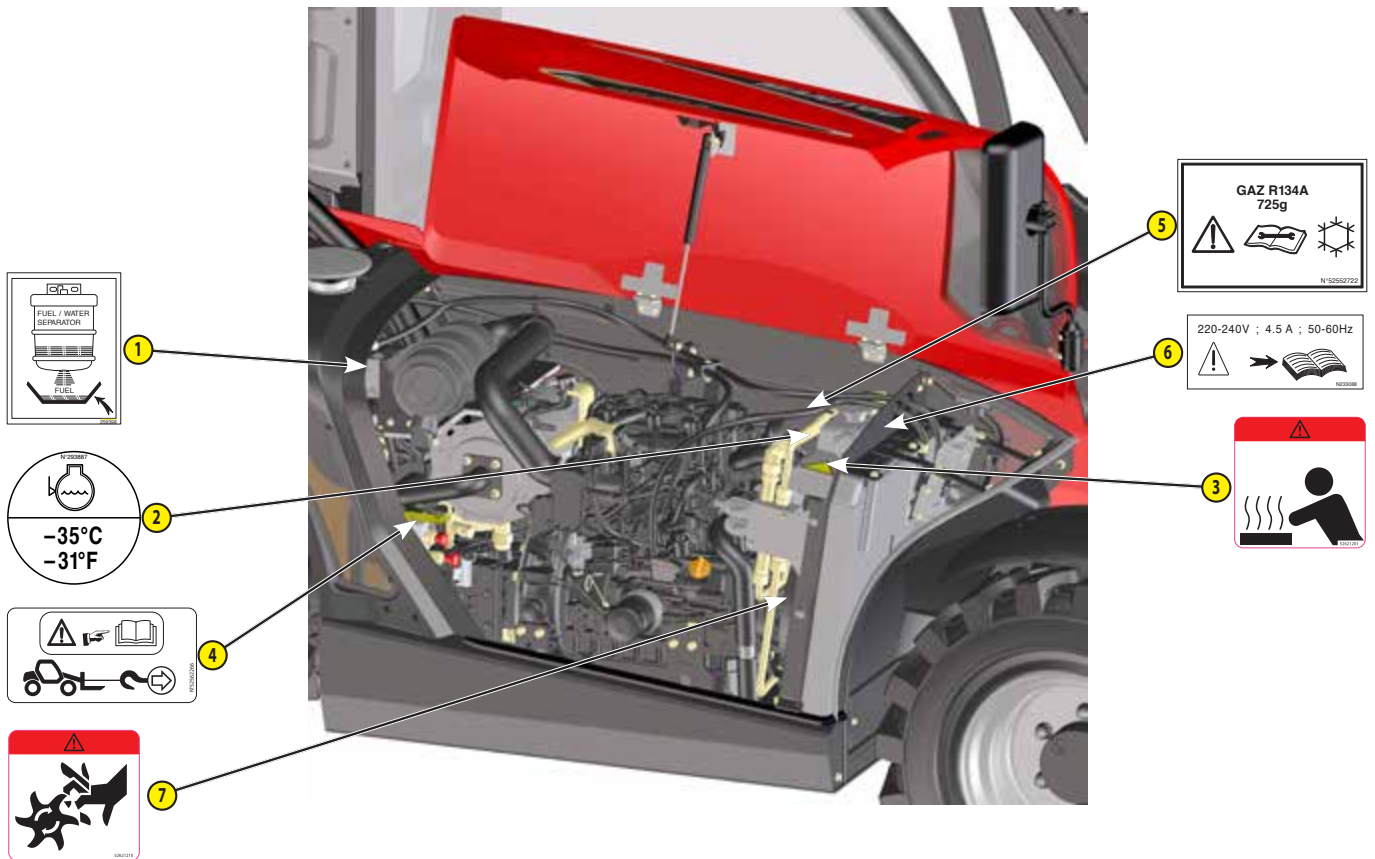

PLATES AND STICKERS IN THE CAB

ITEM	REFERENCE	DESCRIPTION
1	240805	- Cover load chart
2	241621	- Safety instruction
3	52509004	- Joystick function (closed cab)
	52665825	- Joystick function (opened cab)
4	52746584	- Tyres
5	52745955	- Fuses and relays
6	52746127	- Fuses and relays
7	52745924	- Lubrication
8	52745818	- Consumption sheet
9	239594	- Sound power level
10	52553499	- Operating mode management instruction
11	52651762	- Hydraulic controls activation
12	52655274	- "Stationary machine" exhaust regeneration
13	184276	- Steering selection
14	52580160	- Towing prohibited
15	290183	- Bucket instruction on telescope
16	52708563	- Hydraulic attachment locking function (OPTION)
17	52708709	- Boom head electrovalve function (OPTION)
18	52796858	- Pick & Carry (ULM 412 H 36Y ST5 S1)
	52796877	- Pick & Carry (ULM 415 H 36Y ST5 S1)
19	52673404	- Static steady
	52673414	- Static steady
20	265284	- Lifting ring on single carriage
21	52761547	- Fuses and relays

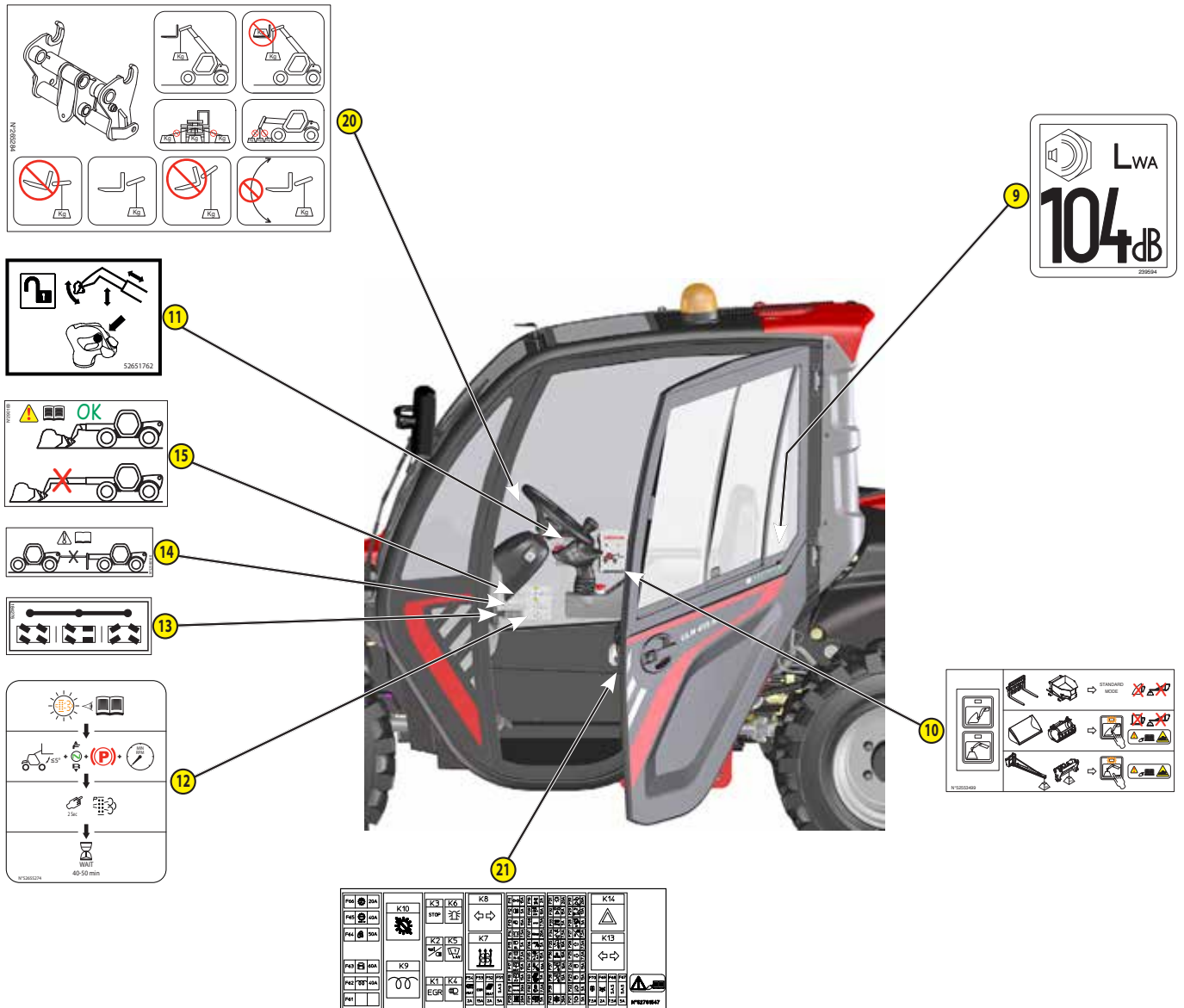

MACHINE IDENTIFICATION

As our policy is to promote constant improvement of our products, our range of machines may undergo certain modifications, without obligation for us to advise our customers.

When you order parts, or when you require any technical information, always specify:

NOTE: In order to have all these numbers on hand when needed, it is recommended that they are noted in the spaces provided, at the time of the delivery of the machine.

For any further technical information regarding your machine refer to chapter: SPECIFICATIONS.

MACHINE MANUFACTURER'S PLATE

"Designation" Designation	
"Series" Standard	
"Year of manufacture" Year of manufacture	
"Serial Number / Product Identification Number" Serial number / Product Identification Number	
"Model year" Model year	
"Unladen mass" Unladen weight	
"Power" Power	
"Authorized gross vehicle weight" Authorized gross vehicle weight	
"Rated capacity" Rated capacity	
"Max vertical force (on trailer hook)" Maximum vertical force (on trailer hook)	
"Drag strain" Pulling force	
"Shipping mass" Shipping mass	



ENGINE

"MODEL" Model	
"DISPLACEMENT" Displacement	
"ENGINE N°" Engine number	

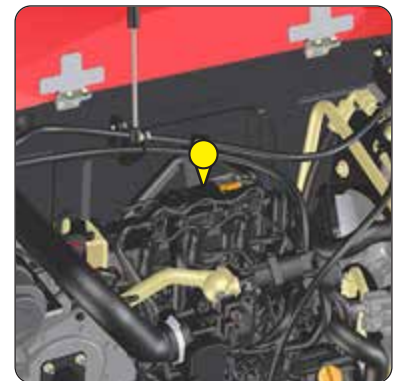

HYDROSTATIC PUMP

"MADE IN (COUNTRY OF ORIGIN)" Made in (country of origin)	
"Material No." Material number	
"Model Code" Model code	
"Serial No." Serial Number	



HYDROSTATIC MOTOR

"MADE IN (COUNTRY OF ORIGIN)" Made in (country of origin)	
"Material No." Material number	
"Model Code" Model code	
"Serial No." Serial Number	

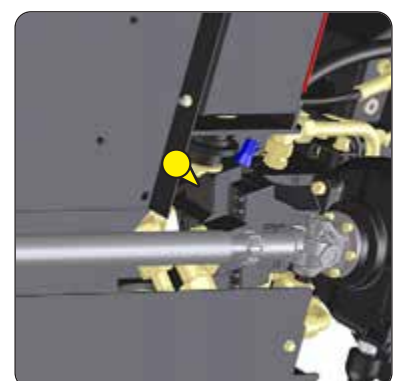

FRONT AXLE

"AXLE TYPE" Axle type	
"SERIAL N." Serial Number	
"CARRARO N." CARRARO No.	
"CUSTOMER N." MANITOU reference	



REAR AXLE

"AXLE TYPE" Axle type	
"SERIAL N." Serial Number	
"CARRARO N." CARRARO No.	
"CUSTOMER N." MANITOU reference	

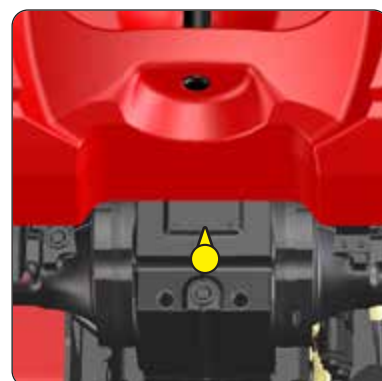

TRANSFER BOX

"SERIAL NO." Serial Number	
"REF. NO." CARRARO No.	

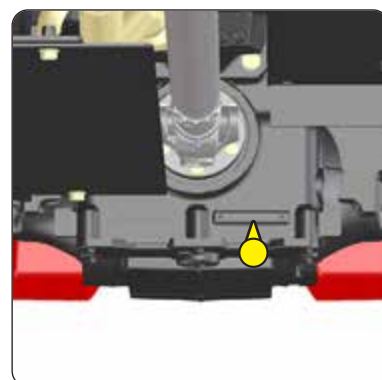

CAB

"Constructeur" Manufacturer	
"Type Cabine" Cab Type	
"Numéro de série" Serial Number	

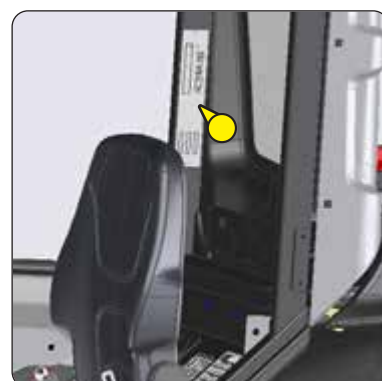

BOOM

MANITOU reference	
Date of manufacture and manufacturer	

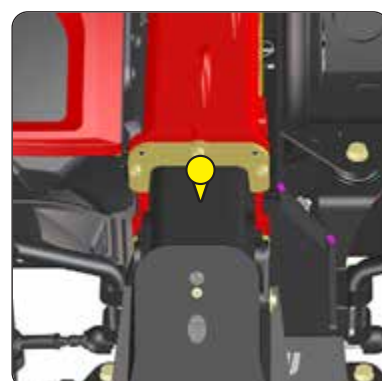

CHASSIS

Serial number / Product Identification Number	
---	--



ATTACHMENT MANUFACTURER'S PLATE

"MODELE" Model	
"N° série" Serial Number	
"Année Fabrication" Year of manufacture	
"Masse à vide" Unladen weight	
"Centre de gravité" Center of gravity	
"Capacité Nominale" Rated capacity	
"Pression service" Working pressure	

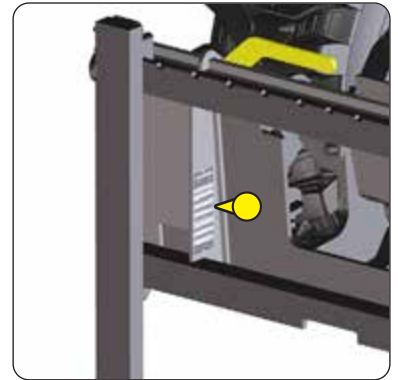

ENGINE		
Type		YANMAR 3TNV88C-DMU
Fuel		Diesel
Number of cylinders		3 in line
Suction		Supercharged
Injection system		Direct
Ignition sequence		-
Displacement	cm ³	1642
Bore and stroke	mm	88 x 90
Compression ratio		
Nominal speed laden	rpm	3000
Min. rpm unladen	rpm	950
Max. rpm unladen	rpm	3150
Power ISO 3046-1	hp - kW	36,7 - 27,5
Power SAE J 1995	hp - kW	36,7 - 27,5
Maximum torque ISO 14396	Nm	105 at 1,950 rpm
Air filtration efficiency	%	99,9
Type of cooling		Coolant
Fan		Suction

TRANSMISSION		
Hydrostatic pump		DANFOSS
- Type		Variable displacement piston motor
- Forward/reverse selector		Electro-hydraulics
- Number of forward speeds		2 (1 slow and 1 fast)
- Number of reverse speeds		2 (1 slow and 1 fast)
Main pump		
- MAX - MIN. displacement	cm ³ /rev	0 - 28
- MAX. flow rate	ℓ/min	88,2
- Working pressure	bar	350
Booster pump		
- Displacement	cm ³ /rev	12
- MAX. flow rate	ℓ/min	37,8
- Boost pressure MAX. speed	bar	24 (transmission in neutral)
Hydrostatic motor		DANFOSS
- Type		variable bi-directional
- MAX - MIN. displacement	cm ³ /rev	20 - 60
Transfer box		CARRARO
Front axle		CARRARO
- Differential		45% limited slip differential
Rear axle		CARRARO
- Differential		45% limited slip differential
Drive wheels		Permanent 4 WD
- 2/4 wheel drive control		no
Front tires		CAMSO
- Size		10.0 75-15.3 MPT
- Pressure	bar	7,1
Rear tires		CAMSO
- Size		10.0 75-15.3 MPT
- Pressure	bar	7,1

ELECTRIC CIRCUIT		
Battery		12 V - 110 Ah - 750 A EN
Alternator		12 V - 55 A
- Type		-
Starter		12 V - 1,4 KW
- Type		-

SOUND AND VIBRATION		
Sound pressure level in the driver's cab LpA (according to standard EN 12053)	dB(A)	76 (cab closed)
Sound pressure (according to Directive 2009/76)	dB(A)	-
Guaranteed sound power level in the environment LwA (according to Directive 2000/14/EC modified by Directive 2005/88/EC)	dB(A)	104 (measured); 104 (guaranteed)
Sound level in motion (according to Directive 2009/63)	dB(A)	-
Average weighted acceleration on driver's body (according to standard EN 13059)	m/s ²	-
The average weighted acceleration transmitted to the driver's hand/arm system (according to standard ISO 5349-2)	m/s ²	< 2,5
Standard seat vibration	m/s ²	-

BRAKE SYSTEM	
Service brake	Hydraulic power brake
- Type of brake	Disc brake on front axle output
- Type of order	By foot on front axle
Parking brake	Low pressure hydraulic brake
- Type of brake	Disc brake on front axle output
- Type of order	Switch-operated electro-hydraulic

HYDRAULIC CIRCUIT			
Hydraulic pump			
- Type		With gears	
		STANDARD	OPTION HIGH FLOW
- Displacement	cm ³	14	19
- Max. rating capacity unladen	ℓ/min	48	62
- Flow at 1600 rpm	ℓ/min	27	31
Filtration			
- Back	μm	10	
- Suction	μm	135	
Maximum working pressure		235	
- Telescoping circuit	bar	180 / 235	
- Lift circuit	bar	235 / 235	
- Tilt circuit	bar	235 / 235	
- Attachment circuit (OPTION)	bar	235	
- Steering circuit	bar	140	

HYDRAULIC MOVEMENTS		
Longitudinal stability limiter and warning device		Electronics
Lifting motions (boom retracted)		
- Unladen lifting	s - m/min	8.8
- Laden lifting	s - m/min	8.8
- Unladen lowering	s - m/min	7
- Laden lowering	s - m/min	7
Telescoping motions (boom raised)		
- Unladen extending	s - m/min	6.4
- Laden extending	s - m/min	6.4
- Unladen retracting	s - m/min	4.3
- Laden retracting	s - m/min	4.3
Tilting movements		
- Unladen digging	s - °/s	3.4
- Unladen dump	s - °/s	2.6

SPECIFICATIONS AND WEIGHTS			
Speed of movement for machine in standard configuration on flat ground			
• Front unladen	• 1 Slow	km/h	8
	• 1 fast	km/h	25
• Rear unladen	• 1 Slow	km/h	8
	• 1 fast	km/h	25
Standard attachment		CAT 1020/1500 F75X35X1100	
- Weight of attachment (without forks)		kg	155
- Weight of forks (each)		kg	31,5
Rated capacity with standard attachment		kg	1250
Tipping load at maximum reach on tires		kg	-
Distance from the center of gravity of the load to the base of the forks		mm	500
Standard lifting height		mm	4300
Weight of machine without attachment		kg	2625
Standard transportable weight of the machine		2550 (without options) 2750 (with options)	
Weight of machine with standard attachment			
- Unladen		kg	2800 (without options) 2950 (with options)
- At rated load		kg	4090
Weight per axle with standard attachment (transport position)			
- Front unladen		kg	1370
- Rear unladen		kg	1470
- Front rated load		kg	3560
- Rear rated load		kg	530
Weight per axle with standard attachment (boom extended)			
- Front rated load		kg	3840
- Rear rated load		kg	250
Tractive effort on the coupling hook			
- Unladen (sliding)		daN	1850
- At rated load (transmission setting)		daN	2000
Break-out force with bucket (according to standard ISO 8313)		daN	1880

ENGINE		
Type		YANMAR 3TNV88C-DMU
Fuel		Diesel
Number of cylinders		3 in line
Suction		Supercharged
Injection system		Direct
Ignition sequence		-
Displacement	cm ³	1642
Bore and stroke	mm	88 x 90
Compression ratio		
Nominal speed laden	rpm	3000
Min. rpm unladen	rpm	950
Max. rpm unladen	rpm	3150
Power ISO 3046-1	hp - kW	36,7 - 27,5
Power SAE J 1995	hp - kW	36,7 - 27,5
Maximum torque ISO 14396	Nm	105 at 1,950 rpm
Air filtration efficiency	%	99,9
Type of cooling		Coolant
Fan		Suction

TRANSMISSION		
Hydrostatic pump		DANFOSS
- Type		Variable displacement piston motor
- Forward/reverse selector		Electro-hydraulics
- Number of forward speeds		2 (1 slow and 1 fast)
- Number of reverse speeds		2 (1 slow and 1 fast)
Main pump		
- MAX - MIN. displacement	cm ³ /rev	0 - 28
- MAX. flow rate	ℓ/min	88,2
- Working pressure	bar	350
Booster pump		
- Displacement	cm ³ /rev	12
- MAX. flow rate	ℓ/min	37,8
- Boost pressure MAX. speed	bar	24 (transmission in neutral)
Hydrostatic motor		DANFOSS
- Type		variable bi-directional
- MAX - MIN. displacement	cm ³ /rev	20 - 60
Transfer box		CARRARO
Front axle		CARRARO
- Differential		45% limited slip differential
Rear axle		CARRARO
- Differential		45% limited slip differential
Drive wheels		Permanent 4 WD
- 2/4 wheel drive control		no
Front tires		CAMSO
- Size		10.0 75-15.3 MPT
- Pressure	bar	7,1
Rear tires		CAMSO
- Size		10.0 75-15.3 MPT
- Pressure	bar	7,1

ELECTRIC CIRCUIT		
Battery		12 V - 110 Ah - 750 A EN
Alternator		12 V - 55 A
- Type		-
Starter		12 V - 1,4 KW
- Type		-

SOUND AND VIBRATION		
Sound pressure level in the driver's cab LpA (suivant norme EN 12053)	dB(A)	76 (cab closed)
Acoustic pressure (suivant directive 2009/76)	dB(A)	-
Guaranteed sound power level in the environment LwA (according to Directive 2000/14/EC modified by Directive 2005/88/EC)	dB(A)	104 (measured); 104 (guaranteed)
Sound level in motion (according to Directive 2009/63)	dB(A)	-
Average weighted acceleration on driver's body (in accordance with the standard EN 13059)	m/s ²	-
The average weighted acceleration transmitted to the driver's hand/arm system (according to standard ISO 5349-2)	m/s ²	< 2,5
Standard seat vibration	m/s ²	-

BRAKE SYSTEM	
Service brake	Hydraulic power brake
- Type of brake	Disc brake on front axle output
- Type of order	By foot on front axle
Parking brake	Low pressure hydraulic brake
- Type of brake	Disc brake on front axle output
- Type of order	Switch-operated electro-hydraulic

HYDRAULIC CIRCUIT			
Hydraulic pump			
- Type		With gears	
		STANDARD	OPTION HIGH FLOW
- Displacement	cm ³	14	19
- Max. rating capacity unladen	ℓ/min	48	62
- Flow at 1600 rpm	ℓ/min	27	31
Filtration			
- Back	μm	10	
- Suction	μm	135	
Maximum working pressure		235	
- Telescoping circuit	bar	180 / 235	
- Lift circuit	bar	235 / 235	
- Tilt circuit	bar	235 / 235	
- Attachment circuit (OPTION)	bar	235	
- Steering circuit	bar	140	

HYDRAULIC MOVEMENTS		
Longitudinal stability limiter and warning device		Electronics
Lifting motions (boom retracted)		
- Unladen lifting	s - m/min	8.8
- Laden lifting	s - m/min	8.8
- Unladen lowering	s - m/min	7
- Laden lowering	s - m/min	7
Telescoping motions (boom raised)		
- Unladen extending	s - m/min	6.4
- Laden extending	s - m/min	6.4
- Unladen retracting	s - m/min	4.3
- Laden retracting	s - m/min	4.3
Tilting movements		
- Unladen digging	s - °/s	3.4
- Unladen dump	s - °/s	2.6

SPECIFICATIONS AND WEIGHTS			
Speed of movement for machine in standard configuration on flat ground			
• Front unladen	• 1 Slow	km/h	8
	• 1 fast	km/h	25
• Rear unladen	• 1 Slow	km/h	8
	• 1 fast	km/h	25
Standard attachment		CAT 1020/1500 F75X35X1100	
- Weight of attachment (without forks)	kg	155	
- Weight of forks (each)	kg	31,5	
Rated capacity with standard attachment	kg	1450	
Tipping load at maximum reach on tires	kg	-	
Distance from the center of gravity of the load to the base of the forks	mm	500	
Standard lifting height	mm	4300	
Weight of machine without attachment	kg	2805	
Standard transportable weight of the machine		2550 (without options) 2900 (with options)	
Weight of machine with standard attachment			
- Unladen	kg	2950 (without options) 3100 (with options)	
- At rated load	kg	4470	
Weight per axle with standard attachment (transport position)			
- Front unladen	kg	1390	
- Rear unladen	kg	1630	
- Front rated load	kg	3890	
- Rear rated load	kg	580	
Weight per axle with standard attachment (boom extended)			
- Front rated load	kg	4200	
- Rear rated load	kg	270	
Tractive effort on the coupling hook			
- Unladen (sliding)	daN	1850	
- At rated load (transmission setting)	daN	2000	
Break-out force with bucket (according to standard ISO 8313)	daN	1880	

TIRES

		(bar)	LOAD PER TIRE (kg)			
			FRONT UNLADEN	FRONT (LADEN)	REAR (UNLADEN)	REAR (LADEN)
ALLIANCE	305/70 R16.5 A550	4	695	1945	815	290
CAMSO	12-16.5 12PR SKS 732	5,6				
	10.0/75-15.3 MPT 552	5,6				
MICHELIN	300/70 R16.5 137A8/137B IND TL BIBSTEEL HARD SURFACE	4,8				
	300/70 R16.5 137A8/137B IND TL BIBSTEEL ALL TERRAIN	4,8				
MITAS	31X15.5-15 8PR TR-07 121/109 A8 TL	3				
TRELLEBORG	11LR16 TL 122A8 IND TH400	3,6				

		PRESSURE (bar)	LOAD (kg)	PRESSURE ON THE CONTACT SURFACE (kg/cm ²)		GROUND CONTACT AREA (cm ²)	
				HARD GROUND	SOFT GROUND	HARD GROUND	SOFT GROUND
ALLIANCE	305/70 R16.5 A550	4	290	4,46			
			695	5,54			
			815	5,75			
			1945	6,52			
CAMSO	12-16.5 12PR SKS 732	5,6	290		1,6		
			695		2,3		
			815		2,4		
			1945		3,6		
	10.0/75-15.3 MPT 552	5,6	290		/		
			695		4,6		
			815		4,6		
			1945		4,9		
MICHELIN	300/70 R16.5 137A8/137B IND TL BIBSTEEL HARD SURFACE	4,8	290		/		
			695		/		
			815		/		
			1945		5		
	300/70 R16.5 137A8/137B IND TL BIBSTEEL ALL TERRAIN	4,8	290		/		
			695		/		
			815		/		
			1945		4		
MITAS	31X15.5-15 8PR TR-07 121/109 A8 TL	3	290	5,1	1,4	57	210
			695	7	1,6	100	426
			815	7,3	1,7	111	484
			1945	9,6	2,3	202	856
TRELLEBORG	11LR16 TL 122A8 IND TH400	3,6	290	4,5	1,1	65	274
			695	6,9	1,6	100	436
			815	7,5	1,7	108	466
			1945	11,2	2,6	174	739

DIMENSIONS

ULM 412 H 36Y ST5 S1 "ESSENTIAL"
 ULM 415 H 36Y ST5 S1 "ESSENTIAL"

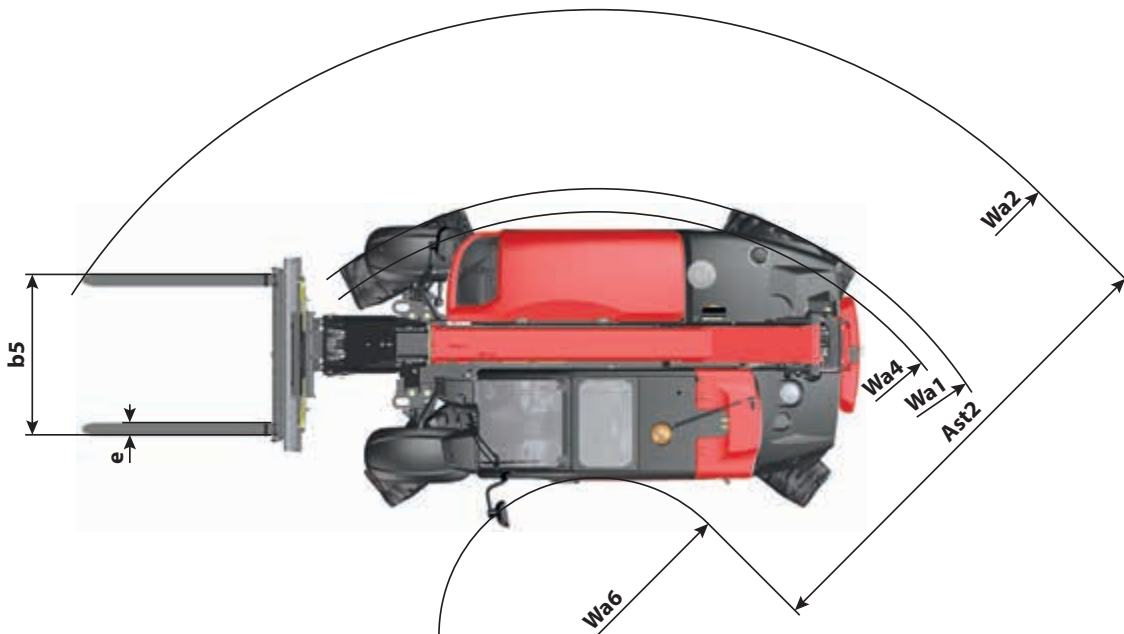
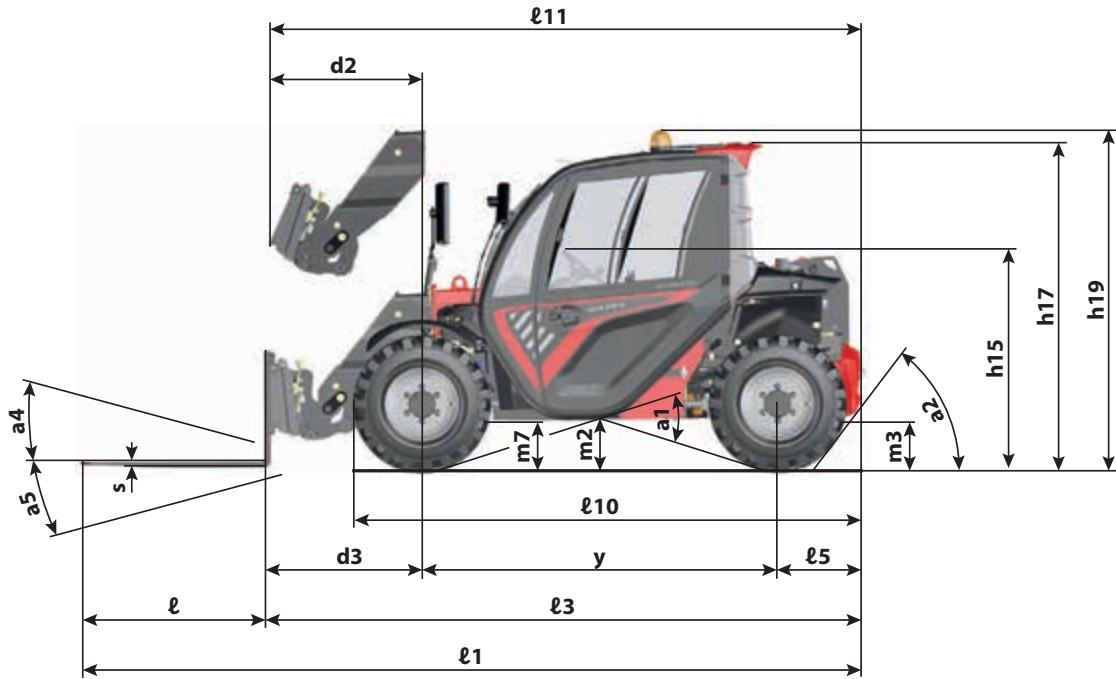

MACHINE LENGTH	ℓ1	mm	4560
	ℓ3	mm	3360
	ℓ5	mm	465
	ℓ10	mm	3005
	ℓ11	mm	3300
MACHINE WIDTH	b1	mm	1490
	b4	mm	655
	b5	mm	1015
	b9	mm	1160
	b10	mm	1160
MACHINE HEIGHT	h15	mm	1310
	h17	mm	1890
	h19	mm	2005
DISTANCE	d2	mm	710
	d3	mm	770
AISLE WIDTH	Ast2	mm	2850
ATTACHMENT	ℓ	mm	1200
	e	mm	100
	s	mm	40
TURNING RADIUS	Wa1	mm	2620
	Wa2	mm	3730
	Wa4	mm	2450
	Wa6	mm	870
GROUND CLEARANCE	m2	mm	265
	m3	mm	245
	m7	mm	245
ANGLE	a1	°	35
	a2	°	52
	a4	°	23
	a5	°	116
WHEELBASE	y	mm	2130

DIMENSIONS

ULM 412 H 36Y ST5 S1 "COMFORT"
 ULM 415 H 36Y ST5 S1 "COMFORT"

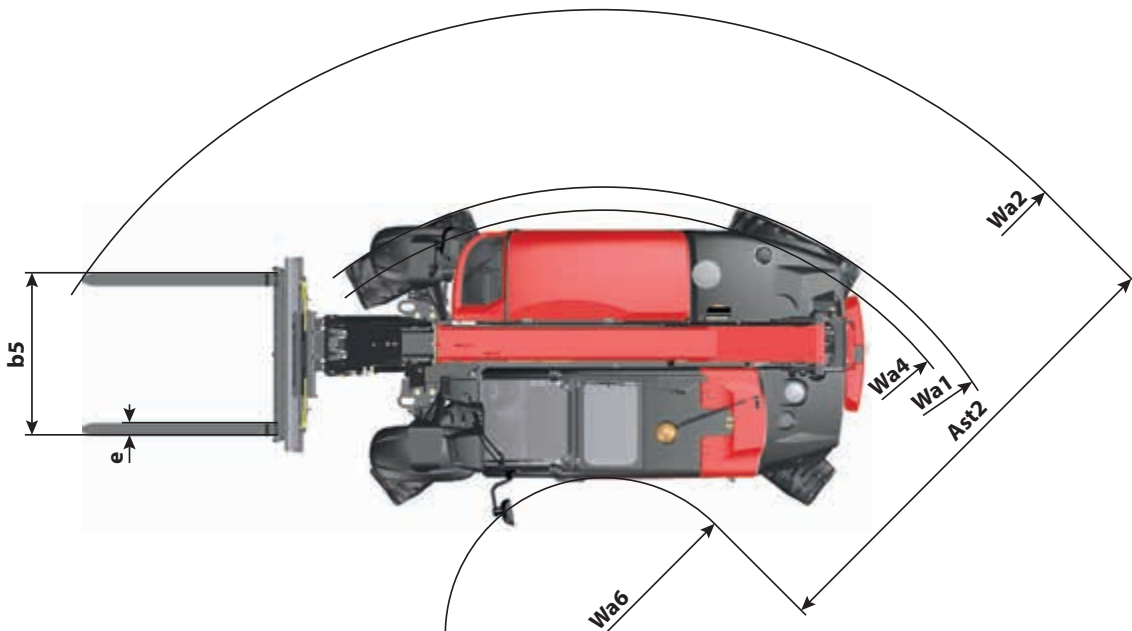
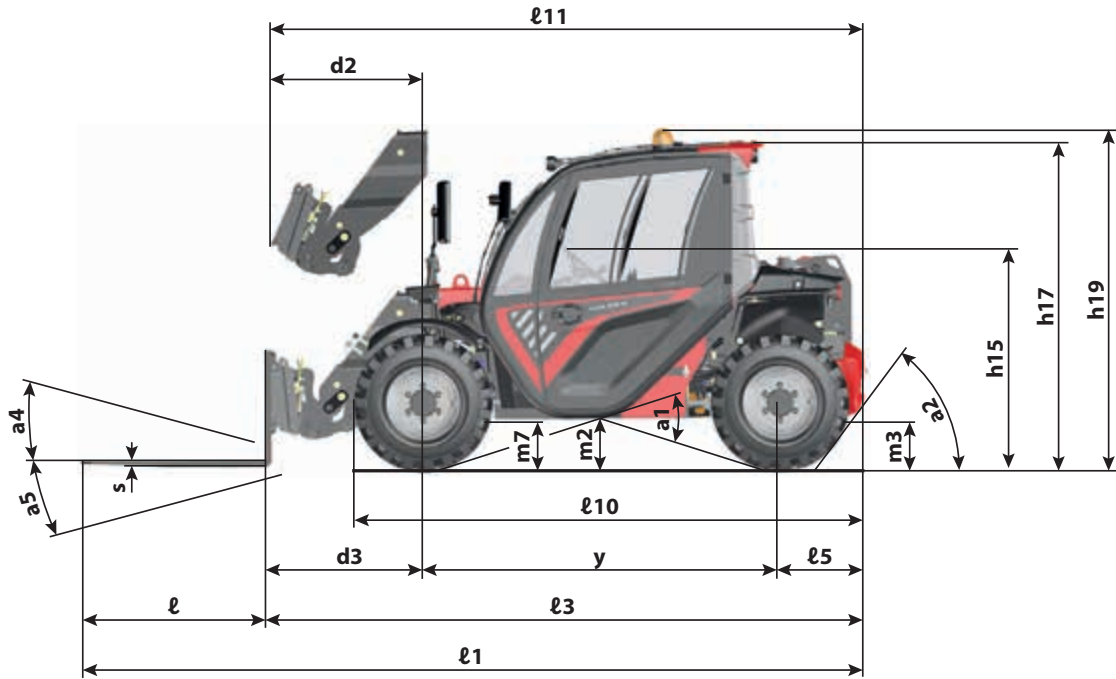

MACHINE LENGTH	ℓ1	mm	4560
	ℓ3	mm	3360
	ℓ5	mm	465
	ℓ10	mm	3005
	ℓ11	mm	3300
MACHINE WIDTH	b1	mm	1490
	b4	mm	655
	b5	mm	1015
	b9	mm	1160
	b10	mm	1160
MACHINE HEIGHT	h15	mm	1310
	h17	mm	1890
	h19	mm	2005
DISTANCE	d2	mm	710
	d3	mm	770
AISLE WIDTH	Ast2	mm	2850
ATTACHMENT	ℓ	mm	1200
	e	mm	100
	s	mm	40
TURNING RADIUS	Wa1	mm	2620
	Wa2	mm	3730
	Wa4	mm	2450
	Wa6	mm	870
GROUND CLEARANCE	m2	mm	265
	m3	mm	245
	m7	mm	245
ANGLE	a1	°	35
	a2	°	52
	a4	°	23
	a5	°	116
WHEELBASE	y	mm	2130

DIMENSIONS

ULM 412 H 36Y ST5 S1 "CLASSIC"
 ULM 415 H 36Y ST5 S1 "CLASSIC"

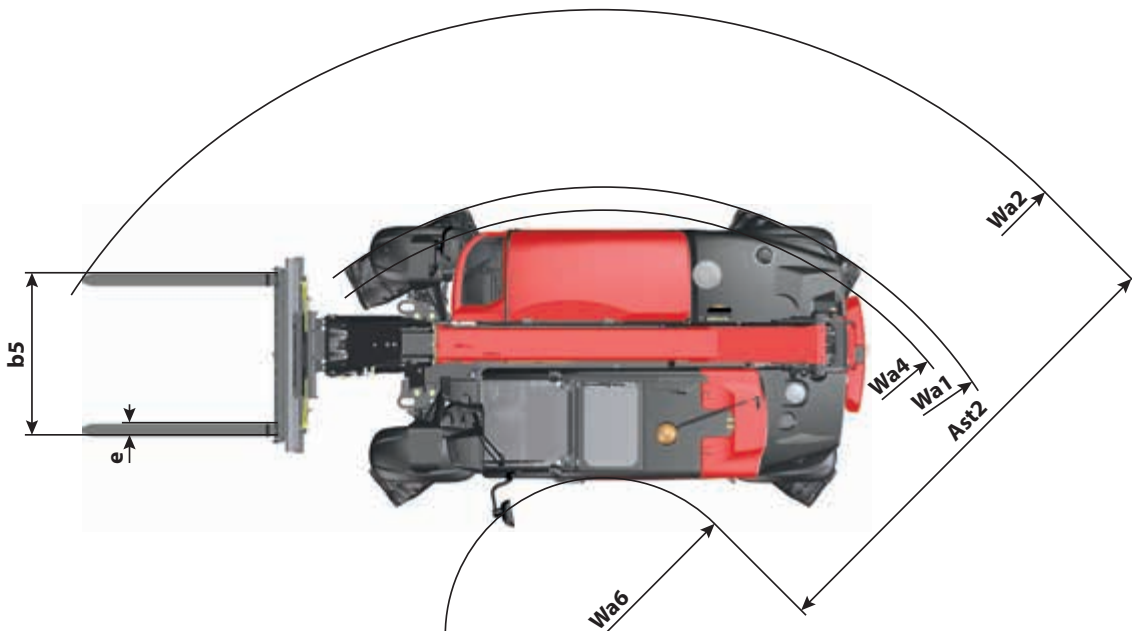
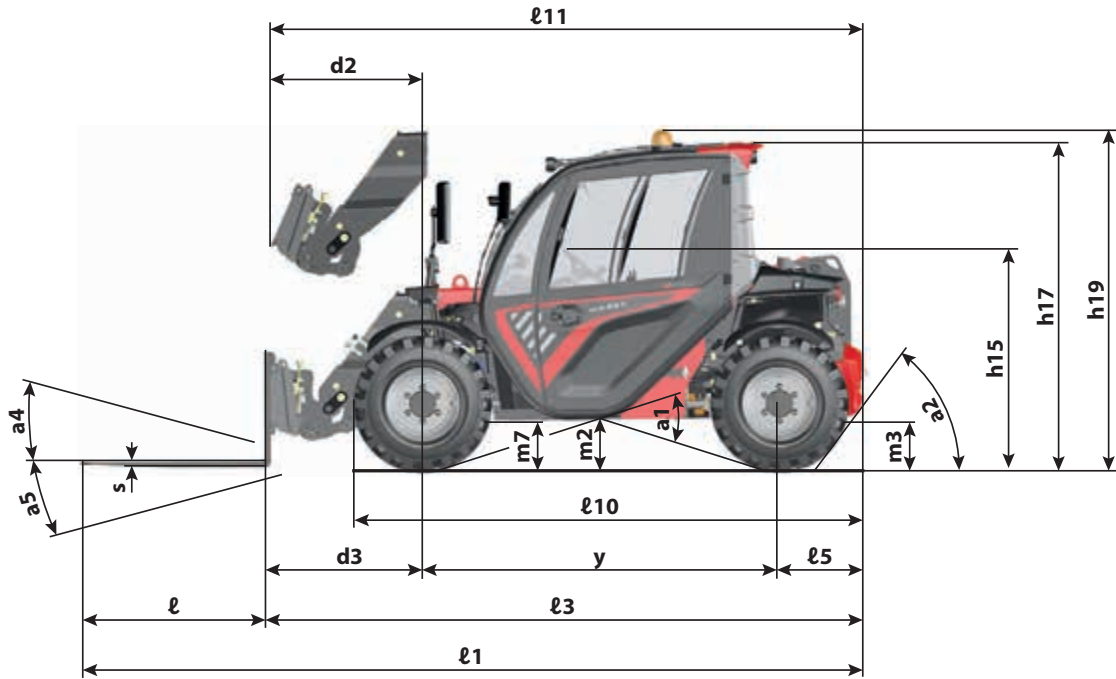

MACHINE LENGTH	ℓ1	mm	4560
	ℓ3	mm	3360
	ℓ5	mm	465
	ℓ10	mm	3005
	ℓ11	mm	3300
MACHINE WIDTH	b1	mm	1490
	b4	mm	655
	b5	mm	1015
	b9	mm	1160
	b10	mm	1160
MACHINE HEIGHT	h15	mm	1310
	h17	mm	1890
	h19	mm	2005
DISTANCE	d2	mm	710
	d3	mm	770
AISLE WIDTH	Ast2	mm	2850
ATTACHMENT	ℓ	mm	1200
	e	mm	100
	s	mm	40
TURNING RADIUS	Wa1	mm	2620
	Wa2	mm	3730
	Wa4	mm	2450
	Wa6	mm	870
GROUND CLEARANCE	m2	mm	265
	m3	mm	245
	m7	mm	245
ANGLE	a1	°	35
	a2	°	52
	a4	°	23
	a5	°	116
WHEELBASE	y	mm	2130

STANDARD WITH TIRES "A"

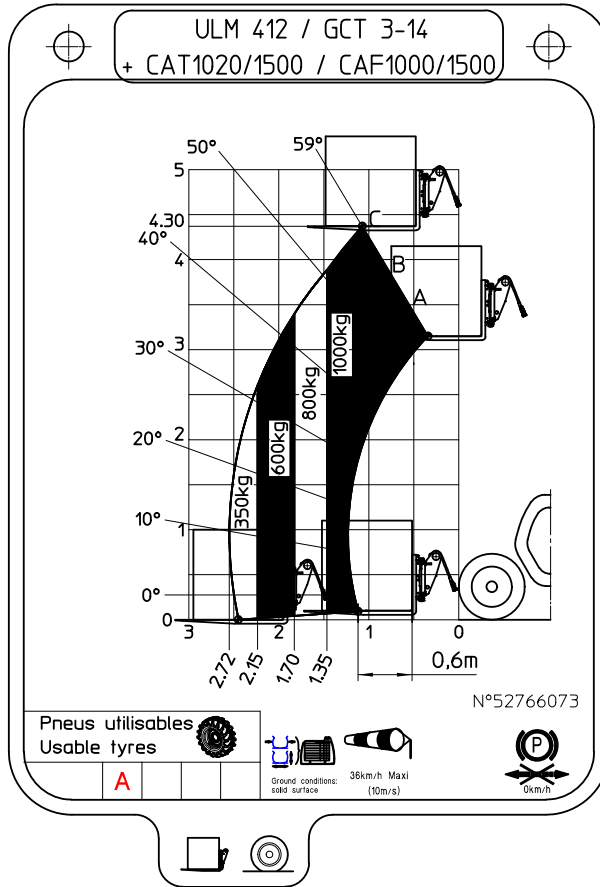

LIFTING RING ON SINGLE CARRIAGE (OPTION)

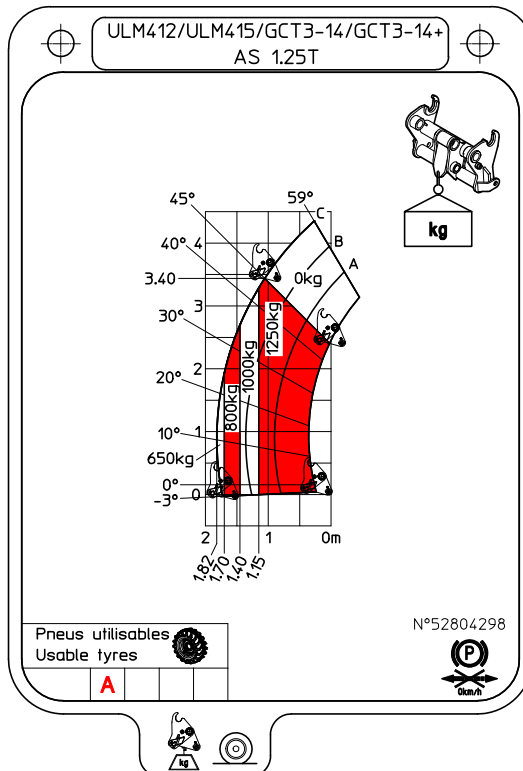

STANDARD WITH TIRES "A"

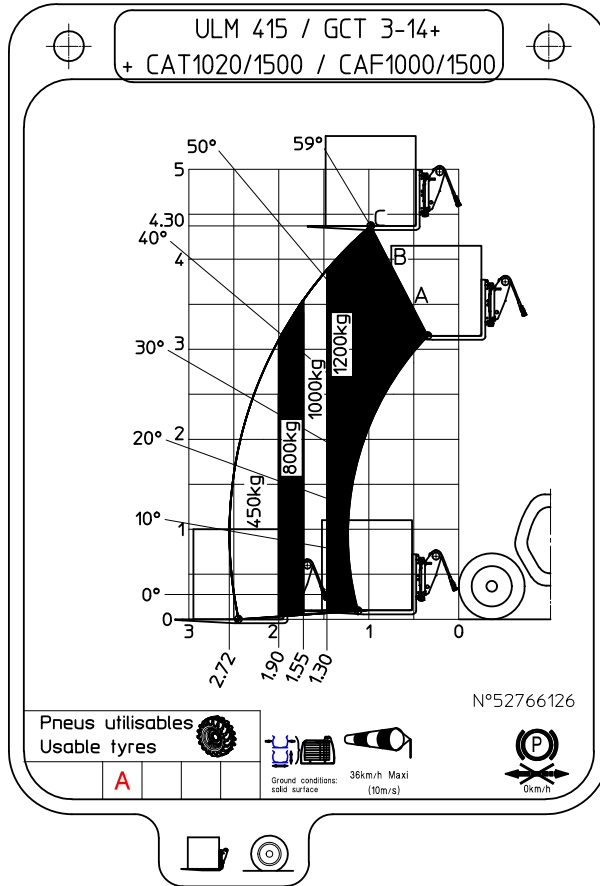

LIFTING RING ON SINGLE CARRIAGE (OPTION)

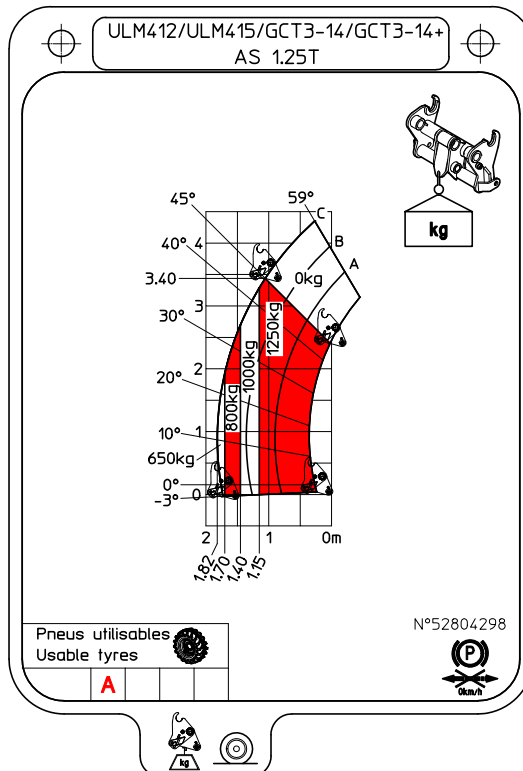

VISIBILITY

We use European standard EN15830 relating to operator visibility.

- Adhere to the instructions for optimizing operator visibility in the immediate vicinity (≤ 1 - OPERATING AND SAFETY INSTRUCTIONS: OPERATOR INSTRUCTIONS: OPERATING INSTRUCTIONS WITH AND WITHOUT LOAD: D - VISIBILITY).

DESCRIPTION AND ADJUSTMENT OF REAR-VIEW MIRRORS

- 1 - LEFT REAR-VIEW MIRROR
- 2 - RIGHT SIDE REAR-VIEW MIRROR
- 3 - INSIDE REAR-VIEW MIRROR (OPTION)

- Place the machine on level ground with the engine stopped, and the boom retracted and lowered as far as possible.
- Note the position of the reference points ●...○ in the illustrations, to see and correctly adjust the rear-view mirrors.

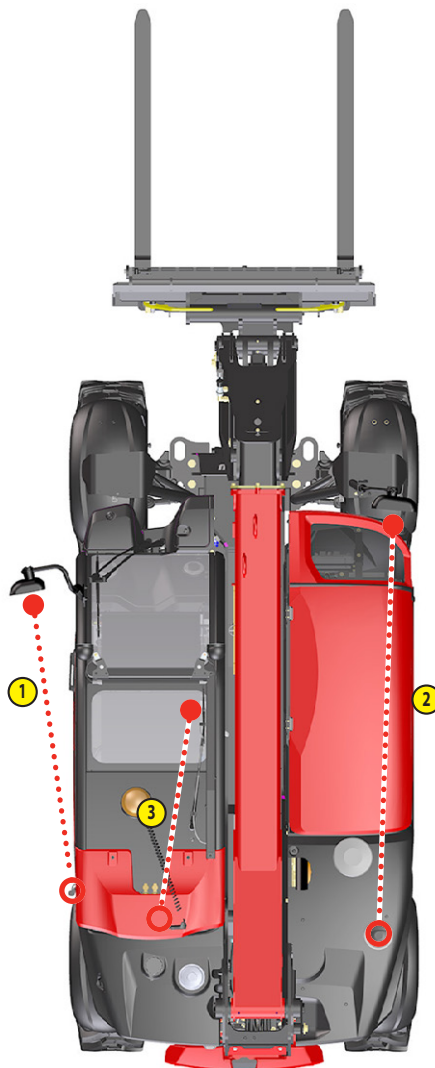
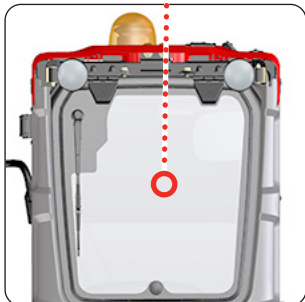
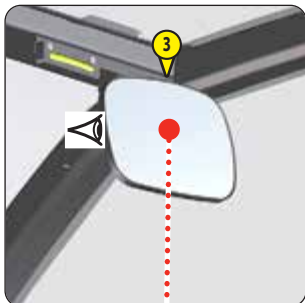
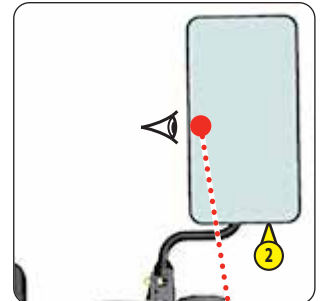
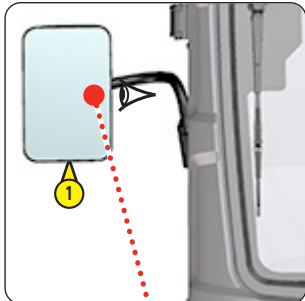

INSTRUMENTS AND CONTROLS

DESCRIPTION

NOTE: All the terms such as: RIGHT, LEFT, FRONT, REAR are as seen by an observer occupying the driver's seat and looking straight ahead.

1 - DRIVER'S CAB ACCESS	2-32
2 - DRIVER'S SEAT	2-32
3 - ARMREST AND STORAGE	2-33
4 - SEAT BELT	2-33
5 - BATTERY CUT-OFF	2-33
6 - EMERGENCY STOP	2-33
7 - IGNITION SWITCH	2-33
8 - DASHBOARD "HARMONY"	2-34
9 - LONGITUDINAL STABILITY LIMITER AND WARNING DEVICE	2-38
10 - INFORMATION SCREEN CONTROL BUTTONS	2-40
11 - PUSH BUTTON PANEL	2-41
12 - SWITCHES	2-43
13 - DIAGNOSTIC PLUG	2-43
14 - USB RECHARGING SOCKET	2-43
15 - HORN BUTTON	2-43
16 - FRONT AND REAR WINDSHIELD WIPER SWITCH	2-44
17 - FUSES AND RELAYS	2-44
18 - FORWARD/NEUTRAL/REVERSE SELECTOR	2-46
19 - GEAR SELECTOR	2-46
20 - STEERING SELECTION	2-47
21 - ACCELERATOR PEDAL	2-47
22 - SERVICE BRAKE AND INCHING PEDAL "INCHING"	2-47
23 - FUNCTION FILES	2-48
24 - HYDRAULIC BOOM CONTROLS	2-48
25 - LEVEL INDICATORS	2-49
26 - HEATER CONTROL	2-49
27 - HEATING VENTS	2-49
28 - DOOR OPENING AND CLOSING HANDLES (CLOSED CAB)	2-49
29 - PRESSURE RELIEF VALVE	2-50
30 - SIDE WINDOWS OPENING AND CLOSING HANDLES (CLOSED CAB)	2-50
31 - REAR WINDOW STAY (CLOSED CAB)	2-50
32 - CAB STORAGE	2-50
33 - ROTATING BEACON LIGHT	2-50
34 - ROOF LIGHT	2-51
35 - BOOM SAFETY WEDGE	2-51
36 - FUEL TANK	2-51
37 - FLOOR EVACUATION	2-51

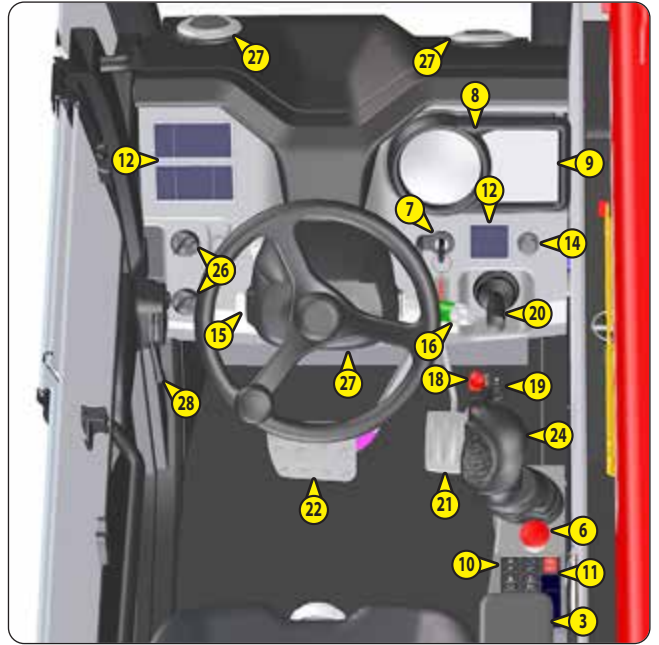
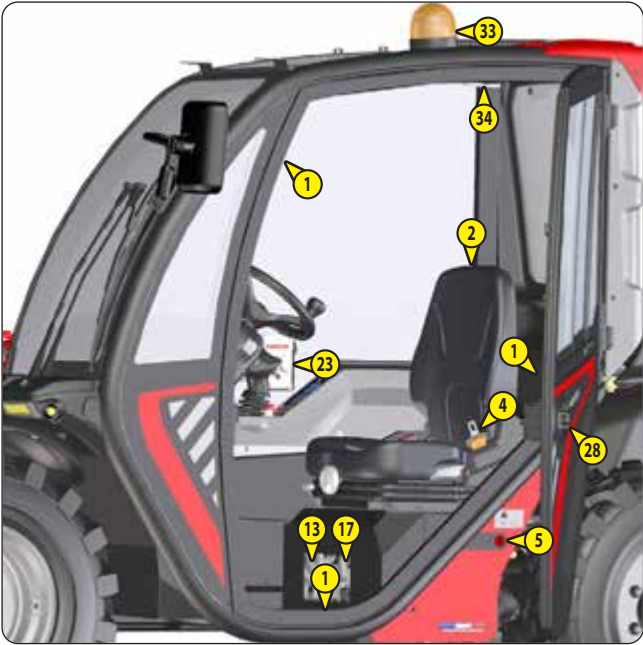

EMERGENCY BRAKE

SERVICE BRAKE

If the service brake is not working properly:

- Press down fully on the service brake pedal to immobilize the machine.
- Activate the hand-operated parking brake.



HAND-OPERATED PARKING BRAKE

⚠ IMPORTANT ⚠

Beware of sudden immobilization of the machine

In the event of immediate danger:

- Activate the hand-operated parking brake.



EMERGENCY EXIT

REAR WINDOW

Use the rear window as an emergency exit, in the event that it is impossible to leave the cab by the door or by opening the windshield.

- Remove the pin to fully open the rear window.



1 - DRIVER'S CAB ACCESS

Use the contact points 1 to get into or out of the driver's cab.

- Mounting at the front.
- Descending at the rear.



2 - DRIVER'S SEAT

For increased comfort, adjust the seat to your requirements and adopt the correct position in the driver's cab.

⚠ IMPORTANT ⚠

Under no circumstances must the seat be adjusted while the machine is moving.

MAINTENANCE

⚠ IMPORTANT ⚠

A moving backrest increases the risk of an accident!

Dirt may adversely affect the correct functioning of the seat. For this reason, make sure your seat is always clean.

- To clean or change the cushions, simply remove them from the seat frame.
- Avoid wetting the cushion fabric when cleaning it. First check the resistance of the fabric on a small concealed area before using any fabric and plastic cleaner.

WEIGHT ADJUSTMENT

- Sit on the seat.
- Turn button 1 to adjust according to the operator's weight.

BACKREST ANGLE ADJUSTMENT

⚠ IMPORTANT ⚠

If you do not support the backrest when making adjustments, it swings completely forward.

- Support the backrest, pull the lever 2 and tilt the backrest to the desired position.

LONGITUDINAL ADJUSTMENT

- Engage the locking lever 3 in the desired position.
- Once locked, you can no longer move the seat into another position.



3 - ARMREST AND STORAGE

- Lift the armrest 1 to access the storage or the radio.



4 - SEAT BELT

⚠ IMPORTANT ⚠

*Under no circumstances must the machine be used if the seat belt is defective (fixing, locking, cuts, tears, etc.).
Immediately repair or replace the seat belt.*

- Sit correctly on the seat.
- Check that the seat belt is not twisted.
- Place the seat belt at hip level.
- Attach the seat belt and check that it locks.
- Adjust the seat belt to your body shape without compressing your pelvis and without excessive slack.



5 - BATTERY CUT-OFF

Enables the battery to be quickly cut off when stopping use of the machine, as a preventive measure after parking, if work is being done on the electrical system or in an emergency to isolate a short-circuit.

⚠ IMPORTANT ⚠

Except in an emergency (fire, accident, overturning of the machine), never operate the battery cut-off with the engine running as this could damage the alternator and the machine's electronic components.

- Switch off the ignition with the key, wait 30 seconds, then operate the battery cut-off.

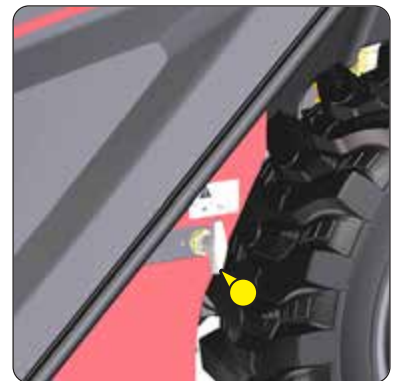

6 - EMERGENCY STOP

In the event of danger, it enables the engine to be shut down, thereby cutting-off all hydraulic movements.

⚠ IMPORTANT ⚠

*Be ready for hydraulic movements suddenly stopping when you press this button.
If possible stop the machine before using the emergency stop button.*

- Turn switch to disable.



7 - IGNITION SWITCH

This key switch has 5 positions:

- P - Not used.
- O - Ignition cut-off and engine stop.
- I - Ignition + preheat.
- II - Not used.
- III - Start-up and return to I position as soon as the key is released.



8 - DASHBOARD "HARMONY"

INSTRUMENTS AND INDICATORS

A - TACHOMETER

B - ENGINE WATER TEMPERATURE

If the indicator lamp  comes on when the machine is running, this means that the coolant temperature is high. Leave the engine idling to lower the water temperature. If the fault persists, turn the engine off and investigate the cooling circuit for the cause of the malfunction.

C - FUEL LEVEL

Indicator lamp , indicates that you are in reserve and that your running time is limited.

D - NOT USED



BATTERY LOAD FAULT INDICATOR

If the indicator and the buzzer come on when the machine is running, stop the engine immediately and determine the cause (electric circuit, alternator belt, alternator, etc.).



NOT USED



WATER IN FUEL PRE-FILTER FAULT INDICATOR

The indicator light will come on when water is detected in the fuel pre-filter. Stop the machine and carry out the necessary repairs.



BRAKING OIL LEVEL WARNING INDICATOR LAMP

If the indicator lamp and buzzer come on when the machine is running, stop the engine immediately and determine the cause (brake fluid level, possible leak, etc.). If the brake fluid level is abnormal, consult your dealer.



ENGINE OIL PRESSURE FAULT INDICATOR

If the indicator lamp comes on when the machine is in operation, stop the engine immediately and look for the cause (oil level in engine crankcase).

NOTE: After starting the engine, the indicator lamp remains on for a few seconds then goes out when the correct engine oil pressure is reached. The full engine power is then available.



NOT USED



NOT USED



NOT USED

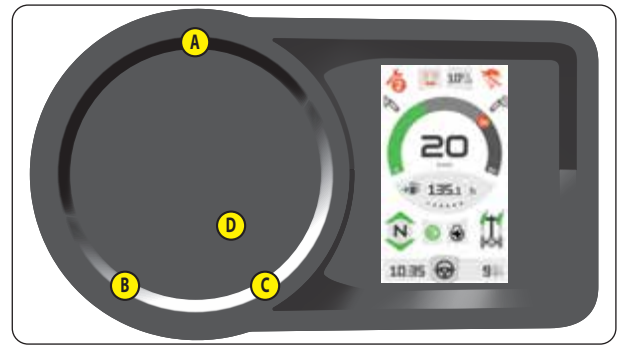



HYDRAULIC RETURN FILTER CLOGGING FAULT INDICATOR

The indicator light and buzzer come on when the hydraulic return oil filter cartridge is clogged. Stop the engine and carry out the necessary repairs (↖ 3 - MAINTENANCE: FILTER CARTRIDGES AND BELTS).



ENGINE COOLANT LEVEL FAULT INDICATOR

If the indicator light and buzzer come on when the machine is in operation, stop the engine immediately and determine the cause (coolant level, possible leak, radiator, etc.).



ENGINE STOPPED FAULT INDICATOR

If the indicator lights up or flashes when the machine is in operation, stop the engine immediately and consult your dealer.



NOT USED



ENGINE FAULT INDICATOR

If the indicator light comes on or flashes while the machine is in operation, a diagnostic fault has been detected. The machine will operate in reduced mode. Consult your dealer as soon as possible.



NOT USED



CRYSTALLIZATION OR SULFURIZATION LEVEL INDICATOR

If the indicator lamp flashes while the machine is in operation, perform a "STATIONARY MACHINE" EXHAUST REGENERATION (↖ 3 - MAINTENANCE: OCCASIONAL MAINTENANCE).



AUTOMATIC EXHAUST REGENERATION DEACTIVATED INDICATOR LAMP

The indicator lamp comes on when the machine is running to indicate that the automatic exhaust regeneration is disabled (↖ SWITCHES).



HIGH EXHAUST GAS TEMPERATURE INDICATOR LAMP

The indicator lamp comes on while the machine is operating to indicate a high exhaust gas temperature. You can continue to use the machine (↖ SWITCHES).



EXHAUST LINE FAULT INDICATOR LAMP

If the indicator lights up or flashes when the machine is in operation, stop the engine immediately and consult your dealer.

INFORMATION SCREEN

 **HIGH BEAM HEADLIGHTS INDICATOR**

 **LOW BEAM HEADLIGHTS INDICATOR**

 **TURN SIGNAL INDICATOR**

 **PARKING BRAKE LAMP**

 **BEACON INDICATOR**

 **MAINTENANCE REQUIRED**

 **MAINTENANCE OVERDUE**

 **MAINTENANCE OVERDUE + NUMBER OF ERROR CODES**

 **BOOM ANGLE**

 **HYDRAULIC MOVEMENT NEUTRALIZATION**

 **DISABLING "AGGRAVATING" HYDRAULIC MOVEMENT CUT-OFF**

 **NOT USED**

 **FORWARD/NEUTRAL/REVERSE GEAR**

 **GEAR RATIO**

 **NOT USED**

 **NOT USED**

 **NOT USED**

 **WHEEL STEERING INDICATOR**

 **CLOCK**

 **DRIVING MODE**

 **WORK MODE**

 **NOT USED**





HOUR METER

- This screen is displayed for a few seconds when the ignition is switched on.



SPEEDOMETER

- This screen is displayed in driving mode.



HYDRAULIC FLOW RATE ADJUSTMENT

- This screen is displayed in work mode.

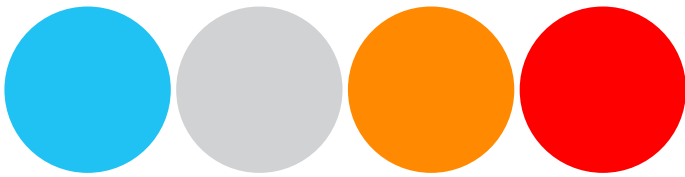







POP UP

- Blue POP UP: information message.
- Grey POP UP: operating message.
- Orange POP UP: warning message.
- Red POP UP: fault message, consult your dealer.



INFORMATION SCREEN

- Hold down the  or  button to choose.

-  Total hour meter.
-  Partial hour meter.
-  Instantaneous fuel consumption.
-  Average fuel consumption.
-  Fuel autonomy.
-  Tachometer.

9 - LONGITUDINAL STABILITY LIMITER AND WARNING DEVICE

⚠ IMPORTANT ⚠

The operator must respect the machine's load chart, and the operating mode according to the attachment.

This device warns the operator of the machine's longitudinal stability limits. However, lateral stability can reduce the load chart in the upper part, and this reduction is not detected by the device.

Depending on the type of work required, the operating modes of the longitudinal stability limiter and warning device allow the operator to operate the machine in complete safety.

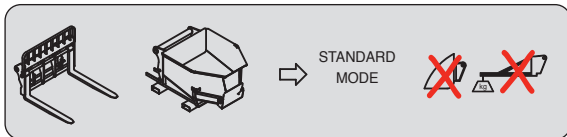
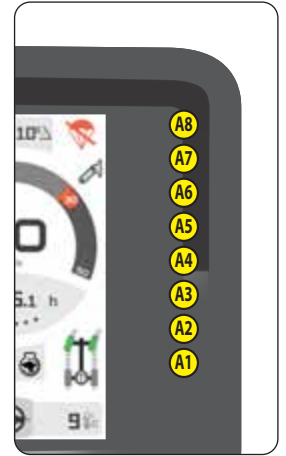

"HANDLING" MODE

USE ON FORKS

- By default, the device is in "HANDLING" MODE each time the machine is started.
- Protection against tilting forward during aggravating movements is guaranteed, except when the telescope is retracted.

STATUS OF THE DEVICE			
HALTED	SLOW SPEED 1 to 5 km/h	SPEED > 5 km/h	BOOM RETRACTED (★)
A4-A5 : Very slow intermittent sound alarm. A6 : Slow intermittent sound alarm. A7 : Fast intermittent sound alarm. A8 : Very fast intermittent sound alarm.	A7 : Fast intermittent sound alarm. A8 : Very fast intermittent sound alarm.	-No sound alarm.	-No sound alarm. -Indicator light on.

(★) Boom extension of 1 meter maximum and boom lift angle of 10° maximum. Regularly check that the indicator light works correctly under these conditions (⚠ MAINTENANCE: OCCASIONAL MAINTENANCE).

NOTE: When A9 is ON, it warns operator that the cut-off movement function is disabled (overridden).

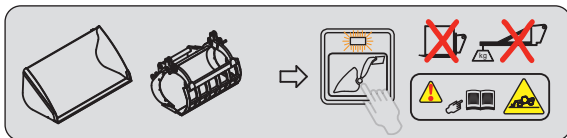

"BUCKET" MODE

USE WITH BUCKET

- Place the machine in transport position.
- Press the button, "BUCKET" MODE is confirmed by an audible signal and by the light coming on.
- Press this button again or switch off the ignition with the ignition key to return to "HANDLING" MODE.
- Protection against tilting forward during aggravating movements is guaranteed, except when the telescope is retracted.

STATUS OF THE DEVICE			
HALTED	SLOW SPEED 1 to 5 km/h	SPEED > 5 km/h	BOOM RETRACTED (★)
-The "BUCKET" mode deactivates after a few seconds if the machine remains stationary.	A6 : An audible signal upon passing into the red zone. -The hydraulic movements are adapted.	No sound alarm. -The hydraulic movements are adapted.	-No sound alarm. -Indicator light on.

(★) Boom extension of 1 meter maximum and boom lift angle of 10° maximum. Regularly check that the indicator light works correctly under these conditions (⚠ MAINTENANCE: OCCASIONAL MAINTENANCE).

NOTE: When A9 is ON, it warns operator that the cut-off movement function is disabled (overridden).

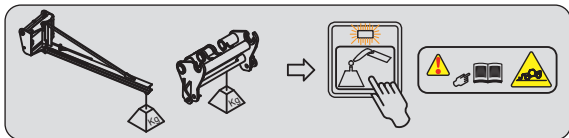

"SUSPENDED LOAD" MODE

USE WITH LIFTING DEVICE (offering a higher margin of safety)

- Place the machine in transport position.
- Press the  button; the "SUSPENDED LOAD" MODE is confirmed by an audible signal and by the indicator lamp coming on. Hydraulic tilting movements are neutralized, as well as the lifting movement when the longitudinal stability limit is reached (indicator lamp A8 on).
- Press this button again or switch off the ignition with the ignition key to return to "HANDLING" MODE.
- Protection against tilting forward during aggravating movements is guaranteed, except when the telescope is retracted.

STATUS OF THE DEVICE			
HALTED	SLOW SPEED 1 to 5 km/h	SPEED > 5 km/h	BOOM RETRACTED (★)
	A4-A5 : Very slow intermittent sound alarm. A6 : Slow intermittent sound alarm. A7 : Fast intermittent sound alarm. A8 : Very fast intermittent sound alarm.		-No sound alarm. -Indicator light  on.

- (★) Boom extension of 1 meter maximum and boom lift angle of 10° maximum. Regularly check that the indicator light  works correctly under these conditions (⚠ MAINTENANCE: OCCASIONAL MAINTENANCE).
 NOTE: When A9 is ON, it warns operator that the cut-off movement function is disabled (overriden).

A - VISUAL ALARMS

- A1 - A2 - A3: There is a significant reserve of longitudinal stability.
- A4 - A5: The machine is nearing the limit of longitudinal stability. Maneuver with care.
- A6: The machine is close to the longitudinal stability limit. Maneuver with care.
- A7: The machine is very close to the longitudinal stability limit. Manoeuvre with extreme caution.
- A8: The machine is at the authorized limit of longitudinal stability.

B - HYDRAULIC MOVEMENT CUT-OFF

- (★) Boom extension of 1 meter maximum and boom lift angle of 10° maximum. Regularly check that the indicator light  works correctly under these conditions (⚠ MAINTENANCE: OCCASIONAL MAINTENANCE).

"HANDLING" MODE

- A8: All "AGGRAVATING" hydraulic movements are cut off. Only perform de-aggravating hydraulic movements in the following order: retract and raise the boom.

"BUCKET" MODE

- A8: The boom lowering and extension movements are cut off; the other movements remain available.

"SUSPENDED LOAD" MODE



- A8: All "AGGRAVATING" and boom raising hydraulic movements are cut off. Only the boom retraction hydraulic movement is available.

C - DISABLING "AGGRAVATING" HYDRAULIC MOVEMENT CUT-OFF

⚠ IMPORTANT ⚠

Remain very vigilant during this operation. The only information available to the operator is the machine's dynamic stability.

In certain cases, in order to get out of a difficult situation, the operator can bypass this safety device. The  button temporarily disables the cutting-off of "AGGRAVATING" hydraulic movements.

- Hold down the  button; the indicator lamp will light (60 second time delay), and the  pictogram will appear on the information screen. Simultaneously perform the necessary "AGGRAVATING" hydraulic movement with extreme care.

D - STRAIN GAUGE

⚠ IMPORTANT ⚠

Disassembly or calibration of the strain gage is prohibited, this must only be done by specially trained personnel, consult your dealer.

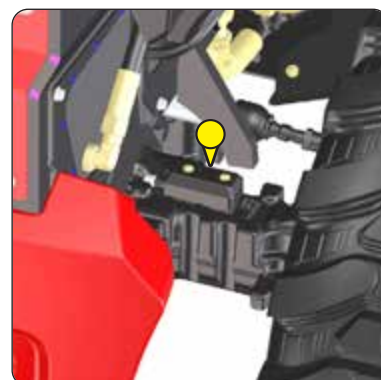

10 - INFORMATION SCREEN CONTROL BUTTONS

NOTE: The content of the "PREFERENCES" and "INFORMATION" menus varies according to the machine equipment.



INFORMATION MENU

- Press the button to display the "INFORMATION" menu
- Press the button to select from the menus and sub-menus.
- Press knob to confirm.

REPAIR	>	FAULTS
MAINTENANCE	>	MAINTENANCE RESET
GENERAL	>	IDENTIFICATION
	>	SOFTWARE VERSION



PREFERENCES MENU

- Press the button to display the "PREFERENCES" menu
- Press the button to select from the menus and sub-menus.
- Press knob to confirm.

SYSTEM	>	DATE AND TIME	
	>	LANGUAGES	
	>	UNITS	
	>	SCREEN	
	>	POP UPS	
	>	DIGICODE (OPTION)	
	>	CAMERAS (OPTION)	
	>	CUSTOMER CODE)	
	>	CONFIGURATION (customer or expert code)	>
		>	MAINTENANCE HOUR METER RESET

HYDRAULICS	>	STABILITY TEST		
	>	STABILITY REBALANCING		
	>	EASY CONNECT SYSTEM (OPTION)		
	>	CONFIGURATION (customer or expert code)	>	OVERRIDE
			>	MANUAL OVERRIDE NO DRIVER

ENGINE	>	FAN DRIVE VENTILATION REVERSAL
	>	REGENERATION
	>	STOP&START (OPTION)

EXPERT (expert code)	>	STABILITY CALIBRATION
	>	BOOM ANGLE SENSOR CALIBRATION
	>	PEDAL CALIBRATION INCHING
	>	CARRIAGE ANGLE CALIBRATION
	>	EXPERT CODE



BACK

- Press the button to return to the previous stage.



CONFIRMATION

- Press the button to move on to the next step.



MOVE UP

- Press the button to change menu.



MOVE DOWN

- Press the button to change menu.



11 - PUSH BUTTON PANEL

BUTTON FUNCTIONS

- Red button: Safety.
- Orange button: Transmission / Engine.
- Blue button: Hydraulics.
- Black button: Other.

BUTTON DIAGNOSTICS

- If all buttons are unlit, there is a power supply problem. Contact your dealer.
- If all buttons are flashing, there is a connection problem. Contact your dealer.



HYDRAULIC MOVEMENT NEUTRALIZATION

When driving on the road, it is highly recommended (mandatory in Germany) that you disconnect all hydraulic movement. The indicator lamp and  image on the information screen indicate use.



ROTATING BEACON LIGHT

The indicator lamp indicates it is in use.



"STATIONARY MACHINE" EXHAUST REGENERATION

 3 - MAINTENANCE: OCCASIONAL MAINTENANCE





AUTOMATIC EXHAUST REGENERATION DEACTIVATION















⚠ IMPORTANT ⚠

Deactivation of the automatic exhaust regeneration is a function that should only be used when necessary (in confined or unventilated spaces, etc.).

By default, the automatic exhaust regeneration is activated each time the machine is started.

- To deactivate the automatic exhaust regeneration, hold down the switch. The indicator lamp  lights up and an audible signal confirms deactivation.

- To reactivate the automatic exhaust regeneration, hold down the switch again. The  indicator lamp goes out to confirm reactivation.

EXHAUST REGENERATION MANAGEMENT			
SIGNALS	ACTIONS		
 + 1 short sound alarm. Moderate soot level.	Indicator lamp  comes on. It is preferable to wait for the automatic regeneration process to finish before removing the ignition key.	Or	Activate "stationary machine" exhaust regeneration ( 3 - MAINTENANCE: OCCASIONAL MAINTENANCE).
 +  + 1 short sound alarm. Moderate soot level, automatic regeneration disabled.	Enable automatic regeneration at the earliest possible time.	Or	Activate "stationary machine" exhaust regeneration ( 3 - MAINTENANCE: OCCASIONAL MAINTENANCE).
 +  + permanent sound alarm. High soot level.	Engine speed limited to 1,200 rpm, only a "stationary machine" regeneration must be performed ( 3 - MAINTENANCE: OCCASIONAL MAINTENANCE).		
 +  +  + permanent sound alarm. High soot level, automatic regeneration disabled.			
 +  +  + 1 short sound alarm. Very high soot level, particle filter clogged.	<i>If the machine is under-performing, stop the machine and contact your dealer.</i>		



STOP AND START (OPTION)

< OPTIONS - ENGINE/POWER



FAN REVERSAL (OPTION)

< OPTIONS - ENGINE/POWER



NOT USED



"MANUAL MODE" AUTOMATIC PARKING BRAKE

- Press the button to activate. The indicator lamp will show it is in use.
- Press the button again to deactivate.



AUTOMATIC PARKING BRAKE

The function is used to engage the parking brake when the machine is stopped and to release the parking brake when the machine movement conditions are met.

- Press the button to activate. The indicator lamp will show it is in use.
- Press the button again to deactivate.



DISABLING "AGGRAVATING" HYDRAULIC MOVEMENT CUT-OFF

< LONGITUDINAL STABILITY LIMITER AND WARNING DEVICE



ENGINE SPEED MEMORIZATION (OPTION)

< OPTIONS - ENGINE/POWER



SPEED LIMITER (OPTION)

< OPTIONS - ENGINE/POWER



NOT USED



TILT CIRCUIT LOCKING

- Press the button to shut off the tilt circuit hydraulic movements. The indicator lamp indicates it is in use.
- Press the button again to deactivate.



ATTACHMENT CIRCUIT LOCKING (OPTION)

- Press the button to shut off the attachment circuit hydraulic movements. The indicator lamp indicates it is in use.
- Press the button again to deactivate.



"BUCKET" MODE

< LONGITUDINAL STABILITY LIMITER AND WARNING DEVICE



"SUSPENDED LOAD" MODE

< LONGITUDINAL STABILITY LIMITER AND WARNING DEVICE



ATTACHMENT CIRCUIT MANUAL OVERRIDE (OPTION)

< OPTIONS - ENGINE/POWER











ATTACHMENT CIRCUIT FLOW RATE LIMITER (OPTION)

< OPTIONS - ENGINE/POWER

12 - SWITCHES

NOTE: The location of the switches may vary depending on the options.

-  **REAR FOG LIGHTS (OPTION)** \triangleleft OPTIONS - LIGHTS
-  **HAZARD WARNING LIGHTS (OPTION)**
-  **ROTATING BEACON LIGHT (OPTION)** \triangleleft OPTIONS - SAFETY
-  **FRONT AND REAR WORKLIGHTS (OPTION)** \triangleleft OPTIONS - LIGHTS
-  **BOOM HEAD WORKLIGHTS (OPTION)** \triangleleft OPTIONS - LIGHTS
-  **BLUE POULTRY FARMING WORKLIGHTS (OPTION)** \triangleleft OPTIONS - LIGHTS
-  **ROOF WINDSHIELD WIPER AND WASHER (OPTION)** \triangleleft OPTIONS - DRIVER'S CAB
-  **ELECTRIC PREDISPOSITION ON BOOM (OPTION)** \triangleleft OPTIONS - LIGHTS



13 - DIAGNOSTIC PLUG

- Remove the access panel 1 to access the diagnostic plug 2.

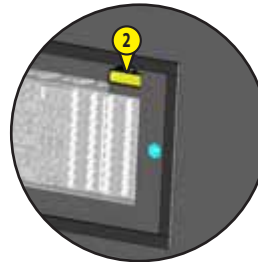

14 - USB RECHARGING SOCKET



15 - HORN BUTTON

Pressing the button will sound the audible alarm.



16 - FRONT AND REAR WINDSHIELD WIPER SWITCH

FRONT WINDSHIELD WIPER

- A - Front windscreen wiper stop.
- B - Front windscreen wiper low speed.
- C - Front windscreen wiper high speed.
- D - Front windscreen wiper intermittent.
- E - Front windscreen washer by pressing.

REAR WINDSHIELD WIPER

- F - Rear windscreen wiper stop.
- G - Rear windshield wiper.
- H - Rear windscreen washer by pressing.

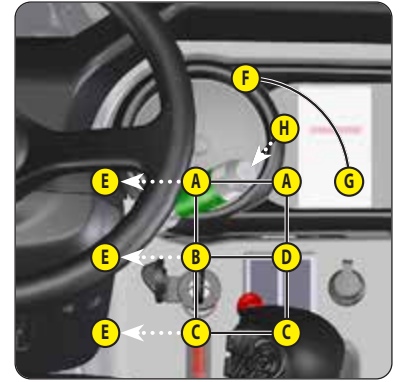

17 - FUSES AND RELAYS

A file gives a description and how to use the components of the panel described below

STICKERS AND PLATES.

- Remove access panel 1 to gain access to the fuses and relays. Replace a blown fuse with a new fuse of the same quality and rating. Never use a repaired fuse.

F1	5A	Screen/navigator wake-up.
F2	7,5A	Water in fuel sensor. Alternator excitation. ECM wake-up.
F3	5A	Anti-theft device predisposition. Diagnostics plug.
F4	10A	JSM joystick. "Transmission" electronic control unit.
F5	15A	Car radio (OPTION).
F6	5A	Boom angle sensors.
F7	20A	Main ECU power supply.
F8	7,5A	Boom head solenoid valve (OPTION).
F9	10A	Relay (K2 K3).
F10	2A	Wheel alignment sensors.
F11	15A	Flashing light unit power supply (K8) (OPTION).
F12	5A	Rear fog light switch (OPTION).
F13	15A	Working lights on boom switch (OPTION).
F14	7,5A	Relay (K4).
F15		Unused.
F16		Red rotating beacon light + flashing light (OPTION). Green rotating beacon light (OPTION).
F17	15A	Rear windshield wiper and windshield washer. Roof windshield wiper (OPTION).
F18	15A	Front windshield wiper and windshield washer. Relay (K5).
F19	30A	Power supply (F27 F28 F29 F30).
F20	20A	Heating.

F21	5A	Left sidelights (OPTION).
F22	5A	Right sidelights (OPTION).
F23	15A	Dipped beam headlights (OPTION).
F24	15A	Main beam headlights (OPTION).
F25	7,5A	Right indicator lights (OPTION).
F26	7,5A	Left indicator lights (OPTION).
F27	7,5A	Boom head electric power socket (OPTION). Camera (OPTION).
F28	5A	Fuel pump.
F29	10A	Pneumatic seat (OPTION).
F30	20A	Front work lights (OPTION). Rear work lights (OPTION).
F31	20A	Lighting, horn and indicator switch.
F32	15A	Relay (K13) (OPTION).
F33	5A	Diagnostics plug. Anti-theft device predisposition.
F34	7,5A	Warning device. Roof light.
F35	10A	Car radio (OPTION).
F36	10A	Main ECU power supply.



F37	10A	Rear windshield wiper power supply.
F38	10A	Front windshield wiper power supply.
F39	5A	Blue poultry farming worklights (OPTION).
F40	30A	Air conditioning electric fan (OPTION).

F51		Unused.
F52	2A	Immobilizer (OPTION).
F53	15A	Relay (K1).
F54	2A	Dashboard power supply.

F61		Unused.
F62	40A	Engine preheat.
F63	60A	Module 5 fuses (F1 - F20).
F64	50A	Ignition switch.
F65	40A	Starter control.
F66	20A	Engine ECU power supply.

F67		Unused.
F68		Unused.

K1		Valve control relay "EGR".
K2		Backup lights (OPTION). Reversing sound alarm.
K3		Stop lights (OPTION).
K4		Working lights on boom (OPTION).
K5		Front windshield intermittent function.
K6		Rotating beacon light.
K7		Heating.
K8		Flashing light unit.

K9		Engine preheat.
K10		Starter control.

K13		Flashing light unit power supply.
K14		Hazard warning lights.

18 - FORWARD/NEUTRAL/REVERSE SELECTOR

Changing the direction of travel should take place at low speed without acceleration.

- FORWARD: Push the switch forward (position A).
- REVERSE: Push the switch backward (position B). Reversing lights and a backup alarm indicate that the machine is traveling in reverse.
- NEUTRAL: The switch must be in the neutral position (position C) to start the machine.

SAFETY FOR MOVING THE MACHINE

The operator must observe the following sequence to move the truck forward or backward:

- 1 - sit down correctly in the driver's seat,
- 2 - deactivate the parking brake,
- 3 - engage forward or reverse gear.

NOTE: The alternate display of the forward or reverse section arrow



on the information screen requires the selector to be set to neutral.

To stop the machine without switching off the ignition, the following sequence must be followed:

- 1 - set the forward/reverse selector to neutral,
- 2 - activate the parking brake,
- 3 - get out of the machine.

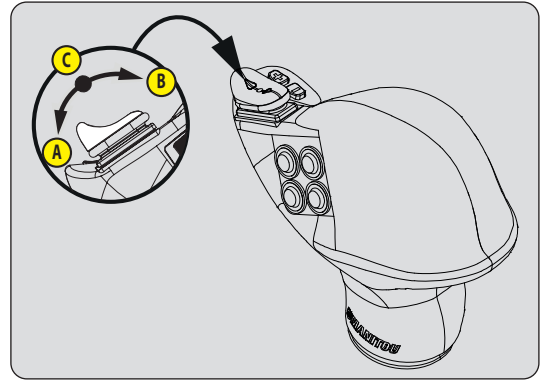

OPENED CAB

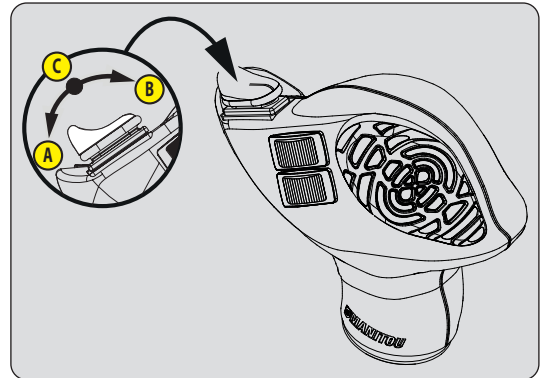

CLOSED CAB

19 - GEAR SELECTOR

The gear can be selected by means of the (-) and (+) buttons. The engaged gear is

indicated on the information screen .

- GEAR 1: Recommended for work that calls for more traction or thrust force at low speed (e.g. silaging, earthwork, manure, towing on steep slope, etc.).
- GEAR 2: Recommended for all other work at low or high speed, making the machine versatile (e.g. handling, loading, livestock feeding, towing on the flat or a slight slope, driving on roads, etc.).



OPENED CAB



CLOSED CAB

20 - STEERING SELECTION

⚠ IMPORTANT ⚠

*Before selecting one of the three steering possibilities, align the 4 wheels in relation to the machine axis.
Never change the steering mode whilst driving.*



The green indicator lights on the information screen  come on to indicate the alignment of the wheels relative to the machine.

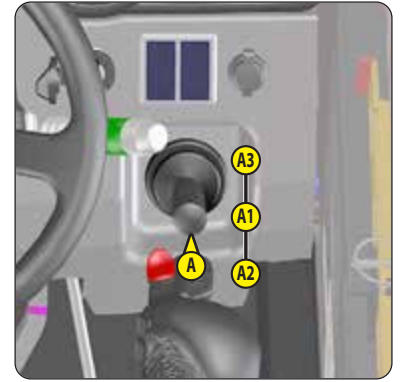

A - STEERING SELECTION LEVER

- A1 - Front steering wheels (road mode).
- A2 - Front and rear steering wheels in opposite directions (short steering).
- A3 - Front and rear steering wheels in the same direction (crab steering).



WHEEL ALIGNMENT CONTROL

*Check the alignment of the front and rear wheels each time the lift truck is started.
Regularly check the alignment of the wheels when using the lift truck.
The wheels must be aligned and the lift truck must be in front steering wheels mode when used on public roads.
A green light illuminates on the dashboard when the wheels are aligned.
Contact your dealer if you have any questions.*

- Select "short steering".
- Turn the steering wheel and bring the rear wheels into alignment until the  indicator lamps light on the rear wheels.
- Select "road driving".
- Turn the steering wheel and bring the rear wheels into alignment until the  indicator lamps light on the front wheels.

21 - ACCELERATOR PEDAL

ENGINE SPEED ACCELERATION

- Press the accelerator pedal to increase the engine speed and start moving the machine if forward or reverse gear is selected.

NOTE: Use the inching pedal to shift the start of machine movement towards the top speed and therefore transfer the engine's power to the boom's hydraulic controls.

ENGINE SPEED DECELERATION

The service brake pedal does not need to be used to slow the machine down, with or without a trailer. Use of the engine brake is enough.

- Release the accelerator pedal proportionally to the required slowing, and if necessary press on the service brake pedal to immobilize the machine.



22 - SERVICE BRAKE AND INCHING PEDAL "INCHING"

In the first part of the travel, the pedal enables gradual cut-off of the transmission to perform inching. In the second part of the travel, the pedal acts on the front axle through a hydraulic braking system to immobilize the machine.



23 - FUNCTION FILES

These files contain, among other things, the description of the hydraulic controls and the load charts for the attachments used on the machine.



24 - HYDRAULIC BOOM CONTROLS

⚠ IMPORTANT ⚠

Do not try to modify the hydraulic pressure of the system. If it malfunctions contact your dealer. ANY MODIFICATION INVALIDATES THE WARRANTY AND YOU WILL BE CRIMINALLY LIABLE IN THE EVENT OF AN ACCIDENT.

Use the hydraulic controls gently without jerking to avoid incidents caused by shaking the machine.

NOTE: When driving on the road, it is highly recommended (mandatory in Germany) that you cut off all the hydraulic movements (☞ PUSH BUTTON PANEL).

A1 - LIFTING

A2 - LOWERING

B1 - CROWD

B2 - DUMP

C1 - TELESCOPIC BOOM EXTENSION

C2 - TELESCOPIC BOOM RETRACTION

D1 - ATTACHMENT (OPTION)

D2 - ATTACHMENT (OPTION)

E - BOOM HEAD SOLENOID VALVE (OPTION)

☞ OPTIONS - LIFTING FUNCTIONS

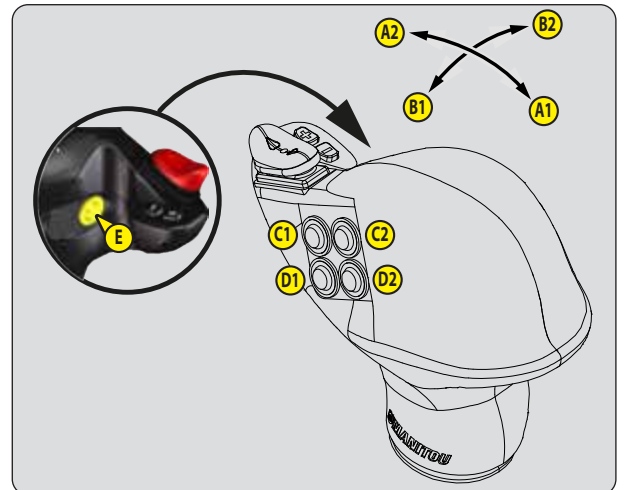

OPENED CAB

HYDRAULIC CONTROLS ACTIVATION (CLOSED CAB)

This safety device prevents accidental operation of the hydraulic lifting, tilting, telescoping and attachment controls.

- Place your hand on the lever, activate the hydraulic controls by contact on sensor 1 and perform the hydraulic movement.
- Hydraulic controls activation is maintained on a timer while the machine is being used.
- If necessary, reactivate the hydraulic controls.

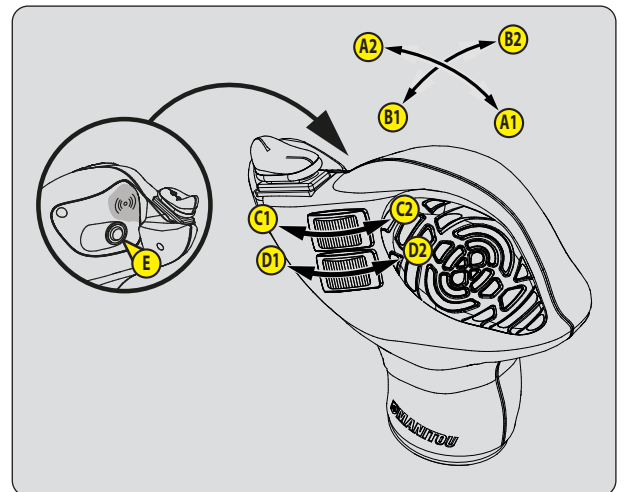
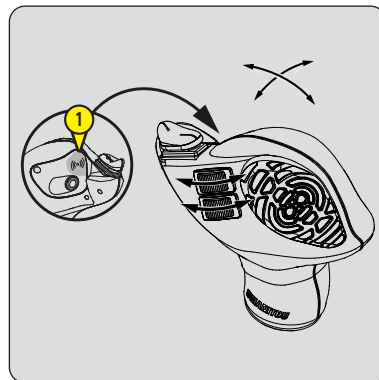

25 - LEVEL INDICATORS

Enables the operator to check that the lift truck is fully leveled with the ground.

25a : Lateral level indicator

25b : Longitudinal level indicator.

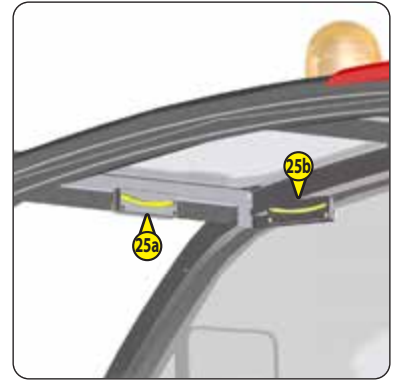

26 - HEATER CONTROL

A - FAN CONTROL

This 3-speed control allows the air to be ventilated through the air vents.

B - TEMPERATURE CONTROL

Adjusts the temperature inside the cab.

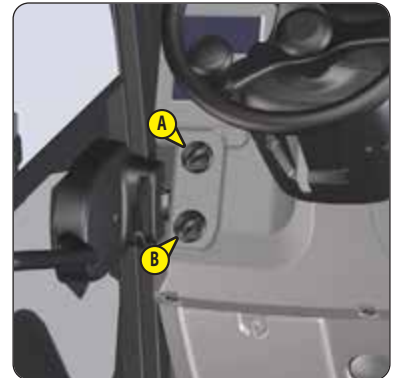

27 - HEATING VENTS

These swiveling heating vents, which can be shut off, allow you to direct and adjust the flow inside the cab.

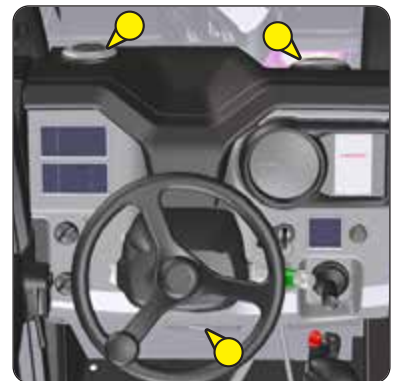

28 - DOOR OPENING AND CLOSING HANDLES (CLOSED CAB)

Two keys are provided with the machine to enable the cab to be locked.

OUTSIDE HANDLE

DOOR OPENING

- Place hand on handle 1, push button 2 and pull the door outwards.

CLOSING THE DOOR

- Place hand on the handle 1 and push the door inward.

INSIDE HANDLE

DOOR OPENING

- Lift lever 3 and push the door outwards.

CLOSING THE DOOR

- Place hand on the handle 4 and pull the door inwards.

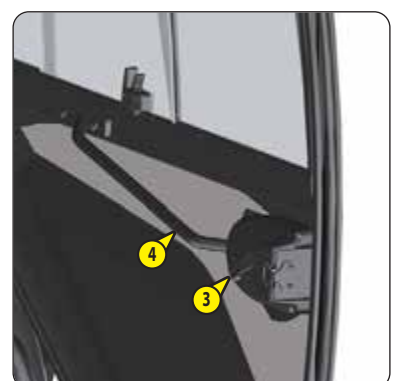
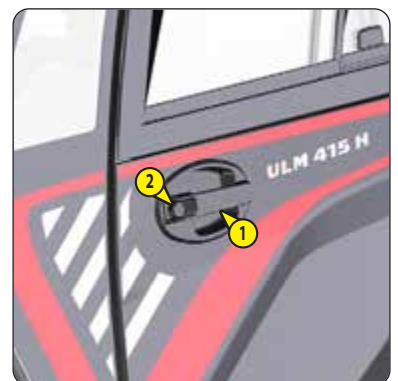

29 - PRESSURE RELIEF VALVE

⚠ IMPORTANT ⚠

The pressure relief valve helps with closing the cab door. Do not leave anything in front of it or obstruct it.



30 - SIDE WINDOWS OPENING AND CLOSING HANDLES (CLOSED CAB)

- Squeeze the latch 1 and push the front window into the desired position. Two notches allow the window to be locked in completely open or closed position.
- Squeeze the latch 2 and push the rear window into the desired position. Two notches allow the window to be locked in completely open or closed position.



31 - REAR WINDOW STAY (CLOSED CAB)



32 - CAB STORAGE

Ensure that the operator's manual is in its place in the cab storage compartment.



33 - ROTATING BEACON LIGHT

The magnetic rotating beacon light must be clearly visible on the roof of the cab and plugged in to 12 V socket 1.

⏏ PUSH BUTTON PANEL

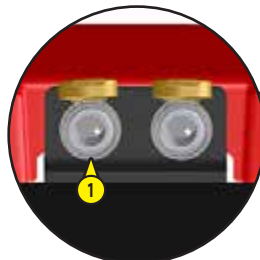

34 - ROOF LIGHT



35 - BOOM SAFETY WEDGE

⚠ IMPORTANT ⚠

Only use the wedge supplied with the machine.

The machine is equipped with a boom safety wedge that must be installed on the rod of the lifting cylinder when working beneath the boom.



36 - FUEL TANK

As far as possible, keep the fuel tank well filled in order to minimize condensation due to the atmospheric conditions.

⚠ IMPORTANT ⚠

Never smoke or approach with a flame during filling operations or when the tank is open.

Never refill while the engine is running.

- If necessary, add diesel (↩ 3 - MAINTENANCE: LUBRICANTS AND FUEL).
- Remove the cap 1.

NOTE: the standard fuel cap is keyless, a keyed fuel cap is available (↩ SECURITY OPTIONS).

- Fill the fuel tank with clean diesel filtered through the filler port.
- Refit the cap.
- Visually check that there is no leakage in the tank and pipes.



37 - FLOOR EVACUATION



TOWING DEVICE

⚠ IMPORTANT ⚠

Do not tow a trailer or an attachment that is not in perfect working condition.

Using a trailer in poor condition may affect the machine's steering and braking, and hence the safety of the assembly.

If a third party helps in coupling or uncoupling the trailer, this person must remain visible to the driver at all times and must wait until the machine has stopped, the parking brake is activated and the engine is switched off before performing the operation.

Located at the rear of the machine, this device is used to attach a trailer. Its capacity is limited for each machine by the authorized gross vehicle weight, tractive effort and maximum vertical force on the coupling point. This information is given on the manufacturer's plate fixed to each machine (← IDENTIFICATION OF THE MACHINE).

- To use a trailer, see current regulations in your country (maximum running speed, braking, maximum weight of trailer, etc.).
- Verify the trailer's condition before using it (tire condition and pressures, electrical connection, hydraulic hose, brake system, etc.).

1 - TOWING PIN

⚠ IMPORTANT ⚠

Be careful not to get your fingers caught or crushed during this operation.

Do not forget to put the cotter pin back in place.

When uncoupling, make sure that the trailer is supported independently

COUPLING AND UNCOUPLING THE TRAILER

- To couple the trailer, position the machine as close as possible to the trailer ring.
- Activate the parking brake and switch off the engine.
- Remove the pin 1, lift the towing pin 2 and place or remove the trailer ring.



OPTIONS - DRIVER'S CAB

1 - AIR CONDITIONING CONTROLS (CLOSED CAB).....	2-54
2 - SUN VISOR.....	2-55
3 - DRIVER'S SEAT	2-55
4 - CAR RADIO	2-56
5 - FLOOR MAT.....	2-56
6 - INTERNAL REAR-VIEW MIRROR.....	2-57
7 - TELEPHONE HOLDER	2-57
8 - STEERING WHEEL ADJUSTMENT LEVER	2-57
9 - WATERPROOF DOCUMENT HOLDER	2-57
10 - ORANGE SEAT BELT	2-57
11 - ROOF WINDSHIELD WIPER AND WASHER	2-57

1 - AIR CONDITIONING CONTROLS (CLOSED CAB)

⚠ IMPORTANT ⚠

The air conditioning only works if the machine has been started.

When using your air conditioning, it is essential to work with the cab closed.

In winter: So as to ensure that the air conditioning unit is correctly operated and completely efficient, start up the compressor once a week, even for a short period of time, in order to lubricate the internal seals.

In cold weather: Warm the engine before switching on the compressor, in order to allow the coolant that has collected in the liquid state at the lowest point of the compressor's circuit to turn into gas under the effect of the heat given off by the engine, as the compressor is liable to be damaged by coolant in the liquid state.

If it seems to you that the air conditioning is not working properly, have it inspected by your dealer.

Never try to repair any faults yourself.

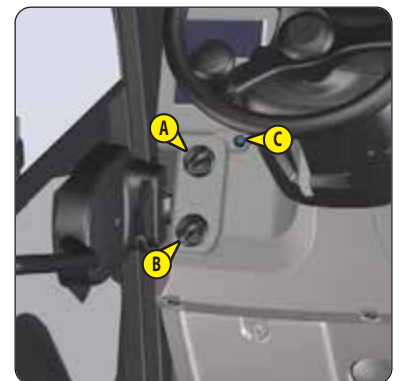

A - FAN CONTROL

This 3-speed control allows the air to be ventilated through the air vents.

B - TEMPERATURE CONTROL

Adjusts the temperature inside the cab.

C - AIR CONDITIONING CONTROL

This control with a pilot light allows the air conditioning unit to be switched on.

HEATING MODE

- The controls must be adjusted in the following way:
 - C - Control with pilot light off.
 - B - At the desired temperature.
 - A - At the desired speed: 1, 2 or 3.

AIR CONDITIONING MODE

- The controls must be adjusted in the following way:
 - C - Control with indicator lamp on.
 - B - At the desired temperature.
 - A - At the desired speed: 1, 2 or 3.

DEFROST MODE

- The controls must be adjusted in the following way:
 - C - Control with indicator lamp on.
 - B - At the desired temperature.
 - A - At speed 2 or 3.
- For optimum effectiveness, close the heating vents.

2 - SUN VISOR

A - WINDSHIELD VISOR

B - ROOF VISOR

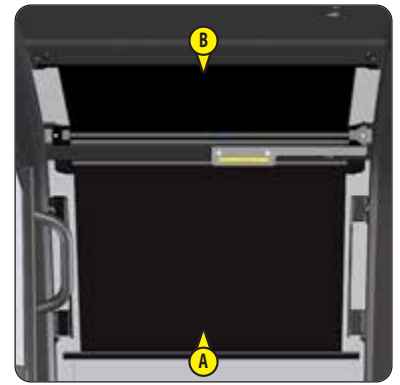

3 - DRIVER'S SEAT

For increased comfort, adjust the seat to your requirements and adopt the correct position in the driver's cab.

⚠ IMPORTANT ⚠

Under no circumstances must the seat be adjusted while the machine is moving.

MAINTENANCE

⚠ IMPORTANT ⚠

*A moving backrest increases the risk of an accident!
Do not clean the driver's seat with a high pressure cleaner.*

Dirt may adversely affect the correct functioning of the seat. For this reason, make sure your seat is always clean.

- It is not necessary to remove the cushions from the seat frame to wash them.
- Avoid wetting the cushion fabric when cleaning it. First check the resistance of the fabric on a small concealed area before using any fabric and plastic cleaner.

FABRIC UPHOLSTERED "MECHANICAL" DRIVER'S SEAT

WEIGHT ADJUSTMENT

- Sit on the seat.
- Turn button 1 to adjust according to the operator's weight.

BACKREST ANGLE ADJUSTMENT

⚠ IMPORTANT ⚠

If you do not support the backrest when making adjustments, it swings completely forward.

- Support the backrest, pull the lever 2 and tilt the backrest to the desired position.

LONGITUDINAL ADJUSTMENT

- Engage the locking lever 3 in the desired position.
- Once locked, you can no longer move the seat into another position.



FABRIC UPHOLSTERED "PNEUMATIC" DRIVER'S SEAT

FABRIC UPHOLSTERED "LOW FREQUENCY PNEUMATIC" DRIVER'S SEAT

SEAT WEIGHT AND HEIGHT ADJUSTMENT

Adjust the weight when the driver is sitting on the seat.

- Switch on the machine's ignition.
- Move the weight adjustment lever 1 upwards to increase the weight or downwards to reduce it.
- The min. and max. weight can be set by engaging the upper or lower limit switch.
- The driver's weight is correctly adjusted when the arrow is in the center of the indicator 2.
- The seat height can be adjusted within this zone.

NOTE: To avoid health problems, it is recommended that the weight adjustment should be checked and adjusted before starting the machine.

⚠ IMPORTANT ⚠

To avoid damage, do not operate the compressor for more than 1 minute.



LONGITUDINAL ADJUSTMENT

- Unlock the locking lever 3.
- Slide the seat to the desired position.
- Release the lever and be sure it returns to the lock position.

LUMBAR ADJUSTMENT

This increases the comfort of the seat and the driver's freedom of movement.

- Turn the handle 4 upward to adjust the height and depth of the lumbar support on the upper part of the backrest.
- Turn the handle 4 downward to adjust the height and depth of the lumbar support of the lower part of the backrest.

BACKREST ANGLE ADJUSTMENT

- Support the backrest, pull the lever 5 and tilt the backrest to the desired position.

⚠ IMPORTANT ⚠

If you do not support the backrest when making adjustments, it swings completely forward.

4 - CAR RADIO

A - RADIO PLAYER

B - REMOTE MIKE

C - RADIO ANTENNA

D - SPEAKER

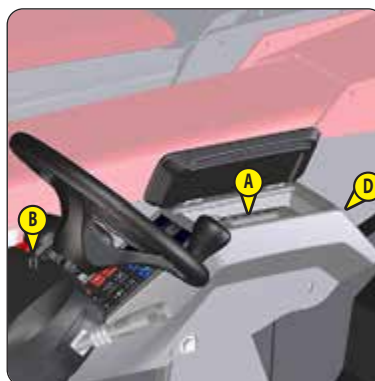

5 - FLOOR MAT



6 - INTERNAL REAR-VIEW MIRROR



7 - TELEPHONE HOLDER



8 - STEERING WHEEL ADJUSTMENT LEVER

This handle enables the angle and height of the steering wheel to be adjusted.

- Pull the knob backward.
- Adjust the steering wheel to the desired position.
- Push the knob back to lock the steering wheel in position.

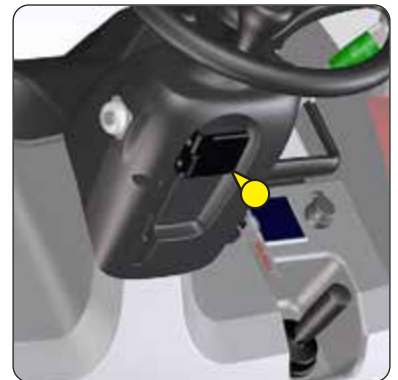

9 - WATERPROOF DOCUMENT HOLDER



10 - ORANGE SEAT BELT

⚠ IMPORTANT ⚠

*Under no circumstances must the machine be used if the seat belt is defective (fixing, locking, cuts, tears, etc.).
Immediately repair or replace the seat belt.*

- Sit correctly on the seat.
- Check that the seat belt is not twisted.
- Place the seat belt at hip level.
- Attach the seat belt and check that it locks.
- Adjust the seat belt to your body shape without compressing your pelvis and without excessive slack.



11 - ROOF WINDSHIELD WIPER AND WASHER

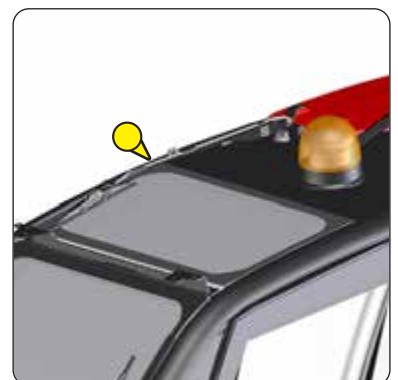

OPTIONS - ENGINE/POWER



1 - "STOP&START" ENGINE	2-58
2 - CYCLONIC PRE-FILTER	2-59
3 - ENGINE BLOCK HEATER	2-59
4 - FUEL TANK STRAINER	2-59
5 - RAPID DRAINAGE CONNECTION	2-59
6 - FAN REVERSAL	2-60
7 - ATTACHMENT CIRCUIT MANUAL OVERRIDE	2-60
8 - ENGINE SPEED REGULATOR	2-61
9 - SPEED LIMITER	2-61

1 - "STOP&START" ENGINE

This function can take charge of engine shutdown and restart to reduce consumption. It can be used if all of the following conditions are met within a timeframe defined by the operator.

- Engine on.
- Engine speed less than 1,000 rpm.
- No driver presence.
- No manual override in progress.
- No "stationary machine" exhaust regeneration.
- Parking brake activated.
- Engine coolant temperature higher than 50°C.

TIME DELAY ADJUSTMENT

- Press the button  to display the "PREFERENCES" menu.
- Press the button  to select from the menus and sub-menus.



ENGINE > STOP&START

- Select a time delay between 1 and 30 minutes and press the  button to confirm.

ACTIVATION OF AUTOMATIC ENGINE CUT-OUT

- Press the  button to activate. The indicator light will come on, showing that it is in use.

OR

- Press the button  to display the "PREFERENCES" menu.
- Press the button  to select from the menus and sub-menus.

ENGINE > STOP&START

- Activate the automatic engine cut-out and press the  button to confirm.

OPERATION

- The engine will stop automatically after the selected timeout has elapsed.
- NOTE: if the driver's door is closed, the electrical contact is cut off when the door is opened.
- Press the accelerator pedal or activate the hydraulic control lever to restart the engine.



The "STOP&START" function does not under any circumstances replace machine shutdown. You must shut down the machine at the end of the job or the end of the day (⚠ 1 - OPERATING AND SAFETY INSTRUCTIONS: OPERATOR INSTRUCTIONS: OPERATING INSTRUCTIONS WITH AND WITHOUT LOAD: G - STOPPING THE MACHINE).

2 - CYCLONIC PRE-FILTER



3 - ENGINE BLOCK HEATER

Enables the engine to be kept warm during prolonged periods of stoppage and thus improves engine starting.

ENVIRONMENTAL CONDITIONS FOR USE:

- Maximum ambient temperature for using preheating: + 25 °C.

CONDITIONS FOR CONNECTION AND USE OF PREHEATING:

- The preheating system should not be used for an external ambient temperature higher than + 25 °C.
- It is essential that the power supply to the preheating system:
 - Is effected with a cable that conforms to the installation standards in force and contains a protective earth conductor.
 - Contains an appropriate sectioning system.
 - Include an appropriate short-circuit protection system (fuses or circuit breaker) and a ground-fault circuit breaker, sensitive to 30 mA.
- Only connect to and disconnect from the power supply 1 with the unit switched off and the engine stopped.



⚠ IMPORTANT ⚠

Make sure that the electrical extension 2 is still in its right place in the storage net.

4 - FUEL TANK STRAINER

The fuel tank strainer protects the fuel system from impurities when filling the tank.



5 - RAPID DRAINAGE CONNECTION

A - DRAINAGE CONNECTION

B - DRAINAGE HOSE

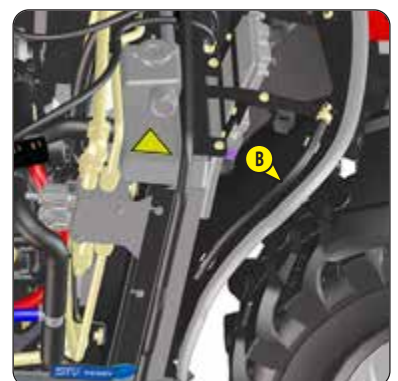

6 - FAN REVERSAL



AUTOMATIC FAN REVERSAL (OPTION)

Cleans the radiator core and the grille of the engine hood by reversing the air flow.

⚠ IMPORTANT ⚠

*The ventilation reversal is operational from an engine coolant temperature of 40 °C.
When in use, beware of the risk of projection into the eyes.*

- The indicator lamp is on, the fan operates in self-cleaning mode for a few seconds once every 3 minutes.
- The default cycle time is 3 minutes.
- Press button B to display the "PREFERENCES" menu
- Turn knob A to navigate through the menus and sub-menus.

ENGINE	"FAN DRIVE" VENTILATION REVERSAL
--------	----------------------------------

- Select the cycle time and press knob A to confirm.



FORCED FAN REVERSAL (OPTION)

- Press the button to force a cleaning cycle. The indicator lamp will light when it is in use.
- Wait for the cycle to finish before forcing another.







7 - ATTACHMENT CIRCUIT MANUAL OVERRIDE

⚠ IMPORTANT ⚠





This OPTION should only be used with an attachment that requires a continuous hydraulic movement such as: pruner, sweeper, feed wagon, mixer, sprayer, etc. It is strictly prohibited in handling and for all other attachments (winch, crane, crane jib with winch, hook, etc.).

NOTE: it is possible to use the forced operation function without the driver in the cab, please contact your dealer.

USING AND STORING MANUAL OVERRIDE

- Press the  button to select the operating mode .
- Hold down the  button;  will appear on the information screen.
- Press buttons   to set the flow rate.
- Press the  button to confirm and set.

ACTIVATING THE STORED MANUAL OVERRIDE



- Press the  button to activate manual override.
- Confirm by pressing the  button again or pressing the  button.
- Press the  button again to deactivate.

8 - ENGINE SPEED REGULATOR





⚠ IMPORTANT ⚠

The engine speed regulator cannot under any circumstances be used while driving on the road.

SPEED MEMORIZATION

- Control the engine speed with the accelerator pedal.
- Hold down the  button to memorize the engine speed.
- Press the  button again to return to idle speed.

ACTIVATING THE MEMORIZED ENGINE SPEED

- Press the  button to activate the memorized engine speed.
- Confirm by pressing the  button again or pressing the  button.
- Press the  button again to return to idle speed.

9 - SPEED LIMITER







⚠ IMPORTANT ⚠

BE CAREFUL when using the speed limiter while driving.





As soon as  appears on the information screen, selecting the speed with knob  will act directly on the machine and may cause it to decelerate sharply. Always reduce speed before use.

SPEED LIMITER USE AND MEMORIZATION

- Hold down the  button,  will appear on the information screen.
- Press the knob  or  to select the speed.
- Press the  button to confirm and set.
- The memorized speed will be displayed on the information screen .

ACTIVATING THE MEMORIZED SPEED

- Press the  button to activate. The indicator light will come on, showing that it is in use.
- The speed limiter recall  on the information screen also indicates that it is in use.
- Press the button again to deactivate.

OPTIONS - LIFTING FUNCTIONS

1 - HYDRAULIC LOCKING CARRIAGE "EURO".....	2-63
2 - HYDRAULIC LOCKING CARRIAGE "TSS".....	2-63
3 - HYDRAULIC ATTACHMENT LINE + EASY HYDRAULIC ATTACHMENT CONNECTION	2-63
4 - BOOM HEAD ELECTROVALVE - TWO HYDRAULIC FUNCTIONS.....	2-64
5 - HIGH FLOW HYDRAULIC CIRCUIT	2-65
6 - HYDRAULIC ATTACHMENT LINE "TSS".....	2-65
7 - ATTACHMENT CIRCUIT FLOW RATE LIMITER	2-65
8 - EXTERIOR DRAIN-BACK.....	2-65
9 - BOOM HEAD ELECTROVALVE - ONE HYDRAULIC FUNCTION + HYDRAULIC ATTACHMENT LOCKING.....	2-66
10 - BOOM ELECTRICAL PREDISPOSITION.....	2-67
11 - LIFTING RING ON CARRIAGE	2-67
12 - MATERIAL DEFLECTOR ON BOOM HEAD	2-67

1 - HYDRAULIC LOCKING CARRIAGE "EURO"

4 - ATTACHMENTS



2 - HYDRAULIC LOCKING CARRIAGE "TSS"

4 - ATTACHMENTS



3 - HYDRAULIC ATTACHMENT LINE + EASY HYDRAULIC ATTACHMENT CONNECTION

HYDRAULIC ATTACHMENT LINE

ATTACHMENT EASY HYDRAULIC CONNECTION



For easy connection and disconnection of hydraulic attachments.

PUSH BUTTON OPERATION

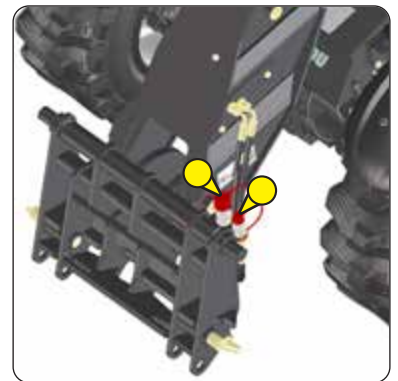
- Switch on the machine's ignition.
- Press for two seconds on pushbutton 1 to release the attachment circuit hydraulic pressure. Operation is confirmed by two hazard warning lights being activated.
- Connect or disconnect the rapid connectors of the hydraulic attachment (4 - ATTACHMENTS: PICKING UP THE ATTACHMENTS).



PREFERENCES MENU BUTTON OPERATION

- Switch on the machine's ignition.
- Press the button  to display the "PREFERENCES" menu.
- Press the button  to select from the menus and sub-menus.

HYDRAULICS	>	EASY CONNECT SYSTEM
------------	---	---------------------
- Press knob  to confirm.
- Follow the steps described on the information screen. Operation is confirmed by two hazard warning lights being activated.
- Connect or disconnect the rapid connectors of the hydraulic attachment (4 - ATTACHMENTS: PICKING UP THE ATTACHMENTS).





4 - BOOM HEAD ELECTROVALVE - TWO HYDRAULIC FUNCTIONS

Enables use of two hydraulic functions on the attachment circuit.

ATTACHMENT EASY HYDRAULIC CONNECTION

For easy connection and disconnection of hydraulic attachments.

PREFERENCES MENU BUTTON OPERATION

- Switch on the machine's ignition.
- Press the button  to display the "PREFERENCES" menu.
- Press the button  to select from the menus and sub-menus.

HYDRAULICS > EASY CONNECT SYSTEM

- Press knob  to confirm.
- Follow the steps described on the information screen. Operation is confirmed by two hazard warning lights being activated.
- Connect or disconnect the rapid connectors of the hydraulic attachment (<4 - ATTACHMENTS: PICKING UP THE ATTACHMENTS).

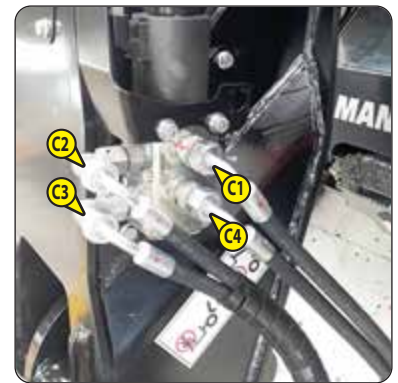
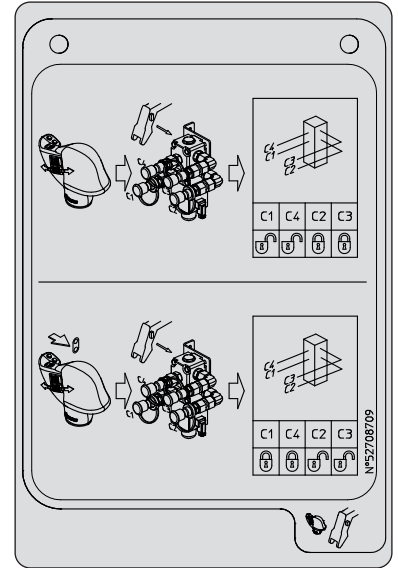

OPENED CAB

ATTACHMENT LINE CONTROL "C1-C4"

- Push switch 1 forward or backward to control the attachment line "C1-C4".

ATTACHMENT LINE CONTROL "C2-C3"

- Hold down button 2 and push switch 1 forward or backward to control the attachment line "C2-C3".

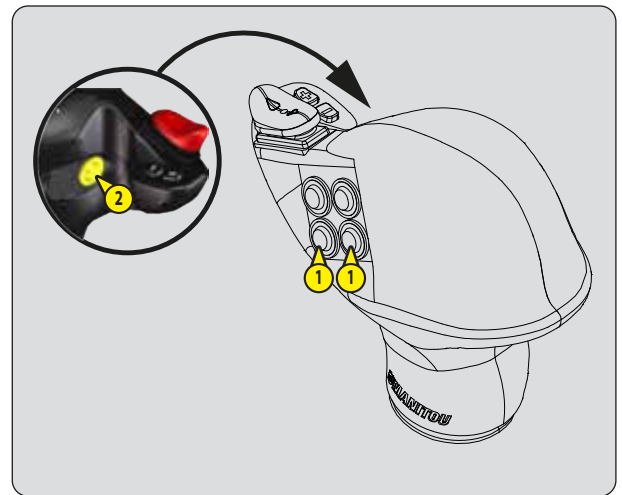

CLOSED CAB

ATTACHMENT LINE CONTROL "C1-C4"

- Push switch 1 forward or backward to control the attachment line "C1-C4".

ATTACHMENT LINE CONTROL "C2-C3"

- Hold down button 2 and push switch 1 forward or backward to control the attachment line "C2-C3".

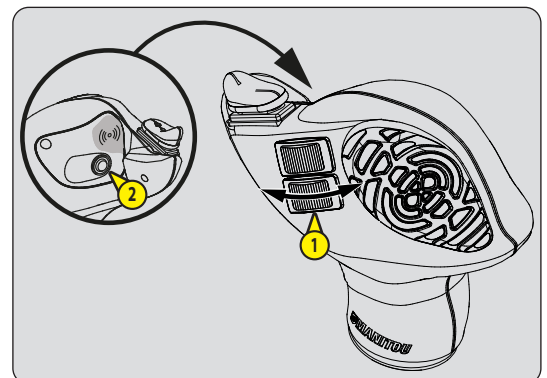

5 - HIGH FLOW HYDRAULIC CIRCUIT

For the hydraulic pump specifications (↩ - SPECIFICATIONS).





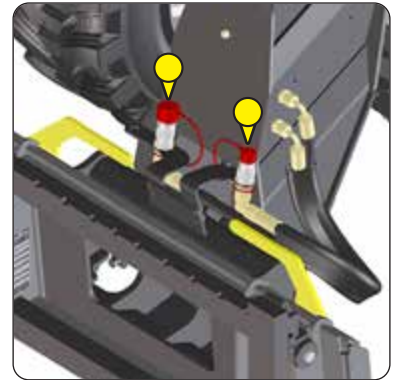

6 - HYDRAULIC ATTACHMENT LINE "TSS"



7 - ATTACHMENT CIRCUIT FLOW RATE LIMITER

FLOW RATE MEMORIZATION

- Hold down the  button;  will appear on the information screen.
- Press buttons   to set the flow rate.
- Press knob  to confirm.

ACTIVATING THE MEMORIZED FLOW RATE

- Press the  button to activate. The indicator light will come on, showing that it is in use.
- Press the button again to deactivate.

8 - EXTERIOR DRAIN-BACK

Enables connection of an attachment for which drain-back to the hydraulic tank is required.





9 - BOOM HEAD ELECTROVALVE - ONE HYDRAULIC FUNCTION + HYDRAULIC ATTACHMENT LOCKING

Enables use of two hydraulic functions on the attachment circuit.

ATTACHMENT EASY HYDRAULIC CONNECTION

For easy connection and disconnection of hydraulic attachments.

PREFERENCES MENU BUTTON OPERATION

- Switch on the machine's ignition.
- Press the button  to display the "PREFERENCES" menu.
- Press the button  to select from the menus and sub-menus.

HYDRAULICS > EASY CONNECT SYSTEM

- Press knob  to confirm.
- Follow the steps described on the information screen. Operation is confirmed by two hazard warning lights being activated.
- Connect or disconnect the rapid connectors of the hydraulic attachment (4 - ATTACHMENTS: PICKING UP THE ATTACHMENTS).

⚠ IMPORTANT ⚠

After locking the attachment, turn off the switch  (indicator lamp off) to prevent accidental unlocking of the attachment.

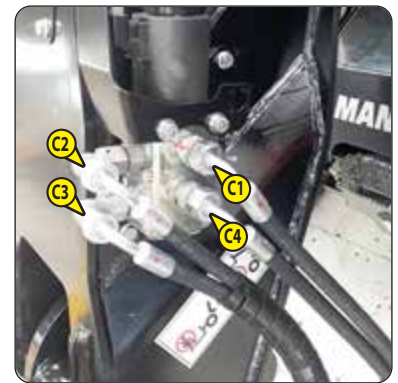
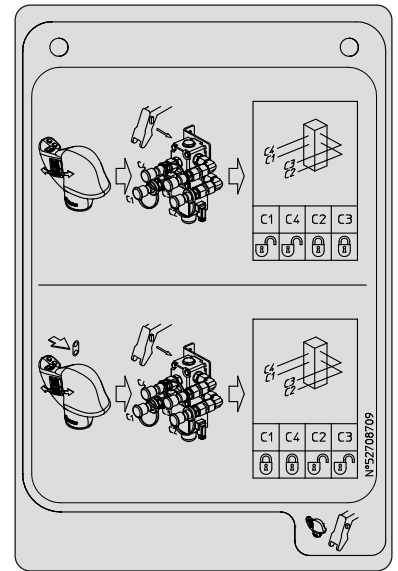

OPENED CAB

ATTACHMENT LINE CONTROL "C1-C4"

- Push switch 1 forward or backward to control the attachment line "C1-C4".

ATTACHMENT LOCKING CONTROL "C2-C3"

- Hold down button 2 and push button 1 forward to lock the attachment and backward to release it.
- Release knobs 1 and 2.

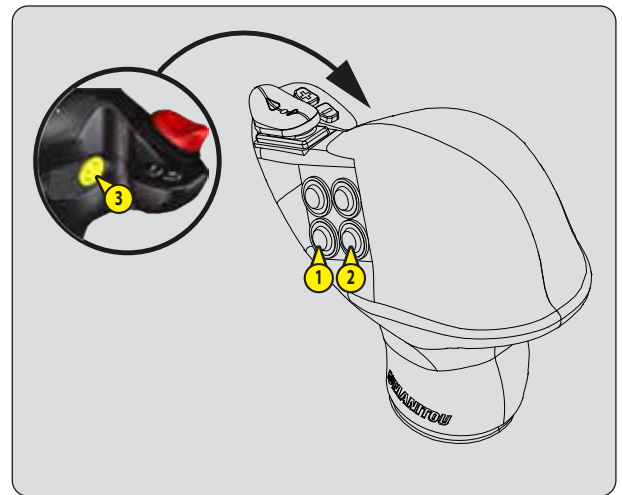

CLOSED CAB

ATTACHMENT LINE CONTROL "C1-C4"

- Push switch 1 forward or backward to control the attachment line "C1-C4".

ATTACHMENT LOCKING CONTROL "C2-C3"

- Hold down button 2 and push button 1 forward to lock the attachment and backward to release it.
- Release knobs 1 and 2.

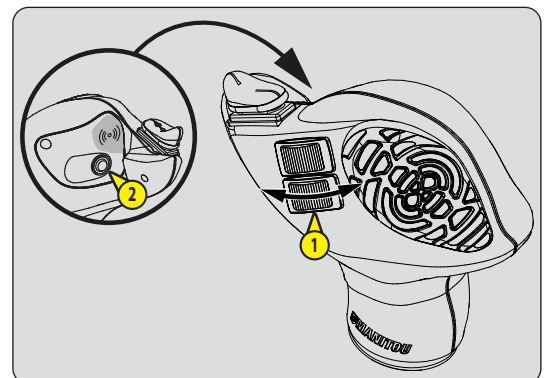

10 - BOOM ELECTRICAL PREDISPOSITION

Enables an electrical function to be used at the boom head.

OPERATION

- Press the switch. The indicator  will come on when the function is enabled.



11 - LIFTING RING ON CARRIAGE

CONDITIONS OF USE AND FUNCTION SHEET

⚠ IMPORTANT ⚠

Follow the instructions given in the instruction manual (↖ 1 - OPERATING AND SAFETY INSTRUCTIONS: INSTRUCTIONS ON HANDLING LOADS), in addition to those given below.

- The lifting ring must be used WITHOUT FORKS AND ATTACHMENTS, but the angle of inclination of the carriage must be same as when the forks are used in the horizontal position.
- Check the maximum permitted angle, which is 45°.
- Do not change the angle of the carriage while using the lifting ring.
- The lifting hook, the chains and slings shall have a minimum capacity of 3000 kg with a safety coefficient of 4 in relation to breakage.

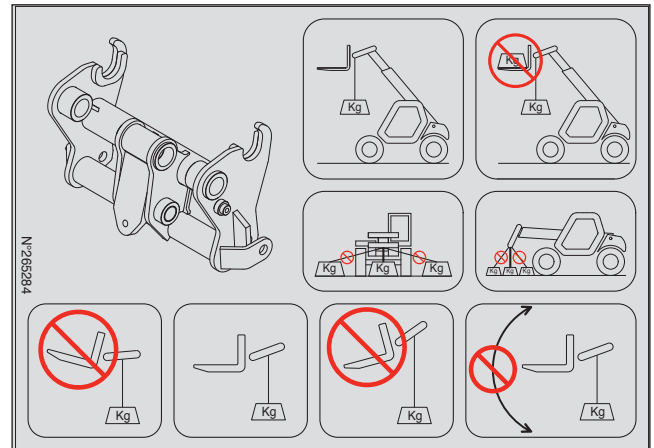

12 - MATERIAL DEFLECTOR ON BOOM HEAD



OPTIONS - LIGHTS

1 - FRONT AND REAR ROAD LIGHTING	2-68
2 - FRONT WORKLIGHTS	2-69
3 - REAR WORKLIGHTS	2-69
4 - WORKING LIGHTS ON BOOM HEAD	2-69
5 - BLUE POULTRY FARMING WORKLIGHTS	2-69

1 - FRONT AND REAR ROAD LIGHTING

FRONT HEADLIGHTS

- A - Right front high beam headlight and turn signal.
- B - Right front low beam and position light.
- C - Left front low beam headlight and position light.
- D - Left front high beam headlight and turn signal.



REAR LIGHTS

- A - Left rear light (rear light, stop light and turn signal).
- B - Fog light.
- C - Right rear light (rear light, stop light and turn signal).
- D - Reversing light.



The switch controls the visual and sound alarms.

- A - All lights are off, the turn signals do not flash.
- B - The right-hand turn signals flash.
- C - The left-hand turn signals flash.
- D - The sidelights and rear lights are on.
- E - The dipped beam headlights and rear lights are on.
- F - The main beam headlights and rear lights are on.
- G - Headlight signaling.

Pressing the end of the switch sounds the horn.

NOTE: Positions D - E - F - G can be used without switching on the ignition.

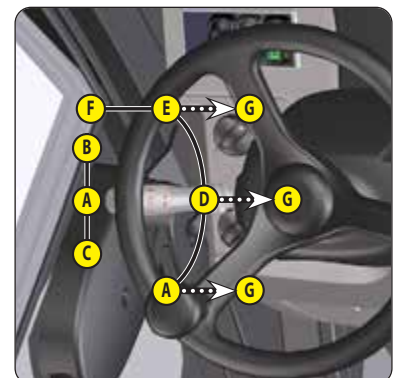

2 - FRONT WORKLIGHTS

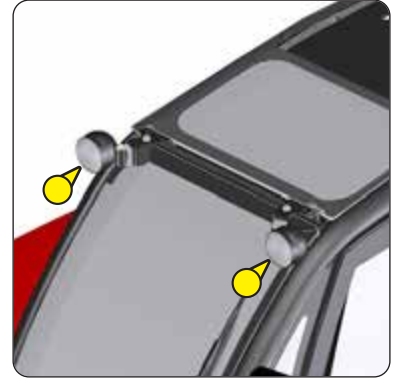

3 - REAR WORKLIGHTS



4 - WORKING LIGHTS ON BOOM HEAD

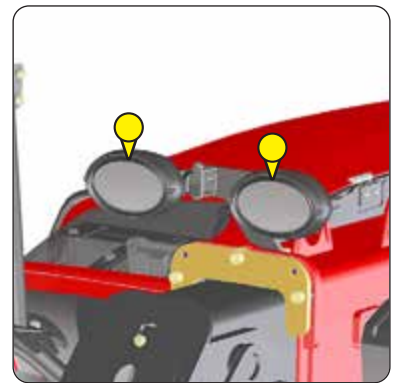

5 - BLUE POULTRY FARMING WORKLIGHTS



OPTIONS - CHASSIS

1 - REAR ELECTRIC SOCKET	2-71
2 - CLEVIS HITCH	2-71
3 - REAR MUDGUARD.....	2-71

1 - REAR ELECTRIC SOCKET

- Connect the male plug to the female socket 1 on the machine and make sure the lights of the trailer or the light bar are working properly.



2 - CLEVIS HITCH

⚠ IMPORTANT ⚠

Be careful not to get your fingers caught or crushed during this operation.

Do not forget to put the cotter pin back in place.

When uncoupling, make sure that the trailer is supported independently

COUPLING AND UNCOUPLING THE TRAILER

- To couple the trailer, position the machine as close as possible to the trailer ring.
- Activate the parking brake and switch off the engine.
- Remove the pin 1, lift the towing pin 2 and place or remove the trailer ring.



3 - REAR MUDGUARD



OPTIONS - SAFETY

1 - ANGULAR SECTOR ON BOOM	2-72
2 - "A-B-C-D-E" MARKING ON BOOM	2-72
3 - FRONT AND REAR CAMERAS	2-73
4 - COMPACT LED ROTATING BEACON LIGHT	2-73
5 - REFLECTIVE BANDS	2-74
6 - WINDSHIELD GRILLE (CLOSED CAB).....	2-74
7 - DOOR WINDOW ANTI-BREACH BAR (CLOSED CAB).....	2-74
8 - LICENSE PLATE LIGHT	2-74
9 - ATTACHMENT CIRCUIT LOCKING	2-74
10 - KEY-LOCKED FUEL TANK CAP	2-75
11 - KEYPAD "EasyMANAGER".....	2-75
12 - WHEEL CHOCK.....	2-75
13 - DOUBLE INCLINOMETER.....	2-75
14 - REAR PARKING AID.....	2-76
15 - FLASHING LIGHT.....	2-76
16 - RED ROTATING BEACON LIGHT	2-76
17 - GREEN ROTATING BEACON LIGHT (UK ONLY).....	2-76
18 - SAFETY LOGIC DESCRIPTION.....	2-77

1 - ANGULAR SECTOR ON BOOM

The angular sector displays the boom angle, and thus improves the reading of the load charts.

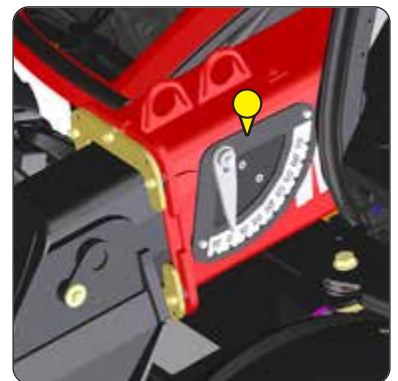

2 - "A-B-C-D-E" MARKING ON BOOM

The marking indicates the outreach of the boom and therefore improves reading of the load charts.

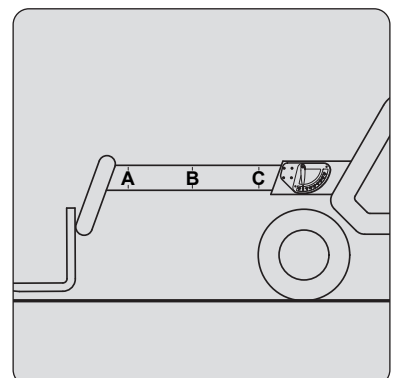

3 - FRONT AND REAR CAMERAS

The front and rear cameras can be configured in manual or automatic mode.

START UP

- Turn the monitor 1 on by pressing "POWER". The green indicator light should come on.

NOTE: If the monitor does not display the camera image, press "SEL" repeatedly to select another camera input until an image appears on the monitor.

- Navigate through the monitor menus to set up the monitor.

A - Turn the monitor on/off.

B - Decrease the screen brightness.

C - Increase the screen brightness.

D - Displays guidance superimposed on the camera view.

E - Displays the following menus as you press in turn:

- Image: brightness / contrast / color / volume
- Option: camera 1 / camera 2 / camera 3. This menu is used to display the mirror image as seen in a rearview mirror.
- System: language, resolution, blue background, darken, distance marker.
- Auto-scan: autoscan, scan time, cam1, cam2, cam3.
- Scale: cam1, cam2, cam3, cam1 scale, cam2 scale, cam3 scale.

F - Selects the desired camera input.

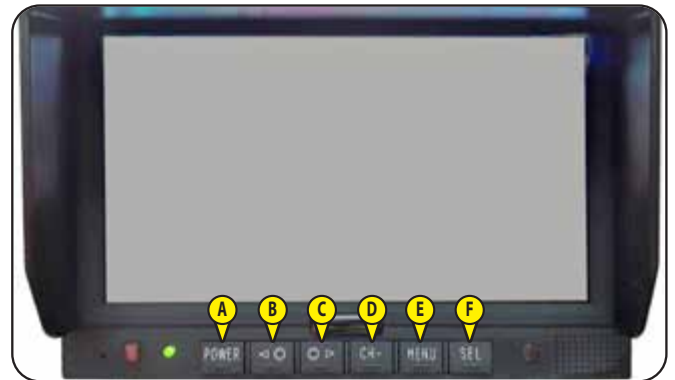

4 - COMPACT LED ROTATING BEACON LIGHT

The magnetic rotating beacon light must be clearly visible on the roof of the cab and plugged in to 12 V socket 1.

◀ PUSH BUTTON PANEL

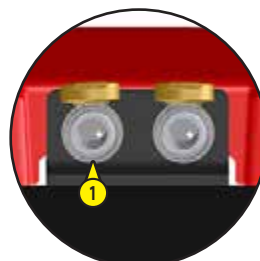

5 - REFLECTIVE BANDS



6 - WINDSHIELD GRILLE (CLOSED CAB)

The windshield grille provides additional protection for the operator from any external elements spattered on the windshield.



7 - DOOR WINDOW ANTI-BREACH BAR (CLOSED CAB)



8 - LICENSE PLATE LIGHT

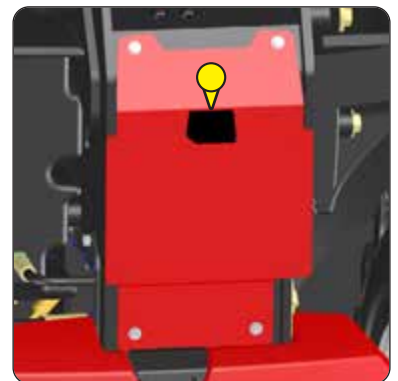

9 - ATTACHMENT CIRCUIT LOCKING

- Press the  button to shut off the attachment circuit hydraulic movements. The indicator lamp indicates it is in use.



10 - KEY-LOCKED FUEL TANK CAP

- The key for the fuel tank cap is standard.



11 - KEYPAD "EasyMANAGER"

A code must be created for the operator via the "EasyMANAGER" portal. For more information, contact your dealer.

OPERATION

BY ID CODE

- Switch on the machine's ignition. LED 1 comes on.
- Enter your ID code and confirm by pressing the "V" key.
- LED 2 comes on to confirm the operator's identification.
- Immediately start the machine, otherwise the identification process is canceled and LED 2 turns red.

NOTE: In case of an input error, LED 2 lights up red, press the "X" key, and wait 10 seconds before entering the correct identification code.

BY ID CARD

- Switch on the machine's ignition. LED 1 comes on.
- Present your ID card; an audible beep confirms that the card has been read.
- LED 2 comes on to confirm the operator's identification.
- Immediately start the machine, otherwise the identification process is canceled and LED 2 turns red.



12 - WHEEL CHOCK

The wheel chock serves as an additional safety device in case of a breakdown.



13 - DOUBLE INCLINOMETER



14 - REAR PARKING AID

Progressive visual and audible alarm.

- 2M50 to 1M00 => 1 light bar + 1 beep intermittently.
- 1M00 to 0M60 => 4 light bars + 4 beeps intermittently.
- 0M60 to 0M00 => 7 light bars + continuous beep.



15 - FLASHING LIGHT

SAFETY LOGIC DESCRIPTION



16 - RED ROTATING BEACON LIGHT

The magnetic rotating beacon light must be clearly visible on the roof of the cab and plugged in to 12 V socket 1.

- SAFETY LOGIC DESCRIPTION



17 - GREEN ROTATING BEACON LIGHT (UK ONLY)











The magnetic rotating beacon light must be clearly visible on the roof of the cab and plugged in to 12 V socket 1.

The rotating beacon light indicates the driver's presence in the seat.

- SAFETY LOGIC DESCRIPTION



18 - SAFETY LOGIC DESCRIPTION

	Dashboard warning message.
	Machine travel (km/h).
	Cab door.
	Boom angle.
	Seat belt
	Presence of driver on seat.
	Machine lateral angle.
	Rear axle offloading + deactivation of "aggravating" hydraulic movement cut-off
	Cab flashing light + red rotating beacon light.
	Permanently

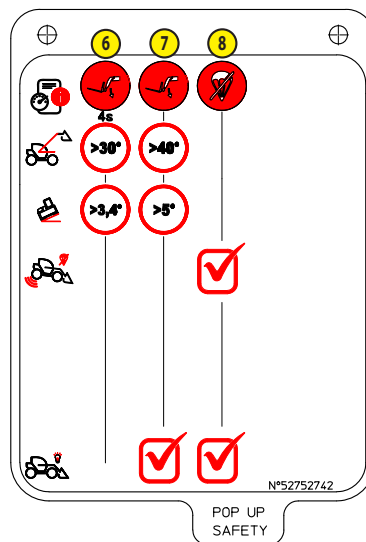
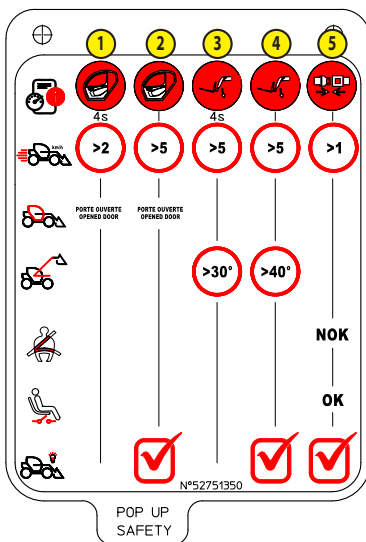

- ① => Risky driving - Close the door
- ② => Risky driving - Close the door
- ③ => Risky driving - Lower the boom
- ④ => Risky driving - Lower the boom
- ⑤ => Risky driving - Put on the seat belt
- ⑥ => Risky driving - Lower the boom
- ⑦ => Risky driving - Lower the boom
- ⑧ => Stability system deactivation

3 - MAINTENANCE

3 - MAINTENANCE

ORIGINAL MANITOU SPARE PARTS AND EQUIPMENT	3-3
MACHINE MAINTENANCE	3-4
DAILY AND WEEKLY MAINTENANCE	3-4
MANDATORY FIRST 500 HOURS OR 6 MONTHS OF SERVICE	3-5
PERIODIC MAINTENANCE	3-6
OCCASIONAL MAINTENANCE AND OPERATION	3-8
LUBRICANTS AND FUEL	3-10
➤ 10H - DAILY SERVICE OR EVERY 10 HOURS OF SERVICE	3-12
➤ 50H - WEEKLY MAINTENANCE OR EVERY 50 HOURS OF SERVICE	3-14
➤ ① 250H - PERIODIC MAINTENANCE - EVERY 250 HOURS OF SERVICE	3-20
➤ ② 500H - PERIODIC MAINTENANCE - EVERY 500 HOURS OF SERVICE OR 1 YEAR	3-22
➤ ③ 1000H - PERIODIC MAINTENANCE - EVERY 1,000 HOURS OF SERVICE OR 2 YEARS	3-26
➤ ④ 1500H - PERIODIC MAINTENANCE - EVERY 1500 HOURS OF SERVICE OR 3 YEARS	3-30
➤ ⑤ 2000H - PERIODIC MAINTENANCE - EVERY 2,000 HOURS OF SERVICE OR EVERY 4 YEARS	3-32
➤ ⑥ 3000H - PERIODIC MAINTENANCE - EVERY 3,000 HOURS OF SERVICE OR EVERY 6 YEARS	3-34
➤ OCCASIONAL MAINTENANCE	3-36
➤ OCCASIONAL OPERATION	3-42

ORIGINAL MANITOU SPARE PARTS AND EQUIPMENT

OUR MACHINES MUST BE SERVICED USING ORIGINAL MANITOU PARTS.

BY ALLOWING THE USE OF NON ORIGINAL MANITOU PARTS, YOU RISK:

⚠ IMPORTANT ⚠

THE USE OF COUNTERFEIT PARTS OR COMPONENTS NOT APPROVED BY THE MANUFACTURER MEANS YOU LOSE THE BENEFIT OF THE CONTRACTUAL GUARANTEE.

- Legally, incurring liability in the event of an accident.
- Technically, causing operating malfunctions and reducing the machine's service life.

BY USING ORIGINAL MANITOU PARTS FOR MAINTENANCE OPERATIONS, YOU BENEFIT FROM OUR KNOW-HOW

Through its network, MANITOU provides the user with,

- Know-how and competence.
- The guarantee of high-quality work.
- Original replacement parts.
- Help with preventive maintenance.
- Efficient help with diagnosis.
- Improvements as a result of feedback.
- Operator training.
- Only the MANITOU network has detailed knowledge of the design of the machine and therefore the best technical ability to provide maintenance.

⚠ IMPORTANT ⚠

ORIGINAL REPLACEMENT PARTS ARE DISTRIBUTED EXCLUSIVELY BY MANITOU AND ITS DEALER NETWORK.

The dealer network list is available on the MANITOU web site: www.manitou.com

MACHINE MAINTENANCE

DAILY AND WEEKLY MAINTENANCE



THE OPERATOR IS AUTHORIZED TO CARRY OUT THIS MAINTENANCE.

This maintenance enables the operator to keep the machine in a clean and safe condition.

MANDATORY FIRST 500 HOURS OR 6 MONTHS OF SERVICE



THIS SERVICE MUST BE CARRIED OUT AFTER THE FIRST 500 HOURS OF SERVICE OR WITHIN THE 6 MONTHS FOLLOWING THE START-UP OF THE MACHINE (WHICHEVER OCCURS FIRST).

PERIODIC MAINTENANCE



THE PERIODIC MAINTENANCE MUST BE CARRIED OUT BY A PROFESSIONAL APPROVED BY THE MANITOU NETWORK

MAINTENANCE SCHEDULE

This schedule enables the operator to keep the periodic maintenance on the machine up-to-date by reporting the total number of hours worked and the date of the service carried out by the professional approved by the MANITOU network.

OCCASIONAL MAINTENANCE AND OPERATION

These maintenance operations are to be carried out when needed for the safety and upkeep of the machine.

DAILY AND WEEKLY MAINTENANCE

↻ 10H - DAILY SERVICE OR EVERY 10 HOURS OF SERVICE

- CHECK	Machine environment.....	3-12
- CHECK	Engine oil level.....	3-12
- CHECK	Coolant level.....	3-12
- CHECK	Water separator.....	3-13
- CHECK	Longitudinal stability limiter and warning device.....	3-13
- CLEAN	Cyclonic pre-filter (OPTION).....	3-13

↻ 50H - WEEKLY MAINTENANCE OR EVERY 50 HOURS OF SERVICE

- CHECK	Alternator belt tension *.....	3-14
	<i>* Only for the first 50 hours of service, and then every 250 hours of service.</i>	
- CHECK	Air conditioning compressor belt tension (OPTION) *.....	3-14
	<i>* Only for the first 50 hours of service, and then every 250 hours of service.</i>	
- CHECK	Transfer box seal.....	3-14
- CHECK	Front axle differential seal.....	3-14
- CHECK	Rear axle differential seal.....	3-14
- CHECK	Front wheel reducer seals.....	3-15
- CHECK	Rear wheel reducer seals.....	3-15
- CHECK	Tire pressure.....	3-15
- CHECK	Wheel nut tightening.....	3-15
- CHECK	Brake fluid level.....	3-15
- CHECK	Boom pad slide pathways.....	3-15
- CHECK	Hydraulic fluid level.....	3-16
- CHECK	Windshield washer liquid level (OPTION).....	3-16
- CLEAN	Radiator cores.....	3-16
- CLEAN	Dry air filter cartridge.....	3-17
- CLEAN	Condenser core (OPTION).....	3-17
- CLEAN	Fan.....	3-17
- LUBRICATE	General lubrication.....	3-17
- BLEED	Water separator.....	3-19

MANDATORY FIRST 500 HOURS OR 6 MONTHS OF SERVICE

FIRST 500 HOURS BEFORE THE FIRST 6 MONTHS

- If the machine has reached the first 500 hours of service before the first 6 months have expired, perform both the mandatory service and periodic 500 H service (◀ ▶ ① 500H - EPERIODIC SERVICE - EVERY 500 HOURS OF SERVICE OR 1 YEAR).

FIRST 6 MONTHS BEFORE THE FIRST 500 HOURS

- If the machine has not completed 500 hours of service in the first 6 months, carry out only the mandatory service.

MANDATORY SERVICE

- CHECK	Alternator belt tension *	3-14
- CHECK	Air conditioning compressor belt tension (OPTION) *	3-14
- CHECK	Transfer box seal	3-14
- CHECK	Front axle differential seal	3-14
- CHECK	Rear axle differential seal	3-14
- CHECK	Front wheel reducer seals	3-15
- CHECK	Rear wheel reducer seals	3-15
- CHECK	Tire pressure	3-15
- CHECK	Wheel nut tightening	3-15
- CHECK	Brake fluid level	3-15
- CHECK	Boom pad slide pathways	3-15
- CHECK	Hydraulic fluid level	3-16
- CHECK	Windshield washer liquid level (OPTION)	3-16
- CLEAN	Radiator cores	3-16
- CLEAN	Dry air filter cartridge	3-17
- CLEAN	Condenser core (OPTION)	3-17
- CLEAN	Fan	3-17
- LUBRICATE	General lubrication	3-17
- BLEED	Water separator	3-19
- CHECK	Alternator belt tension	3-20
- CHECK	Air conditioning compressor belt tension (OPTION)	3-21
- CHECK	Fork wear *	3-25
- CHECK	Air intake line and air suction hose *	3-25
- CHECK	Seat belt	3-26
- CHECK	Silentblocks **	3-29
- CHECK	Valve lash **	3-29
- CHECK	Injection pipes, fuel hoses and hose clamps **	3-29
- CHECK	Boom pad wear *	3-29
- CHECK	Condition of wiring harnesses and cables *	3-29
- CHECK	Lights and signals *	3-29
- CHECK	Horns *	3-29
- CHECK	Condition of the rear view mirrors *	3-29
- CHECK	Cab structure *	3-29
- CHECK	Structure of the chassis *	3-29
- CHECK	Attachment mounting system *	3-29
- CHECK	Condition of attachments *	3-29
		* Consult your dealer.
		** Engine service, consult your dealer.
- REPLACE	Transfer box oil	3-30
- REPLACE	Front axle differential oil	3-30
- REPLACE	Rear axle differential oil	3-30
- REPLACE	Front wheel reducer oil	3-30
- REPLACE	Rear wheel reducer oil	3-30
- CHECK	Parking brake pad wear *	3-33
- CHECK	Service brake pad wear *	3-33
- CHECK	Brake disc wear *	3-33

PERIODIC MAINTENANCE

MAINTENANCE SCHEDULE

		↻ OR ↻				
SCHEDULE ↻	250 H	FIRST 6 MONTHS	FIRST 500 HOURS	500 H or 1 YEAR	750 H	1000 H or 2 YEARS
PERIODIC MAINTENANCE ↻	①	MANDATORY SERVICE	MANDATORY SERVICE + ②	① + ②	①	① + ② + ③
MACHINE COUNTER ↻						
DATE OF SERVICING ↻						

SCHEDULE ↻	1250 H	1500 H or 3 YEARS	1750 H	2000 H or 4 YEARS	2250 H	2500 H or 5 YEARS	2750 H
PERIODIC MAINTENANCE ↻	①	① + ② + ④	①	① + ② + ③ + ⑤	①	① + ②	①
MACHINE COUNTER ↻							
DATE OF SERVICING ↻							

SCHEDULE ↻	3000 H or 6 YEARS	3250 H	3500 H or 7 YEARS	3750 H	4000 H or 8 YEARS	4250 H	4500 H or 9 YEARS
PERIODIC MAINTENANCE ↻	① + ② + ③ + ④ + ⑥	①	① + ②	①	① + ② + ③ + ⑤	①	① + ②
MACHINE COUNTER ↻							
DATE OF SERVICING ↻							

SCHEDULE ↻	4750 H	5000 H or 10 YEARS	5250 H	5500 H or 11 YEARS	5750 H	6000 H or 12 YEARS	6250 H
PERIODIC MAINTENANCE ↻	①	① + ② + ③	①	① + ②	①	① + ② + ③ + ④ + ⑥	①
MACHINE COUNTER ↻							
DATE OF SERVICING ↻							

SCHEDULE ↻	6500 H or 13 YEARS	6750 H	7000 H or 14 YEARS	7250 H	7500 H or 15 YEARS	7750 H	8000 H or 16 YEARS
PERIODIC MAINTENANCE ↻	① + ②	①	① + ② + ③	①	① + ②	①	① + ② + ③ + ⑤
MACHINE COUNTER ↻							
DATE OF SERVICING ↻							

➔ ① 250H - PERIODIC MAINTENANCE - EVERY 250 HOURS OF SERVICE

- CHECK	Alternator belt tension	3-20
- CHECK	Air conditioning compressor belt tension (OPTION)	3-21

➔ ② 500H - PERIODIC MAINTENANCE - EVERY 500 HOURS OF SERVICE OR 1 YEAR

ALSO CARRY OUT THE PERIODIC MAINTENANCE FOR 250 HOURS OF SERVICE.

- CHECK	Hydraulic oil	3-22
- REPLACE	Engine oil	3-22
- REPLACE	Engine oil filter	3-22
- REPLACE	Water separator cartridge	3-23
- REPLACE	Fuel filter	3-24
- REPLACE	Hydraulic return oil filter cartridge	3-24
- REPLACE	Cab fan filter	3-25
- CHECK	Fork wear *	3-25
- CHECK	Air intake line and air suction hose *	3-25

*** Consult your dealer.**

➔ ③ 1000H - PERIODIC MAINTENANCE - EVERY 1,000 HOURS OF SERVICE OR 2 YEARS

ALSO CARRY OUT THE PERIODIC MAINTENANCE FOR 500 HOURS OF SERVICE.

- CHECK	Seat belt	3-26
- CLEAN	Fuel tank	3-26
- REPLACE	Fuel tank breather	3-26
- REPLACE	Dry air filter cartridge	3-27
- REPLACE	Coolant	3-28
- CHECK	Silentblocks **	3-29
- CHECK	Valve lash **	3-29
- CHECK	Injection pipes, fuel hoses and hose clamps **	3-29
- CHECK	Hoses and hose clamps for the coolant radiator **	3-29
- CHECK	Lubrication hoses **	3-29
- CHECK	Brake system pressure *	3-29
- CHECK	Boom pad wear *	3-29
- CHECK	Condition of wiring harnesses and cables *	3-29
- CHECK	Lights and signals *	3-29
- CHECK	Horns *	3-29
- CHECK	Condition of the rear view mirrors *	3-29
- CHECK	Cab structure *	3-29
- CHECK	Structure of the chassis *	3-29
- CHECK	Attachment mounting system *	3-29
- CHECK	Condition of attachments *	3-29
- REPLACE	Brake fluid *	3-29

*** Consult your dealer.**

**** Engine service, consult your dealer.**

➔ ④ 1500H - PERIODIC MAINTENANCE - EVERY 1500 HOURS OF SERVICE OR 3 YEARS

ALSO CARRY OUT THE PERIODIC MAINTENANCE FOR 500 HOURS OF SERVICE.

- CHECK	Air circulation system in the engine crankcase **	3-30
		** Engine service, consult your dealer.
- REPLACE	Transfer box oil	3-30
- REPLACE	Front axle differential oil	3-30
- REPLACE	Rear axle differential oil	3-30
- REPLACE	Front wheel reducer oil	3-30
- REPLACE	Rear wheel reducer oil	3-30

5 2000H - PERIODIC MAINTENANCE - EVERY 2,000 HOURS OF SERVICE OR EVERY 4 YEARS

ALSO PERFORM THE 500-HOUR AND 1,000-HOUR PERIODIC MAINTENANCE PROCEDURES.

- CHECK	Wheel nut tightening torque	3-32
- REPLACE	Dry air filter safety cartridge	3-32
- REPLACE	Hydraulic oil	3-32
- CLEAN	Hydraulic oil tank suction strainer	3-32
- CHECK	Clearance of valve seats **	3-33
- CHECK	Radiator *	3-33
- CHECK	Transmission pressures *	3-33
- CHECK	Steering *	3-33
- CHECK	Steering swivel joints *	3-33
- CHECK	Parking brake pad wear *	3-33
- CHECK	Service brake pad wear *	3-33
- CHECK	Brake disc wear *	3-33
- CHECK	Condition of boom assembly *	3-33
- CHECK	Bearings and bushings *	3-33
- CHECK	Condition of hoses and flexible pipes *	3-33
- CHECK	Condition of cylinders (leakage, rods) *	3-33
- CHECK	Hydraulic circuit pressures *	3-33
- CLEAN	Air conditioning (OPTION) *	3-33

* Consult your dealer.

** Engine service, consult your dealer.

6 3000H - PERIODIC MAINTENANCE - EVERY 3,000 HOURS OF SERVICE OR EVERY 6 YEARS

ALSO PERFORM THE 500-HOUR AND 1,000-HOUR PERIODIC MAINTENANCE PROCEDURES.

- CHECK	Engine ECU (ECU) and associated sensors and actuators **	3-34
- CHECK	Diesel oxidation catalyst (DOC) of the diesel particulate filter (DPF) **	3-34
- CHECK	Intake valve **	3-34
- CHECK	Exhaust valve **	3-34
- CHECK AND CLEAN	Exhaust gas recirculation system valve (EGR) **	3-34
- CHECK AND CLEAN	Injectors **	3-34
- CLEAN	Exhaust gas recirculation system cooler (EGR) **	3-34

** Engine service, consult your dealer.

OCCASIONAL MAINTENANCE AND OPERATION

OCCASIONAL MAINTENANCE

- CLEAN	"Stationary machine" exhaust regeneration	3-36
- REPLACE	Wheels	3-37
- REPLACE	Battery	3-38
- BLEED	Fuel supply circuit	3-39
- RESET	Longitudinal stability limiter and warning device	3-39
- CHECK	Disabling "AGGRAVATING" hydraulic movement cut-off	3-40

OCCASIONAL OPERATION

- TOW/WINCH	Machine	3-42
- SLING	Machine	3-43
- TRANSPORT	Machine on a truck deck	3-43
- TRANSPORT	Machine on a low-bed trailer	3-44

LUBRICANTS AND FUEL

⚠ IMPORTANT ⚠

USE THE RECOMMENDED LUBRICANTS AND FUEL:

- For topping up, oils may not be miscible.
- For oil changes, MANITOU oils are perfectly appropriate.

DIAGNOSTIC ANALYSIS OF OILS

If a service or maintenance contract has been set up with the dealer, a diagnostic analysis of engine, transmission and axle oils may be requested depending on the rate of use.

(*) REQUIRED FUEL SPECIFICATION

Use a high-quality fuel to obtain optimal performance of the engine.

- EN590 diesel fuel (sulfur content < 10 ppm)
- Type of diesel fuel ASTM D975 (sulfur content < 15 ppm)

RECOMMENDATION

ENGINE		RECOMMENDATION										
DESCRIPTION	CAPACITY	-40°C	-30	-20	-10	0	+10	+20	+30	+40	+50°C	
ENGINE OIL	6,7 ℓ	5W30										
		10W30										
		MANITOU OIL EVOLOGY 10W40 API CJ4										
		15W40										
COOLING CIRCUIT	6 ℓ	COOLANT -35°C										
FUEL TANK	35 ℓ	DIESEL GNR HP (*)										
BOOM		RECOMMENDATION										
DESCRIPTION		-40°C	-30	-20	-10	0	+10	+20	+30	+40	+50°C	
BOOM PAD SLIDE PATHWAYS		MANITOU BLACK MULTI-PURPOSE LUBRICANT										
GREASING OF THE BOOM		MANITOU BLUE MULTI-PURPOSE LUBRICANT										
HYDRAULICS		RECOMMENDATION										
DESCRIPTION	CAPACITY	-40°C	-30	-20	-10	0	+10	+20	+30	+40	+50°C	
HYDRAULIC OIL TANK	39 ℓ	ISO VG 100										
		ISO VG 68										
		MANITOU HYDRAULIC OIL ISO VG 46										
		ISO VG 37										
		ISO VG 32										
BRAKES		RECOMMENDATION										
DESCRIPTION	CAPACITY											
BRAKE SYSTEM	1 ℓ	MANITOU MINERAL BRAKE FLUID										
CAB		RECOMMENDATION										
DESCRIPTION	CAPACITY											
WINDSHIELD WASHER TANK	1,25 ℓ	WINDSHIELD WASHER FLUID										
FRONT AXLE		RECOMMENDATION										
DESCRIPTION	CAPACITY	-40°C	-30	-20	-10	0	+10	+20	+30	+40	+50°C	
FRONT AXLE DIFFERENTIAL	3,7 ℓ	MANITOU OIL SAE80W90 MECHANICAL TRANSMISSION										
TRANSFER GEAR BOX	0,6 ℓ											
FRONT WHEEL REDUCING GEAR	2 x 0,5 ℓ											

REAR AXLE		RECOMMENDATION									
DESCRIPTION	CAPACITY	-40°C	-30	-20	-10	0	+10	+20	+30	+40	+50°C
REAR AXLE DIFFERENTIAL REAR WHEEL REDUCING GEAR	3,7 ℓ 2 x 0,5 ℓ	MANITOU SAE80W90 MECHANICAL TRANSMISSION OIL									
REAR AXLE OSCILLATION		MANITOU BLUE MULTI-PURPOSE LUBRICANT									

PACKAGING

OIL						
PRODUCT	PACKAGING / REFERENCE					
	1 ℓ	2 ℓ	5 ℓ	20 ℓ	55 ℓ	209 ℓ
- MANITOU OIL EVOLOGY 10W40 API CJ4			895837	895838	895839	895840
- MANITOU HYDRAULIC OIL ISO VG 46			545500	582297	546108	546109
- MANITOU MINERAL BRAKE FLUID	490408					4500078
- MANITOU OIL SAE80W90 MECHANICAL TRANSMISSION		499237	720184	546330	546221	546220

GREASE						
PRODUCT	PACKAGING / REFERENCE					
	400 mℓ	400 g	1 kg	5 kg	20 kg	50 kg
- MANITOU BLACK MULTI-PURPOSE LUBRICANT		947766	161590			499235
- MANITOU BLUE MULTI-PURPOSE LUBRICANT		161589		554974	499233	489670

LIQUID						
PRODUCT	PACKAGING / REFERENCE					
	1 ℓ	2 ℓ	5 ℓ	20 ℓ	55 ℓ	210 ℓ
- COOLANT -35°C			894967	894968		894969
- WINDSHIELD WASHER FLUID	490402		486424			

CHECK

Machine environment

Carry out a general inspection around the machine:

- Fluid leaks or stains on the ground.
- Additional objects on the machine and in the cab.
- Mounting and locking of the attachment.
- Mounting and adjustment of rear-view mirrors.
- Condition of the tires, to detect cuts, blisters, wear, etc.

⚠ IMPORTANT ⚠

Follow the operator instructions (➤ 1 - OPERATING AND SAFETY INSTRUCTIONS: OPERATOR INSTRUCTIONS).

CLEANLINESS OF THE MACHINE

- Cleanliness of lights and rear-view mirror.
- Excess dirt or build-up of material (e.g. straw, flour, sawdust, organic waste, etc.).
- On a daily basis, according to the conditions of use and the environment, the operator should ensure that the machine is kept in a clean condition.
- Particular attention should be paid to accumulations of flammable materials (e.g. straw, flour, sawdust, organic waste, etc.) and fuel or lubricant leaks, as these significantly increase the risk of fire outbreaks.
- A regular inspection of the whole machine, especially the engine housing and the central part of the chassis, is necessary to see how frequently it needs to be cleaned to prevent these potential accumulations of material or leakages.

CHECK

Engine oil level

Set the machine on level ground with the engine off and let the oil drain into the sump.

- Open the engine hood.
- Pull out the dipstick 1.
- Clean the dipstick and check the correct level between the two notches.
- If necessary, add oil (➤ LUBRICANTS AND FUEL) through one of the filler holes 2.
- Visually check that there is no leakage or seepage.

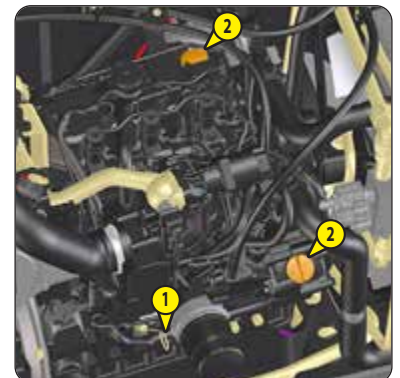

CHECK

Coolant level

Set the machine on level ground with the engine off and wait for the engine to cool down.

⚠ IMPORTANT ⚠

To avoid any risk of spraying or scalding, wait until the engine has cooled down before removing the cooling circuit filler plug.

If the cooling liquid is very hot, add only hot liquid (80 °C).

In the event of an emergency, it is possible to use water as the coolant, but then proceed to drain the coolant circuit as quickly as possible.

- Open the engine hood.
- Check the correct level in the middle of gauge 1.
- If necessary, add coolant (➤ LUBRICANTS AND FUEL).
 - Slowly turn the cap of the radiator 2 up to the safety stop.
 - Allow the pressure and the steam to escape.
 - Press down and turn the cap so as to release it.
 - Add coolant via filler port 3 up to the middle of gauge 1.
 - Lubricate slightly the filler neck in order to facilitate the setting and the removal of the radiator cap.
- Visually check that there is no leakage or seepage.

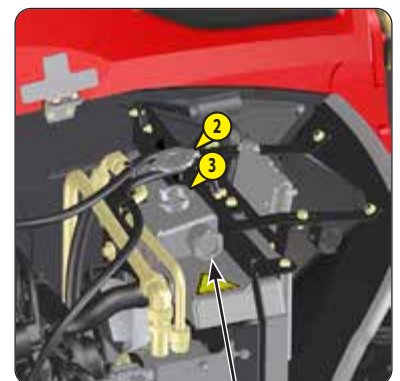

CHECK

Water separator

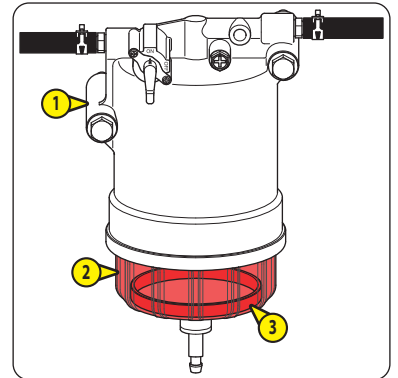

- Open the engine hood.
- Clean the outside of the water separator 1 with a clean cloth.
- Check the cleanliness of the fuel: there should be no impurities in the tank 2.
- Check that there is no water in the tank: the float 3 must be at the bottom of the tank.
- If impurities are present in the tank, bleed the water separator ($\leq 50\text{H}$ - WEEKLY MAINTENANCE OR EVERY 50 HOURS OF SERVICE).
- Visually check that there is no leakage or seepage.





CHECK

Longitudinal stability limiter and warning device

Place the machine on flat, level ground with the wheels straight.

- Press the button  to display the "PREFERENCES" menu.
- Press the button  to select from the menus and sub-menus.

HYDRAULICS > STABILITY TEST

- Press knob  to confirm.
- Follow the steps described on the information screen (OK = press button ).

⚠ IMPORTANT ⚠

If an error code is displayed, recalibrating the longitudinal stability limiter and warning device may resolve the problem (≤ 1 OCCASIONAL MAINTENANCE).

CLEAN

Cyclonic pre-filter (OPTION)

The cleaning interval is given as a guide, however the pre-filter must be emptied and cleaned as soon as impurities reach the MAX level on the tank.

⚠ IMPORTANT ⚠

When cleaning, take care not to let impurities into the dry air filter.

- Loosen nut 1 remove cover 2 and empty the tank.
- Clean the pre-filter unit with a clean dry cloth and reassemble the unit.

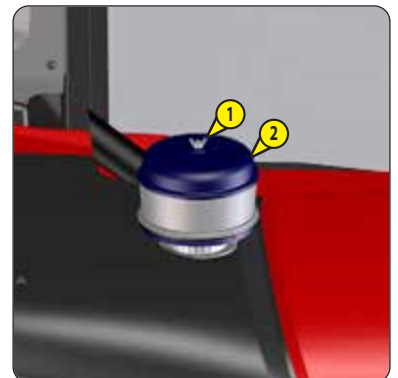

50H - WEEKLY MAINTENANCE OR EVERY 50 HOURS OF SERVICE

CHECK

Alternator belt tension *

⚠ IMPORTANT ⚠

If the belt is changed, check the tension again after the first 20 hours of service.

- Open the engine hood.
- Check the condition of the belt for signs of wear or cracking and replace it if necessary.
- Check the tension between the crankshaft and alternator pulleys.
- Apply pressure with the thumb (98 N); the clearance should be approximately 10 mm.
- Adjust if necessary.
 - Loosen screws 1 by two to three thread turns.
 - Swivel the alternator assembly so as to obtain the belt tension required.
 - Retighten the screws 1.

** Only for the first 50 hours of service, and then every 250 hours of service.*



CHECK

Air conditioning compressor belt tension (OPTION) *

⚠ IMPORTANT ⚠

If the belt is changed, check the tension again after the first 20 hours of service.

- Open the engine hood.
- Check the belt for signs of wear and cracks and change if necessary.
- Check the belt tension between the pulleys of the crankshaft and the compressor.
- Apply pressure with the thumb (98 N); the clearance should be approximately 10 mm.
- Adjust if necessary.
 - Loosen screws 1 by two to three thread turns.
 - Swivel the compressor assembly so as to obtain the belt tension required.
 - Retighten the screws 1.

** Only for the first 50 hours of service, and then every 250 hours of service.*

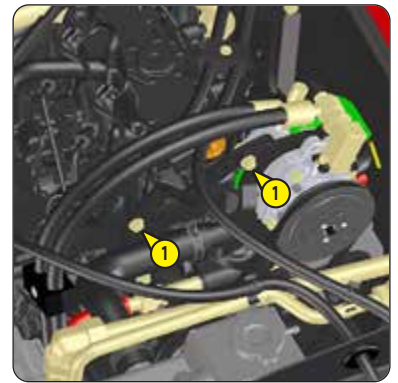

CHECK

Transfer box seal

Set the machine on level ground with the engine stopped.

- Carefully clean the breather 1 and surrounding area.
- Visually check for any traces of seepage or leakage from the various filler, level and drain plugs.
- If there is any leakage or seepage, check the level:
 - Remove the level plug 1, the oil should be flush with the edge of the hole.
 - If necessary, add oil (↖ LUBRICANTS AND FUEL) through the same hole.
 - Refit and tighten the level plug (tightening torque 80 N.m -28 N.m/+4 N.m).
- Carefully clean the breather 2 and surrounding area.

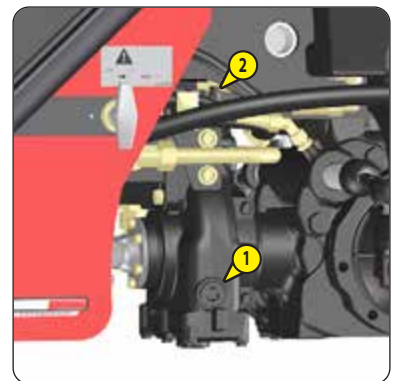

CHECK

Front axle differential seal

CHECK

Rear axle differential seal

Set the machine on level ground with the engine stopped.

- Visually check for any traces of seepage or leakage from the various filler, level and drain plugs.
- If there is any leakage or seepage, check the level.
 - Remove the level plug 1, the oil should be flush with the edge of the hole.
 - If necessary, add oil (↖ LUBRICANTS AND FUEL) through the same hole.
 - Refit and tighten the level plug (tightening torque 70 N.m -10 N.m/+3,5 N.m).



CHECK

Front wheel reducer seals

CHECK

Rear wheel reducer seals

Set the machine on level ground with the engine stopped.

- Visually check for any traces of seepage or leakage from the level plug.
- If there is any leakage or seepage, check the level.
 - Place level plug 1 in a horizontal position.
 - Remove the level plug; the oil should be flush with the edge of the opening.
 - If necessary, add oil (↖ LUBRICANTS AND FUEL) through the same hole.
 - Refit and tighten the level plug (tightening torque 70 N.m -10 N.m/+3,5 N.m).



CHECK

Tire pressure

CHECK

Wheel nut tightening

⚠ IMPORTANT ⚠

Check that the air hose is correctly connected to the tire valve before inflating and keep all persons at a distance during inflation. Inflate to the recommended tire pressures.

- Check the condition of the tires, to detect cuts, blisters, wear, etc.
- Check the wheel nut torque. Non-compliance with this instruction can lead to deterioration and breakage of the wheel lugs and distortion of the wheels.
- Check and restore tire pressure, if necessary (↖ 2 - DESCRIPTION: TIRES).

CHECK

Brake fluid level

Place the machine on level ground.

⚠ IMPORTANT ⚠

If the brake fluid level is abnormal, consult your dealer.

- Open the protective panel 1.
- Check tank 2. The correct level should be at the MAX. level on the tank.
- If necessary, add oil (↖ LUBRICANTS AND FUEL).
- Remove the cap 3.
- Add oil through filler port.
- Refit the filter and protective casing.
- Visually check that there is no leakage in the tank and pipes.

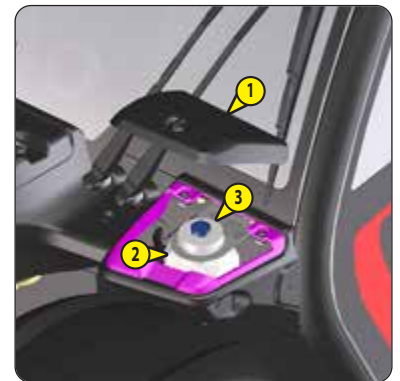

CHECK

Boom pad slide pathways

To preserve optimum operation, the pad slide pathways should be correctly lubricated:

⚠ IMPORTANT ⚠

MANDATORY GREASING OF THE BOOM AFTER:
Cleaning the boom, especially after using high pressure cleaner.
Machine not used for a long time.

- Fully extend the boom.
- Check the condition of the surface of the pad slide pathways, surface run in (steel whitened) without traces of corrosion.
- If necessary lubricate the pad slide pathways (↖ LUBRICANTS AND FUEL).
- Telescope the boom several times in order to spread the coat of grease evenly.
- Remove the surplus of grease.



⚠ IMPORTANT ⚠

If the machine is used in an abrasive environment (dust, sand, coal) use lubricating varnish (Part no. MANITOU: 483536). Consult your dealer.

CHECK

Hydraulic fluid level

Place the machine on level ground with the engine stopped, and the boom retracted and lowered as far as possible.

⚠ IMPORTANT ⚠

Use a very clean funnel and clean the top of the oil can before filling.

- Check dipstick 1, the correct level must be at the level of the red dot.
- If necessary, add oil (⇐ LUBRICANTS AND FUEL).
- Remove the cap 2.
- Add oil through filler port 3.
- Refit the cap.
- Visually check that there is no leakage or seepage.

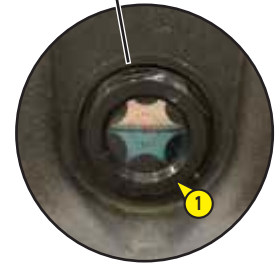

CHECK

Windshield washer liquid level (OPTION)

- Open the protective panel 1.
- Visually check the level in tank 2.
- If necessary, add windshield washer fluid (⇐ LUBRICANTS AND FUEL).
- Remove the cap 3.
- Add windshield washer liquid through filler port.
- Refit the filter and protective casing.

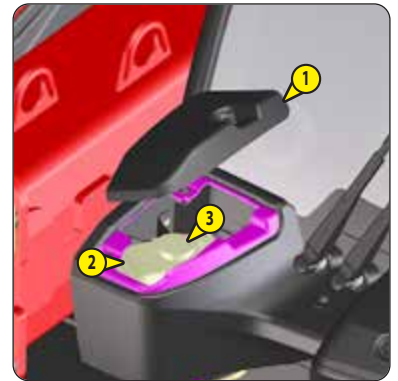

CLEAN

Radiator cores

⚠ IMPORTANT ⚠

In a polluting atmosphere, clean the radiator cores every day. Do not use a water jet or high pressure steam as this could damage the fins.

- Open the engine hood.
- Remove the panel 1.
- Clean the ventilation grilles on the engine hood and the discharge casing.
- Using a soft cloth, clean the radiator cores in order to remove as much dirt as possible.
- Clean the radiator using a compressed air jet aimed from the engine toward the radiator, in the opposite direction to the cooling air flow.
- Refit the panel 1.



CLEAN

Dry air filter cartridge

In case of use in a heavily dust-laden atmosphere, there are pre-filtration cartridges. The cartridge checking and cleaning interval must also be reduced.

⚠ IMPORTANT ⚠

Never use the machine without an air filter or with a damaged air filter.

Maintain a safety distance of 30 mm between the jet of air and the cartridge to avoid tearing or piercing the cartridge. The cartridge must not be blown through close to the air filter casing. Never clean the cartridge by tapping it on a hard surface. Protect your eyes during this operation.

Do not clean the dry air filter cartridge by washing it in liquid. Never clean the safety cartridge located inside the filter cartridge. Change it for a new one if it is clogged or damaged.

- For the dismantling and refitting of the cartridge (⚡ 1000H: REPLACE Air filter cartridge).
- Clean the filter cartridge using a compressed air jet (max. pressure 3 bars) directed from the top to the bottom and from the inside toward the outside at a minimum distance of 30 mm from the cartridge wall.
- Cleaning is completed when there is no more dust on the cartridge.
- Clean the cartridge seal surface with a damp, clean lint-free cloth and grease with a silicone lubricant (part no. MANITOU: 479292).
- Visually inspect the external condition of the air filter and its mounts. Also check the condition and attachment of the hoses.

CLEAN

Condenser core (OPTION)

⚠ IMPORTANT ⚠

In a polluting atmosphere, clean the radiator harness daily. Do not use a water jet or high-pressure steam as this could damage the condenser fins.

- Remove the protective grid 1 and clean it if necessary.
- Visually check whether the condenser is clean and clean it if necessary.
- Clean the condenser using a compressed air jet aimed in the same direction as the air flow.
- Clean with the fan running for best results.

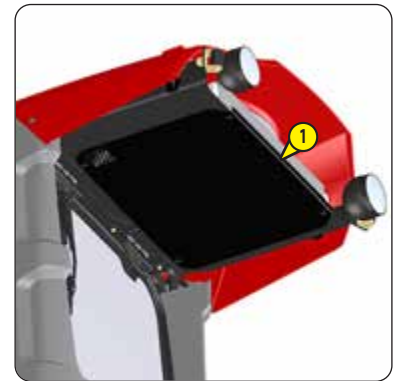

CLEAN

Fan

LUBRICATE

General lubrication

To be carried out weekly, if the machine has been operated for less than 50 hours during the week.

⚠ IMPORTANT ⚠

In the event of prolonged use in an extremely dusty or oxidizing atmosphere, reduce this interval to 10 hours of service or every day.

Clean, then lubricate the following points with grease (⚡ LUBRICANTS AND FUEL) and remove the surplus.

BOOM

- 1 - Lubricators of the boom pin (2 lubricators).
- 2 - Lubricator of the carriage pin (1 lubricator).
- 3 - Lubricators of the carriage connecting rod pins (3 lubricators).
- 4 - Lubricators of the attachment locking levers (2 lubricators).
- 5 - Lubricator of the tilting cylinder foot pin (1 lubricator).
- 6 - Lubricator of the tilting cylinder head pin (1 lubricator).
- 7 - Lubricator of the lifting cylinder foot pin (1 lubricator).
- 8 - Lubricator of the lifting cylinder head pin (1 lubricator).

REAR AXLE OSCILLATION

- 9 - Rear axle oscillation lubricator (1 lubricator).

CHASSIS

- 10 - Lubricator of the towing clevis (1 lubricator) (OPTION)

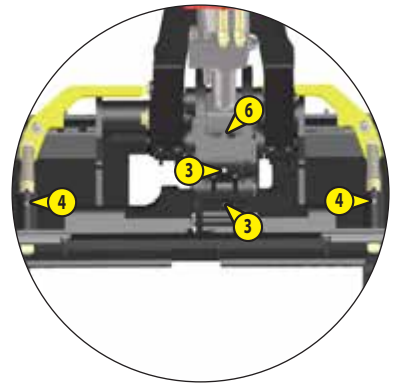
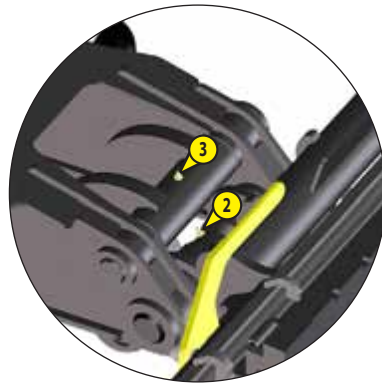

⚠ IMPORTANT ⚠

*Carefully clean the outside of the water separator and its holder to prevent dust from getting into the system.
Bleed the water separator more often if impurities or water are regularly detected during daily maintenance.*

- Open the engine hood.
- Turn the tap 1 to the OFF position "OFF".
- Place a receptacle under the bleed valve 2 and unscrew it by two thread turns.
- If the water does not flow, undo the bleed screw 3 by two to three turns.
- If the water still does not flow, turn the valve 1 to the ON position "ON".
- Do up the bleed valve 2 by hand (tightening torque 1,5 N.m \pm 0,5 N.m) when:
 - There are no impurities in the tank 4.
 - The float 5 is at the bottom of the tank.
- Do the bleed screw 3 back up if it has been loosened.
- Bleed the fuel supply circuit (↩ OCCASIONAL MAINTENANCE).

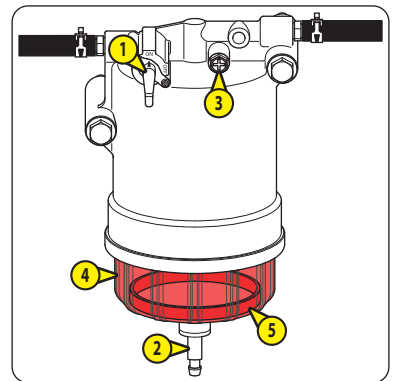
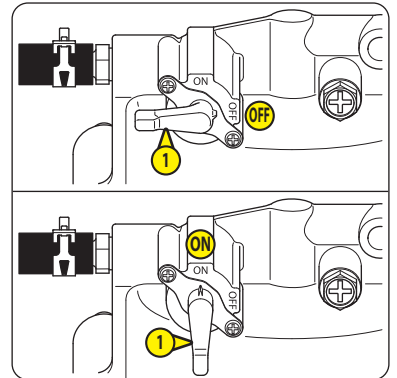

CHECK

Alternator belt tension

⚠ IMPORTANT ⚠

If the belt is changed, check the tension again after the first 20 hours of service.

Replace the belt if there is any doubt about its condition.

Belt adjustment or replacement operations must be performed by qualified personnel (see your dealer).

- Open the engine hood.
- Check the condition of the belt. Ensure there are no cracks or signs of wear:
 - If the condition is correct, check the belt tension.
 - If the condition is not correct, replace the belt.



CHECK THE BELT TENSION

- Check the belt tension between the crankshaft pulley and the alternator pulley:
 - Apply pressure with the thumb = 98 N. The clearance must be between 10 mm and 14 mm to be correct.
- Adjust if necessary:
 - Loosen the screws ①.
 - Adjust the belt tension by swiveling the alternator.
 - Tighten the screws ①.
 - Check the belt tension again.
- Close the engine hood.

REPLACE THE BELT

- Replace the belt:
 - Loosen the screws ①.
 - Remove the used belt by swiveling the alternator.
 - Replace it with a new belt.
- Adjust the belt tension between the crankshaft pulley and the alternator pulley:
 - Apply pressure with the thumb = 98 N. The clearance must be between 8 mm and 12 mm to be correct.
- Tighten the screws ①.
- Start the engine.
- Allow it to idle for 5 minutes.
- Switch off the engine.
- Check the belt tension between the crankshaft pulley and the alternator pulley:
 - Apply pressure with the thumb = 98 N. The clearance must be between 10 mm and 14 mm to be correct.
- Adjust if necessary:
 - Loosen the screws ①.
 - Adjust the belt tension by swiveling the alternator.
 - Tighten the screws ①.
 - Check the belt tension again.
- Close the engine hood.

CHECK

Air conditioning compressor belt tension (OPTION)

⚠ IMPORTANT ⚠

If the belt is changed, check the tension again after the first 20 hours of service.

Belt adjustment or replacement operations must be performed by qualified personnel (see your dealer).

- Open the engine hood.
- Check the belt for signs of wear and cracks and change if necessary.
- Check the belt tension between the pulleys of the crankshaft and the compressor.
- Apply pressure with the thumb (98 N); the clearance should be approximately 10 mm.
- Carry out adjustments if necessary:
 - Loosen screws 1 by two to three thread turns.
 - Swivel the compressor assembly so as to obtain the belt tension required.
 - Retighten the screws 1.

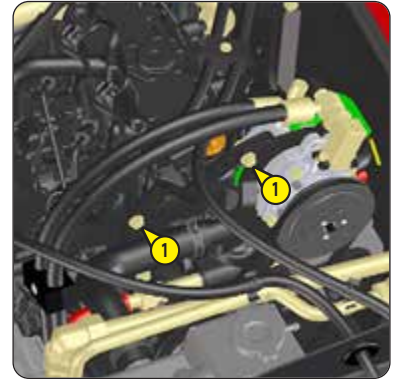

ALSO CARRY OUT THE PERIODIC MAINTENANCE FOR 250 HOURS OF SERVICE.

CHECK

Hydraulic oil

MANITOU offers a hydraulic fluid analysis kit which might make it possible to delay the recommended deadline in the periodic maintenance schedule (2,000 hours). In this case we recommend an analysis of the hydraulic oil every 500 hours or 1 year of service.

The oil analysis kit also makes it possible to confirm the oil quality so as to obtain a deadline of 2,000 hours for specific uses causing constraints on the hydraulic circuit: extreme environmental conditions, use of the attachments with a very high hydraulic flow rate (such as a sweeper, or a concrete mixer).

- Order an oil analysis kit from your dealer.
- Upon receiving the kit, take a sample of oil and follow the instructions shown on the kit.
- According to the results, keep the analysis report or replace the hydraulic fluid.

Oil analysis kit (part no MANITOU: 958162)



REPLACE

Engine oil

REPLACE

Engine oil filter

Set the machine on a horizontal surface, leave the engine idling for a few minutes and then switch it off.

⚠ IMPORTANT ⚠

Dispose of the used oil in an ecological manner.

DRAINING THE OIL

- Open the engine hood.
- Remove access panel 1.

NOTE: When removing cover plates and hatches, clean the surrounding area and remove any accumulations of flammable materials.

- Place a container under the drain hole and unscrew the drain plug 2.
- Remove the filler plugs 3 to ensure correct drainage.

REPLACEMENT OF THE FILTER

- Unscrew and discard the engine oil filter 4, together with its seal.
- Clean the filter bracket with a clean, lint-free cloth.
- Lightly grease the seal before fitting the new oil filter.
- Screw in the engine oil filter by hand until it touches the mounting surface.
- Tighten it by one turn using a filter wrench (tightening torque = 21,5 N.m ± 2 N.m).

FILLING WITH OIL

- Refit and tighten the drain plug 2 (tightening torque = 58,8 N.m ± 5 N.m).
- Fill up with oil (↖ LUBRICANTS AND FUEL) through one of the filler holes 3.
- Wait a few minutes to allow the oil to flow into the sump.
- Start the engine and let it run for a few minutes.
- Check for possible leaks from the drain plug and the oil filter.
- Stop the engine, wait a few minutes and check the correct level between the two marks on the dipstick 5.
- Top up the level, if necessary.
- Refit the access cover 1.

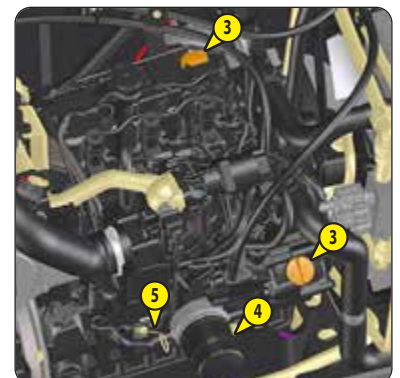

⚠ IMPORTANT ⚠

Carefully clean the outside of the water separator and around it, to prevent dust from getting into the system.

- Open the engine hood.
- Place a receptacle under the water separator 1.
- Turn the tap 2 to the OFF position "OFF".
- Unscrew the bleed valve 3.
- Loosen the bleed screw 4 by two or three turns.
- Do the bleed valve 3 back up by hand (tightening torque 1,5 N.m \pm 0,5 N.m) when the tank 5 is empty.
- Retighten the bleeder screw 4.
- Replace the water separator cartridge:
 - Unscrew the tank 5 and remove it. Take care, as the used water separator cartridge could fall out.
 - Remove the used water separator cartridge.
 - Clean the tank with clean fuel (\leftarrow LUBRICANTS AND FUEL).
 - Check its condition. Replace it if necessary.
 - Check the condition of the tank seal. Replace it if necessary.
 - Check the condition of the float 6. Replace it if necessary.
 - Put the new water separator cartridge in place.
 - Put the float back in the tank.
 - Retighten the tank by hand (tightening torque 30 N.m \pm 3 N.m).
- Check the condition of the fuel hoses and the hose clamps. Replace them if necessary.
- Replace the fuel filter.

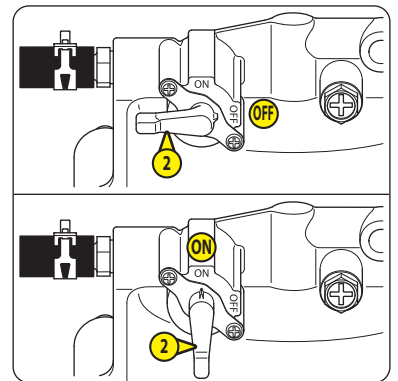
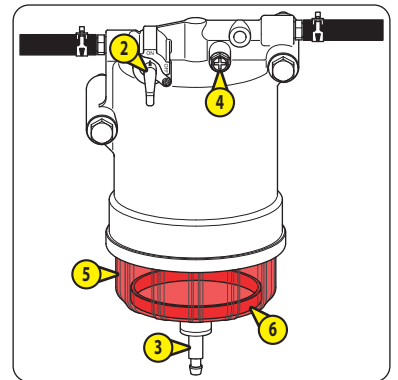

REPLACE

Fuel filter

⚠ IMPORTANT ⚠

Carefully clean the outside of the filter and around it, to prevent dust from getting into the system.

- Open the engine hood.
- Remove the protective casing 1.
- Place a container under the fuel filter 2.
- Replace the fuel filter:
 - Unscrew the used fuel filter.
 - Clean the inside of the filter head using a brush immersed in clean fuel (↩ LUBRICANTS AND FUEL).
 - Lubricate the seal of the new fuel filter with clean fuel (↩ LUBRICANTS AND FUEL).
 - Screw in the new fuel filter by hand until it makes contact with the mounting surface.
 - Tighten it by one turn using a filter wrench (tightening torque $22 \text{ N.m} \pm 2 \text{ N.m}$).
- Check the condition of the fuel hoses and the hose clamps. Replace them if necessary.
- Bleed the fuel supply circuit.
 - Turn the faucet 3 to the ON position "ON".
 - Switch on the machine ignition for 15 seconds to give the lift pump time to prime the fuel circuit.
 - Start the engine.
 - Allow it to idle for 5 minutes.
- Check for fuel leaks from the water separator and the fuel filter.
- Switch off the ignition with the ignition key.

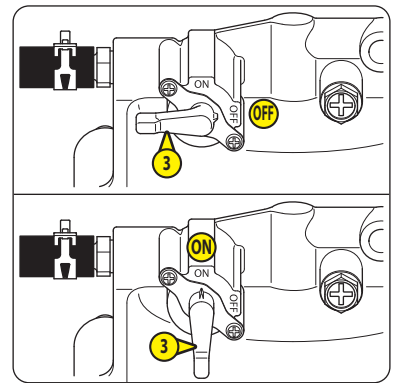

REPLACE

Hydraulic return oil filter cartridge

Stop the engine and release the pressure from the systems by operating the hydraulic controls.

⚠ IMPORTANT ⚠

Thoroughly clean the outside of the filter and its surroundings before any operation to prevent any risk of polluting the hydraulic system.

- Unscrew the filter cover 1.
- Remove the filter slowly and wait a few seconds for the oil to flow into the container.
- Keep the cover firmly closed and turn the cartridge clockwise a quarter turn to release the cartridge.
- Fit a new cartridge onto the cover.
- Refit the assembly in the tank, ensuring that the cartridge is correctly positioned, and refit the cover.

REPLACE

Cab fan filter

INTERNAL CAB VENTILATION FILTER

- Open the protective panel 1.
- Remove the cab ventilation filter and replace it with a new one.
- Refit the protective casing.



CHECK

Fork wear *

CHECK

Air intake line and air suction hose *

*** Consult your dealer.**

🔧 1000H - PERIODIC MAINTENANCE - EVERY 1,000 HOURS OF SERVICE OR 2 YEARS

ALSO CARRY OUT THE PERIODIC MAINTENANCE FOR 500 HOURS OF SERVICE.

CHECK

Seat belt

⚠️ IMPORTANT ⚠️

*Under no circumstances must the machine be used if the seat belt is defective (fixing, locking, cuts, tears, etc.).
Immediately repair or replace the seat belt.*

SEAT BELT WITH TWO ANCHORING POINTS

- Check the following points:
 - Fixing of the anchoring points on the seat.
 - Cleanness of the strap and the locking mechanism.
 - Triggering of the locking mechanism.
 - Condition of the strap (cuts, curled edges).

REELED SEAT BELT WITH TWO ANCHORING POINTS

- Check the points listed above together with the following points:
 - The correct winding of the belt.
 - Condition of the reel guards.
 - Roller locking mechanism when the strap is given a sharp tug.

NOTE: Replace the seat belt after an accident.

CLEAN

Fuel tank

REPLACE

Fuel tank breather

Set the machine on level ground with the engine stopped.

⚠️ IMPORTANT ⚠️

Do not smoke or approach with a flame during this operation.

Never attempt to carry out welding or any other operation by yourself, as this could cause an explosion or a fire.

- Inspect the parts of the fuel circuit and the tank liable to leak, both visually and by touch.
- In the event of a leak, contact your dealer.
- Place a container under drain plug 1 and unscrew the plug.
- Remove the filler plug 2 to ensure correct drainage.
- Rinse with ten litres of clean diesel through the filler port.
- Refit and tighten the drain plug 1 (tightening torque 10 N.m).
- Remove the wheel arch, unscrew the breather 3 and replace it with a new one (tightening torque 5 ± 2 N.m).
- Fill the fuel tank with clean diesel filtered through the filler port.
- Refit the filler plug.



REPLACE

Dry air filter cartridge

In case of use in a heavily dust-laden atmosphere, there are pre-filtration cartridges. Also, the checking and cleaning periodicity of the cartridge must be reduced (up to 250 hours in a very dusty atmosphere and with pre-filtration).

⚠ IMPORTANT ⚠

Change the cartridge in a clean location, with the engine stopped. Never operate the machine with a cartridge removed or damaged.

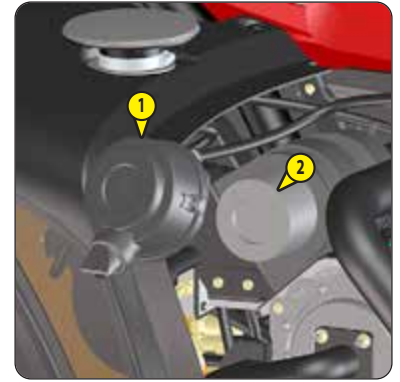

- Open the engine hood.
- Loosen the locks and remove cover 1.
- Gently remove the cartridge 2 to reduce dust falling as far as possible.
- Leave the safety cartridge in place.
- Carefully clean the following parts with a damp, clean lint-free cloth.
 - The inside of the filter and cover.
 - The inside of the filter inlet hose.
 - The gasket surfaces in the filter and in the cover.
- Check pipes and connections between the air filter and the engine and the connection and state of the clogging indicator on the filter.
- Before fitting, check the condition of the new cartridge.
- Insert the cartridge in the filter axis and push the cartridge pressing against the outer edge and not in the center.
- Reassemble the cover, guiding the valve downwards.

These operations are to be carried out as necessary or every 2 years at the beginning of winter. Place the machine on level ground with the engine stopped and cold.

⚠ IMPORTANT ⚠

The engine does not contain any anti-corrosion elements and must be filled throughout the year with a mixture containing 25% ethylene glycol-based antifreeze.

DRAINING THE LIQUID

- Open the engine hood.
- Remove access panel 1.
- Set a container under drain plug 2 on the radiator and under the cooling hose 3 of the engine oil filter.
- Unscrew the drain plug 2 and remove the hose 3 from the oil filter side.
- Remove filler plug 4 from the radiator and fully open the heating control to ensure correct drainage.
- Let the cooling circuit drain entirely while ensuring that the ports do not get clogged.
- Check the condition of the hoses as well as the fastening devices and change the hoses if necessary.
- Rinse the circuit with clean water and use a cleaning agent if necessary.

FILLING WITH COOLANT

- Refit and tighten the radiator drain plug 2.
- Refit the cooling hose 3.
- Slowly fill the system with coolant (⚠ LUBRICANTS AND FUEL) up to the middle of gauge 5 through filler port 6.
- Refit the filler plug 4.
- Run the engine at idle for a few minutes.
- Check for any possible leaks.
- Refit access panel 1.
- Check the level and top up if necessary.

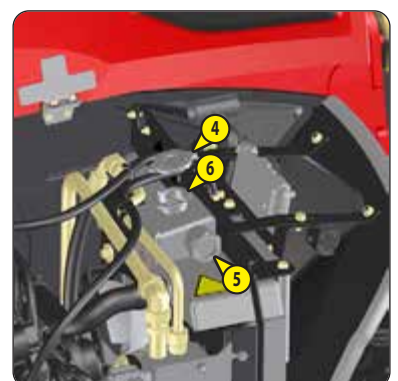

CHECK	Silentblocks **
CHECK	Valve lash **
CHECK	Injection pipes, fuel hoses and hose clamps **
CHECK	Hoses and hose clamps for the coolant radiator **
CHECK	Lubrication hoses **
CHECK	Brake system pressure *
CHECK	Boom pad wear *
CHECK	Condition of wiring harnesses and cables *
CHECK	Lights and signals *
CHECK	Horns *
CHECK	Condition of the rear view mirrors *
CHECK	Cab structure *
CHECK	Structure of the chassis *
CHECK	Attachment mounting system *
CHECK	Condition of attachments *
REPLACE	Brake fluid *

** Consult your dealer.*

*** Engine service, consult your dealer.*

④ 1500H - PERIODIC MAINTENANCE - EVERY 1500 HOURS OF SERVICE OR 3 YEARS

ALSO CARRY OUT THE PERIODIC MAINTENANCE FOR 500 HOURS OF SERVICE.

CHECK

Air circulation system in the engine crankcase **

** Engine service, consult your dealer.

REPLACE

Transfer box oil

Place the machine on level ground with the engine stopped and the transfer case oil still warm.

⚠ IMPORTANT ⚠

Dispose of the used oil in an ecological manner.

- Place a container under drain plug 1 and unscrew the plug.
- Remove level and filling plug 2 to ensure correct drainage.
- Refit and tighten the drain plug 1 (tightening torque 80 N.m -28 N.m/+4 N.m).
- Fill up with oil (↖ LUBRICANTS AND FUEL) through filler hole 2.
- The level is correct when the oil level is flush with the edge of the hole.
- Check for any possible leaks at the drain plug.
- Refit and tighten the level and filling plug 2 (tightening torque 80 N.m -28 N.m/+4 N.m).

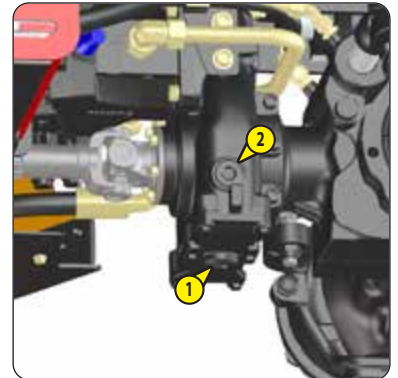

REPLACE

Front axle differential oil

REPLACE

Rear axle differential oil

Place the machine on level ground with the engine stopped and the differential oil still warm.

⚠ IMPORTANT ⚠

Dispose of the used oil in an ecological manner.

- Place a container under drain plug 1 and unscrew the plug.
- Remove level and filling plug 2 to ensure correct drainage.
- Refit and tighten the drain plug 1 (tightening torque 70 N.m -10 N.m/+3,5 N.m).
- Fill up with oil (↖ LUBRICANTS AND FUEL) through filler hole 2.
- The level is correct when the oil level is flush with the edge of the hole.
- Check for any possible leaks at the drain plug.
- Refit and tighten the level and filling plug 2 (tightening torque 70 N.m -10 N.m/+3,5 N.m).



REPLACE

Front wheel reducer oil

REPLACE

Rear wheel reducer oil

Place the machine on level ground with the engine stopped and the reducer oil still warm.

⚠ IMPORTANT ⚠

Dispose of the used oil in an ecological manner.

- Drain and change the oil of each wheel reduction gear.
- Place the drain plug 1 in position A, and unscrew it by two to three thread turns to release the pressure in the casing.
- Place drain plug 1 in position B.
- Place a container under the drain plug and remove the plug.
- Let the oil drain fully.
- Place the drain port in position C, i.e. in a level port.
- Fill up with oil (↖ LUBRICANTS AND FUEL) through level hole 1.
- The level is correct when the oil level is flush with the edge of the hole.
- Refit and tighten the drain plug (tightening torque 70 N.m -10 N.m/+3,5 N.m).

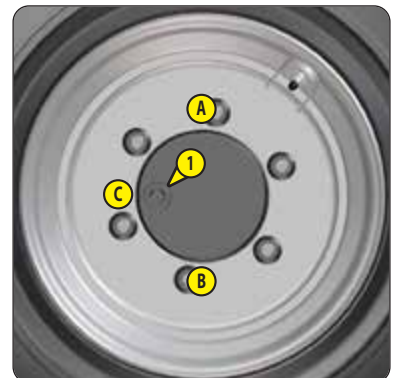

🔄 2000H - PERIODIC MAINTENANCE - EVERY 2,000 HOURS OF SERVICE OR EVERY 4 YEARS

ALSO PERFORM THE 500-HOUR AND 1,000-HOUR PERIODIC MAINTENANCE PROCEDURES.

CHECK

Wheel nut tightening torque

- Check the condition of the tires, to detect cuts, blisters, wear, etc.
- Check the tightening torque of the wheel nuts with a torque wrench.
 - Front wheels: 300 N.m ± 15 N.m
 - Rear wheels: 300 N.m ± 15 N.m

REPLACE

Dry air filter safety cartridge

⚠️ IMPORTANT ⚠️

The safety cartridge replacement frequency is given for information only. It must be changed every second time the dry air filter cartridge is changed.

- For the dismantling and refitting of the cartridge (⏪ 1000H: REPLACE Air filter cartridge).
- Carefully remove the dry air filter safety cartridge 1 to reduce dust fall as much as possible.
- Clean the gasket surface on the filter with a damp, clean lint-free cloth.
- Check the condition of the new safety cartridge before fitting.
- Insert the cartridge in the filter axis and push the cartridge pressing against the outer edge and not the center.



REPLACE

Hydraulic oil

CLEAN

Hydraulic oil tank suction strainer

Place the machine on level ground with the engine shut down and the boom retracted and lowered as far as possible.

⚠️ IMPORTANT ⚠️

Before any intervention, thoroughly clean the area surrounding the filter, the drain plugs and the suction cover on the hydraulic tank.

Dispose of the used oil in an ecological manner.

Use a clean container and funnel and clean the underside of the oil drum before filling.

DRAINING THE OIL

- Place a container under drain plug 1 and unscrew the plug.
- Remove the filler plug 2 to ensure correct drainage.

CLEANING THE SUCTION STRAINER

- Remove hose 3.
- Remove and clean the suction strainer 4 using a compressed air jet, check its condition and replace if necessary.
- Refit the strainer 4 and hose 3 making sure the seal is in the correct position.

FILLING WITH OIL

- Clean and refit the drain plug 1 (tightening torque 51 - 69 N.m).
- Fill up with oil (⏪ LUBRICANTS AND FUEL) through filler hole 5.
- Observe the oil level on dipstick 6, the oil level should be at the level of the red dot.
- Check for any possible leaks at the drain plugs.
- Refit the filler plug 2.

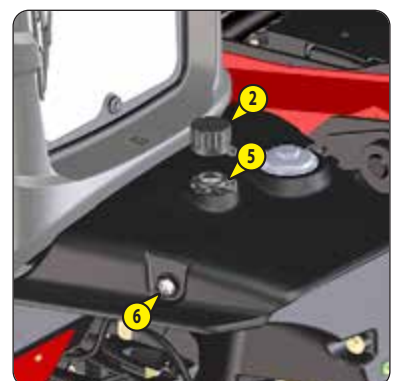
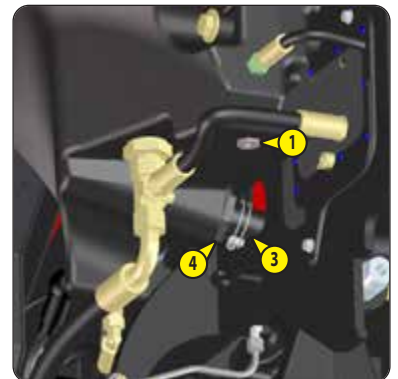

CHECK	Clearance of valve seats **
CHECK	Radiator *
CHECK	Transmission pressures *
CHECK	Steering *
CHECK	Steering swivel joints *
CHECK	Parking brake pad wear *
CHECK	Service brake pad wear *
CHECK	Brake disc wear *
CHECK	Condition of boom assembly *
CHECK	Bearings and bushings *
CHECK	Condition of hoses and flexible pipes *
CHECK	Condition of cylinders (leakage, rods) *
CHECK	Hydraulic circuit pressures *
CLEAN	Air conditioning (OPTION) *

CLEANING CONDENSER AND EVAPORATOR COILS

COLLECTING COOLANT TO REPLACE DRIER FILTER

REFILLING WITH COOLANT AND CHECKING THE THERMOSTATIC CONTROL AND PRESSURE SWITCHES

NOTE: When opening the evaporator unit, remember to replace the cover seal.



NEVER TRY TO REPAIR ANY FAULTS YOURSELF. WHEN REFILLING CIRCUITS, ALWAYS REFER TO A DEALER WHO HAS THE CORRECT SPARE PARTS AND THE TECHNICAL KNOWLEDGE AND TOOLS REQUIRED.

In any of the following circumstances, call a doctor.

If inhaled, take the victim to fresh air.

If there is contact with the skin, wash immediately with plenty of water .

If there is frostbite, apply a sterile dressing.

If there is contact with the eyes, rinse with clear water for 15 minutes.

IMPORTANT INFORMATION REGARDING THE COOLANT USED

- This product contains fluorinated greenhouse gases covered by the Kyoto Protocol.
- Coolant type: R134A; it is colorless and odorless and heavier than air. Its GWP (Global Warming Potential) is 1430.
- Do not allow the gases to escape into the atmosphere. Do not open the system under any circumstances, as this could cause refrigerant to escape.
- The compressor has a fluid level gage; never unscrew this gage because it would depressurize the system. The fluid level should only be checked when draining the system.

** Consult your dealer.*

*** Engine service, consult your dealer.*

🔁 3000H - PERIODIC MAINTENANCE - EVERY 3,000 HOURS OF SERVICE OR EVERY 6 YEARS

ALSO PERFORM THE 500-HOUR AND 1,000-HOUR PERIODIC MAINTENANCE PROCEDURES.

CHECK *Engine ECU (ECU) and associated sensors and actuators ***

CHECK *Diesel oxidation catalyst (DOC) of the diesel particulate filter (DPF) ***

CHECK *Intake valve ***

CHECK *Exhaust valve ***

CHECK AND CLEAN *Exhaust gas recirculation system valve (EGR) ***

CHECK AND CLEAN *Injectors ***





CLEAN *Exhaust gas recirculation system cooler (EGR) ***

**** Engine service, consult your dealer.**

⚠ IMPORTANT ⚠

Exhaust regeneration is an automated procedure activated by the operator when the following indicator lamps are displayed:



- Park the machine in a safe and adequately ventilated place.
- Check the following points:
 - forward/reverse selector in neutral,
 - parking brake applied,
 - boom angle less than 5°,
 - accelerator pedal released,
 - hand throttle not used (OPTION),
- Check that the fuel level is sufficient.
- Start the machine and run the engine for a few minutes to bring it up to its operating temperature.
- Press and hold the  button for at least two seconds to start the exhaust regeneration procedure.
- Lighting of the indicator lamp  plus a beep confirms the start of the "stationary machine" exhaust regeneration procedure.
- The "wait" display will flash throughout the "stationary machine" exhaust regeneration.
- Otherwise, "notice" will be displayed for 3 seconds indicating a fault in the procedure. In this event check the positioning of the machine and contact your dealer if necessary.
- At the end of the procedure, indicator lamps  +  go out.
- During the procedure, the engine speed increases to approx. 1,800 rpm, and the indicator lamp  comes on when the exhaust particle filter gases reach a high temperature.

⚠ IMPORTANT ⚠

The exhaust regeneration procedure must only be stopped if absolutely necessary.

The procedure stops automatically if the operator:

- activates the hydraulic control joystick,
- engages forward or reverse gear,
- switches off the engine,
- or presses the  button.

- The time taken for exhaust regeneration varies (between 15 and 30 minutes) according to several criteria, such as:
 - the level of clogging of the filter,
 - the ambient temperature,
 - the fuel quality and type of engine oil,
 - the number of exhaust particle filter automatic regeneration requests previously canceled.
- The engine will return to its initial idling speed to indicate that the procedure has finished.

⚠ IMPORTANT ⚠

Once the exhaust regeneration procedure is completed, leave the engine idling for a few minutes to lower the temperature before switching off the ignition.

REPLACE

Wheels

For this operation, we advise you to use the hydraulic jack (Part No. MANITOU: 505507) and the safety support prop (Part No. MANITOU: 554772).

⚠ IMPORTANT ⚠

In the event of a wheel being changed on the public highway, secure the machine vicinity:

- If possible, stop the machine on firm, level ground.
- Stop the machine (⚠ 1 - SAFETY INSTRUCTIONS: DRIVING INSTRUCTIONS UNLADEN AND LADEN).
- Switch on the hazard warning lights.
- Immobilize the machine in both directions on the axle opposite to the wheel to be changed.
- Unlock the nuts of the wheel to be changed.
- Place the jack under the flared axle tube, as near as possible to the wheel, and adjust the jack.
- Raise the wheel until it is clear of the ground and place the safety support under the axle.
- Completely unscrew the wheel nuts and remove them.
- Free the wheel using back and forth movements and roll it to the side.
- Slip the new wheel on the wheel hub.
- Hand-tighten the nuts, grease them if necessary.
- Remove the safety support prop and lower the machine using the jack.
- Tighten the wheel nuts to the prescribed torque value (⚠ 2000H - PERIODIC MAINTENANCE - EVERY 2000 HOURS OF SERVICE OR EVERY 4 YEARS) using a torque wrenchh.



⚠ IMPORTANT ⚠

Operate the battery cut-off for a minimum of 30 seconds after having switched off the ignition with the ignition key.
Handling and servicing a battery can be dangerous. Take the following precautions:

- Wear protective goggles.
- Keep the battery horizontal.
- Never smoke or work near a naked flame.
- Work in a well-ventilated area.

- In the event of electrolyte being spilled onto the skin or splashed in the eyes, rinse thoroughly with cold water for 15 minutes and call a doctor.

- Remove cover plate 1.
- Loosen the screw 2.
- Open the cab door.
- Loosen the screw 3 to lower the battery holder 4 by 2 to 3 centimeters.
- Release the top of the bracket 5 from its support 6.
- Hold on to the bracket and pivot the battery assembly downwards.

⚠ IMPORTANT ⚠

When removing the battery, make sure that the battery terminals do not come into contact with the battery cut-off terminals.

- Disconnect the battery, starting with the negative terminal, and remove the battery.
- Install a new battery of the same capacity.
- Lift the battery assembly and reposition the top of the bracket 5 in its support 6.
- Retighten screw 3 to put the battery assembly in the up position and retighten screw 2 to lock in place.
- Refit the cover plate 1.

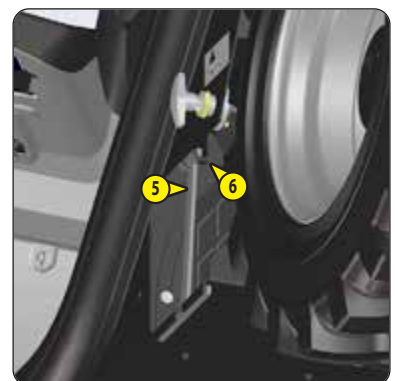
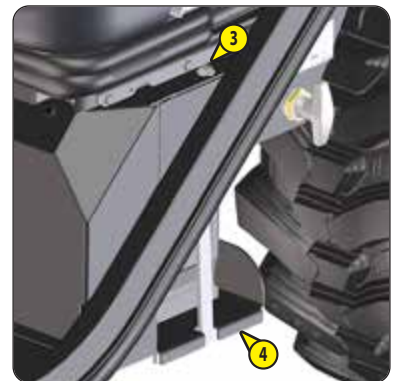

⚠ IMPORTANT ⚠

Always bleed the fuel supply circuit when:

- The fuel tank has been drained and then filled.
- There has been a fuel breakdown and then the fuel tank has been filled.
- A component of the fuel supply circuit has been cleaned or replaced.

If the engine runs irregularly or stops after bleeding the fuel supply circuit, check the condition of the entire fuel supply circuit.

- Open the engine hood.
- Turn the faucet 1 to the ON position "ON".
- Switch on the machine ignition for 15 seconds to give the lift pump time to prime the fuel circuit.
- Start the engine.
- Allow it to idle for 5 minutes.
- Check for fuel leaks.
- Switch off the ignition with the ignition key.

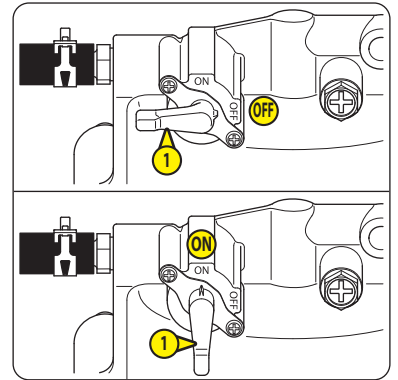

RESET

Longitudinal stability limiter and warning device

Depending on how the machine is used, the device may need to be periodically reset.



This operation can be easily performed by means of the following procedure.

- Provide a fork carrier or a bucket and a load corresponding to at least half the machine's rated capacity.
- Preferably perform the reset when the machine is still cold (before it is used) or ensure that the temperature of the rear axle is not more than 50 °C.



⚠ IMPORTANT ⚠

Carefully follow the boom positioning instructions.

When the reset is completed, check the operation of the longitudinal stability limiter and warning device (⚡ 10H - DAILY MAINTENANCE OR EVERY 10 HOURS OF SERVICE). If in doubt, consult your dealer.

- Place the machine on flat, level ground with the wheels straight.
- Press the button  to display the "PREFERENCES" menu.
- Press the button  to select from the menus and sub-menus.



- Press knob  to confirm.
- Follow the steps described on the information screen (OK = press button ).

CHECK

Disabling "AGGRAVATING" hydraulic movement cut-off

This operation can be easily performed by means of the following procedure.

⚠ IMPORTANT ⚠



In case of incorrect setting, consult your dealer.

LIFT TRUCK ON LEVEL GROUND

- Place the lift truck on flat and level ground with the wheels straight.
- Lower down the boom into transport position.
- Check lift truck horizontality on level indicators.



BOOM ANGLE

- Slowly lift the boom, stop hydraulic movement as soon as light  goes out, and check the lift angle ($< 10^{\circ} - 2^{\circ}$) on the boom.
- Slowly lower down the boom and stop hydraulic movement as soon as light  goes on.

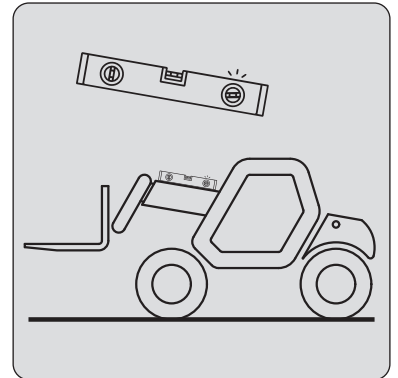

BOOM EXTENSION

- Slowly extend the boom, stop hydraulic movement as soon as light  goes out and check extension (1000 mm -200 mm).

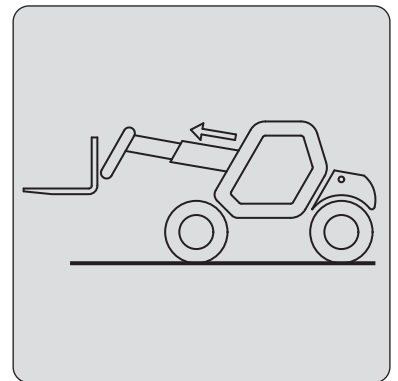

TOW/WINCH

Machine

⚠ IMPORTANT ⚠

If the machine is not on level ground, chock it so that it does not descend the slope.

The machine must be towed very slowly (less than 5 km/h) and for as short a distance as possible (less than 100 m).

To tow the machine, it is important to remove the transmission universal joint between the front and rear axle, lift the rear axle and release the parking brake on the front axle.

- Switch on the machine's ignition.
- Set the forward/reverse selector to neutral.
- Deactivate the parking brake.

REMOVE THE TRANSMISSION UNIVERSAL JOINT

- Hold on to the universal joint and loosen the screws 1 of the universal joint couplings at the level of the front axle 2 and rear axle 3.
- Remove the universal joint.

RELEASING THE PARKING BRAKE

- Press button 4 several times until pressing becomes difficult.
- This enables the brake disc to be released.

RAISE THE REAR OF THE MACHINE

- Raise the rear of the machine several centimeters using the slinging points 5

TOWING

- Switch on the hazard warning lights.

After towing:

- Refit the universal joint, add a drop of threadlock (Part No. MANITOU: 187526) to the screws 1 and tighten them (tightening torque 60 N.m ± 6 N.m).
- Press button 6 to retighten the brake disc.

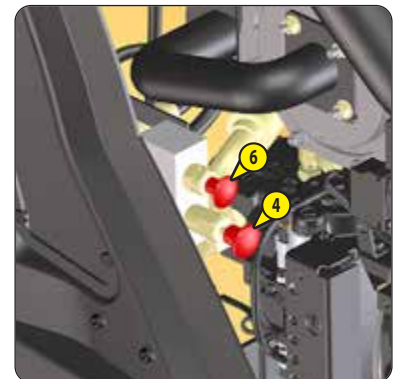
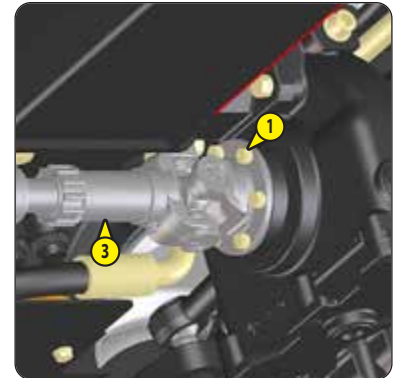
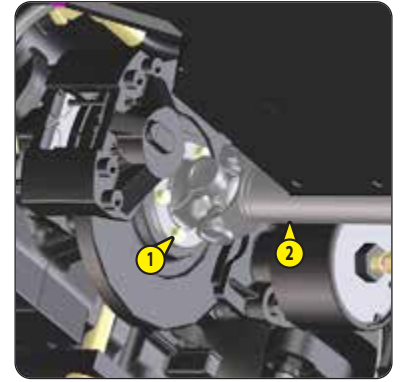

SLING

Machine

- Take into account the position of the machine's center of gravity for lifting.
- Place the hooks in the fastening points 1 provided.

A = 1110mm B = 1020mm ULM 412 H 36Y ST5 S1
 A = 1168mm B = 962mm ULM 415 H 36Y ST5 S1

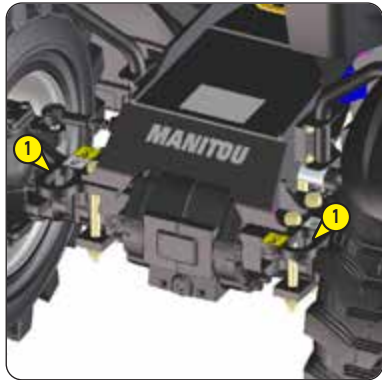
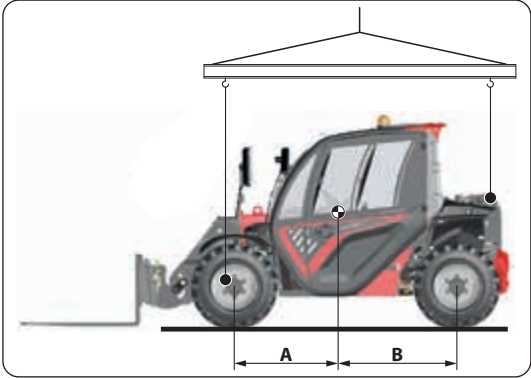

TRANSPORT

Machine on a truck deck

⚠ IMPORTANT ⚠

Check that the safety instructions associated with the flatbed have been correctly applied before loading the machine and ensure that the driver of the vehicle has been informed of the dimensional specifications and weight of the machine ($\leq 2 - DESCRIPTION: SPECIFICATIONS$).
 Ensure that the truck bed is of sufficient size and load capacity for transporting the machine.
 Check also the allowable ground contact pressure of the truck bed relative to the machine.

⚠ IMPORTANT ⚠

For machines equipped with a turbo-charged engine, block off the exhaust outlet to avoid rotation of the turbo shaft without lubrication when transporting the vehicle.



LOADING THE MACHINE

- Block the wheels of the platform.
- Fasten the loading ramps to the truck bed so as to obtain the shallowest possible angle for the machine to be loaded.
- Load the machine parallel to the truck bed.
- Stop the machine ($\leq 1 - OPERATING AND SAFETY INSTRUCTIONS: DRIVING INSTRUCTIONS UNLADEN AND LADEN$).

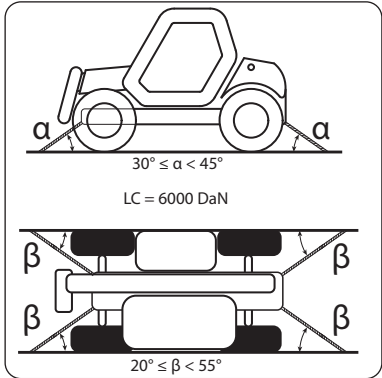

SECURING THE MACHINE

- Fix the chocks to the flatbed at the front and at the back of each tire.
- Also fix the chocks to the flatbed on the inside of each tire.
- Secure the machine to the flatbed with straps, in the anchoring points 1 provided.
- In order to ensure the machine is securely lashed to the flatbed, observe the lashing angles (α) and (β) and the resistance (LC) of the straps.
- Tighten the straps.

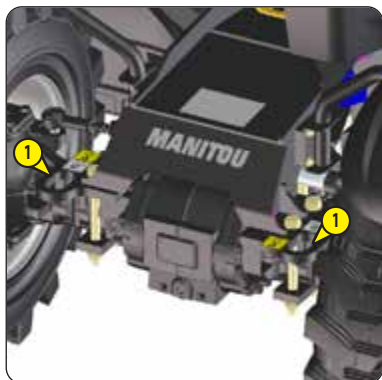

⚠ IMPORTANT ⚠

Check that the safety instructions associated with the flatbed have been correctly applied before loading the machine and ensure that the driver of the vehicle has been informed of the dimensional specifications and weight of the machine (↖ 2 - DESCRIPTION: SPECIFICATIONS).

Ensure that the truck bed is of sufficient size and load capacity for transporting the machine. Check also the allowable ground contact pressure of the truck bed relative to the machine.

⚠ IMPORTANT ⚠

For machines equipped with a turbo-charged engine, block off the exhaust outlet to avoid rotation of the turbo shaft without lubrication when transporting the vehicle.

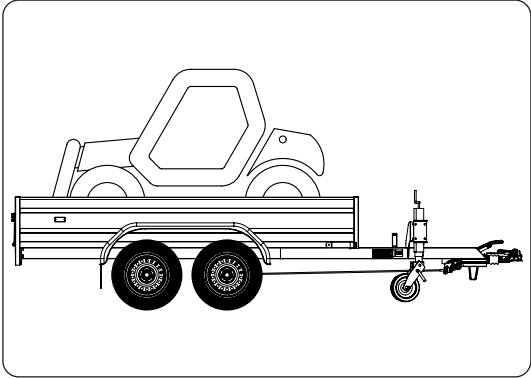

LOADING THE MACHINE

- Put the trailer in place on the traction vehicle to ensure that the trailer is secure.
- Put the loading ramps in place on the trailer.
- Load the machine in reverse gear parallel to the truck bed.
- Stop the machine (↖ 1 - OPERATING AND SAFETY INSTRUCTIONS: DRIVING INSTRUCTIONS UNLADEN AND LADEN).

SECURING THE MACHINE

- Secure the machine to the trailer with straps, in the anchoring points 1 provided.
- In order to ensure the machine is securely lashed to the flatbed, observe the lashing angles (α) and (β) and the resistance (LC) of the straps.
- Tighten the straps.

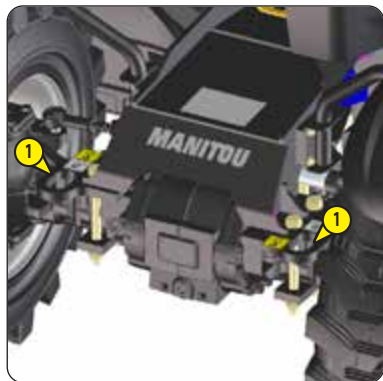
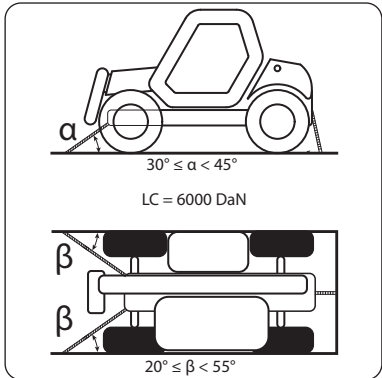

4 - ATTACHMENTS

4 - ATTACHMENTS

<u>INTRODUCTION</u>	<u>4-3</u>
<u>ENGAGING ATTACHMENTS ON THE CARRIAGE "4 POINTS"</u>	<u>4-4</u>
<u>ENGAGING ATTACHMENTS ON THE CARRIAGE "TSS" (OPTION)</u>	<u>4-5</u>
<u>TECHNICAL SPECIFICATIONS OF ATTACHMENTS</u>	<u>4-6</u>
<u>ATTACHMENT GUARDS</u>	<u>4-12</u>

INTRODUCTION

- Your machine must be used with interchangeable equipment. These items are called: ATTACHMENTS.
- A wide range of attachments is available, guaranteed by MANITOU and designed to fit your machine perfectly.

⚠ IMPORTANT ⚠

Only attachments approved by MANITOU can be used on these machines.

The manufacturer cannot be held responsible for any modifications or adaptations to attachments without its knowledge.

- The attachments are delivered with a load chart concerning your machine. The operator's manual and the load chart should be kept in the places provided in the machine. For standard attachments, their use is governed by the instructions contained on this notice.

⚠ IMPORTANT ⚠

Maximum loads are defined by the capacity of the machine, taking account of the attachment's weight and center of gravity.

Should the attachment have a lower capacity than the machine, never exceed this limit.

- Some particular uses require the adaptation of the attachment which is not provided in the price-listed options. Solutions exist, consult your dealer.

⚠ IMPORTANT ⚠

Depending on their size, certain attachments may, when the boom is lowered and retracted, come into contact with the front tires and cause damage to them if excavation is activated in the direction of the discharge.

TO PREVENT THIS RISK, EXTEND THE TELESCOPE TO A SUFFICIENT EXTENT FOR THE PARTICULAR MACHINE AND ATTACHMENT SO THAT THIS CONTACT IS NOT POSSIBLE.

SUSPENDED LOAD

⚠ IMPORTANT ⚠

Suspended loads MUST be handled with a machine designed for that purpose (← 1 - OPERATING AND SAFETY INSTRUCTIONS: INSTRUCTIONS FOR HANDLING LOADS: H - LIFTING UP AND SETTING DOWN A SUSPENDED LOAD).

ENGAGING ATTACHMENTS ON THE CARRIAGE "4 POINTS"

1 - FITTING AN ATTACHMENT WITHOUT HYDRAULICS

FITTING AN ATTACHMENT

- Ensure that the attachment is in a position facilitating the locking to the carriage. If it is not correctly oriented, take the necessary precautions in order to move it safely.
- Check that the locking pins 1 are in position on the carriage (Fig. A).
- Remove the pins 2 and set them aside with the locking pins (Fig. A).
- Place the lift truck with the boom lowered in front of and parallel to the attachment, and tilt the carriage forward.
- Bring the carriage under the attachment couplers 3, slightly raise the boom and tilt the carriage backward in order to position the attachment (Fig. B).
- Lift the attachment off the ground to facilitate locking.

MANUAL LOCKING

- Lock the attachment on both sides with the locking pins 1 (Fig. B). Do not forget to fit the pins.

MANUAL UNLOCKING

- Proceed in the reverse order to MANUAL LOCKING, taking care to refit the locking pins on the carriage (Fig. A).

REMOVING THE ATTACHMENT

- Proceed in the reverse order to FITTING AN ATTACHMENT, taking care to store the attachment flat on the ground and in the closed position.

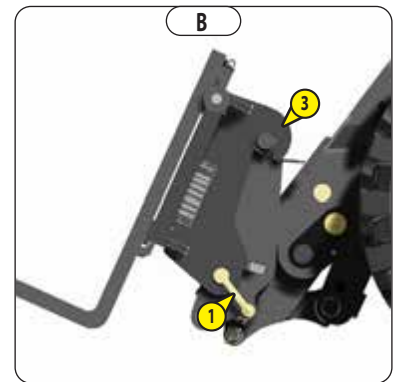
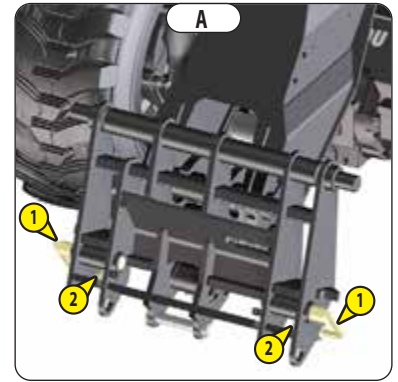

ENGAGING ATTACHMENTS ON THE CARRIAGE "TSS" (OPTION)

1 - FITTING AN ATTACHMENT WITHOUT HYDRAULICS

FITTING AN ATTACHMENT

- Ensure that the attachment is in a position facilitating the locking to the carriage. If it is not correctly oriented, take the necessary precautions in order to move it safely.
- Place the machine with the boom lowered, facing the attachment.
- Lift the levers 1 (fig. A).
- Tilt the carriage forwards (fig. A).
- Move the coupling points 2 of the carriage under the coupling points 3 on the attachment (fig. A).
- Lift the boom slightly and tilt the carriage backwards to position the attachment (Fig. B).
- Lift the attachment off the ground to facilitate locking.

MANUAL LOCKING

- Lower the levers 1 to lock the attachment (fig. B).

MANUAL UNLOCKING

- Proceed in the reverse order to MANUAL LOCKING .

REMOVING THE ATTACHMENT

- Proceed in the reverse order to FITTING AN ATTACHMENT, taking care to store the attachment flat on the ground and in the closed position.

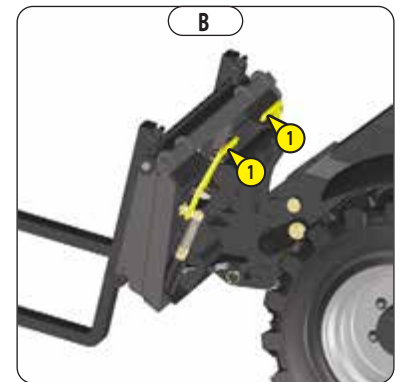
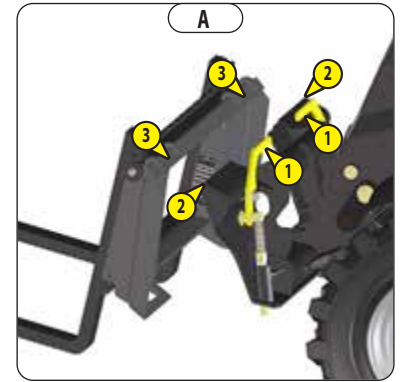

TECHNICAL SPECIFICATIONS OF ATTACHMENTS

SWEEPER

	"TSS"	"EURO"	"4 POINTS"
REFERENCE	SCB 1525 SK 52715996	SCB 1525 EU 52741070	SCB 1525 4P 52741071
Width	1525 mm	1525 mm	1525 mm
Weight	kg	kg	kg



BUCKET WITH GRAB

	"TSS"	"EURO"	"4 POINTS"
REFERENCE	BG 1500/600 WE SK 52736705	BG 1500/600 WE EU 52742063	BG 1500/600 WE 4P 52742062
Rated capacity	560 ℓ	560 ℓ	560 ℓ
Width	1500 mm	1500 mm	1500 mm
Teeth	6	6	6
Weight	350 kg	343 kg	346 kg



LIGHT MATERIAL BUCKET

	"TSS"	"EURO"	"4 POINTS"
REFERENCE	BLM 1500/770 SK 52706270	BLM 1500/770 EU 52723641	BLM 1500/770 4P 52723640
Rated capacity	763 ℓ	763 ℓ	763 ℓ
Width	1500 mm	1500 mm	1500 mm
Weight	212 kg	206 kg	209 kg



GENERAL PURPOSE BUCKET

	"TSS"	"EURO"	"4 POINTS"
REFERENCE	BGP 1500/400 ESSENTIAL SK 52702290	BGP 1500/400 ESSENTIAL EU 52723639	BGP 1500/400 ESSENTIAL 4P 52723638
Rated capacity	311 ℓ	311 ℓ	311 ℓ
Width	1500 mm	1500 mm	1500 mm
Weight	165 kg	157 kg	161 kg



MULTIPURPOSE BUCKET DISPLAY

	"TSS"	"EURO"	"4 POINTS"
REFERENCE	CB4X1 1500/340 SK 52707200	CB4X1 1500/340 EU 52742065	CB4X1 1500/340 4P 52742064
Rated capacity	336 ℓ	336 ℓ	336 ℓ
Width	1500 mm	1500 mm	1500 mm
Weight	345 kg	338 kg	341 kg



BALE FORK

	"TSS" FB 950/700 AT N51502684	"EURO" FB 950/700 EU N51502686	"4 POINTS" FB 950/700 4P N51502685
REFERENCE			
Rated capacity	700 kg	700 kg	700 kg
Width	1150 mm	1080 mm	1040 mm
Tines	2	2	2
Weight	76 kg	52 kg	48 kg

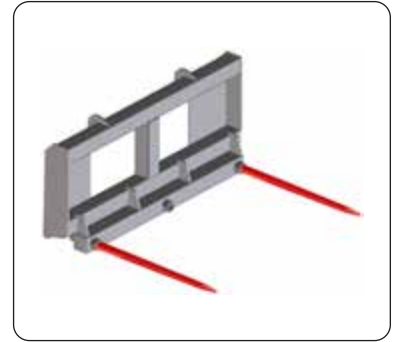

BALE FORK

	"TSS" FB 950/700 LB AT N51502687	"EURO" FB 950/700 LB EU N51502689	"4 POINTS" FB 950/700 LB 4P N51502688
REFERENCE			
Rated capacity	700 kg	700 kg	700 kg
Width	1150 mm	1127 mm	1127 mm
Tines	2	2	2
Weight	100 kg	72 kg	72 kg



MANURE FORK WITH GRAB

	"TSS" FFGR 1500/600 SK 52737500	"EURO" FFGR 1500/600 EU 52742069	"4 POINTS" FFGR 1500/600 4P 52742068
REFERENCE			
Rated capacity	600 ℓ	600 ℓ	600 ℓ
Width	1500 mm	1500 mm	1500 mm
Finger	7	7	7
Teeth	7	7	7
Weight	325 kg	340 kg	340 kg



SNOW BLADE

	"TSS" BLS 1650/900 SK N51502221	"EURO" BLS 1650/900 EU 52741072	"4 POINTS" BLS 1650/900 4P 52741074
REFERENCE			
Width	1650 mm	1650 mm	1650 mm
Weight	250 kg	250 kg	250 kg



WRAPPED BALE CLAMP

	"TSS" CLBW 800 AT N51502013	"EURO" CLBW 800 EU N51502430	"4 POINTS" CLBW 800 4P N51502429
REFERENCE			
Rated capacity	800 kg	800 kg	800 kg
Width	1587 mm	1587 mm	1587 mm
Weight	221 kg	203 kg	209 kg



ROUND BALE CLAMP

	"TSS" CLBR 2X2/800 AT N51502631	"EURO" CLBR 2X2/800 EU N51502633	"4 POINTS" CLBR 2X2/800 4P N51502632
REFERENCE			
Rated capacity	800 kg	800 kg	800 kg
Width	1212 mm	1136 mm	1090 mm
Weight	176 kg	170 kg	150 kg



POT CLAMP

	"TSS" CLP 1000/800 SK 939690	"EURO" CLP 1000/800 EU 52742067	"4 POINTS" CLP 1000/800 4P 52742066
REFERENCE			
Rated capacity	800 kg	800 kg	800 kg
Width	1149 mm	1024 mm	686 mm
Weight	109 kg	123 kg	120 kg



CRANE

	"TSS" JH 2500 SK 52579090	"EURO" JH 2500 EU 52742071	"4 POINTS" JH 2500 4P 52742070
REFERENCE			
Rated capacity	2500 kg	2500 kg	2500 kg
Width	1138 mm	1024 mm	696 mm
Weight	110 kg	90 kg	85 kg



BOOM CRANE WITH BIG BAG

	"TSS" HBB 1500/2400 SK 52578030	"EURO" HBB 1500/2400 EU 52742059	"4 POINTS" HBB 1500/2400 4P 52742058
REFERENCE			
Rated capacity	2400 kg	2400 kg	2400 kg
Width	1356 mm	1356 mm	1356 mm
Weight	186 kg	166 kg	166 kg



TILTING FORKS CARRIAGE

	"TSS" CAT 1020/1500 SK 52706271	"EURO" CAT 1020/1500 EU 52723637	"4 POINTS" CAT 1020/1500 4P 52723636
REFERENCE			
Rated capacity	1500 kg	1500 kg	1500 kg
Width	1156 mm	1052 mm	1052 mm
Weight	147 kg	150 kg	137 kg



FLOATING FORK CARRIAGE

	"TSS"	"EURO"	"4 POINTS"
REFERENCE	CAF 1000/1500 SK 52693600	CAF 1000/1500 EU 52723635	CAF 1000/1500 4P 52723634
Rated capacity	1500 kg	1500 kg	1500 kg
Width	1156 mm	1050 mm	1002 mm
Weight	175 kg	165 kg	153 kg



STRAIGHT SNOW BLADE

	"TSS"	"EURO"	"4 POINTS"
REFERENCE	BLS 1650/900 SK N51502221	BLS 1650/900 EU 52741072	BLS 1650/900 4P 52741074
Width	1650 mm	1650 mm	1650 mm
Depth	900 mm	900 mm	900 mm
Height	700 mm	700 mm	700 mm
Weight	250 kg	250 kg	250 kg



PRUNER

	"TSS"	"EURO"	"4 POINTS"
REFERENCE	PRC 1500/ 180 R SK 52728899	PRC 1500/ 180 R EU 52741064	PRC 1500/ 180 R 4P 52741065
Rated capacity			
Width			
Weight			



HEDGE TRIMMER

	"TSS"	"EURO"	"4 POINTS"
REFERENCE	PRSH 1500 SK 52728898	PRSH 1500 EU 52741067	PRSH 1500 4P 52741069
Rated capacity			
Width			
Weight			

SNOW BLOWER

	"TSS"	"EURO"	"4 POINTS"
REFERENCE	SB 1600 SK 52728004	SB 1600 EU 52741327	SB 1600 4P 52741325
Rated capacity			
Width			
Weight			

SLASH CUTTER

	"TSS"	"EURO"	"4 POINTS"
REFERENCE	MV 1500 SK 52728002	MV 1500 EU 52741075	MV 1500 4P 52741076
Rated capacity			
Width			
Weight			

AUGER

	"TSS"	"EURO"	"4 POINTS"
REFERENCE	A 110 H SK 52728005	/	A 90 H 4P 52741078
Length	1000 mm	/	1000 mm
Diameter	250 mm	/	250 mm



ATTACHMENT GUARDS

FORK GUARD

REFERENCE 227801

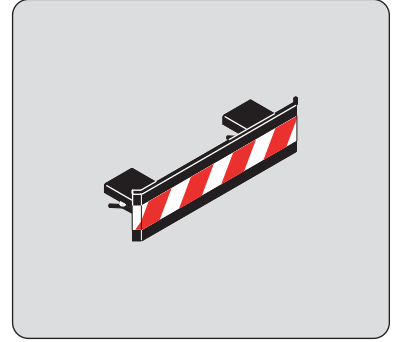

BUCKET PROTECTOR

Always ensure that the width of the protector you choose is less than or equal to the width of the bucket.

Width	REFERENCE	206734	206732	206730
		1375 mm	1500 mm	1650 mm
Width	REFERENCE	235854	206728	206726
		1850 mm	1950 mm	2000 mm
Width	REFERENCE	223771	223773	206724
		2050 mm	2100 mm	2150 mm
Width	REFERENCE	206099	206722	223775
		2250 mm	2450 mm	2500 mm

