



649034 EN (15/10/2020)

MRT-X Privilege Plus ST3A  
MRT Privilege Plus ST4



**USER MANUAL**  
*(ORIGINAL INSTRUCTIONS)*

**PREAMBLE:**  
**THIS MANUAL PROVIDES SUPPLEMENTARY INSTRUCTIONS THAT COMPLEMENT THOSE ALREADY PROVIDED IN THE MACHINE INSTRUCTION MANUAL.**

**IMPORTANT**

*Read this user manual carefully and understand it before using the lift truck.*

*It contains all the information on the operation and handling of the lift truck, on its equipment, and all the important provisions to follow.*

*This document also contains precautions for use and information about routine maintenance to guarantee that the lift truck is used safely and is reliable.*

**THIS SYMBOL MEANS:**



**CAUTION ! BE CAREFUL ! THE SAFETY OF THE USER AND OF THE LIFT TRUCK IS AT STAKE.**

- This manual has been written according to the list of equipment and technical characteristics provided during the design phase.
- The level of equipment on the lift truck depends on the optionals chosen and on the country where the carriage is placed on the market.
- Depending on the optionals and the commercialisation date of the lift truck, some accessories/ functions described in this manual may not be on the lift truck.
- Descriptions and figures are provided as an example and are not binding.
- MANITOU reserves the right to change its models and the related accessories without being obliged to update this manual.
- The MANITOU network, comprised only of qualified professionals, is at your disposal to answer any question.
- This manual is an integral part of the lift truck.
- Always keep it in its location in order to find it quickly when needed.
- In case of resale of the lift truck, provide the new owner with this manual.

FIRST EDITION	20/04/2018	
<b>UPDATE</b> <b>UPDATE</b>	<b>02/12/2019</b>	<b>4, 14, 15, 16, 17</b>
	<b>15/10/2020</b>	<b>3, 5, 7.</b>

MANITOU BF S.A a joint-stock company with a board of directors.  
Registered company office: 430 rue de l'Aubinière - 44150 Ancenis - France  
Share capital: 39,548,949 euro  
857 802 508 RCS Nantes.  
Tel.: +33 (0)2 40 09 10 11  
www.manitou.com

*This manual is provided for reference only. It may not be reproduced, copied, represented, purchased, transferred or distributed in any form, neither partially nor wholly. The diagrams, drawings, views, comments and instructions in this document, as well as its organisation, are the intellectual property of MANITOU BF. Any violation of the above is punishable by civil and criminal law. The logos and visual identity of the company are the property of MANITOU BF and may not be used without express formal authorisation in advance. All rights reserved.*

## DRIVING THE TELEHANDLER ON THE ROAD WITH BI-ENERGY SYSTEM

### Safety standards.

Drivers of telehandlers travelling on the road must follow general traffic regulations.

The telehandler must be compliant with the provisions of the Traffic Code in your country. Optional solutions are available if necessary. For more information, please contact your agent or dealer.

### Travelling on roads:

In order to follow traffic regulations, observe the current laws in the country of use pertaining to the weight bearing on each axle. In some countries, such as Italy and Germany, the BI-ENERGY system needs to be removed in order to comply with the law.

The maximum overall dimensions at the rear of the telehandler increase when the BI-ENERGY system is installed.

## ELECTROHYDRAULIC UNIT SPECIFICATIONS

### Main components of the BI-ENERGY system

Hydraulic unit (1):

- Hydraulic pump (1a)
- Three-phase electric motor with a maximum power of 18.5 kW - 400V/50Hz - IE3 (1b)
- Wall socket, 90° 3P + T 63A 6H (1c) for connecting to the external mains power by means of the supplied extension (1d).

Electrical panel (2):

- Transformer, 2500 VA, 400 VAC/24 VAC, three-phase (2a)
- Compact inverter, 18.5 kW - 25 hp, 400 VAC three-phase output (2b)
- Disconnecter switch (2c), 63 A, three-phase, IP65 Y/R for the electrical panel
- Illuminated emergency stop button, D. 60, IP66 (2d) to switch off the electrical panel
- Control panel with 4.3" touch display for the BI-ENERGY system (2e)
- PLC - programmable logic controller (2f).

Overview:

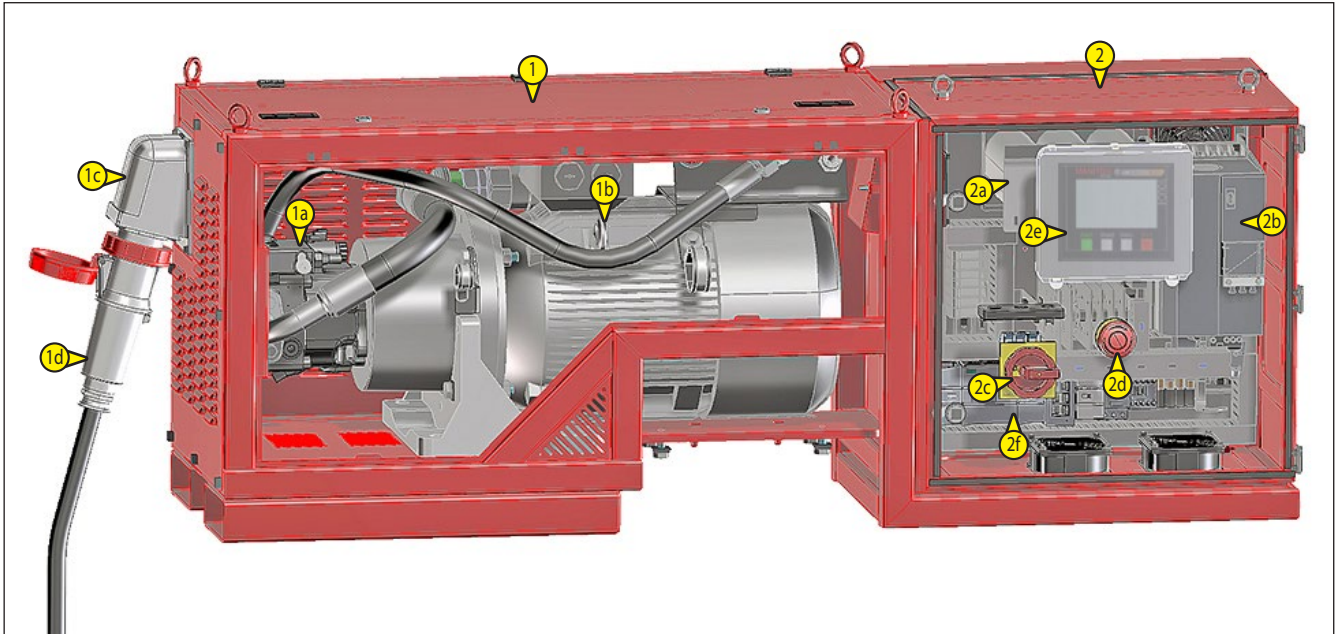

## CONNECTING TO THE POWER GRID

**⚠ THIS SYSTEM IS DESIGNED TO BE SUPPLIED WITH A VOLTAGE OF 400V.**

**⚠ Pay attention during connection to the power grid.**

**⚠ The BI-ENERGY electrohydraulic system installed on the MRT rotary telehandler is compliant with Machinery Directive 2006/42/EC.**

**⚠ Read the manufacturer's plate thoroughly. It shows the voltage, power, current and frequency values. Check these values match the supply required.**

**⚠ Do not accidentally touch naked wires or disconnected connections.**

**⚠ Never handle electrical parts with wet hands.**

**⚠ Keep the electrical cables and connections in good working order. Using equipment in bad conditions may cause electrocution and damage to the equipment.**

**⚠ Operations on the electrohydraulic unit must be performed only when it is off.**

**⚠ Electrical connections must be performed in compliance with current standards and regulations in the country the equipment is used in.**

**⚠ Do not use defective cables or that are temporarily badly insulated.**

## OPERATING LOGIC: BI-ENERGY + INVERTER

Telehandlers equipped with BI-ENERGY systems can also operate with the heat engine off.

When the BI-ENERGY mode is active:

- the machine only operates if it is connected to the mains power,
- the machine movements are driven by an electric motor (setup: min. 8.5kW – max. 18.5kW).

The electric motor is linked to an electric pump, which is connected to the machine hydraulic system.

### OPERATION IN BI-ENERGY MODE

1. Stabilise the machine
2. Stop the heat engine
3. Turn the ignition key to the "I" position to turn on the instrument panel in the cab
4. Connect the electric power cable (4a) to the power socket (4b) on the panel (4c)
5. Turn the disconnecter switch on the electrical panel (5)
6. The instrument panel display (6a) will turn on together with the status icons on the control panel (6b) in the cab (see the following pages)

**⚠ It is not possible to start the heat engine in this condition**

7. You can start the electric motor using:
  - a. Start on the panel
  - b. The ignition key in the cab
  - c. The Start button in the basket and/or radio remote control

In these conditions, you can move the boom using the pump driven by the electric motor.

**⚠ It is only possible to start the electric motor when the machine has been stabilised.**

To turn off the electric motor, press the Stop button on the electrical panel, return the ignition key in the cab to the zero position or press the emergency stop button on the radio remote control.



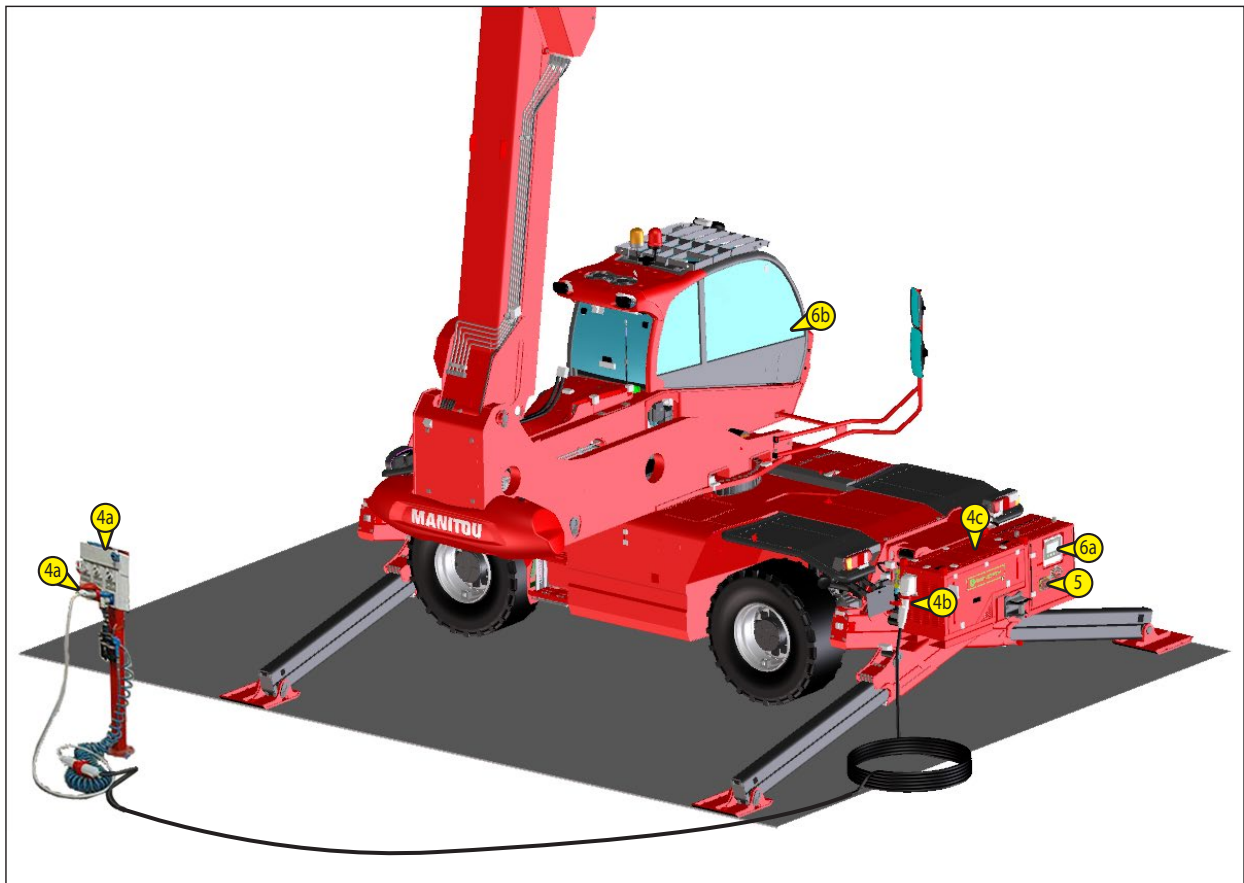













Turning the selector switch on the panel to 1 with the heat engine on, turns it off.



## BI-ENERGY SYSTEM STATUS ICONS DISPLAYED ON THE CONTROL PANEL IN THE CAB

The BI-ENERGY system communicates with the rotary telehandler and displays its operating state with an icon on the control panel.

Symbol overview:

Indicator	Status/ colour	Description/Function	Cause(s)
	 BLACK	Bi-energy system present	-
		the Bi-energy system is in standby or is off	-
	 GREEN	the Bi-energy is operating and there are no system alarms	-
	 RED	the Bi-energy system is in alarm and as a result, the system is stopped	there are many possibilities, such as the inverter has overheated, the battery charger circuit breaker has tripped, the emergency stop button on the Bi-energy electrical panel was pressed, etc. (see alarms)
	 RED - BLACK	the Bi-energy system has detected an anomaly in the mains power	mains blackout, one or more phases are missing, the line voltage is too low, the line voltage is too high (see alarms)
	 AMBER - BLACK	the Bi-energy system has detected that the hydraulic oil temperature is too high	this condition may be due to the ambient temperature being too high, plus intensive use of the system, plus clogged or dirty heat exchangers (air – oil)
	 BLUE - BLACK	the Bi-energy system has detected that the hydraulic oil temperature is too low	in this case, it is the ambient temperature that lowers the hydraulic oil temperature, so the first start-up is different from a standard start-up; in practice, the system configures itself to pre-heat the hydraulic oil before switching over to 100% performance
	 YELLOW - BLACK	the Bi-energy system has detected an unexpected communication fault with the rotating telehandler (in this case, it is the rotating telehandler that is no longer able to communicate with the Bi-energy system)	-

## CONTROL PANEL ON THE ELECTRICAL PANEL

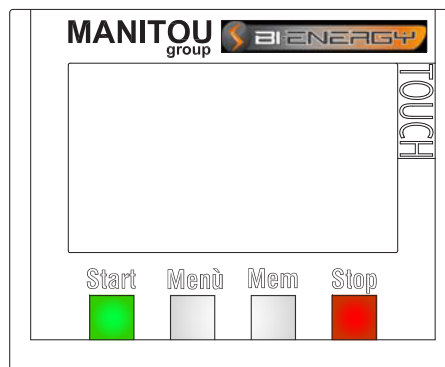

**Start** = button to start the system work cycle

**Menu** = button to open the system main menu or submenus

**Mem (ESC)** = button to force storing the variations set in the main menu or submenus

**Stop** = button to stop the system work cycle

**DISPLAY SCREENS**

1<sup>st</sup> opening screen (001)



2<sup>nd</sup> opening screen (002)



**MAIN SCREEN (003)**

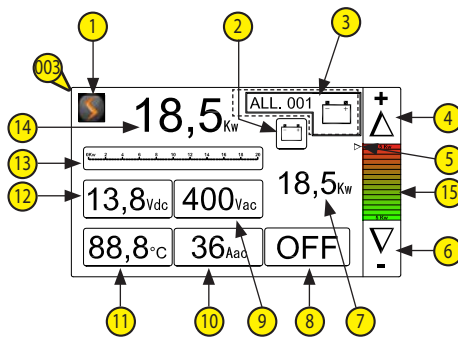

- 1 - Bi-energy symbol = press the Bi-energy icon on the monitor to open screen 002 for 3 seconds.
  - 2 - Battery charger status = the icon background colour indicates the battery charger status as follows:
    - Green icon background = batteries charged and battery charger off
    - Yellow icon background = batteries charging and battery charger trickle charging, with the “automatic battery charger” function enabled only.
    - Red icon background = batteries charging and battery charger on at full power to keep the batteries charged while using the machine intensively.
  - 3 - System alarm display area = this area displays any active system alarms, together with an alarm code and an icon that indicates the generic meaning of the alarm (open the alarm menu for a more detailed description of the alarm).
  - 4 - Button to increase the system power
  - 5 - Cursor to set the maximum system power
  - 6 - Button to decrement the system power = press the icon on the monitor, and the background will become negative; this button serves to reduce the total system consumption (7) on the scale (15); the cursor (5) moves each time it is pressed.
  - 7 - Set power scale = bargraph that shows the possible adjustment range, while the cursor (5) and numerical field (7) indicate the set value.
  - 8 - System status = the icon indicates the machine status from the following three:
    - OFF = system off; when this appears black on a red background, you can turn off the system with the display button or by turning the ignition key.
    - SBY = system in standby; when this appears black on a yellow background, the system enters standby mode if you do not request any movement for a certain period of time.
    - ON - system on (operating); when this appears black on a green background, the system is operating.
  - 9 - Average power supply voltage
  - 10 - Effective current consumption in Amps
  - 11 - Hydraulic oil temperature
  - 12 - Battery voltage
  - 13 - Bargraph of the effective system power consumption = graphical indicator that is directly proportional to the effective system power consumption
  - 14 - Effective system power consumption
  - 15 - Maximum system power setting = use buttons (4) and (6) to set the maximum system power consumption. You can set this value to the theoretical power consumption that must not be exceeded.
- Note = if necessary, set a lower maximum power consumption if the available mains power line cannot support a load of 18.5 kW.

**⚠️ (\*) The minimum value to be set in order to use the hydraulic movements of the rotary telehandler must be ≥ 8.5kW.**

**MENU SELECTION SCREEN (004)**

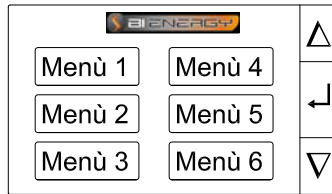

- This screen displays the menus that you can browse.
- Menu 1 – SYSTEM DIAGNOSTICS (system I/O data)
  - Menu 2 = SYSTEM WORKING HOURS
  - Menu 3 = LANGUAGE SELECTION
  - Menu 4 = SYSTEM ALARMS
  - Menu 5 = SYSTEM BATTERY CHARGER MANAGEMENT
  - Menu 6 = SPECIAL SYSTEM FUNCTIONS (with password only)

Press the  $\Delta/\nabla$  touch keys to scroll through the menus, and press the  $\leftarrow$  touch key to open the desired menu.  
 Note: if the selected screen remains inactive for more than 10 seconds, the system automatically returns to the main screen (003).

**MENU 1 – SYSTEM DIAGNOSTICS (system I/O data)**

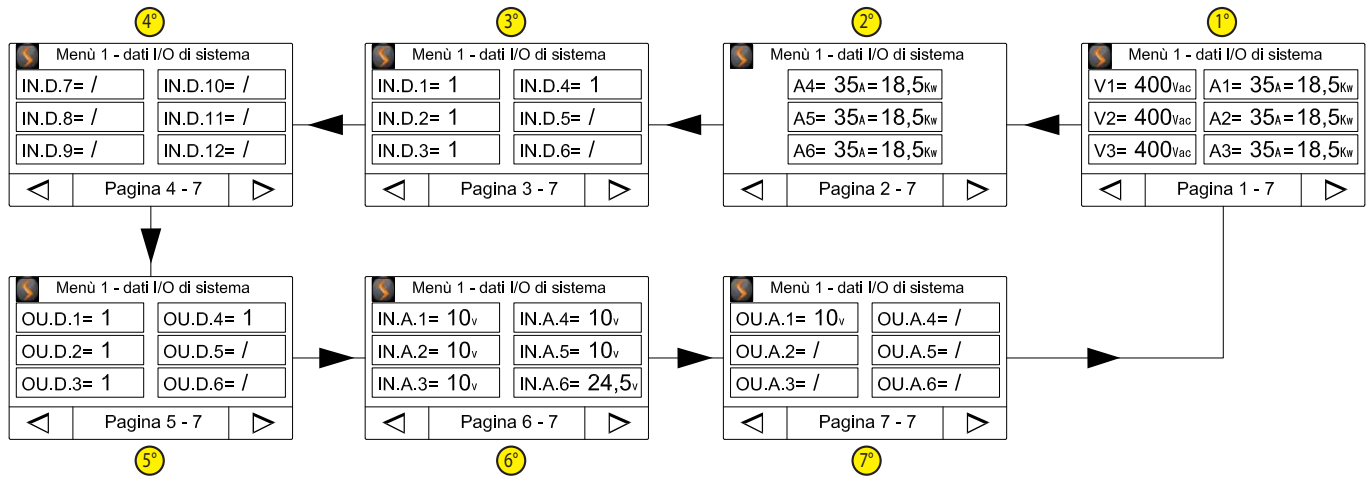

Press the  $\triangleleft/\triangleright$  touch keys to scroll through the seven screens (Pages 1-7 > 2-7 > 3-7.....).

1st diagnostics screen:

V1 + V2 + V3 = direct voltage reading for each phase; these values are taken from the inverter logic.  
 A1 + A2 + A3 = power consumption in kW of each phase of the electric motor, plus a conversion into Amps for each phase; these values are taken from the inverter logic.

2nd diagnostics screen:

A4 + A5 + A6 = power consumption in kW of each phase of the Bi-energy system, plus a conversion into Amps for each phase; these values are taken from three current transformers installed immediately after the system main disconnector switch.

3rd diagnostics screen:

This screen shows the logic state of the first 6 digital inputs on the PLC.

4th diagnostics screen:

This screen shows the logic state of the next 6 digital inputs on the PLC.

5th diagnostics screen:

This screen shows the logic state of the digital outputs on the PLC.

5th diagnostics screen:

This screen shows the logic state of the digital outputs on the PLC.

6th diagnostics screen:

This screen shows the logic state of the analogue inputs on the PLC plus the additional module.

7th diagnostics screen:

This screen shows the logic state of the analogue output on the additional module controlled by the PLC.

**MENU 2 – SYSTEM WORKING HOURS**

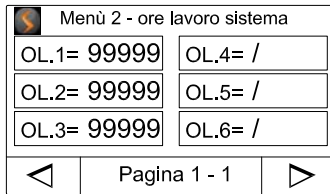

This screen displays the working hours of the system. The times are:  
 - OL.1 = total working hours of the Bi-energy system.  
 - OL.2 = working hours of the electric motor.  
 - OL.3 = working hours of the battery charger.  
 Note: use the arrow to return to the menu selection screen (004).

**MENU 3 – LANGUAGE SELECTION**



This screen displays the languages available in the system; selecting a language applies it to all of the displays screens. Press the touch keys to scroll through the languages, and press the touch key to set the desired language.

**MENU 4 – SYSTEM ALARMS**

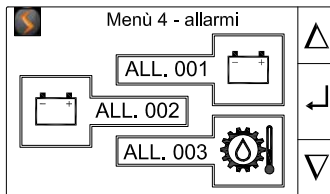

This screen summarizes and displays all of the active system alarms. Depending on the number of alarms, there will be a number of pages with 3 alarms on each.

Press the touch keys to select the alarm, and press the to confirm and open a screen with details of the alarm type and likely causes.

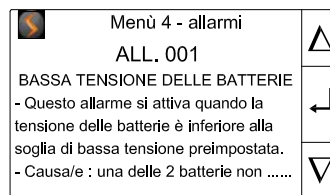

Note: in the alarm details screen, press the touch keys to scroll through the text, and press the key on the control panel to return to the previous screen.

**Alarm list:**

- AL. 001 = low battery voltage
- AL. 002 = high battery voltage
- AL. 003 = hydraulic oil temperature (oil too cold threshold)
- AL. 004 = hydraulic oil temperature (oil too hot threshold)
- AL. 005 = mains voltage low or missing
- AL. 006 = mains voltage too high
- AL. 007 = incorrect command from the master control unit (e.g. simultaneous start and stop commands).
- AL. 008 = emergency stop button pressed on the Bi-energy electrical panel.
- AL. 009 = battery charger circuit breaker
- AL. 010 = battery charger contactor fault
- AL. 100 = CAN communication error (appears when there is no CAN connection between the PLC and the machine).
- AL. 200 = communication error between the PLC and the inverter
- AL. 300 = communication error between the PLC and the display [hexadecimal]

Alarm descriptions:

Alarm Type	Description	Cause(s)	Working condition
AL. 001	This alarm is active when the battery voltage is lower than the preset low voltage threshold	one of the two batteries is not connected or not working, the batteries are too old and no longer recharge, a fuse has blown on the machine	in this case, the system attempts to keep the PLC so that it can continue working, until a certain power supply threshold is exceeded, which shuts down the PLC; if the power supply fuse blows, the logic shuts down and the Bi-energy system stops.
AL. 002	this alarm is active when the battery voltage is higher than the preset voltage threshold	the battery charger sends a voltage to the batteries that is too high	in this case, the system attempts to keep the PLC active, but this condition is dangerous for the PLC HW; the inverter and all of the components and modules that are sensitive to the 24 Vdc power supply risk being permanently damaged
AL. 003	this alarm is active when the hydraulic oil temperature is lower than the preset threshold	the ambient temperature is lower than the set threshold	
AL. 004	this alarm is active when the hydraulic oil temperature is higher than the preset threshold		the set working conditions require a performance that is too high for the system, or the working ambient temperature is very high, which contributes to increasing system temperature over the set threshold
AL. 005	this alarm is active when the mains voltage is lower than the preset threshold	the voltage is too low or one or more mains power phases are missing	
AL. 006	this alarm is active when the mains voltage is higher than the preset threshold	the voltage is too high; normally this is a mains power problem	
AL. 007	this alarm appears when the "start" and "stop" commands are sent to the bi-energy system simultaneously	one or more operators give the start and stop commands at the same time	
AL. 008	when the operator uses the button on the electrical panel door to stop the electric motor or the system due to an emergency condition or in the event of imminent danger.	this alarm is only active when the emergency stop button on the electric panel is pressed	
AL. 009	this alarm is active when the PLC detects that the circuit breaker that protects all of the components of the battery charger built into the electrical panel has tripped.	this alarm is active when the line protection circuit breaker detects a short circuit or overload condition in the battery charger.	
AL. 010	when the battery charger contactor is not on	defective contactor coil	
AL. 100	this alarm is active when there is no CAN connection between the PLC and the machine	the PLC may not be powered, a fuse on the machine has blown and disconnected the power supply, or the data cable is not connected correctly	
AL. 200	this alarm is active when there is no CAN connection between the PLC and the inverter	the PLC or the inverter may not be powered, a fuse on the MRT has blown and disconnected the power supply, or the data cable is not connected correctly	
AL. 300	this alarm is active when there is no CAN connection between the PLC and the display	the PLC or the display may not be powered, a fuse on the MRT has blown and disconnected the power supply, or the data cable is not connected correctly	

**MENU 5 – SYSTEM BATTERY CHARGER MANAGEMENT**

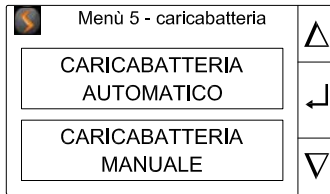

Press the  $\Delta$ / $\nabla$  touch keys to select one of the two battery charger operating modes, and press the  $\leftarrow$  to confirm and activate the selection.

Note: press the Mem key on the control panel to return to the previous screen.

**Description of the two battery charger operating modes:**

- Manual battery charger: use this mode to activate the battery charger during working hours and use it as a power supply so that the MRT utilities do not discharge the batteries. Even if there is mains power when the machine is not in use or at night, the battery charger does not operate.
- Automatic battery charger: this mode activates the battery charger during working hours as for “manual battery charger” mode, while if there is mains power when the machine is not in use or at night, it keeps the batteries charged like a real battery/trickle charger. This function is very useful for machines that have to work in low-temperature environments or with old batteries that do not hold their charge well while not in use.

Battery charger status indicator on the main screen (003):

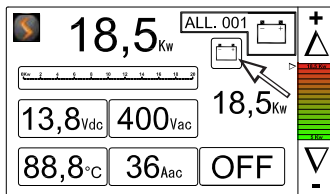

- If the indicator is red, it means that the battery charger is currently charging the batteries; in this condition, it can supply its whole current capacity to the batteries and machine utilities.
- If the indicator is yellow, it means that the battery charger is trickle charging the batteries while the machine is not in use or at night; this function is only active when the “Automatic battery charger” mode is selected
- If the indicator is green, it means that the battery charger has charged the machine batteries to a good level; in this condition, the battery charger is momentarily in standby.  
*Note: in this condition, the battery charger reactivates if there is a heavy current demand (working condition) or the batteries discharge while the machine is not in use or at night.*

**MENU 6 – SPECIAL SYSTEM FUNCTIONS**

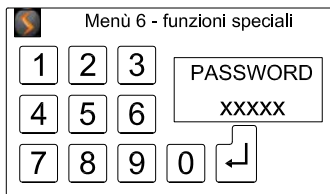

Password-protected configuration screen. Contact your agent or dealer.

# USE

## BI-ENERGY SYSTEM START:

- from cab,
- from basket keypad and radiocontrol,
- from control panel of the electrical panel.

From the cab: to start the system from the cab, turn the ignition key to the “start engine (III)” position; the system will start if there is mains power and the main disconnect switch is on.

*Important note: if there is no mains power when you turn the ignition key to the “start engine (III)” position, the machine heat engine will start rather than the electric motor.*

From the basket and radiocontrol: to start the Bi-energy system from the basket, just perform the heat engine start-up procedure using the push-button panel installed in the basket.

From the Bi-energy control panel: to start the system from the Bi-energy control panel, the system must have received at least one engine start message, then just press the green “Start” key below the display.

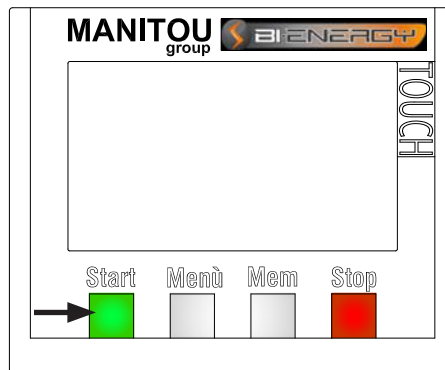

## SYSTEM SLEEP MODE (HOW AND WHEN):

Once the Bi-energy system has been started from the cab, basket or control panel display, it can be used to move the machine turret; if you make no movement requests for more than 5 minutes (default setting), the system automatically activates “sleep mode”, which automatically stops the electric motor (energy saving mode). In this condition, the Bi-energy logic remains active and if you request movement, it exits from “sleep mode” and restarts the electric motor so that you can continue working.

## STOPPING THE SYSTEM FROM THE CAB OR CONTROL PANEL ON THE ELECTRICAL PANEL.

- From the cab: to stop the Bi-energy system from the cab, just turn the ignition key to the OFF position (panel fully off).
- From the basket: to stop the Bi-energy system from the basket, just press the emergency stop button on the push-button panel, as you do normally to stop the heat engine (or diesel engine).
- From the Bi-energy panel: to stop the system from the Bi-energy control panel, just press the red key below the display.

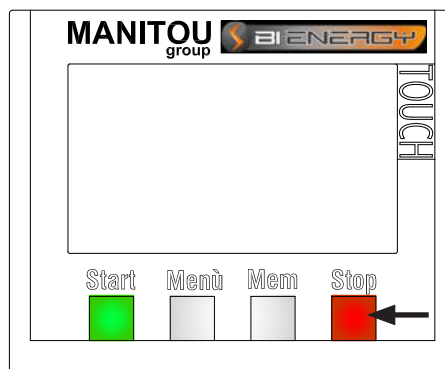

## STARTING THE SYSTEM WHEN THE HYDRAULIC OIL IS TOO COLD.

The Bi-energy system has a temperature probe for the hydraulic oil. This probe is located on the hydraulic pump intake pipe, and serves to monitor the temperature of the hydraulic oil that is sucked up from the main tank.

If the system detects that the hydraulic oil temperature is below the minimum temperature threshold (set with a parameter), it automatically limits the pump displacement to the minimum until the temperature rises above the preset threshold.

**System behaviour below the minimum temperature threshold:**

- it reduces the hydraulic pump displacement to the minimum to limit the risk of breaking the pump,
- it leaves the movements active, but limits their speed,
- it waits for the oil to heat up and exceed the minimum temperature threshold.

When the system detects that the temperature has risen above the preset threshold, it continues normal operation according to the user settings.

**SYSTEM OPERATING WHEN THE HYDRAULIC OIL IS TOO HOT**

If the system detects that the hydraulic oil temperature is above the maximum temperature threshold (set with a parameter), it automatically limits the pump displacement to the minimum until the temperature drops below the preset threshold.

**SYSTEM BEHAVIOUR ABOVE THE MINIMUM TEMPERATURE THRESHOLD:**

- it reduces the pump displacement to lower the oil temperature,
- it leaves the movements active, but limits their speed,
- it waits for the oil temperature to drop below the maximum temperature threshold.

When the system detects that the temperature has dropped below the preset threshold, it continues normal operation according to the user settings.

# REMOVING AND INSTALLING THE ELECTROHYDRAULIC UNIT OF THE ROTARY TELEHANDLER

## REMOVAL PROCEDURE

- Position the rotary telehandler on the tires and on a flat solid surface,
- turn the turret (1) to have safe and wide working space,
- stop the I.C. engine or the electrohydraulic unit,

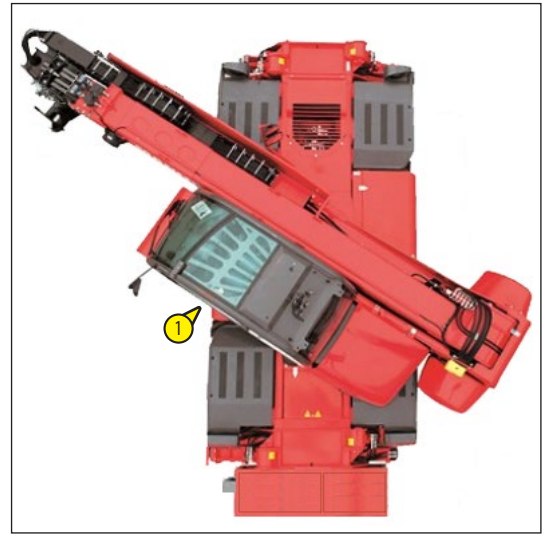

- disconnect the connection between the power grid and the electrohydraulic unit, if connected (2),

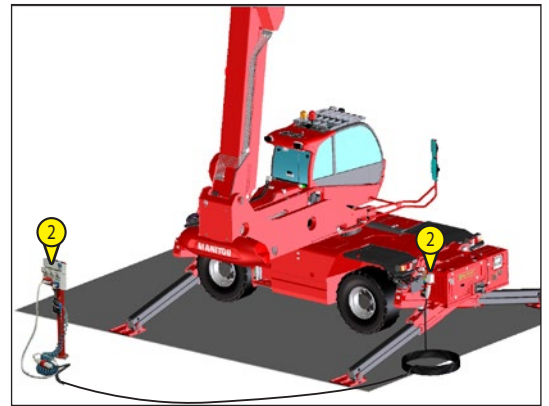

- open the door (3) of the electrohydraulic unit compartment (3b), using the supplied metal key (3a), to access the hydraulic (5) and electrical (6) connections,

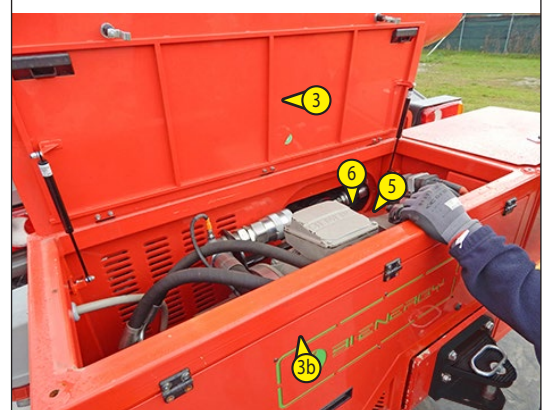
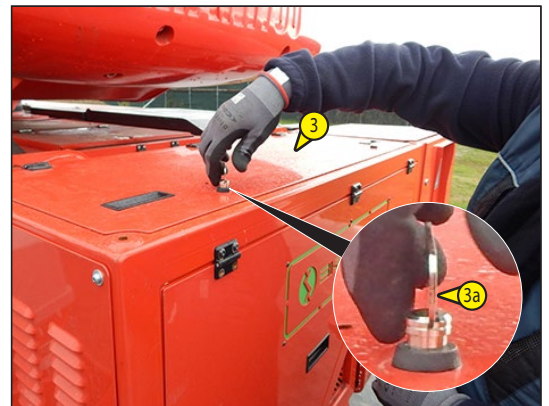

- disconnect the four hydraulic pipes (5) and the two power sockets (6) which connect the electrohydraulic unit to the rotary telehandler,

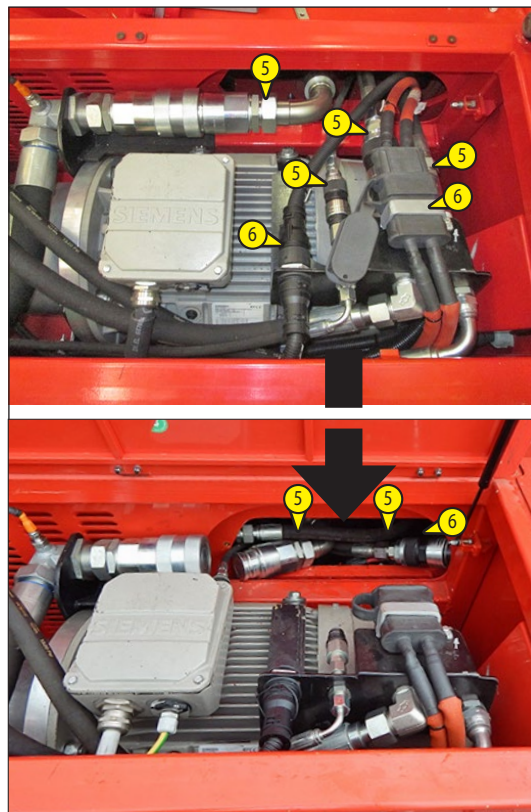

- position the four hydraulic pipes (5) and the two power sockets (6) in the relevant pipe holder (7a) and socket holder (7b) located within the frame (according to the model of the rotary telehandler),

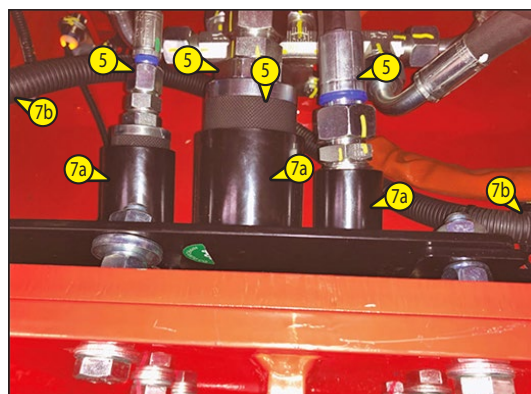

- close the door (3) of the electrohydraulic compartment (3b),
- position a forklift truck (4) to the side of the electrohydraulic unit and insert the forks (4) fully into the relevant lifting slots (4a),

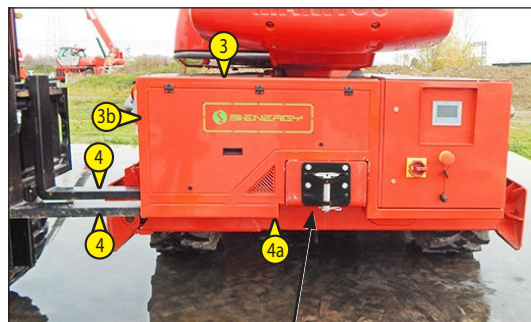

- unscrew the four screws (8) securing the electrohydraulic unit to the support (9) on the rotary telehandler, using a 21 mm (0.8in) hex-socket spanner;

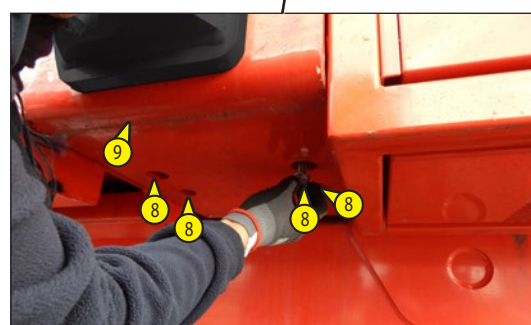

- lift the forks (4) of the truck slowly and vertically to remove the electrohydraulic unit (10) from the two centring holes (9) located on the support secured to the rotary telehandler,
- lift and move the electrohydraulic unit (10) just enough to prevent contact with the rotary telehandler and any surrounding obstacles,



- slowly place the electrohydraulic unit (10) on a flat base and pull out the forks (4) of the truck.

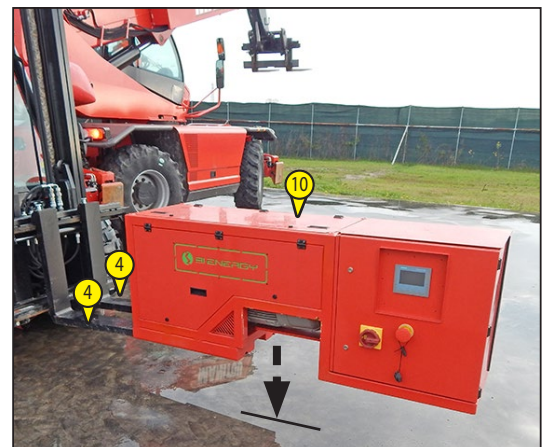

remove the pull hook (15) from the support by unscrewing the four screws (16) that secure it,

- use a 22mm (0.86in) spanner to unscrew the four fastening screws (16),
- hold support (9) with a lift truck and remove it from the rotary telehandler by unscrewing the six fastening screws (17), using a 22mm (0.86in) spanner.
- place the support on a flat solid base,

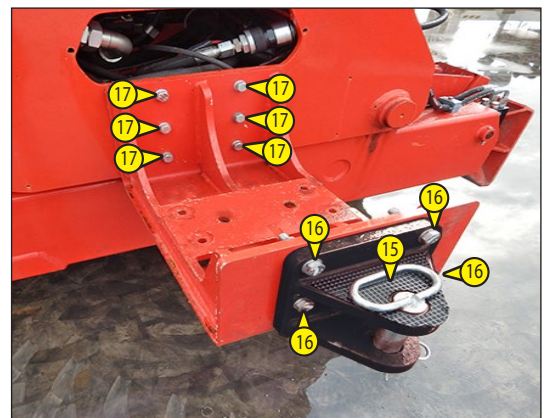

- take the closing plate (12) accessing the hydraulic (5) and electrical (6) connections from the storage compartment behind the cab (11) on the rotary telehandler,
- use two 8mm (0.3in) hex spanners to unscrew the two screws (13) locking the plate (12) to the storage compartment (11),
- position and secure the plate (12) to the frame using the same screws (13) that secured it to the storage compartment behind the cab (11),
- use a 8mm (0.3in) hex spanner to tighten the two screws (13),

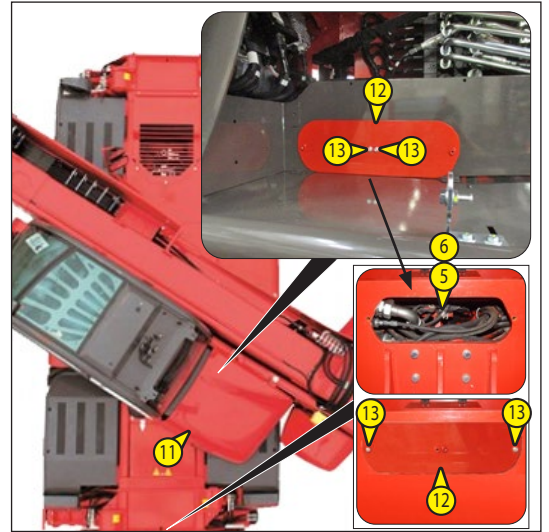

- reinstall the pull hook (15) on the rotary telehandler, tightening the four fastening screws (16), with a 22mm (0.86in) hex spanner,
- realign the turret of the rotary telehandler.

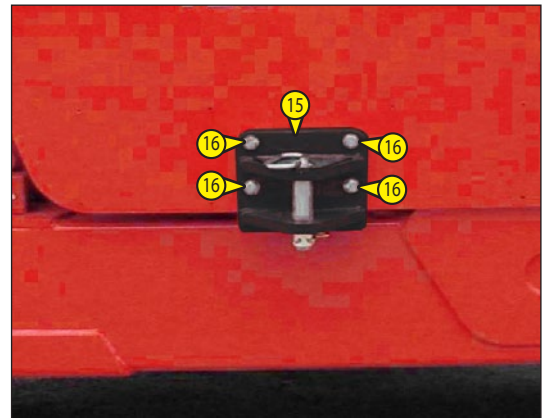

**INSTALLATION PROCEDURE**

To install the electrohydraulic unit on the rotary telehandler, perform the operations described in the REMOVAL PROCEDURE in inverse order.

**WARNING:** when installing the four hydraulic pipes "A" and the two electrical sockets "B" (see images below), proceed according to the sequence described and illustrated below.

SEQUENCE: A1 -> A2 -> A3 -> A4 -> B1 -> B2

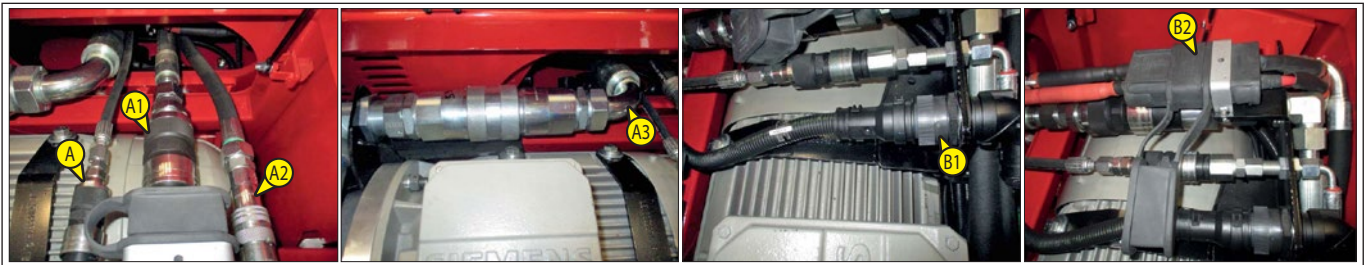

## MAINTENANCE SCHEDULE

General checks and maintenance on the Bi-energy electrohydraulic unit.

For your safety, follow the mandatory inspection and checking instructions **before starting a work cycle**.

### DAILY OR EVERY 10 HOURS OF SERVICE

- Visually check the condition of the external structure and internal hydraulic and electric components.
- Check the electrical system.
- Visually check the hydraulic connections and the condition of the hoses.
- Check that the emergency stop button on the electrical panel is working.
- Check that the control panel on the electrical panel is working

**⚠ Do not attempt to replace or repair any parts without the presence of a qualified Manitou technician.**

*Any tampering not authorised by Manitou will invalidate the warranty.*

### EVERY 50 HOURS OF SERVICE

*To be carried out weekly, if the truck has been operated for less than 50 hours during the week.*

**⚠ In the event of intensive use in an extremely dusty or oxidising atmosphere, reduce this interval to 10 working hours or every day.**

- Blow the fans and fan filters "1" (x 4) on the electrical panel with a jet of air. Check that the fan filters are not damaged, and replace them with new ones if they are: Manitou reference 53019622
- Blow the electrohydraulic unit with a jet of air.

