



52772520 EN-USM3 (B-04/2024)

MT 735 75D ST5 S1
MT 935 75D ST5 S1
MT 1135 75D ST5 S1
MT 1335 75D ST5 S1
MT 1335 100D ST5 S2

OPERATOR'S MANUAL
(ORIGINAL MANUAL)

IMPORTANT

Carefully read and understand this instruction manual before using this machine.

It contains all information relating to operation, handling and equipment, as well as important recommendations to be followed.

This document also contains precautions for use, as well as information on the service and routine maintenance required to ensure the machine's continued reliability and safety of use.

WHENEVER YOU SEE THIS SYMBOL, IT MEANS:



NOTE! BE CAREFUL! YOUR SAFETY, THAT OF OTHERS, OR THE SAFETY OF THE MACHINE IS AT RISK.

- This manual has been produced based on the equipment list and technical characteristics given at the time of its design.
- The machine's equipment level depends on the options chosen and the country of sale.
- Depending on the machine's options and the date of sale, certain equipment or functions described in this manual may not be present on this machine.
- Descriptions and figures are nonbinding.
- MANITOU reserves the right to change its models and their equipment without being required to update this manual.
- The MANITOU network, consisting exclusively of qualified professionals, is available to answer all your questions.
- This manual is an integral part of the machine.
- It is to be kept in its storage location at all times for ease of reference.
- Give this manual to the new owner if the machine is resold.

CALIFORNIA PROPOSITION 65 WARNINGS

WARNING

This product can expose you to lead which is known to the State of California to cause cancer and birth defects or other reproductive harm.

For more information go to www.P65Warnings.ca.gov

WARNING

Breathing diesel engine exhaust exposes you to chemicals known to the State of California to cause cancer and birth defects or other reproductive harm.

- Always start and operate the engine in a well-ventilated area.
- If in an enclosed area, vent the exhaust to the outside.
- Do not modify or tamper with the exhaust system.
- Do not idle the engine except as necessary.

For more information go to www.P65Warnings.ca.gov/diesel

SILICA DUST HAZARD

Exposure to crystalline silica (found in sand, soil and rocks) has been associated with silicosis, a debilitating and often fatal lung disease. Comply with all applicable rules and regulations for the workplace. Wear approved respiratory protection or use water spray or other means if there is no other way to control the dust.

A Silica rule "29 CFR 1929.1153" by the U.S. Occupational Safety and Health (OSHA) indicates a significant risk of chronic silicosis for workers exposed to inhaled crystalline silica over a working lifetime. Refer to the rule for more information regarding exposure limits and hazard prevention.



1st EDITION

B-04/2024

UPDATED

This brochure and all the information contained herein, including drawings, are the intellectual property of Manitou BF and/or its subsidiaries (hereinafter "Manitou Group") and are confidential. Any reproduction, publication or communication to third parties of all or part of the brochure without the express written consent of Manitou Group is strictly prohibited. Any violation will subject you to legal action. The logos and visual identity of the company are the property of Manitou Group and may not be used without express formal authorization. All rights reserved.

All trademarks mentioned, whether registered or not, are and shall remain the property of MANITOU BF or its owner respectively.

Any reproduction, source code access, decompilation, modification, copy (other than backup copies), correction of errors, transmission or distribution of any software built into Manitou Group machines is strictly prohibited.

In the event that the measures above nevertheless prove essential to enable use of the software, in accordance with its destination, or to obtain the information required for interoperability with other software created independently, the user should contact Manitou Group in advance and may, at its sole discretion, take the necessary measures or give access to only the information strictly necessary for interoperability.

Any breach of these requirements is likely to constitute a counterfeiting offense subject to legal action by Manitou Group.

Connected Manitou Group machines are equipped with boxes that collect technical data on the machines (such as geo-tracking data or data on component operation). This data, which is organized, processed and enhanced by algorithms and expertise proprietary to Manitou Group, constitutes, whether or not in conjunction with other independent elements, a protected database under applicable intellectual property laws and regulations.

It is strictly forbidden to have access to all or part of this database and to use the data (including in the event of accidental access) without explicit prior authorization from Manitou Group. In the event that Manitou Group authorizes a Manitou Group machine user to access all or part of this database, Manitou Group, as producer of this database, cedes to the user only a right to personal, non-exclusive, nontransferable use of the database, and only by access to an information technology platform hosted by a server owned or controlled by Manitou Group.

In any case, the following are strictly prohibited:

- any extraction, reproduction, representation, reuse through provision to the public, distribution, transfer, permanent or temporary, on any medium, by any means, and in any form whatsoever, of all or of a qualitatively or quantitatively substantial part of the contents of this database,*
- any extraction, reproduction, representation, reuse through provision to the public, distribution, transfer, repeated or systematic of qualitatively or quantitatively insubstantial parts of the content of the database during operations manifestly exceeding normal use of the database by the user of the machine for his own needs,*
- any use of means to bypass technical protection measures for databases or the software source code embedded in the boxes, in accordance with the applicable intellectual property laws and regulations.*

The latest applicable version of this document is available upon request.

Only the computerized version is managed.

MANITOU BF S.A. Public limited company with a board of directors.

Head office: 430 rue de l'Aubinière - 44150 Ancenis - France

Share capital: €39,548,949

Entered in the Nantes Trade and Companies Register under number 857 802 508.

Tel.: +33 (0) 2 40 09 10 11

www.manitou.com

1 - OPERATING AND SAFETY INSTRUCTIONS

2 - DESCRIPTION

3 - MAINTENANCE

4 - ATTACHMENTS

MT 735 75D ST5 S1



MT 935 75D ST5 S1



MT 1135 75D ST5 S1
MT 1335 75D ST5 S1
MT 1335 100D ST5 S2



1 - OPERATING AND SAFETY INSTRUCTIONS

1 - OPERATING AND SAFETY INSTRUCTIONS

INSTRUCTIONS TO THE COMPANY MANAGER

1-4

THE SITE	1-4
THE OPERATOR	1-4
THE MACHINE	1-4
A - SUITABILITY OF THE MACHINE FOR THE TASK	1-4
B - ADAPTING THE MACHINE TO USUAL ENVIRONMENTAL CONDITIONS	1-4
C - MODIFYING THE MACHINE	1-5
D - FRENCH ROAD TRAFFIC RULES	1-5
E - MACHINE CAB PROTECTION	1-5
INSTRUCTIONS	1-6
MAINTENANCE	1-6

INSTRUCTIONS FOR THE OPERATOR

1-8

FOREWORD	1-8
GENERAL INSTRUCTIONS	1-8
A - OPERATOR'S MANUAL	1-8
B - AUTHORIZATION FOR USE IN FRANCE	1-8
C - MAINTENANCE	1-8
D - TIRES	1-8
E - MODIFYING THE MACHINE	1-9
F - LIFTING PEOPLE	1-9
OPERATING INSTRUCTIONS UNLADEN AND LADEN	1-10
A - BEFORE STARTING UP THE MACHINE	1-10
B - AVAILABLE IN THE DRIVER'S CAB	1-10
C - ENVIRONMENT	1-10
D - VISIBILITY	1-11
E - STARTING THE MACHINE	1-12
F - OPERATING THE MACHINE	1-12
G - STOPPING THE MACHINE	1-14
H - DRIVING THE MACHINE ON THE PUBLIC HIGHWAY	1-15
INSTRUCTIONS FOR HANDLING A LOAD	1-16
A - CHOICE OF ATTACHMENTS	1-16
B - WEIGHT OF LOAD AND CENTER OF GRAVITY	1-16
C - LONGITUDINAL STABILITY INDICATOR	1-16
D - TRANSVERSE ATTITUDE OF THE MACHINE	1-17
E - PICKING UP A LOAD ON THE GROUND	1-17
F - PICKING UP AND PUTTING DOWN A HIGH LOAD ON TIRES	1-18
G - PICKING UP AND PUTTING DOWN A HIGH LOAD ON STABILIZERS	1-20
H - PICKING UP AND PUTTING DOWN A SUSPENDED LOAD	1-22
I - TRAVELING WITH A SUSPENDED LOAD	1-22
INSTRUCTIONS FOR USE AS A LOADER	1-23
A - LOADING	1-23
B - BACKFILLING	1-23
INSTRUCTIONS FOR USING THE MOBILE ELEVATING WORK PLATFORM	1-24
A - AUTHORIZATION FOR USE	1-24
B - SUITABILITY OF THE PLATFORM FOR THE JOB	1-24
C - PROVIDED ON THE PLATFORM	1-24
D - USING THE PLATFORM	1-25
E - ENVIRONMENT	1-26
F - MAINTENANCE	1-26
INSTRUCTIONS FOR USING THE RADIO-CONTROL	1-27
HOW TO USE THE RADIO-CONTROL	1-27
PROTECTIVE DEVICES	1-27

MACHINE MAINTENANCE INSTRUCTIONS

1-28

GENERAL INSTRUCTIONS	1-28
PLACING THE JIB SAFETY WEDGE	1-28
FITTING THE WEDGE	1-28
REMOVING THE WEDGE	1-28
MAINTENANCE	1-28
MAINTENANCE LOGBOOK	1-28
LUBRICANT AND FUEL LEVELS	1-29
HYDRAULICS	1-29
ELECTRICITY	1-29
WELDING	1-29
WASHING THE MACHINE	1-29
TRANSPORTING THE MACHINE	1-29

PROLONGED MACHINE SHUTDOWN

1-30

INTRODUCTION	1-30
PREPARATION OF THE MACHINE	1-30
DEF (Diesel Exhaust Fluid) TANK	1-30
PROTECTING THE ENGINE	1-30
MACHINE PROTECTION	1-30
RETURNING THE MACHINE TO SERVICE	1-31

DISPOSING OF THE MACHINE

1-32

RECYCLING OF MATERIALS	1-32
METALS	1-32
PLASTICS	1-32
RUBBER	1-32
GLASS	1-32
ENVIRONMENTAL PROTECTION	1-32
WORN OR DAMAGED PARTS	1-32
USED OIL	1-32
USED BATTERIES.	1-32

INSTRUCTIONS TO THE COMPANY MANAGER

THE SITE

Proper management of the machine's area of travel will reduce the risk of accidents:

- ground not unnecessarily uneven or obstructed,
- no excessive slopes,
- pedestrian traffic controlled, etc.

THE OPERATOR

- Only qualified, authorized personnel can use the machine. This authorization is given in writing by the appropriate person in the establishment where the machine is to be used and must be carried permanently by the operator.

⚠ IMPORTANT ⚠

Experience has shown that there are a number of inappropriate ways in which the machine might be used. Such foreseeable misuse, of which the main examples are listed below, are strictly forbidden.

- The foreseeable abnormal behavior resulting from ordinary negligence, but not from any intentional misuse of the equipment.

- The reflex reactions of a person in the event of a malfunction, incident, fault, etc. during operation of the machine.

- Behavior resulting from application of the "principle of least effort" when performing a task.

- *For certain machines, the foreseeable behavior of such persons as: apprentices, teenagers, handicapped persons, trainees tempted to drive a machine, operators tempted to operate a machine to win a bet, in competition or for their own personal experience.*

The person in charge of the equipment must take these criteria into account when assessing whether or not a person will make a suitable driver.

THE MACHINE

A - SUITABILITY OF THE MACHINE FOR THE TASK

- MANITOU has ensured that this machine is suitable for use under the standard operating conditions defined in this operator's manual, with a **STATIC TEST COEFFICIENT OF 1.25** and a **DYNAMIC TEST COEFFICIENT OF 1**, as specified in harmonized standard **EN 1459** for variable reach machines.
- Before commissioning, the company manager must make sure that the machine is appropriate for the work to be done, and perform certain tests (in accordance with current legislation).

B - ADAPTING THE MACHINE TO USUAL ENVIRONMENTAL CONDITIONS

- Our machines are designed to be used within a temperature range of -18 °C (-0.4°F) to +43 °C (109.4°F).
- In addition to the standard equipment fitted on your machine, many options are available, such as: road lighting, stop lights, rotating beacon light, reverse lights, front worklight, rear worklight, boom head worklight, etc. (depending on machine model).
- The operator must take into account the operating conditions to specify the machine's signaling and lighting equipment. Consult your dealer.
- Take into account the climatic and atmospheric conditions of the site of utilization.
 - Protection against frost (↖ 3 - MAINTENANCE: LUBRICANTS AND FUEL).
 - Adaptation of lubricants (ask your dealer for information).
 - Engine filtration (↖ 3 - MAINTENANCE: FILTER CARTRIDGES AND BELTS).

⚠ IMPORTANT ⚠

For operation under average climatic conditions, i.e. between -15 °C and +35 °C, correct levels of lubricants in all the circuits are checked in production. -15 °C to +35 °C

For operation under more severe climatic conditions, before starting up, drain all circuits, then fill using lubricants suitable for the ambient temperatures.

The same applies to the coolant.

- Take into account the fire risk associated with use in dusty and flammable conditions (e.g. straw, flour, sawdust, organic waste, etc.).
- MANITOU recommends fitting your machine with an individual fire extinguisher to neutralize any fire as soon as it starts. Solutions exist, consult your dealer.

⚠ IMPORTANT ⚠

Your machine is designed for outdoor use under normal atmospheric conditions and indoor use in suitably aerated and ventilated premises. For use in very dusty atmospheres (flour, sawdust), solutions are available. Consult your dealer.

It is prohibited to use the machine in areas where there is a risk of fire or which are potentially explosive (e.g. refineries, fuel or gas depots, stores of inflammable products, etc.).

Special equipment is available for use in such areas (ask your dealer for information).

Our machines comply with Directive 2014/30/EU (2015/208/EU for our type-approved "TRACTOR" machines) concerning electromagnetic compatibility (EMC), and with the corresponding harmonized standard EN 12895. Their correct operation is no longer guaranteed if they are used within areas in which the electromagnetic fields exceed the limit specified by this standard (20 V/m).

- Directive 2002/44/EC requires company managers to not expose their employees to excessive vibration doses. There is no recognized code of measurement for comparing the machines of different manufacturers. The actual doses received cannot therefore be measured under actual operating conditions at the user's premises.
- The following are some tips for minimizing these vibration doses:
 - Select the most suitable machine and attachment for the intended use.
 - Adapt the seat adjustment to the operator's weight (**depending on machine model**) and maintain it in good condition, as well as the cab suspensions. Inflate the tires in accordance with recommendations.
 - The seat is an essential way of reducing the vibrations transmitted to the operator. In the event of seat replacement, please contact MANITOU.
 - Ensure that the operators adapt their operating speed to suit the conditions on site.
 - As far as possible, arrange the site in such a way as to provide a flat running surface and remove obstacles and harmful potholes.

C - MODIFYING THE MACHINE

- For your safety and that of others, you must not change the structure and settings of the various components of your machine (hydraulic pressure, calibrating limiters, engine speed, addition of extra equipment, addition of counterweight, unapproved attachments, alarm systems, etc.) yourself. In this case, the manufacturer cannot be held responsible.

D - FRENCH ROAD TRAFFIC RULES

(or see current legislation in other countries)

- Only one EC declaration of conformity is issued. It must be kept in a safe place.
- The road traffic rules for the machines are subject to the provisions of the highway code, according to the following categories:
 - Construction machinery (MT range): public works vehicle not predominantly for use on roads (point 6.9 of Article R.311-1 of the French Highway Code). The machine must have a 25 disc displayed on the rear of the machine and an operating license plate.
 - Non-type-approved "Tractor" machinery for agricultural work: (point 6.2 of Article R.311-1 of the French Highway Code). The machine must be fitted with an operating license plate.
 - Type-approved "Tractor" machinery for agricultural work: Agricultural tractor type T1a (point 5.1.1 of Article R.311-1 of the French Highway Code). The machine must be licensed.

SPECIAL INSTRUCTIONS APPLICABLE TO TYPE-APPROVED "TRACTOR" MACHINES

- All approved machines are supplied with a "Tractor" certificate of compliance with Regulation 167/2013, to be retained by the owner, and a page of administrative details together with a CNIT number (national type approval code) for registration at the prefecture.
- The owner of the machine is responsible for carrying out the necessary procedures for obtaining the vehicle registration document within the time limit defined by the regulations.
- The operator must hold a category B driver's license, unless granted an exemption.
- The machine must be driven on the public highway in accordance with the instructions given in the manual supplied with the machine (Gross weight, Gross combination weight, towing load, axle loads, maximum speeds, etc. according to the type/version). The operator must be in possession of the machine's registration document.

⚠ IMPORTANT ⚠

*When towing a trailer or agricultural equipment, the traveling speed of the machine is limited to 25 km/h.
In this case, a "25" disc must be affixed to the rear of the convoy.*

E - MACHINE CAB PROTECTION

- All machines comply with standard ISO 3471 Roll-over Protective Structures (ROPS)
- All machines comply with standard ISO 3449 Falling-Object Protective Structures (FOPS) (Level I or II) (↔ 2 - DESCRIPTION OF STICKERS AND PLATES)
- The windows used on our machines comply with standard ECE-R43 Operator Protective Structures (OPS).
- Approved "TRACTOR" machines also comply with the regulations:
 - (appendix 1322/2014-OCDE Code 4).
 - (appendix 1322/2014-OCDE Code 10).

⚠ IMPORTANT ⚠

*Structural damage or overturning, a modification, changes or a poorly executed repair can reduce the protective efficiency of the cab, canceling its compliance.
Do not perform welding or drilling on the cab structure.
Consult your dealer to determine the limits of this structure without canceling its compliance.*

INSTRUCTIONS

- The operator's manual must always be in good condition and kept in the place provided in the machine and in the language used by the operator.
- The operator's manual and any plates or stickers which are no longer legible or are damaged, must be replaced immediately.

MAINTENANCE

- Maintenance or repairs other than those detailed in Part: 3 - MAINTENANCE must be carried out by qualified personnel (consult your dealer) and in the necessary safety conditions to preserve the health of the operator and any third party.

⚠ IMPORTANT ⚠

Your machine must be periodically inspected to ensure its continued compliance.

The frequency of this inspection is defined by the current legislation in force in the country in which the machine is used.

- Example for France "The manager in charge of the establishment using a machine must open and maintain a maintenance log for each machine (order of March 2, 2004) and undergo a general periodic inspection every 6 months (order of March 1, 2004)".

INSTRUCTIONS FOR THE OPERATOR

FOREWORD

⚠ IMPORTANT ⚠

The risk of accident while using, servicing or repairing your machine can be reduced if you follow the safety instructions and preventive measures detailed in this manual. Failure to respect the safety and operating instructions, or the instructions for repairing or servicing your machine may lead to serious, even fatal accidents.

- Only the operations and maneuvers described in these operator's manual must be performed. The manufacturer cannot predict all possible risky situations. Consequently, the safety instructions given in the operator's manual and on the machine itself are not exhaustive.
- At all times, as an operator, you must envisage, within reason, the possible risk to yourself, to others or to the machine when you use it.
- The operator is responsible for the machine in all circumstances, regardless of whether he is present in the driver's cab.

⚠ IMPORTANT ⚠

In order to reduce or prevent any danger with a MANITOU-approved attachment, follow the instructions in paragraph: 4 - ADAPTABLE ATTACHMENTS AVAILABLE ON THE RANGE: INTRODUCTION.

GENERAL INSTRUCTIONS

A – OPERATOR'S MANUAL

- Read the operator's manual carefully.
- The operator's manual must always be in good condition and in the place provided for it on the machine.
- You must report any plates and stickers which are no longer legible or which are damaged.

B - AUTHORIZATION FOR USE IN FRANCE

(or see current legislation in other countries).

- Only qualified, authorized personnel can use the machine. This authorization is given in writing by the appropriate person in the establishment where the machine is to be used and must be carried permanently by the operator.
- The operator is not empowered to authorize the driving of the machine by another person.

C - MAINTENANCE

- If the operator sees that the machine is not in good working order or does not comply with the safety instructions, he must inform his manager of this immediately.
- The operator is prohibited from carrying out any repairs or adjustments himself, unless he has been trained for this purpose. He must keep the machine properly cleaned if this is his responsibility.
- The operator is responsible for carrying out daily maintenance (↩ 3 - MAINTENANCE).
- The operator is responsible for deciding and adjusting the frequency and type of the cleaning needed to prevent the risk of fire ensuing from the build-up of flammable material(s). The operator should pay special attention to all the areas of the machine where these high-risk materials are likely to accumulate (e.g. engine compartment, under the boom, above the axles, etc.).

D - TIRES

- The operator must ensure tires are suitable for the nature of the ground (see contact surface with the ground for the tires in the chapter: 2 - DESCRIPTION: TIRES). Optional solutions are available, please consult your dealer.
 - SAND tires.
 - FARM tires.
 - Snow chains.
- The machine's four tires must be the same brand, the same dimensions, the same structure (radial or diagonal) and the same usage category (normal, snow or special), and must have the same degree of tread wear.
- In the event of tire replacement, use tires authorized by MANITOU that are the same type and dimensions. Using different tires voids the machine's type approval and you may be liable.
- If you are replacing just one of the machine's tires (e.g. because it is damaged), we recommend choosing a tire with the same degree of wear as the remaining tires so as not to damage the transmission's kinematic chain.

⚠ IMPORTANT ⚠

Do not use the machine if the tires are damaged or excessively worn, because this could put your own safety or that of others at risk, or cause damage to the machine itself. The fitting of foam inflated tires is prohibited and is not guaranteed by the manufacturer unless with prior authorization.

E - MODIFYING THE MACHINE

- For your safety and that of others, you must not change the structure and settings of the various components of the machine (hydraulic pressure, calibrating limiters, engine speed, addition of extra equipment, addition of counterweight, unapproved attachments, alarm systems, etc.) yourself. In this event, the manufacturer cannot be held responsible.

F - LIFTING PEOPLE

- The use of working equipment and load lifting attachments to lift people is:
 - either forbidden
 - or authorized exceptionally and under certain conditions (↔ regulations in force in the country in which the machine is used).
- The pictogram posted at the operator station reminds you that:
 - Left-hand column
 - It is forbidden to lift people, with any kind of attachment, using a non PLATFORM-fitted machine.
 - Right-hand column
 - With a PLATFORM-fitted machine, people can only be lifted using platforms designed by MANITOU for this purpose.
- MANITOU sells equipment specifically designed for lifting people (OPTION PLATFORM-fitted machine; contact your dealer).

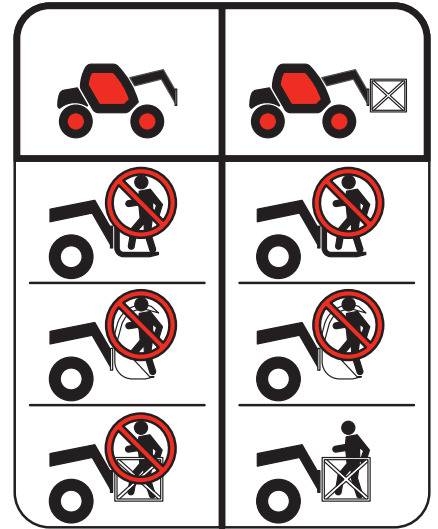

A - BEFORE STARTING UP THE MACHINE

- Perform the daily maintenance operations (< 3 - MAINTENANCE).
- Make sure that the driver's cab is clean, particularly the floor and floor mat. Check that no movable object may hinder the operation of the machine.
- Make sure the lights, turn signals and windshield wipers are working properly.
- Make sure the rear-view mirrors are in good condition, clean and properly adjusted.
- Make sure the horn works.

B - AVAILABLE IN THE DRIVER'S CAB

- Whatever his experience, the operator is advised to familiarize himself with the position and operation of all the controls and instruments before operating the machine.
- Wear clothes suitable for driving the machine, avoid loose clothing.
- Make sure you have the appropriate protective equipment for the task to be performed.
- Prolonged exposure to high noise levels may cause hearing problems. It is recommended to wear ear muffs to protect against excessive noise.
- Always face the driver's cab access when getting in and out of the lift truck and use the handle(s) provided for this purpose. Do not jump out of the machine.
- Remain alert at all times when using the machine. Do not listen to the radio or music using headphones or earphones.
- Never operate the lift truck when hands or feet are wet or soiled with greasy substances.
- For increased comfort, adjust the seat to your requirements and adopt the correct position in the driver's cab.



Under no circumstances must the seat be adjusted while the machine is moving.

- The operator must always be in his normal position in the driver's cab: Arms and legs, and generally any part of the body, should be kept inside the driver's cab of the machine.
- The safety belt must be worn and adjusted to the operator's size.
- The control units must never be used for any other than their intended purposes (e.g. Climbing onto or down from the machine, coat hanger, etc.).
- If the control components are fitted with a forced operation (lever lock) device, it is forbidden to leave the cab without first putting these controls in neutral.
- It is prohibited to carry passengers either on the machine or in the cab.

C - ENVIRONMENT

- Comply with site safety regulations.
- If you have to use the machine in a dark area or work at night, make sure it is equipped with work lights.
- During handling operations, make sure that no one is in the way of the machine and its load.
- Do not allow anybody to come near the working area of the machine or pass beneath an elevated load.
- The maximum slope on which the machine can be used in relation to the capacity of the service brake is 20%.
- When using the lift truck on a transverse slope, before lifting the boom observe the instructions given in the paragraph: INSTRUCTIONS FOR HANDLING A LOAD: D - TRANSVERSE ATTITUDE OF THE MACHINE.
- Traveling on a longitudinal slope:
 - Drive and brake gently.

- Moving without load: Forks or attachment facing downhill.

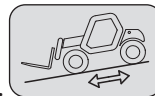

- Moving with load: Forks or attachment facing uphill.

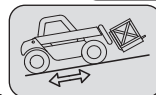

- Take into account the machine's dimensions and its load before trying to negotiate a narrow or low passageway.
- Never move onto a load bridge without having first checked:
 - That it is suitably positioned and made fast.
 - That the unit to which it is connected (wagon, truck, etc.) will not shift.
 - That this bridge is prescribed for the total weight of the machine, laden or unladen.
 - That this bridge is prescribed for the size of the machine.
- Never move onto a foot bridge, floor or freight lift, without being certain that they are suitable for the weight and size of the machine, laden or otherwise, and without having checked that they are in sound working order.
- Be careful in the area of loading bays, trenches, scaffolding, soft ground and manholes.

- Make sure the ground is stable and firm under the wheels and/or stabilizers before lifting or removing the load. If necessary, add sufficient wedging under the stabilisers.
- Make sure that the scaffolding, loading platform, pilings or ground is capable of bearing the load.
- Never stack loads on uneven ground, they may tip over.

⚠ IMPORTANT ⚠

If the load or the attachment must remain above a structure for a prolonged period of time, there is the risk that it will bear on the structure as the jib descends due to cooling of the oil in the cylinders.

To eliminate this risk:

- *Regularly check the distance between the load or the attachment and the structure and readjust this if necessary.*
- *If possible use the machine at an oil temperature as close as possible to ambient temperature.*

- In the case of work near to overhead lines, ensure that the safety distance is sufficient between the machine's working area and the overhead line.

⚠ IMPORTANT ⚠

Do not use this machine during thunderstorms, snowstorms, periods of frost, or in hazardous weather conditions.

⚠ IMPORTANT ⚠

You must consult your local electrical agency.

You could be electrocuted or seriously injured if you operate or park the machine too close to power cables.

In the event of high winds, do not carry out handling work that jeopardizes the stability of the machine and its load, particularly if the load catches the wind badly.

- Prevent the fire risk associated with use in dusty and flammable conditions (e.g. straw, flour, sawdust, organic waste, etc.).

D - VISIBILITY

- The safety of people within the machine's working area, as well as that of the machine itself and the operator, are dependent on good operator visibility of the machine's immediate surroundings in all situations and at all times.
- This machine has been designed to allow good operator visibility (direct or indirect by means of rear-view mirrors) of the immediate surroundings of the machine while driving with no load and with the boom in the transport position.
- Special precautions must be taken if the size of the load restricts visibility towards the front:
 - moving in reverse,
 - site layout,
 - assisted by a person directing the operation (while standing outside the machine's area of travel), making sure to keep this person clearly in view at all times,
 - in any case, avoid reversing over long distances.
- Certain special accessories may require the machine to travel with the boom in the raised position. In such cases, visibility on the right hand side is restricted, and special precautions must be taken:
 - site layout,
 - assisted by a person directing the operation (while standing outside the machine's area of travel).
 - replacement of a suspended load by a load on a pallet.
- If visibility of your road is inadequate, ask someone to assist by directing the operation (while standing outside the machine's area of travel), making sure to keep this person clearly in view at all times.
- Keep all components affecting visibility in a clean, properly adjusted state and in good working order (e.g. windshields, windows, windshield wipers, windshield washers, driving lights and worklights, rear-view mirrors).

E - STARTING THE MACHINE

SAFETY INSTRUCTIONS

⚠ IMPORTANT ⚠

The machine must only be started up or maneuvered when the operator is sitting in the driver's cab with seat belt fastened and adjusted.

- Never try to start the machine by pushing or towing it. Such an operation may cause severe damage to the transmission. If necessary, towing requires the transmission to be put in neutral (< 3 - MAINTENANCE).
- If using an emergency battery for start-up, use a battery with the same characteristics and respect battery polarity when connecting it. Connect at first the positive terminals before the negative terminals.

⚠ IMPORTANT ⚠

*Failure to respect polarity between batteries can cause serious damage to the electrical circuit.
The electrolyte in the battery may produce an explosive gas. Avoid flames and generation of sparks close to the batteries.
Never disconnect a battery while it is being charged.*

INSTRUCTIONS

- Check the closing and locking of the hood(s).
- Check that the cab door is closed.
- Firmly press the brake pedal and hold in position and hold it down.
- Turn the ignition key to position (I) to switch on the machine and the engine preheat system.
- Check that the forward/reverse selector is in neutral, and that the manual parking brake is on.
- Check the fuel level on the dashboard gauge.
- Check the DEF (diesel exhaust fluid) level on the dashboard gauge. (depending on machine model)
- Turn the ignition key to position (III) for no longer than 15 seconds. The engine should then start. Release the ignition key and let the engine run at idling speed.
- Preheat the engine between each start attempt.
- Make sure all the signal lights on the control instrument panel are off.
- Do not use a machine that is non-compliant.
- Check all control instruments when the engine is warm and at regular intervals during use, so as to quickly detect any faults and to be able to correct them without any delay.
- If an instrument does not show the correct display, stop the engine and immediately carry out the necessary operations.

F - OPERATING THE MACHINE

SAFETY INSTRUCTIONS

⚠ IMPORTANT ⚠

We would like to draw the operators' attention to the risks involved in using the machine, in particular:

- Risk of losing control.

- Risk of loss of lateral and frontal stability of the machine.

The operator must remain in control of the machine.

In the event of the machine overturning, do not try to leave the cab during the incident.

YOUR BEST PROTECTION IS TO STAY FASTENED IN THE CAB.

- Observe the company's traffic regulations or, by default, the public highway code.
- Do not carry out operations which exceed the capacities of your machine or attachment.
- Always drive the machine with the forks or attachment in the transport position, i.e., 300 mm (11.81 in) from the ground, the boom retracted and the forks carriage sloping backwards.
- Only carry loads which are balanced and properly anchored to avoid any risk of a load falling off.
- Ensure that pallets, cases, etc. are in good order and suitable for the load to be lifted.
- Familiarize yourself with the machine on the terrain where it will be used.
- Ensure that the service brakes are working properly.
- The loaded machine must not travel at speeds in excess of 12 km/h (7.46 mph).
- Drive smoothly at an appropriate speed for the operating conditions (land configuration, load on the machine).
- Do not use the hydraulic boom controls when the machine is moving.
- Never change the steering mode whilst driving.
- Ensure that visibility is adequate.
- Do not maneuver the machine with the boom in the raised position unless under exceptional circumstances and then with extreme caution, at very low speed and using gentle braking.
- Take bends slowly.

- In all circumstances make sure you are in control of your speed.
- On damp, slippery or uneven terrain, drive slowly.
- Brake gently, never abruptly.
- Only use the machine's forward/reverse selector from a stationary position and never do so abruptly.
- Do not drive with your foot on the brake pedal.
- Always remember that hydrostatic type steering is extremely sensitive to movement of the steering wheel, so turn it gently and not jerkily.
- Never leave the engine on when the lift truck is unattended.
- Do not leave the cab when the machine has a raised load.
- Look where you are going and always make sure you have good visibility along the route.
- Use the rear-view mirrors frequently.
- Drive round obstacles.
- Never drive on the edge of a ditch or steep slope.
- It is dangerous to use two machines simultaneously to handle heavy or bulky loads, since this operation requires particular precautions to be taken. It must only be used exceptionally and after risk analysis.
- The ignition switch has an emergency stop mechanism in case of an operating anomaly occurring in the case of machines not fitted with a punch-operated cut-out.

INSTRUCTIONS

- Always drive the machine with the forks or attachment in the transport position, i.e., 300 mm (11.81 in) from the ground, the boom retracted and the forks carriage sloping backwards.
- For machines with gearboxes, use the recommended gear (↩ 2 - DESCRIPTION: INSTRUMENTS AND CONTROLS).
- Select the steering mode appropriate for the use and/or working conditions (↩ 2 - DESCRIPTION: INSTRUMENTS AND CONTROLS) (depending on machine model).
- Deactivate the parking brake.
- Shift the forward/reverse selector to the selected direction of travel and accelerate gradually until the machine moves off.

⚠ IMPORTANT ⚠

Starting and moving the machine on a slope may be a real hazard.

If the machine is parked or stopped, adhere scrupulously to the following instructions for moving it:

- Press the service brake pedal.
- Release the parking brake.

- Engage the appropriate gear. (depending on machine model)

- Select forward or reverse direction.

- Ensure that there is no one or anything impeding the movement of the machine.

- Release the service brake pedal and accelerate the engine.

The use of the machine loaded or with a trailer increases the risk. In this case, remain extremely vigilant.

Each braking system operates independently.

In the event of an emergency, use the service brake and/or manual parking brake to immobilize the machine.

With the engine off, release the manual parking brake only after restarting the engine and making sure that the service brake is functional.

G - STOPPING THE MACHINE

SAFETY INSTRUCTIONS

- Never leave the ignition key in the machine during the operator's absence.
- When the machine is stationary, or if the operator has to leave his cab (even for a moment), place the forks or attachment on the ground, apply the parking brake and place the forward/reverse selector in neutral.
- Make sure that the machine is not stopped in any position that will interfere with the traffic flow and at less than one meter from the track of a railway.
- In the event of prolonged parking on a site, protect the machine from bad weather, particularly from frost (check the level of antifreeze), and close and lock all the machine accesses (doors, windows, cowls, etc.).

INSTRUCTIONS

- Park the machine on flat ground or on an incline of less than 15%.
- Set the forward/reverse selector to neutral.
- Activate the parking brake.
- Fully retract the jib.
- Lower the forks or attachment to rest on the ground.
- When using an attachment with a grab or jaws, or a bucket with hydraulic opening, close the attachment fully.
- Before stopping the machine after intensive work, leave the engine idling for a few moments to allow the coolant and oil to lower the temperature of the engine and transmission. Do not forget this precaution, in the event of frequent stops or warm stalling of the engine, or else the temperature of certain parts will rise significantly due to the stopping of the cooling system, with the risk of badly damaging such parts.
- Stop the engine with the ignition switch and remove the key.
- Lock all the openings to the machine (doors, windows, cowls, etc.).
- Turn the battery cut-off to the "OFF" position in accordance with the recommendations (◀ 2 - DESCRIPTION)

H - DRIVING THE MACHINE ON THE PUBLIC HIGHWAY

(or see current legislation in other countries)

FRENCH ROAD TRAFFIC RULES

- The driving of non-type-approved "Tractor" machines on the public highway is subject to the provisions of the French Highway Code relating to special machines, defined in Article R.311-1 of the French Highway Code, in category B of the Equipment Order of November 20, 1969, which determines the procedures applicable to special machines. The machine must be fitted with an operating license plate.
- The driving of type-approved "Tractor" machines on the public highway is subject to the provisions of the French Highway Code relating to agricultural tractors, defined in Article R.311-1 of the French Highway Code. The machine must be licensed.
- The machine must be driven on the public highway in accordance with the instructions given in the manual supplied with the machine (Gross weight, Gross combination weight, towing load, axle loads, maximum speeds, etc. according to the type/version). The operator must be in possession of the machine's registration document.
- The operator must hold an HGV license, unless granted an exemption.
- When towing a trailer or agricultural equipment, the travel speed of the machine is limited to 25 km/h. In this case, a "25" disc must be affixed to the rear of the convoy.

SAFETY INSTRUCTIONS

- Operators driving on the public highway must comply with current highway code legislation.
- The machine must comply with current road legislation. If necessary, there are optional solutions. Contact your dealer.

INSTRUCTIONS

- Make sure the revolving light is in place, switch it on and verify its operation.
- Make sure the lights, turn signals and windshield wipers are working properly.
- Check the cleanliness of the machine's mudguards.
- Check the general cleanliness of the machine before driving on public roads.
- Switch off the worklights if the machine is fitted with them.
- Select the steering mode "HIGHWAY TRAFFIC" (↩ 2 - DESCRIPTION: INSTRUMENTS AND CONTROLS) (depending on machine model).
- Fully retract the jib and set the attachment approximately 300 mm (11.81 in) off the ground.
- Put the frame leveling in the central position, i.e., the transverse axis of the axles parallel to the frame (depending on the machine model).
- Fully raise the stabilizers and turn the shoes inwards (depending on the machine model).

⚠ IMPORTANT ⚠

Never coast in neutral (forward/reverse selector or gear lever in neutral or transmission cut-off button pressed) to preserve the machine's engine brake. Failure to observe this instruction on a slope will lead to excessive speed, which may make the machine uncontrollable (steering, brakes) and cause serious mechanical damage.

DRIVING THE MACHINE WITH A FRONT-MOUNTED ATTACHMENT

- You must comply with current regulations in your country, covering the possibility of driving on the public highway with a front-mounted attachment on your machine.
- If road legislation in your country authorizes circulation with a front-mounted attachment, you must at least:
 - Protect and report any sharp and/or dangerous edges on the attachment (↩ 4 - ADAPTABLE ATTACHMENTS AVAILABLE ON THE RANGE).
 - The attachment must not be loaded.
 - Make sure that the attachment does not mask the lighting range of the forward lights.
 - Make sure that current legislation in your country does not require other obligations.

OPERATING THE MACHINE WITH A TRAILER

- For using a trailer, observe the regulations in force in your country (maximum travel speed, braking, maximum weight of trailer, etc.).
- Do not forget to connect the trailer's electrical equipment to that of the machine.
- The trailer's braking system must comply with current legislation.
- If pulling a trailer with assisted braking, the tractor machine must be equipped with a trailer braking mechanism. In this case, do not forget to connect the trailer braking equipment to that of the machine.
- The vertical force on the towing hook must not exceed the maximum authorized by the manufacturer (consult the manufacturer's plate on your machine).
- The authorized gross vehicle weight must not exceed the maximum weight authorized by the manufacturer (↩ 2 - DESCRIPTION: SPECIFICATIONS).

IF NECESSARY, CONSULT YOUR DEALER.

INSTRUCTIONS FOR HANDLING A LOAD

A - CHOICE OF ATTACHMENTS

- Only attachments approved and authorized by MANITOU can be used on its machines.
- Make sure the attachment is suitable for the work to be done (◀ 4 - ADAPTABLE ATTACHMENTS AS OPTIONS ON THE RANGE).
- If the machine is equipped with the single sideshift attachment OPTION (TSDL), use only the authorized attachments (◀ 4 - ADAPTABLE ATTACHMENTS AS OPTIONS ON THE RANGE).
- Make sure the attachment is correctly installed and locked onto the machine carriage.
- Make sure that your machine attachments are working properly.
- Comply with the load chart limits for the machine for the attachment used.
- Do not exceed the rated capacity of the attachment.
- Never lift a slung load without the attachment provided for the purpose, as there is a risk of the sling slipping (◀ INSTRUCTIONS FOR HANDLING A LOAD: H - PICKING UP AND PUTTING DOWN A SUSPENDED LOAD).
- Do not handle loads suspended by straps directly on the forks (e.g. big bags), as there is a risk of shearing on sharp edges. Use an attachment designed for this purpose.

B - WEIGHT OF LOAD AND CENTER OF GRAVITY

- Before picking up a load, you must know its weight and its center of gravity.
- The longitudinal position of the center of gravity in relation to the heel of the forks (Fig. B1) is defined on the load chart for your machine (◀ 2 - DESCRIPTION: DIMENSIONS AND LOAD CHARTS). For loads with center of gravity exceeding this distance, contact your dealer.
- For irregular loads, determine the transverse center of gravity before any handling (fig. B2) and set it in the longitudinal axis of the machine.

⚠ IMPORTANT ⚠

*It is forbidden to handle a load heavier than the effective capacity defined on the machine load chart.
For loads with a moving center of gravity (e.g. liquids), take account of the variations in the center of gravity in order to determine the load to be handled and be extra vigilant and careful to limit these variations as far as possible.*

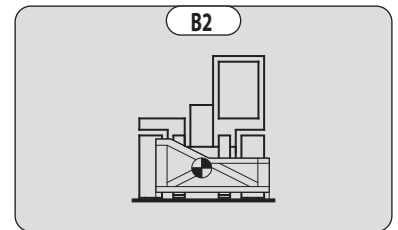
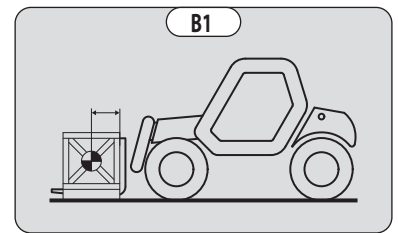

C - LONGITUDINAL STABILITY INDICATOR

⚠ IMPORTANT ⚠

Always watch this device during handling operations.

- Letters and angle indicator (fig. C1) allow to read and respect load capacities of the lifttruck according to the load chart (◀ 2 - DESCRIPTION: LOAD CHART).
- When the device is in limit stability, it is forbidden to perform so-called «AGGRAVATING» movements, these being:
 - Extending the boom.
 - Lowering the boom.
- Perform movements to relieve aggravation in the following order (fig. C2): if necessary, raise the boom (1), retract the boom as far as possible (2) and lower the boom (3) to release the load.

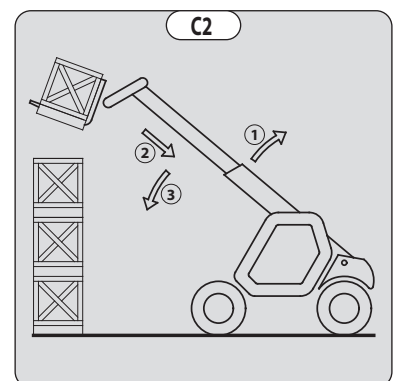
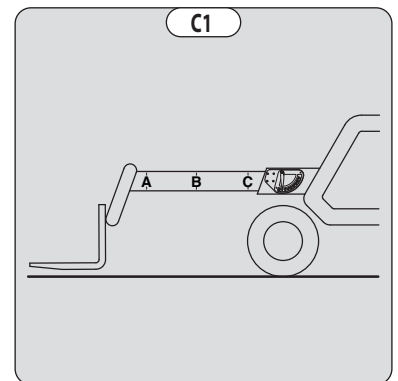

D - TRANSVERSE ATTITUDE OF THE MACHINE

Depending on machine model

The transverse attitude is the transverse slope of the frame with respect to the horizontal. Raising the boom reduces the machine's lateral stability. The machine's transverse attitude must be set with the boom in the down position as follows:

1 - MACHINE WITHOUT FRAME LEVELING USED ON TIRES

- Position the machine so that the bubble in the level is between the two lines (↖ 2 - DESCRIPTION: INSTRUMENTS AND CONTROLS).

2 - MACHINE WITH FRAME LEVELING USED ON TIRES

- Correct the tilt using the hydraulic control and check the horizontality with the spirit level. The bubble of the level must be between the two lines (↖ 2 - DESCRIPTION: INSTRUMENTS AND CONTROLS).

3 - MACHINE USED ON STABILIZERS

- Set the two stabilizers on the ground and raise the two front wheels of the machine (fig. D1).
- Correct the tilt using the stabilizers (Fig. D2) and check the horizontality with the spirit level. The bubble of the level must be between the two lines (↖ 2 - DESCRIPTION: INSTRUMENTS AND CONTROLS). In this position, the two front wheels must be off the ground.

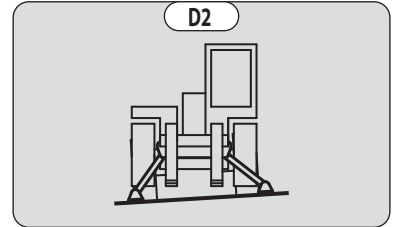
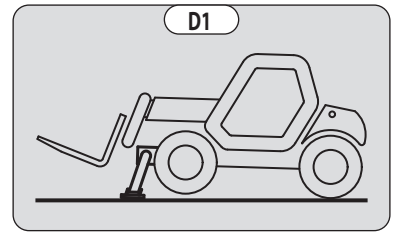

E - PICKING UP A LOAD ON THE GROUND

- Approach the machine perpendicular to the load, with the boom retracted and the forks in a horizontal position (fig. E1).
- Adjust the fork spacing and centering relative to the load to ensure stability (Fig. E2) (optional solutions exist, consult your dealer).
- Never lift a load with a single fork.

⚠ IMPORTANT ⚠

Beware of the risks of trapping or squashing limbs when manually adjusting the forks.

- Move the machine forward slowly (1) and bring the forks up to the stop in front of the load (Fig. E3). If necessary, slightly lift the boom (2) while picking up the load.
- Bring the load into the transport position.
- Tilt the load far enough backward to ensure stability (loss of load on braking or going downhill).

FOR A NON-PALLETIZED LOAD

- Tilt the carriage (1) forwards and move the machine slowly forwards (2), to insert the fork under the load (Fig. E4) (chock the load if necessary).
- Continue to move the machine (2) forward, tilting the carriage (3) (fig. E4) backward to position the load on the forks and check the load's longitudinal and lateral stability.

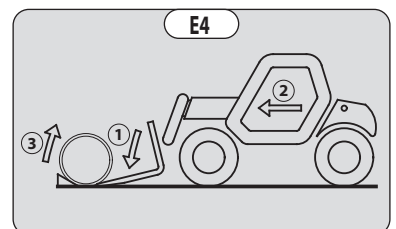
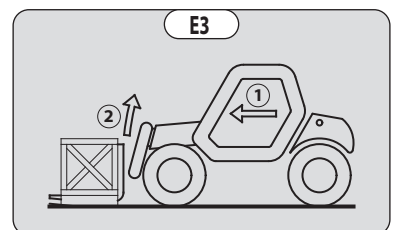
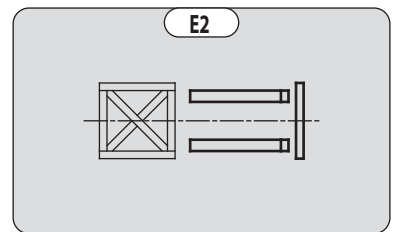
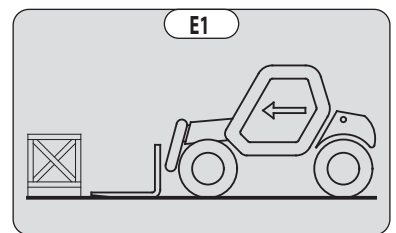

F - PICKING UP AND PUTTING DOWN A HIGH LOAD ON TIRES

⚠ IMPORTANT ⚠

You must not raise the boom if you have not checked the transverse attitude of the machine (← INSTRUCTIONS FOR HANDLING A LOAD D - TRANSVERSE ATTITUDE OF THE MACHINE).

REMINDER: Make sure that the following operations can be performed with good visibility (← OPERATING INSTRUCTIONS UNLADEN AND LADEN: D - VISIBILITY).

PICKING UP A HIGH LOAD ON TIRES

- Ensure that the forks will easily pass under the load.
- Raise and extend the boom (1) (2) until the forks are at the level of the load. If necessary, move the machine (3) forward (fig. F1), driving very slowly and carefully.
- Always remember to keep the distance necessary for inserting the forks under the load, between the stack and the machine (fig. F1) and use the shortest possible length of boom.
- Insert the forks under the load as far as they will go by alternately extending and lowering the boom (1) or, if necessary, moving the machine forward (2) (fig. F2). Activate the parking brake and place the forward/reverse selector in neutral.
- Lift the load slightly (1) and tilt the carriage (2) backwards to stabilize the load (Fig. F3).
- Tilt the load sufficiently backward to ensure its stability.
- Monitor the longitudinal stability indicator (← INSTRUCTIONS FOR HANDLING A LOAD: C - LONGITUDINAL STABILITY INDICATOR). If it is overloaded, set the load back down in the place from which it was picked up.
- If possible, lower the load without moving the machine. Raise the boom (1) to release the load, retract (2) and lower the jib (3) to set the load into transport position (fig. F4).
- If this is not possible, reverse the machine (1), maneuvering very gently and carefully to release the load. Retract (2) and lower the boom (3) to bring the load into the transport position (fig. F5).

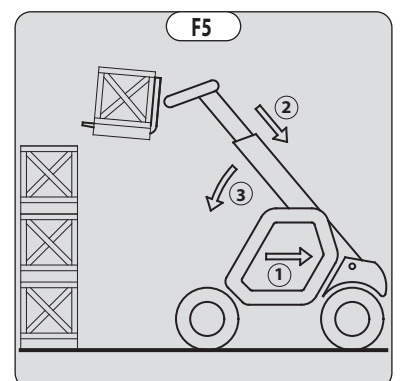
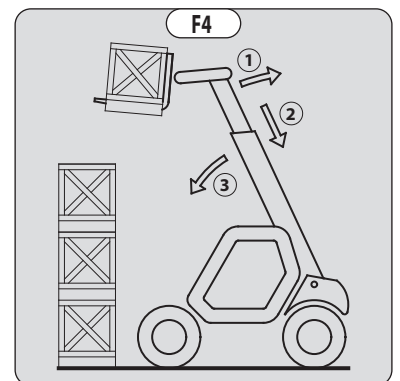
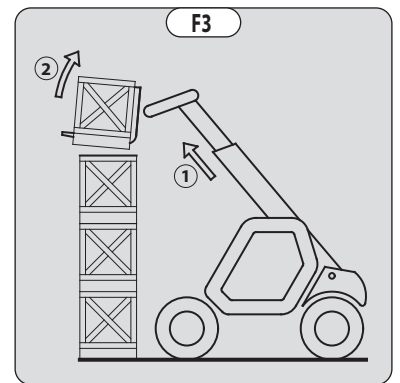
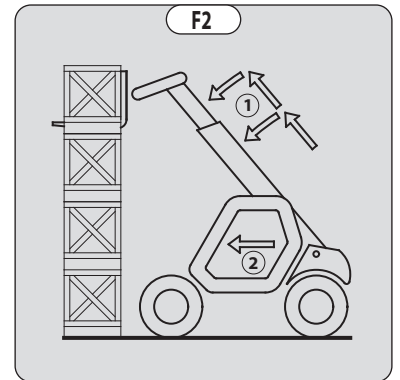
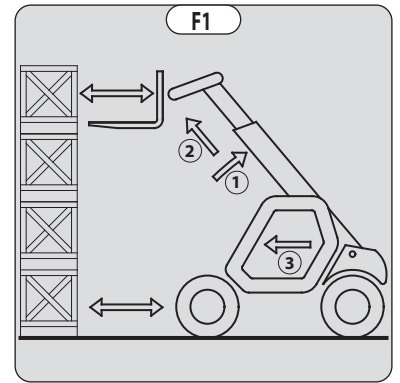

PUTTING DOWN A HIGH LOAD ON TIRES

- Approach the load in the transport position in front of the stack (Fig. F6).
- Activate the parking brake and place the forward/reverse selector in neutral.
- Raise and extend the boom (1) (2) until the load is above the stack, while monitoring the longitudinal stability indicator (◀ INSTRUCTIONS FOR HANDLING A LOAD: C - LONGITUDINAL STABILITY INDICATOR). If necessary, move the lift truck (3) forward (fig. F7), driving very slowly and carefully.
- Place the load in a horizontal position and put it down on the pile by lowering and retracting the boom (1) (2) in order to position the load correctly (Fig. F8).
- If possible, release the forks by alternately retracting and raising the boom (1) (Fig. F9). Then set the forks into transport position.
- If this is not possible, reverse the machine (1), maneuvering very slowly and carefully to release the forks (fig. F10). Then set the forks into transport position.

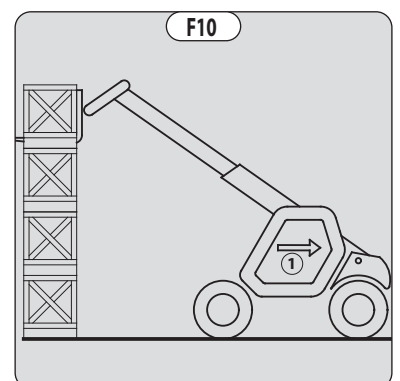
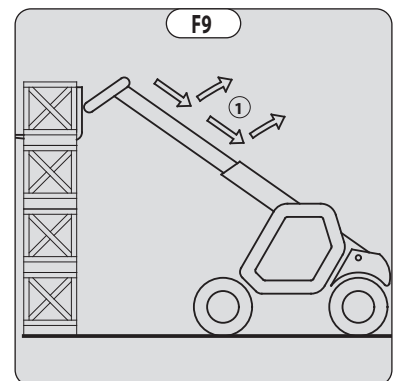
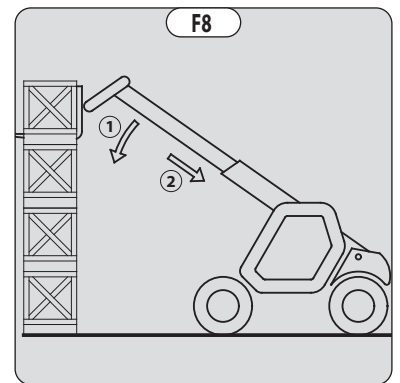
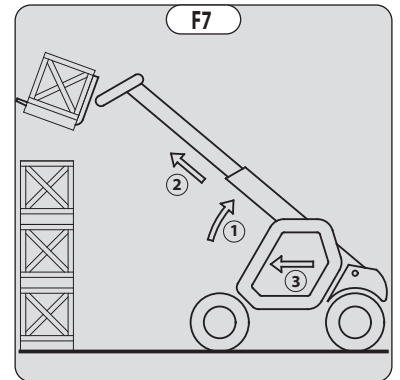
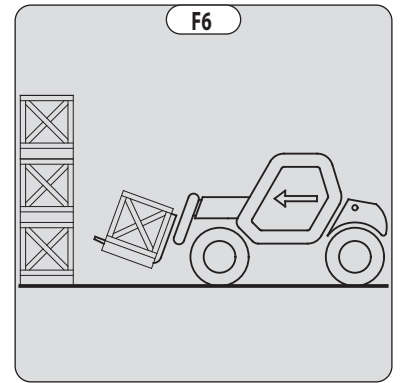

G - PICKING UP AND PUTTING DOWN A HIGH LOAD ON STABILIZERS

Depending on machine model

⚠ IMPORTANT ⚠

You must not raise the boom if you have not checked the transverse attitude of the machine (← INSTRUCTIONS FOR HANDLING A LOAD D - TRANSVERSE ATTITUDE OF THE MACHINE).

REMINDER: Make sure that the following operations can be performed with good visibility (← OPERATING INSTRUCTIONS UNLADEN AND LADEN: D - VISIBILITY).

The stabilizers are used to optimize the machine's lifting performance (← 2 - DESCRIPTION: INSTRUMENTS AND CONTROLS).

POSITIONING THE STABILIZERS WITH THE FORKS IN TRANSPORT POSITION (UNLADEN AND LADEN)

- Set the forks in transport position in front of the elevation.
- Stay far enough away to allow the boom to be raised.
- Activate the parking brake and place the forward/reverse selector in neutral.
- Set the two stabilizers on the ground and lift the two front wheels of the machine (fig. G1), while maintaining its transverse stability.

RAISING THE STABILIZERS WITH THE FORKS IN TRANSPORT POSITION (UNLADEN AND LADEN)

- Raise both stabilizers fully and at the same time.

LOWERING THE STABILIZERS WITH JIB UP (UNLADEN AND LADEN)

⚠ IMPORTANT ⚠

This operation must be exceptional and performed with great care.

- Raise the boom and retract the telescopes completely.
- Set the machine in position in front of the elevation (fig. G2), moving very slowly and carefully.
- Activate the parking brake and place the forward/reverse selector in neutral.
- Move the stabilizers very slowly and gradually as soon as they are close to the ground or in contact with it.
- Lower the two stabilizers and lift the two front wheels of the machine (fig. G3). During this operation, transverse attitude must be permanently maintained: the bubble in the level must be kept between the two lines.

SETTING THE STABILIZERS WITH THE BOOM UP (UNLADEN AND LADEN)

⚠ IMPORTANT ⚠

This operation must be exceptional and performed with great care.

- Keep the boom raised and retract the telescopes completely (Fig. G3).
- Move the stabilizers very slowly and gradually as soon as they are in contact with the ground and when they leave the ground. During this operation, transverse attitude must be permanently maintained: the bubble in the level must be kept between the two lines.
- Raise both stabilizers completely.
- Deactivate the parking brake and reverse the machine (1) very slowly and carefully to release it and lower the forks (2) into transport position (fig. G4).

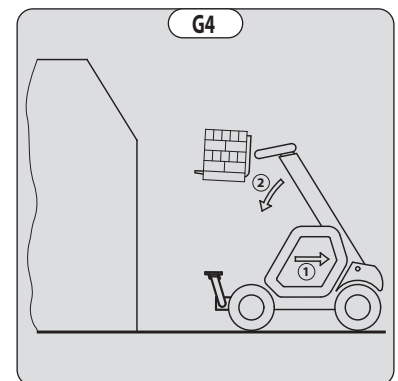
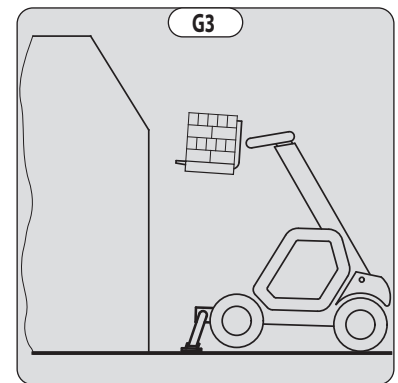
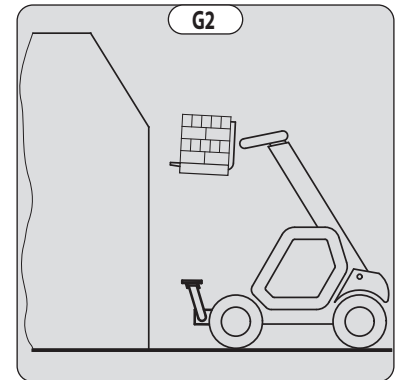
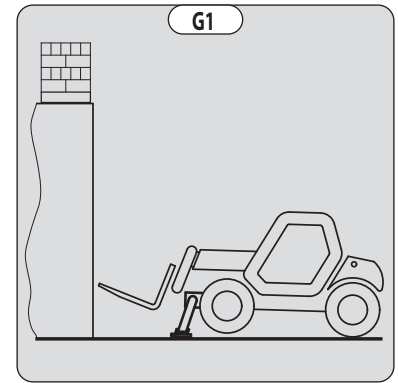

PICKING UP A HIGH LOAD ON STABILIZERS

- Ensure that the forks will easily pass under the load.
- Check the position of the machine with respect to the load and make a test run, if necessary, without picking up the load.
- Raise and extend the boom (1) (2) until the forks are at the level of the load (Fig. G5).
- Bring the forks to the stop in front of the load by alternately extending and lowering the boom (1) (Fig. G6).
- Lift the load slightly (1) and tilt the carriage (2) backwards to stabilize the load (Fig. G7).
- Monitor the longitudinal stability indicator (⚠ INSTRUCTIONS FOR HANDLING A LOAD: C - LONGITUDINAL STABILITY INDICATOR). If it is overloaded, set the load back down in the place from which it was picked up.
- If possible, lower the load without moving the machine. Raise the boom (1) to release the load, retract (2) and lower the jib (3) to set the load into transport position (fig. G8).

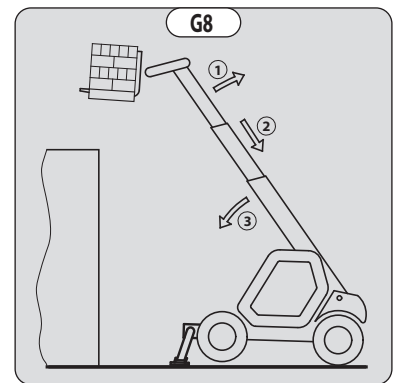
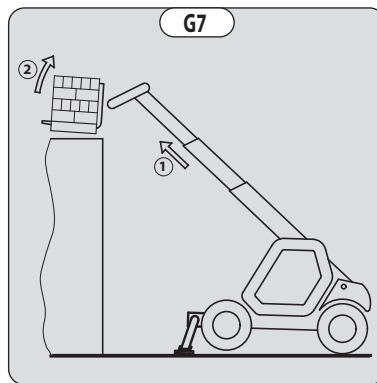
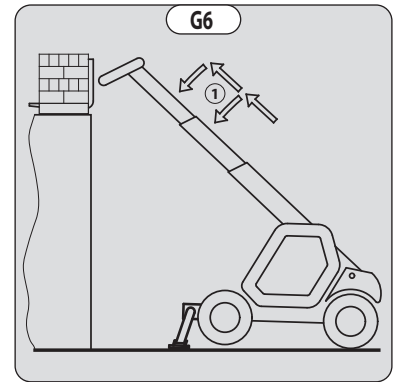
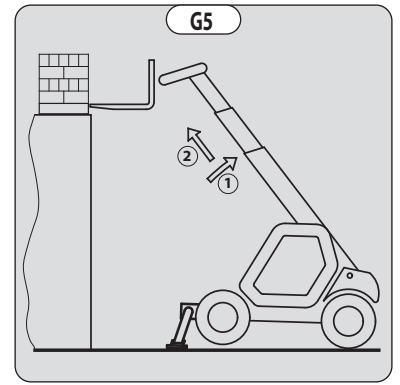

SETTING DOWN A HIGH LOAD ON STABILIZERS

- Raise and extend the boom (1) (2) until the load is above the elevation (fig. G9), while monitoring the longitudinal stability indicator (⚠ INSTRUCTIONS FOR HANDLING A LOAD: C - LONGITUDINAL STABILITY INDICATOR).
- Position the load horizontally and release it by lowering and retracting the boom (1) (2) to position the load correctly (Fig. G10).
- Free the forks by alternately retracting and raising the boom (3) (Fig. G11).
- If possible, set the boom in transport position without moving the machine.

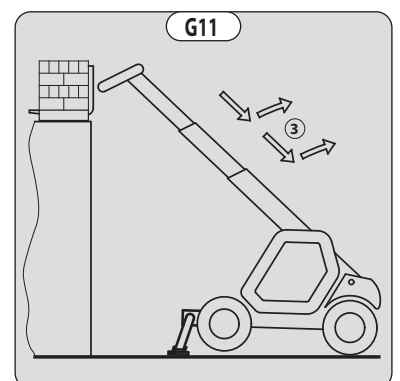
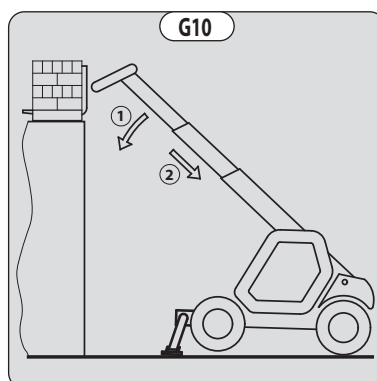
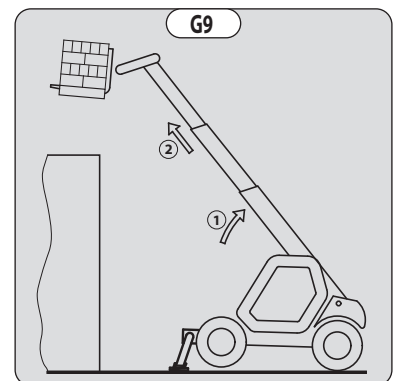

H - PICKING UP AND PUTTING DOWN A SUSPENDED LOAD

⚠ IMPORTANT ⚠

*Failure to follow the above instructions may lead the machine to lose stability and overturn.
MUST be used with a machine equipped with an operational hydraulic movement cut-off device.*

CONDITIONS OF USE

- The length of the sling or the chain shall be as short as possible to limit swinging of the load.
- Lift the load vertically along its axis, never by pulling sideways or lengthways.

HANDLING WITHOUT MOVING THE MACHINE

- Whether on stabilizers or on tires, the lateral attitude must not exceed 1% and the longitudinal attitude must not exceed 5%: the bubble of the level must be held at "0".
- Ensure that the wind speed is not higher than 10 m/s (32,8 fps).
- Ensure that there is no one between the load and the machine.

I - TRAVELING WITH A SUSPENDED LOAD

- Before moving, inspect the terrain in order to avoid excessive slopes and cross-falls, bumps and potholes, or soft ground.
- Ensure that the wind speed is not higher 36 km/h (22.37 mph).
- The machine must not travel at more than 0.4 m/s (1.5 km/h (0.93 mph), i.e. one quarter walking speed).
- Drive and stop the machine gently and smoothly to minimize swinging of the load.
- Carry the load a few centimeters above the ground (max. 30 cm (11.81 in) the shortest possible jib length. Do not exceed the offset indicated on the load chart. If the load begins to swing excessively, do not hesitate to stop and lower the jib to set down the load.
- During transport, the lift truck operator must be assisted by a person on the ground (standing a minimum of 3 m (9-10.11 ft-in) from the load), who will limit swinging of the load using a bar or a rope. Ensure that this person is always clearly in view.
- The lateral attitude must not exceed 5%: the bubble in the level must be kept between the two "MAX" marks.
- The longitudinal attitude must not exceed 15% with the load facing uphill and 10% with the load facing downhill.
- The boom angle must not exceed 45°.

INSTRUCTIONS FOR USE AS A LOADER

For agricultural-type machines (MLT range)

A - LOADING

⚠ IMPORTANT ⚠

You must not raise the boom if you have not checked the transverse attitude of the machine (← INSTRUCTIONS FOR HANDLING A LOAD D - TRANSVERSE ATTITUDE OF THE MACHINE).

REMINDER: Make sure that the following operations can be performed with good visibility (← OPERATING INSTRUCTIONS UNLADEN AND LADEN: D - VISIBILITY).

FILLING THE BUCKET

- Place the bottom of the bucket in a horizontal position, just in contact with the ground (1) (Fig. A1).
- Move forward gradually (2) while simultaneously raising the boom and tilting the bucket backwards (3), for improved filling and breakout (Fig. A1).
- Reverse the machine (1) very carefully and gently to free the bucket. Lower the boom (2) into the transport position (Fig. A2).

⚠ IMPORTANT ⚠

Tilt the bucket sufficiently back to avoid spilling product and ensure its stability (loss of product under braking).

LOADING A TRAILER

- Approach the side of the trailer in the transport position (Fig. A3).
- Raise and extend the boom (1) (2) until the bucket is above the trailer, while monitoring the longitudinal stability indicator (← INSTRUCTIONS FOR HANDLING A LOAD: C - LONGITUDINAL STABILITY INDICATOR) (fig. A4).
- Drive the machine forward (3) very carefully and gently so that the bucket empties its load in the center of the trailer (Fig. A4).
- Immobilize the machine with the service brake pedal and put the reversing shift lever in neutral.

N.B.: Immobilizing the machine with the service brakes means that the transmission should be in neutral. Failure to follow this recommendation may lead to overheating and damage to the brakes.

- Slowly discharge the product (4) (Fig. A4).
- Tilt the bucket backwards (1) and reverse the machine (2) very carefully and gently (Fig. A5).
- Retract (3) and lower the boom (4) into the transport position (Fig. A5).

B - BACKFILLING

- Place the bottom of the bucket in a horizontal position, just in contact with the ground (1) (Fig. B1).
- Drive forward gradually (2). Once filled, the bucket will act as a leveling blade (Fig. B1).

⚠ IMPORTANT ⚠

When driving, beware of trenches as well as recently excavated and/or backfilled ground.

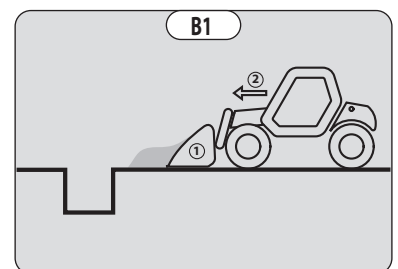
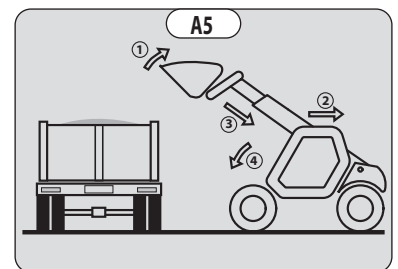
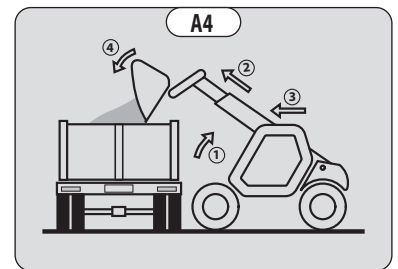
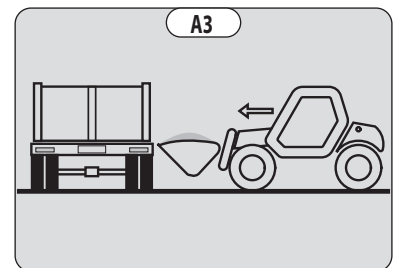
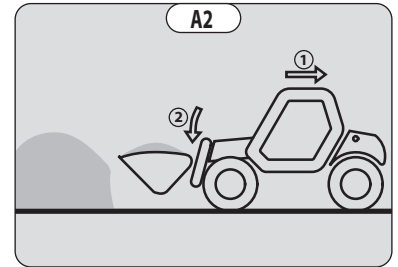
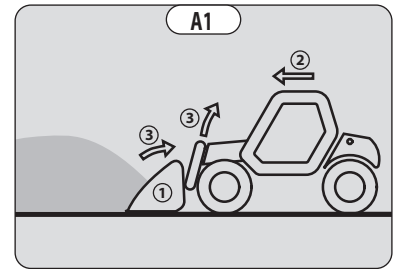

INSTRUCTIONS FOR USING THE MOBILE ELEVATING WORK PLATFORM

For machines equipped with a MOBILE ELEVATING WORK PLATFORM

A - AUTHORIZATION FOR USE

- Operation of the platform requires further authorization in addition to that of the machine.

B - SUITABILITY OF THE PLATFORM FOR THE JOB

- Our machines fitted with mobile elevating work platforms are compliant with standard **EN 280** for Europe and standard **AS/NZS 1418.10:2011** for Australia, corresponding to the classification of Group C1 to C3 in accordance with this standard.
- MANITOU has ensured that this platform is suitable for use under the normal operating conditions provided in this operator's manual, with a STATIC test coefficient of 1.25 and a DYNAMIC test coefficient of 1.1 as specified in harmonized European standard **EN 280** for mobile elevating work platforms.
- Before commissioning, the company manager must make sure that the platform is appropriate for the work to be done, and perform certain tests (in accordance with current legislation).

C - PROVIDED ON THE PLATFORM

- Wear suitable clothing when using the platform, avoid loose-fitting garments.
- Never use the platform with hands or shoes that are wet or soiled with greasy substances.
- Remain alert at all times when using the platform. Do not listen to the radio or music using headphones or earphones.
- MANITOU strongly recommends wearing a safety harness attached to an attachment point in the platform. Wearing a safety harness or other personal protection equipment against falls may be compulsory. Comply with local, government and national regulations in force, employer's safety rules and work site regulations .
- The safety harness or other personal protection equipment against falls must comply with local, government, and national regulations in force. They must be inspected in accordance with the regulations in force.
- The control units must never be used for any other than their intended purposes (e.g. Climbing onto or down from the machine, coat hanger, etc.).
- Safety helmets must be worn.
- The operator must always be in his normal position in the driver's cab: it is prohibited to have arms or legs, or generally any part of the body, outside the platform.
- Ensure that materials loaded onto the platform (pipes, cables, containers, etc.) cannot fall out. Do not pile these materials to the point where it is necessary to step over them.

D - USING THE PLATFORM

- However experienced they may be, operators must acquaint themselves with the emplacement and operation of all control instruments prior to operating the platform.
- Check before use that the platform has been correctly assembled and locked onto the machine.
- Do not enter or exit the platform unless it is fully lowered.
- Always enter and exit the platform through the gate or using the sliding intermediate cross members (depending on the model).
- Always enter and exit facing the interior of the platform.
- Always use both hands and one foot or both feet and one hand to enter and exit the platform.
- Make sure that the sliding intermediate cross members (depending on the model) are in the lower position and that the gate is properly closed (depending on the model) before using this platform.
- Do not attach the sliding mid rails in the high position.
- The platform should be operated in an area free of any obstructions or danger when it is lowered to the ground.
- The operator using the platform must be aided by someone on the ground with adequate training.
- You should stay within the limits set out in the platform load chart.
- The lateral constraints are limited (↩ 2 - DESCRIPTION: SPECIFICATIONS).
- It is strictly forbidden to suspend a load from the platform or the machine's boom without an attachment provided for the purpose (↩ INSTRUCTIONS FOR HANDLING A LOAD: H - PICKING UP AND PUTTING DOWN A SUSPENDED LOAD).
- The platform cannot be used as a crane or a lift for permanently transporting people or materials, nor as jacks or supports.
- The machine must not be moved with one (or more) person(s) on the platform.
- It is forbidden to transport people on the platform using the hydraulic controls in the machine's cab (except in case of rescue).
- The operator must not climb onto to off the platform when it is not on ground level (jib retracted and in the down position).
- The machine must not be fitted with unauthorized attachments that increase the windage of the assembly.
- Do not use ladders or improvised structures on the platform to gain extra height.
- Do not climb onto the rails of the platform to gain extra height.
- It is forbidden to use the platform on forks. The fork slots are only to, be used for storing the platform and not for lifting people under any circumstances.

E - ENVIRONMENT

- Maintain a safe distance between electrical lines or live components and any part of the body, any conductive object or any part of the machine, unless the local, government and national regulations in force, the safety rules of the employer or construction site regulations are more stringent in terms of distance required.
- Allow for platform movement and swaying or sagging power lines.

⚠ IMPORTANT ⚠

It is forbidden to use the platform close to electricity cables. Maintain the specified safe distances.

RATED VOLTAGE	SAFETY DISTANCE (FT-IN/METRES)
50 < U < 1,000	7-6.55/2,30
1,000 < U < 30,000	8-2.42/2,50
30,000 < U < 45,000	8-6.36/2,60
45,000 < U < 63,000	9-2.23/2,80
63,000 < U < 90,000	9-10.11/3,00
90,000 < U < 150,000	11-1.85/3,40
150,000 < U < 225,000	13-1.48/4,00
225,000 < U < 400,000	17-4.66/5,30
400,000 < U < 750,000	25-11.02/7,90

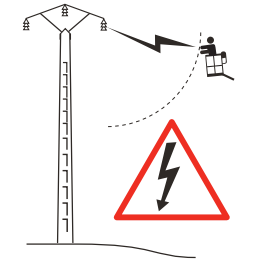

⚠ IMPORTANT ⚠

It is strictly forbidden to use the platform when the wind speed exceeds 45 km/h (27.96 mph).

- To visually recognize this wind speed, refer to the empirical wind evaluation scale below:

BEAUFORT scale (wind speed at a height of 32-9,7 ft-in (10 m) on a flat site)							
Force	Type of wind	Speed (knots)	Speed (mph)	Speed (km/h)	Speed (m/s)	Effects on Land	Sea conditions
0	Calm	0 - 1	0 - 1	0 - 1	<0.3	Smoke rises vertically.	Sea is like a mirror.
1	Light air	1 - 3	1 - 3	1 - 5	0.3 - 1.5	Smoke indicates direction of wind.	Ripples with appearance of scale, no foam crests.
2	Light breeze	4 - 6	4 - 7	6 - 11	1.6 - 3.3	Wind felt on face, leaves rustle.	Short wavelets, but pronounced.
3	Gentle breeze	7 - 10	8 - 12	12 - 19	3.4 - 5.4	Leaves and small twigs in constant motion.	Very small waves, crests begin to break.
4	Moderate breeze	11 - 16	13 - 18	20 - 28	5.5 - 7.9	Wind raises dust and loose pieces of paper; small branches are moved.	Small waves, becoming longer, numerous whitecaps.
5	Fresh breeze	17 - 21	19 - 24	29 - 38	8 - 10.7	Small trees in leaf begin to sway.	Wavelets form on inland waters; moderate waves, taking longer form.
6	Strong breeze	22 - 27	25 - 31	39 - 49	10.8 - 13.8	Large branches in motion, whistling heard in overhead wires, umbrella use becomes difficult.	Larger waves forming, whitecaps everywhere, some spray.
7	Near gale	28 - 33	32 - 38	50 - 61	13.9 - 17.1	Whole trees in motion, inconvenience felt when walking against the wind.	Sea heaps up; white foam from breaking waves begins to be blown in streaks along the direction of the wind.
8	Gale	34 - 40	39 - 46	62 - 74	17.2 - 20.7	Wind breaks twigs off trees; impedes progress.	Moderately high waves of greater length; edges of crests begin to break into spindrift.
9	Strong gale	41 - 47	47 - 54	75 - 88	20.8 - 24.4	Wind damages roofs (chimneys, slates, etc.).	High waves, crests of waves begin to topple, streaks of foam; reduced visibility.
10	Storm	48 - 55	55 - 63	89 - 102	24.5 - 28.4	Seldom experienced inland; trees uprooted; considerable structural damage occurs.	Very high waves; white streaks of foam; reduced visibility.
11	Violent storm	56 - 63	64 - 72	103 - 117	28.5 - 32.6	Very rare, widespread damage.	Exceptionally high waves able to hide medium sized ships from view, reduced visibility.
12	Hurricane	64 +	72 +	118 +	32.7 +	Devastating damage.	Sea completely white; air filled with foam and spray, very reduced visibility.

F - MAINTENANCE

⚠ IMPORTANT ⚠

Your platform must be periodically inspected to ensure its continued compliance. The frequency of this inspection is defined by the legislation in force in the country in which the platform is used. In France, a general periodic inspection every 6 months (Decree of March 1, 2004).

INSTRUCTIONS FOR USING THE RADIO-CONTROL

For machines with RC radio control

HOW TO USE THE RADIO-CONTROL

SAFETY INSTRUCTIONS

⚠ IMPORTANT ⚠

It is prohibited to lift people in the platform using the radio-control.

It is prohibited to use the radio-control from the platform:

- This radio-control consists of electronic and mechanical safety elements. It cannot receive commands from another transmitter because the internal encoding is unique to each radio-control.

⚠ IMPORTANT ⚠

If it is used improperly or incorrectly, there is a risk of danger to:

- The physical and mental health of the user or others.

- The machine and other neighboring items.

Everyone working with this radio-control:

- Must be qualified in line with current regulations and trained accordingly.

- Must follow this instruction manual as closely as possible.

- The system is used to control the machine remotely via radio waves. Commands are also transmitted if the machine is out of sight (behind an obstacle or a building for example), this is why:
 - After stopping the truck and removing the key switch (only possible when it is stationary), always place the transmitter in a safe, dry place.
 - Before performing any installation, servicing or repair work, always switch off power sources (in particular, electric welding devices and electric head units on hydraulic distributors must be disconnected at each section).
 - Never remove or alter the safety devices (such as the hand-guard frame, key, emergency stop button, etc.).

⚠ IMPORTANT ⚠

Never drive the machine if it is not continuously and perfectly within view of the operator.

- Before leaving the transmitter, the operator must make sure that it cannot be used by an unauthorized third person: either by removing the key button from the transmitter or locking it in an inaccessible place.
- The user must ensure that the instruction manual is accessible at all times and that operators have read and understood it.

INSTRUCTIONS

- Take up position in a stable place with no risk of slipping.
- Before using the transmitter, make sure there is nobody within the working area.
- Only use the transmitter with its carrying device or installed correctly on the platform.

⚠ IMPORTANT ⚠

When you remove the transmitter, remove the accumulator and key button so that it cannot be used accidentally or deliberately by anyone else.

PROTECTIVE DEVICES

- The machine will be immobilized within a maximum of 450 milliseconds (approx. 0.5 second):
 - If the emergency stop button of the transmitter is pressed (50 milliseconds), or that of the machine.
 - If the transmission distance of the radio waves is exceeded.
 - If the transmitter is faulty.
 - If an interfering radio signal is received from elsewhere.
 - If the accumulator is removed from its housing in the transmitter.
 - If the battery reaches the end of its autonomy.
 - If the transmitter is switched off by turning the key switch to the off position.
- These protective devices are provided for the safety of personnel and property and must never be modified, removed or bypassed in any way whatsoever!
- The hand-guard frame prevents external action on a joystick (e.g. if the transmitter is dropped, or if the operator leans on a guard-rail).
- An electronic safety device prevents radio transmission from being initiated if the joysticks are not mechanically and electrically at rest and if the internal combustion engine speed selector is not set to idle.

⚠ IMPORTANT ⚠

In an emergency, press the transmitter emergency stop button immediately; then follow the manual's instructions (↩ 2 - DESCRIPTION: INSTRUMENTS AND CONTROLS).

MACHINE MAINTENANCE INSTRUCTIONS

GENERAL INSTRUCTIONS

- Make sure the area is adequately ventilated before starting up the machine.
- Wear clothes suitable for the maintenance of the machine. Avoid wearing jewelry and loose clothes. Tie back and protect your hair, if necessary.
- Stop the engine and remove the ignition key before carrying out any work.
- Read the operator's manual carefully.
- Carry out all repairs immediately, even if the repairs concerned are minor.
- Repair all leaks immediately, even if the leak concerned is minor.
- Ensure that process materials and of spare parts are disposed in all safely and in an ecological manner.
- Be careful of the risk of burning and splashing (exhaust, radiator, engine, etc.).

PLACING THE JIB SAFETY WEDGE

- The machine is equipped with a boom safety wedge (↖ 2 - DESCRIPTION: INSTRUMENTS AND CONTROLS) that must be installed on the lifting cylinder rod when working beneath the boom.

FITTING THE WEDGE

- Fully raise the jib.
- Place the safety wedge 1 on the rod of the lifting cylinder and secure with the rod 2 and the pin 3.
- Slowly lower the jib then stop the hydraulic movements before it comes into contact with the wedge.

REMOVING THE WEDGE

- Fully raise the jib.
- Remove the pin and the rod.
- Return the safety wedge to the storage location provided on the machine.

⚠ IMPORTANT ⚠

Only use the wedge supplied with the machine.

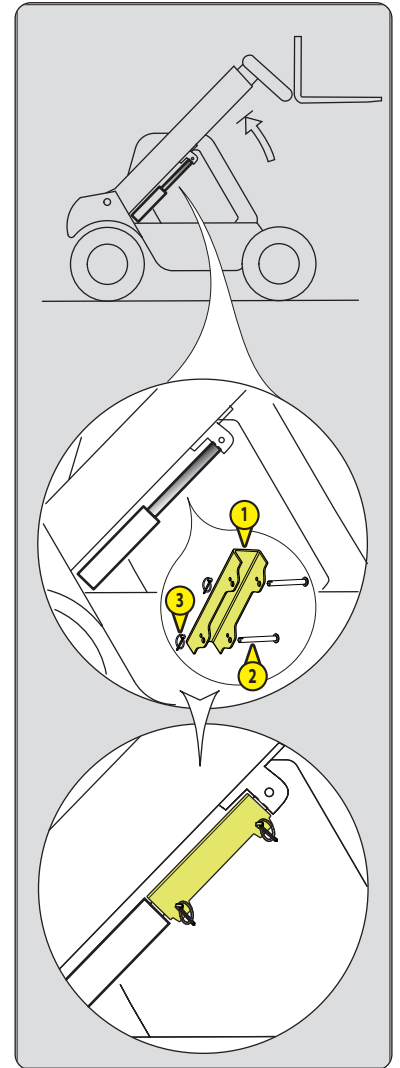

MAINTENANCE

- Perform the periodic service (↖ 3 - MAINTENANCE) to keep your machine in good working order. Failure to perform periodic maintenance may invalidate the contractual warranty.

MAINTENANCE LOGBOOK

- The maintenance operations carried out in accordance with the recommendations given in Part: 3 - MAINTENANCE and the other inspection, servicing or repair operations or modifications performed on the machine or its attachments should be recorded in a maintenance logbook. The entry for each operation should include the date of the work, the names of the individuals or companies having performed them, the type of operation and its frequency, if applicable. If machine elements are replaced, the part numbers of these elements shall be indicated.

LUBRICANT AND FUEL LEVELS

- Use the recommended lubricants (never use contaminated lubricants).
- Do not fill the fuel tank when the engine is running.
- Only fill up the fuel tank in areas specified for this purpose.
- Do not fill the fuel tank to the maximum level.
- Do not smoke or approach the machine with a flame when the fuel tank is open or is being filled.

HYDRAULICS

- Any work on the load handling hydraulic circuit is forbidden except for the operations described in chapter: 3 - MAINTENANCE.
- Do not attempt to loosen unions, hoses or any hydraulic component with the circuit under pressure.

⚠ IMPORTANT ⚠

COUNTERBALANCE VALVE: It is dangerous to change the setting or remove the balancing valves or safety valves which may be fitted to your machine cylinders. The HYDRAULIC ACCUMULATORS which may be fitted on your machine are pressurized units. Removing them and their pipework is dangerous. operation and must only be performed by approved personnel (consult your dealer).

ELECTRICITY

- Do not short-circuit the starter relay to start the engine. If the forward/reverse selector is not in neutral and the parking brake is not on, the machine may suddenly start to move.
- Do not place metal items on the battery.
- Disconnect the battery before working on the electrical circuit.

WELDING

- Disconnect the battery before any welding operations on the machine.
- When carrying out electric welding work on the machine, connect the negative cable from the equipment directly to the part being welded so as to avoid very high current passing through the alternator.
- Never carry out welding or work which gives off heat on an assembled tire. The heat would increase the pressure which could cause the tire to explode.
- If the machine is equipped with an electronic control unit, disconnect it before starting to weld so as to avoid the risk of causing irreparable damage to electronic components.

WASHING THE MACHINE

- Clean the machine or at least the area concerned before any intervention.
- Remember to close and lock all openings on the machine (doors, windows, cowls, etc.).
- During washing, avoid the articulations and electrical components and connections.
- If necessary, protect against penetration of water, steam or cleaning agents, components susceptible of being damaged, particularly electrical components and connections and the injection pump.
- Clean the machine of any traces of fuel, oil or grease.

TRANSPORTING THE MACHINE

⚠ IMPORTANT ⚠

Transporting the machine involves real risks for the operator and others involved.

- Towing, winching, slinging or transporting the machine (⚠ 3 - MAINTENANCE).

PROLONGED MACHINE SHUTDOWN

INTRODUCTION

⚠ IMPORTANT ⚠

Procedures to follow if the machine is not to be used for a long time and for starting it up again afterwards must be performed by your dealership.

This period of long-term stoppage must not exceed 12 months.

After 12 months, repeat the procedures for putting the machine back into service and long-term shutdown.

The recommendations below are intended to prevent the machine from being damaged when it is not used for a period of more than 3 months.

PREPARATION OF THE MACHINE

- Clean the machine thoroughly.
- Check and repair any fuel, oil, water or air leaks.
- Replace or repair any worn or damaged parts.
- Wash the painted surfaces of the machine in clear and cold water and wipe them.
- Touch up the paintwork if necessary.
- Shut down the machine (↩ OPERATING INSTRUCTIONS UNLADEN AND LADEN).
- Make sure the boom cylinder rods are all in the retracted position.
- Release the pressure in the hydraulic circuits.

DEF (Diesel Exhaust Fluid) TANK

Depending on machine model

- Empty and rinse the DEF tank.
- Replace the "DEF" (Diesel Exhaust Fluid) supply pump filter (↩ 3 - MAINTENANCE).
- Slowly fill the tank with new "DEF" (Diesel Exhaust Fluid) up to the bottom of the filler neck.
- Start up the machine to pressurize the circuit and bring it up to working temperature, then shut down the engine.
- If necessary, top up the tank.

PROTECTING THE ENGINE

- Contact your dealer to obtain the procedure for protecting the inside of the engine (use of protection product).
- Fill the tank with fuel (↩ 3 - MAINTENANCE).
- Drain and replace the coolant (↩ 3 - MAINTENANCE).
- Leave the engine running at idling speed for a few minutes, then switch off.
- Replace the engine oil and oil filter (↩ 3 - MAINTENANCE).
- Run the engine for a short time so that the oil and cooling liquid circulate inside.
- Disconnect the battery and store it in a safe place away from the cold, after charging it to a maximum.
- Block the outlet with waterproof adhesive tape.
- Remove the drive belts and store them in a safe place.
- Disconnect the engine cut-off solenoid on the injection pump and carefully insulate the connection.

MACHINE PROTECTION

Place the machine on level ground.

- Set the machine on axle stands so that the tires are off the ground.
- Deactivate the parking brake (depending on machine model).
- Protect cylinder rods which will not be retracted from corrosion.
- Protect the wheels.

N.B.: If the machine is to be stored outdoors, cover it with a waterproof tarpaulin.

RETURNING THE MACHINE TO SERVICE

- Remove the waterproof adhesive tape from all the orifices.
- Remove the protection from the cylinder rods and wheels.
- Refit and reconnect the battery.
- Perform the daily maintenance operations (↩ 3 - MAINTENANCE).
- Perform the weekly maintenance operations (↩ 3 - MAINTENANCE).
- Activate the parking brake and remove the axle stands.
- Drain and clean the fuel tank (↩ 3 - MAINTENANCE).
- Fill the fuel tank with clean diesel filtered through the filler port.
- Replace the fuel filter (↩ 3 - MAINTENANCE).
- Replace the fuel pre-filter (↩ 3 - MAINTENANCE) (depending on the model of machine).
- Drain and rinse the DEF tank (depending on the machine model).
- Top up, slowly fill the tank with new "DEF" (Diesel Exhaust Fluid) up to the bottom of the filler neck (depending on the machine model).
- Refit the drive belts and adjust the tension (↩ 3 - MAINTENANCE).
- Turn the engine over with the starter, to allow the oil pressure to rise.
- Reconnect the engine cut-off solenoid.
- Lubricate the machine completely (↩ 3 - MAINTENANCE).

⚠ IMPORTANT ⚠

Make sure the area is adequately ventilated before starting up the machine.

- Start up the machine, following the operating and safety instructions (↩ OPERATING INSTRUCTIONS UNLADEN AND LADEN).
- Carry out all the boom hydraulic movements, concentrating on the ends of travel for each cylinder.

DISPOSING OF THE MACHINE

⚠ IMPORTANT ⚠

Consult your dealer before disposing of the machine.

RECYCLING OF MATERIALS

METALS

- Metals are 100% recoverable and recyclable.

PLASTICS

- Plastic parts are identified with a marking in accordance with current regulations.
- A limited range of materials is used to simplify the recycling process.
- The majority of the plastic components are made of "thermoplastic" plastics, which are easily recycled by melting, granulating or grinding.

RUBBER

- Tires and seals can be ground for use in cement manufacture or to obtain reusable granules.

GLASS

- Glass items can be removed and collected for processing by glaziers.

ENVIRONMENTAL PROTECTION

By entrusting the maintenance of your machine to the MANITOU network, the risk of pollution is limited and the contribution to environmental protection is made.

WORN OR DAMAGED PARTS

- Do not dump them in the countryside.
- MANITOU and its network have signed-up to a scheme of environmental protection through recycling.

USED OIL

- The MANITOU network organizes the collection and processing of used oil.
- By handing over your waste oil to MANITOU, the risk of pollution is limited.

USED BATTERIES

- Do not throw away batteries, as they contain metals that are harmful for the environment.
- Return them to the MANITOU network or any other approved collection point.

N.B.: MANITOU aims to manufacture machines that provide the best performance and limit polluting emissions.

2 - DESCRIPTION

2 - DESCRIPTION

PARTICULATE FILTER / SPARK ARRESTOR CERTIFICATE OF CONFORMITY	2-4
SAFETY PLATES AND STICKERS	2-6
MACHINE IDENTIFICATION	2-12
CHARACTERISTICS MT 735 75D ST5 S1	2-14
CHARACTERISTICS MT 935 75D ST5 S1	2-17
CHARACTERISTICS MT 1135 75D ST5 S1	2-20
CHARACTERISTICS MT 1335 75D ST5 S1	2-23
CHARACTERISTICS MT 1335 100D ST5 S2	2-26
TIRES	2-29
DIMENSIONS MT 735 75D ST5 S1	2-34
DIMENSIONS MT 935 75D ST5 S1	2-36
DIMENSIONS MT 1135 75D ST5 S1	2-38
DIMENSIONS MT 1335 75D ST5 S1 MT 1335 100D ST5 S2	2-40
LOAD CHARTS MT 735 75D ST5 S1	2-42
LOAD CHARTS MT 935 75D ST5 S1	2-43
LOAD CHARTS MT 1135 75D ST5 S1	2-44
LOAD CHARTS MT 1335 75D ST5 S1 MT 1335 100D ST5 S2	2-46
VISIBILITY MT 735 ...	2-48
VISIBILITY MT 935 ...	2-49
VISIBILITY MT 1135 ...	2-50
VISIBILITY MT 1335 ...	2-51
INSTRUMENTS AND CONTROLS	2-52
EMERGENCY BRAKE	2-54
EMERGENCY EXIT	2-55
TOWING DEVICE	2-77
DESCRIPTION AND USE OF THE OPTIONS	2-78



(1) Certificate

(2) No. of the Certificate: **BVS 13 H 053 X**
(3) Product: **Particle filter as specified in 14 as spark arrester according to EN 1834**
(4) Manufacturer: **DEUTZ AG**
(5) Address: **Ottostrasse 1
51149 Köln
Germany**

- (6) The design of this product and any acceptable variation thereto are specified in the appendix to this certificate.
- (7) The certification body of DEKRA EXAM GmbH certifies that this product comply with the requirements of the test regulations listed under item 8 below. The test results are recorded in the test and assessment report 13 EXAM 11097 BVS-Fr.
- (8) The requirements of the standard are assured by compliance with
DIN EN 1834-1:2000; Chapter 6.4.2
DIN EN 1834-2:2000; Chapter 6.4.2
DIN EN 1834-3:2000; Chapter 6.3.2
- (9) This Certificate relates only to the design and tests of the specified product in accordance to the test regulations. Further requirements apply to the manufacturing process and supply of this product. These are not covered by this certificate.

DEKRA EXAM GmbH
Bochum, 2014-09-04



Certification body



Special services unit

- (12) Appendix to
- (13) Certificate BVS 13 H 053 X
- (14) 14.1 Subject and Type

Particle filters with the DEUTZ-part numbers 4600864, 4604124, 4601585, 4601448, 4601586, 4601449, 4601505, 4601501, 4601502, 4601503, 4601445, 4601444, 4604068, 4604048, 4603078, 4603083, 4603088, 4603040, 4603044, 662862, 662862 and 662865. These particle filters are used in combination with diesel engines with turbo charger and oxidations catalysts according to table 1.

Table 1: Combinations of particle filters, diesel engines with turbo charger and oxidations catalysts

Motor Type	Engine Code	Particle Filter	Size	Oxidation Catalyst
TCD2.9L4	C4EI**	4600864	5,66"x8,5"	4600862
TCD3.6L4				
TCD2.9L4	C4EI**	4604124	5,66"x8,5"	4600862
TCD3.6L4				
TCD4.1L4	C4EI**	4601585	8,5"x7"	4601583
TCD4.1L4	C4FI**	4601448	8,5"x7"	4601448
TCD4.1L4	C4EI**	4601586	8,5"x8,5"	4601583
TCD4.1L4	C4FI**	4601449	8,5"x8,5"	4601448
TCD6.1L6	C4EI**	4601505	9,5"x8"	4601504
TCD6.1L6	C4FI**	4601501	9,5"x8"	4601500
TCD6.1L6	C4FI**	4601502	9,5"x10"	4601500
TCD6.1L6	C4FI**	4601503	9,5"x12"	4601500
TCD7.8L6	C4FI**	4601445	11,25"x10"	4601443
TCD7.8L6	C4FI**	4601444	11,25"x12"	4601443
TCD3.6L4	CFV***	4604069	8,5"x7"	4604047
TCD4.1L4	CFV***	4604048	8,5"x8,5"	4604047
TCD6.1L6	CFV***	4603078	9,5"x8"	4603073
TCD6.1L6	CFV***	4603083	9,5"x10"	4603073
TCD6.1L6	CFV***	4603088	9,5"x12"	4603073
TCD7.8L6	CFV***	4603040	11,25"x10"	4603033
TCD7.8L6	CFV***	4603044	11,25"x12"	4603033
TCD6.1L6	CFW***	662862	11,25"x8"	n.a.
TTCD6.1L6	CFW***	662862	11,25"x10"	n.a.
TTCD7.8L6	CFW***	662865	11,25"x14"	n.a.

n.a.: not applicable. These types are not used in combination with separate oxidation catalysts. The inlet of these particle filter variants are catalytically coated.

14.2 Description

The particle filters are used to retain soot particles in exhaust fumes of diesel engines. They consist of a ceramic honeycomb body, an oxidation catalyst and a metallic housing with thermal isolation. The exhaust fumes coming from engine enter the metallic housing via the inlet, pass the oxidation catalyst and enter the honeycomb body, where they penetrate ceramic, porous walls (thickness 0.30 mm) of the cells. The particle filters and the honeycomb body can have different diameters and lengths, but the cell density is 310 · 10³ cells/m² for all sizes. The inlet can be axial, perpendicular or with an angle of 45°.

The particle filters were successfully tested according to DIN EN 1834-1:2000, Chapter 6.4.2, DIN EN 1834-2:2000, Chapter 6.4.2 and DIN EN 1834-3:2000, Chapter 6.3.2. The particle filters fulfil the requirements as spark arrester according to DIN EN 1834.

14.3 Parameters

Table 2: Operation parameters of particle filters

Part number	Size	Motor Type	Max. Power		Max. exhaust fumes temperature [°C]
			[kW]	[W/hm ²]	
4600864	5,66"x8,5"	TCD2.9L4	90	24,77	530
4604124	5,66"x8,5"	TCD3.6L4	90	24,77	530
4601585	8,5"x7"	TCD3.6L4	95	15,74	450
4601448	8,5"x7"	TCD4.1L4	95	15,74	450
4601586	8,5"x8,5"	TCD4.1L4	115	16,69	530
4601449	8,5"x8,5"	TCD4.1L4	115	16,69	530
4601505	9,5"x8"	TCD6.1L6	130	15,08	450
4601501	9,5"x8"	TCD6.1L6	130	15,08	450
4601502	9,5"x10"	TCD6.1L6	180	14,85	565
4601503	9,5"x12"	TCD6.1L6	180	13,92	570
4601445	11,25"x10"	TCD7.8L6	200	13,24	500
4601444	11,25"x12"	TCD7.8L6	250	13,79	550
4604069	8,5"x7"	TCD3.6L4	97	15,07	530
4603078	8,5"x8,5"	TCD4.1L4	130	15,08	530
4603083	9,5"x8"	TCD6.1L6	150	14,85	570
4603088	9,5"x12"	TCD6.1L6	150	13,52	540
4603040	9,5"x10"	TCD6.1L6	200	17,37	540
4603044	11,25"x10"	TCD7.8L6	200	14,34	540
4604048	11,25"x12"	TCD7.8L6	120	16,37	530
662862	11,25"x8"	TCD6.1L6	174	14,40	520
662862	11,25"x10"	TTCD6.1L6	211	13,97	640
662865	11,25"x14"	TTCD7.8L6	297	13,76	520

- (15) Test and Assessment Report
13 EXAM 11097 BVS-FI, 2014-09-03
- (16) Special Conditions for Safe Use

The particle filters can only be used as spark arresters in combination with the diesel engines with turbo charger and oxidations catalysts given in table 1.

The function of the particle filters as spark arresters according to DIN EN 1834 was only tested for operation conditions without thermal regeneration of the particles filters. The regeneration of the particle filters is not permitted in hazardous areas.

SAFETY PLATES AND STICKERS

⚠ IMPORTANT ⚠

Clean all stickers and safety plates so that they are legible.
 Any safety plates and stickers which are illegible or damaged must be replaced.
 Check that stickers and safety plates are present after replacing any spare parts.

EXTERNAL PLATES AND STICKERS

REF.	REFERENCE	DESCRIPTION
1	52563320	- Tie-down point
3	275329	- Stabilizer crush hazard MT 1135/1335 ...
4	24653	- Slings point
5	305405	- Diesel fuel
6	307508	- Battery cut-off instruction
7	288430	- Repair instruction
8	296998	- Safety instruction
9	234805	- Hydraulic coupling instruction
10	52593979	- Boom safety
11	52567646	- Emergency output
12	52518055	- Battery repair 5 min
13	52685114	- Air conditioning (OPTION)
14	264476	- Boom electrical predisposition (OPTION)
15	289625	- Easy attachment connection (OPTION)
16	52527898	- Overall height (OPTION)
17	52724662	- Lifting forbidden
18	52780017	- Gearbox oil gage
19	288174	- Repair instruction

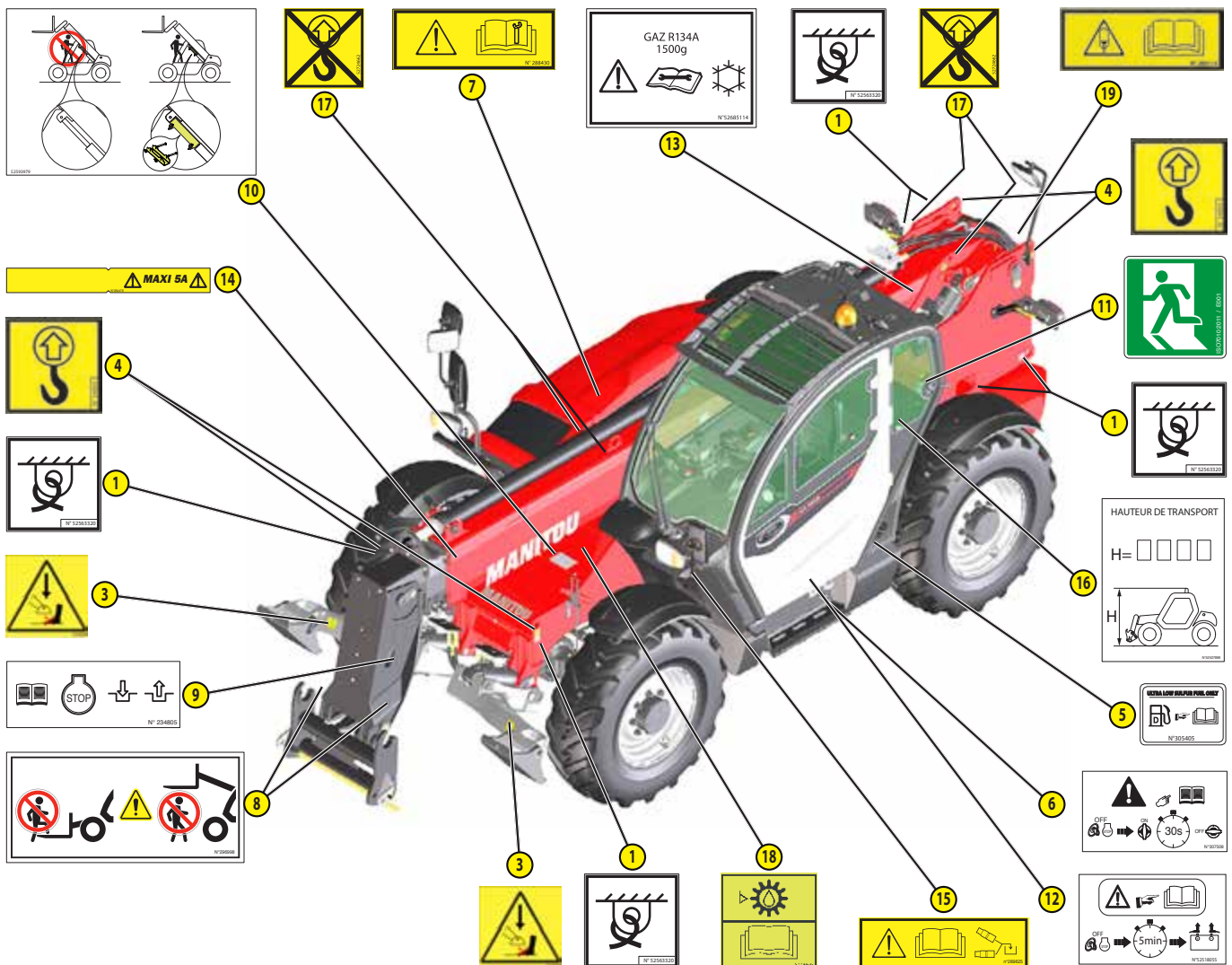

STICKERS AND PLATES UNDER THE ENGINE HOOD

REF.	REFERENCE	DESCRIPTION
1	52656411	- Water/diesel separator
2	52501046	- Anti-freeze
3	52757295	- Engine fuse MT 7/9/11/13 75D ...
	52708618	- Engine fuse MT 13 100D ...
4	52656416	- Electrical hazard
5	244130	- Preheat rod (OPTION)
6	250707	- Fan reversal (OPTION)
7	52778792	- Battery troubleshooting

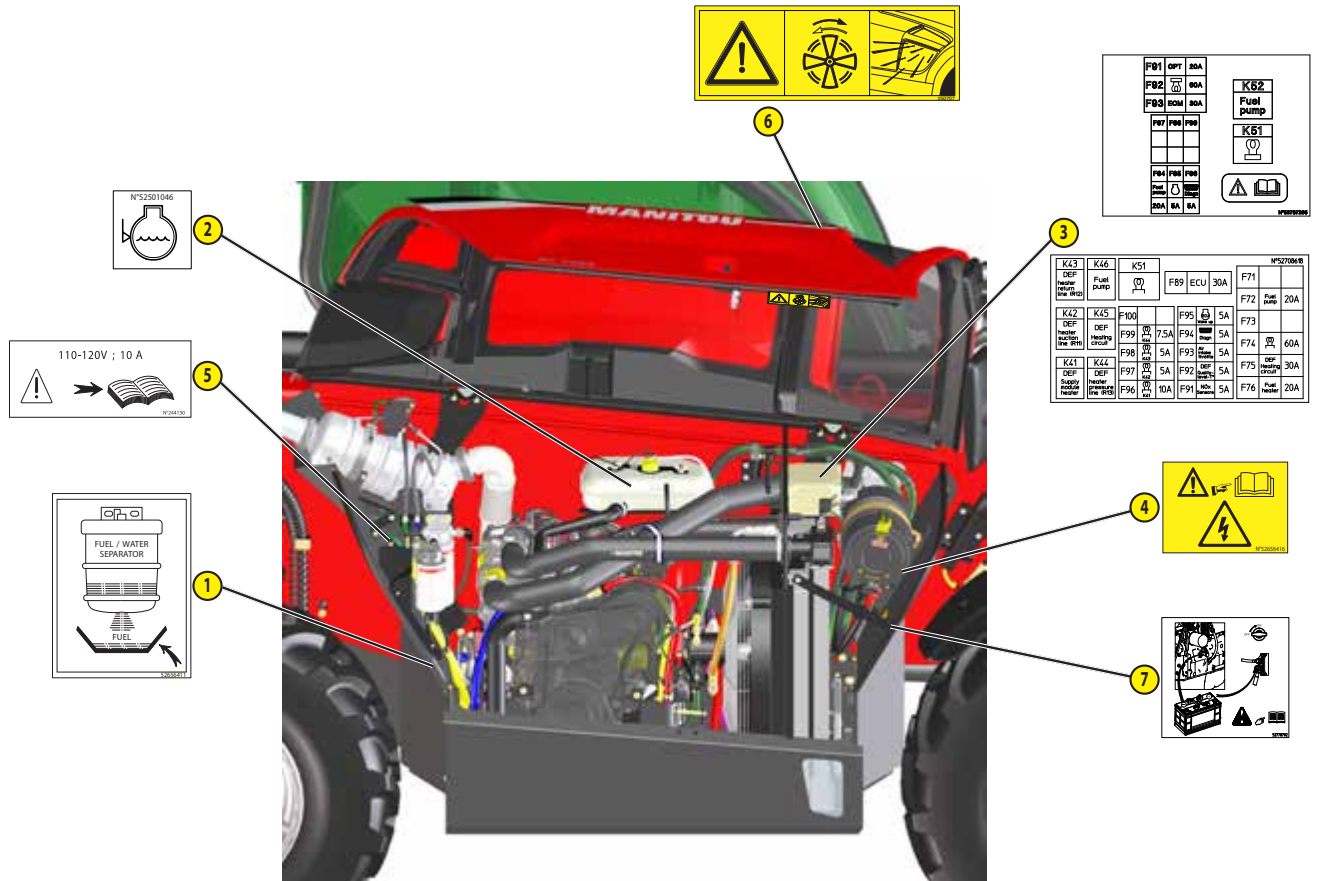

PLATES AND STICKERS IN THE CAB

REF.	REFERENCE	DESCRIPTION
1	268491	- Brake fluid instruction
2	52545464	- Gear selection
4	290183	- Bucket instruction on telescope
5	184276	- Steering selection control
6	223324	- Patents
7	239594	- Sound power level 104 dB MT 7/9/11/13 75D ...
	239596	- Sound power level 106 dB MT 13 100D ...
8	52780560	- Cab compliance MT 735/935/1135 ...
	52733988	- Cab compliance MT 1335 ...
9	52732190	- Fuses and relays
10	52655274	- "Stationary machine" exhaust regeneration
11	52695249	- CACES 9 driving certification requirement (OPTION depending on country)
12	309219	- Boom position
13	265284	- Lifting ring on single carriage (OPTION)
14	52651762	- Hydraulic controls activation
15	52759172	- WARNING risk of misuse (For UK only)

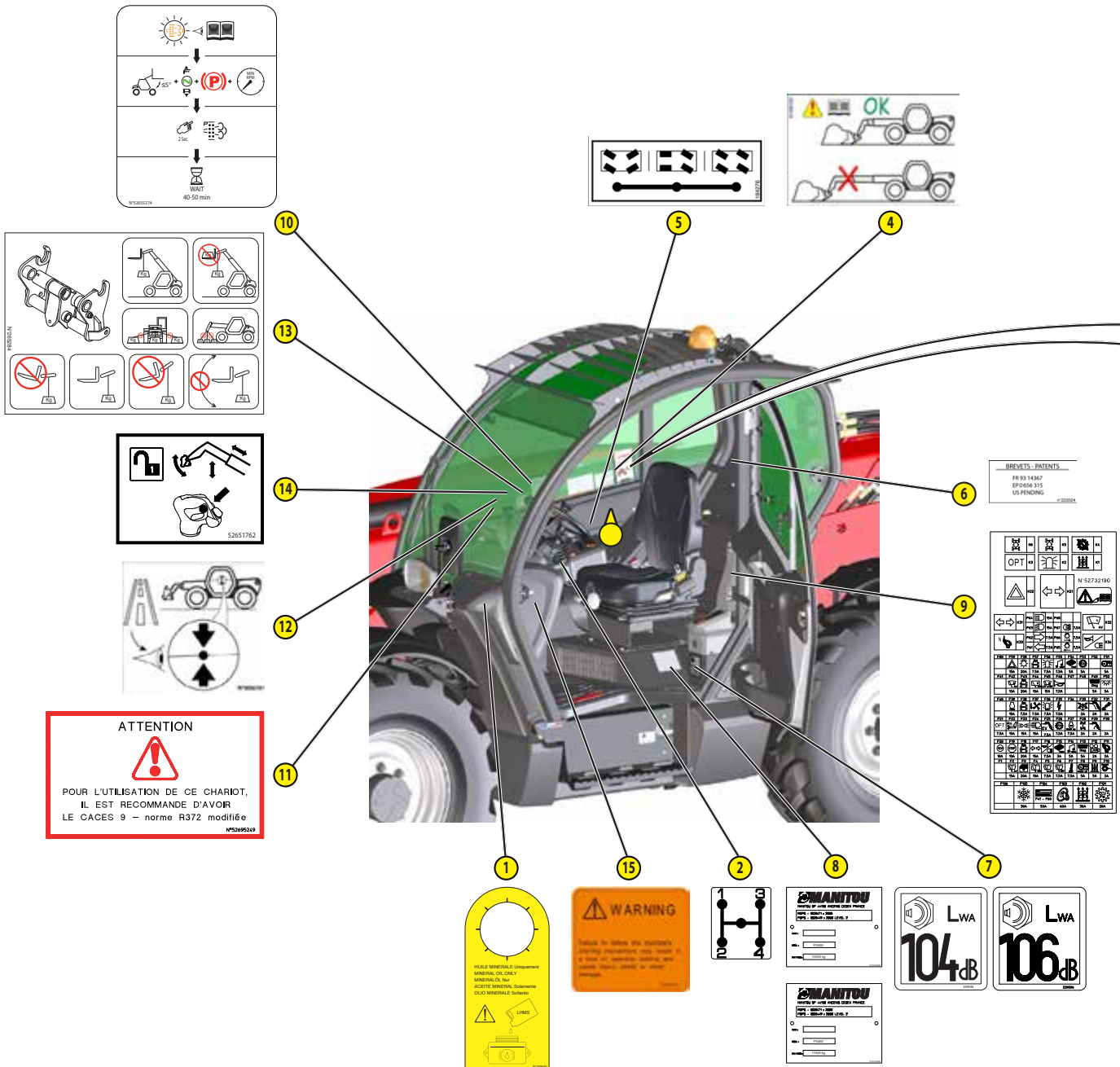

REF.	REFERENCE	DESCRIPTION
1	52699411	- Reach chart sheet
2	241621	- Safety instruction
4	286277	- Joystick function
5	52819211	- Stabilizer and leveling function
6	52753103	- Lubrication sheet
7	52800897	- Tire sheet MT 735 75D ...
	52842996	- Tire sheet MT 935 75D ...
	52846970	- Tire sheet MT 1135 75D ...
	52800900	- Tire sheet MT 1335...
9	52767646	- Hydraulic attachment locking (OPTION)
10	52708709	- Boom head electrovalve (OPTION)
11	52767666	- Boom head electrovalve + hydraulic attachment locking (OPTION)

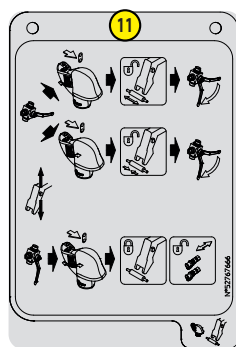
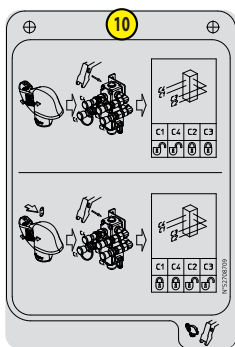
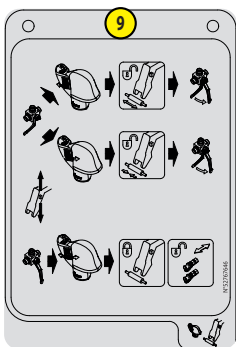
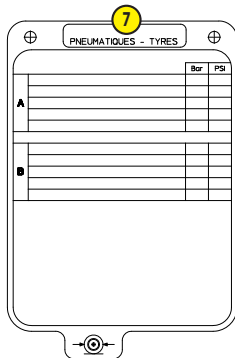
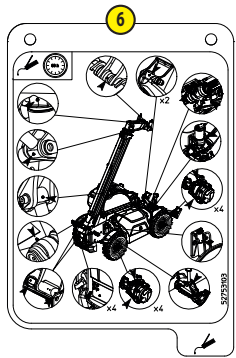
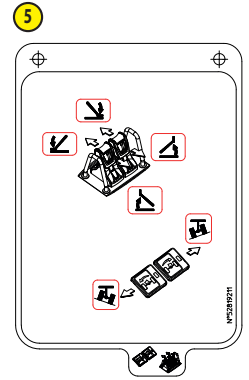
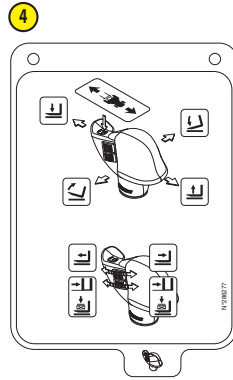

PLATES AND STICKERS IN THE CAB

1	52588614	- No riders
2	52588617	- Seat belt
3	52588616	- DANGER leverage
4	52588615	- Power line
5	52628703	- ADH CAN ICES-2 NMB-2
6	52588612	- Before starting or operating
7	52618159	- PROP 65 warning diesel engine exhaust
8	52618158	- PROP 65 warning plomb

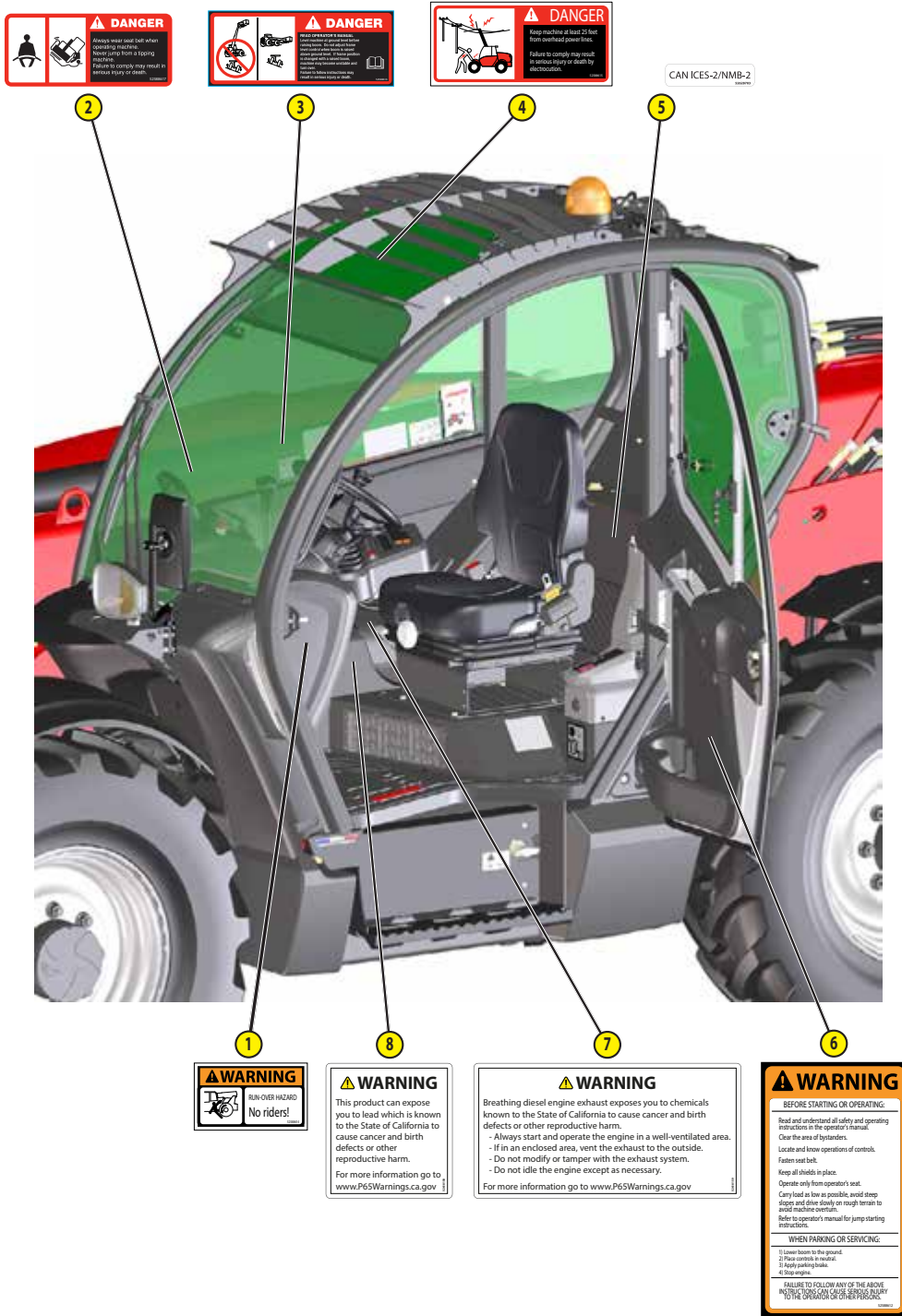

EXTERNAL PLATES AND STICKERS

1	52588611	- Attachment and boom safety
2	52590031	- Attachment retaining shaft

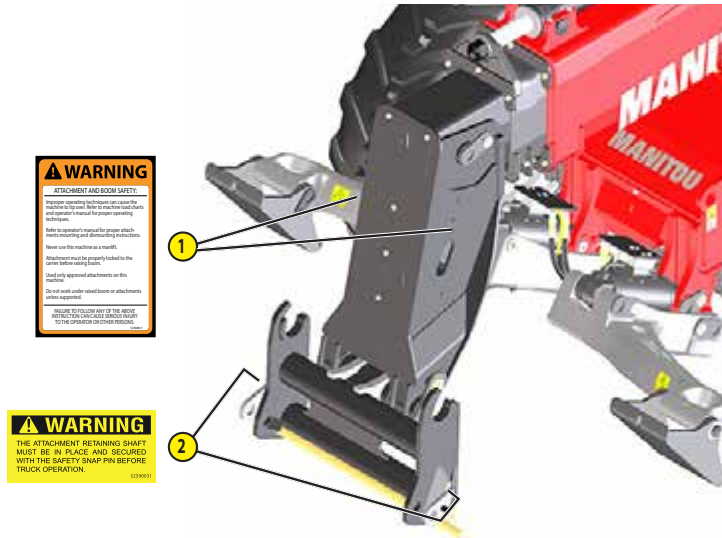

⚠ WARNING
ATTACHMENT AND BOOM SAFETY
 To avoid crushing and laceration injuries, always use the correct attachment and boom safety procedures.
 Refer to operator's manual for proper attachment, boom, and attachment safety procedures.
 Never use this machine as a scaffold.
 Attachments must be properly locked to the correct hitch and boom.
 Use only approved attachments on this machine.
 Do not work under raised booms or attachments unless approved.
 Always follow all of the steps listed below and direct them to the operator or other persons.

⚠ WARNING
 THE ATTACHMENT RETAINING SHAFT MUST BE IN PLACE AND SECURED WITH THE SAFETY SNAP PIN BEFORE TRUCK OPERATION.

STICKERS AND PLATES UNDER THE ENGINE HOOD

1	52589959	- Rotating fan
---	----------	----------------

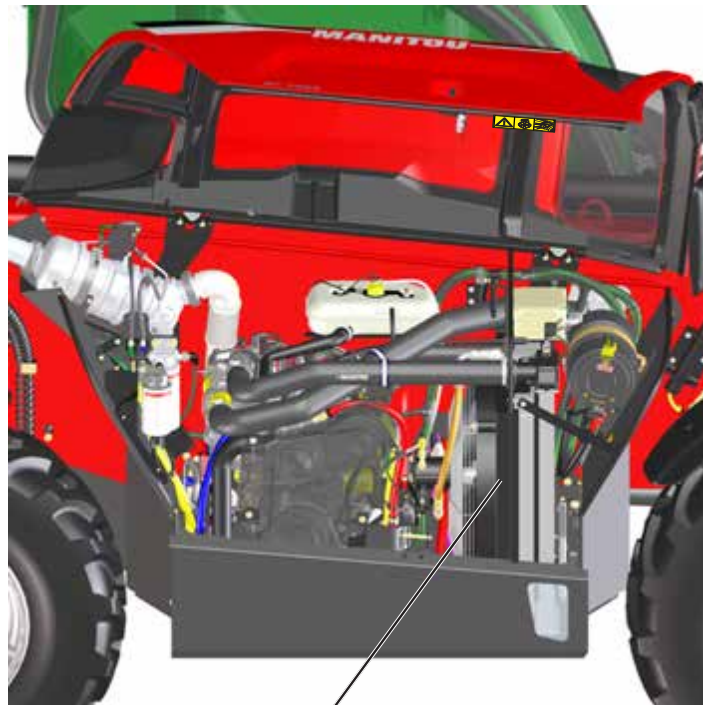

⚠ WARNING
 KEEP HANDS AND CLOTHING AWAY FROM ROTATING FAN AND BELTS TO PREVENT SERIOUS INJURY.
 52589959

MACHINE IDENTIFICATION

As our policy is to promote constant improvement of our products, our range of machines may undergo certain modifications, without obligation for us to advise our customers.

When you order parts, or when you require any technical information, always specify:

N.B.: In order to have all these numbers on hand when needed, it is recommended that they are noted in the spaces provided, at the time of the delivery of the machine.

For any further technical information regarding your machine refer to chapter: CHARACTERISTICS.

MACHINE MANUFACTURER'S PLATE

"Designation" Designation	
"Series" Standard	
"Year of manufacture" Year of manufacture	
"Model year" Model year	
"Serial Number / Product Identification Number" Serial number / Product Identification Number	
"Unladen mass" Unladen weight	
"Power" Power	
"Authorized gross vehicle weight" Authorized Gross Vehicle Weight	
"Rated capacity" Rated capacity	
"Max vertical force (on trailer hook)" Maximum vertical force (on trailer hook)	
"Drag strain" Tractive force	



ENGINE		
Type		DEUTZ TCD2.9L 2501-7118
Fuel		Diesel
Number of cylinders		4 in line
Suction		Turbocharged
Injection system		BOSCH EMRS
Ignition sequence		1-3-4-2
Displacement	cm ³	2924
Bore and stroke	mm	92 x 110
Compression ratio		17.8
Nominal speed laden	rpm	2300
Min. rpm unladen	rpm	930
Max. rpm unladen	rpm	2450
Power ISO/TR 14396	hp - kW	75 - 55.4
Power SAE J 1995	hp - kW	75 - 55.4
Maximum torque ISO/TR 14396	Nm	375 at 1400 rpm
Air filtration efficiency	%	99.9
Type of cooling		Water
Fan		Suction

TRANSMISSION		
Gearbox		CATERPILLAR
- Type		Mechanics
- Shuttle lever		Electro-hydraulics
- Torque converter		ZF
- Number of forward speeds		4
- Number of reverse speeds		4
Angle gearbox		COMER
Front axle		DANA
- Differential		Without locking
Rear axle		DANA
- Differential		Without locking
Drive wheels		4
- 2/4 wheel drive control		no
Front tires		APOLLO
- Size		400/80-24 162A8 FX525
- Pressure	bar	4.5
Rear tires		APOLLO
- Size		400/80-24 162A8 FX525
- Pressure	bar	4.5

ELECTRIC CIRCUIT		
Battery	STANDARD	12 V - 110 Ah - 900 A EN
	OPTION	12 V - 180 Ah - 1000 A EN
Alternator		14 V - 95 A
- Type		MAHLE AAK4721
Starter		12 V - 3.2 kW
- Type		MAHLE AZE4224

BRAKE SYSTEM		
Service brake		Hydraulic power brake
- Type of brake		Oil-immersed multi-disc
- Type of order		Foot-operated for the front and rear axles
Parking brake		Low pressure brake
- Type of brake		SAHR
- Type of order		Electro-hydraulic

HYDRAULIC CIRCUIT			
Hydraulic pump		Swashplate piston pump	
- Type		1st housing	2nd casing
- Displacement	cm ³	54	17
- Max. rating capacity unladen	L/min	132	41
- Flow at 1600 rpm	L/min	86	27
Filtration			
- Back	µm	11	11
- Suction	µm	135	135
Maximum working pressure	bar	270	
- Telescoping circuit	bar	200 / 270	
- Lift circuit	bar	270 / 270	
- Tilt circuit	bar	270 / 230	
- Circuit stabilizers	bar	-	
- Frame leveling circuit (OPTION)	bar	-	
- Attachment circuit (OPTION)	bar	270	
- Steering circuit	bar	140	

HYDRAULIC MOVEMENTS			
Lifting motions (boom retracted)			
- Unladen lifting	s - m/min	6.6-40.5	
- Laden lifting	s - m/min	11.2-23.9	
- Unladen lowering	s - m/min	5-53.5	
- Laden lowering	s - m/min	5.2-51.5	
Telescoping motions (boom raised)			
- Unladen extending	s - m/min	5.8-28.4	
- Laden extending	s - m/min	5.9-28.9	
- Unladen retracting	s - m/min	4.4-38	
- Laden retracting	s - m/min	4.6-36.4	
Tilting movements			
- Unladen digging	s - °/s	3.1-40.7	
- Unladen dump	s - °/s	3.1-40.7	

SOUND AND VIBRATION			
Sound pressure level in the driver's cab LpA (according to standard NF EN 12053)	dB(A)	77	
Sound pressure (according to Directive 2009/76)	dB(A)		
Guaranteed sound power level in the environment LwA (according to Directive 2000/14/EC modified by Directive 2005/88/EC)	dB(A)	104	
Sound level in motion (according to Directive 2009/63)	dB(A)		
Average weighted acceleration on driver's body (according to standard NF EN 13059)	m/s ²	2	
The average weighted acceleration transmitted to the driver's hand/ arm system (according to standard ISO 5349-2)	m/s ²	<2.5	
Standard seat vibration	m/s ²		

SPECIFICATIONS AND WEIGHTS			
Speed of movement for machine in standard configuration on flat ground			
- Front unladen	1	km/h	4
	2	km/h	6.5
	3	km/h	13.8
	4	km/h	24.5
- Rear unladen	1	km/h	4
	2	km/h	6.5
	3	km/h	13.8
	4	km/h	24.5
Standard attachment			CAF 1040/4.1
- Weight with forks		kg	190
- Weight of forks (each)		kg	60
Rated capacity with standard attachment		kg	3500
Tipping load at maximum reach on stabilizers		kg	-
Distance from the center of gravity of the load to the base of the forks		mm	500
Standard lifting height		mm	-
Weight of machine without attachment		kg	6550
Weight of machine with standard attachment			
- Unladen		kg	6860
- At rated load		kg	10360
Weight per axle with standard attachment (transport position)			
- Front unladen		kg	3200
- Rear unladen		kg	3660
- Front rated load		kg	9050
- Rear rated load		kg	1310
Weight per axle with standard attachment (boom extended)			
- Front rated load		kg	7480
- Rear rated load		kg	530
Contact pressure on the ground of the total surface of each stabilizer at maximum tipping load		kg/cm ²	-
Tractive effort on the coupling hook			
- Unladen (sliding)		daN	5230
- At rated load (transmission setting)		daN	8200
Break-out force with bucket (according to standard ISO 8313)		daN	6980

ENGINE		
Type		DEUTZ TCD2.9L 2501-7118
Fuel		Diesel
Number of cylinders		4 in line
Suction		Turbocharged
Injection system		BOSCH EMRS
Ignition sequence		1-3-4-2
Displacement	cm ³	2924
Bore and stroke	mm	92 x 110
Compression ratio		17.8
Nominal speed laden	rpm	2300
Min. rpm unladen	rpm	930
Max. rpm unladen	rpm	2450
Power ISO/TR 14396	hp - kW	75 - 55.4
Power SAE J 1995	hp - kW	75 - 55.4
Maximum torque ISO/TR 14396	Nm	375 at 1400 rpm
Air filtration efficiency	%	99.9
Type of cooling		Water
Fan		Suction

TRANSMISSION		
Gearbox		CATERPILLAR
- Type		Mechanics
- Shuttle lever		Electro-hydraulics
- Torque converter		ZF
- Number of forward speeds		4
- Number of reverse speeds		4
Angle gearbox		COMER
Front axle		DANA
- Differential		Without locking
Rear axle		DANA
- Differential		Without locking
Drive wheels		4
- 2/4 wheel drive control		no
Front tires		APOLLO
- Size		400/80-24 162A8 FX525
- Pressure	bar	5
Rear tires		APOLLO
- Size		400/80-24 162A8 FX525
- Pressure	bar	5

ELECTRIC CIRCUIT		
Battery	STANDARD	12 V - 110 Ah - 900 A EN
	OPTION	12 V - 180 Ah - 1000 A EN
Alternator		14 V - 95 A
- Type		MAHLE AAK4721
Starter		12 V - 3.2 kW
- Type		MAHLE AZE4224

BRAKE SYSTEM		
Service brake		Hydraulic power brake
- Type of brake		Oil-immersed multi-disc
- Type of order		Foot-operated for the front and rear axles
Parking brake		Low pressure brake
- Type of brake		SAHR
- Type of order		Electro-hydraulic

HYDRAULIC CIRCUIT			
Hydraulic pump		Swashplate piston pump	
- Type		1st housing	2nd casing
- Displacement	cm ³	54	17
- Max. rating capacity unladen	L/min	132	41
- Flow at 1600 rpm	L/min	86	27
Filtration			
- Back	µm	11	11
- Suction	µm	135	135
Maximum working pressure		270	
- Telescoping circuit	bar	200 / 270	
- Lift circuit	bar	270 / 270	
- Tilt circuit	bar	270 / 230	
- Circuit stabilizers	bar	-	
- Frame leveling circuit (OPTION)	bar	-	
- Attachment circuit (OPTION)	bar	270	
- Steering circuit	bar	140	

HYDRAULIC MOVEMENTS			
Lifting motions (boom retracted)			
- Unladen lifting	s - m/min	6.6-40.5	
- Laden lifting	s - m/min	11.2-23.9	
- Unladen lowering	s - m/min	5-53.5	
- Laden lowering	s - m/min	5.2-51.5	
Telescoping motions (boom raised)			
- Unladen extending	s - m/min	5.8-28.4	
- Laden extending	s - m/min	5.9-28.9	
- Unladen retracting	s - m/min	4.4-38	
- Laden retracting	s - m/min	4.6-36.4	
Tilting movements			
- Unladen digging	s - °/s	3.1-40.7	
- Unladen dump	s - °/s	3.1-40.7	

SOUND AND VIBRATION			
Sound pressure level in the driver's cab LpA (according to standard NF EN 12053)	dB(A)	77	
Sound pressure (according to Directive 2009/76)	dB(A)		
Guaranteed sound power level in the environment LwA (according to Directive 2000/14/EC modified by Directive 2005/88/EC)	dB(A)	104	
Sound level in motion (according to Directive 2009/63)	dB(A)		
Average weighted acceleration on driver's body (according to standard NF EN 13059)	m/s ²	2	
The average weighted acceleration transmitted to the driver's hand/ arm system (according to standard ISO 5349-2)	m/s ²	<2.5	
Standard seat vibration	m/s ²		

SPECIFICATIONS AND WEIGHTS			
Speed of movement for machine in standard configuration on flat ground			
- Front unladen	1	km/h	4
	2	km/h	6.5
	3	km/h	13.8
	4	km/h	24.5
- Rear unladen	1	km/h	4
	2	km/h	6.5
	3	km/h	13.8
	4	km/h	24.5
Standard attachment			CAF 1040/4.1
- Weight with forks		kg	190
- Weight of forks (each)		kg	60
Rated capacity with standard attachment		kg	3500
Tipping load at maximum reach on stabilizers		kg	-
Distance from the center of gravity of the load to the base of the forks		mm	500
Standard lifting height		mm	9061
Weight of machine without attachment		kg	7150
Weight of machine with standard attachment			
- Unladen		kg	7460
- At rated load		kg	10960
Weight per axle with standard attachment (transport position)			
- Front unladen		kg	3480
- Rear unladen		kg	3980
- Front rated load		kg	9290
- Rear rated load		kg	1670
Weight per axle with standard attachment (boom extended)			
- Front rated load		kg	7440
- Rear rated load		kg	520
Contact pressure on the ground of the total surface of each stabilizer at maximum tipping load		kg/cm ²	-
Tractive effort on the coupling hook			
- Unladen (sliding)		daN	5800
- At rated load (transmission setting)		daN	8500
Break-out force with bucket (according to standard ISO 8313)		daN	7180

ENGINE		
Type		DEUTZ TCD2.9L 2501-7118
Fuel		Diesel
Number of cylinders		4 in line
Suction		Turbocharged
Injection system		BOSCH EMRS
Ignition sequence		1-3-4-2
Displacement	cm ³	2924
Bore and stroke	mm	92 x 110
Compression ratio		17.8
Nominal speed laden	rpm	2300
Min. rpm unladen	rpm	930
Max. rpm unladen	rpm	2484
Power ISO/TR 14396	hp - kW	75 - 55.4
Power SAE J 1995	hp - kW	75 - 55.4
Maximum torque ISO/TR 14396	Nm	375 at 1400 rpm
Air filtration efficiency	%	99.9
Type of cooling		Water
Fan		Suction

TRANSMISSION		
Gearbox		CATERPILLAR
- Type		Mechanics
- Shuttle lever		Electro-hydraulics
- Torque converter		ZF
- Number of forward speeds		4
- Number of reverse speeds		4
Angle gearbox		COMER
Front axle		DANA
- Differential		Without locking
Rear axle		DANA
- Differential		Without locking
Drive wheels		4
- 2/4 wheel drive control		no
Front tires		APOLLO
- Size		400/80-24 162A8 FX525
- Pressure	bar	5
Rear tires		APOLLO
- Size		400/80-24 162A8 FX525
- Pressure	bar	5

ELECTRIC CIRCUIT		
Battery	STANDARD	12 V - 110 Ah - 900 A EN
	OPTION	12 V - 180 Ah - 1000 A EN
Alternator		14 V - 95 A
- Type		MAHLE AAK4721
Starter		12 V - 3.2 kW
- Type		MAHLE AZE4224

BRAKE SYSTEM		
Service brake		Hydraulic power brake
- Type of brake		Oil-immersed multi-disc
- Type of order		Foot-operated for the front and rear axles
Parking brake		Low pressure brake
- Type of brake		SAHR
- Type of order		Electro-hydraulic

HYDRAULIC CIRCUIT			
Hydraulic pump		Swashplate piston pump	
- Type		1st housing	2nd casing
- Displacement	cm ³	54	17
- Max. rating capacity unladen	L/min	133	42
- Flow at 1600 rpm	L/min	86	27
Filtration			
- Back	µm	11	11
- Suction	µm	135	135
Maximum working pressure		270	
- Telescoping circuit	bar	200 / 270	
- Lift circuit	bar	270 / 270	
- Tilt circuit	bar	270 / 230	
- Circuit stabilizers	bar	270	
- Frame leveling circuit (OPTION)	bar	270	
- Attachment circuit (OPTION)	bar	270	
- Steering circuit	bar	140	

HYDRAULIC MOVEMENTS			
Lifting motions (boom retracted)			
- Unladen lifting	s - m/min	7.6-42.4	
- Laden lifting	s - m/min	12.4-26	
- Unladen lowering	s - m/min	5.4-59.6	
- Laden lowering	s - m/min	5.8-55.5	
Telescoping motions (boom raised)			
- Unladen extending	s - m/min	12.3-14.1	
- Laden extending	s - m/min	12.3-14.1	
- Unladen retracting	s - m/min	8.2-21.1	
- Laden retracting	s - m/min	7.7-22.5	
Tilting movements			
- Unladen digging	s - °/s	3.1-40.7	
- Unladen dump	s - °/s	3.6-35.1	

SOUND AND VIBRATION			
Sound pressure level in the driver's cab LpA (according to standard NF EN 12053)	dB(A)	77	
Sound pressure (according to Directive 2009/76)	dB(A)		
Guaranteed sound power level in the environment LwA (according to Directive 2000/14/EC modified by Directive 2005/88/EC)	dB(A)	104	
Sound level in motion (according to Directive 2009/63)	dB(A)		
Average weighted acceleration on driver's body (according to standard NF EN 13059)	m/s ²	2	
The average weighted acceleration transmitted to the driver's hand/ arm system (according to standard ISO 5349-2)	m/s ²	<2.5	
Standard seat vibration	m/s ²		

SPECIFICATIONS AND WEIGHTS			
Speed of movement for machine in standard configuration on flat ground			
- Front unladen	1	km/h	4
	2	km/h	6.5
	3	km/h	13.8
	4	km/h	24.5
- Rear unladen	1	km/h	4
	2	km/h	6.5
	3	km/h	13.8
	4	km/h	24.5
Standard attachment			CAF 1040/4.1
- Weight with forks		kg	190
- Weight of forks (each)		kg	60
Rated capacity with standard attachment		kg	3500
Tipping load at maximum reach on stabilizers		kg	1000
Distance from the center of gravity of the load to the base of the forks		mm	500
Standard lifting height		mm	10902
Weight of machine without attachment		kg	8050
Weight of machine with standard attachment			
- Unladen		kg	8360
- At rated load		kg	11860
Weight per axle with standard attachment (transport position)			
- Front unladen		kg	4550
- Rear unladen		kg	3810
- Front rated load		kg	10850
- Rear rated load		kg	1010
Weight per axle with standard attachment (boom extended)			
- Front rated load		kg	8220
- Rear rated load		kg	390
Contact pressure on the ground of the total surface of each stabilizer at maximum tipping load		kg/cm ²	6.2
Tractive effort on the coupling hook			
- Unladen (sliding)		daN	6000
- At rated load (transmission setting)		daN	8400
Break-out force with bucket (according to standard ISO 8313)		daN	6850

ENGINE		
Type		DEUTZ TCD2.9L 2501-7118
Fuel		Diesel
Number of cylinders		4 in line
Suction		Turbocharged
Injection system		BOSCH EMRS
Ignition sequence		1-3-4-2
Displacement	cm ³	2924
Bore and stroke	mm	92 x 110
Compression ratio		17.8
Nominal speed laden	rpm	2300
Min. rpm unladen	rpm	930
Max. rpm unladen	rpm	2484
Power ISO/TR 14396	hp - kW	75 - 55.4
Power SAE J 1995	hp - kW	75 - 55.4
Maximum torque ISO/TR 14396	Nm	375 at 1400 rpm
Air filtration efficiency	%	99.9
Type of cooling		Water
Fan		Suction

TRANSMISSION		
Gearbox		CATERPILLAR
- Type		Mechanics
- Shuttle lever		Electro-hydraulics
- Torque converter		ZF
- Number of forward speeds		4
- Number of reverse speeds		4
Angle gearbox		COMER
Front axle		DANA
- Differential		Without locking
Rear axle		DANA
- Differential		Without locking
Drive wheels		4
- 2/4 wheel drive control		no
Front tires		APOLLO
- Size		400/80-24 162A8 FX525
- Pressure	bar	5
Rear tires		APOLLO
- Size		400/80-24 162A8 FX525
- Pressure	bar	5

ELECTRIC CIRCUIT		
Battery	STANDARD	12 V - 110 Ah - 900 A EN
	OPTION	12 V - 180 Ah - 1000 A EN
Alternator		14 V - 95 A
- Type		MAHLE AAK4721
Starter		12 V - 3.2 kW
- Type		MAHLE AZE4224

BRAKE SYSTEM		
Service brake		Hydraulic power brake
- Type of brake		Oil-immersed multi-disc
- Type of order		Foot-operated for the front and rear axles
Parking brake		Low pressure brake
- Type of brake		SAHR
- Type of order		Electro-hydraulic

HYDRAULIC CIRCUIT			
Hydraulic pump		Swashplate piston pump	
- Type		1st housing	2nd casing
- Displacement	cm ³	54	17
- Max. rating capacity unladen	L/min	133	42
- Flow at 1600 rpm	L/min	86	27
Filtration			
- Back	µm	11	11
- Suction	µm	135	135
Maximum working pressure		270	
- Telescoping circuit	bar	200 / 270	
- Lift circuit	bar	270 / 270	
- Tilt circuit	bar	270 / 230	
- Circuit stabilizers	bar	270	
- Frame leveling circuit (OPTION)	bar	270	
- Attachment circuit (OPTION)	bar	270	
- Steering circuit	bar	140	

HYDRAULIC MOVEMENTS			
Lifting motions (boom retracted)			
- Unladen lifting	s - m/min	10.3-33.7	
- Laden lifting	s - m/min	15.1-23	
- Unladen lowering	s - m/min	9.6-36.1	
- Laden lowering	s - m/min	7.7-45	
Telescoping motions (boom raised)			
- Unladen extending	s - m/min	14.7-13.2	
- Laden extending	s - m/min	16-14.4	
- Unladen retracting	s - m/min	9.9-21.4	
- Laden retracting	s - m/min	8.9-23.8	
Tilting movements			
- Unladen digging	s - °/s	3.2-39.4	
- Unladen dump	s - °/s	3.8-33.2	

SOUND AND VIBRATION			
Sound pressure level in the driver's cab LpA (according to standard NF EN 12053)	dB(A)	77	
Sound pressure (according to Directive 2009/76)	dB(A)		
Guaranteed sound power level in the environment LwA (according to Directive 2000/14/EC modified by Directive 2005/88/EC)	dB(A)	104	
Sound level in motion (according to Directive 2009/63)	dB(A)		
Average weighted acceleration on driver's body (according to standard NF EN 13059)	m/s ²	2	
The average weighted acceleration transmitted to the driver's hand/ arm system (according to standard ISO 5349-2)	m/s ²	<2.5	
Standard seat vibration	m/s ²		

SPECIFICATIONS AND WEIGHTS			
Speed of movement for machine in standard configuration on flat ground			
- Front unladen	1	km/h	4
	2	km/h	6.5
	3	km/h	13.8
	4	km/h	24.5
- Rear unladen	1	km/h	4
	2	km/h	6.5
	3	km/h	13.8
	4	km/h	24.5
Standard attachment			CAF 1040/4.1
- Weight with forks		kg	190
- Weight of forks (each)		kg	60
Rated capacity with standard attachment		kg	3500
Tipping load at maximum reach on stabilizers		kg	1000
Distance from the center of gravity of the load to the base of the forks		mm	500
Standard lifting height		mm	12653
Weight of machine without attachment		kg	8950
Weight of machine with standard attachment			
- Unladen		kg	9260
- At rated load		kg	12760
Weight per axle with standard attachment (transport position)			
- Front unladen		kg	4230
- Rear unladen		kg	5030
- Front rated load		kg	10890
- Rear rated load		kg	1870
Weight per axle with standard attachment (boom extended)			
- Front rated load		kg	9100
- Rear rated load		kg	460
Contact pressure on the ground of the total surface of each stabilizer at maximum tipping load		kg/cm ²	6.6
Tractive effort on the coupling hook			
- Unladen (sliding)		daN	6600
- At rated load (transmission setting)		daN	9700
Break-out force with bucket (according to standard ISO 8313)		daN	7400

ENGINE		
Type		DEUTZ TCD 3.6 L 2501-4428
Fuel		Diesel
Number of cylinders		4 in line
Suction		Turbocharged
Injection system		BOSCH EMRS
Ignition sequence		1-3-4-2
Displacement	cm ³	3621
Bore and stroke	mm	98 x 120
Compression ratio		17.2
Nominal speed laden	rpm	2300
Min. rpm unladen	rpm	930
Max. rpm unladen	rpm	2484
Power ISO/TR 14396	hp - kW	101 - 74.4
Power SAE J 1995	hp - kW	101 - 74.4
Maximum torque ISO/TR 14396	Nm	410 at 1,600 rpm
Air filtration efficiency	%	99.9
Type of cooling		Water
Fan		Suction

TRANSMISSION		
Gearbox		CATERPILLAR
- Type		Mechanics
- Shuttle lever		Electro-hydraulics
- Torque converter		ZF
- Number of forward speeds		4
- Number of reverse speeds		4
Angle gearbox		COMER
Front axle		DANA
- Differential		Without locking
Rear axle		DANA
- Differential		Without locking
Drive wheels		4
- 2/4 wheel drive control		no
Front tires		APOLLO
- Size		400/80-24 162A8 FX525
- Pressure	bar	5
Rear tires		APOLLO
- Size		400/80-24 162A8 FX525
- Pressure	bar	5

ELECTRIC CIRCUIT		
Battery	STANDARD	12 V - 110 Ah - 900 A EN
	OPTION	12 V - 180 Ah - 1000 A EN
Alternator		14 V - 95 A
- Type		MAHLE AAK4720
Starter		12 V - 4 kW
- Type		MAHLE AZF4814

BRAKE SYSTEM		
Service brake		Hydraulic power brake
- Type of brake		Oil-immersed multi-disc
- Type of order		Foot-operated for the front and rear axles
Parking brake		Low pressure brake
- Type of brake		SAHR
- Type of order		Electro-hydraulic

HYDRAULIC CIRCUIT			
Hydraulic pump		Swashplate piston pump	
- Type		1st housing	2nd casing
- Displacement	cm ³	54	17
- Max. rating capacity unladen	L/min	133	42
- Flow at 1600 rpm	L/min	86	27
Filtration			
- Back	µm	11	11
- Suction	µm	135	135
Maximum working pressure	bar	270	
- Telescoping circuit	bar	200 / 270	
- Lift circuit	bar	270 / 270	
- Tilt circuit	bar	270 / 230	
- Circuit stabilizers	bar	270	
- Frame leveling circuit (OPTION)	bar	270	
- Attachment circuit (OPTION)	bar	270	
- Steering circuit	bar	140	

HYDRAULIC MOVEMENTS			
Lifting motions (boom retracted)			
- Unladen lifting	s - m/min	10.3-33.7	
- Laden lifting	s - m/min	15.1-23	
- Unladen lowering	s - m/min	9.6-36.1	
- Laden lowering	s - m/min	7.7-45	
Telescoping motions (boom raised)			
- Unladen extending	s - m/min	14.7-13.2	
- Laden extending	s - m/min	16-14.4	
- Unladen retracting	s - m/min	9.9-21.4	
- Laden retracting	s - m/min	8.9-23.8	
Tilting movements			
- Unladen digging	s - °/s	3.2-39.4	
- Unladen dump	s - °/s	3.8-33.2	

SOUND AND VIBRATION			
Sound pressure level in the driver's cab LpA (according to standard NF EN 12053)	dB(A)	77	
Sound pressure (according to Directive 2009/76)	dB(A)		
Guaranteed sound power level in the environment LwA (according to Directive 2000/14/EC modified by Directive 2005/88/EC)	dB(A)	106	
Sound level in motion (according to Directive 2009/63)	dB(A)		
Average weighted acceleration on driver's body (according to standard NF EN 13059)	m/s ²	2	
The average weighted acceleration transmitted to the driver's hand/ arm system (according to standard ISO 5349-2)	m/s ²	<2.5	
Standard seat vibration	m/s ²		

SPECIFICATIONS AND WEIGHTS			
Speed of movement for machine in standard configuration on flat ground			
- Front unladen	1	km/h	4
	2	km/h	6.5
	3	km/h	13.8
	4	km/h	24.5
- Rear unladen	1	km/h	4
	2	km/h	6.5
	3	km/h	13.8
	4	km/h	24.5
Standard attachment			CAF 1040/4.1
- Weight with forks		kg	190
- Weight of forks (each)		kg	60
Rated capacity with standard attachment		kg	3500
Tipping load at maximum reach on stabilizers		kg	1000
Distance from the center of gravity of the load to the base of the forks		mm	500
Standard lifting height		mm	12653
Weight of machine without attachment		kg	9100
Weight of machine with standard attachment			
- Unladen		kg	9410
- At rated load		kg	12910
Weight per axle with standard attachment (transport position)			
- Front unladen		kg	4305
- Rear unladen		kg	5105
- Front rated load		kg	10965
- Rear rated load		kg	1945
Weight per axle with standard attachment (boom extended)			
- Front rated load		kg	9175
- Rear rated load		kg	535
Contact pressure on the ground of the total surface of each stabilizer at maximum tipping load		kg/cm ²	6.6
Tractive effort on the coupling hook			
- Unladen (sliding)		daN	6600
- At rated load (transmission setting)		daN	9700
Break-out force with bucket (according to standard ISO 8313)		daN	7400

TIRES

MT 735 75D ST5 S1

		PRESSURE (bar)	LOAD PER TIRE (kg)			
			FRONT UNLADEN	FRONT (LADEN)	REAR (UNLADEN)	REAR (LADEN)
APOLLO	400/80-R24 20PR 162A8 TL FX525	4,5	1600	4525	1830	655
ALLIANCE	400/80-R24 162A8 A325	3,8				
ALLIANCE	460/70-R24 A585	3,2				
MICHELIN	400/80-R24 162A8 PCL	3,8				
MICHELIN	460/70-R24 159A8 BIB	3				

		PRESSURE (bar)	LOAD (kg)	GROUND CONTACT PRESSURE (kg/cm ²)		GROUND CONTACT AREA (cm ²)	
				HARD GROUND	SOFT GROUND	HARD GROUND	SOFT GROUND
APOLLO	400/80-R24 20PR 162A8 TL FX525	4,5	655				
			1600				
			1830				
			4525				
ALLIANCE	400/80-R24 162A8 A325	3,8	655				
			1600				
			1830				
			4525				
ALLIANCE	460/70-R24 A585	3,2	655				
			1600				
			1830				
			4525				
MICHELIN	400/80-R24 162A8 PCL	3,8	655				
			1600				
			1830				
			4525				
MICHELIN	460/70-R24 159A8 BIB	3	655				
			1600				
			1830				
			4525				

MT 935 75D ST5 S1

		PRESSURE (bar)	LOAD PER TIRE (kg)			
			FRONT UNLADEN	FRONT (LADEN)	REAR (UNLADEN)	REAR (LADEN)
APOLLO	400/80-R24 20PR 162A8 TL FX525	5	1740	4645	1990	835
ALLIANCE	400/80-R24 162A8 A325	4				
ALLIANCE	460/70-R24 A585	3,6				
MICHELIN	400/80-R24 162A8 PCL	4				
MICHELIN	460/70-R24 159A8 BIB	3				

		PRESSURE (bar)	LOAD (kg)	GROUND CONTACT PRESSURE (kg/cm ²)		GROUND CONTACT AREA (cm ²)	
				HARD GROUND	SOFT GROUND	HARD GROUND	SOFT GROUND
APOLLO	400/80-R24 20PR 162A8 TL FX525	5	835				
			1990				
			1740				
			4645				
ALLIANCE	400/80-R24 162A8 A325	4	835				
			1990				
			1740				
			4645				
ALLIANCE	460/70-R24 A585	3,6	835				
			1990				
			1740				
			4645				
MICHELIN	400/80-R24 162A8 PCL	4	835				
			1990				
			1740				
			4645				
MICHELIN	460/70-R24 159A8 BIB	3	835				
			1990				
			1740				
			4645				

MT 1135 75D ST5 S1

		PRESSURE (bar)	LOAD PER TIRE (kg)			
			FRONT UNLADEN	FRONT (LADEN)	REAR (UNLADEN)	REAR (LADEN)
APOLLO	400/80-R24 20PR 162A8 TL FX525	5	2275	5450	1910	505
ALLIANCE	400/80-R24 162A8 A325	4,5				
ALLIANCE	460/70-R24 A585	4				
MICHELIN	400/80-R24 162A8 PCL	4,2				
MICHELIN	460/70-R24 159A8 BIB	3,7				

		PRESSURE (bar)	LOAD (kg)	GROUND CONTACT PRESSURE (kg/cm ²)		GROUND CONTACT AREA (cm ²)	
				HARD GROUND	SOFT GROUND	HARD GROUND	SOFT GROUND
APOLLO	400/80-R24 20PR 162A8 TL FX525	5	505				
			2115				
			2515				
			5450				
ALLIANCE	400/80-R24 162A8 A325	4,5	935				
			2115				
			2515				
			5450				
ALLIANCE	460/70-R24 A585	4	935				
			2115				
			2515				
			5450				
MICHELIN	400/80-R24 162A8 PCL	4,2	935				
			2115				
			2515				
			5450				
MICHELIN	460/70-R24 159A8 BIB	3,7	935				
			2115				
			2515				
			5450				

MT 1335 75D ST5 S1

		PRESSURE (bar)	LOAD PER TIRE (kg)			
			FRONT UNLADEN	FRONT (LADEN)	REAR (UNLADEN)	REAR (LADEN)
APOLLO	400/80-R24 20PR 162A8 TL FX525	5	2115	5450	2515	935
ALLIANCE	400/80-R24 162A8 A325	4,5				
ALLIANCE	460/70-R24 A585	4				
MICHELIN	400/80-R24 162A8 PCL	4,2				
MICHELIN	460/70-R24 159A8 BIB	3,7				

		PRESSURE (bar)	LOAD (kg)	GROUND CONTACT PRESSURE (kg/cm ²)		GROUND CONTACT AREA (cm ²)	
				HARD GROUND	SOFT GROUND	HARD GROUND	SOFT GROUND
APOLLO	400/80-R24 20PR 162A8 TL FX525	5	935				
			2115				
			2515				
			5450				
ALLIANCE	400/80-R24 162A8 A325	4,5	935				
			2115				
			2515				
			5450				
ALLIANCE	460/70-R24 A585	4	935				
			2115				
			2515				
			5450				
MICHELIN	400/80-R24 162A8 PCL	4,2	935				
			2115				
			2515				
			5450				
MICHELIN	460/70-R24 159A8 BIB	3,7	935				
			2115				
			2515				
			5450				

MT 1335 100D ST5 S2

		PRESSURE (bar)	LOAD PER TIRE (kg)			
			FRONT UNLADEN	FRONT (LADEN)	REAR (UNLADEN)	REAR (LADEN)
APOLLO	400/80-R24 20PR 162A8 TL FX525	5	2155	5485	2555	975
ALLIANCE	400/80-R24 162A8 A325	4,5				
ALLIANCE	460/70-R24 A585	4				
MICHELIN	400/80-R24 162A8 PCL	4,2				
MICHELIN	460/70-R24 159A8 BIB	3,7				

		PRESSURE (bar)	LOAD (kg)	GROUND CONTACT PRESSURE (kg/cm2)		GROUND CONTACT AREA (cm2)	
				HARD GROUND	SOFT GROUND	HARD GROUND	SOFT GROUND
APOLLO	400/80-R24 20PR 162A8 TL FX525	5	975				
			2155				
			2555				
			5485				
ALLIANCE	400/80-R24 162A8 A325	4,5	975				
			2155				
			2555				
			5485				
ALLIANCE	460/70-R24 A585	4	975				
			2155				
			2555				
			5485				
MICHELIN	400/80-R24 162A8 PCL	4,2	975				
			2155				
			2555				
			5485				
MICHELIN	460/70-R24 159A8 BIB	3,7	975				
			2155				
			2555				
			5485				

DIMENSIONS

MT 735 75D ST5 S1

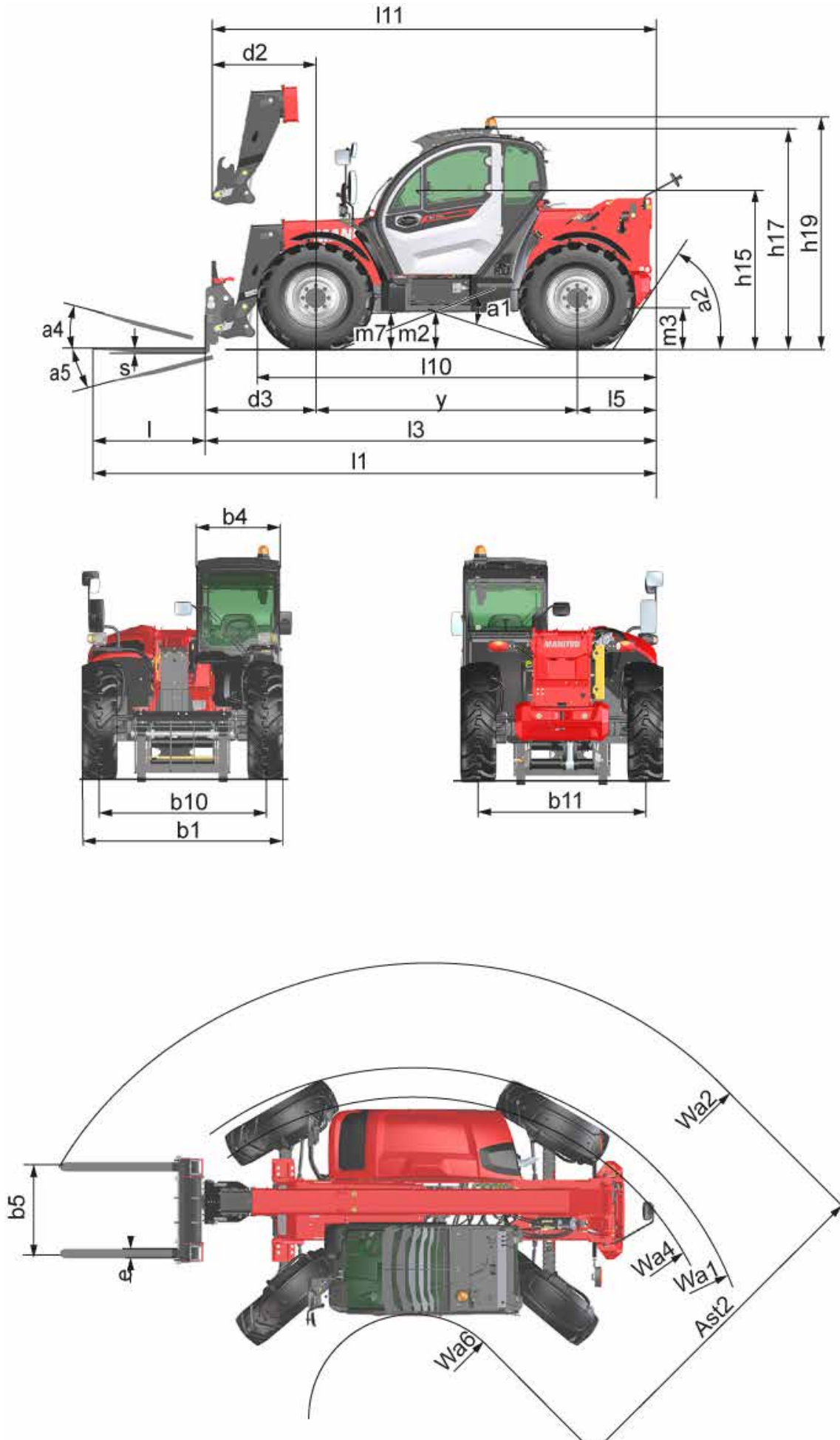

MACHINE LENGTH	l1	mm	5985
	l3	mm	4785
	l5	mm	800
	l10	mm	4230
	l11	mm	4707
MACHINE WIDTH	b1	mm	2260
	b4	mm	950
	b5	mm	1022
	b10	mm	1870
	b11	mm	1870
MACHINE HEIGHT	h15	mm	1774-1820
	h17	mm	2488
	h19	mm	2619
DISTANCE	d2	mm	1107
	d3	mm	1185
AISLE WIDTH	Ast2	mm	3480
ATTACHMENT	l	mm	1200
	s	mm	50
	e	mm	100
TURNING RADIUS	Wa1	mm	3775
	Wa2	mm	4750
	Wa6	mm	1270
GROUND CLEARANCE	m2	mm	425
	m3	mm	450
	m7	mm	450
ANGLE	a1	°	36,6
	a2	°	58
	a4	°	13
	a5	°	114
WHEELBASE	y	mm	2800

DIMENSIONS

MT 935 75D ST5 S1

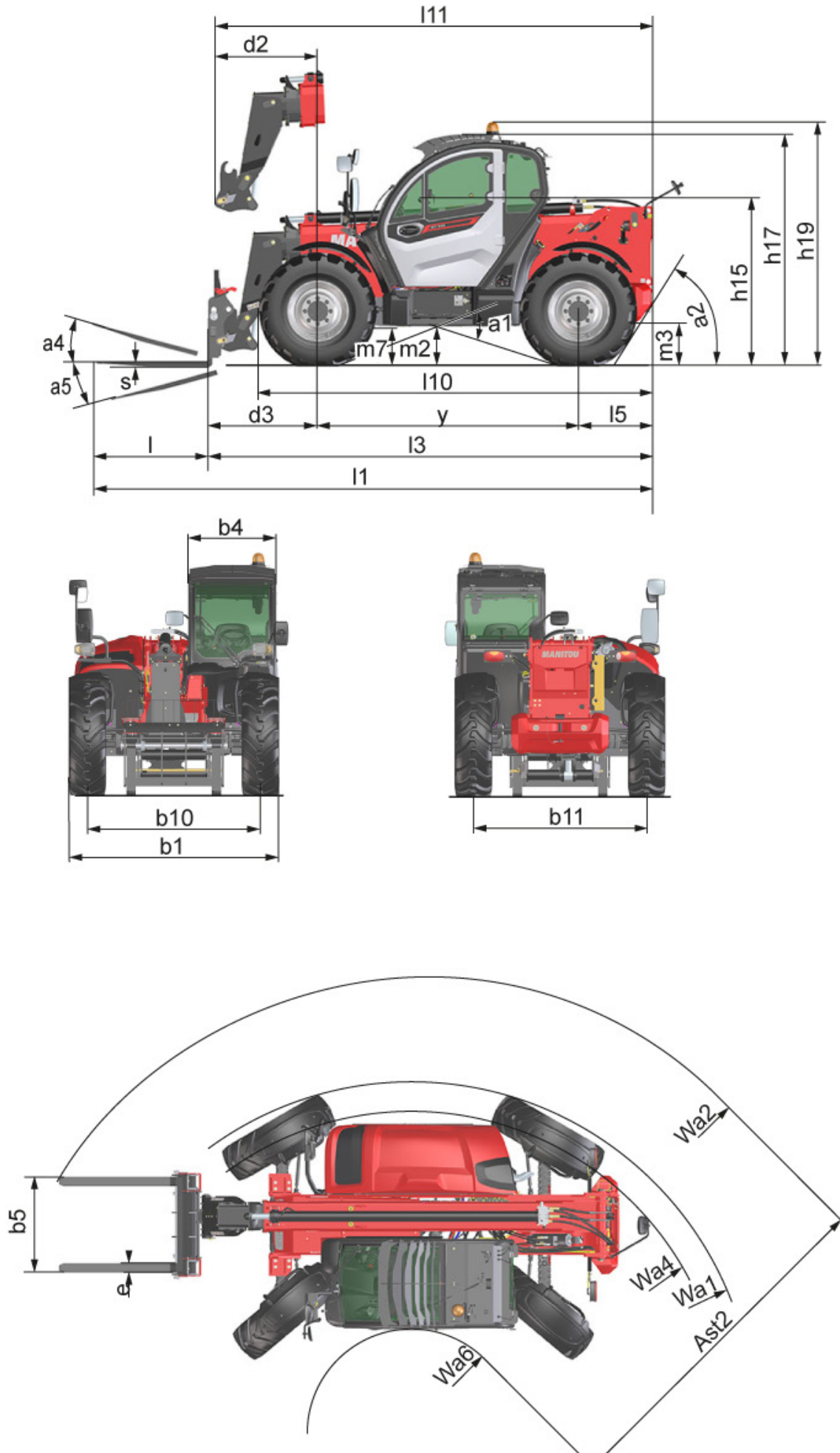

MACHINE LENGTH	l1	mm	5981
	l3	mm	4781
	l5	mm	800
	l10	mm	4230
	l11	mm	4703
MACHINE WIDTH	b1	mm	2260
	b4	mm	950
	b5	mm	1022
	b10	mm	1870
	b11	mm	1870
MACHINE HEIGHT	h15	mm	1774-1820
	h17	mm	2488
	h19	mm	2619
DISTANCE	d2	mm	1103
	d3	mm	1181
AISLE WIDTH	Ast2	mm	3470
ATTACHMENT	l	mm	1200
	s	mm	50
	e	mm	100
TURNING RADIUS	Wa1	mm	3775
	Wa2	mm	4740
	Wa6	mm	1270
GROUND CLEARANCE	m2	mm	425
	m3	mm	450
	m7	mm	450
ANGLE	a1	°	36,6
	a2	°	58
	a4	°	13
	a5	°	114
WHEELBASE	y	mm	2800

DIMENSIONS

MT 1135 75D ST5 S1

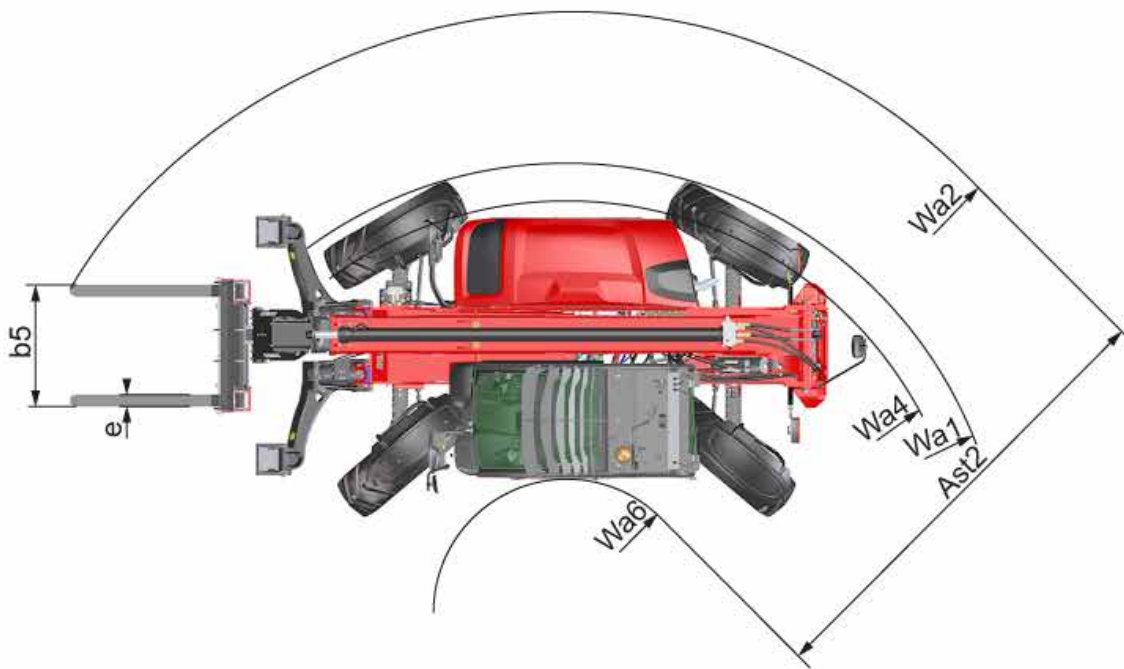
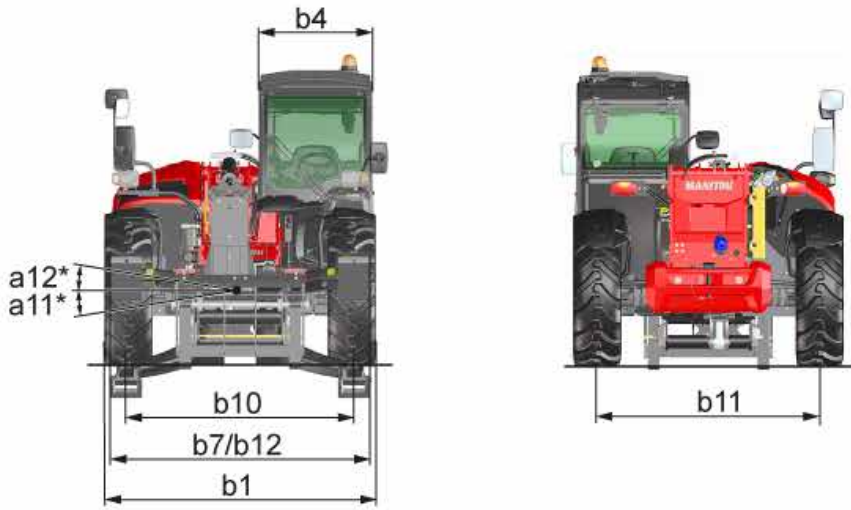
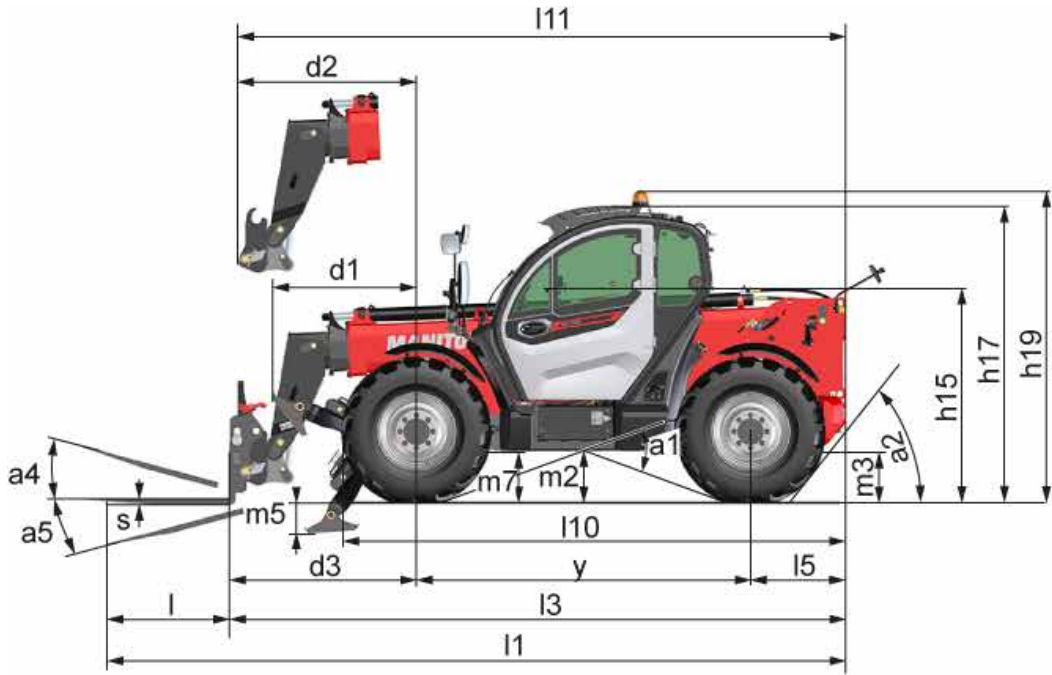

MACHINE LENGTH	l1	mm	6345
	l3	mm	5145
	l5	mm	800
	l10	mm	4230
	l11	mm	5295
MACHINE WIDTH	b1	mm	2260
	b4	mm	950
	b5	mm	1022
	b10	mm	1870
	b11	mm	1870
MACHINE HEIGHT	h15	mm	1774-1820
	h17	mm	2488
	h19	mm	2619
DISTANCE	d1	mm	1215
	d2	mm	1695
	d3	mm	1545
AISLE WIDTH	Ast2	mm	3960
ATTACHMENT	l	mm	1200
	s	mm	50
	e	mm	100
TURNING RADIUS	Wa1	mm	3775
	Wa2	mm	5230
	Wa6	mm	1270
GROUND CLEARANCE	m2	mm	425
	m3	mm	450
	m5	mm	220
	m7	mm	450
ANGLE	a1	°	36,6
	a2	°	31
	a4	°	13
	a5	°	114
	a11	°	7
	a12	°	7
WHEELBASE	y	mm	2800

DIMENSIONS

MT 1335 75D ST5 S1 MT 1335 100D ST5 S2

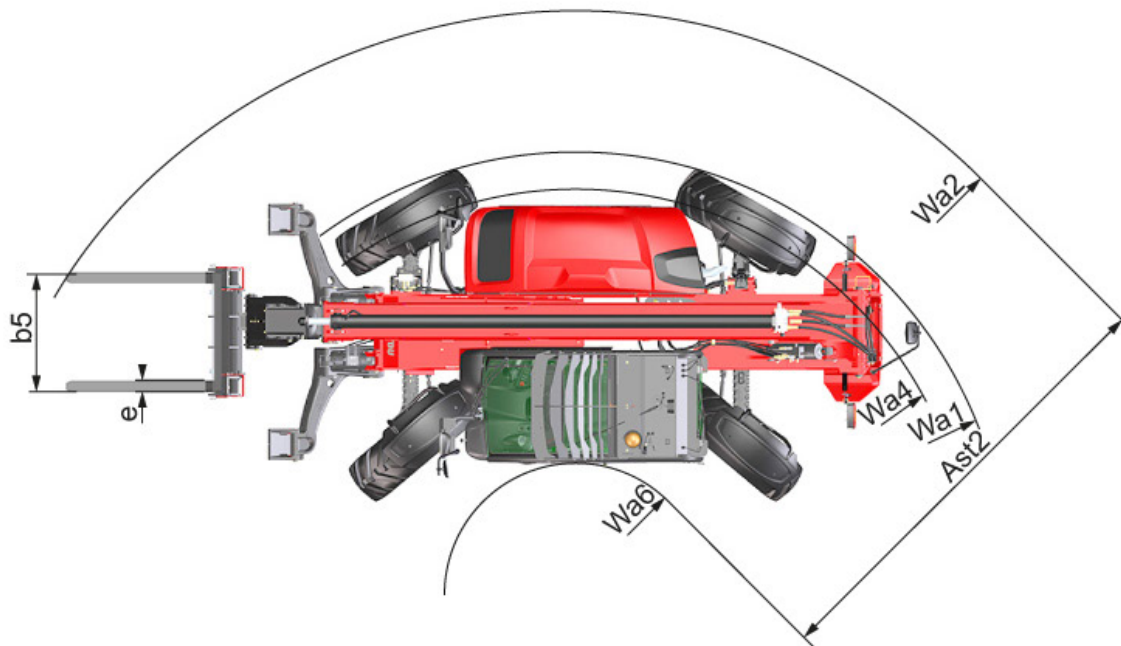
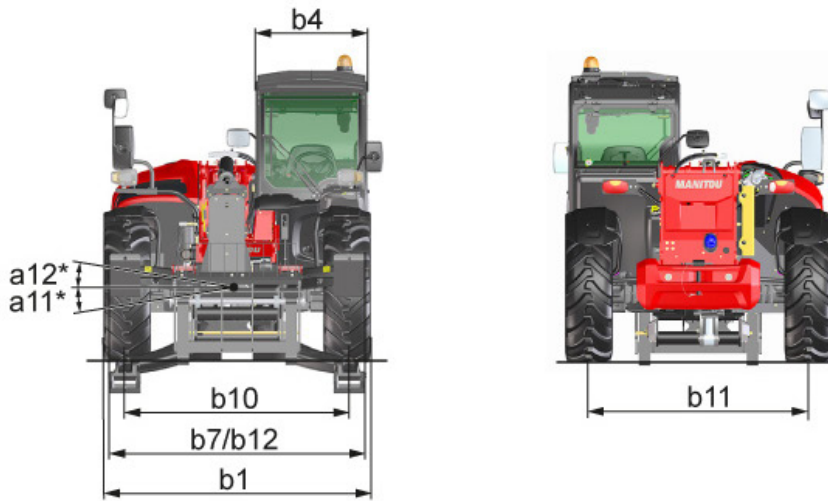
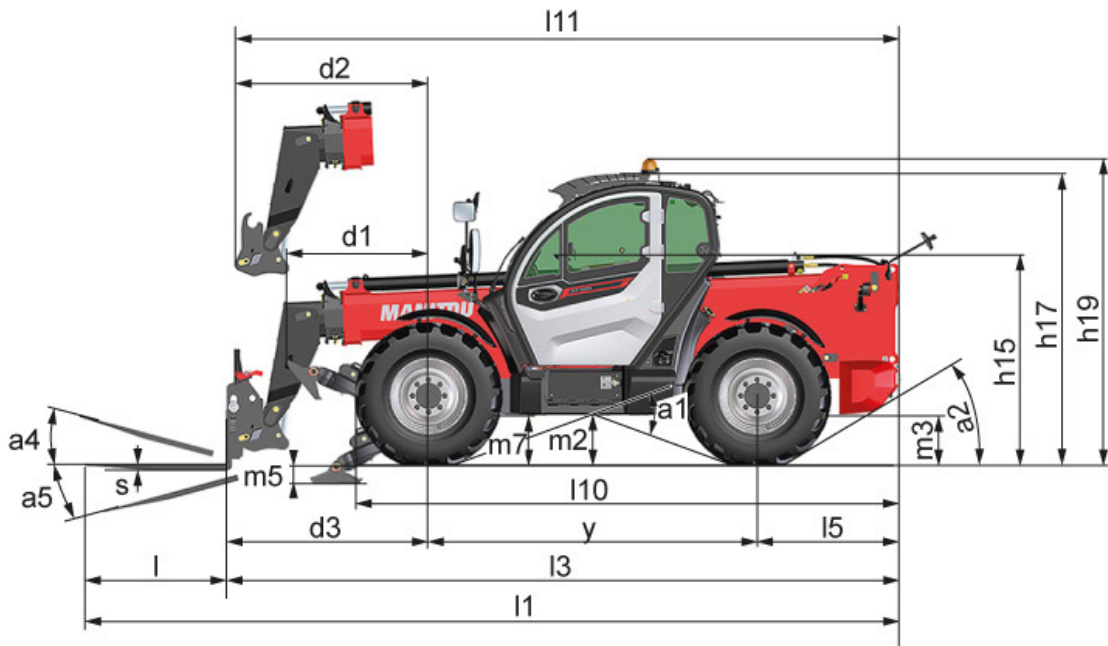

MACHINE LENGTH	l1	mm	6925
	l3	mm	5725
	l5	mm	1200
	l10	mm	4630
	l11	mm	5695
MACHINE WIDTH	b1	mm	2260
	b4	mm	950
	b5	mm	1022
	b10	mm	1870
	b11	mm	1870
MACHINE HEIGHT	h15	mm	1774-1820
	h17	mm	2488
	h19	mm	2619
DISTANCE	d1	mm	1215
	d2	mm	1695
	d3	mm	1725
AISLE WIDTH	Ast2	mm	3960
ATTACHMENT	l	mm	1200
	s	mm	50
	e	mm	100
TURNING RADIUS	Wa1	mm	3775
	Wa2	mm	5230
	Wa6	mm	1270
GROUND CLEARANCE	m2	mm	425
	m3	mm	450
	m5	mm	220
	m7	mm	450
ANGLE	a1	°	36,6
	a2	°	31
	a4	°	13
	a5	°	114
	a11	°	7
	a12	°	7
WHEELBASE	y	mm	2800

STANDARD WITH TIRES "A"

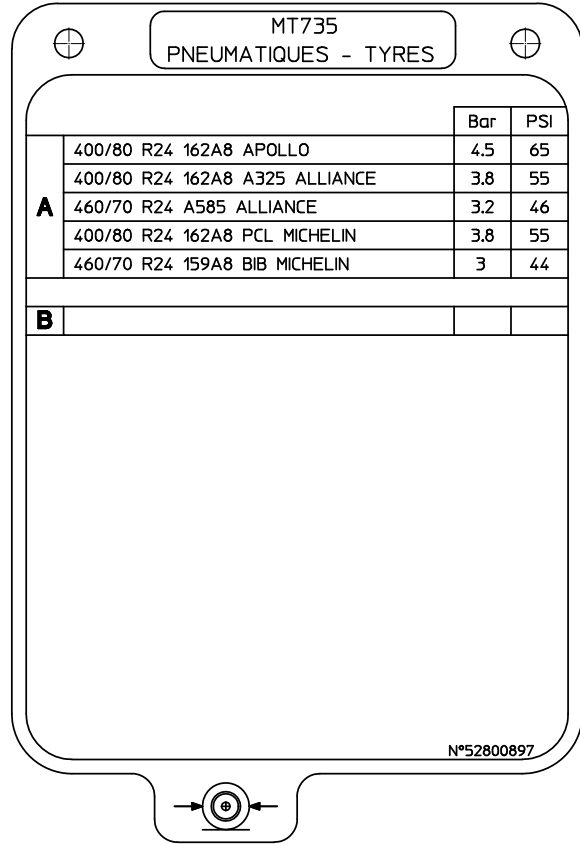
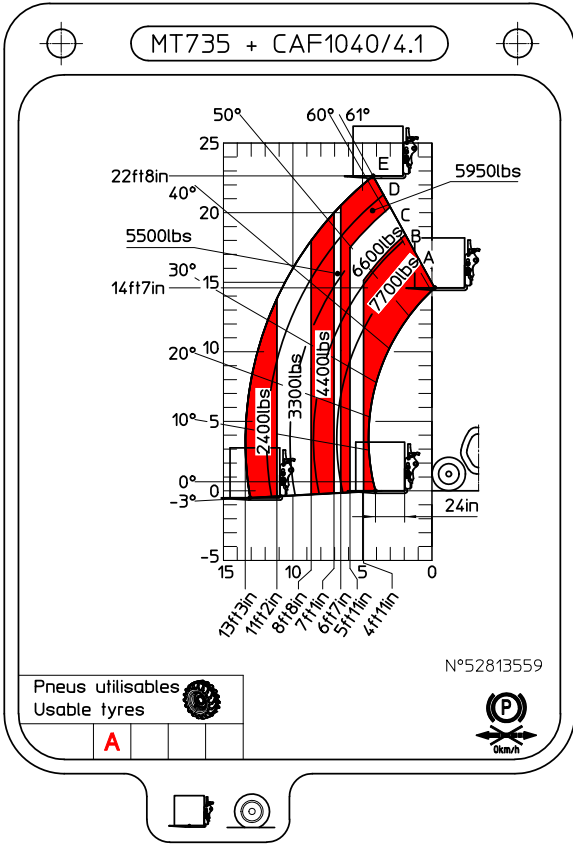

STANDARD WITH TIRES "A"

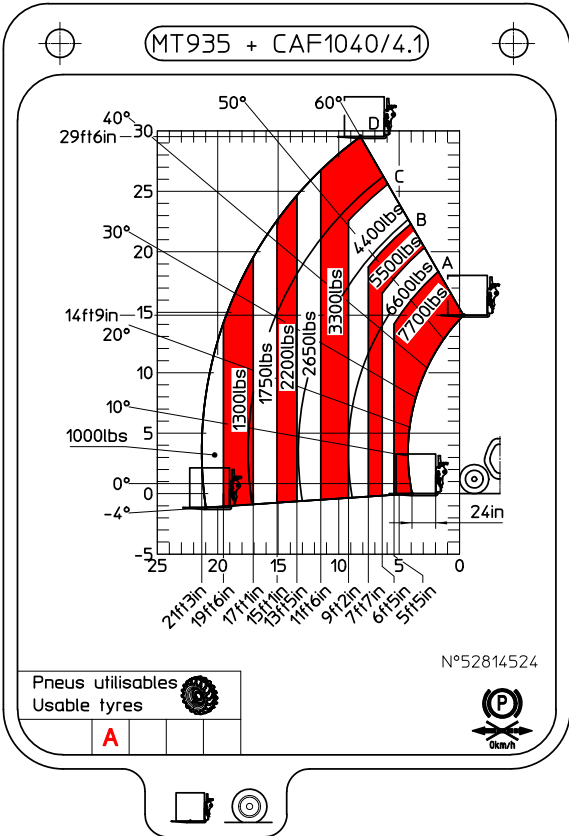

MT935 PNEUMATIQUES - TYRES

	Bar	PSI
A 400/80 R24 162A8 APOLLO	5	73
400/80 R24 162A8 A325 ALLIANCE	4	58
400/80 R24 162A8 PCL MICHELIN	4	58
460/70 R24 A585 ALLIANCE	3.6	52
B 460/70 R24 159A8 BIB MICHELIN	3	44

N°52842996

STANDARD WITH TIRES "B"

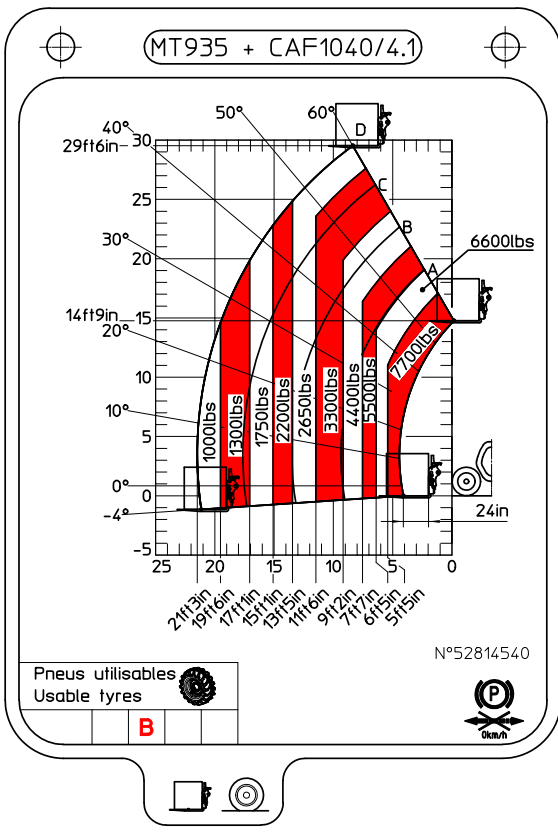

MT935 PNEUMATIQUES - TYRES

	Bar	PSI
A 400/80 R24 162A8 APOLLO	5	73
400/80 R24 162A8 A325 ALLIANCE	4	58
400/80 R24 162A8 PCL MICHELIN	4	58
460/70 R24 A585 ALLIANCE	3.6	52
B 460/70 R24 159A8 BIB MICHELIN	3	44

N°52842996

STANDARD WITH TIRES "A" "B" WITHOUT STABILIZERS

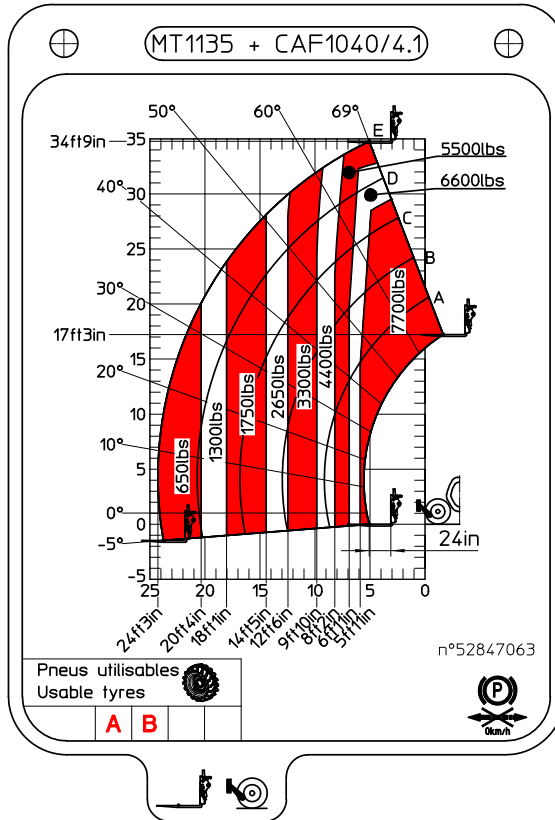

STANDARD WITH TIRES "A" ON STABILIZERS

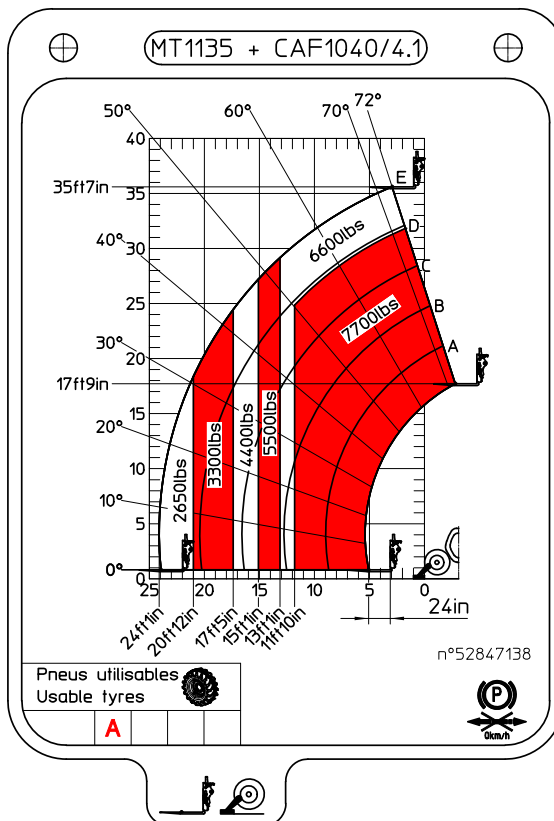

STANDARD WITH TIRES "B" ON STABILIZERS

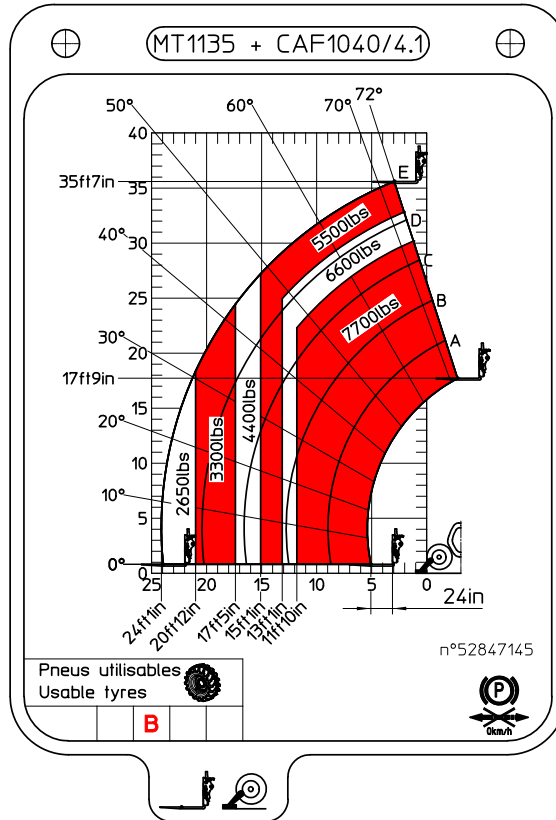

⊕ (MT1135 PNEUMATIQUES - TYRES) ⊕

		Bar	PSI
A	400/80 R24 162A8 APOLLO	5	73
	400/80 R24 162A8 A325 ALLIANCE	4.5	65
	400/80 R24 162A8 PCL MICHELIN	4.2	61
	460/70 R24 A585 ALLIANCE	4	58
B	460/70 R24 159A8 BIB MICHELIN	3.7	54

N°52846970

⊕ ⊕

STANDARD WITH TIRES "A" WITHOUT STABILIZERS

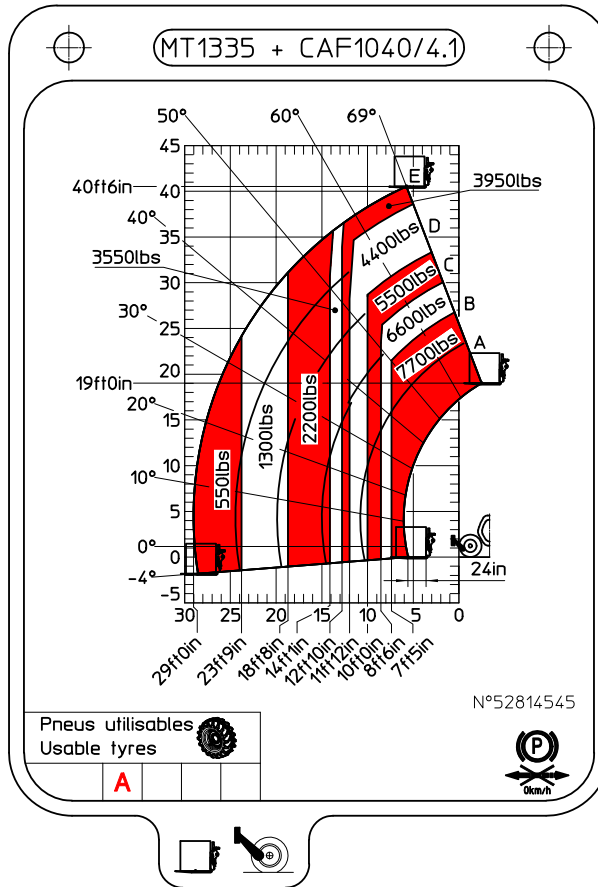

STANDARD WITH TIRES "A" ON STABILIZERS

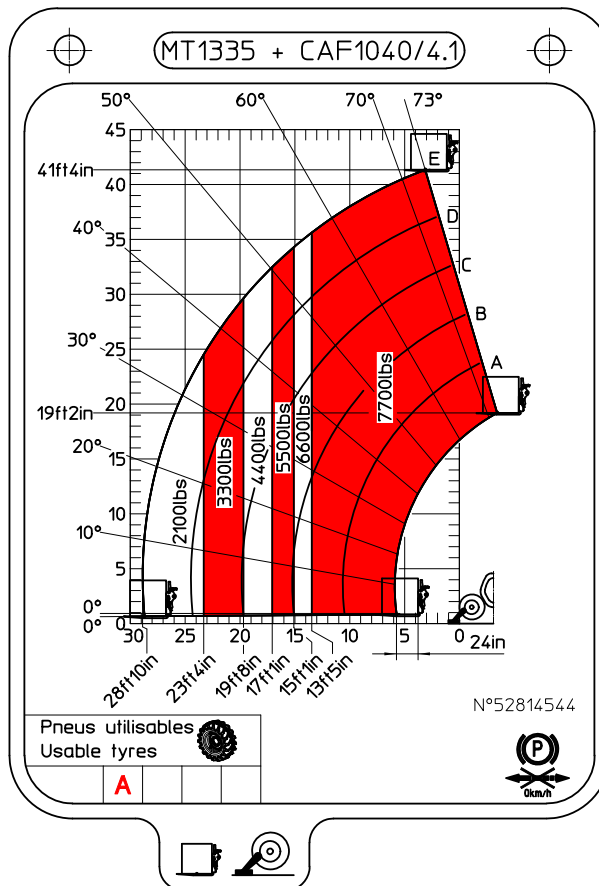

⊕
MT1335
⊕

PNEUMATIQUES - TYRES

		Bar	PSI
A	400/80 R24 162A8 APOLLO	5	73
	400/80 R24 162A8 A325 ALLIANCE	4.5	65
	460/70 R24 A585 ALLIANCE	4	58
	400/80 R24 162A8 PCL MICHELIN	4.2	61
	460/70 R24 159A8 BIB MICHELIN	3.7	54
B			

N°52800900

We use European standard EN15830 relating to operator visibility.

- Adhere to the instructions for optimizing operator visibility in the immediate vicinity (≤ 1 - OPERATING AND SAFETY INSTRUCTIONS: OPERATOR INSTRUCTIONS: OPERATING INSTRUCTIONS WITH AND WITHOUT LOAD: D - VISIBILITY).

DESCRIPTION AND ADJUSTMENT OF REAR-VIEW MIRRORS

- 1 - LEFT REAR-VIEW MIRROR
- 2 - MAIN RIGHT REAR-VIEW MIRROR
- 3 - SECONDARY RIGHT REAR-VIEW MIRROR
- 4 - RIGHT REAR-VIEW MIRROR
- 5 - INSIDE REAR-VIEW MIRROR (OPTION)
- 6 - REAR-VIEW MIRROR

- Place the machine on level ground with the engine stopped, and the boom retracted and lowered as far as possible.
- Note the position of the reference points ●●●○ in the illustrations, to see and correctly adjust the rear-view mirrors.

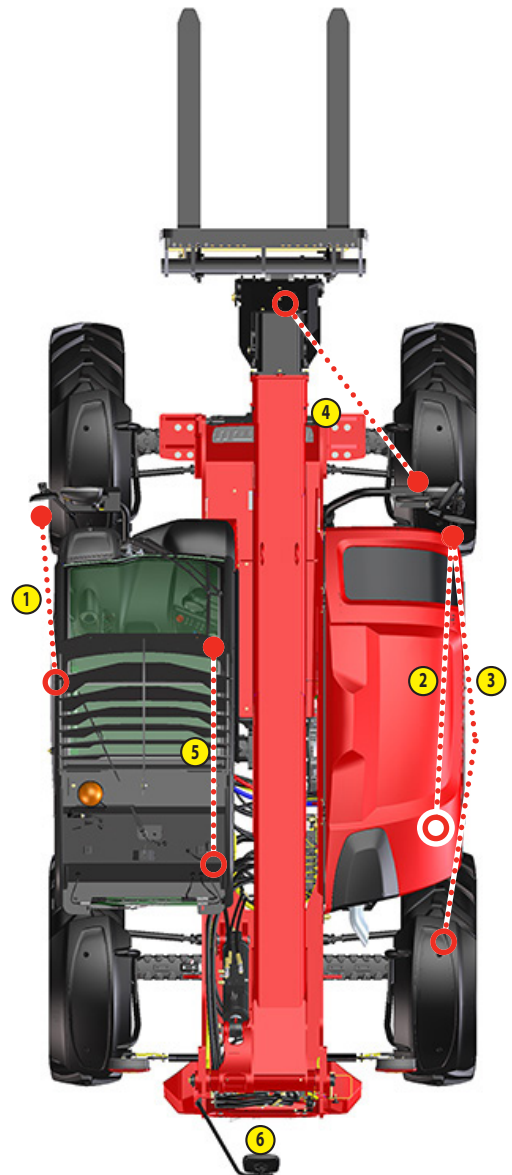
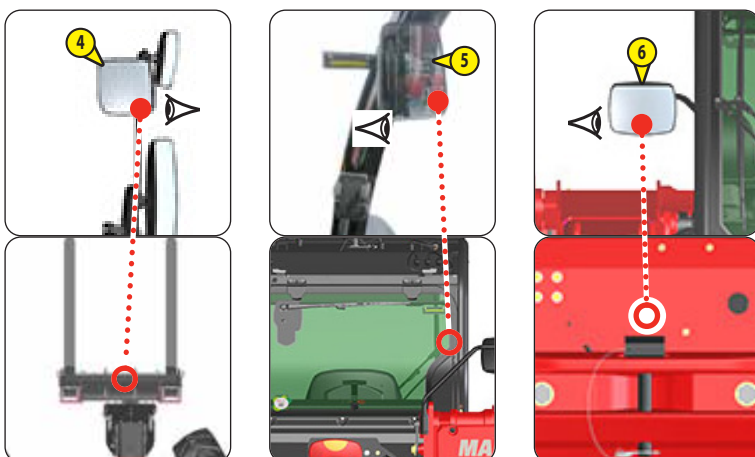

We use European standard EN15830 relating to operator visibility.

- Adhere to the instructions for optimizing operator visibility in the immediate vicinity (≤ 1 - OPERATING AND SAFETY INSTRUCTIONS: OPERATOR INSTRUCTIONS: OPERATING INSTRUCTIONS WITH AND WITHOUT LOAD: D - VISIBILITY).

DESCRIPTION AND ADJUSTMENT OF REAR-VIEW MIRRORS

- 1 - LEFT REAR-VIEW MIRROR
- 2 - MAIN RIGHT REAR-VIEW MIRROR
- 3 - SECONDARY RIGHT REAR-VIEW MIRROR
- 4 - RIGHT REAR-VIEW MIRROR
- 5 - INSIDE REAR-VIEW MIRROR (OPTION)
- 6 - REAR-VIEW MIRROR

- Place the machine on level ground with the engine stopped, and the boom retracted and lowered as far as possible.
- Note the position of the reference points ●●○ in the illustrations, to see and correctly adjust the rear-view mirrors.

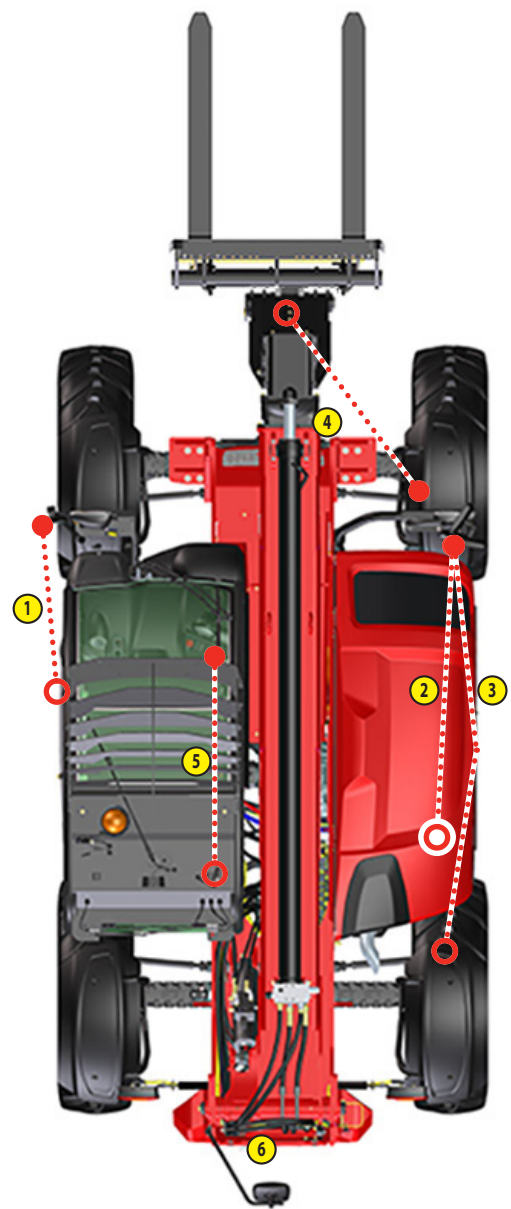
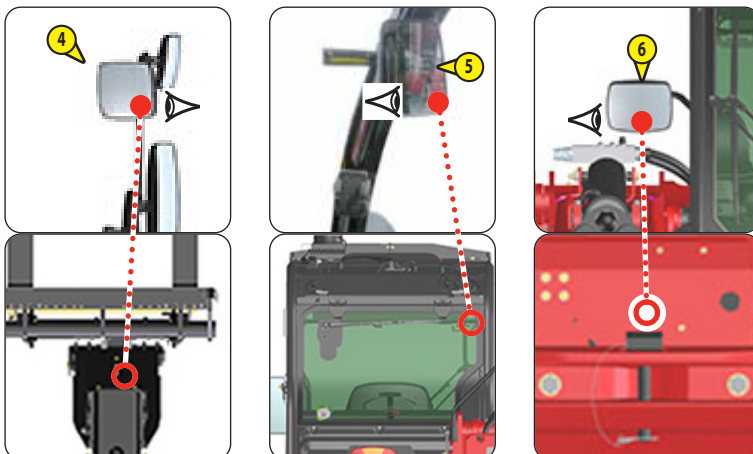
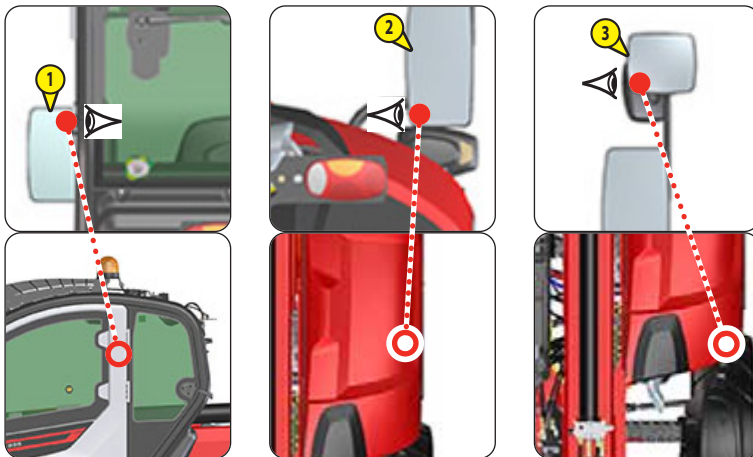
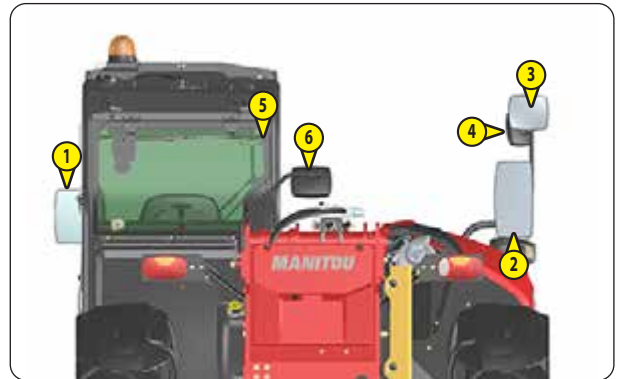

We use European standard EN15830 with regard to operator visibility.

- Adhere to the instructions for optimizing operator visibility in the immediate vicinity (≠ 1 - IOPERATING AND SAFETY INSTRUCTIONS: OPERATOR INSTRUCTIONS: OPERATING INSTRUCTIONS WITH AND WITHOUT LOAD: D - VISIBILITY).

DESCRIPTION AND ADJUSTMENT OF REAR-VIEW MIRRORS

- 1 - LEFT REAR-VIEW MIRROR
- 2 - MAIN RIGHT REAR-VIEW MIRROR
- 3 - SECONDARY RIGHT REAR-VIEW MIRROR
- 4 - RIGHT REAR-VIEW MIRROR
- 5 - INSIDE REAR-VIEW MIRROR (OPTION)
- 6 - REAR-VIEW MIRROR

- Place the machine on level ground with the engine stopped, and the boom retracted and lowered as far as possible.
- Note the position of the reference points ●...○ in the illustrations, to see and correctly adjust the rear-view mirrors.

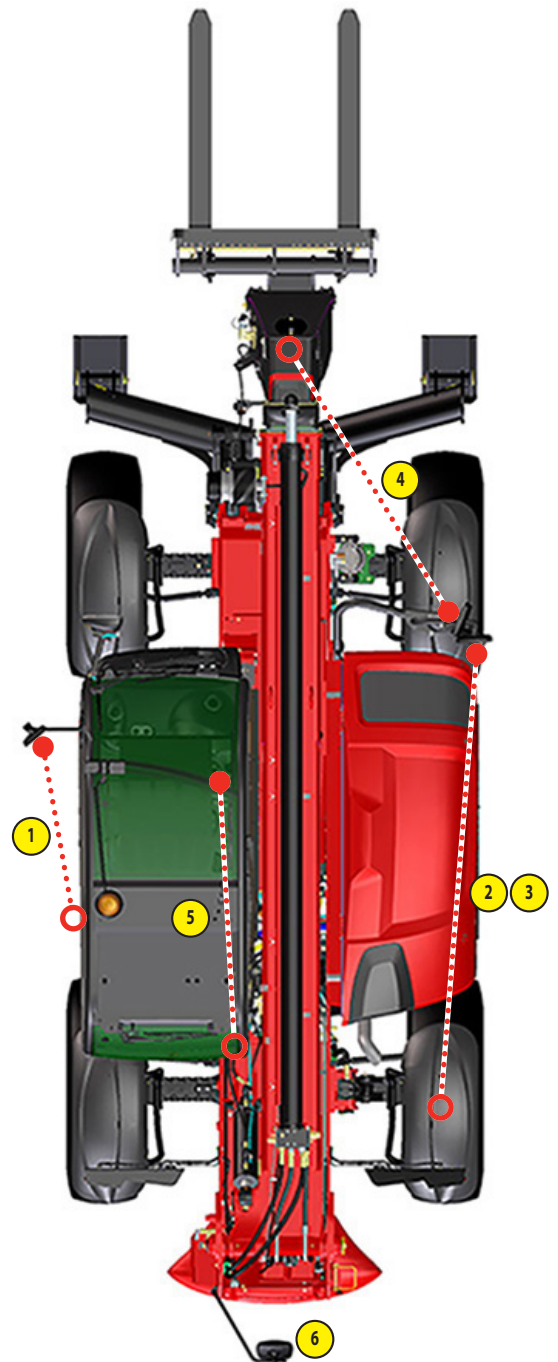
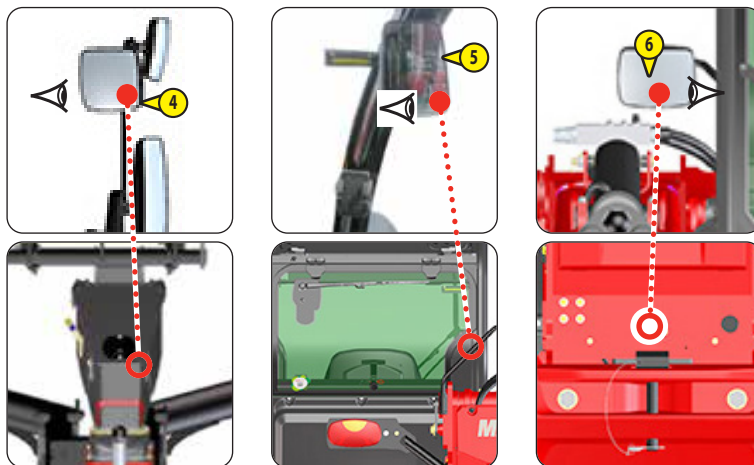
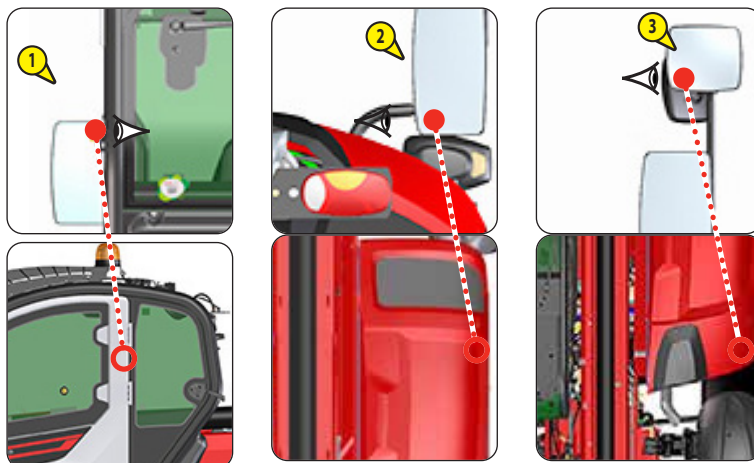

We use European standard EN15830 with regard to operator visibility.

- Adhere to the instructions for optimizing operator visibility in the immediate vicinity (≪ 1 - IOPERATING AND SAFETY INSTRUCTIONS: OPERATOR INSTRUCTIONS: OPERATING INSTRUCTIONS WITH AND WITHOUT LOAD: D - VISIBILITY).

DESCRIPTION AND ADJUSTMENT OF REAR-VIEW MIRRORS

- 1 - LEFT REAR-VIEW MIRROR
- 2 - MAIN RIGHT REAR-VIEW MIRROR
- 3 - SECONDARY RIGHT REAR-VIEW MIRROR
- 4 - RIGHT REAR-VIEW MIRROR
- 5 - INSIDE REAR-VIEW MIRROR (OPTION)
- 6 - REAR-VIEW MIRROR

- Place the machine on level ground with the engine stopped, and the boom retracted and lowered as far as possible.
- Note the position of the reference points ●...○ in the illustrations, to see and correctly adjust the rear-view mirrors.

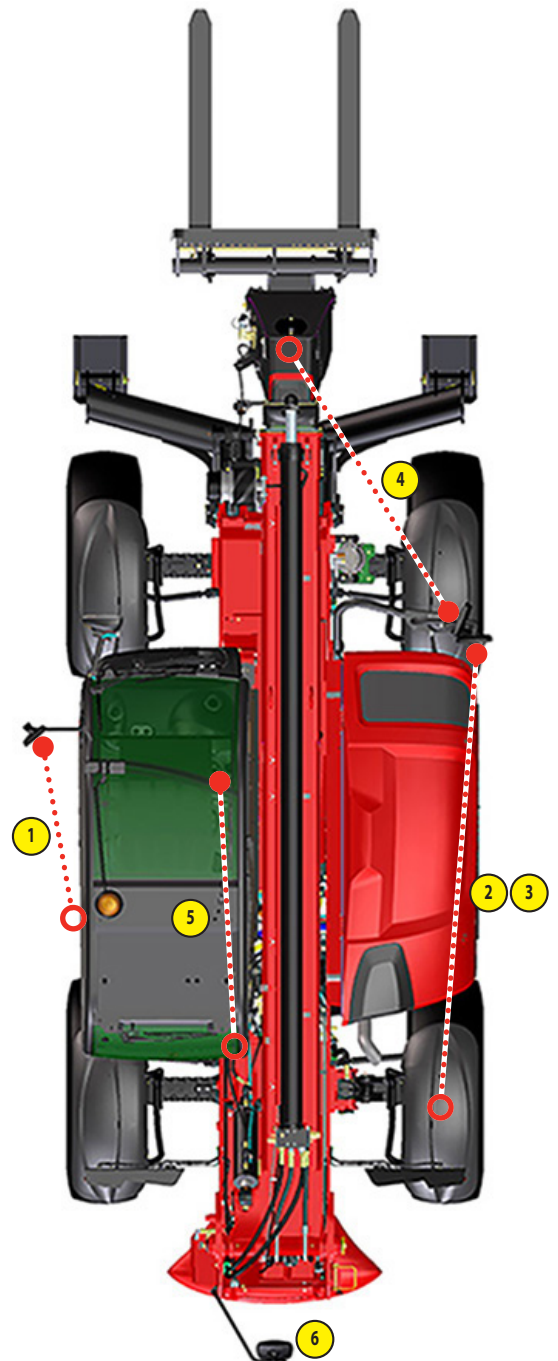
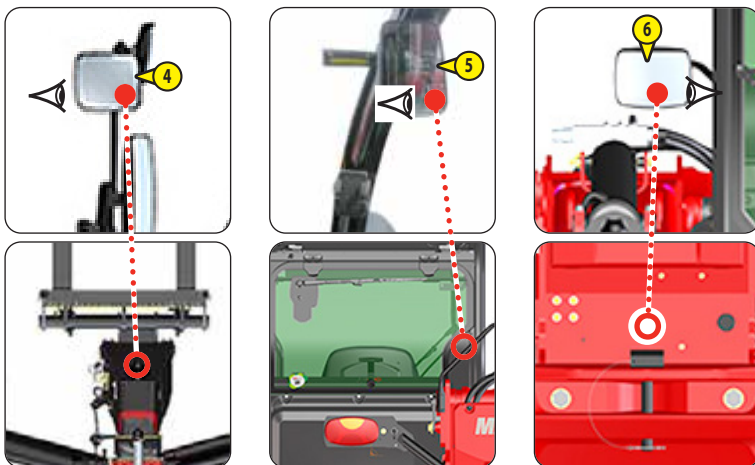
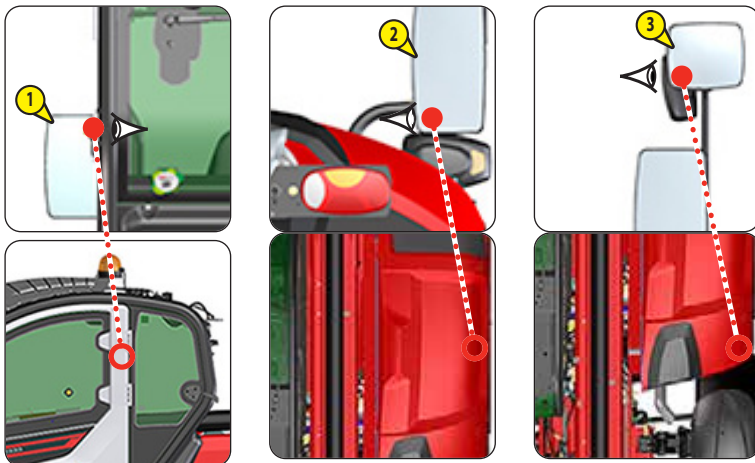
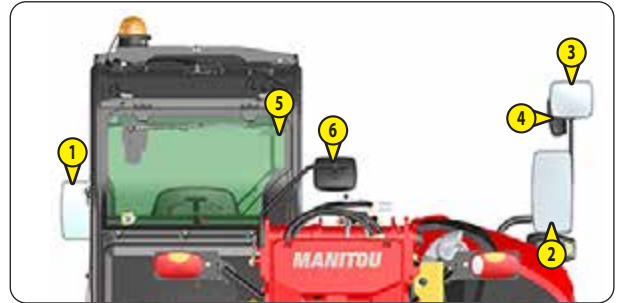

INSTRUMENTS AND CONTROLS

DESCRIPTION

N.B.: All the terms such as: RIGHT, LEFT, FRONT, REAR are as seen by an observer occupying the driver's seat and looking straight ahead.

1 - DRIVER'S CAB ACCESS	2-56
2 - DRIVER'S SEAT	2-56
3 - SEAT BELT	2-57
4 - BATTERY CUT-OFF	2-57
5 - EMERGENCY STOP	2-57
6 - IGNITION SWITCH	2-57
7 - DASHBOARD "HARMONY"	2-58
9 - INFORMATION SCREEN CONTROL BUTTONS	2-62
10 - PUSH BUTTON PANEL	2-63
11 - SWITCHES	2-64
12 - HAZARD WARNING LIGHTS	2-65
13 - LIGHTING, HORN AND INDICATOR SWITCH	2-65
14 - FRONT AND REAR WIPER SWITCH	2-65
15 - 12V SOCKET	2-66
16 - USB RECHARGING SOCKET	2-66
17 - FUSES AND RELAYS IN THE CAB	2-66
18 - FUSES AND RELAYS UNDER THE ENGINE HOOD	2-68
19 - FORWARD/NEUTRAL/REVERSE SELECTOR	2-69
20 - GEAR LEVER AND TRANSMISSION CUT-OFF	2-69
21 - STEERING SELECTION	2-70
22 - ACCELERATOR PEDAL	2-70
23 - SERVICE BRAKE PEDAL AND TRANSMISSION CUT-OFF	2-70
24 - FUNCTION FILES	2-70
25 - HYDRAULIC BOOM CONTROLS	2-71
26 - STABILIZER CONTROLS	2-71
27 - FRAME LEVELING CONTROLS	2-71
28 - HEATER CONTROL	2-72
29 - AIR CONDITIONING CONTROLS (AIR CONDITIONING OPTION)	2-72
30 - DEMIST VENTS	2-73
31 - HEATING VENTS	2-73
32 - DOOR OPENING AND CLOSING HANDLE	2-73
33 - DOOR WINDOW RELEASE BUTTON	2-73
34 - DOOR WINDOW OPENING AND CLOSING HANDLE	2-73
35 - HANDLE FOR REAR WINDOW OPENING	2-74
36 - DOCUMENT STORAGE NET	2-74
37 - FRONT HEADLIGHTS	2-74
38 - REAR LIGHTS	2-74
39 - ROTATING BEACON LIGHT	2-75
40 - SUN VISOR	2-75
41 - ROOF LIGHT	2-75
42 - COAT HOOK	2-75
43 - INSIDE REAR-VIEW MIRROR (OPTION)	2-75
44 - LEVEL INDICATOR	2-75
45 - STEERING WHEEL ADJUSTMENT LEVER (OPTION)	2-75
46 - BOOM SAFETY WEDGE	2-75
47 - FUEL TANK	2-76
48 - TANK "DEF" (Diesel Exhaust Fluid)	2-76
49 - BATTERY CASING	2-76

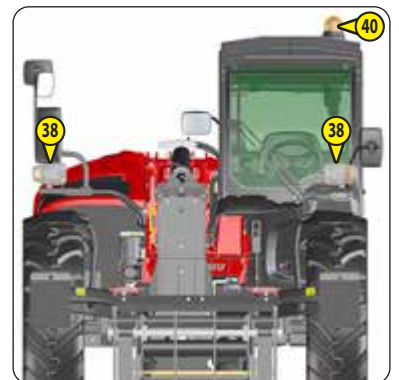
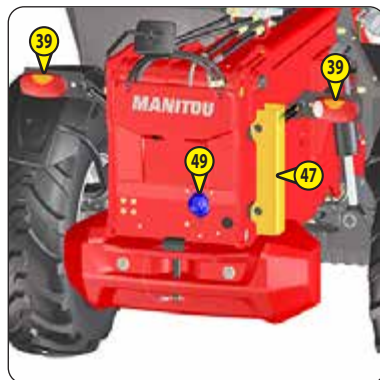
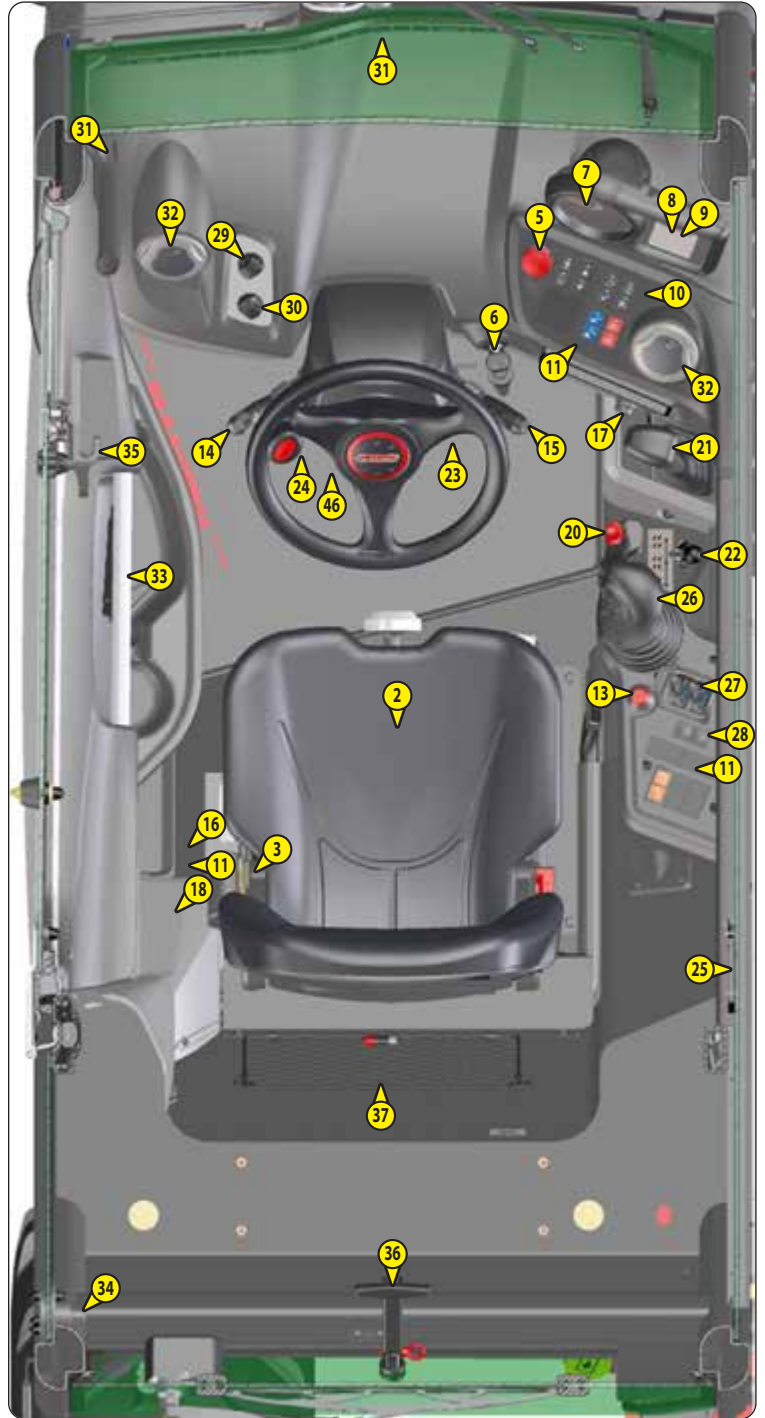
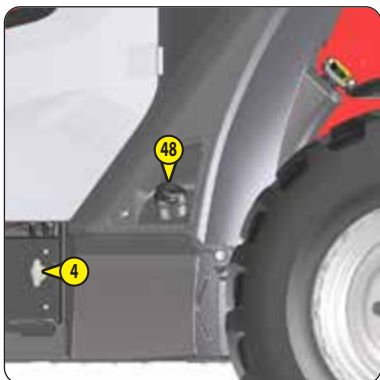
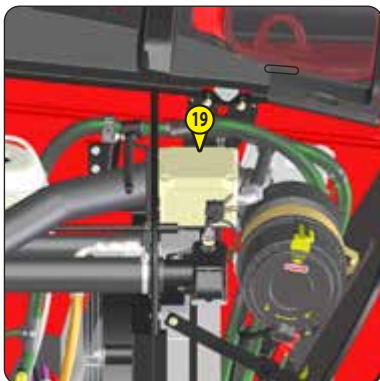

EMERGENCY BRAKE

SERVICE BRAKE

If the service brake is not working properly:

- Press down fully on the service brake pedal to immobilize the machine.
- Activate the hand-operated parking brake.



HAND-OPERATED PARKING BRAKE

⚠ IMPORTANT ⚠

Beware of sudden immobilization of the machine

In the event of immediate danger:

- Activate the hand-operated parking brake.



EMERGENCY EXIT

REAR WINDOW

Use the rear window as an emergency exit, if it is impossible to leave the cab by the door;

- Remove the pin to fully open the rear window.



1 - DRIVER'S CAB ACCESS

Use the contact points 1 to get into or out of the driver's cab.

- Mounting at the front.
- Descending at the rear.



2 - DRIVER'S SEAT

For increased comfort, adjust the seat to your requirements and adopt the correct position in the driver's cab.

⚠ IMPORTANT ⚠

Under no circumstances must the seat be adjusted while the machine is moving.

MAINTENANCE

⚠ IMPORTANT ⚠

*A moving backrest increases the risk of an accident!
Do not clean the driver's seat with a high pressure cleaner.*

Dirt may adversely affect the correct functioning of the seat. For this reason, make sure your seat is always clean.

- It is not necessary to remove the cushions from the seat frame to wash them.
- Avoid wetting the cushion fabric when cleaning it. First check the resistance of the fabric on a small concealed area before using any fabric and plastic cleaner.

FABRIC UPHOLSTERED "MECHANICAL" DRIVER'S SEAT

WEIGHT ADJUSTMENT

- Sit on the seat.
- Turn button 1 to adjust according to the operator's weight.

BACKREST ANGLE ADJUSTMENT

⚠ IMPORTANT ⚠

If you do not support the backrest when making adjustments, it swings completely forward.

- Support the backrest, pull the lever 2 and tilt the backrest to the desired position.

LONGITUDINAL ADJUSTMENT

- Engage the locking lever 3 in the desired position.

Once locked, you can no longer move the seat into another position.



3 - SEAT BELT

⚠ IMPORTANT ⚠

*Under no circumstances must the machine be used if the seat belt is defective (fixing, locking, cuts, tears, etc.).
Immediately repair or replace the seat belt.*

- Sit correctly on the seat.
- Check that the seat belt is not twisted.
- Place the seat belt at hip level.
- Attach the seat belt and check that it locks.
- Adjust the seat belt to your body shape without compressing your pelvis and without excessive slack.



4 - BATTERY CUT-OFF

Enables the battery to be quickly cut off when stopping use of the machine, as a preventive measure after parking, if work is being done on the electrical system or in an emergency to isolate a short-circuit.

⚠ IMPORTANT ⚠

Except in an emergency (fire, accident, overturning of the machine), never operate the battery cut-off with the engine running as this could damage the alternator and the machine's electronic components.

- Switch off the ignition with the key, wait 30 seconds, then operate the battery cut-off.

MT 13 100D ...

N.B.: Wait 5 minutes before disconnecting the battery, this is required in order to purge the Diesel Exhaust Fluid (DEF) system.



5 - EMERGENCY STOP

In the event of danger, it enables the engine to be shut down, thereby cutting-off all hydraulic movements.

⚠ IMPORTANT ⚠

*Be ready for hydraulic movements suddenly stopping when you press this button.
Caution when traveling, sudden stopping of the machine by engagement of the parking brake.
If possible stop the machine before using the emergency stop button.*

- Turn the knob to deactivate it before restarting the machine.



6 - IGNITION SWITCH

This key switch has 5 positions:

- P - Not used.
- O - Ignition cut-off and engine stop.
- I - Ignition + preheat.
- II - Not used.
- III - Start-up and return to I position as soon as the key is released.



7 - DASHBOARD "HARMONY"

INSTRUMENTS AND INDICATORS

A - TACHOMETER

B - ENGINE WATER TEMPERATURE

If the indicator lamp  comes on when the machine is running, this means that the coolant temperature is high. Stop the engine immediately and look for the cause of the cooling circuit malfunction.

C - FUEL LEVEL

If the  light comes on, your operating time is limited. Refill the fuel tank.

D - NOT USED MT 7/9/11/13 75D ...

D - "DEF" (diesel exhaust fluid) LEVEL MT 13 100D ...

If the indicator lamp  comes on, fill the tank with DEF (diesel exhaust fluid)

 **MAIN BEAM INDICATOR LAMP**

 **LOW BEAM INDICATOR LAMP**

 **TURN SIGNAL INDICATOR LAMP**

 **PARKING BRAKE INDICATOR LAMP**

This indicator lamp comes on when the parking brake is on.

 **BATTERY LOAD FAULT INDICATOR**

If the indicator and the buzzer come on when the machine is running, stop the engine immediately and determine the cause (electric circuit, alternator belt, alternator, etc.).

 **STEERING SYSTEM OIL PRESSURE FAULT INDICATOR**

If the indicator light comes on when the machine is running, stop the engine immediately and determine the cause (possible leak, etc.).

 **WATER IN FUEL PRE-FILTER FAULT INDICATOR**

The indicator light will come on when water is detected in the fuel pre-filter. Stop the machine and carry out the necessary repairs.

 **BRAKE FLUID LEVEL WARNING INDICATOR**

If the indicator lamp and buzzer come on when the machine is running, stop the engine immediately and determine the cause (brake fluid level, possible leak, etc.). If the brake fluid level is abnormal, consult your dealer.

 **ENGINE OIL PRESSURE FAULT INDICATOR**

If the indicator lamp comes on when the machine is in operation, stop the engine immediately and look for the cause (oil level in engine crankcase).

N.B.: After starting the engine, the indicator lamp remains on for a few seconds then goes out when the correct engine oil pressure is reached. The full engine power is then available.





ENGINE PREHEATING INDICATOR

Preheating is necessary. When the machine is switched on, the indicator lamp comes on for 2 seconds and goes off as soon as preheat is ended. Start the machine's engine.



GEARBOX OIL PRESSURE WARNING INDICATOR LAMP

This light comes on when there is an abnormal drop in gearbox pressure. Stop the machine and look for the cause (low oil level in the gearbox, internal leak in the gearbox, etc.).



GEARBOX OIL TEMPERATURE FAULT INDICATOR

This light comes on when the temperature of the gear box oil is abnormally high. In this case, place the forward/reverse selector in neutral and leave the engine to idle for a few minutes. If the light remains on, stop the machine and contact your dealer.

N.B.: Abnormal heating of the oil may be linked to incorrect use of the gear box ratios (\leftarrow GEAR LEVER).



HYDRAULIC RETURN FILTER CLOGGING FAULT INDICATOR

The indicator light and buzzer come on when the hydraulic return oil filter cartridge is clogged. If this indicator lamp comes on and stays on, the cartridge needs replacing. Stop the machine and carry out the necessary repairs (\leftarrow 3 - MAINTENANCE).

N.B.: This lamp may come on when starting the machine, and it should go off when the hydraulic fluid reaches its operating temperature.



ENGINE COOLANT LEVEL FAULT INDICATOR

If the indicator light and buzzer come on when the machine is in operation, stop the engine immediately and determine the cause (coolant level, possible leak, radiator, etc.).



ENGINE STOPPED FAULT INDICATOR

If the indicator lights up or flashes when the machine is in operation, stop the engine immediately and consult your dealer.



AIR FILTER CLOGGING FAULT INDICATOR

The light and the buzzer come on when the air filter cartridge is clogged. Stop the engine and carry out the necessary repairs (\leftarrow 3 - MAINTENANCE).



ENGINE FAULT INDICATOR

If the indicator light comes on or flashes while the machine is in operation, a diagnostic fault has been detected. The machine will operate in reduced mode. Consult your dealer as soon as possible.







EXHAUST DECONTAMINATION SYSTEM FAULT INDICATOR LAMP MT 7/9/11/13 75D ...

The indicator comes on if system is efficiency problem is detected, see your dealer.



"SCR" FAULT INDICATOR LAMP (selective catalytic reduction) MT 13 100D ...

The indicator comes on if the system is above the efficiency threshold or if a diesel exhaust fluid quality problem is detected.





Flashing  indicator lamp +  + audible signal	- Level of "DEF" (diesel exhaust fluid) under 10%. - Fill the tank with "DEF" .
 +  + audible signal	- Consult your dealer as soon as possible.



SOOT LEVEL MT 7/9/11/13 75D ...

If the indicator lamp flashes while the machine is in operation, perform a "STATIONARY MACHINE" EXHAUST REGENERATION ($\triangleleft 3$ - MAINTENANCE: OCCASIONAL MAINTENANCE).

The indicator lamp also comes on when the count (700h => 0h) before next regeneration has elapsed.

Flashing  indicator.	-Perform a "STATIONARY MACHINE" EXHAUST REGENERATION.
Flashing  indicator +  + short audible signal.	-If the machine is under-performing, conduct a "STATIONARY MACHINE" EXHAUST REGENERATION.
Flashing  indicator +  + short audible signal.	<i>If the machine is under-performing, stop the machine and contact your dealer.</i>



CRYSTALLIZATION OR SULFURIZATION LEVEL MT 13 100D ...

If the indicator lamp flashes while the machine is in operation, perform a "STATIONARY MACHINE" EXHAUST REGENERATION ($\triangleleft 3$ - MAINTENANCE: OCCASIONAL MAINTENANCE).

The indicator lamp also comes on when the count (700h => 0h) before next regeneration has elapsed.

INFORMATION SCREEN

 BOOM ANGLE

 MAINTENANCE REQUIRED

 MAINTENANCE REQUIRED + ERROR CODE NUMBER

 HYDRAULIC MOVEMENT NEUTRALIZATION

 NO USED

 STABILIZER POSITION INDICATORS MT 1135/1335 ...

 GEAR RATIO

 BLOCKING REAR AXLE OSCILLATION MT 1335 H 75D ST5 S1 MT 1335 H 100D ST5 S2

 WHEEL STEERING INDICATOR

 CLOCK

 DRIVING

 WORK (OPTION)

 EXTERNAL TEMPERATURE

 HOUR METER

 SPEEDOMETER

 HYDRAULIC FLOW RATE ADJUSTMENT (OPTION)











POP UP

- Blue POP UP: information message.
- Grey POP UP: operating message.
- Orange POP UP: warning message.
- Red POP UP: fault message, consult your dealer.



INFORMATION SCREEN

- Hold down the  or  button to choose.

-  Total hour meter.
-  Partial hour meter.
-  Instantaneous fuel consumption.
-  Average fuel consumption.
-  Fuel autonomy.
-  Tachometer.

8 - ANGULAR SECTOR ON BOOM

The angular sector displays the boom angle, and thus improves the reading of the load charts.





9 - INFORMATION SCREEN CONTROL BUTTONS

N.B.: The content of the "INFORMATION" and "PREFERENCES" menus varies according to the machine equipment.





INFORMATION MENU

- Press the button to display the "INFORMATION" menu
- Press the button  to select from the menus and sub-menus.
- Press knob  to confirm.

REPAIR	>	FAULTS
MAINTENANCE	>	MAINTENANCE RESET
GENERAL	>	IDENTIFICATION
	>	SOFTWARE VERSION
HYDRAULICS	>	OIL LEVEL



PREFERENCES MENU

- Press the button to display the "PREFERENCES" menu
- Press the button  to select from the menus and sub-menus.
- Press knob  to confirm.

SYSTEM	>	DATE AND TIME		
	>	LANGUAGES		
	>	UNITS		
	>	SCREEN		
	>	POP UPS		
	>	DIGICODE (OPTION)		
	>	CAMERAS (OPTION)		
	>	CUSTOMER CODE)		
	>	CONFIGURATION (customer or expert code)	>	PARTIAL HOUR METER RESET
		>	MAINTENANCE HOUR METER RESET	
TRANSMISSION	>	ECO MODE (OPTION)		
	>	MANUAL ACCELERATOR (OPTION)		
	>	TRAILER BRAKE TEST (OPTION)		
HYDRAULICS	>	STABILITY REBALANCING		
	>	STABILITY TEST		
	>	EASY CONNECT SYSTEM (OPTION)		
	>	CONFIGURATION (customer or expert code)	>	OVERRIDE
			>	FORCED OPERATION NO DRIVER
ENGINE	>	REGENERATION		
	>	STOP & START (OPTION)		
	>	FAN DRIVE FAN REVERSAL (OPTION)		
EXPERT (expert code)	>	STABILITY CALIBRATION		
	>	BOOM ANGLE CALIBRATION		
	>	AXLE BLOCKING TEST MT 1335 ...		
	>	PEDAL CALIBRATION INCHING		
	>	CARRIAGE ANGLE CALIBRATION		
	>	DISTRIBUTOR CALIBRATION		
	>	INCLINOMETER CALIBRATION		
	>	EXPERT CODE		



BACK

- Press the button to return to the previous stage.



CONFIRMATION

- Press the button to move on to the next step.



MOVE UP

- Press the button to change menu.



MOVE DOWN

- Press the button to change menu.

10 - PUSH BUTTON PANEL

BUTTON FUNCTIONS

- Red button: Safety.
- Orange button: Transmission / Engine.
- Blue button: Hydraulics.
- Black button: Other.

BUTTON DIAGNOSTICS

- If all buttons are unlit, there is a power supply problem. Contact your dealer.
- If all buttons are flashing, there is a connection problem. Contact your dealer.



HYDRAULIC MOVEMENT NEUTRALIZATION

When driving on the road, it is highly recommended (mandatory in Germany) that you disconnect all hydraulic movement. The indicator lamp and  image on the information screen indicate use.



ROTATING BEACON LIGHT

The indicator lamp indicates it is in use.



AUTOMATIC PARKING BRAKE

The function is used to engage the parking brake when the machine is stopped and to release the parking brake when the machine movement conditions are met.

- Press the  button to activate. The indicator light will come on, showing that it is in use.
- Press the button again to deactivate.



"MANUAL MODE" AUTOMATIC PARKING BRAKE

- Press the  button to activate. The indicator light will come on, showing that it is in use.
- Press the button again to deactivate.



STOP & START (OPTION)

< DESCRIPTION AND USE OF THE OPTIONS



TRANSMISSION CUT-OFF

N.B.: In all cases transmission cut-off can be activated using the gear lever.

USE OF TRANSMISSION CUT-OFF

- Indicator lamp on, transmission is cut off with the service brake pedal and the forward/neutral/reverse gear lever.
 - When loading.
- Indicator lamp off, transmission is cut off with the forward/neutral/reverse gear selector.
 - When driving.
 - For inching and continuous stop/start (delicate handling).





TILT CIRCUIT LOCKING (OPTION)

- Press the button to shut off the tilt circuit hydraulic movements. The indicator lamp indicates it is in use.



ATTACHMENT CIRCUIT LOCKING (OPTION)

- Press the button to shut off the attachment circuit hydraulic movements. The indicator lamp indicates it is in use.



MANUAL OVERRIDE OF ATTACHMENT CIRCUIT (OPTION)

< DESCRIPTION AND USE OF THE OPTIONS



FRAME LEVELING ON LEFT

< FRAME LEVELING CONTROLS



FRAME LEVELING ON RIGHT

< FRAME LEVELING CONTROLS



FAN REVERSAL (OPTION)

< DESCRIPTION AND USE OF THE OPTIONS



EXHAUST REGENERATION

< 3 - MAINTENANCE: OCCASIONAL MAINTENANCE



DISABLING "AGGRAVATING" HYDRAULIC MOVEMENT CUT-OFF

< LONGITUDINAL STABILITY LIMITER AND WARNING DEVICE



11 - SWITCHES

N.B.: The location of the switches may vary depending on the options.



BOOM HEAD WORKLIGHTS (OPTION)



FRONT WORKLIGHTS (OPTION)



FRONT AND REAR WORKLIGHTS (OPTION)



ROOF WINDSHIELD WIPER



SIDE WINDSHIELD WIPER (OPTION)



REAR WINDOW DEFROSTER (OPTION)



REAR FOG LIGHTS



GREEN ROTATING BEACON LIGHT (OPTION)



BOOM ELECTRICAL PREDISPOSITION (OPTION)

< DESCRIPTION AND USE OF THE OPTIONS



12 - HAZARD WARNING LIGHTS



13 - LIGHTING, HORN AND INDICATOR SWITCH

The switch controls the visual and sound alarms.

- A - All lights are off, the turn signals do not flash.
- B - The right-hand turn signals flash.
- C - The left-hand turn signals flash.
- D - The sidelights and rear lights are on.
- E - The dipped beam headlights and rear lights are on.
- F - The main beam headlights and rear lights are on.
- G - Headlight signaling.

Pressing the end of the switch sounds the horn.

N.B.: Positions D - E - F - G can be used without switching on the ignition.



14 - FRONT AND REAR WIPER SWITCH

FRONT WINDSHIELD WIPER

- A - Front windshield wiper off.
- B - Front windshield wiper low speed setting.
- C - Front windshield wiper high speed setting.
- D - Front windshield wiper intermittent operation.
- E - Front windshield wiper pulse driven.

REAR WINDSHIELD WIPER

- F - Rear windshield wiper off.
- G - Rear windshield wiper on.
- H - Rear windshield washer by pressing.

N.B.: These functions will only work when the ignition is switched on.

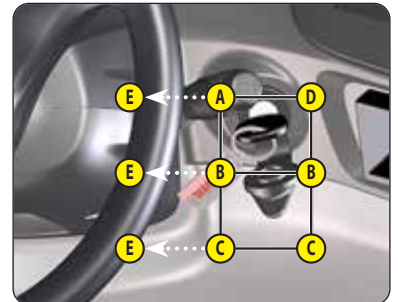

15 - 12V SOCKET

For 12 V appliance and max. amperage 20A.



16 - USB RECHARGING SOCKET



17 - FUSES AND RELAYS IN THE CAB

A sticker on the inside of the access hatch provides a quick view of the use of the electric plate's components described below.

- Remove access panel 1 to gain access to the fuses and relays. Replace a blown fuse with a new fuse of the same quality and rating. Never use a repaired fuse.



F1		Unused.
F2	15 A	Front windshield wiper + washer. Relay (K32).
F3	20 A	Window wind up.
F4	10 A	Rear windshield wiper + windshield washer.
F5	7,5 A	Side windshield wiper + washer (OPTION).
F6	7,5 A	Roof windshield wiper + washer.
F7	7,5 A	Rear axle blocking valve.
F8	5 A	Screen wake.
F9	5 A	Relay (K1).
F10	2 A	Speed sensor.
F11	2 A	JSM joystick.
F12	2 A	Rear camera (OPTION).
F13	5 A	Diagnostics plug.
F14	5 A	Car radio (OPTION).
F15	2 A	Immobilizer (OPTION).
F16	7,5 A	Relay (K34).
F17	15 A	Flashing light unit (K21) + relay (K31).
F18	20 A	Main ECU SPU 40-26.
F19	10 A	Brake lights.
F20	10 A	12 V plug.

F21	10 A	Dual effect rear hydraulic predisposition (OPTION).
F22	15 A	Pneumatic seat (OPTION).
F23	15 A	Front work lights (OPTION). Rear work lights (OPTION).
F24	15 A	Worklights on boom (OPTION).
F25	7,5 A	Boom head solenoid valve (OPTION).
F26	7,5 A	Relay (K4).
F27	7,5 A	Engine ECU wake-up.
F28	2 A	Wheel alignment. Negative brake.
F29	2 A	Boom angular sensor.
F30		
F31	2 A	Stabilizer pressure sensors + elevated position.

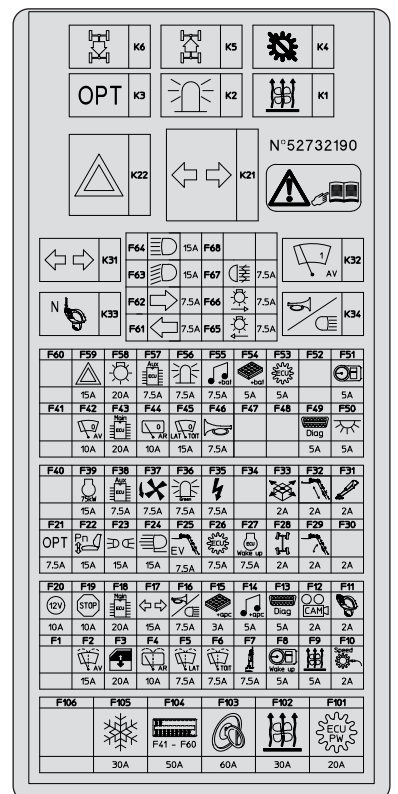

F32	2 A	Boom sensors.
F33		Unused.
F34		Unused.
F35	10 A	Boom electrical predisposition (OPTION).
F36	7,5 A	Green rotating beacon light (OPTION).
F37	7,5 A	Fan reversal (OPTION).
F38	15 A	Auxiliary ECU SPU 40-26 / SPU 25-15.
F39	15 A	Engine ECU wake-up.
F40		Unused.

F41		Unused.
F42	10 A	Front windshield wiper automatic return.
F43	20 A	Main ECU SPU 40-26.
F44	10 A	Rear windshield wiper automatic return.
F45	15 A	Roof windshield wiper automatic return. Side windshield wiper automatic return (OPTION).
F46	7,5 A	Relay (K3).
F47		Unused.
F48		Unused.
F49	5 A	Diagnostics plug.
F50	5 A	Roof light.
F51	5 A	"HARMONY" dashboard
F52		Unused.
F53		Unused.
F54	5 A	Immobilizer (OPTION).
F55	7,5 A	Car radio (OPTION).
F56	7,5 A	Relay (K2).
F57	7,5 A	Auxiliary ECU SPU 40-26 / SPU 25-15.
F58	20 A	Lighting, horn and indicator switch.
F59	15 A	Relay (K31).
F60		Unused.

F61	7,5 A	Left-hand turn signal.
F62	7,5 A	Right-hand turn signal.
F63	15 A	Dipped beam headlights.
F64	15 A	Main beam headlights.
F65	7,5 A	Left parking lights.
F66	7,5 A	Right parking lights.
F67	7,5 A	Rear fog lights.
F68		Unused.

F101		Unused.
F102	30 A	Relay (K1).
F103	60 A	Ignition switch.
F104	50 A	Module fuses 4 (F41 - F60).
F105	30 A	Air conditioning (OPTION).
F106		Unused.

K1		Fan/heating.
K2		Rotating beacon.
K3		(OPTION).
K4		Transmission cut-off.
K5		Reverse gear.
K6		Forward gear.

K21		Flashing light unit.
K22		Hazard warning lights.

K31		Flashing light unit power supply.
K32		Front windshield wiper speed 1 intermittence.
K33		Engine neutral.
K34		Backup lights and backup alarm.

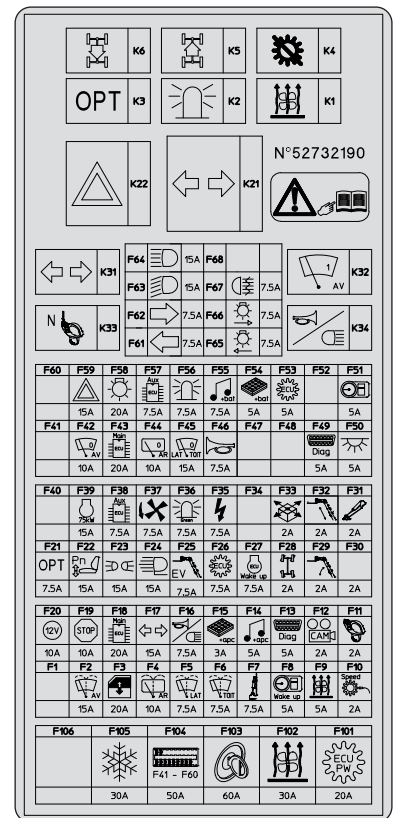

18 - FUSES AND RELAYS UNDER THE ENGINE HOOD

- Open the engine hood, remove cover 1 to gain access to the fuses and relays. Replace a blown fuse with a new fuse of the same quality and rating. Never use a repaired fuse.

MT 7/9/11/13 75D ...

F90	2A	Immobilizer (OPTION).
F91	20A	Fuel preheater (OPTION).
F92	60A	Relay (K51).
F93	30A	Engine control power unit.
F94	20A	Relay (K52).
F95	5A	Engine ECU wake-up.
F96	5A	Engine diagnostics plug power supply.
F97		Unused.
F98		Unused.
F99		Unused.

K24	30A	Fuel preheater (OPTION).
K25	30A	Fuel preheater (OPTION).
K51	70A	Preheat.
K52	40A	Fuel pump.

MT 13 100D ...

F71		Unused.
F72	20A	Relay power supply (K46).
F73		Unused.
F74	60A	Relay power supply (K41).
F75	30A	Relay power supply (K45).
F76	20A	Fuel preheater (OPTION).

F89	30A	Engine command module.
F90	2A	Immobilizer (OPTION).
F91	5A	NOx sensor power supply.
F92	5A	Temperature sensor.
F93	5A	Air intake valve power supply.
F94	5A	Engine diagnostics plug power supply.
F95	5A	Engine ECU wake-up.
F96	10A	Fuel pump "DEF".
F97	5A	Suction line preheat "DEF".
F98	5A	Return line preheat "DEF".
F99	7,5A	Pressure line preheat "DEF".
F100		Unused.

K24	30A	Fuel preheater (OPTION).
K25	30A	Fuel preheater (OPTION).
K41		Supply pump heating "DEF".
K42		Suction line preheat "DEF".
K43		Return line preheat "DEF".
K44		Pressure line preheat "DEF".
K45		Lines preheat "DEF".
K46		fuel pump "DEF".
K51	70A	Preheat glow-plugs.

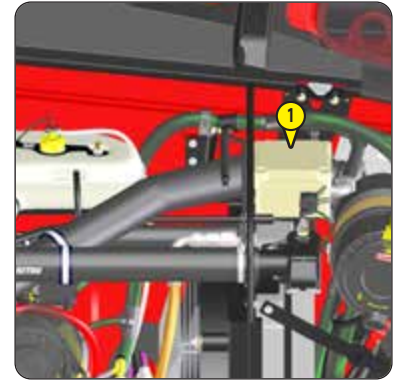

MT 7/9/11/13 75D ...

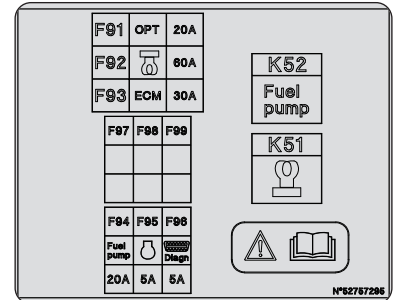

MT 13 100D ...

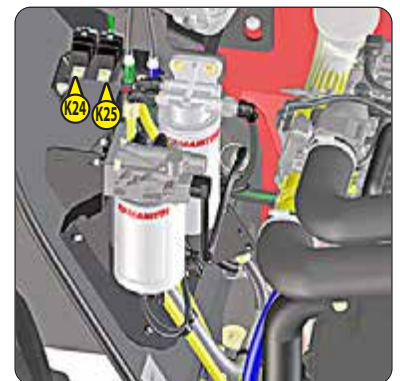
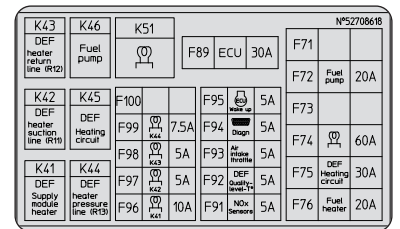

19 - FORWARD/NEUTRAL/REVERSE SELECTOR

Changing the direction of travel should take place at low speed without acceleration.

- NEUTRAL: The switch must be in the neutral position (position C) to start the machine.
- FORWARD: Push the switch forward (position A).
- REVERSE: Push the switch backward (position B). Reversing lights and a backup alarm indicate that the machine is traveling in reverse.

N.B.: Backup alarm (OPTIONAL or STANDARD).

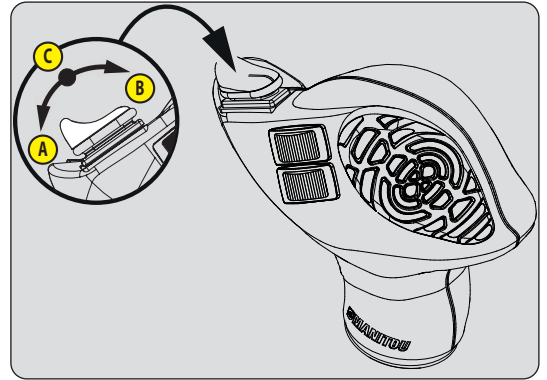

SAFETY FOR MOVING THE MACHINE

The operator must respect the following sequence to move the machine forward or backward:

- 1 - sit correctly in the seat,
- 2 - put on the seat belt,
- 3 - press the brake pedal,
- 4 - deactivate the parking brake,
- 5 - put the forward/reverse selector in forward or reverse,
- 6 - release the brake pedal,

N.B.: The alternate display of the forward or reverse section arrow  on the information screen requires the selector to be set to neutral.

The operator must respect the following sequence to immobilize the machine:

- 1 - press the brake pedal,
- 2 - set the forward/reverse selector to neutral,
- 3 - activate the parking brake,
- 4 - release the brake pedal,

N.B.: A discontinuous audible signal and a message on the screen will inform the driver if he has left the driver's cab without applying the parking brake.

20 - GEAR LEVER AND TRANSMISSION CUT-OFF

In order to change gear, it is necessary to cut off the transmission by pressing button 1 on the lever.

CONDITION OF USE OF GEARBOX RATIOS

On machines such as these, equipped with torque converters, it is not necessary to systematically set off in first gear and work up through the gears.

⚠ IMPORTANT ⚠

The gearbox ratio selection should be made carefully depending on the work to be performed. A poor choice may result in the extremely rapid rise of the gearbox oil temperature through excessive slipping of the converter, which could lead to serious gearbox damage (it is essential to stop and change the working conditions if the gearbox oil temperature indicator light comes on).

This poor choice may also result in the machine's performance deteriorating in forward gear: When the forward force increases, the forward speed in the r ratio (for example, in 3rd gear) may be lower than the forward speed that could be obtained with the gear below (in 2nd instead of 3rd).

In general, we would advise you to use the following gears according to the nature of the work being carried out.

- ON THE ROAD: Set off in 3rd gear and change up to 4th if the conditions and state of the road permit it. In hilly areas, set off in 2nd gear and change up to 3rd if the conditions and state of the road permit it.
- WITH A TRAILER ON THE ROAD: Set off in 2nd gear and change up to 3rd if the conditions and state of the road permit it.
- WHEN HANDLING: Use 3rd gear. In confined spaces use 2nd gear.
- LOADING (picking-up with bucket, manure fork, etc.): Use 2nd gear.
- EARTH MOVING: Use 1st gear.



21 - STEERING SELECTION

⚠ IMPORTANT ⚠

*Before selecting one of the three steering possibilities, align the 4 wheels in relation to the machine axis.
Never change the steering mode whilst driving.*



The green indicator lights on the information screen  come on to indicate the alignment of the wheels relative to the machine.

A - STEERING SELECTION LEVER

- A1 - Front steering wheels (road mode).
- A2 - Front and rear steering wheels in opposite directions (short steering).
- A3 - Front and rear steering wheels in the same direction (crab steering).

WHEEL ALIGNMENT CONTROL

⚠ IMPORTANT ⚠

Check the alignment of the front and rear wheels each time the machine is started.

Regularly check the alignment of the wheels when using the machine.

The wheels must be aligned and the machine must be in front steering wheels mode when used on public roads.

A green light illuminates on the dashboard when the wheels are aligned.

Contact your dealer if you have any questions.

- Select "short steering" (position A2).



- Turn the steering wheel and bring the rear wheels into alignment until the  indicator lamps light on the rear wheels.

- Select "road driving" (position A1).

- Turn the steering wheel and bring the rear wheels into alignment until the  indicator lamps light on the front wheels.

22 - ACCELERATOR PEDAL



23 - SERVICE BRAKE PEDAL AND TRANSMISSION CUT-OFF

The pedal acts on the front and rear wheels by means of a hydraulic brake system enabling the machine to be slowed down and stopped. Depending on the position of

the transmission cut-off switch , it enables the transmission to be cut off during free travel (⇐ PUSH BUTTON PANEL).



24 - FUNCTION FILES

These files contain the description of the hydraulic controls and the load charts for the attachments used on the machine.



25 - HYDRAULIC BOOM CONTROLS

⚠ IMPORTANT ⚠

Do not try to modify the hydraulic pressure of the system. If it malfunctions contact your dealer. ANY MODIFICATION INVALIDATES THE WARRANTY AND YOU WILL BE CRIMINALLY LIABLE IN THE EVENT OF AN ACCIDENT.

Use the hydraulic controls gently without jerking to avoid incidents caused by shaking the machine.

N.B.: When driving on the road, it is highly recommended (mandatory in Germany) that you cut off all the hydraulic movements (⏏ PUSH BUTTON PANEL).

HYDRAULIC CONTROLS ACTIVATION

This safety device prevents accidental operation of the hydraulic lifting, tilting, telescoping and attachment controls.

- Place your hand on the lever, activate the hydraulic controls by contact on sensor 1 and perform the hydraulic movement.
- Hydraulic controls activation is maintained on a timer while the machine is being used.

If necessary, reactivate the hydraulic controls.

A1 - LIFTING

A2 - LOWERING

B1 - CROWD

B2 - DUMP

C1 - TELESCOPIC BOOM EXTENSION

C2 - TELESCOPIC BOOM RETRACTION

N.B.: When completely retracting the telescopes, insistently operate the control so as to allow all the telescopes to retract fully.

D1 - ATTACHMENT (OPTION)

D2 - ATTACHMENT (OPTION)

E - BOOM HEAD SOLENOID VALVE (OPTION)

⏏ DESCRIPTION AND USE OF THE OPTIONS

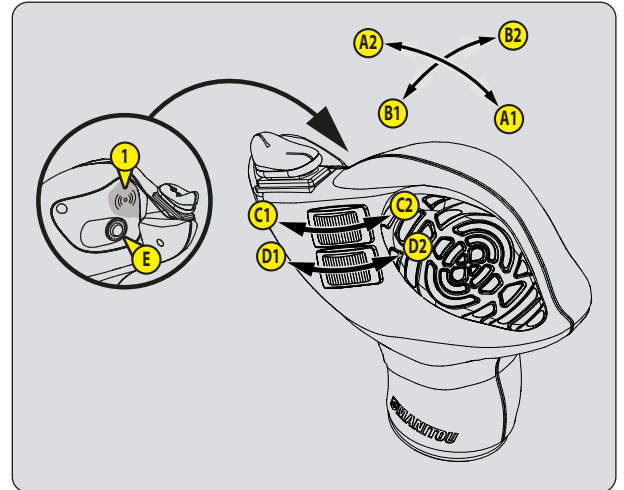

26 - STABILIZER CONTROLS

MT 1135/1335...

A1 - LEFT STABILIZER LIFTING

A2 - LEFT STABILIZER LOWERING

B1 - RIGHT STABILIZER LIFTING

B2 - RIGHT STABILIZER LOWERING



27 - FRAME LEVELING CONTROLS

MT 1135/1335...

 **FRAME LEVELING ON LEFT**

 **FRAME LEVELING ON RIGHT**



28 - HEATER CONTROL

A - FAN CONTROL

This 3-speed control allows the air to be ventilated through the air vents.

B - TEMPERATURE CONTROL

Adjusts the temperature inside the cab.

- B1 - The fan pumps in the air at ambient temperature.
- B2 - The fan pumps in warm air.

The intermediate positions allow the temperature to be adjusted.

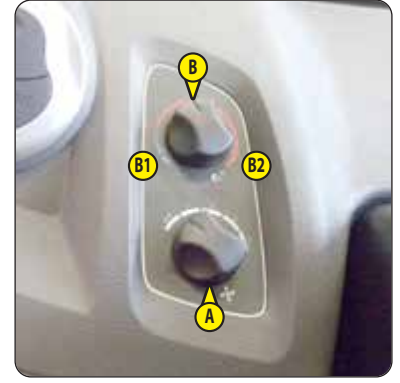

29 - AIR CONDITIONING CONTROLS (AIR CONDITIONING OPTION)

⚠ IMPORTANT ⚠

The air conditioning only works if the machine has been started.

When using your air conditioning, it is essential to work with the cab closed.

In winter: So as to ensure that the air conditioning unit is correctly operated and completely efficient, start up the compressor once a week, even for a short period of time, in order to lubricate the internal seals.

In cold weather: Warm the engine before switching on the compressor, in order to allow the coolant that has collected in the liquid state at the lowest point of the compressor's circuit to turn into gas under the effect of the heat given off by the engine, as the compressor is liable to be damaged by coolant in the liquid state.

If it seems to you that the air conditioning is not working properly, have it inspected by your dealer.

Never try to repair any faults yourself.

A - FAN CONTROL

This 3-speed control allows the air to be ventilated through the air vents.

B - TEMPERATURE CONTROL

Adjusts the temperature inside the cab.

- B1 - The fan pumps in cold air.
- B2 - The fan pumps in warm air.

The intermediate positions allow the temperature to be adjusted.

C - AIR CONDITIONING CONTROL

This control with a pilot light allows the air conditioning unit to be switched on.

HEATING MODE

- The controls must be adjusted in the following way:
 - C - Control with pilot light off.
 - B - At the desired temperature.
 - A - At the desired speed: 1, 2 or 3.

AIR CONDITIONING MODE

- The controls must be adjusted in the following way:
 - C - Control with indicator lamp on.
 - B - At the desired temperature.
 - A - At the desired speed: 1, 2 or 3.

DEFROST MODE

- The controls must be adjusted in the following way:
 - C - Control with indicator lamp on.
 - B - At the desired temperature.
 - A - At speed 2 or 3.
- For optimum effectiveness, close the heating vents.



30 - DEMIST VENTS

These vents allow the windshield and side windows to be demisted. For optimum effectiveness, close the heating vents.



31 - HEATING VENTS

These swiveling heating vents, which can be shut off, allow you to direct and adjust the flow inside the cab.

32 - DOOR OPENING AND CLOSING HANDLE

Two keys are provided with the machine to enable the cab to be locked.

- Pull on the handle to open the door.
- Place your hand on the handle and push to close the door.



- Press the latch 1 and push to open the door.
- Pull on the handle 2 to close the door.

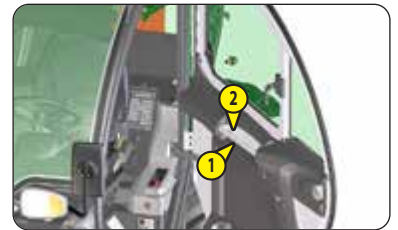

33 - DOOR WINDOW RELEASE BUTTON

- Press the button 1 to release the door from the inside.

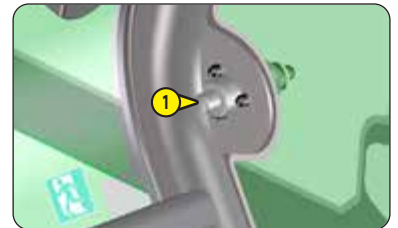

- Lift the latch 2 to release the door from the outside.

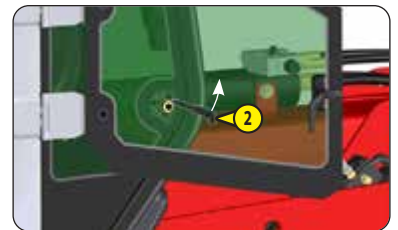

34 - DOOR WINDOW OPENING AND CLOSING HANDLE

- Pivot up to open.
- Pivot down to close.



DOOR WINDOW STAY

- Position of the door window stay to preserve the seal.

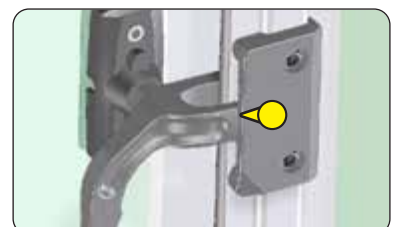

35 - HANDLE FOR REAR WINDOW OPENING

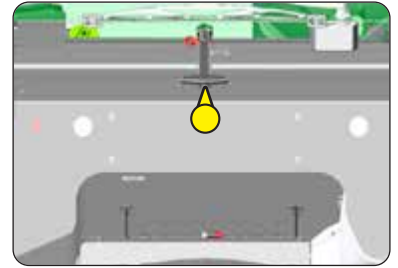

36 - DOCUMENT STORAGE NET

Make sure that the operator's manual is in the right place, i.e. in the document holder net.

N.B.: An OPTIONAL waterproof document-holder is available.

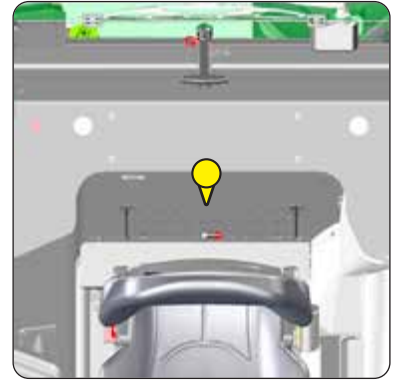

37 - FRONT HEADLIGHTS

- A - Front left-hand indicator light.
- B - Front left-hand dipped headlight.
- C - Front left-hand headlight.
- D - Front left-hand sidelight.
- E - Front right-hand indicator light.
- F - Front right-hand low beam headlight.
- G - Front left-hand high beam headlight.
- H - Right front sidelight.



38 - REAR LIGHTS

- A - Rear left-hand indicator light.
- B - Rear left-hand stop light.
- C - Left rear light.
- D - Rear fog light.
- E - Rear reversing light.
- F - Right rear light.
- G - Rear right-hand stop light.
- H - Rear right-hand indicator light.

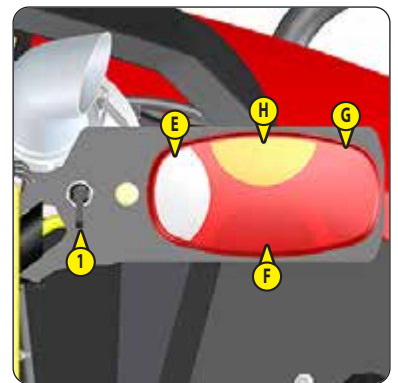
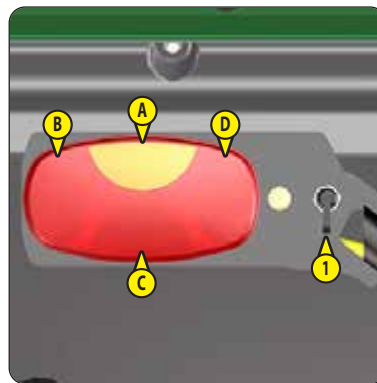

POSITION OF LIGHTS IN ROAD TRAFFIC

MT 1335...

⚠ IMPORTANT ⚠

Position the lights horizontally for driving on the road using the locks 1.

POSITION OF LIGHTS IN A NARROW SPACE

MT 1335...

⚠ IMPORTANT ⚠

*Position the lights vertically to reduce the machine's size using the locks 1.
This position is not authorized for driving on the road*

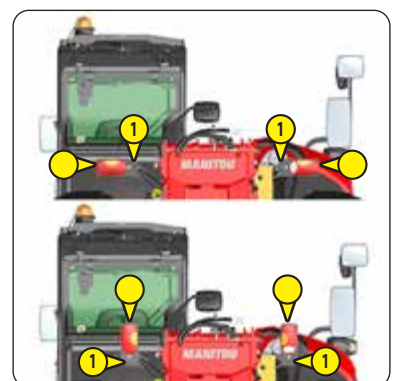

39 - ROTATING BEACON LIGHT

The magnetic rotating beacon light must be clearly visible on the roof of the cab and plugged into socket 1.



40 - SUN VISOR

41 - ROOF LIGHT

42 - COAT HOOK



43 - INSIDE REAR-VIEW MIRROR (OPTION)

44 - LEVEL INDICATOR

A - SPIRIT LEVEL

Enables the operator to check that the machine is in the horizontal position.

B - TILT INDICATOR

MT 1135/1335...

When the two marks are aligned, the chassis is parallel with the front axle.

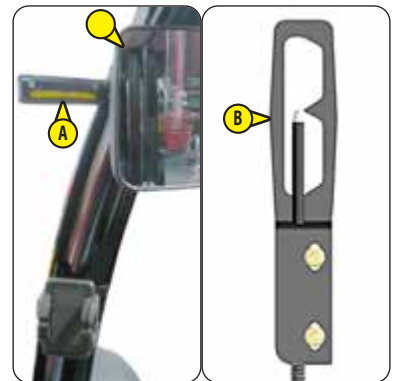

45 - STEERING WHEEL ADJUSTMENT LEVER (OPTION)

This handle enables the angle and height of the steering wheel to be adjusted.

- Pull the knob backward.
- Adjust the steering wheel to the desired position.
- Push the knob back to lock the steering wheel in position.



46 - BOOM SAFETY WEDGE

⚠ IMPORTANT ⚠

Only use the wedge supplied with the machine.

The machine is equipped with a boom safety wedge which must be installed on the rod of the lifting cylinder when working beneath the boom (⚠ 1 - OPERATING AND SAFETY INSTRUCTIONS).



47 - FUEL TANK

As far as possible, keep the fuel tank well filled in order to minimize condensation due to the atmospheric conditions.

⚠ IMPORTANT ⚠

*Never smoke or approach with a flame during filling operations or when the tank is open.
Never refill while the engine is running.*

- Check the fuel gage on the dashboard.
- If necessary, add diesel (↩ 3 - MAINTENANCE: LUBRICANTS AND FUEL).
- Remove the cap 1 using the ignition key.
- Fill the fuel tank with clean diesel filtered through the filler port.
- Refit the cap.
- Visually check that there is no leakage in the tank and pipes.



48 - TANK "DEF" (Diesel Exhaust Fluid)

MT 13 100D ...

Set the machine on level ground with the engine stopped.

⚠ IMPORTANT ⚠

*Diesel exhaust fluid is corrosive: protect the bodywork and wear personal protective equipment (gloves and goggles).
The Diesel Exhaust Fluid level is important. Operating with a low or empty DEF tank level may affect engine performance.*

- If necessary, add diesel exhaust fluid (↩ 3 - MAINTENANCE: LUBRICANTS AND FUEL).
- Remove the cap 1.
- Slowly fill the tank to the bottom of the filler neck.
- Always maintain a good level to avoid alternation of the product.
- Refit the cap.



QUALITY "DEF" (Diesel Exhaust Fluid)

The diesel exhaust fluid quality can be measured using a refractometer. The diesel exhaust fluid must comply with standard ISO 22241-1 with a urea concentration of 32.5%.

Refractometer (MANITOU part number: 959709)

STORAGE "DEF" (Diesel Exhaust Fluid)

Up to 4 months without using the machine, check the quality of the diesel exhaust fluid with a refractometer.

Beyond 4 months, replace the diesel exhaust fluid. Empty and rinse the tank.

N.B.: For a prolonged shutdown of the machine, ↩ 1 - OPERATING AND SAFETY INSTRUCTIONS: PROLONGED MACHINE SHUTDOWN.

N.B.: A locking tank cap is available as an OPTION.

49 - BATTERY CASING



TOWING DEVICE

⚠ IMPORTANT ⚠

Do not tow a trailer or an attachment that is not in perfect working condition.

Using a trailer in poor condition may affect the machine's steering and braking, and hence the safety of the assembly.

If a third party helps in coupling or uncoupling the trailer, this person must remain visible to the driver at all times and must wait until the machine has stopped, the parking brake is applied and the engine is switched off before performing the operation.

Located at the rear of the machine, this device is used to attach a trailer. Its capacity is limited for each machine by the authorized gross vehicle weight, tractive effort and maximum vertical force on the coupling point. This information is given on the manufacturer's plate fixed to each machine (← IDENTIFICATION OF THE MACHINE).

- To use a trailer, see current regulations in your country (maximum running speed, braking, maximum weight of trailer, etc.).
- Verify the trailer's condition before using it (tire condition and pressures, electrical connection, hydraulic hose, brake system, etc.).

1 - TOWING PIN

⚠ IMPORTANT ⚠

Be careful not to get your fingers caught or crushed during this operation.

Do not forget to put the cotter pin back in place.

When uncoupling, make sure that the trailer is supported independently

COUPLING AND UNCOUPLING THE TRAILER

- To couple the trailer, position the machine as close as possible to the trailer ring.
- Stop the engine.
- Remove the pin 1, lift the towing pin 2 and place or remove the trailer ring.



2 - REAR-VIEW MIRROR

The rear-view mirror allows the machine to approach the trailer ring more precisely.



3 - REAR ELECTRIC SOCKET (OPTION)

- Connect the male plug to the female socket 1 on the machine and make sure the lights of the trailer or the light bar are working properly.



DESCRIPTION AND USE OF THE OPTIONS

8 - ANGULAR SECTOR ON BOOM	2-61
1 - WINDSHIELD GRILLE	2-79
2 - WATERPROOF DOCUMENT HOLDER	2-79
3 - REFLECTIVE BANDS	2-79
4 - LICENSE PLATE LIGHT	2-79
5 - FUEL PREHEATER.....	2-80
6 - ENGINE BLOCK HEATER.....	2-80
7 - PIN PAD "EasyMANAGER".....	2-80
8 - "STOP&START" ENGINE.....	2-81
9 - FAN REVERSAL.....	2-82
10 - REAR CAMERA	2-82
11 - BOOM ELECTRICAL PREDISPOSITION.....	2-83
12 - ATTACHMENT CIRCUIT WITH QUICK-RELEASE COUPLERS	2-83
13 - RETURN TO HYDRAULIC TANK.....	2-83
14 - ATTACHMENT CIRCUIT MANUAL OVERRIDE	2-84
15 - ATTACHMENT EASY HYDRAULIC CONNECTION.....	2-84
16 - ATTACHMENT HYDRAULIC LOCKING.....	2-85
17 - BOOM HEAD ELECTROVALVE	2-86
18 - BOOM HEAD ELECTROVALVE + HYDRAULIC ATTACHMENT LOCKING.....	2-88
19 - LIFTING RING ON SINGLE CARRIAGE.....	2-89
20 - GREEN ROTATING BEACON LIGHT (FOR UK ONLY)	2-89
21 - REAR PARKING AID.....	2-90
22 - FLASHING LIGHT.....	2-90
23 - RED ROTATING BEACON LIGHT	2-90
24 - SAFETY LOGIC DESCRIPTION.....	2-91
25 - DOOR WINDOW ANTI-BREACH BAR	2-91
26 - MARKS ON BOOM.....	2-92

1 - WINDSHIELD GRILLE

DESCRIPTION

The windshield grille provides additional protection for the operator from any external elements spattered on the windshield.

This grille must be removable from inside the cab to enable an emergency exit.

EMERGENCY EXIT

- After breaking the windshield with the emergency hammer, push (with force) on the windshield grille at A to remove it.



2 - WATERPROOF DOCUMENT HOLDER



3 - REFLECTIVE BANDS

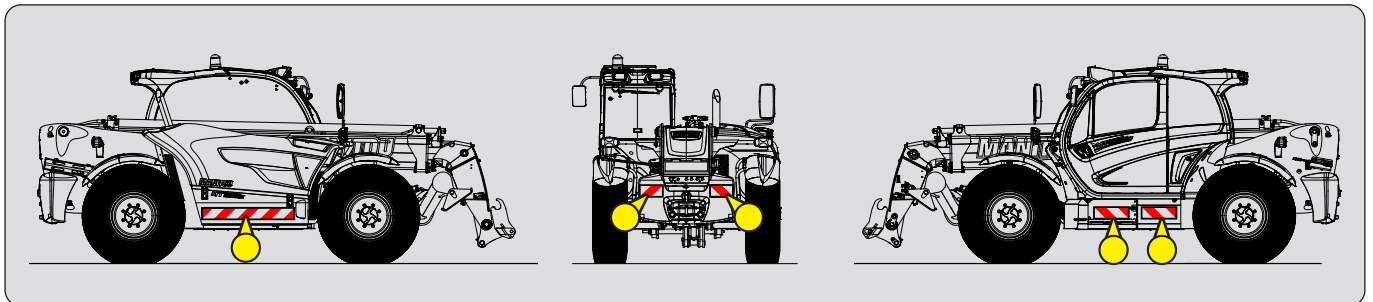

4 - LICENSE PLATE LIGHT



5 - FUEL PREHEATER

The paraffin particles found naturally in diesel crystallize at low temperatures. The fuel preheater limits their accumulation in the filter.

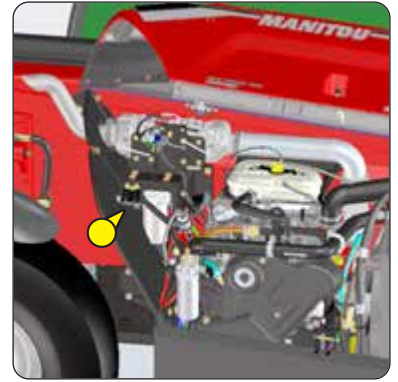

6 - ENGINE BLOCK HEATER

Enables the engine to be kept warm during prolonged periods of stoppage and thus improves engine starting.

ENVIRONMENTAL CONDITIONS FOR USE:

- Maximum ambient temperature for using preheat: 77°F (25 °C).

CONDITIONS FOR CONNECTION AND USE OF PREHEATING:

- The preheating system should not be used for an external ambient temperature higher than : 77°F (25 °C).
- It is essential that the power supply to the preheating system:
 - Is effected with a cable that conforms to the installation standards in force and contains a protective earth conductor.
 - Contains an appropriate sectioning system.
 - Include an appropriate short-circuit protection system (fuses or circuit breaker) and a ground-fault circuit breaker, sensitive to 30 mA.
- Only connect to and disconnect from the power supply while the unit is switched off and the engine is stopped.

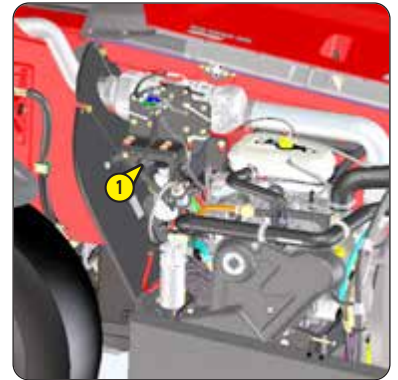

Make sure that the electrical extension is still correctly stored in its place in the document holder net.

7 - PIN PAD "EasyMANAGER"

A code must be created for the operator via the "EasyMANAGER" portal. For more information, contact your dealer.

OPERATION

BY ID CODE

- Switch on the machine's ignition. LED 1 comes on.
- Enter your ID code and confirm by pressing the "V" key.
- LED 2 comes on to confirm the operator's identification.
- Immediately start the machine, otherwise the identification process is canceled and LED 2 turns red.

N.B.: In case of an input error, LED 2 lights up red, press the "X" key, and wait 10 seconds before entering the correct identification code.

BY ID CARD

- Switch on the machine's ignition. LED 1 comes on.
- Present your ID card; an audible beep confirms that the card has been read.
- LED 2 comes on to confirm the operator's identification.
- Immediately start the machine, otherwise the identification process is canceled and LED 2 turns red.

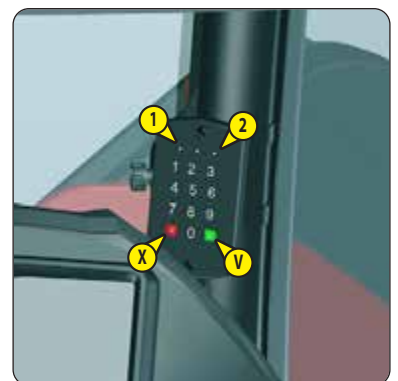



8 - "STOP&START" ENGINE

This function can take charge of engine shutdown to reduce consumption. It can be used if all of the following conditions are met within a timeframe defined by the operator.

- Engine on.
- Engine speed less than 1,000 rpm.
- No driver presence.
- No manual override in progress.
- No "stationary machine" exhaust regeneration.
- Parking brake activated.
- Engine coolant temperature higher than 122°F (50 °C).

TIME DELAY ADJUSTMENT



- Press the button  to display the "PREFERENCES" menu.
- Press the button  to select from the menus and sub-menus.

ENGINE > STOP&START

- Select a time delay between 1 and 30 minutes and press the  button to confirm.

ACTIVATION OF AUTOMATIC ENGINE CUT-OUT

- Press the  button to activate. The indicator light will come on, showing that it is in use.
- OR

- Press the button  to display the "PREFERENCES" menu.
- Press the button  to select from the menus and sub-menus.

ENGINE > STOP&START

- Activate the automatic engine cut-out and press the  button to confirm.

OPERATION

- The engine will stop automatically after the selected timeout has elapsed.
- Press the accelerator pedal or activate the hydraulic control lever to restart the engine.

⚠ IMPORTANT ⚠

The "STOP&START" function does not under any circumstances replace machine shutdown. You must shut down the machine at the end of the job or the end of the day (← 1 - OPERATING AND SAFETY INSTRUCTIONS: OPERATOR INSTRUCTIONS: OPERATING INSTRUCTIONS WITH AND WITHOUT LOAD: G - STOPPING THE MACHINE).



9 - FAN REVERSAL

MT 1135/1335 100D ...

Cleans the radiator core and the grille of the engine hood by reversing the air flow.

⚠ IMPORTANT ⚠



*The self-cleaning fan is operational from an engine coolant temperature of 104°F (40 °C).
When in use, beware of the risk of projection into the eyes.*



AUTOMATIC FAN REVERSAL

- The indicator lamp is on, the fan operates in self-cleaning mode for a few seconds once every 3 minutes.
- The default cycle time is 3 minutes.

SETTING THE CYCLE TIME

- Press the button  to display the "PREFERENCES" menu.
- Press the button  to select from the menus and sub-menus.

ENGINE > FAN DRIVE FAN REVERSAL (OPTION)

- Select the cycle time and press the  button to confirm.



FORCED SELF-CLEANING FAN

- Press the button to force a cleaning cycle. The indicator lamp will light when it is in use.
- Wait for the cycle to finish before forcing another.

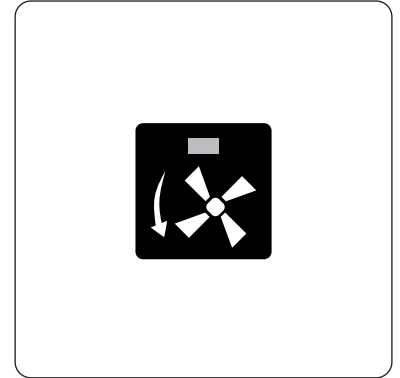

10 - REAR CAMERA

The rear camera can operate in manual or automatic mode:

- Turn the monitor on by clicking on "POWER".
- On the menu screen, go to the options tab "OPT".
- Select "CAM 1", then choose the required operating mode.



11 - BOOM ELECTRICAL PREDISPOSITION

Enables an electrical function to be used at the boom head.

ATTACHMENT LINE CONTROL

- Put switch 1 to position A (indicator lamp off).
- Push switch 3 forward or backward.

BOOM ELECTRIC FUNCTION CONTROL

- Set switch 1 to position B (indicator lamp on).
- Hold down button 2 and operate button 3 forward or backward.

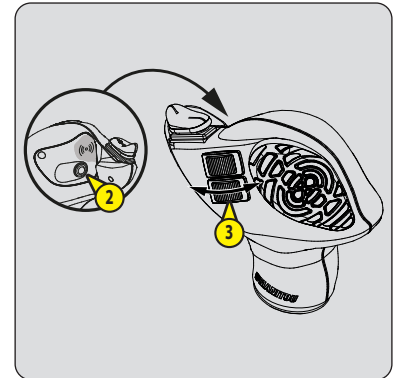

12 - ATTACHMENT CIRCUIT WITH QUICK-RELEASE COUPLERS



13 - RETURN TO HYDRAULIC TANK

Allows the connection of an attachment fitted with a hydraulic tank return.

- Position A to avoid premature wear of the hose.
- Position B to connect the attachment fitted with a hydraulic tank return.

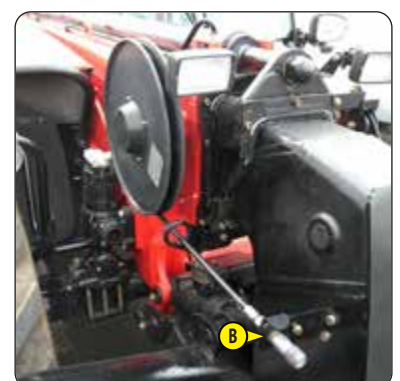
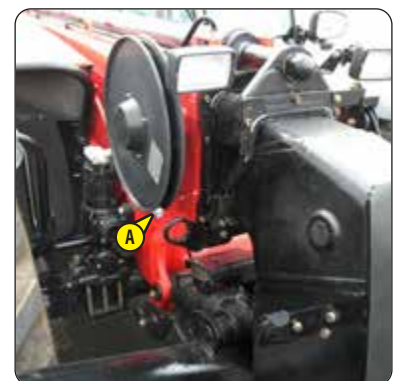







14 - ATTACHMENT CIRCUIT MANUAL OVERRIDE





⚠ IMPORTANT ⚠

This OPTION should only be used with an attachment that requires continuous hydraulic movement such as: a sweeper, feed wagon, mixer, sprayer, etc. It is strictly prohibited for handling operations and for all other attachments (winch, crane, crane jib with winch, hook, etc.).

USING AND STORING MANUAL OVERRIDE

- Press the  button to select the operating mode .
- Hold down the  button;  will appear on the information screen.
- Press buttons   to set the flow rate.
- Press the  button to confirm and set.

ACTIVATING THE STORED MANUAL OVERRIDE

- Press the  button to activate manual override.
- Confirm by pressing the  button again or pressing the  button.
- Press the  button again to deactivate.





15 - ATTACHMENT EASY HYDRAULIC CONNECTION

For easy connection and disconnection of hydraulic attachments.

PUSH BUTTON OPERATION

- Switch on the machine's ignition.
- Press for two seconds on pushbutton 1 to release the attachment circuit hydraulic pressure.
- Connect or disconnect the quick couplers of the hydraulic attachment (≤ 4 - ADAPTABLE ATTACHMENTS AS AN OPTION ON THE RANGE: PICKING UP THE ATTACHMENTS).

PREFERENCES MENU BUTTON OPERATION

- Switch on the machine's ignition.
 - Press the button  to display the "PREFERENCES" menu.
 - Press the button  to select from the menus and sub-menus.
- | | | |
|------------|---|---------------------|
| HYDRAULICS | > | EASY CONNECT SYSTEM |
|------------|---|---------------------|
- Press knob  to confirm.
 - Connect or disconnect the quick couplers of the hydraulic attachment (≤ 4 - ADAPTABLE ATTACHMENTS AS AN OPTION ON THE RANGE: PICKING UP THE ATTACHMENTS).



16 - ATTACHMENT HYDRAULIC LOCKING

Enables the attachment to be locked onto the carriage and a hydraulic attachment to be used by the same circuit.

⚠ IMPORTANT ⚠

Once the attachment is locked, return valve 1 to position B to prevent accidental release of the attachment.

ATTACHMENT LOCKING CONTROL

- Set valve 1 to position A.
- Push switch 2 forward to lock the attachment and backward to release it.
- Set valve 1 to position B.

HYDRAULIC ATTACHMENT CONTROL

- Set valve 1 to position B.
- Push switch 2 forward or backward.

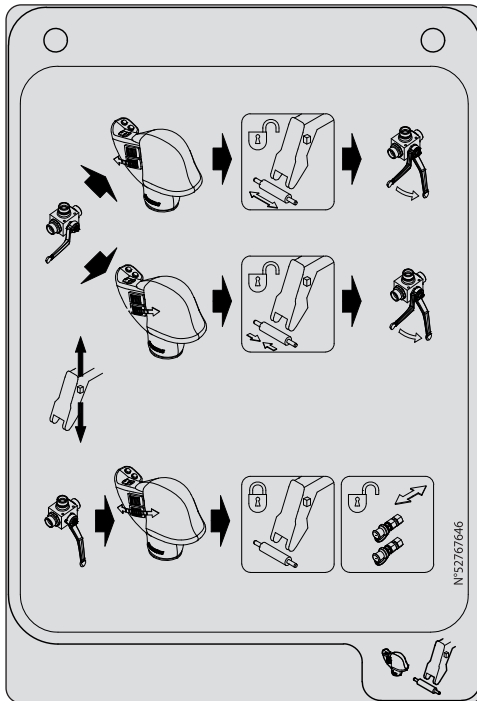
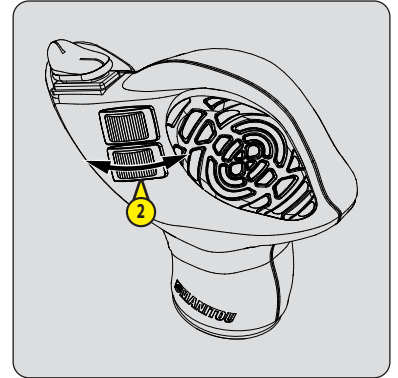
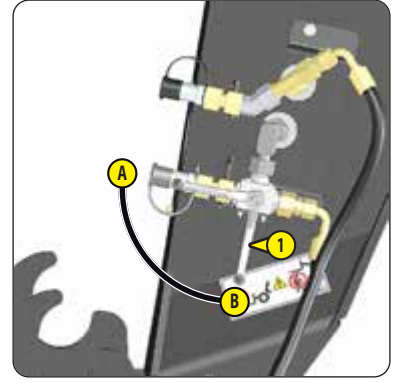

17 - BOOM HEAD ELECTROVALVE

ATTACHMENT OPERATING WITHOUT ELECTROVALVE

- Position the support to avoid premature wear of the electrical cable.

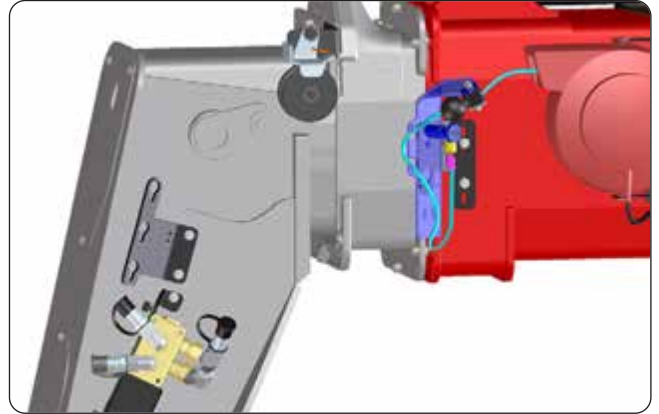

ATTACHMENT OPERATING WITH ELECTROVALVE

- Disconnect the connector 1 from the counter-connector 2.
- Remove the support bracket 3 by pulling the lock thumbwheel 4 and turning it a quarter turn.
- Lock the support bracket 3 on the boom head support 5 using the lock 4 and by turning the thumbwheel a quarter turn.

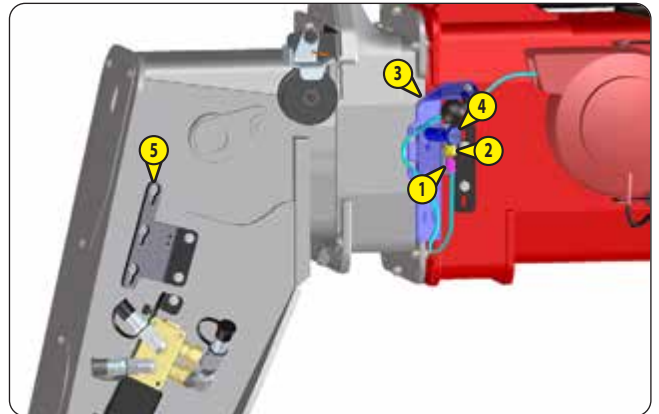

- Connect the connector 1 to the electrovalve 6.
- Feed the cable 11 into the collars 7.

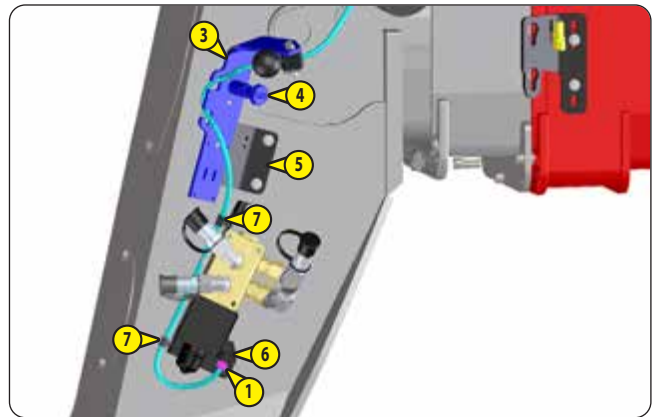

GUIDE PULLEY MT 935/1135/1335

Remove the pin 9 and rotate the cable guide 10 to the left.

- Feed the cable 11 over the pulley 12 and refit the cable guide 10.
- Lock the cable guide 10 with the pin 9.

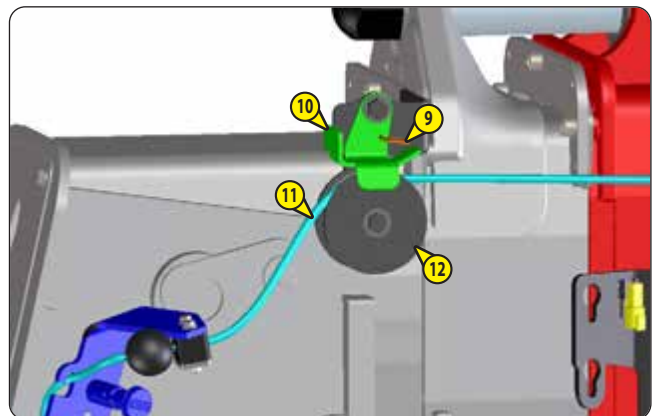

The electrovalve allows two hydraulic functions to be used on the attachment circuit.

N.B.: To make it easier to connect the hoses to the quick couplers, press button C on the electrovalve to relieve the pressure in the hydraulic system.

ATTACHMENT LINE CONTROL "C1-C4"

- Push switch 1 forward or backward.

ATTACHMENT LINE CONTROL "C2-C3"

- Hold down button 2 and operate button 1 forward or backward.

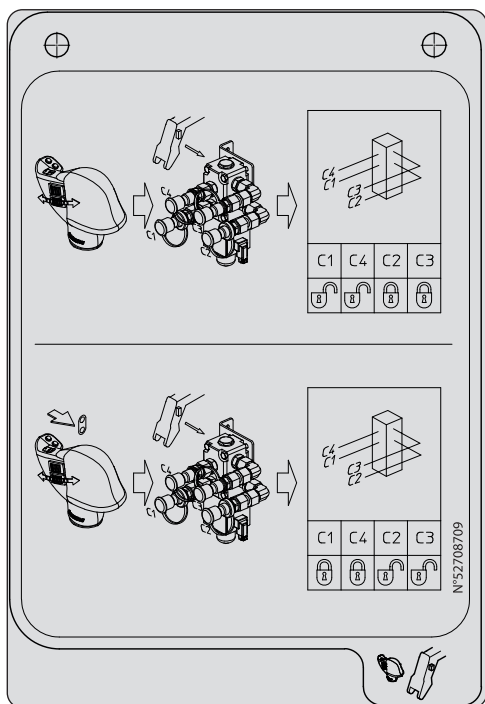
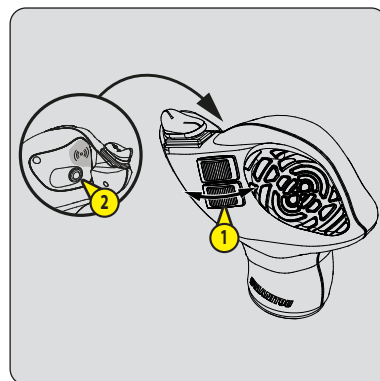
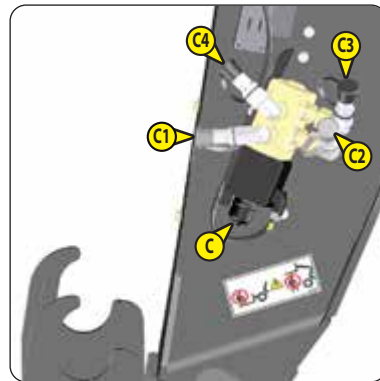

18 - BOOM HEAD ELECTROVALVE + HYDRAULIC ATTACHMENT LOCKING

The addition of these two options on the attachment line allows two hydraulic functions to be used and locks the attachment onto the carriage.

Enables use of two hydraulic functions on the attachment circuit.

N.B.: To make it easier to connect the quick couplers, relieve the pressure in the hydraulic system by pressing button C on the electrovalve.

⚠ IMPORTANT ⚠

Once the attachment is locked, return valve 1 to position B to prevent accidental release of the attachment.

ATTACHMENT LINE CONTROL "C1-C4"

- Set valve 1 to position B.
- Push switch 2 forward or backward.

ATTACHMENT LINE CONTROL "C2-C3"

- Set valve 1 to position B.
- Hold down button 3 and operate button 2 forward or backward.

ATTACHMENT LOCKING CONTROL

- Set valve 1 to position A.
- Hold down button 3 and push button 2 forward to lock the attachment and backward to release it.
- Set valve 1 to position B.

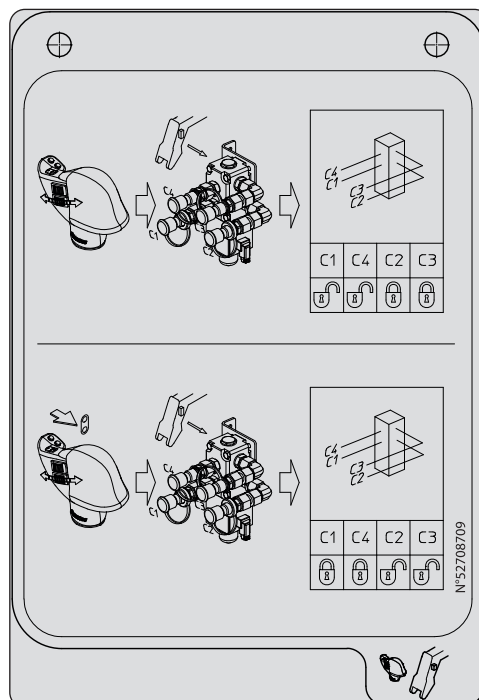
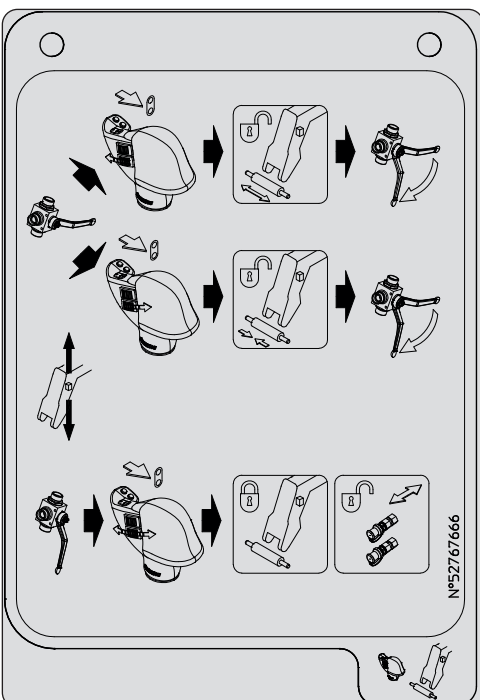
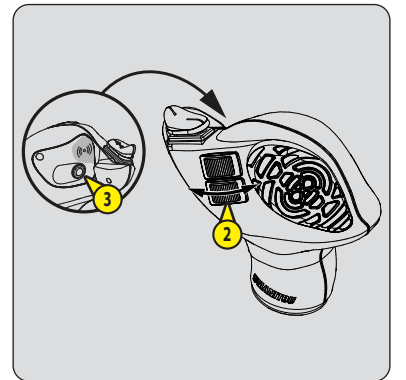
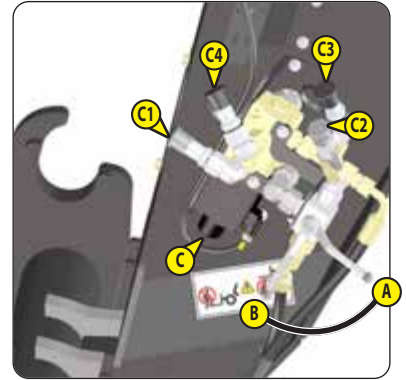

19 - LIFTING RING ON SINGLE CARRIAGE

CONDITIONS OF USE

⚠ IMPORTANT ⚠

Follow the instructions given in the instruction manual (↩ 1 - OPERATING AND SAFETY INSTRUCTIONS: INSTRUCTIONS ON HANDLING LOADS), in addition to those given below.

- The lifting ring must be used WITHOUT FORKS AND ATTACHMENTS, but the angle of inclination of the carriage must be same as when the forks are used in the horizontal position.
- Check the maximum authorized angle, which is 45°, on the screen.
- Do not change the angle of the carriage while using the lifting ring.
- The lifting hook, the chains and slings shall have a minimum capacity of 3000 kg with a safety coefficient of 4 in relation to breakage.

⚠ IMPORTANT ⚠

The load charts are calculated for use with forks or attachments (↩ LOAD CHARTS).

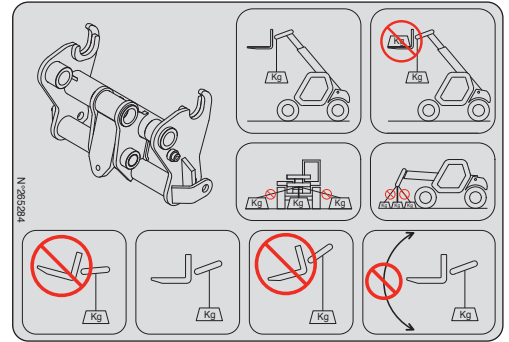

20 - GREEN ROTATING BEACON LIGHT (FOR UK ONLY)

The rotating beacon light must be visible on the roof of the cab and plugged in to socket 1.

- The rotating beacon light indicates that the operator has fastened the seat belt.
- Do not use the green rotating beacon light on public roads.

↩ SWITCHES

↩ SAFETY LOGIC DESCRIPTION



21 - REAR PARKING AID

Progressive visual and audible alarm.

- 2M50 to 1M00 => 1 light bar + 1 beep intermittently.
- 1M00 to 0M60 => 4 light bars + 4 beeps intermittently.
- 0M60 to 0M00 => 7 light bars + continuous beep.

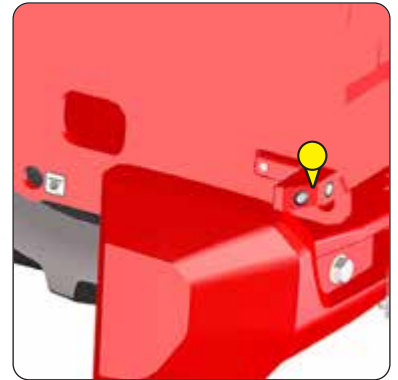

22 - FLASHING LIGHT

SAFETY LOGIC DESCRIPTION



23 - RED ROTATING BEACON LIGHT

The magnetic rotating beacon light must be clearly visible on the roof of the cab and plugged in to 12 V socket 1.

SWITCHES

SAFETY LOGIC DESCRIPTION



24 - SAFETY LOGIC DESCRIPTION

	Dashboard warning message.
	Machine travel (km/h).
	Cab door.
	Boom angle.
	Seat belt
	Presence of driver on seat.
	Machine lateral angle.
	Rear axle offloading + deactivation of "aggravating" hydraulic movement cut-off
	Cab flashing light + red rotating beacon light.
	Permanently

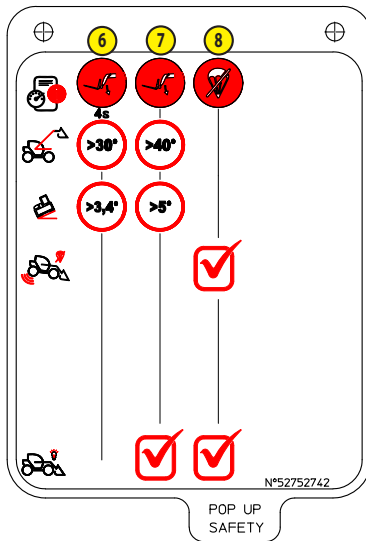
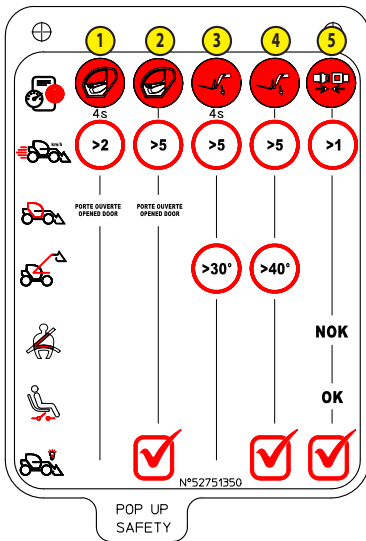

- ① => Risky driving - Close the door
- ② => Risky driving - Close the door
- ③ => Risky driving - Lower the boom
- ④ => Risky driving - Lower the boom
- ⑤ => Risky driving - Put on the seat belt
- ⑥ => Risky driving - Lower the boom
- ⑦ => Risky driving - Lower the boom
- ⑧ => Stability system deactivation

25 - DOOR WINDOW ANTI-BREACH BAR

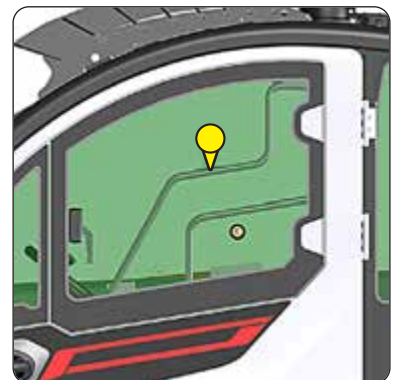

26 - MARKS ON BOOM

The marking indicates the outreach of the boom and therefore improves reading of the load charts.

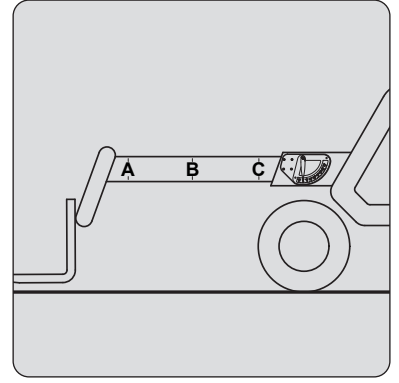

3 - MAINTENANCE

3 - MAINTENANCE

ORIGINAL MANITOU SPARE PARTS AND EQUIPMENT	3-3
MACHINE MAINTENANCE	3-4
DAILY AND WEEKLY MAINTENANCE	3-4
MANDATORY FIRST 500 HOURS OR 6 MONTHS OF SERVICE	3-5
PERIODIC MAINTENANCE	3-6
OCCASIONAL MAINTENANCE AND OPERATION	3-8
FILTER CARTRIDGES AND BELTS	3-9
LUBRICANTS AND FUEL	3-10
➤ 10H - DAILY SERVICE OR EVERY 10 HOURS OF SERVICE	3-12
➤ 50H - WEEKLY MAINTENANCE OR EVERY 50 HOURS OF SERVICE	3-14
➤ ① 500H - PERIODIC MAINTENANCE - EVERY 500 HOURS OF SERVICE OR 1 YEAR	3-20
➤ ② 1000H - PERIODIC MAINTENANCE - EVERY 1000 HOURS OF SERVICE OR EVERY 2 YEARS	3-25
➤ ③ 2000H - PERIODIC MAINTENANCE - EVERY 2000 HOURS OF SERVICE OR EVERY 4 YEARS	3-33
➤ OCCASIONAL MAINTENANCE	3-37
➤ OCCASIONAL OPERATION	3-40

ORIGINAL MANITOU SPARE PARTS AND EQUIPMENT

OUR MACHINES MUST BE SERVICED USING ORIGINAL MANITOU PARTS.

BY ALLOWING THE USE OF NON ORIGINAL MANITOU PARTS, YOU RISK:

⚠ IMPORTANT ⚠

THE USE OF COUNTERFEIT PARTS OR COMPONENTS NOT APPROVED BY THE MANUFACTURER MEANS YOU LOSE THE BENEFIT OF THE CONTRACTUAL GUARANTEE.

- Legally, incurring liability in the event of an accident.
- Technically, causing operating malfunctions and reducing the machine's service life.

BY USING ORIGINAL MANITOU PARTS FOR MAINTENANCE OPERATIONS, YOU BENEFIT FROM OUR KNOW-HOW

Through its network, MANITOU provides the user with,

- Know-how and competence.
- The guarantee of high-quality work.
- Original replacement parts.
- Help with preventive maintenance.
- Efficient help with diagnosis.
- Improvements as a result of feedback.
- Operator training.
- Only the MANITOU network has detailed knowledge of the design of the machine and therefore the best technical ability to provide maintenance.

⚠ IMPORTANT ⚠

ORIGINAL REPLACEMENT PARTS ARE DISTRIBUTED EXCLUSIVELY BY MANITOU AND ITS DEALER NETWORK.

The dealer network list is available on the MANITOU web site: www.manitou.com

MACHINE MAINTENANCE

DAILY AND WEEKLY MAINTENANCE



THE OPERATOR IS AUTHORIZED TO CARRY OUT THIS MAINTENANCE.

This maintenance enables the operator to keep the machine in a clean and safe condition.

MANDATORY FIRST 500 HOURS OR 6 MONTHS OF SERVICE



THIS SERVICE MUST BE CARRIED OUT AFTER THE FIRST 500 HOURS OF SERVICE OR WITHIN THE 6 MONTHS FOLLOWING THE START-UP OF THE MACHINE (WHICHEVER OCCURS FIRST).

PERIODIC MAINTENANCE



THE PERIODIC MAINTENANCE MUST BE CARRIED OUT BY A PROFESSIONAL APPROVED BY THE MANITOU NETWORK

MAINTENANCE SCHEDULE

This schedule enables the operator to keep the periodic maintenance on the machine up-to-date by reporting the total number of hours worked and the date of the service carried out by the professional approved by the MANITOU network.

OCCASIONAL MAINTENANCE AND OPERATION

These maintenance operations are to be carried out when needed for the safety and upkeep of the machine.

DAILY AND WEEKLY MAINTENANCE

🕒 10H - DAILY SERVICE OR EVERY 10 HOURS OF SERVICE

- CHECK	General inspection	3-12
- CHECK	Engine oil level	3-12
- CHECK	Coolant level	3-13
- CHECK	Fuel pre-filter	3-13

🕒 50H - WEEKLY MAINTENANCE OR EVERY 50 HOURS OF SERVICE

- CHECK	Gearbox oil level	3-14
- CHECK	Angle gear box seal	3-14
- CHECK	Front axle differential seal	3-14
- CHECK	Rear axle differential seal	3-14
- CHECK	Tire pressure	3-14
- CHECK	Wheel nut tightening	3-14
- CHECK	Front wheel reducer seals	3-15
- CHECK	Rear wheel reducer seals	3-15
- CHECK	Brake fluid level	3-15
- CHECK	Boom pad slide pathways	3-15
- CHECK	Hydraulic fluid level	3-16
- CHECK	Windshield washer liquid level	3-16
- CLEAN	Radiator cores	3-16
- CLEAN	Dry air filter cartridge	3-17
- CLEAN	Condenser harness (Air conditioning OPTION)	3-17
- REPLACE	Angle gear box oil *	3-17
- LUBRICATE	General lubrication	3-18

*** Only for the first 50 hours of service and then every 2,000 hours of service or 4 years.**

MANDATORY FIRST 500 HOURS OR 6 MONTHS OF SERVICE

FIRST 500 HOURS BEFORE THE FIRST 6 MONTHS

- If the machine has reached the first 500 hours of service before the first 6 months have expired, perform both the mandatory service and periodic 500 H service (🔍 ➡️ ① 500H - PERIODIC MAINTENANCE - EVERY 500 HOURS OF SERVICE OR 1 YEAR).

FIRST 6 MONTHS BEFORE THE FIRST 500 HOURS

- If the machine has not completed 500 hours of service in the first 6 months, carry out only the mandatory service.

➡️ MANDATORY SERVICE

- CHECK	Gearbox oil level	3-14
- CHECK	Angle gear box seal	3-14
- CHECK	Front axle differential seal	3-14
- CHECK	Rear axle differential seal	3-14
- CHECK	Tire pressure	3-14
- CHECK	Wheel nut tightening	3-14
- CHECK	Front wheel reducer seals	3-15
- CHECK	Rear wheel reducer seals	3-15
- CHECK	Brake fluid level	3-15
- CHECK	Boom pad slide pathways	3-15
- CHECK	Hydraulic fluid level	3-16
- CHECK	Windshield washer liquid level	3-16
- CLEAN	Radiator cores	3-16
- CLEAN	Dry air filter cartridge	3-17
- CLEAN	Condenser harness (Air conditioning OPTION)	3-17
- LUBRICATE	General lubrication	3-18
- CHECK	Countdown before "stationary machine" exhaust regeneration	3-20
- CHECK	Alternator belt tension	3-20
- CHECK	Compressor belt condition (Air conditioning option)	3-21
- CHECK	Hydraulic oil	3-21
- CHECK	Fork wear *	3-21
- CHECK	Tightening of 12 V electrical connections	3-22
- CHECK	Seat belt	3-25
- CHECK	Engine silent blocks *	3-32
- CHECK	Gearbox silent blocks *	3-32
- CHECK	Gear box controls *	3-32
- CHECK	Brake system pressure *	3-32
- CHECK	Boom pad wear *	3-32
- CHECK	Condition of wiring harnesses and cables *	3-32
- CHECK	Lights and signals *	3-32
- CHECK	Warning indicators *	3-32
- CHECK	Condition of rear-view mirrors *	3-32
- CHECK	Cab structure *	3-32
- CHECK	Chassis structure *	3-32
- CHECK	Attachment mounting system *	3-32
- CHECK	Condition of attachments *	3-32

*** Consult your dealer.**

PERIODIC MAINTENANCE

MAINTENANCE SCHEDULE

SCHEDULE →	↻ OR ↻		500 H or 1 YEAR	1000 H or 2 YEARS	1500 H or 3 YEARS	2000 H or 4 YEARS
	FIRST 6 MONTHS	FIRST 500 HOURS				
PERIODIC MAINTENANCE →	MANDATORY SERVICE	MANDATORY SERVICE + ①	①	①+②	①	①+②+③
MACHINE COUNTER →						
DATE OF SERVICING →						

SCHEDULE →	2500 H or 5 YEARS	3000 H or 6 YEARS	3500 H or 7 YEARS	4000 H or 8 YEARS	4500 H or 9 YEARS	5000 H or 10 YEARS	5500 H or 11 YEARS
	PERIODIC MAINTENANCE →	①	①+②	①	①+②+③	①	①+②
MACHINE COUNTER →							
DATE OF SERVICING →							

SCHEDULE →	6000 H or 12 YEARS	6500 H or 13 YEARS	7000 H or 14 YEARS	7500 H or 15 YEARS	8000 H or 16 YEARS	8500 H or 17 YEARS	9000 H or 18 YEARS
	PERIODIC MAINTENANCE →	①+②+③	①	①+②	①	①+②+③	①
MACHINE COUNTER →							
DATE OF SERVICING →							

→ ① 500H - PERIODIC MAINTENANCE - EVERY 500 HOURS OF SERVICE OR 1 YEAR

- CHECK	Countdown before "stationary machine" exhaust regeneration	3-20
- CHECK	Alternator belt tension	3-20
- CHECK	Compressor belt condition (Air conditioning option)	3-21
- CHECK	Hydraulic oil	3-21
- CHECK	Fork wear *	3-21
		<i>* Consult your dealer.</i>
- CHECK	Tightening of 12 V electrical connections	3-22
- REPLACE	Gearbox oil filter	3-22
- REPLACE	Engine oil	3-23
- REPLACE	Engine oil filter	3-23
- REPLACE	Front axle differential oil	3-24
- REPLACE	Rear axle differential oil	3-24
- REPLACE	Front wheel reducer oil	3-24
- REPLACE	Rear wheel reducer oil	3-24
- REPLACE	Hydraulic fluid tank breather cap	3-24
- REPLACE	Cab ventilation filters	3-24

2 1000H - PERIODIC MAINTENANCE - EVERY 1000 HOURS OF SERVICE OR EVERY 2 YEARS

ALSO CARRY OUT THE PERIODIC MAINTENANCE FOR 500 HOURS OF SERVICE.

- CHECK	Seat belt	3-25
- BLEED	Fuel tank	3-25
- REPLACE	Fuel tank breather	3-25
- REPLACE	Coolant	3-26
- REPLACE	Dry air filter cartridge	3-26
- REPLACE	Fuel pre-filter	3-27
- REPLACE	Fuel filter	3-27
- REPLACE	Feed pump filter "DEF"	3-28
- REPLACE	Tank breather "DEF"	3-28
- REPLACE	Tank filler strainer "DEF"	3-29
- REPLACE	Alternator belt	3-29
- REPLACE	Gearbox oil	3-30
- CLEAN	Gearbox sump strainer	3-30
- REPLACE	Hydraulic return oil filter cartridge	3-31
- CHECK	Engine silent blocks *	3-32
- CHECK	Gearbox silent blocks *	3-32
- CHECK	Gear box controls *	3-32
- CHECK	Brake system pressure *	3-32
- CHECK	Boom pad wear *	3-32
- CHECK	Condition of wiring harnesses and cables *	3-32
- CHECK	Lights and signals *	3-32
- CHECK	Warning indicators *	3-32
- CHECK	Condition of rear-view mirrors *	3-32
- CHECK	Cab structure *	3-32
- CHECK	Chassis structure *	3-32
- CHECK	Attachment mounting system *	3-32
- CHECK	Condition of attachments *	3-32
- REPLACE	Brake fluid *	3-32
- BLEED	Brake circuit *	3-32
- ADJUST	Brake *	3-32

** Consult your dealer.*

3 2000H - PERIODIC MAINTENANCE - EVERY 2000 HOURS OF SERVICE OR EVERY 4 YEARS

ALSO PERFORM THE 500 HOUR AND 1000 HOUR PERIODIC MAINTENANCE.

- CHECK	Wheel nut tightening torque	3-33
- CLEAN	Air conditioning (OPTION) *	3-33
		<i>* Consult your dealer.</i>
- REPLACE	Dry air filter safety cartridge	3-34
- REPLACE	Angle gear box oil	3-34
- REPLACE	Hydraulic oil	3-35
- REPLACE	Hydraulic oil tank suction strainer	3-35
- REPLACE	Fan reversal filter (OPTION)	3-35
- CHECK	Radiator *	3-36
- CHECK	Water pump and thermostat *	3-36
- CHECK	Alternator and starter *	3-36
- CHECK	Turbocharger *	3-36
- CHECK	Transmission pressures *	3-36
- CHECK	Steering *	3-36
- CHECK	Steering swivel joints *	3-36
- CHECK	Condition of boom assembly *	3-36
- CHECK	Bearings and bushings of the boom *	3-36
- CHECK	Condition of hoses and flexible pipes *	3-36
- CHECK	Condition of cylinders (leakage, rods) *	3-36
- CHECK	Hydraulic circuit pressures *	3-36
- CHECK	Chassis bearings and bushings*	3-36
- REPLACE	Compressor belt (Air Conditioning OPTION) *	3-36

** Consult your dealer.*

OCCASIONAL MAINTENANCE AND OPERATION

↻ OCCASIONAL MAINTENANCE

- CLEAN	Machine	3-37
- CLEAN	"Stationary machine" exhaust regeneration	3-37
- REPLACE	Wheels	3-38
- REPLACE	Battery	3-38
- ADJUST	Front headlights	3-39
- RESET	Longitudinal stability limiter and warning device	3-39

↻ OCCASIONAL OPERATION

- TOW/WINCH	Machine	3-40
- LIFT	Machine	3-40
- TRANSPORT	Machine	3-41

FILTER CARTRIDGES AND BELTS

➔ 1 500H - PERIODIC MAINTENANCE - EVERY 500 HOURS OF SERVICE OR 1 YEAR



ENGINE OIL FILTER

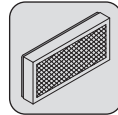

EXTERIOR CAB VENTILATION FILTER

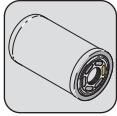

GEARBOX OIL FILTER



INTERIOR CAB VENTILATION FILTER

➔ 2 1000H - PERIODIC MAINTENANCE - EVERY 1000 HOURS OF SERVICE OR EVERY 2 YEARS

ALSO ADD THE FILTER CARTRIDGES FROM THE PERIODIC MAINTENANCE FOR 500 HOURS OF SERVICE.

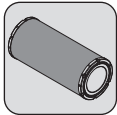

DRY AIR FILTER CARTRIDGE

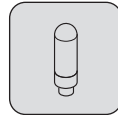

TANK BREATHER "DEF"

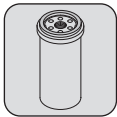

FUEL FILTER

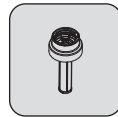

TANK FILLER STRAINER "DEF"

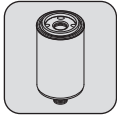

FUEL PRE-FILTER

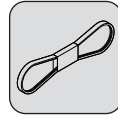

ALTERNATOR BELT



FUEL TANK BREATHER



HYDRAULIC RETURN OIL FILTER CARTRIDGE

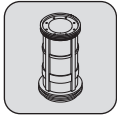

FEED PUMP FILTER "DEF"

➔ 3 2000H - PERIODIC MAINTENANCE - EVERY 2000 HOURS OF SERVICE OR EVERY 4 YEARS

ALSO ADD FILTER ELEMENTS FOR PERIODIC MAINTENANCE AT 500 HOURS AND 1,000 HOURS OF SERVICE.

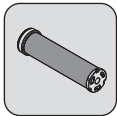

SAFETY DRY AIR FILTER CARTRIDGE

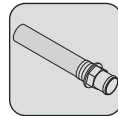

SUCTION STRAINER FOR HYDRAULIC OIL TANK

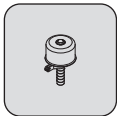

BREATHER FOR HYDRAULIC OIL TANK

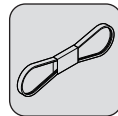

COMPRESSOR BELT

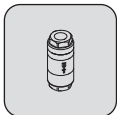

FAN REVERSAL

LUBRICANTS AND FUEL

⚠ IMPORTANT ⚠

USE THE RECOMMENDED LUBRICANTS AND FUEL:

- For topping up, oils may not be miscible.
- For oil changes, MANITOU oils are perfectly appropriate.

DIAGNOSTIC ANALYSIS OF OILS

If a service or maintenance contract has been set up with the dealer, a diagnostic analysis of engine, transmission and axle oils may be requested depending on the rate of use.

(*) REQUIRED FUEL SPECIFICATION

⚠ IMPORTANT ⚠

Halve the engine maintenance intervals when using biodiesel or HVO.

Pay special attention to the seals and fuel hoses when using HVO.

Replace the water separator O-ring when switching from diesel fuel to biodiesel fuel such as HVO, B11 or higher.

Use fuel that meets the following standards:

- Diesel EN590
- Diesel ASTM D975
- Biodiesel B20 EN16709
- Biodiesel HVO100 EN15940

(**) SPECIFICATION "DEF" (Diesel Exhaust Fluid)

- Aqueous urea solution at 32.5% (ISO22241)
- Solidification at 12.2 °F (-11 °C) and 10% expansion
- Non-flammable product
- Thermal degradation (>140 °F (60 °C))
- Storage between 23 °F (-5 °C) and 86 °F (30 °C)

⚠ IMPORTANT ⚠

Corrosive to metals, requires wearing personal protection (gloves and goggles).

RECOMMENDATION

ENGINE		RECOMMENDATION									
DESCRIPTION	CAPACITY	-40 °F	-22	-4	+14	+32	+50	+68	+86	+104	+122 °F
		-40 °C	-30	-20	-10	0	+10	+20	+30	+40	+50 °C
ENGINE	75D 8,98 US qt (8,5L)	5W30									
	100D 10,57 US qt (10L)	5W40 10W30 MANITOU EVOLOGY OIL 10W40 API CJ4 15W30 15W40									
COOLING CIRCUIT	17,96 US qt (17L)	COOLANT -35 °C									
FUEL TANK	27,2 US gal (103L)	HP NON-ROAD DIESEL (GNR) *									
TANK "DEF"	10,57 US qt (10L)	DEF **									
TRANSMISSION		RECOMMENDATION									
DESCRIPTION	CAPACITY										
GEARBOX	12,68 US qt (12L)	MANITOU DX IIG AUTOMATIC TRANSMISSION OIL									
ANGLE GEARBOX	1,59 US qt (1,5L)	MANITOU GERION TDL 75W90 OIL									

FRONT AXLE											
DESCRIPTION	CAPACITY	RECOMMENDATION									
REAR AXLE	7,61 US qt (7,2 L)	SPECIAL MANITOU OIL FOR IMMERSER BRAKES									
		-40 °F	-22	-4	+14	+32	+50	+68	+86	+104	+122 °F
		-40 °C	-30	-20	-10	0	+10	+20	+30	+40	+50 °C
WHEEL REDUCING GEAR	2 X 0,79 US qt (0,75 L)	MANITOU SAE80W90 MECHANICAL TRANSMISSION OIL									
		-40 °F	-22	-4	+14	+32	+50	+68	+86	+104	+122 °F
		-40 °C	-30	-20	-10	0	+10	+20	+30	+40	+50 °C
WHEEL GEAR REDUCER PIVOTS		MANITOU BLACK MULTI-PURPOSE LUBRICANT									
		-40 °F	-22	-4	+14	+32	+50	+68	+86	+104	+122 °F
		-40 °C	-30	-20	-10	0	+10	+20	+30	+40	+50 °C
AXLE OSCILLATION		MANITOU BLUE MULTI-PURPOSE LUBRICANT									
REAR AXLE											
DESCRIPTION	CAPACITY	RECOMMENDATION									
REAR AXLE	7,61 US qt (7,2 L)	SPECIAL MANITOU OIL FOR IMMERSER BRAKES									
		-40 °F	-22	-4	+14	+32	+50	+68	+86	+104	+122 °F
		-40 °C	-30	-20	-10	0	+10	+20	+30	+40	+50 °C
WHEEL REDUCING GEAR	2 X 0,79 US qt (0,75 L)	MANITOU SAE80W90 MECHANICAL TRANSMISSION OIL									
		-40 °F	-22	-4	+14	+32	+50	+68	+86	+104	+122 °F
		-40 °C	-30	-20	-10	0	+10	+20	+30	+40	+50 °C
WHEEL GEAR REDUCER PIVOTS		MANITOU BLACK MULTI-PURPOSE LUBRICANT									
		-40 °F	-22	-4	+14	+32	+50	+68	+86	+104	+122 °F
		-40 °C	-30	-20	-10	0	+10	+20	+30	+40	+50 °C
AXLE OSCILLATION		MANITOU BLUE MULTI-PURPOSE LUBRICANT									
BRAKES											
DESCRIPTION	CAPACITY	RECOMMENDATION									
BRAKE SYSTEM	0,79 US qt (0,75 L)	MANITOU MINERAL BRAKE FLUID									
BOOM											
DESCRIPTION	CAPACITY	RECOMMENDATION									
BOOM PAD SLIDE PATHWAYS		MANITOU BLACK MULTI-PURPOSE LUBRICANT									
		-40 °F	-22	-4	+14	+32	+50	+68	+86	+104	+122 °F
		-40 °C	-30	-20	-10	0	+10	+20	+30	+40	+50 °C
GREASING OF THE BOOM		MANITOU BLUE MULTI-PURPOSE LUBRICANT									
HYDRAULICS											
DESCRIPTION	CAPACITY	RECOMMENDATION									
HYDRAULIC OIL TANK	21,1 US gal (80 L)	ISO VG 100									
		ISO VG 68									
		MANITOU ISO VG 46 HYDRAULIC FLUID									
		ISO VG 37									
		ISO VG 32									
CAB											
DESCRIPTION	CAPACITY	RECOMMENDATION									
WINDSHIELD WASHER TANK	0,53 US qt (0,5 L)	WINDSHIELD WASHER FLUID									
CHASSIS											
DESCRIPTION	CAPACITY	RECOMMENDATION									
STABILIZERS FRAME LEVELING		MANITOU BLUE MULTI-PURPOSE LUBRICANT									
		-40 °F	-22	-4	+14	+32	+50	+68	+86	+104	+122 °F
		-40 °C	-30	-20	-10	0	+10	+20	+30	+40	+50 °C

⚠ IMPORTANT ⚠

Consult maintenance personnel if there is doubt about the condition of the machine.

Note: the engine hood must be opened to carry out the general inspection of the machine. It must be closed once finished.

The operator must perform a visual and physical inspection of the machine:

- Check that the operator's manual is clean and complete.
- Check the stickers and make sure they are all present, clean and legible, <1 2 - DESCRIPTION: STICKERS.
- Check for leaks: battery fluid, hydraulic oil, lubricants, etc.
- Check the condition of the structure: absence of impacts, damage, cracked welding, corrosion, excessive mechanical play, wear, etc.
- Check the condition of the hydraulic components: pumps, distributors, valves, cylinders, hoses, etc.
- Check the condition of the mechanical components: wheels, tires, tie rods, shafts, etc.
- Check the condition of the tires, to detect cuts, blisters, wear, etc.
- Check the condition of the electrical components: control panels, control handles, switches, buttons, indicator lights, batteries, fuses, cables, harnesses, rotating beacon light, etc.
- Check the condition of covers, handles, locks, plugs, etc.
- Check if any parts are missing or loose: screws, nuts, pins, etc.
- Check that no parts are missing or have had unauthorized modifications.
- Check the general cleanliness of the machine
- Check the mounting and locking of the attachment.
- Check the mounting and adjustment of the rear-view mirrors.

⚠ IMPORTANT ⚠

Follow the operator instructions (<1 1 - OPERATING AND SAFETY INSTRUCTIONS: OPERATOR INSTRUCTIONS).

CLEANLINESS OF THE MACHINE

- Cleanliness of lights and rear-view mirror.
- Excess dirt or build-up of material (e.g. straw, flour, sawdust, organic waste, etc.).
- On a daily basis, according to the conditions of use and the environment, the operator should ensure that the machine is kept in a clean condition.
- Particular attention should be paid to accumulations of flammable materials (e.g. straw, flour, sawdust, organic waste, etc.) and fuel or lubricant leaks, as these significantly increase the risk of fire outbreaks.
- A regular inspection of the whole machine, especially the engine housing and the central part of the chassis, is necessary to see how frequently it needs to be cleaned to prevent these potential accumulations of material or leakages.

Set the machine on level ground with the engine off and let the oil drain into the sump.

- Open the engine hood.
- Pull out the dipstick 1.
- Clean the dipstick and check the correct level between the two notches.
- If necessary, add oil through the filler hole 2.
- Visually check that there is no leakage or seepage.

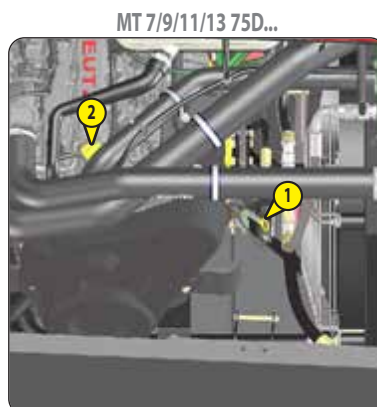

CHECK

Coolant level

Set the machine on level ground with the engine off and wait for the engine to cool down.

⚠ IMPORTANT ⚠

To avoid any risk of spraying or scalding, wait until the engine has cooled down before removing the cooling circuit filler plug.

In the event of an emergency, it is possible to use water as the coolant, but then proceed to drain the coolant circuit as quickly as possible.

- Open the engine hood.
- The liquid must be at the MAX. level on the expansion tank 1.
- If necessary, add coolant through the filler hole 2.
- Visually check that there is no leakage or seepage.

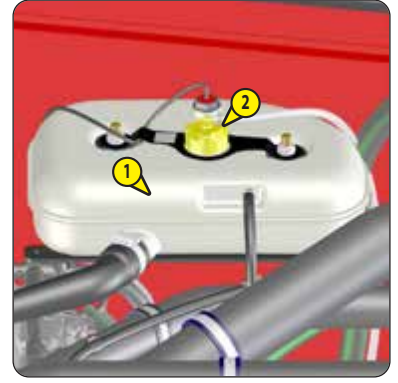

CHECK

Fuel pre-filter

⚠ IMPORTANT ⚠

Carefully clean the outside of the pre-filter and its holder, to prevent dust from getting into the system.

- Open the engine hood.
- Disconnect electrical wiring harness 1 from the fuel pre-filter.
- Place a hose on the drain plug 2 and the other end in a container.
- Unscrew the drain plug 2 by two turns.
- Allow the diesel fuel to flow out until it is free from impurities and water.
- Retighten drain plug 2 and reconnect the wiring harness 1.

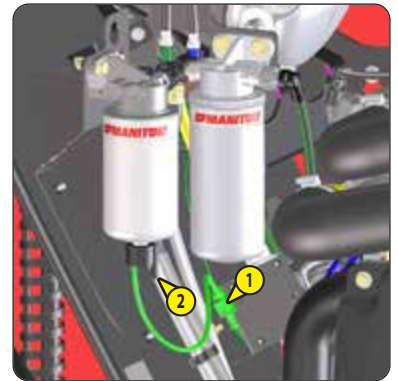

➔ 50H - WEEKLY MAINTENANCE OR EVERY 50 HOURS OF SERVICE

CHECK

Gearbox oil level

Park the machine on level ground with the boom raised and the engine stopped. Carry out the check within 5 minutes of the engine being stopped.

⚠ IMPORTANT ⚠

Raise the boom and place the boom safety wedge on the rod of the lifting cylinder (↖ 1 - INSTRUCTIONS AND SAFETY RECOMMENDATIONS: MACHINE MAINTENANCE INSTRUCTIONS).

- Remove the plastic cap 1.
- Pull out the dipstick 2.
- Wipe the dipstick and check the correct level between the MIN and MAX marks.
- If necessary, add oil (↖ 1000H: REPLACE Gearbox oil).
- Visually check that there is no leakage or seepage.

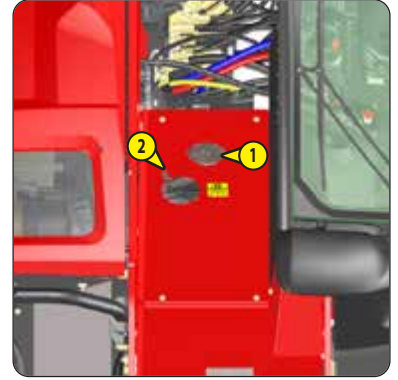

CHECK

Angle gear box seal

Set the machine on level ground with the engine stopped.

- Visually check that there is no leakage or seepage.
- If there is any leakage or seepage, check the level:
 - Remove the level plug 1, the oil should be flush with the edge of the hole.
 - If necessary, add new oil through the same hole.
 - Refit and tighten the level plug 1 (tightening torque 22,1 lb-pi ± 3,6 lb-pi (30 N.m ± 5 N.m)).



CHECK

Front axle differential seal

CHECK

Rear axle differential seal

Set the machine on level ground with the engine stopped.

- Visually check that there is no leakage or seepage.
- If there is any leakage or seepage, check the level:
 - Remove the level plug 1, the oil should be flush with the edge of the hole.
 - If necessary, add oil through the filler hole 2.
 - Refit and tighten the plugs (tightening torque 30,2 lb-pi ± 5,9 lb-pi (41 N.m ± 8 N.m)).

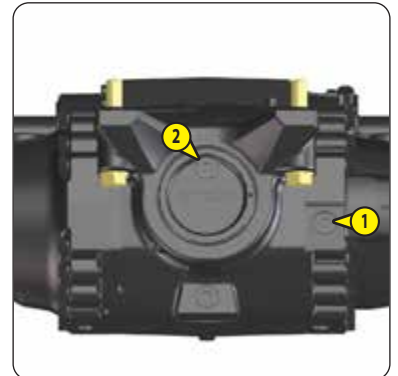

CHECK

Tire pressure

⚠ IMPORTANT ⚠

Check that the air hose is correctly connected to the tire valve before inflating and keep all persons at a distance during inflation. Inflate to the recommended tire pressures.

- Check and restore tire pressure, if necessary (↖ 2 - DESCRIPTION: TIRES).

CHECK

Wheel nut tightening

- Check the tightening of the wheel nuts (↖ 2000H - PERIODIC MAINTENANCE - EVERY 2,000 HOURS OF SERVICE OR EVERY 4 YEARS) for the tightening torque.
- Non-compliance with this instruction can lead to deterioration and breakage of the wheel lugs and distortion of the wheels.

CHECK

Front wheel reducer seals

CHECK

Rear wheel reducer seals

Set the machine on level ground with the engine stopped.

- Visually check that there is no leakage or seepage.
- If there is any leakage or seepage, check the level:
 - Place level plug 1 in a horizontal position.
 - Remove the level plug; the oil should be flush with the edge of the opening.
 - If necessary, add oil through the same hole.
 - Refit and tighten the level plug (tightening torque 30,2 lb-pi ± 5,9 lb-pi (41 N.m ± 8 N.m)).



CHECK

Brake fluid level

Place the machine on level ground.

⚠ IMPORTANT ⚠

If the brake fluid level is abnormal, consult your dealer.

- Open the protective casing 1 with the ignition key.
- Check tank 2. The correct level should be at the MAX. level on the tank.
- If necessary, add oil.
- Remove the cap 3.
- Add oil through filler port.
- Put the cap 3 back.
- Visually check that there is no leakage or seepage.
- Remove the protective casing 1 and lock using the ignition key.

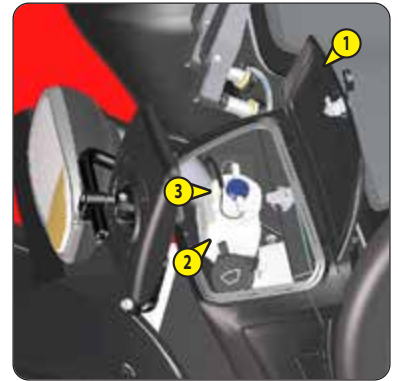

CHECK

Boom pad slide pathways

To preserve optimum operation, the pad slide pathways should be correctly lubricated:

⚠ IMPORTANT ⚠

MANDATORY GREASING OF THE BOOM AFTER:

Cleaning the boom, especially after using high pressure cleaner.

Machine not used for a long time.

- Fully extend the boom.
- Check the condition of the surface of the pad slide pathways, surface run in (steel whitened) without traces of corrosion.
- If necessary, lubricate the pad slide pathways.
- Telescope the boom several times in order to spread the lubricant evenly.
- Remove the surplus lubricant.



⚠ IMPORTANT ⚠

If the machine is used in an abrasive environment (dust, sand, coal), use lubricating varnish.

Consult your dealer.

CHECK

Hydraulic fluid level

Place the machine on level ground with the engine stopped, and the boom retracted and lowered as far as possible.

⚠ IMPORTANT ⚠

Use a very clean funnel and clean the top of the oil can before filling.

- Check dipstick 1, the correct level must be at the level of the red dot.
- If necessary, add oil.
- Remove the lock 2.
- Remove the cap 3.
- Refit the cap and its lock.
- Visually check that there is no leakage or seepage.



CHECK

Windshield washer liquid level

- Open the protective casing 1 with the ignition key.
- Visually check the level in the tank.
- If necessary, add windshield washer fluid.
- Remove the cap 2.
- Add windshield washer liquid through filler port.
- Refit the cap.

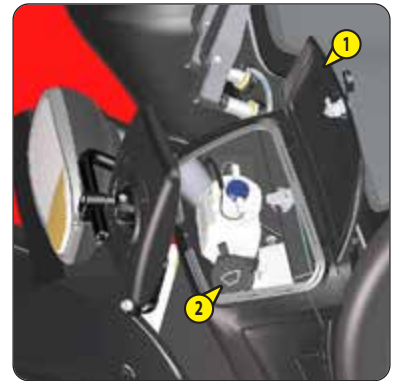

CLEAN

Radiator cores

⚠ IMPORTANT ⚠

In a polluting atmosphere, clean the radiator cores every day.

Do not use a water jet or high pressure steam as this could damage the fins.

- Open the engine hood.
- If necessary, clean the intake grille on the engine cover.
- Using a soft cloth, clean the radiator cores in order to remove as much dirt as possible.
- Clean the radiator using a compressed air jet aimed from the engine toward the radiator, in the opposite direction to the cooling air flow.



In case of use in a heavily dust-laden atmosphere, there are pre-filtration cartridges. The cartridge checking and cleaning interval must also be reduced.

⚠ IMPORTANT ⚠

- If the clogging indicator lamp comes on, this operation should be performed as soon as possible (maximum 1 hour).*
- Never use the machine without an air filter or with a damaged air filter.*
- Maintain a safety distance of 30 mm between the jet of air and the cartridge to avoid tearing or piercing the cartridge.*
- The cartridge must not be blown through close to the air filter casing.*
- Never clean the cartridge by tapping it on a hard surface.*
- Protect your eyes during this operation.*
- Do not clean the dry air filter cartridge by washing it in liquid.*
- Never clean the safety cartridge located inside the filter cartridge. Change it for a new one if it is clogged or damaged.*

- For the dismantling and refitting of the cartridge (< 1000H: REPLACE Air filter cartridge).
- Clean the filter cartridge using a compressed air jet (max. pressure 3 bars) directed from the top to the bottom and from the inside towards the outside at a minimum distance of 30 mm from the cartridge wall.
- Cleaning is completed when there is no more dust on the cartridge.
- Clean the cartridge seal surface with a damp, clean, lint-free cloth and grease with a silicone lubricant.
- Visually inspect the external condition of the air filter and its mounts. Check also the condition of the hoses and their attachments.

CLEAN

Condenser harness (Air conditioning OPTION)

⚠ IMPORTANT ⚠

In a polluting atmosphere, clean the radiator harness daily. Do not use a water jet or high-pressure steam as this could damage the condenser fins.

- Remove the protective grid 1 and clean it if necessary.
- Visually check whether the condenser is clean and clean it if necessary.
- Clean the condenser using a compressed air jet aimed in the same direction as the air flow.
- Clean with the fans running for best results.



REPLACE

Angle gear box oil *

Place the machine on level ground with the engine stopped and the angle gearbox oil still warm.

- Place a container under the drain plug 1 and unscrew the plug.
- Remove the level plug 2 and the filler cap 3.
- Refit and tighten the drain plug 1 (tightening torque 22,1 lb-pi ± 3,6 lb-pi (30 N.m ± 5 N.m)).
- Fill up with oil through the filler hole 3.
- The level is correct when the oil level is flush with the edge of opening 2.
- Refit and tighten the level plug 2 (tightening torque 22,1 lb-pi ± 3,6 lb-pi (30 N.m ± 5 N.m)).
- Refit and tighten the filler plug 3 (tightening torque 22,1 lb-pi ± 3,6 lb-pi (30 N.m ± 5 N.m)).
- Check for any possible leaks at the drain plug.

** Only for the first 50 hours of service and then every 2,000 hours of service or 4 years.*



To be carried out weekly, if the machine has been operated for less than 50 hours during the week.

⚠ IMPORTANT ⚠

In the event of prolonged use in an extremely dusty or oxidizing atmosphere, reduce this interval to 10 hours of service or every day.

Clean, then lubricate the following points with grease and remove the surplus.

BOOM

- 1 - Lubricators of the boom pin (2 lubricators).
- 2 - Lubricators of the carriage pin (1 lubricators).
- 3 - Lubricator of the tilting cylinder foot pin (1 lubricator).
- 4 - Lubricator of the tilting cylinder head pin (1 lubricator).
- 5 - Lubricator of the lifting cylinder foot pin (1 lubricator).
- 6 - Lubricator of the lifting cylinder head pin (1 lubricator).
- 7 - Lubricator of the compensating cylinder foot pin (1 lubricator).
- 8 - Lubricator of the compensating cylinder head pin (1 lubricator).

FRONT AND REAR WHEEL REDUCTION GEAR PIVOTS

- 9 - Lubricators of the wheel reduction gear pivot pins (8 lubricators).

AXLE OSCILLATION

- 10 - Front axle oscillation lubricators (2 lubricators).
- 11 - Rear axle oscillation lubricators (2 lubricators).

FRAME LEVELING

(MT 1135/1335 ...)

- 12 - Lubricator of the tilting corrector cylinder foot pin (2 lubricator).
- 13 - Lubricator of the tilting corrector cylinder head pin (1 lubricator).

STABILIZERS

(MT 1135/1335 ...)

- 14 - Lubricators of the stabilizer cylinder foot pin (2 lubricators).
- 15 - Lubricators of the stabilizer cylinder head pin (2 lubricators).
- 16 - Lubricators of the stabilizer pins (2 lubricators).

OSCILLATION LOCK

(MT 1335 ...)

- 17 - Oscillation lock cylinder foot pin lubricator (1 lubricator).
- 18 - Oscillation lock cylinder head pin lubricator (1 lubricator).

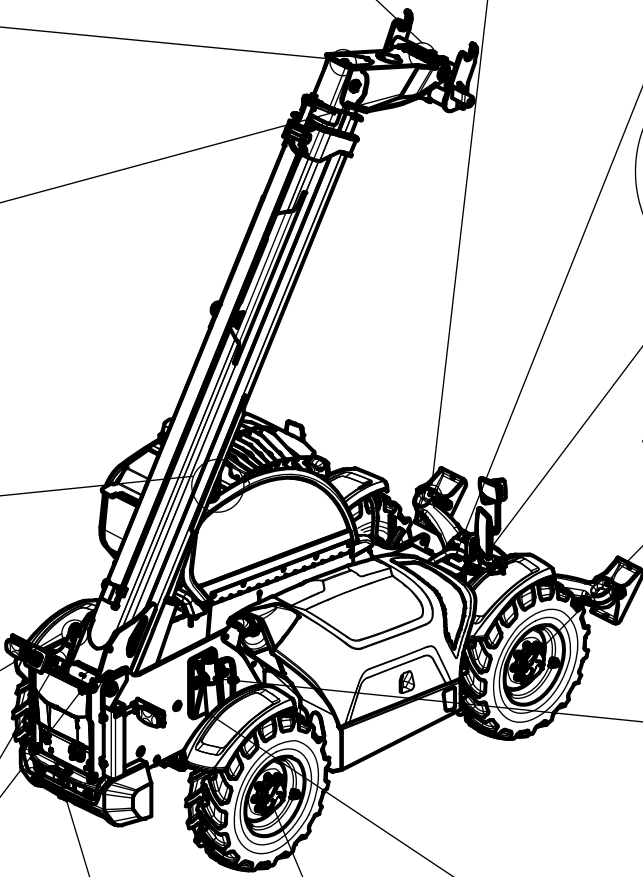
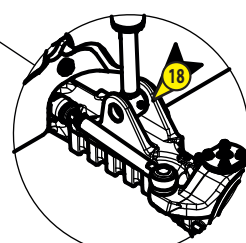
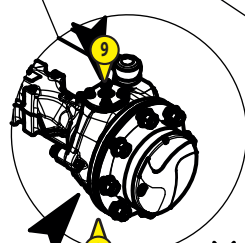
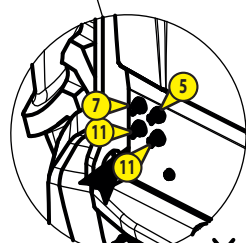
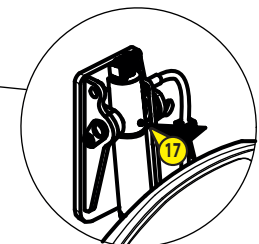
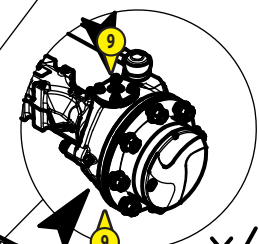
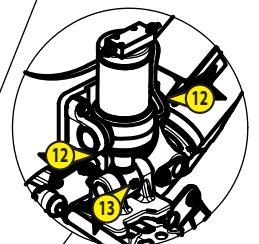
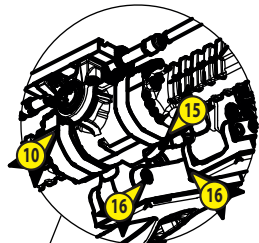
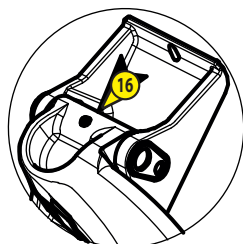
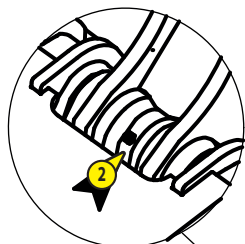
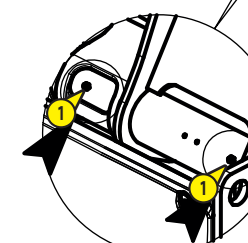
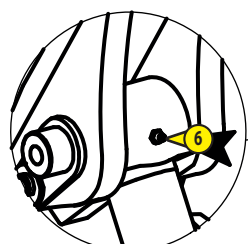
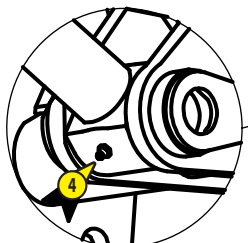
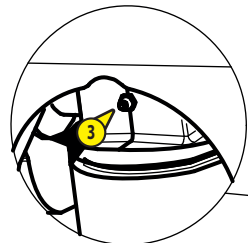

x2

x4

x4

x4



52753103



CHECK

Countdown before "stationary machine" exhaust regeneration

Depending on the countdown before the next regeneration, you can evaluate and, if necessary, perform a regeneration during the periodic 500-hour service (➔ 3 - MAINTENANCE: OCCASIONAL MAINTENANCE).

- Press the button  to display the "PREFERENCES" menu.
- Press the button  to select from the menus and sub-menus.

ENGINE > REGENERATION

- Press the button  to display the countdown before next regeneration screen (700h => 0h).

CHECK

Alternator belt tension

⚠ IMPORTANT ⚠

If the compressor belt has to be changed, check the tension again after the first 20 hours of operation.

- Open the engine hood.
- Remove the protective panel 1.
- Check the belt for signs of wear and cracks and change if necessary.
- Check the tension between the crankshaft and alternator pulleys.
- Under a normal pressure exerted with the thumb (45 N), the clearance should be approximately 10 mm.
- Adjust if necessary.
- Loosen the screws 2 and 3 by two to three thread turns.
- Tighten the belt to the tension required. MT 7/9/11/13 75D...
- Tighten the screw 4 to tighten the belt to the tension required. MT 13 100D...
- Retighten the screws 2 (tightening torque 22,1 lb-pi (30 N.m)) and the screw 3 (tightening torque 30,9 lb-pi (42 N.m)).
- Refit the protective casing 1.

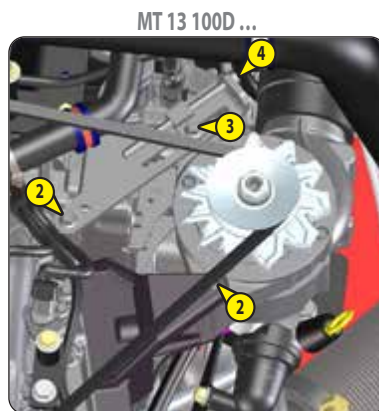
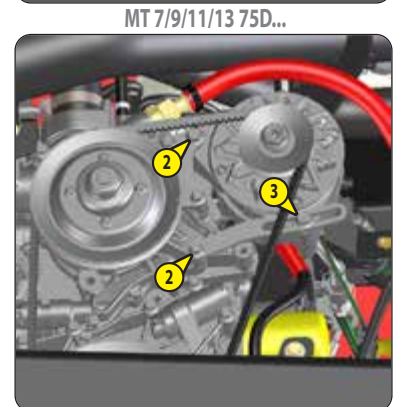
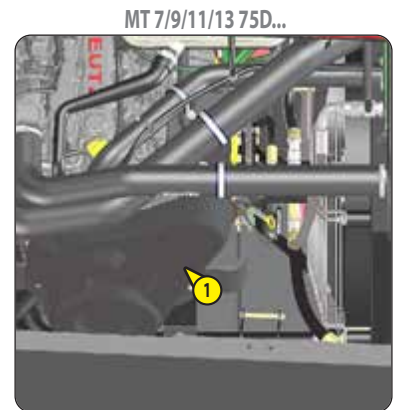

CHECK

Compressor belt condition (Air conditioning option)

- Open the engine hood.
- Remove the protective casing 1.
- Check the belt for signs of wear and cracks and change if necessary.
- Refit the protective casing 1.
- Close the engine hood.



CHECK

Hydraulic oil

MANITOU offers a hydraulic fluid analysis kit which might make it possible to delay the recommended deadline in the periodic maintenance schedule (2,000 hours). In this case, we recommend an analysis of the hydraulic oil every 500 hours of service.

The oil analysis kit also makes it possible to confirm the oil quality so as to obtain a deadline of 2,000 hours for specific uses causing constraints on the hydraulic circuit: extreme environmental conditions, use of the attachments with a very high hydraulic flow rate (such as a sweeper, or a concrete mixer).

- Order an oil analysis kit from your dealer.
- Upon receiving the kit, take a sample of oil and follow the instructions shown on the kit.
- According to the results, keep the analysis report or replace the hydraulic fluid.



CHECK

Fork wear *

** Consult your dealer.*

CHECK

Tightening of 12 V electrical connections

⚠ IMPORTANT ⚠

Electrical accreditation may be required for this maintenance operation: comply with local, governmental and national regulations in force.

Disconnect the battery before working on the electrical system.

Make sure that the positive terminals cannot come into contact with the negative terminals or the metallic parts of the machine at any time.

After each job, make sure that the electrical component protection systems are put back (covers, caps, grommets, etc.).

- Take off the battery cover.
- Open the engine hood.
- Check the condition of the 12 V electrical wires:
 - Between the battery and the diesel engine.
 - Between the battery and the battery cut-off.
 - Between the battery cut-off and the fuse box.
 - Between the fuse box and the starter.
 - Between the battery cut-off and the alternator.
 - Between the fuse box and the fuse/relay box.
- Check the tightening of the 12 V electrical connections:
 - On the battery.
 - On the diesel engine.
 - On the battery cut-off.
 - On the fuse box.
 - On the fuse/relay box.
 - On the starter
 - On the alternator.
- Close the engine hood.
- Put the battery cover back on.



REPLACE

Gearbox oil filter

⚠ IMPORTANT ⚠

Raise the boom and place the boom safety wedge on the rod of the lifting cylinder (<1 - INSTRUCTIONS AND SAFETY RECOMMENDATIONS: MACHINE MAINTENANCE INSTRUCTIONS).

Tighten the gearbox oil filter by hand only and lock the filter in place by a quarter turn.

- Remove the cover plate 1.
- N.B.: When removing cover plates and hatches, clean the surrounding area and remove any accumulations of flammable materials.
- Unscrew and discard gearbox oil filter 2.
 - Carefully clean the filter head with a clean, lint-free cloth.
 - Lightly oil the new seal and fit it to the filter.
 - Fill up the new gearbox oil filter with new oil.
 - Refit the filter, making sure that the seal is correctly positioned and tightened.
 - Refit cover plate 1.

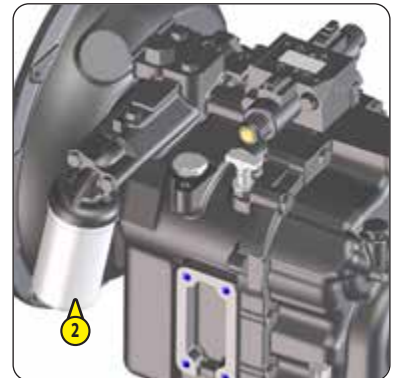

REPLACE

Engine oil

REPLACE

Engine oil filter

Set the machine on a horizontal surface, leave the engine idling for a few minutes and then switch it off.

DRAINING THE OIL

- Open the engine hood.
- Remove the access panel 1. MT 7/9/11/13 75D...
- Remove the access panel 2.

N.B.: When removing cover plates and hatches, clean the surrounding area and remove any accumulations of flammable materials.

- Place a container under drain fitting 3 and unscrew the fitting.
- Take drain hose 4.
- Fully screw the hose onto the drain fitting 3.
- Remove the filler plug 5.

REPLACEMENT OF THE FILTER

- Unscrew and discard the oil filter 6, together with its seal.
- Clean the filter bracket with a clean, lint-free cloth.
- Lightly oil the seal before refitting the new oil filter on its bracket (tightening torque 11,8 lb-pi ± 1 lb-pi (16 N.m ± 1 N.m)).

FILLING WITH OIL

- Remove, clean and refit drain hose 4.
- Refit and tighten the drain fitting 3.
- Fill up with new oil through the filler hole 5.
- Wait a few minutes to allow the oil to flow into the sump.
- Start the engine and let it run for a few minutes.
- Check for possible leaks from the drain plug and the oil filter.
- Stop the engine, wait a few minutes and check the correct level between the two marks on the dipstick 7.
- Top up the level, if necessary.
- Refit the access panel 1. MT 7/9/11/13 75D...
- Refit the access panel 2.
- Close the engine hood.

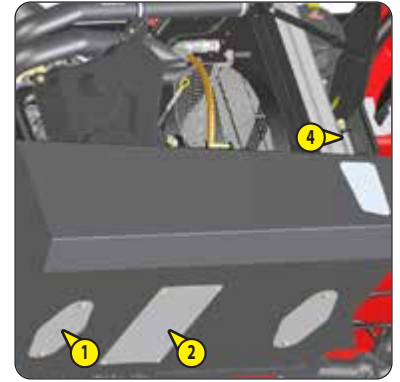

MT 7/9/11/13 75D...

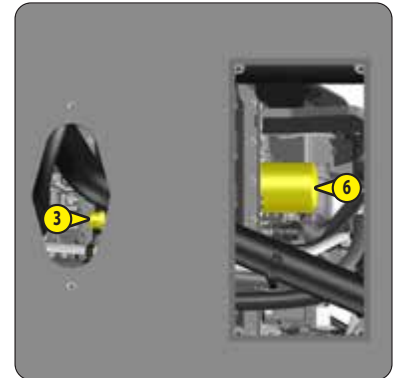

MT 13 100D ...

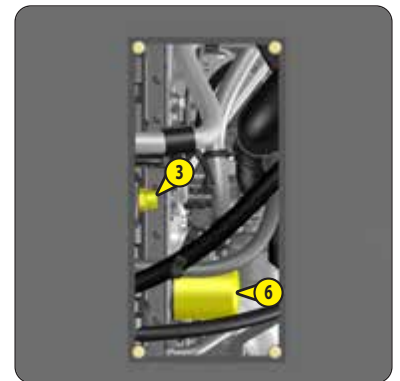

MT 7/9/11/13 75D...

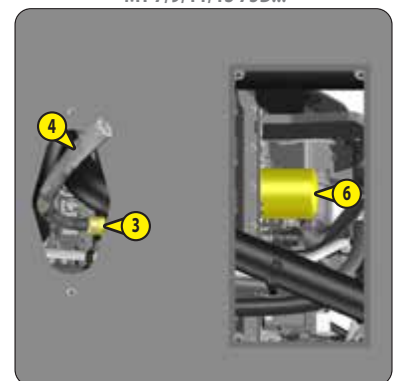

MT 13 100D ...

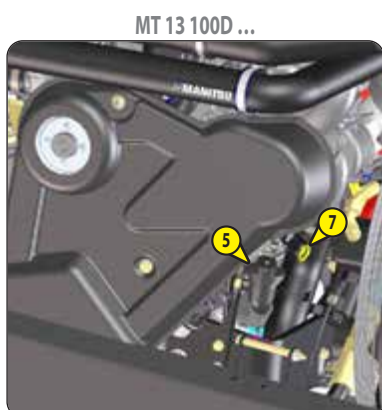
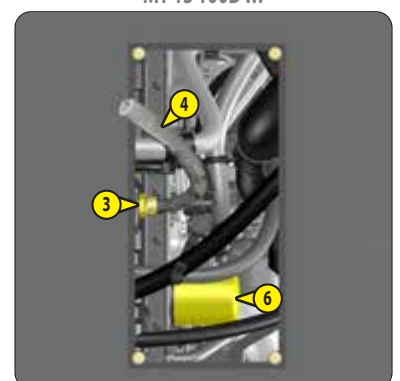

MT 13 100D ...

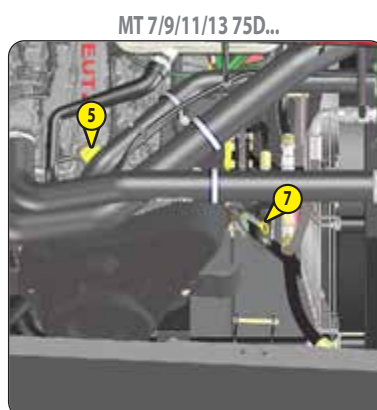

MT 7/9/11/13 75D...

REPLACE**Front axle differential oil****REPLACE****Rear axle differential oil**

Place the machine on level ground with the engine stopped and the differential oil still warm.

- Place a container under drain plugs 1 and unscrew them.
- Remove the level plug 2 and the filler cap 3.
- Refit and tighten the drain plugs 1 (tightening torque 30,2 lb-pi ± 5,1 lb-pi (41 N.m ± 7 N.m)).
- Fill up with oil through the filler hole 3.
- The level is correct when the oil level is flush with the edge of opening 2.
- Check for any possible leaks at the drain plugs.
- Refit and tighten level plug 2 (tightening torque 30,2 lb-pi ± 5,1 lb-pi (41 N.m ± 7 N.m)) and filling plug 3 (tightening torque 30,2 lb-pi ± 5,1 lb-pi (41 N.m ± 7 N.m)).
- Repeat this operation for the rear axle differential.

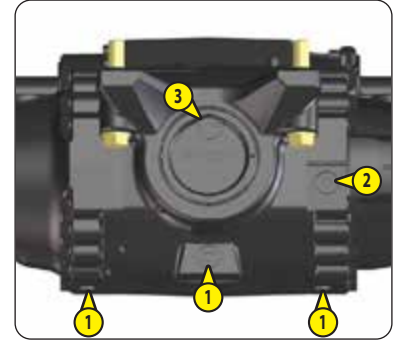
**REPLACE****Front wheel reducer oil****REPLACE****Rear wheel reducer oil**

Place the machine on level ground with the engine stopped and the reducer oil still warm.

- Drain and change the oil of each wheel reduction gear.
- Place drain plug 1 in position A.
- Place a container under the drain plug and unscrew the plug.
- Let the oil drain fully.
- Place the drain port in position B, i.e. in a level port.
- Fill up with oil through the level hole 1.
- The level is correct when the oil level is flush with the edge of the hole.
- Refit and tighten the drain plug (tightening torque 30,2 lb-pi ± 5,1 lb-pi (41 N.m ± 7 N.m)).

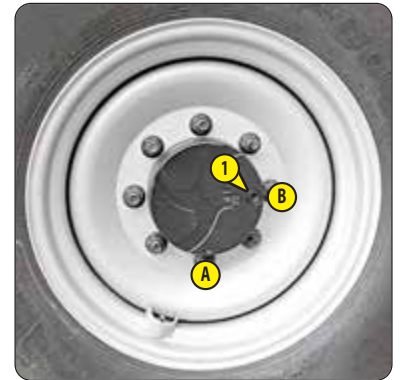
**REPLACE****Hydraulic fluid tank breather cap**

- Remove the lock 1.
- Replace the breather cap 2 with a new one.
- Refit the latch 1.

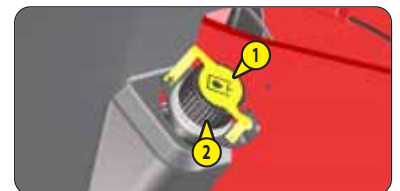
**REPLACE****Cab ventilation filters****EXTERNAL CAB VENTILATION FILTER**

- Remove protective casing 1 using the ignition key.
- Remove the cab ventilation filter 2 and replace it with a new one.
- Refit the protective casing.

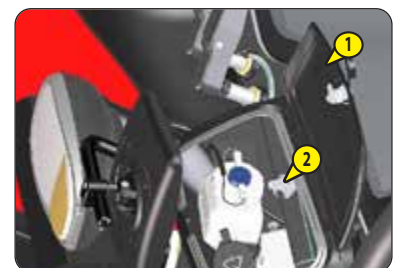
**INTERNAL CAB VENTILATION FILTER**

- Remove the protective grid 3.
- Remove the cab ventilation filter 4 and replace it with a new one.
- Refit the protective grid.



🔧 1000H - PERIODIC MAINTENANCE - EVERY 1000 HOURS OF SERVICE OR EVERY 2 YEARS

ALSO CARRY OUT THE PERIODIC MAINTENANCE FOR 500 HOURS OF SERVICE.

CHECK

Seat belt

⚠️ IMPORTANT ⚠️

*Under no circumstances must the machine be used if the seat belt is defective (fixing, locking, cuts, tears, etc.).
Immediately repair or replace the seat belt.*

SEAT BELT WITH TWO ANCHORING POINTS

- Check the following points:
 - Fixing of the anchoring points on the seat.
 - Cleanness of the strap and the locking mechanism.
 - Triggering of the locking mechanism.
 - Condition of the strap (cuts, curled edges).

REELED SEAT BELT WITH TWO ANCHORING POINTS

- Check the points listed above together with the following points:
 - The correct winding of the belt.
 - Condition of the reel guards.
 - Roller locking mechanism when the strap is given a sharp tug.

N.B.: Replace the seat belt after an accident.

BLEED

Fuel tank

REPLACE

Fuel tank breather

Set the machine on level ground with the engine stopped.

⚠️ IMPORTANT ⚠️

Do not smoke or approach with a flame during this operation.

Never attempt to carry out welding or any other operation by yourself, as this could cause an explosion or a fire.

- Inspect the parts of the fuel circuit and the tank liable to leak, both visually and by touch.
- In the event of a leak, contact your dealer.
- Remove the protective panel 1.
- Place a container under drain plug 2 and unscrew the plug.
- Remove the filler plug 3.
- Rinse with ten litres of clean diesel through the filler port.
- Refit and tighten the drain plug 2 (tightening torque 59 lb-pi ± 5,9 lb-pi (80 N.m ± 8 N.m)).
- Unscrew the breather 4 and replace it with a new one (tightening torque 3,6 lb-pi ± 1,4 lb-pi (5 Nm ± 2 N.m)).
- Fill the fuel tank with clean diesel filtered through the filler port.
- Refit the filler plug 3.
- Refit the protective casing 1.



REPLACE

Coolant

These operations are to be carried out as necessary or every 2 years at the beginning of winter. Place the machine on level ground with the engine stopped and cold.

⚠ IMPORTANT ⚠

The engine does not contain any anti-corrosion elements and must be filled throughout the year with a mixture containing 25% ethylene glycol-based antifreeze.

DRAINING THE LIQUID

- Open the engine hood.
- Remove access panel 1.

N.B.: When removing cover plates and hatches, clean the surrounding area and remove any accumulations of flammable materials.

- Place a container under drain fitting 2 and unscrew the fitting.
- Take drain hose 3.
- Fully screw the hose onto the drain fitting 2.
- Remove the filler plug 4 from the expansion tank and fully open the heating control.
- Let the cooling circuit empty entirely while ensuring that the ports do not get clogged.
- Check the condition of the hoses as well as the fastening devices and change the hoses if necessary.
- Rinse the circuit with clean water and use a cleaning agent if necessary.

FILLING WITH COOLANT

- Refit and tighten the radiator drain plug 2.
- Slowly fill the circuit with coolant up to the MAX level of the expansion tank 5 through the filler hole.
- Refit the filler plug 4.
- Run the engine at idle for a few minutes.
- Check for any possible leaks.
- Refit access panel 1.
- Check the level and top up if necessary.

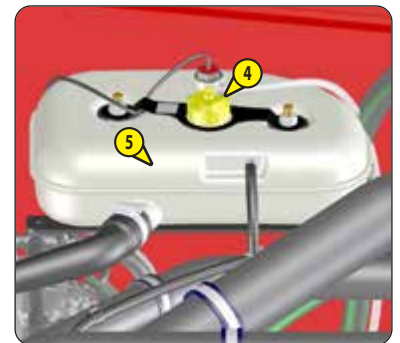
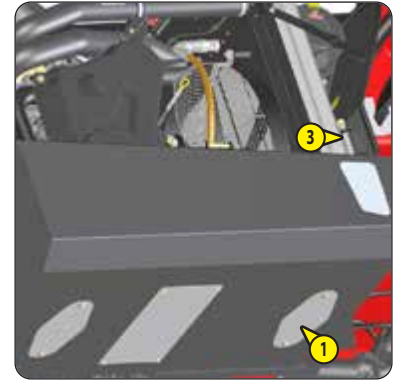

REPLACE

Dry air filter cartridge

In case of use in a heavily dust laden atmosphere, there are pre-filtration cartridges (contact your dealer). Also, the checking and cleaning periodicity of the cartridge must be reduced (up to 250 hours in a very dusty atmosphere and with pre-filtration).

⚠ IMPORTANT ⚠

*Change the cartridge in a clean location, with the engine stopped.
Never operate the machine with a cartridge removed or damaged.*

- Open the engine hood.
- Remove the cover 1.
- Gently remove the cartridge 2 to reduce dust falling as far as possible.
- Leave the safety cartridge in place.
- Carefully clean the following parts with a damp, clean lint-free cloth.
 - The inside of the filter and cover.
 - The inside of the filter inlet hose.
 - The gasket surfaces in the filter and in the cover.
- Check pipes and connections between the air filter and the engine and the connection and state of the clogging indicator on the filter.
- Before fitting, check the condition of the new cartridge.
- Insert the cartridge in the filter axis and push the cartridge pressing against the outer edge and not in the center.
- Reassemble the cover, guiding the valve downwards.



REPLACE

Fuel pre-filter

⚠ IMPORTANT ⚠

*Carefully clean the outside of the pre-filter and its holder, to prevent dust from getting into the system.
Tighten the fuel filter by hand only and lock in place by a quarter turn.*

- Switch on the machine's ignition.
- Open the engine hood.
- Disconnect electrical wiring harness 1 from the fuel pre-filter.
- Place a hose on the drain plug 2 and the other end in a container.
- Unscrew the drain plug 2 by two turns.
- Open bleed screw 3.
- Retighten bleed screw 3 once the pre-filter is emptied.
- Loosen pre-filter 4 and discard it, together with its seal.
- Clean the inside of the pre-filter head using a brush impregnated with clean diesel oil.
- Refit a pre-filter and a new seal lubricated with clean diesel beforehand.
- Reconnect electrical wiring harness 1 on the fuel pre-filter.
- Replace the fuel filter.

MT 7/9/11/13 75D...

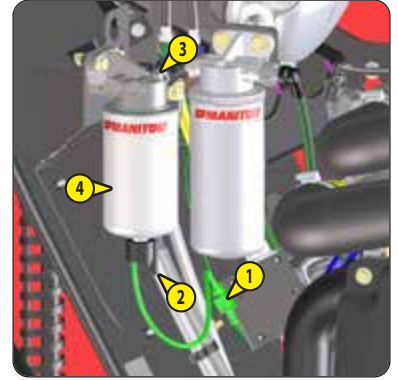

MT 13 100D ...

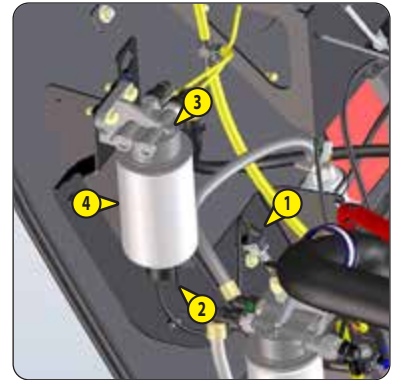

REPLACE

Fuel filter

⚠ IMPORTANT ⚠

Carefully clean the outside of the filter and its holder, to prevent dust from getting into the system.

- Unscrew and discard the fuel filter 1.
- Clean the inside of the filter head using a brush immersed in clean diesel oil.
- Refit a filter and a new seal lubricated with clean diesel beforehand.
- Tighten the filter, making sure that the seal is correctly positioned (tightening torque 8,1 lb-pi ±0,7 lb-pi (11 N.m ±1 N.m)).
- Open the bleed screw 3 of the fuel pre-filter and the bleed screw 2 of the fuel filter.
- Switch on the machine's ignition, and close the bleed screws as soon as the diesel flows with no air.

MT 7/9/11/13 75D...

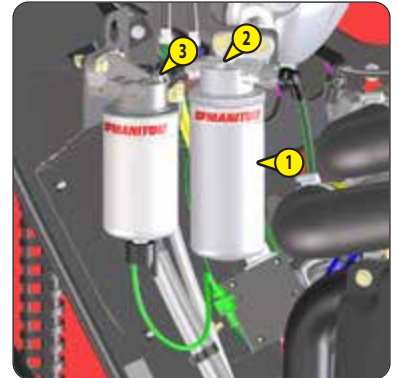

MT 13 100D ...

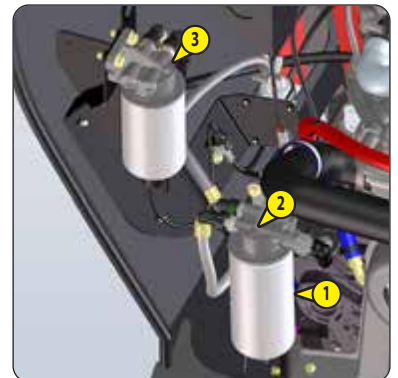

REPLACE

Feed pump filter "DEF"

MT 13 100D ...

Set the machine on level ground with the engine stopped.

⚠ IMPORTANT ⚠

*Diesel exhaust fluid is corrosive: protect the bodywork and wear personal protective equipment (gloves and goggles).
Carefully clean the outside of the fuel filter, to prevent dust from getting into the system.*

- Switch off the machine's ignition and wait for the pump 1 to stop.
- Unscrew the cover 2 of pump 1, remove the element 3 and discard.
- Insert the extraction tool 4 (provided with the new filter) into the filter 5 until a click is heard or felt.
- Pull the tool to extract and discard the assembly.
- Lightly oil the cover joint with clean engine oil.
- Replace with a new filter and compensation element in the pump and screw on the cover 1 (tightening torque 16,9 lb-pi (23 N.m)).

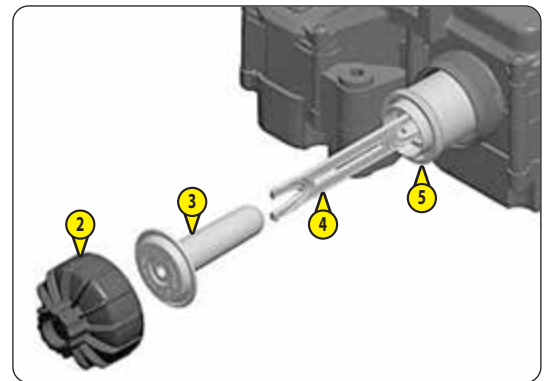
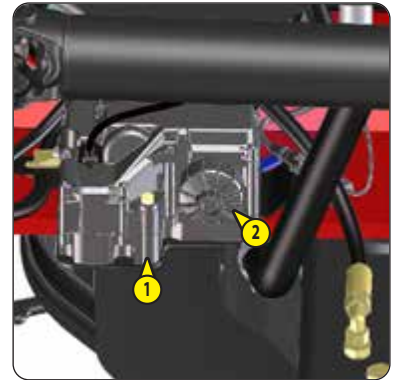

REPLACE

Tank breather "DEF"

- Remove access panel 1.
- Unscrew the breather 2 and replace it with a new one (⇐ FILTER CARTRIDGES AND BELTS).
- Refit access panel 1.



REPLACE

Tank filler strainer "DEF"

MT 13 100D ...

- Remove the filler plug 1.
- Unlock the strainer 2 and replace with a new one.
- Remove the filler plug 1.



REPLACE

Alternator belt

⚠ IMPORTANT ⚠

Check the belt tension again after the first 20 hours of operation.

- Open the engine hood.
- Remove the protective casing 1.
- Loosen the screws 2 and 3 by two to three thread turns.
- Undo the screw 4 to free the belt 5. MT 13 100D...
- Remove the belt 5 and replace with a new one.
- Tighten the belt to the tension required. MT 7/9/11/13 75D...
- Tighten the screw 4 to obtain the required tension. MT 13 100D...
- Under a normal pressure exerted with the thumb 30,9 lb-pi (45 N.m), the clearance should be approximately 10 mm.
- Retighten the screws 2 (tightening torque 22,1 lb-pi (30 N.m)) and the screw 3 (tightening torque 33,1 lb-pi (42 N.m)).
- Refit the protective casing 1.

MT 7/9/11/13 75D...

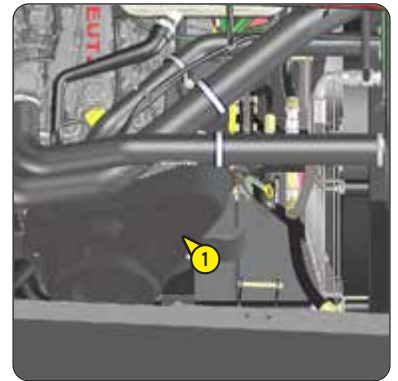

MT 7/9/11/13 75D...

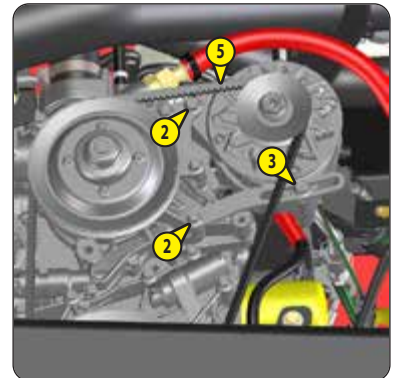

MT 13 100D ...



MT 13 100D ...

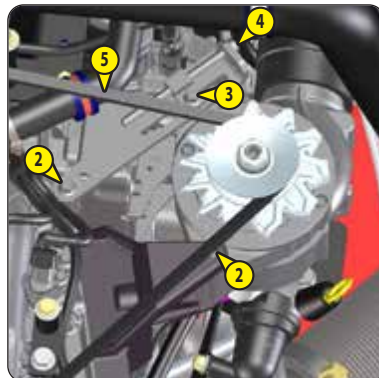

REPLACE

Gearbox oil

CLEAN

Gearbox sump strainer

Place the machine on level ground with the engine stopped and the transfer box oil still warm.

⚠ IMPORTANT ⚠

Raise the boom and place the boom safety wedge on the rod of the lifting cylinder (↖ 1 - INSTRUCTIONS AND SAFETY RECOMMENDATIONS: MACHINE MAINTENANCE INSTRUCTIONS).

DRAINING THE OIL

- Place a container under drain plug 1 and under cover 2 and unscrew the drain plug.
- Remove the cover plate 3.

N.B.: When removing cover plates and hatches, clean the surrounding area and remove any accumulations of flammable materials.

- Remove the gage 4 and unscrew the filler plug 5.

CLEANING THE SUCTION STRAINER

- Remove cover 2 and set aside the O-ring joint and sealing washer.
- Allow the rest of the oil to drain away.
- Remove and clean the strainer using a compressed air jet.
- Clean the magnetic section on the plate.
- Refit the assembly and tighten up plate 2 (tightening torque 17,7 lb-pi ± 4,4 lb-pi (24 N.m ± 6 N.m)).

FILLING WITH OIL

- Refit and tighten the drain plug 1 (tightening torque 28,7 lb-pi ± 3,6 lb-pi (39 N.m ± 5 N.m)).
- Fill up with new oil through the filler port 5 and refit the plug.
- Start the engine and let it run for a few minutes.
- Check any possible leaks from the drain plug or cover.
- Stop the engine, and within 5 minutes of the engine being stopped, check the correct level between the MIN and MAX marks on the dipstick 4.
- Top up the level, if necessary.
- Refit cover plate 3.

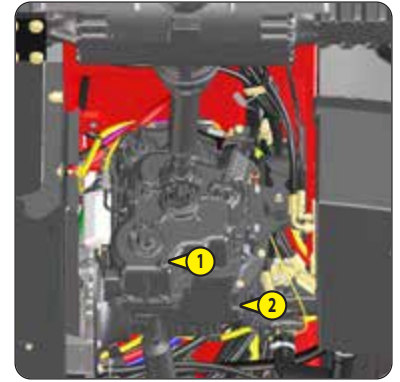

REPLACE

Hydraulic return oil filter cartridge

Place the machine on horizontal ground with the engine stopped and remove the pressure from the circuits by acting on the hydraulic controls.

⚠ IMPORTANT ⚠

Thoroughly clean the outside of the filter and its surroundings before any operation to prevent any risk of polluting the hydraulic system.

- Remove the protective casing 1.
- Unscrew the fastening screws of the cover 2.
- Wait a few moments while the oil flows into the tank.
- Remove the hydraulic return oil filter cartridge 3 and replace with a new one.
- Make sure that the cartridge is correctly positioned and refit the cover 2 with its screws.
- Refit the protective casing 1

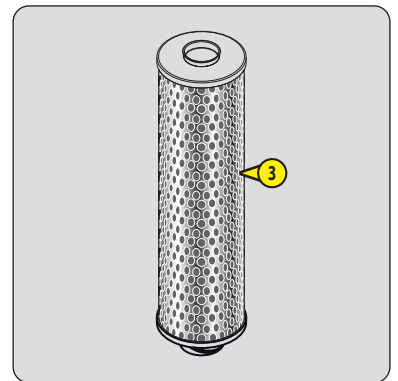

CHECK	Engine silent blocks *
CHECK	Gearbox silent blocks *
CHECK	Gear box controls *
CHECK	Brake system pressure *
CHECK	Boom pad wear *
CHECK	Condition of wiring harnesses and cables *
CHECK	Lights and signals *
CHECK	Warning indicators *
CHECK	Condition of rear-view mirrors *
CHECK	Cab structure *
CHECK	Chassis structure *
CHECK	Attachment mounting system *
CHECK	Condition of attachments *
REPLACE	Brake fluid *
BLEED	Brake circuit *
ADJUST	Brake *

*** Consult your dealer.**

🔄 2000H - PERIODIC MAINTENANCE - EVERY 2000 HOURS OF SERVICE OR EVERY 4 YEARS

ALSO PERFORM THE 500 HOUR AND 1000 HOUR PERIODIC MAINTENANCE.

CHECK

Wheel nut tightening torque

- Check the tightening torque of the wheel nuts with a torque wrench:
 - Front wheels = 464,6 lb-pi ± 69,3 lb-pi (630 N.m ± 94 N.m)
 - Rear wheels = 464,6 lb-pi ± 69,3 lb-pi (630 N.m ± 94 N.m)

CLEAN

Air conditioning (OPTION) *

CLEANING CONDENSER AND EVAPORATOR COILS

CLEANING CONDENSATE TRAY AND RELIEF VALVE

COLLECTING COOLANT TO REPLACE DRIER FILTER

REFILLING WITH COOLANT AND CHECKING THE THERMOSTATIC CONTROL AND PRESSURE SWITCHES

N.B.: When opening the evaporator unit, remember to replace the cover seal.

⚠️ IMPORTANT ⚠️

NEVER TRY TO REPAIR ANY FAULTS YOURSELF.

WHEN REFILLING CIRCUITS, ALWAYS REFER TO A DEALER WHO HAS THE CORRECT SPARE PARTS AND THE TECHNICAL KNOWLEDGE AND TOOLS REQUIRED.

In any of the following circumstances, call a doctor.

If inhaled, take the victim to fresh air.

If there is contact with the skin, wash immediately with plenty of water.

If there is frostbite, apply a sterile dressing.

If there is contact with the eyes, rinse with clear water for 15 minutes.

IMPORTANT INFORMATION REGARDING THE COOLANT USED

- This product contains fluorinated greenhouse gases covered by the Kyoto Protocol.
 - Coolant type: R134A; it is colorless and odorless and heavier than air. Its GWP (Global Warming Potential) is 1430.
 - Do not allow the gases to escape into the atmosphere. Do not open the system under any circumstances, as this could cause refrigerant to escape.
- The compressor has a fluid level gage; never unscrew this gage because it would depressurize the system. The fluid level should only be checked when draining the system.

** Consult your dealer.*



REPLACE

Dry air filter safety cartridge

⚠ IMPORTANT ⚠

The safety cartridge replacement frequency is given for information only. It must be changed every second time the dry air filter cartridge is changed.

- For the dismantling and refitting of the cartridge ($\leq 1000\text{H}$: REPLACE Air filter cartridge).
- Carefully remove the dry air filter safety cartridge 1 to reduce dust fall as much as possible.
- Clean the gasket surface on the filter with a damp, clean lint-free cloth.
- Check the condition of the new safety cartridge before fitting.
- Insert the cartridge in the filter axis and push the cartridge pressing against the outer edge and not the center.



REPLACE

Angle gear box oil

Place the machine on level ground with the engine stopped and the angle gearbox oil still warm.

- Place a container under the drain plug 1 and unscrew the plug.
- Remove the level plug 2 and the filler cap 3.
- Refit and tighten the drain plug 1 (tightening torque 22,1 lb-pi \pm 3,6 lb-pi (30 N.m \pm 5 N.m)).
- Fill up with oil through the filler hole 3.
- The level is correct when the oil level is flush with the edge of opening 2.
- Refit and tighten the level plug 2 (tightening torque 22,1 lb-pi \pm 3,6 lb-pi (30 N.m \pm 5 N.m)).
- Refit and tighten the filler plug 3 (tightening torque 22,1 lb-pi \pm 3,6 lb-pi (30 N.m \pm 5 N.m)).
- Check for any possible leaks at the drain plug.



REPLACE

Hydraulic oil

REPLACE

Hydraulic oil tank suction strainer

REPLACE

Fan reversal filter (OPTION)

Place the machine on level ground with the engine shut down and the boom retracted and lowered as far as possible.

⚠ IMPORTANT ⚠

Before any intervention, thoroughly clean the area surrounding the drain plug and the suction strainer on the hydraulic tank.

Use a clean container and funnel and clean the underside of the oil drum before filling.

DRAINING THE OIL

- Place a container under drain plugs 1 and unscrew them.
- Remove the lock 2 of the filler cap 3.
- Remove the filler plug 3.

STRAINER REPLACEMENT

- Disconnect hose 4.
- Unscrew the suction strainer 5 and replace it with a new one (tightening torque 18,4 lb-pi ± 1,4 lb-pi (25 N.m ± 2 N.m)) making sure the seal is in the correct position.
- Refit the hose 4.

REPLACING THE FAN REVERSAL FILTER (OPTION)

⚠ IMPORTANT ⚠

Be careful to mount the filter in the same direction as the arrow on the filter.

- Unscrew the filter 6 and replace it with a new one.

FILLING WITH OIL

- Refit and tighten the drain plugs 1 (tightening torque 44,2 lb-pi ± 6,6 lb-pi (60 N.m ± 9 N.m)).
- Fill up with oil through the filler hole 3.
- Observe the oil level on dipstick 7. The oil must be level with the red dot.
- Check for any possible leaks at the drain plug.
- Refit the filler cap 3 and its lock 2.

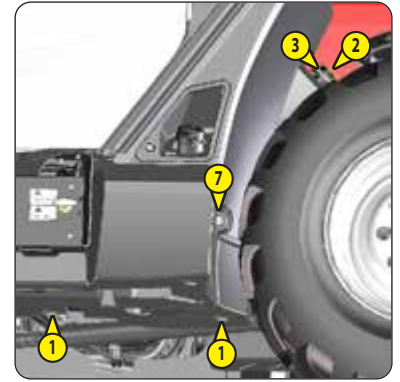

CHECK	Radiator *
CHECK	Water pump and thermostat *
CHECK	Alternator and starter *
CHECK	Turbocharger *
CHECK	Transmission pressures *
CHECK	Steering *
CHECK	Steering swivel joints *
CHECK	Condition of boom assembly *
CHECK	Bearings and bushings of the boom *
CHECK	Condition of hoses and flexible pipes *
CHECK	Condition of cylinders (leakage, rods) *
CHECK	Hydraulic circuit pressures *
CHECK	Chassis bearings and bushings*
REPLACE	Compressor belt (Air Conditioning OPTION) *

** Consult your dealer.*

Clean any traces of fuel, oil or grease from the machine or at least the area in question before carrying out any work.

EXTERIOR WASHING

- Close and lock all accesses to the machine (doors, windows, cowls, etc.).
- When washing with a high pressure cleaner, avoid the hinges and electrical components and connections.
- If necessary, protect components susceptible to damage, particularly electrical components and connections and the exhaust outlet, against penetration of water, steam or cleaning agents.
- After washing, leave the machine to dry in the open air and do not park inside a building.

INTERIOR WASHING

- Avoid cleaning the engine, the harnesses, the electrical components and parts with sensitive seals (e.g. universal joint cross-piece) with a high pressure cleaner. Clean with compressed air instead.
- Clean any accumulation of flammable materials near to heat sources and electrical components.
- Special attention should be paid to all the areas of the machine where these high-risk materials are likely to accumulate (e.g. engine compartment, under the boom, above the axles, etc.).

CLEAN

"Stationary machine" exhaust regeneration

⚠ IMPORTANT ⚠

If you are performing regeneration during the periodic 500-hour service, do the regeneration before replacing the engine oil.

- Park the machine in a safe and adequately ventilated place.
- Check the following points:
 - stabilizers up,
 - forward/reverse selector in neutral,
 - parking brake applied,
 - no action on the hydraulic control joystick,
 - boom in transport position,
 - idling speed,
- Check that the fuel level is sufficient.
- Start the machine and run the engine for a few minutes to bring it up to its normal operating temperature.



- Press the top of button  and hold for at least two seconds to launch exhaust regeneration. The indicator lamp comes on fixed and the engine speed increases, confirming the start of regeneration.
- The length of the exhaust regeneration procedure varies (between 40 and 50 minutes).

⚠ IMPORTANT ⚠

Exhaust regeneration must only be stopped if absolutely necessary.

Regeneration stops automatically if the operator:

- *activates the hydraulic control joystick,*
- *engages forward or reverse gear,*
- *switches off the engine,*
- *presses switch 1.*

- When regeneration has finished, the indicator lamp  goes out and the countdown before next regeneration screen returns to 700 hours (700h => 0h).

REPLACE

Wheels

⚠ IMPORTANT ⚠

*In the event of a wheel being changed on the public highway,
Secure the machine's environment:*

- If possible, stop the machine on firm, level ground.
- Stop the machine (⚠ 1 - SAFETY INSTRUCTIONS: DRIVING INSTRUCTIONS UNLADEN AND LADEN).
- Switch on the hazard warning lights.
- Immobilize the machine in both directions on the axle opposite to the wheel to be changed.
- Loosen the wheel nuts by a few turns.
- Place the jack 1 under the sticker (⚠ 2).
- Lift the wheel until it leaves the ground.
- Place the safety prop 2 under the axle.
- Completely unscrew the wheel nuts and remove them.
- Replace the wheel with the new one.
- Hand-tighten the wheel nuts.
- Remove the safety support prop and lower the machine using the jack.
- Tighten the wheel nuts to the prescribed torque value (⚠ 2000H - PERIODIC MAINTENANCE - EVERY 2,000 HOURS OF SERVICE OR EVERY 4 YEARS) using a torque wrench.



REPLACE

Battery

⚠ IMPORTANT ⚠

Switch off the ignition with the key, wait 30 seconds, then operate the battery cut-off.

Wait 5 minutes before disconnecting the battery, this is required in order to purge the Diesel Exhaust Fluid "DEF" system.

Handling and servicing a battery can be dangerous. Take the following precautions:

- Wear protective goggles.
- Keep the battery horizontal.
- Never smoke or work near a naked flame.
- Work in a well-ventilated area.

- In the event of electrolyte being spilled onto the skin or splashed in the eyes, rinse thoroughly with cold water for 15 minutes and call a doctor.

- Remove the protective casing 1.
- Change the battery 2.



ADJUST

Front headlights

RECOMMENDED SETTING

(according to standard ECE-76/756 76/761 ECE20)

Adjustment of -2 % of the dipped beam harness relative to the horizontal axis of the headlight.

ADJUSTMENT PROCEDURE

- Place the unladen machine in the transport position and perpendicular to a white wall on flat, level ground.
- Check the tire pressures (≤ 2 - DESCRIPTION: TIRES).
- Put the gearshift lever in neutral.

CALCULATING THE HEIGHT OF THE DIPPED BEAM (H2)

- h1 = Height of the dipped beam in relation to the ground.
- h2 = Height of the adjusted beam.
- l = Distance between the dipped beam and the white wall.

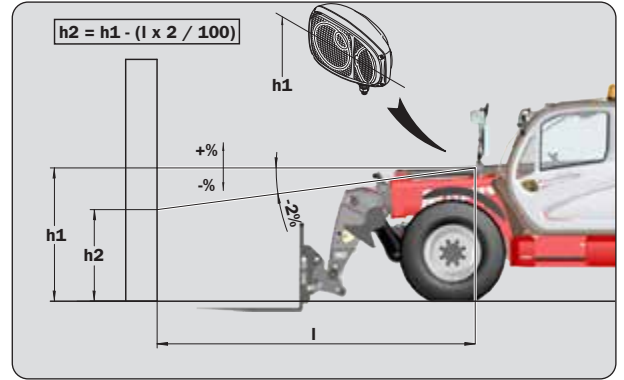

RESET

Longitudinal stability limiter and warning device

Depending on how the machine is used, the device may need to be periodically reset.



This operation can be easily performed by means of the following procedure.

- Provide a fork carrier or a bucket and a load corresponding to at least half the machine's rated capacity.
- Preferably perform the reset when the machine is still cold (before it is used) or ensure that the temperature of the rear axle is not more than 122°F (50 °C).



⚠ IMPORTANT ⚠

Carefully follow the boom positioning instructions.

*When the reset is completed, check the operation of the longitudinal stability limiter and warning device ($\leq 10H$ - DAILY MAINTENANCE OR EVERY 10 HOURS OF SERVICE).
If in doubt, consult your dealer.*

- Place the machine on flat, level ground with the wheels straight.
- Press the button  to display the "PREFERENCES" menu.
- Press the button  to select from the menus and sub-menus.

HYDRAULICS > STABILITY REBALANCING

- Press knob  to confirm.
- Follow the steps described on the information screen (OK = press button ).

⚠ IMPORTANT ⚠

Do not tow the machine at more than 15 km/h, and abide by local traffic regulations.

- Switch on the hazard warning lights.
- Secure the machine in place.
- Place the forward/reverse selector and the gear lever in neutral.
- Release the parking brake.
- Put the towing device in place.
- Remove the chocks.

Since there will be no power steering or hydraulic brake assistance, operate the steering and controls slowly and forcefully. Avoid sudden or jerky movements.

LIFT

Machine

⚠ IMPORTANT ⚠

The surface of the machine's departure/arrival zone must be closed, level and even.

If the departure/arrival zone is a transport vehicle:

- *The transport vehicle must be parked on a level, firm surface.*
- *The wheels of the transport vehicle must be chocked.*

Make sure that the lifting slings are solid enough to take the weight of the machine.

Make sure that the lifting capacity of the crane is sufficient to take the weight of the machine.

Take into account the position of the machine's center of gravity for lifting.

A = 4 ft 11 in (1500 mm)	B = 4 ft 3 in (1300 mm)	MT 735 75D ST5 S1
A = 4 ft 11 in (1500 mm)	B = 4 ft 3 in (1300 mm)	MT 935 75D ST5 S1
A = 4 ft 5 in (1350 mm)	B = 4 ft 9 in (1450 mm)	MT 1135 75D ST5 S1
A = 4 ft 11 in (1500 mm)	B = 4 ft 3 in (1300 mm)	MT 1335 75D ST5 S1
A = 4 ft 11 in (1500 mm)	B = 4 ft 3 in (1300 mm)	MT 1335 100D ST5 S2

Length of the slings respecting the maximum angle of 30°

C = 9 ft 10 in (3000 mm) D = 9 ft 10 in (3000 mm)

- Mark out a wide safety area around the machine.
- Put the machine in transport position (↩ TRANSPORTING THE MACHINE)
- Attach lifting slings to the lifting points 1.
- Attach the lifting slings at 1 point to the crane lifting hook.
- Slowly lift the crane's lifting hook until the lifting slings are slightly taut.
- If necessary, adjust the crane lifting hook to prevent damage and keep the machine level.
- Ensure that there is nobody in the safety zone.
- Lift the machine slowly and move it to the arrival zone.
- Slowly lower the machine until the 4 wheels are in contact with the receiving surface.
- Lower the crane's lifting hook until the lifting slings are no longer taut.
- Detach the lifting slings.

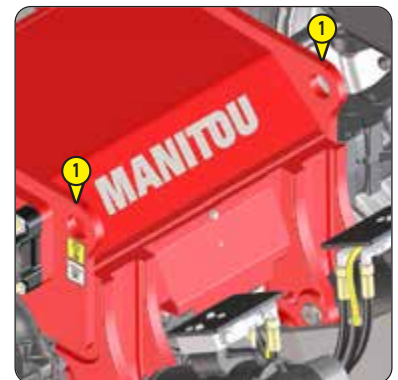
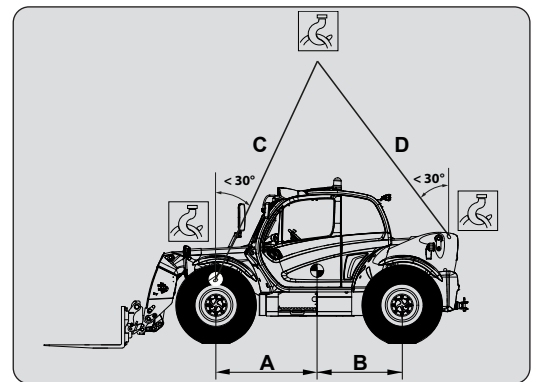

⚠ IMPORTANT ⚠

Check that the safety instructions associated with the transport vehicle have been correctly applied before loading the machine and ensure that the driver of the vehicle has been informed of the dimensional characteristics and total weight of the machine.

Ensure that the transport vehicle has adequate dimensions and load capacity for transporting the machine, \triangleleft SPECIFICATIONS and STICKERS.

Covers must be closed and locked while the machine is being transported.

⚠ IMPORTANT ⚠

The transport vehicle must be parked on a level surface and the wheels must be chocked to prevent it from rolling during loading and unloading of the machine. For machines equipped with a turbo-charged engine, block off the exhaust outlet to avoid rotation of the turbo shaft without lubrication when transporting the vehicle.

The machine must be loaded or unloaded using a winch if the loading ramps are slippery, \triangleleft FREEWHEELING FOR TOWING/WINCHING.

The angle of the loading ramps must not exceed the maximum slope accessible value, \triangleleft SPECIFICATIONS.

The machine must be loaded and unloaded using a crane if the angle of the loading ramps exceeds the maximum slope accessible value, \triangleleft TRANSPORT FOR WINCHING: LIFTING INSTRUCTIONS.

LOADING THE MACHINE ONTO THE TRANSPORT VEHICLE

- Fully retract the telescopic arm.
- Load the machine parallel to the transport vehicle.
- Place the attachment flat on the ground.
- Activate the parking brake.
- Switch off the machine.
- Remove the ignition key.

SECURING THE MACHINE TO THE TRANSPORT VEHICLE

- Fix chocks to the transport vehicle at the front and rear of each of the machine's wheels.
- Fix chocks to the transport vehicle on the inner side of each of the machine's wheels.
- Attach the straps to the machine's anchoring points, \triangleleft STICKERS: ANCHORING POINT.
- Secure the machine, observing the lashing angles (α) and (β) and the resistance (LC) of the straps.

UNLOADING THE MACHINE FROM THE TRANSPORT VEHICLE

- Remove the straps.
- Remove the chocks from the wheels.
- Switch on the machine.
- Raise the telescopic arm.
- Release the parking brake.
- Lower the machine parallel to the transport vehicle.

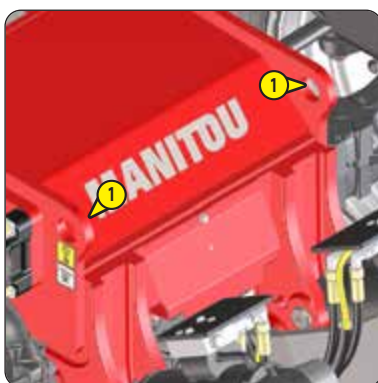
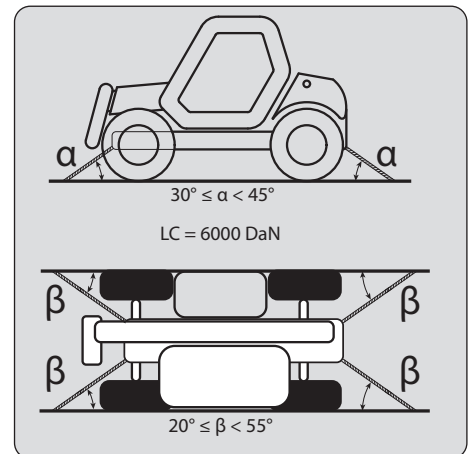
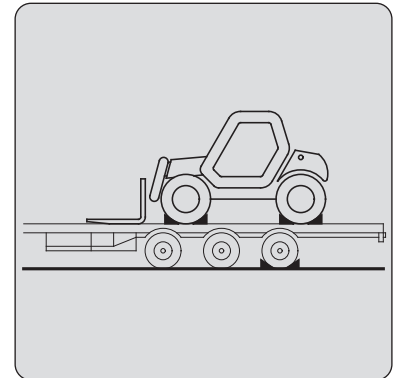

4 - ATTACHMENTS THAT CAN BE ADAPTED TO THE RANGE

ATTACHMENTS THAT CAN BE ADAPTED TO THE RANGE

<i>INTRODUCTION</i>	<i>4-3</i>
<i>PICKING UP THE ATTACHMENTS</i>	<i>4-4</i>
<i>TECHNICAL SPECIFICATIONS OF ATTACHMENTS</i>	<i>4-6</i>
<i>ATTACHMENT GUARDS</i>	<i>4-12</i>

INTRODUCTION

- Your machine must be used with interchangeable equipment. These items are called: ATTACHMENTS.
- A wide range of attachments is available, guaranteed by MANITOU and designed to fit your machine perfectly.

⚠ IMPORTANT ⚠

*Only attachments approved by MANITOU can be used on its machines (↩ TECHNICAL SPECIFICATIONS OF ATTACHMENTS).
The manufacturer cannot be held responsible for any modifications or adaptations to attachments without its knowledge.*

- The attachments are delivered with a load chart concerning your machine. The operator's manual and the load chart should be kept in the places provided in the machine. For standard attachments, their use is governed by the instructions contained on this notice.

⚠ IMPORTANT ⚠

*Maximum loads are defined by the capacity of the machine, taking account of the attachment's weight and center of gravity.
Should the attachment have a lower capacity than the machine, never exceed this limit.*

- Some particular uses require the adaptation of the attachment which is not provided in the price-listed options. Solutions exist, consult your dealer.

⚠ IMPORTANT ⚠

Depending on their size, certain attachments may, when the boom is lowered and retracted, come into contact with the front tires and cause damage to them if excavation is activated in the direction of the discharge.

TO PREVENT THIS RISK, EXTEND THE TELESCOPE TO A SUFFICIENT EXTENT FOR THE PARTICULAR MACHINE AND ATTACHMENT SO THAT THIS CONTACT IS NOT POSSIBLE.

SUSPENDED LOAD

⚠ IMPORTANT ⚠

Suspended loads MUST be handled with the machine designed for that purpose (↩ 1 - OPERATING AND SAFETY INSTRUCTIONS: INSTRUCTIONS FOR HANDLING LOADS: H PICKING UP AND PUTTING DOWN A SUSPENDED LOAD).

USE OF BUCKETS

⚠ IMPORTANT ⚠

MT 1135/1335... machines are essentially intended for handling, for which occasional use with the buckets CBC/CBR/CB4x1 is authorized (only with the boom fully retracted, in order to reduce stresses on the boom head), but under no circumstances for difficult applications (quarry, waste, cereals, agriculture, etc.).

PICKING UP THE ATTACHMENTS

1 - ATTACHMENT WITHOUT HYDRAULICS AND HAND LOCKING DEVICE

FITTING AN ATTACHMENT

- Ensure that the attachment is in a position facilitating the locking to the carriage. If it is not correctly oriented, take the necessary precautions in order to move it safely.
- Check that the locking pin is in position in the bracket (Fig. A).
- Place the machine with the boom lowered in front of and parallel to the attachment, and tilt the carriage forward (Fig. B).
- Bring the carriage under the locking tube of the attachment, slightly raise the boom, tilt the carriage backward in order to position the attachment (Fig. C).
- Lift the attachment off the ground to facilitate locking.

MANUAL LOCKING

- Take the locking pin on the bracket (Fig. A) and lock the attachment (Fig. D). Do not forget to fit the pin.

MANUAL UNLOCKING

- Proceed in the reverse order to MANUAL LOCKING, taking care to refit the locking pin in the bracket (Fig. A).

REMOVING THE ATTACHMENT

- Proceed in the reverse order to FITTING AN ATTACHMENT, taking care to store the attachment flat on the ground and in the closed position.

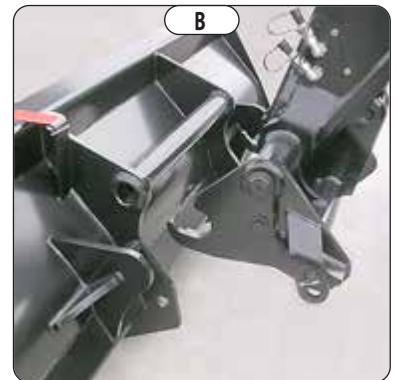
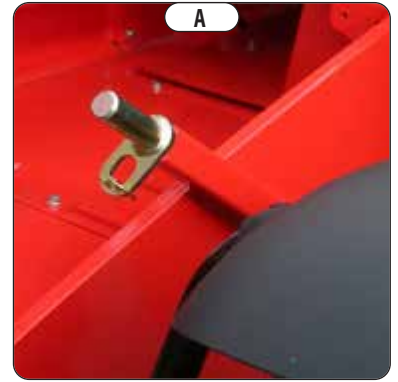

2 - HYDRAULIC ATTACHMENT AND MANUAL LOCKING DEVICE

FITTING AN ATTACHMENT

- Ensure that the attachment is in a position facilitating the locking to the carriage. If it is not correctly oriented, take the necessary precautions in order to move it safely.
- Check that the locking pin is in position in the bracket (Fig. A).
- Place the machine with the boom lowered in front of and parallel to the attachment, and tilt the carriage forward (Fig. B).
- Bring the carriage under the locking tube of the attachment, slightly raise the boom, tilt the carriage backward in order to position the attachment (Fig. C).
- Lift the attachment off the ground to facilitate locking.

MANUAL LOCKING AND CONNECTION OF THE ATTACHMENT

⚠ IMPORTANT ⚠

Make sure that the rapid connectors are clean and protect the holes which are not used, with the caps provided.

- Take the locking pin on the bracket and lock the attachment (fig. D). Do not forget to fit the pin.
- Stop the engine and keep the ignition on the machine.
- Release the pressure in the attachment hydraulic circuit by operating switch 1 on the distributor lever backward and forward 4 or 5 times.
- Connect the quick-release couplers according to the logic of the attachment's hydraulic movements.

MANUAL RELEASE AND DISCONNECTION OF THE ATTACHMENT

- Proceed in the reverse order of paragraph MANUAL LOCKING AND CONNECTION OF THE ATTACHMENT, taking care to refit the locking pin in the bracket.

REMOVING THE ATTACHMENT

- Proceed in the reverse order to FITTING AN ATTACHMENT, taking care to store the attachment flat on the ground and in the closed position.

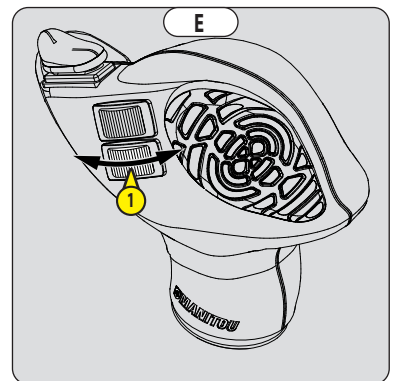
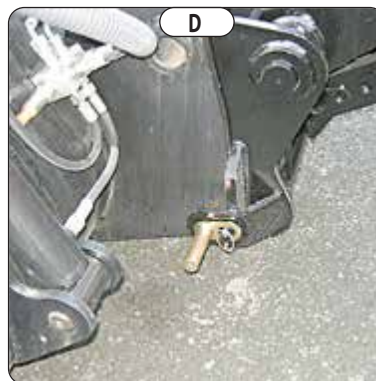
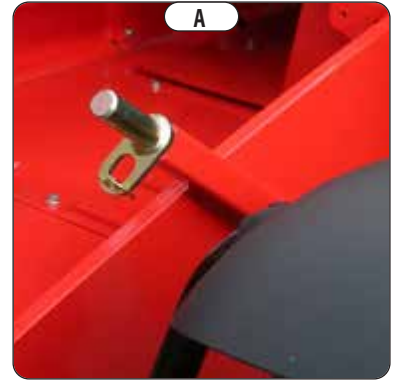

TECHNICAL SPECIFICATIONS OF ATTACHMENTS

FLOATING FORK SIDE-SHIFT CARRIAGE

REFERENCE	TFF 35 MT-1040 DL
Rated capacity	751543 3500 kg
Side-shift	2x100 mm
Width	1040 mm
Weight	345 kg

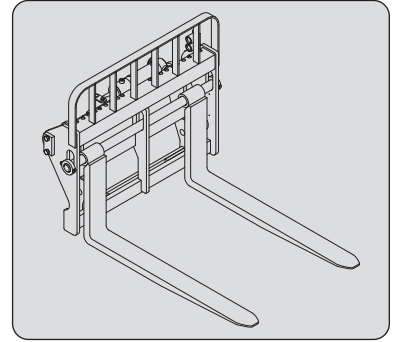

FLOATING FORK

REFERENCE	415801
Cross-section	125x45x1200 mm
Weight	68 kg

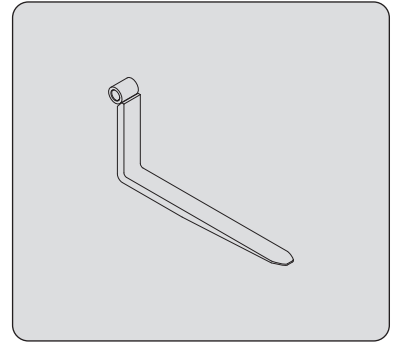

FORK POSITIONER

REFERENCE	CAF 1260/4500 P
Rated capacity	52000273 4500 kg
Spacing	275/1010 mm
Width	1260 mm
Weight	350 kg

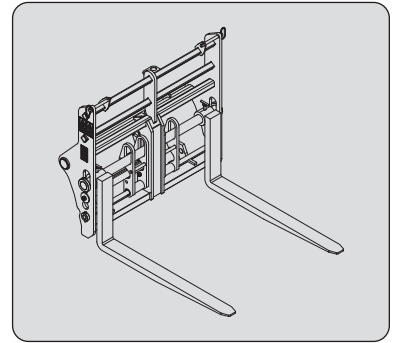

FLOATING FORK

REFERENCE	719611
Cross-section	100x50x1200 mm
Weight	62 kg

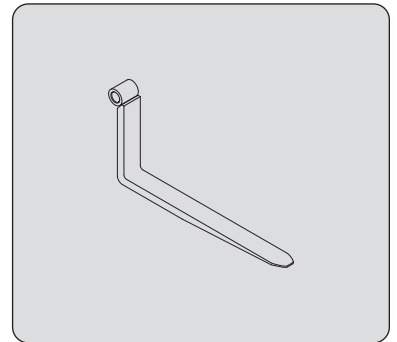

STANDARDIZED TILTING FORK CARRIAGE

REFERENCE	PFB 35 N MT-1260 S2 653744	PFB 35 N MT-1470 S2 653745	PFB 35 N MT-1580 S2 653746
Rated capacity	3500 kg	3500 kg	3500 kg
Width	1260 mm	1470 mm	1580 mm
Weight	95 kg	120 kg	125 kg

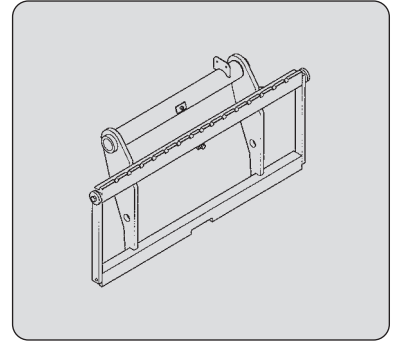

STANDARDIZED FORK

REFERENCE	415618
Cross-section	125x45x1200 mm
Weight	72 kg

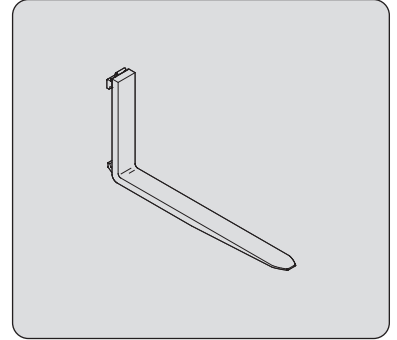

STANDARDIZED TILTING FORK CARRIAGE + STANDARDIZED SIDE-SHIFT CARRIAGE

REFERENCE	PFB 35 N 1260 DL 52000101	PFB 35 N 1580 DL 52000102
Rated capacity	3150 kg	3150 kg
Side-shift	2x100 mm	2x100 mm
Width	1260 mm	1580 mm
Weight	175 kg	300 kg

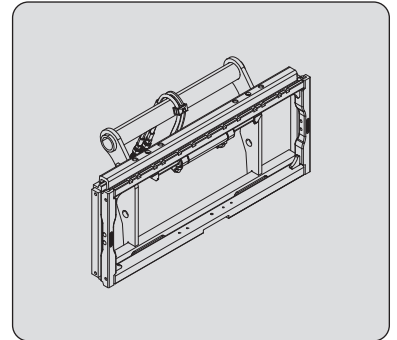

STANDARDIZED TILTING FORK CARRIAGE + LOAD BACK REST

REFERENCE	PFB 35N 1260 LB 52000200	PFB 35N 1470 LB 52000201
Rated capacity	3500 kg	3500 kg
Width	1260 mm	1470 mm
Weight	130 kg	158 kg

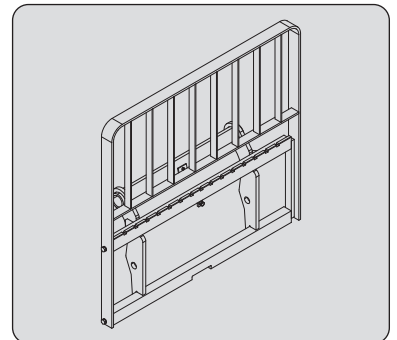

STANDARDIZED TILTING FORK CARRIAGE + STANDARDIZED SIDE-SHIFT CARRIAGE + LOAD BACK REST

REFERENCE	PFB 35 N 1260 DL/LB 52000205
Rated capacity	3150 kg
Side-shift	2x100 mm
Width	1260 mm
Weight	210 kg

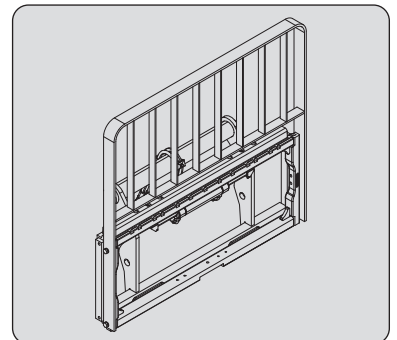

BUILDING BUCKET

REFERENCE	CBC 800 L2250 S3 654471	CBC 900 L2450 S3 654470
Rated capacity	814 ℓ	893 ℓ
Width	2250 mm	2450 mm
Weight	385 kg	410 kg

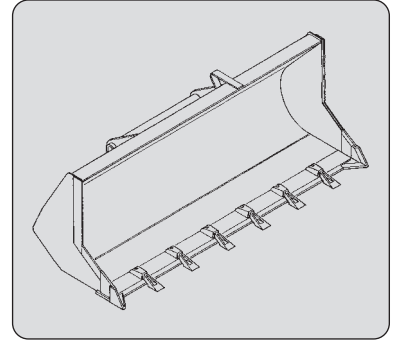

LOADING BUCKET

REFERENCE	CBR 900 L2250 S2 653749	CBR 1000 L2450 S2 654716
Rated capacity	904 ℓ	990 ℓ
Width	2250 mm	2450 mm
Weight	390 kg	410 kg

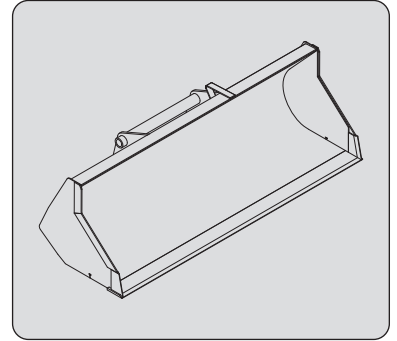

CLAMSHELL BUCKET (REMOVABLE AND REVERSIBLE BLADE)

REFERENCE	CBR 1000 L2450 LDR 52000370
Rated capacity	990 ℓ
Width	2450 mm
Weight	441 kg

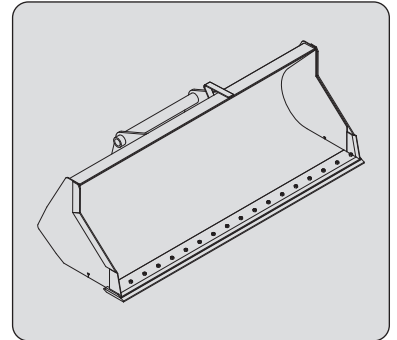

BUCKET 4X1

REFERENCE	CB4X1-850 L2300 751401	CB4X1-900 L2450 751465
Rated capacity	850 ℓ	900 ℓ
Width	2300 mm	2450 mm
Weight	735 kg	765 kg

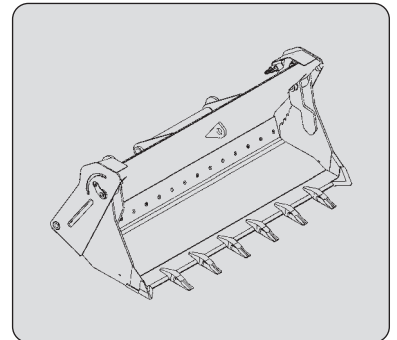

CONCRETE BUCKET (ADAPTABLE ON FORKS)

REFERENCE	BB 500 52000637	BBH 500 52000638
Rated capacity	500 l/1200 kg	500 l/1200 kg
Width	1216 mm	1216 mm
Weight	191 kg	200 kg

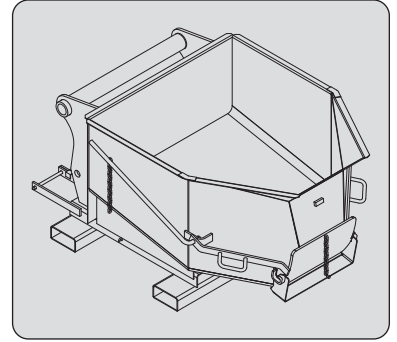

CONCRETE BUCKET WITH SPOUT (ADAPTABLE ON FORKS)

REFERENCE	BBG 500 52000639	BBHG 500 52000640
Rated capacity	500 l/1200 kg	500 l/1200 kg
Width	1216 mm	1216 mm
Weight	200 kg	210 kg

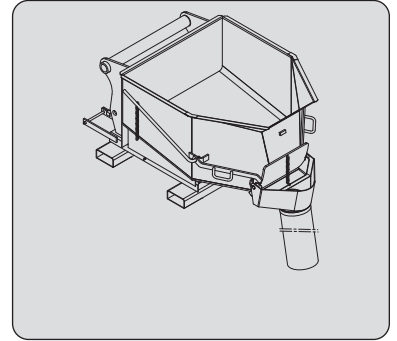

SPOUT BUCKET (ADAPTABLE ON FORKS)

REFERENCE	GL 600 S2 52000528	GL 600 H S2 52000529
Rated capacity	600 l/1440 kg	600 l/1440 kg
Weight	230 kg	245 kg

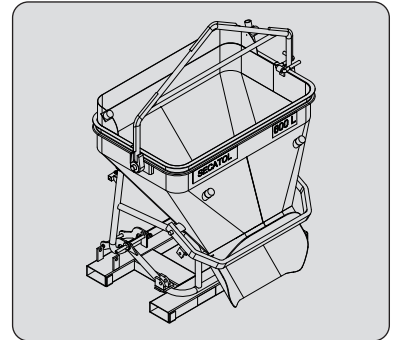

CRANE

	P 600 MT S3
REFERENCE	653228
Rated capacity	600 kg
Weight	170 kg

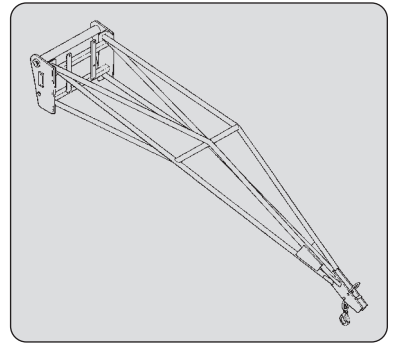

CRANE

	P 4000 MT S2
REFERENCE	653226
Rated capacity	4000 kg/1200 kg
Weight	210 kg

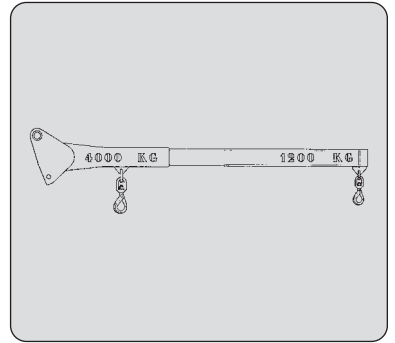

15°/15° MULTI-DIRECTIONAL CRANE JIB

	PO 600 L2500	PO 1000 L1500	PO 2000 L1000
REFERENCE	784641	784642	784643
Rated capacity	600 kg	1000 kg	2000 kg
Weight	320 kg	275 kg	255 kg

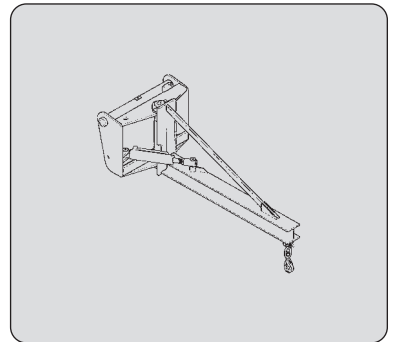

CRANE

	PC 50
REFERENCE	708544
Rated capacity	5000 kg
Weight	120 kg

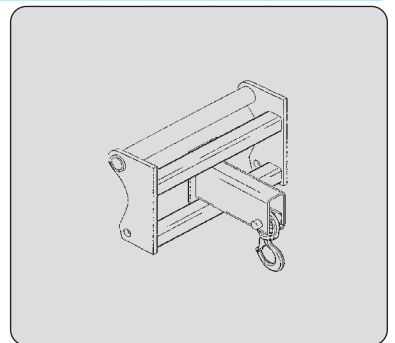

CRANE

REFERENCE	JE 6000/600 939995
Rated capacity	600 kg
Weight	182 kg

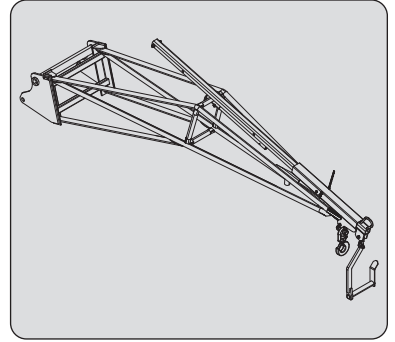

BOOM CRANE WITH BIG BAG

REFERENCE	HBB 1500/2400 931627
Rated capacity	2400 kg
Weight	186 kg

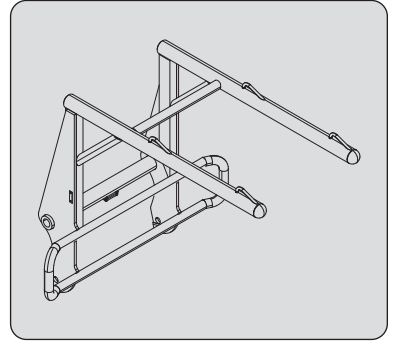

ATTACHMENT GUARDS

FORK GUARD

REFERENCE 227801

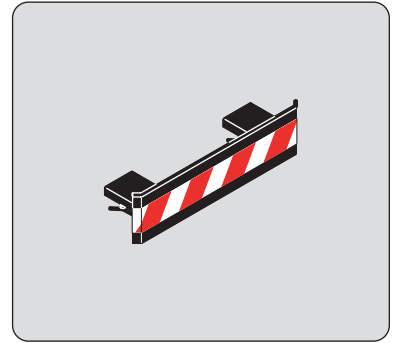

FORK BLOCK FOR FLOATING FORK CARRIAGE

REFERENCE 52722291

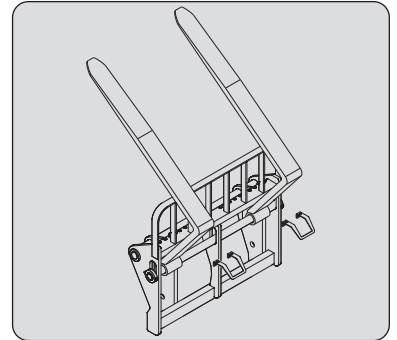

BUCKET PROTECTOR

Always ensure that the width of the protector you choose is less than or equal to the width of the bucket.

Width	REFERENCE 206734	206732	206730
	1375 mm	1500 mm	1650 mm
Width	REFERENCE 235854	206728	206726
	1850 mm	1950 mm	2000 mm
Width	REFERENCE 223771	223773	206724
	2050 mm	2100 mm	2150 mm
Width	REFERENCE 206099	206722	223775
	2250 mm	2450 mm	2500 mm

