



647894EN-USM1(C-03/2023)
(EUROPEAN UNION)

OPERATORS MANUAL
(NOTICE ORIGINALE)

MI 50L D D ST5 S1
MI 60 D D ST5 S1
MI 70 D D ST5 S1
MI 80 D D ST5 S1
MI 100 D D ST5 S1

LEGAL DISCLAIMER

The brochure and all its contents, including diagrams, are the proprietary and confidential intellectual property of Manitou BF and / or its subsidiaries ("Manitou Group"). Any reproduction, publication or dissemination of any part of the brochure without the express written authorization of Manitou Group is strictly prohibited. Any violation of this provision will subject the offending party to prosecution by Manitou Group to the fullest extent of the law. The logos and the company's visual identity are the property of Manitou Group and may not be used without the express written authorization of Manitou Group. All trademarks, registered and unregistered, is and shall remain the property of Manitou BF or its respective owner.

Any reproduction, source code access, decompilation, modification, copy (other than backup copies), correction of errors, transmission or distribution of any software built into Manitou Group machines is strictly prohibited.

In the event that the measures above nevertheless prove essential to enable use of the software, in accordance with its destination, or to obtain the information required for interoperability with other software created independently, the user should contact Manitou Group in advance and Manitou may, at its sole discretion, take the necessary measures or give access to only the information strictly necessary for interoperability.

Any breach of these requirements is likely to constitute a counterfeiting offense subject to legal action by Manitou Group.

Connected Manitou Group machines are equipped with boxes that collect technical data on the machines (such as geo-tracking data or data on component operation). This data, which is organized, processed and enhanced by algorithms and expertise proprietary to Manitou Group, constitutes, in combination with other elements, independent or not, a protected database according to laws & regulations on IP purposes.

It is strictly forbidden to have access to all or part of this database and to use the data (including in the event of accidental access) without explicit prior authorization from Manitou Group. In the event that Manitou Group authorizes a Manitou Group machine user to access all or part of this database, Manitou Group, as producer of this database, cedes to the user only a right to personal, non-exclusive, non transferable use of the database, and only by access to an information technology platform hosted by a server owned or controlled by Manitou Group.

In any case, the following are strictly prohibited:

- any extraction, reproduction, representation, reuse through provision to the public, distribution, transfer, permanent or temporary, on any medium, by any means, and in any form whatsoever, of all or of a qualitatively or quantitatively substantial part of the contents of this database,
- any extraction, reproduction, representation, reuse through provision to the public, distribution, transfer, repeated or systematic of qualitatively or quantitatively insubstantial parts of the content of the database during operations manifestly exceeding normal use of the database by the user of the machine for his own needs,
- any use of means to bypass technical protection measures for databases or software source code embedded in the boxes, in keeping according to laws & regulations on IP purposes.

The latest updated version in force and binding of this document is the version available on demand.

Only the electronic version is maintained.

Contact

MANITOU BF S.A. Public limited company with a board of directors.

Head Office: 430 rue de l'Aubinière - 44150 Ancenis - France

Share capital: 39.668.399,00 euros

Entered in the Nantes Trade and Companies Register under No. 857 802 508.

Tel : +33 (0)2 40 09 10 11

www.manitou-group.com

1. SAFETY	10
1.1. REDUCE RISKS	10
1.2. INSTRUCTIONS TO THE COMPANY MANAGER	11
1.2.1 The Site	11
1.2.2 The Operator	11
1.2.3 The Lift Truck	11
1.2.4 Instructions	12
1.2.5 Maintenance	12
1.3. INSTRUCTIONS FOR THE OPERATOR.....	13
1.3.1 Foreword	13
1.3.2 General Instructions.....	13
1.3.3 Operating Instructions Unladen and Laden	14
1.4. LIFT TRUCK MAINTENANCE INSTRUCTIONS.....	17
1.4.1 General Instructions.....	17
1.4.2 Maintenance	17
1.4.3 Lubricant and Fuel Levels.....	18
1.4.4 Hydraulics	18
1.4.5 Electricity	18
1.4.6 Welding.....	18
1.4.7 Washing The Lift Truck.....	18
1.4.8 Transporting the Lift Truck	18
1.5. IF THE LIFT TRUCK IS NOT TO BE USED FOR A LONG TIME.....	18
1.5.1 Introduction	18
1.5.2 Preparing the Lift Truck	19
1.5.3 Protecting the Engine.....	19
1.5.4 Protecting the Lift Truck.....	19
1.5.5 Bringing the Lift Truck Back into Service	19
1.6. LIFT TRUCK DISPOSAL.....	19
1.6.1 Recycling of Materials	19
1.6.2 Environmental Protection	20
1.7. DECALS	20
1.7.1 Decals location - MI 50L→100 D D ST5 S1	20
2. SPECIFICATIONS & DESCRIPTION	22

2.1. “EC” DECLARATION OF CONFORMITY – MI 50L→100 D D ST5 S1	22
2.2. “UKCA” DECLARATION OF CONFORMITY – MI 50L→100 D D ST5 S1	23
2.3. MACHINE MANUFACTURER PLATE	24
2.4. ATTACHMENT MANUFACTURER PLATE.....	25
2.5. MACHINE SPECIFICATIONS.....	25
2.5.1 Technical datasheet MI 50L D D ST5 S1	25
2.5.2 Technical datasheet MI 60 D D ST5 S1.....	28
2.5.3 Technical datasheet MI 70 D D ST5 S1.....	31
2.5.4 Technical datasheet MI 80 D D ST5 S1.....	34
2.5.5 Technical datasheet MI 100 D D ST5 S1	37
2.5.6 Mast technical datasheet - MI 50L→60 D D ST5 S1.....	40
2.5.7 Mast technical datasheet - MI 70 D D ST5 S1	41
2.5.8 Mast technical datasheet - MI 80 D D ST5 S1	43
2.5.9 Mast technical datasheet - MI 100 D D ST5 S1.....	44
2.5.10 Tires – MI 50L D D ST5 S1	45
2.5.11 Tires – MI 60 D D ST5 S1.....	45
2.5.12 Tires – MI 70 D D ST5 S1	46
2.5.13 Tires – MI 80 D D ST5 S1	46
2.5.14 Tires – MI 100 D D ST5 S1	46
2.5.15 Ground contact pressure - MI 50L→100 D D ST5 S1	46
2.5.16 Load chart.....	48
2.6. MACHINE COMPONENTS	49
2.6.1 Components location – MI 50L→100 D D ST5 S1	49
2.6.2 Driver's cab components location – MI 50L→100 D D ST5 S1	51
2.7. DISPLAY & CONTROLS	52
2.7.1 Machine switches and indicator lights.....	52
2.7.2 Mini-levers controls.....	53
2.7.3 PV380 control panel.....	53
2.7.4 PV380 work page	55
2.7.5 PV380 dashboard setting adjustment menu	57
2.7.6 PV380 faults display menu	57
3. MACHINE OPERATION	59
3.1. INSTALLATION AT THE DRIVER'S CAB	59
3.1.1 Getting on/off the machine.....	59
3.1.2 Adjusting the seat	59
3.1.3 Adjusting the steering wheel	60
3.1.4 Adjusting the armrest	60

3.1.5 Fastening the seat belt	61
3.2. OPERATING THE MACHINE	61
3.2.1 Operating the machine with the operator presence system.....	61
3.2.2 Powering up the machine	61
3.2.3 Powering down the machine	61
3.2.4 Operating the horn	62
3.2.5 Operating the horn on the mini-levers	62
3.2.6 Operating the rotating beacon.....	62
3.2.7 Operating the emergency stop button	62
3.2.8 Operating the heater	62
3.2.9 Operating the air conditioning controls.....	62
3.2.10 Driving the machine	62
3.2.11 Handling a load	64
3.2.12 Management of the pollution control system.....	68
3.3. PARKING AND STORING THE MACHINE.....	69
3.3.1 Parking the machine	69
3.3.2 Storing the machine for a short duration.....	69
3.4. TRANSPORT AND LIFTING OF THE MACHINE	69
3.4.1 Loading/Unloading the machine	69
3.4.2 Tying down the machine	70
4. MAINTENANCE	71
4.1. MAINTENANCE COMPONENTS LOCATION - MI 50L→70 D D ST5 S1.....	71
4.2. MAINTENANCE COMPONENTS LOCATION - MI 80→100 D D ST5 S1	74
4.3. OPENING THE ENGINE COVER.....	76
4.4. OPENING THE REAR COVER - MI 50L→70 D D ST5 S1	77
4.5. OPENING THE REAR COVER - MI 80→100 D D ST5 S1.....	78
4.6. ORIGINAL MANITOU SPARE PARTS AND EQUIPMENT	78
4.6.1 Original manitou spare parts and equipment	78
4.6.2 By allowing the use of non-original manitou parts, you risk	78
4.6.3 By using original Manitou parts, you benefit from.....	78
4.7. MACHINE MAINTENANCE	78
4.7.1 Daily and weekly maintenance.....	78
4.7.2 Mandatory first 500 hours or 6 months of service.....	79
4.7.3 Periodic maintenance.....	79

4.7.4 Occasional maintenance and operation	79
4.8. MAINTENANCE SCHEDULE	79
4.9. SERVICING PROGRAM.....	80
4.9.1 Daily and weekly maintenance.....	80
4.9.2 First mandatory servicing	81
4.9.3 Periodic maintenance.....	81
4.10. 10 HOURS OF SERVICE OR DAILY MAINTENANCE	83
4.10.1 Check lift truck environment.....	83
4.10.2 Check the fuel level.....	83
4.10.3 Check the Diesel Exhaust Fluid "DEF" level	84
4.10.4 Check the engine oil level	84
4.10.5 Check the coolant level.....	85
4.10.6 Check the fuel pre-filter.....	86
4.11. 50 HOURS OF SERVICE OR WEEKLY MAINTENANCE	86
4.11.1 Check the tension of the alternator belt	86
4.11.2 Check the tension of the fan belt.....	86
4.11.3 Check the tension of the air conditioning compressor belt.....	87
4.11.4 Check the gear box seal	87
4.11.5 Check the front axle differential seal	88
4.11.6 Check the tire pressures	88
4.11.7 Check the wheel nut tightening.....	88
4.11.8 Check the hydraulic oil level	88
4.11.9 Check the windscreen washer fluid level	90
4.11.10 Cleaning the dry air filter cartridge.....	90
4.11.11 Clean the radiator core.....	91
4.11.12 Clean the air conditioning condenser core	91
4.11.13 Grease the articulations and guides	92
4.11.14 Adjust the tension & alignment of the mast lifting chains	94
4.12. 500 HOURS OF SERVICE OR 1 YEAR.....	94
4.12.1 Grease the mast lifting chains	94
4.12.2 Replace the engine oil	95
4.13. 1000 HOURS OF SERVICE OR 2 YEARS	96
4.13.1 Check the seat belt	96
4.13.2 Grease the service brake pedal axle.....	96
4.13.3 Replace the fuel filter.....	97
4.13.4 Replace the fuel pre-filter.....	97

4.13.5 Replace the dry air filter cartridge	98
4.13.6 Replace the gearbox oil	98
4.13.7 Replace the hydraulic oil.....	100
4.14. 2000 HOURS OF SERVICE OR 4 YEARS	102
4.14.1 Check the wheel nut tightening torques.....	102
4.14.2 Clean the fuel tank	102
4.14.3 Replace the coolant	103
4.14.4 Replace the dry air filter safety cartridge	104
4.14.5 Replace the front axle differential oil	104
4.15. OCCASIONAL MAINTENANCE	105
4.15.1 Replace wheel.....	105
4.15.2 Replace battery	106
4.16. OCCASIONAL OPERATION	107
4.16.1 Winching/towing the machine.....	107
4.16.2 Lifting the machine - MI 50L→100 D D ST5 S1.....	107
5. REFERENCES & ATTACHMENTS	108
5.1. REFERENCES	108
5.1.1 Lubricants & fuel - MI 50L→100 D D ST5 S1.....	108
5.1.2 Filter elements & belts - MI 50L→100 D D ST5 S1.....	110
5.1.3 Fuses & relays - MI 50L→100 D D ST5 S1.....	110
5.2. ATTACHMENT SPECIFICATIONS	111
5.2.1 Introduction	111
5.2.2 Technical specifications of attachments	112

00. EXPLANATION OF SYMBOLS

DANGER

Indicates an imminent hazardous situation which, if not avoided will result in death or serious injury.

WARNING

Indicates a potentially hazardous situation which, if not avoided, may result in death or serious injury.

CAUTION

Indicates a potentially hazardous situation which, if not avoided, may result in minor injury or damage to property. It is also used to warn users of unsafe practices.

NOTICE

Indicates a practice not related to a physical injury which, if not avoided, may damage the machine.



Indicates a message to draw attention to important information regarding environmental protection.



Indicates special tools for performing a task.



Indicates the value of tightening torque to be applied.



Indicates the weight of an item.

e.g. it helps to anticipate an action linked to a person's health or the choice of lifting equipment.

1. SAFETY

1.1. REDUCE RISKS

04

RED MANITOU

ASSISTANCE | 23 SIMPLE TIPS

The Manitou Group wishes to assist you in reducing the consumption of the machines to help you reduce your carbon footprint.



Chose a machine with an appropriate power rating for your needs.



Switch off your engine after running at idle for more than 3 minutes.



Optimum engine efficiency is achieved at the maximum torque engine speed.



Preferably use a fan control and reversal system.



Favor "smart" electronically-managed transmissions.



Use the air-conditioning with windows and doors closed.



Preferably use LED headlights.



Adapt the type of tire to your environment.



Ensure that your tires are inflated to the correct pressure.



Check the parking brake adjustment.

Preferably use manufacturer-recommended attachments



Check the general condition of your trailer.



Adapt your maximum towable load.



Use the attachments that are suitable for your machine.



Check the hydraulic adjustment of your attachments.



Observe the maintenance periods.



Regularly clean the radiator, the air filter, etc.



Lubricate regularly.



Preferably buy through a manufacturer-approved dealer.



Favor OEM parts.



Study the manufacturers' maintenance contracts.



You can follow eco-driving courses.



Demand to know the consumption and emissions of the machines.



Calculate your consumption and emissions at reduce.manitou.com

Figure 1: Reduce risks program

1.2. INSTRUCTIONS TO THE COMPANY MANAGER

1.2.1 THE SITE

Proper management of the lift truck's area of travel will reduce the risk of accidents, so follow the precautions:

- Make sure that the ground is not unnecessarily uneven or obstructed.
- Make sure that there are no excessive slopes.
- Make sure that the pedestrian traffic is controlled, etc.

1.2.2 THE OPERATOR

Only qualified, authorized personnel can use the lift truck. This authorization is given in writing by the competent manager in the establishment for the use of lift trucks and must be carried permanently by the operator.

⚠ WARNING

Experience has shown that there are a number of inappropriate ways in which the lift truck might be used. Such foreseeable misuse, of which the main examples are listed below, is strictly not permitted

The foreseeable abnormal behavior resulting from ordinary negligence, but which does not result from any wish to put the machinery to any improper use.

The reflex reactions of a person in the event of a malfunction, incident, fault, etc., during operation of the lift truck.

Behavior resulting from application of the "principle of least effort" when performing a task.

For certain machines, the foreseeable behavior of persons such as apprentices, teenagers, handicapped persons, trainees tempted to drive a lift truck, operators tempted to operate a truck for the purposes of a bet, a competition or for their own personal experience.

The person in charge of the equipment must take these criteria into account when assessing the suitability of a person to drive.

1.2.3 THE LIFT TRUCK

THE TRUCK'S SUITABILITY FOR THE JOB

- MANITOU has ensured that this lift truck is suitable for use under the standard operating conditions defined in this operator's manual, with a **STATIC TEST COEFFICIENT OF 1.33** and a **DYNAMIC**

TEST COEFFICIENT OF 1, as specified in harmonised standard **ISO 3691-1** for mast trucks.

- Before commissioning, the company manager must make sure that the lift truck is appropriate for the work to be done, and perform certain tests (in accordance with current legislation).

ADAPTATION OF THE LIFT TRUCK TO STANDARD ENVIRONMENTAL CONDITIONS

- In addition to series equipment mounted on your lift truck, many options are available, such as: road lighting, stop lights, revolving light, reverse lights, reverse buzzer alarm, front light, rear light, etc.
- The operator must take into account the operating conditions to specify the lift truck's signalling and lighting equipment. Contact your dealer.
- Take into account climatic and atmospheric conditions of the site of use.
 - Protection against frost
 - Adaptation of lubricants (ask your dealer for information).
 - Engine filtration .

NOTICE

For operation under average climatic conditions, i.e.: between -15 °C and 35 °C, correct levels of lubricants in all the circuits are checked in production .

For operation under more severe climatic conditions, before starting up, it is necessary to drain all the circuits, then ensure correct levels of lubricants using lubricants properly suited to the relevant ambient temperatures.

The same applies to the cooling liquid.

- Preventing fire risks associated with use in dusty and flammable conditions (e.g. straw, flour, sawdust, organic waste, etc.).
- A lift truck operating in an area without fire extinguishing equipment must be equipped with an individual extinguisher. There are solutions, consult your dealer.

⚠ WARNING

Your lift truck is designed for outdoor use under normal atmospheric conditions and indoor use in suitably aerated and ventilated premises.

It is forbidden to use the lift truck in areas where there is a risk of fire or potential explosion (e.g. Refineries, fuel or gas depots, stores of flammable products, etc.).

Special equipment is available for use in such areas (ask your dealer for information).

- Our trucks comply with Directive 2004/108/EC concerning electromagnetic compatibility (EMC), and with the corresponding harmonised standard EN 12895. Their proper operation is no longer guaranteed if they are used within areas in which the electromagnetic fields exceed the limit specified by that standard (10 V/m).
- Directive 2002/44/EC requires company managers to not expose their employees to excessive vibration doses. There is no recognised code of measurement for comparing the machines of different manufacturers. The actual doses received cannot therefore be measured under actual operating conditions at the user's premises.
- The following are some tips for minimizing these vibration doses:
 - Select the most suitable lift truck and attachment for the intended use.
 - Adapt the seat adjustment to the operator's weight (according to lift truck model) and maintain it in good condition, as well as the cab suspension. Inflate the tyres in accordance with recommendations.
 - Ensure that the operators adapt their operating speed to suit the conditions on site.
 - As far as possible, arrange the site in such a way as to provide a flat running surface and remove obstacles and harmful potholes.

MODIFICATION OF THE LIFT TRUCK

- For your own safety and that of others, you must not change the structure and settings of the various components used in your lift truck by yourself (hydraulic pressure, limiter calibration, engine speed, addition of extra equipment, addition of counterweights, unapproved attachments, alarm systems, etc. In this event, the manufacturer cannot be held liable.

FRENCH ROAD TRAFFIC RULES

- Only one certificate of conformity is issued. It must be kept in a safe place.

- The driving of non-approved lift trucks on the public highway is subject to the provisions of the highway code relating to special machines, defined in article R311-1 of the highway code, in category B of the Equipment Order of 20 November 1969 that determines the procedures applicable to special machines. The lift truck must be fitted with a license plate.

1.2.4 INSTRUCTIONS

- The operator's manual must always be in good condition and kept in the place provided on the lift truck and in the language used by the operator.
- The operator's manual and any plates or stickers which are no longer legible or are damaged must be replaced immediately.
- When handling bulky loads, which restrict your vision, operate the machine in reverse or have a guide.

1.2.5 MAINTENANCE

- Maintenance or repairs other than those detailed in section - MAINTENANCE must be carried out by qualified personnel (consult your dealer) and in the necessary safety conditions to preserve the health of the operator and any third party.

NOTICE

Your lift truck must be inspected periodically to make sure that it remains in compliance.

The frequency of this inspection is defined by current legislation in the country in which the lift truck is used.

- Example for France: "The manager in charge of the establishment using a lift truck must open and maintain a maintenance log for each machine (order of 2 March 2004) and undergo a general periodic inspection every 6 months (order of 1 March 2004)".

1.3. INSTRUCTIONS FOR THE OPERATOR

1.3.1 FOREWORD

⚠ WARNING

The risk of accident while using, servicing or repairing your lift truck can be restricted if you follow the safety instructions and safety measures detailed in these instructions.

Failure to respect the safety and operating instructions, or the instructions for repairing or servicing your lift truck may lead to serious, even fatal accident.

- Only the operations and maneuvers described in this operator's manual must be performed. The manufacturer cannot predict all possible risky situations. Consequently, the safety instructions given in the operator's manual and on the lift truck itself are not exhaustive.
- At any time, as an operator, you must envisage, within reason, the possible risk to yourself, to others or to the lift truck itself when you use it.

⚠ WARNING

In order to reduce or prevent any danger with a MANITOU-approved attachment, follow the instructions in the section - ADAPTABLE ATTACHMENTS AS OPTIONS ON THE RANGE: INTRODUCTION.

1.3.2 GENERAL INSTRUCTIONS

OPERATOR'S MANUAL

- Read the operator's manual carefully.
- The operator's manual must always be in good condition and kept in the place provided on the lift truck.
- You must report any plates and stickers which are no longer legible, or which are damaged.

AUTHORISATION FOR USE IN FRANCE

(or see current legislation in other countries)

- Only qualified, authorized personnel can use the lift truck. This authorization is given in writing by the appropriate person in the establishment with respect to the use of lift trucks and must be carried permanently by the operator.
- The operator is not competent to authorize the driving of the lift truck by another person.

MAINTENANCE

- The operator must immediately advise his superior if his lift truck is not in good working order or does not obey the safety notice.
- The operator is prohibited from carrying out any repairs or adjustments himself, unless he has been trained for this purpose. He must keep the lift truck properly cleaned if this is among his responsibilities.
- The operator is responsible for carrying out daily maintenance
- The operator is responsible for deciding and adjusting the frequency of cleaning necessary to prevent the risk of fire ensuing from the build-up of flammable material(s). The operator must pay special attention to all the areas of the lift truck where these risk materials are likely to accumulate.

TYRES

⚠ DANGER

Do not use the lift truck if the tyres are incorrectly inflated, damaged or excessively worn, because this could put your own safety or that of others at risk, or cause damage to the lift truck itself.

The fitting of foam inflated tyres is prohibited and is not guaranteed by the manufacturer, excepting prior authorization.

- The operator must ensure tyres are adapted to the nature of the ground. There are optional solutions, consult your dealer.
 - SAND tyres.
 - Farm Tyres.
 - Snow chains.
- The lift truck's four tyres must be of the same brand and of the same usage category (normal, snow or special), have the same structure (radial or diagonal) and have the same degree of tread wear.
- In the event of tyre replacement, use tyres authorized by MANITOU that are of the same type and dimensions. Using different tyres voids the lift truck's type approval and you may be liable.
- If you are replacing just one of the lift truck's tyres (e.g. because it is damaged), we recommend choosing a tyre with the same degree of wear as the remaining tyres so as not to damage the transmission's kinematic chain.

MODIFICATION OF THE LIFT TRUCK

For your safety and that of others, you must not change the structure and settings of the various components used in your lift truck (hydraulic pressure, calibrating limiters, engine speed, addition of extra equipment,

addition of counterweight, unapproved attachments, alarm systems, etc.) yourself. In this event, the manufacturer cannot be held responsible.

Lifting People

It is forbidden to lift or carry people.

1.3.3 OPERATING INSTRUCTIONS UNLADEN AND LADEN

BEFORE STARTING THE LIFT TRUCK

- Perform the daily maintenance operations.
- Make sure that the driver's cab is clean, particularly the floor and floor mat. Do a check that no movable object may prevent the operation of the lift truck.
- Make sure that the forward-reverse lever is in neutral.
- Make sure that the lights, indicators and windscreen wipers are working properly.
- Make sure that the rear view mirrors are in good condition, clean and properly adjusted.
- Make sure that the horn works.

DRIVER'S OPERATING INSTRUCTIONS AVAILABLE IN THE DRIVER'S CAB

⚠ DANGER

Under no circumstances must the seat be adjusted while the lift truck is moving.

- Whatever his experience, the operator is advised to familiarize himself with the position and operation of all the controls and instruments before operating the lift truck.
- Wear clothes suited for driving the lift truck and avoid loose clothes.
- Make sure that you have the appropriate protective equipment for the task to be performed.
- Prolonged exposure to high noise levels may cause hearing problems. It is recommended to wear ear muffs to protect against excessive noise.
- Always face the lift truck when getting into and out of the driver's cab.
 - Use the handle(s) provided for this purpose.
 - Use the step(s).
 - Do not jump out of the lift truck.
- Always pay attention when using the lift truck. Do not listen to radio or music using headphones or earphones.

- Never operate the lift truck when hands or feet are wet or soiled with greasy substances.
- For increased comfort, adjust the seat to your requirements and adopt the correct position in the driver's cab.
- The operator must always be in his normal position in the driver's cab. It is prohibited to have arms or legs, or generally any part of the body, protruding from the driver's cab of the lift truck.
- The safety belt must be worn and adjusted to the operator's size.
- The control units must never in any event be used for any other than their intended purposes (e.g. climbing onto or down from the lift truck, portmanteau, etc.).
- If the control components are fitted with a forced operation (lever lock) device, it is not permitted to leave the cab without first putting these controls in neutral.
- Do not carry passengers either on the lift truck or in the driver's cab.

ENVIRONMENT

- Comply the site safety regulations.
- Examine the work area.
- If you have to use the lift truck in a dark area or at night, make sure that it is equipped with working lights.
- During handling operations, make sure that no one is in the way of the lift truck and its load.
- Do not allow anybody to come near the working area of the lift truck or pass beneath an elevated load.
- When using the lift truck on a transverse slope, before lifting the boom obey the instructions given in the section - INSTRUCTIONS FOR HANDLING A LOAD: D - TRANSVERSE ATTITUDE OF THE LIFT TRUCK
- Travelling on a longitudinal slope, do the steps that follow::
 - Drive and brake gently.
 - Moving without load: forks or attachment must face downhill.
 - Moving with load: Forks or attachment must face uphill.
- Take into account the lift truck's dimensions and its load before trying to negotiate a narrow or low passageway.
- Never move onto a loading platform without having first checked:
 - That it is suitably positioned and made fast.

- That the unit to which it is connected (wagon, lorry, etc.) will not shift.
- That this platform is prescribed for the total weight of the lift truck to be loaded.
- That this platform is prescribed for the size of the lift truck.
- Be careful in the area of loading bays, trenches, scaffolding, soft ground and manholes.
- Make sure that the ground is stable and firm under the wheels and/or stabilizers before lifting or removing the load. If necessary, add sufficient wedging under the stabilizers.
- Make sure that the scaffolding, loading platform, pilings or ground is capable of bearing the load.
- Never stack loads on uneven ground, they may tip over.
- When working near aerial lines, make sure there is sufficient safety distance between the working area of the lift truck and the aerial line.

DANGER

You must consult your local electrical agency. You could be electrocuted or seriously injured if you operate or park the lift truck too close to power cables.

In the event of high winds, do not carry out handling work that jeopardises the stability of the lift truck and its load, particularly if the load catches the wind badly.

- Prevent fire risks associated with the use in dusty and flammable conditions (e.g. straw, flour, sawdust, organic waste, etc.).

Visibility

- The safety of people within the lift truck's working area, as well as that of the lift truck itself and the operator are dependent on good operator visibility of the lift truck's immediate vicinity in all situations and at all times.
- This lift truck has been designed to allow good operator visibility (direct or indirect by means of rear-view mirrors) of the immediate vicinity of the lift truck during running operations, unladen and boom in the transport position.
- Special precautions must be taken if the size of the load restricts visibility toward the front. These include:
 - moving in reverse.
 - site layout,
 - assisted by a person directing the maneuver (while standing outside the truck's area of travel), making sure to keep this person clearly in view always,
 - in any case, do not reverse over long distances.
- If visibility of your road is inadequate, ask someone to assist by directing the maneuver (while standing outside the truck's area of travel), making sure to keep this person clearly in view always.
- Keep all components affecting visibility in a clean, properly adjusted state and in good working order (e.g. windscreens, windows, windscreen wipers, windscreen washers, driving and work lights, rear-view mirrors)..

Starting the lift truck

SAFETY INSTRUCTIONS

WARNING

Risk of losing control.

Risk of losing lateral and frontal stability of the lift truck. The operator must remain in control of the lift truck.

In the event of the lift truck overturning, do not try to leave the cabin during the incident. YOUR BEST PROTECTION IS TO STAY FASTENED IN THE CABIN.

- Observe the company's traffic regulations or, by default, the public highway code.
- Do not carry out operations which exceed the capacities of your lift truck or attachments.
- Always drive the lift truck with the forks or attachment to the transport position, i.e. at 300mm from the ground and the carriage sloping backwards.
- Only carry loads which are balanced and properly anchored to avoid any risk of a load falling off.
- Ensure that pallets, cases, etc. are in good order and suitable for the load to be lifted.
- Familiarise yourself with the lift truck on the terrain where it will be used.
- Ensure that the service brakes are working properly.
- The loaded lift truck must not travel at speeds in excess of 12 km/h.
- Drive smoothly at an appropriate speed for the operating conditions (land configuration, load on the lift truck).
- Do not use the hydraulic mast controls when the lift truck is moving.
- Do not manoeuvre the lift truck with the mast in the raised position unless under exceptional circumstances and then with extreme caution, at

very low speed and using gentle braking. Ensure that visibility is adequate.

- Take bends slowly.
- In all circumstances make sure you are in control of your speed.
- On damp, slippery or uneven terrain, drive slowly.
- Brake gently, never abruptly.
- Only use the lift truck's forward/reverse selector from a stationary position and never do so abruptly.
- Do not drive with your foot on the brake pedal.
- Always remember that hydrostatic type steering is extremely sensitive to movement of the steering wheel, so turn it gently and not jerkily.
- Never leave the engine running when the lift truck is unattended.
- Do not leave the cab when the lift truck has a raised load.
- Look where you are going and always make sure you have good visibility along the route.
- Use the rear-view mirrors frequently.
- Drive round obstacles.
- Never drive on the edge of a ditch or steep slope.
- It is dangerous to use two lift trucks simultaneously to handle heavy or voluminous loads, since this operation requires particular precautions to be taken. It must only be used exceptionally and after risk analysis.
- The ignition switch has an emergency stop mechanism in case of an operating anomaly occurring in the case of lift trucks not fitted with a punch-operated cut-out.

INSTRUCTIONS

- Always drive the lift truck with the forks or attachment to the transport position, i.e. at 300mm from the ground and the carriage sloping backwards.
- For lift trucks with gearboxes, use the selected gear.
- Release the hand brake.
- Shift the forward/reverse selector to the selected direction of travel and accelerate gradually until the lift truck moves off.

Stopping the lift truck

SAFETY INSTRUCTIONS

- Never leave the ignition key in the lift truck during the operator's absence.
- When the lift truck is stationary, or if the operator has to leave his cab (even for a moment), place the forks or attachment on the ground, apply the

parking brake and place the forward/reverse selector in neutral.

- Make sure that the lift truck is not stopped in any position that will interfere with the traffic flow and at less than one metre from the track of a railway.
- In the event of prolonged parking on a site, protect the lift truck from bad weather, particularly from frost (check the level of antifreeze), close and lock all the lift truck accesses (doors, windows, cowl, etc.).

INSTRUCTIONS

- Park the lift truck on flat ground or on an incline lower than 15%.
- Set the forward/reverse selector to neutral.
- Apply the parking brake.
- For lift trucks with gearboxes, place the gear lever in neutral.
- Lower the forks or attachment to rest on the ground.
- When using an attachment with a grab or jaws, or a bucket with hydraulic opening, close the attachment fully.
- Before stopping the lift truck after a long working period, leave the engine idling for a few moments, to allow the coolant liquid and oil to lower the temperature of the engine and transmission. Do not forget this precaution, in the event of frequent stops or warm stalling of the engine, or else the temperature of certain parts will rise significantly due to the stopping of the cooling system, with the risk of badly damaging such parts.
- Stop the engine with the ignition switch.
- Remove the ignition key.
- Lock all the accesses to the lift truck (doors, windows, cowl)
- For lift trucks operating on gas carburisation, shut the LPG bottle. For a long-lasting stop, let the engine stop naturally by shutting the LPG bottle before switching off the ignition, so as to eliminate all the fuel in the feed tube.

DRIVING THE LIFT TRUCK ON THE PUBLIC HIGHWAY (FRENCH ROAD TRAFFIC RULES)

⚠ DANGER

Never move in neutral (forward/reverse selector or gear lever in neutral or transmission cut-off button pressed) to preserve the lift truck engine brake.

Failure to follow this instruction on a slope will lead to excessive speed which may make the lift truck uncontrollable (steering, brakes) and may cause serious mechanical damage.

The driving of non-approved lift trucks on the public highway is subject to the provisions of the highway code relating to special machines, defined in article R311-1 of the highway code, in category B of the Equipment Order of 20 November 1969 that determines the procedures applicable to special machines. The lift truck must be fitted with a license plate.

SAFETY INSTRUCTIONS

- Operators driving on the public highway must comply with current highway code legislation.
- The lift truck must comply with current road legislation. If necessary, there are optional solutions. Contact your dealer.

INSTRUCTIONS

- Make sure the revolving light is in place, switch it on and verify its operation.
- Make sure the lights, indicators and windscreen wipers are working properly.
- Switch off the working headlights if the lift truck is fitted with them.
- Place the attachment 300 mm from the ground.

DRIVING THE LIFT TRUCK WITH A FRONT-MOUNTED ATTACHMENT

- You must comply with current regulations in your country, covering the possibility of driving on the public highway with a front-mounted attachment on your lift truck.
- If road legislation in your country authorises circulation with a front-mounted attachment, you must at least:
 - Protect and report any sharp and/or dangerous edges on the attachment.
 - The attachment must not be loaded.
 - Make sure that the attachment does not mask the lighting range of the forward lights.
 - Make sure that current legislation in your country does not require other obligations.

OPERATING THE LIFT TRUCK WITH A TRAILER (For lift trucks equipped with a towing system)

- For using a trailer, observe the regulations in force in your country (maximum travel speed, braking, maximum weight of trailer, etc.).
- Do not forget to connect the trailer's electrical equipment to that of the lift truck.
- The trailer's braking system must comply with current legislation.
- If pulling a trailer with assisted braking, the tractor lift truck must be equipped with a trailer braking mechanism. In this case, do not forget to connect the trailer braking equipment to the lift truck.

- The vertical force on the towing hook must not exceed the maximum authorised by the manufacturer (consult the manufacturer's plate on your lift truck).
- The authorised gross vehicle weight must not exceed the maximum weight authorised by the manufacturer (consult the manufacturer's plate on your lift truck).



IF NECESSARY, CONSULT YOUR DEALER.

1.4. LIFT TRUCK MAINTENANCE INSTRUCTIONS

1.4.1 GENERAL INSTRUCTIONS

- Ensure that the area is sufficiently ventilated before starting the lift truck.
- Wear clothes suitable for the maintenance of the lift truck. Do not wear jewelry and loose clothes. Tie back and protect your hair, if necessary.
- Before carrying out any work on the lift truck:
 - Switch off the engine.
 - Apply the parking brake
 - Remove the ignition key.
- Read the operator's manual carefully.
- Carry out all repairs immediately, even if the repairs concerned are minor.
- Repair all leaks immediately, even if the leak concerned is minor.
- Ensure that process materials and of spare parts are disposed in all safely and in an ecological manner.
- Be careful of the risk of burns and splashing (exhaust, radiator, engine, etc.).

1.4.2 MAINTENANCE

Perform the periodic service to keep your lift truck in good working condition. Failure to perform the periodic service may cancel the contractual guarantee.

MAINTENANCE LOGBOOK

The maintenance operations carried out in accordance with the recommendations given in section - MAINTENANCE and the other inspection, servicing or repair operations or modifications performed on the lift truck or its attachments are recorded in a maintenance logbook. The entry for each operation must include the date of the work, the names of the individuals or companies having performed them, the type of operation and its frequency, if applicable. The part

numbers of any lift truck components that are replaced are indicated.

1.4.3 LUBRICANT AND FUEL LEVELS

- Use the recommended lubricants (never use contaminated lubricants).
- Do not fill the fuel tank when the engine is running.
- Only fill up the fuel tank in areas specified for this purpose.
- Do not fill the fuel tank to the maximum level.
- Do not smoke or approach the lift truck with a flame when the fuel tank is open or is being filled.

1.4.4 HYDRAULICS

- Any work on the load handling hydraulic circuit is not permitted except for the operations described in 4 - MAINTENANCE.
- Do not attempt to loosen connections, hoses or a hydraulic component with the circuit under pressure.

⚠ DANGER

It is dangerous to change the setting and remove the balancing valves or safety valves which may be fitted to your lift truck cylinders.

The HYDRAULIC ACCUMULATORS that may be fitted on your lift truck are pressurized units. Removing these accumulators and their pipework is a dangerous operation and must only be performed by approved personnel (consult your dealer).

These operations must only be performed by approved personnel (consult your dealer).

1.4.5 ELECTRICITY

- Do not short-circuit the starter relay to start the engine. If the forward/reverse selector is not in neutral and the parking brake is not applied, the lift truck may suddenly start to move.
- Do not put metal items on the battery.
- Disconnect the battery before working on the electrical circuit.

1.4.6 WELDING

- Disconnect the battery before carrying out any welding operations on the lift truck.
- When carrying out electric welding work on the lift truck, connect the negative cable from the

equipment directly to the part being welded to avoid high tension current passing through the alternator.

- Never carry out welding or any work which gives off heat on an assembled tyre. The heat will increase the pressure which can cause the tyre to explode.
- If the lift truck is equipped with an electronic control unit, disconnect this before starting to weld to avoid the risk of causing irreparable damage to electronic components.

1.4.7 WASHING THE LIFT TRUCK

- Clean the lift truck or at least the area concerned before any intervention.
- Remember to close and lock all accesses to the lift truck (doors, windows, cowl, etc.).
- During washing, avoid the articulations and electrical components and connections.
- If necessary, protect against penetration of water, steam or cleaning agents, components susceptible of being damaged, particularly electrical components and connections and the injection pump.
- Clean the lift truck of any fuel, oil or grease trace.

1.4.8 TRANSPORTING THE LIFT TRUCK

⚠ WARNING

Transporting the lift truck involves real risks for the operator and others involved.

Towing, winching, slinging or transporting the lift truck, see Maintenance, Occasional operation.

1.5. IF THE LIFT TRUCK IS NOT TO BE USED FOR A LONG TIME

1.5.1 INTRODUCTION

The following recommendations are intended to prevent the lift truck from being damaged when it is withdrawn from service for an extended period.

NOTICE

Procedures to follow if the lift truck is not to be used for a long time, and for starting it up again afterward must be performed by your dealership. This period of long-term stoppage must not exceed 12 months.

1.5.2 PREPARING THE LIFT TRUCK

- Clean the lift truck thoroughly.
- Check and repair any fuel, oil, water or air leaks.
- Replace or repair any worn or damaged parts.
- Wash the painted surfaces of the lift truck in clear and cold water and wipe them.
- Touch up the paint work if necessary.
- Stop the lift truck.
- Make sure the mast cylinder rods are all in the retracted position.
- Release the pressure in the hydraulic circuits.

1.5.3 PROTECTING THE ENGINE

- Contact your dealer to obtain the procedure for protecting the inside of the engine (use of protection product).
- Fill the tank with fuel .
- Drain and replace the coolant .
- Leave the engine running at idling speed for a few minutes, then switch off.
- Replace the engine oil and oil filter .
- Run the engine for a short time so that the oil and cooling liquid circulate inside.
- Disconnect the battery and store it in a safe place away from the cold after charging it to a maximum
- Block the outlet with waterproof adhesive tape.
- Remove the drive belts and store them in a safe place
- Disconnect the engine cut-off solenoid on the injection pump and carefully insulate the connection.

1.5.4 PROTECTING THE LIFT TRUCK

- Set the lift truck on axle stands so that the tyres are off the ground.
- Release the parking brake (depending on the model of lift truck).
- Protect cylinder rods which will not be retracted, from corrosion.
- Wrap the tyres.



If the lift truck is to be stored outdoors, cover it with a waterproof tarpaulin.

1.5.5 BRINGING THE LIFT TRUCK BACK INTO SERVICE

⚠ WARNING

Ensure the area is sufficiently ventilated before starting the lift truck.

- Remove the waterproof adhesive tape from all the holes.
- Refit and reconnect the battery.
- Remove the protection from the cylinder rods.
- Perform the daily maintenance operations .
- Put the handbrake on and remove the axle stands.
- Drain and clean the fuel tank .
- Fill the fuel tank with clean diesel filtered through the filler port.
- Replace the fuel filter .
- Replace the fuel pre-filter (depending on the model of lift truck)
- Drain and rinse the DEF tank (depending on the model of lift truck)
- Top up, slowly fill the tank with new "DEF" (Diesel Exhaust Fluid) up to the bottom of the filler neck (depending on the model of lift truck)
- Refit the drive belts and adjust the tension .
- Turn the engine over with the starter, to allow the oil pressure to rise.
- Reconnect the engine cut-off solenoid.
- Lubricate the lift truck completely .
- Start up the lift truck, following the safety instructions and regulations.
- Carry out all the boom hydraulic movements, concentrating on the ends of travel for each cylinder.

1.6. LIFT TRUCK DISPOSAL

1.6.1 RECYCLING OF MATERIALS

Metals

- Metals are 100 % recoverable and recyclable.

Plastics

- Plastic parts are identified with a marking in accordance with current regulations.

- A limited range of materials are used to simplify the recycling process.
- Most of the plastic components are made up of "thermoplastic" that are easily recycled by melting, granulating or grinding.

Rubber

- Tyres and seals can be ground for use in cement manufacture or to obtain reusable granules.

Glass

- Glass items can be removed and collected for processing by glaziers.

1.6.2 ENVIRONMENTAL PROTECTION

By entrusting the maintenance of your lift truck to the MANITOU network, the risk of pollution is limited and the contribution to environmental protection contribution is made.

Worn or Damaged Parts

- Do not dump them in the countryside.

- MANITOU and its network have signed-up to a scheme of environmental protection through recycling.

Used Oil

- The MANITOU network organizes the collection and processing of used oil.
- By handing over your waste oil to MANITOU, the risk of pollution is limited.

Used Batteries

- Do not throw away batteries, as they contain metals that are harmful for the environment.
- Return them to the MANITOU network or any other approved collection point.



MANITOU seeks to manufacture lift trucks providing the best performance and limiting polluting emissions.

1.7. DECALS

1.7.1 DECALS LOCATION - MI 50L → 100 D D ST5 S1

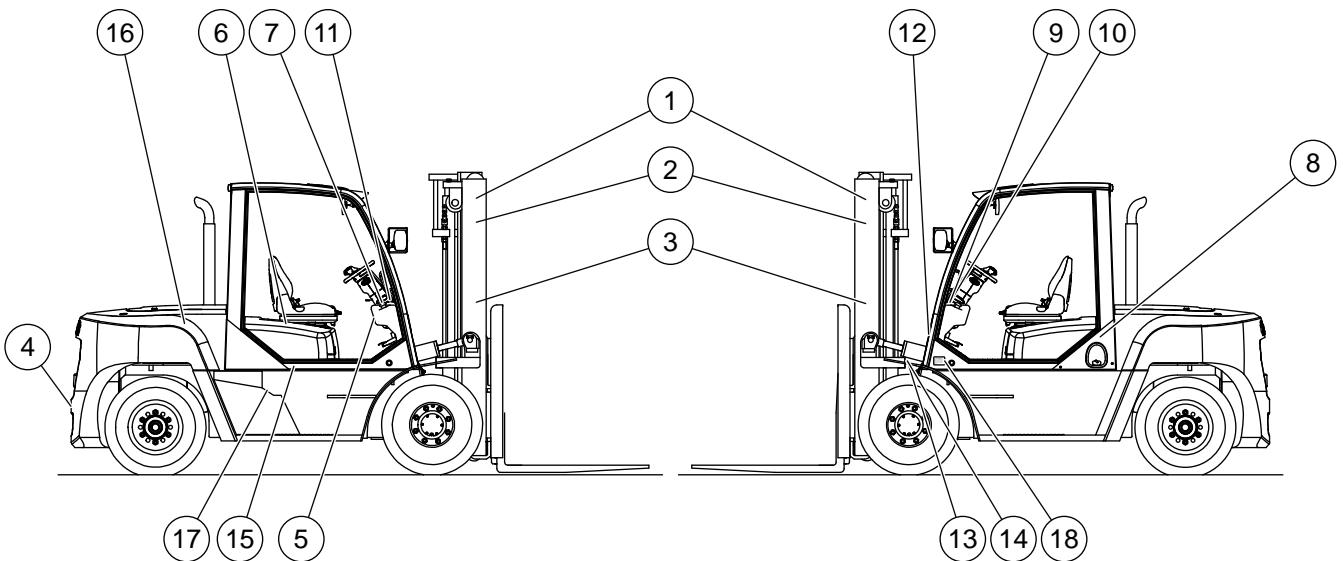

Figure 2: Decals location

Table 1. List of decals

Marker	Reference	Description	Option
1	24653	Slinging point	
2	52521805	Slinging warning	
3	52719360	Safety instructions for mast trucks	
4	289101	Tie-down point	
5	52549319	DPF inside	

Marker	Reference	Description	Option
6	52722738	Parked DPF regeneration (standard location, without option)	
7	52722738	Parked DPF regeneration (location in case of option)	•
8	52521857	Diesel ULSD	
9	300681	Safety instructions	
10	52523299	Emergency stop	
11	52521862	Machine start-up instruction	
12	239596	Acoustic plate 106 dB	
13	52521861	Warning, do not climb the mast	
14	828054	Crushing hazard	
15	52521860	Hydraulic oil tank	
16	Consult your dealer	Warning, risk of cutting	
17	Consult your dealer	DEF min. 5L (only for MI 80 →100 D D ST5 S1)	
18	52759172	Warning risk of misuse (for UK only)	

2. SPECIFICATIONS & DESCRIPTION

2.1. “EC” DECLARATION OF CONFORMITY – MI 50L → 100 D D ST5 S1

This document is a specimen of the “EC” declaration of conformity mirroring the content of the original declaration provided with the machine.

This specimen and the original document may contain data fields which does not apply to the machine. These fields are left blank if not relevant.

See the original certificates for all relevant values for your machine.

1) **DÉCLARATION «CE» DE CONFORMITÉ (originale)**
«EC» DECLARATION OF CONFORMITY (original)

2) Constructeur, *Manufacturer* : MANITOU BF
 3) Adresse, *Address* : 430, RUE DE L'AUBINIÈRE - B.P 10249
 44158 - ANCENIS - CEDEX - FRANCE

4) Titulaire du dossier technique, *Holder of the technical file* : MANITOU BF
 3) Adresse, *Address* : 430, RUE DE L'AUBINIÈRE - B.P 10249
 44158 - ANCENIS - CEDEX - FRANCE

5) Le constructeur déclare que la machine décrite ci-après, *The manufacturer declares that the machine described below* :

MI 50L D D ST5 S1
 MI 60 D D ST5 S1
 MI 70 D D ST5 S1
 MI 80 D D ST5 S1
 MI 100 D D ST5 S1

6) Est conforme aux directives suivantes et à leurs transpositions en droit national (si applicables),
Complies with the following directives and their transpositions into national law (if applicable) :

2006/42/CE

7) Pour les machines annexe IV, *For annex IV machines* :

8) Numéro d'attestation, *Certificate number* :

9) Organisme notifié, *Notified body* :

2000/14/CE + 2005/88/CE

10) Procédure appliquée, *Applied procedure* :

9) Organisme notifié, *Notified body* :

11) Niveau de puissance acoustique, *Sound power level* :

12) Mesuré, *Measured* : dB (A)
 13) Garanti, *Guaranteed* : dB (A)

2014/30/UE

14) Normes harmonisées utilisées, *Harmonised standards used* :

15) Normes ou dispositions techniques utilisées, *Standards or technical provisions used* :

16) Fait à, *Done at* : 17) Date, *Date* :

18) Nom du signataire, *Name of signatory* :

19) Fonction, *Function* :

20) Société, *Company* :

21) Signature, *Signature* :

Figure 3: “EC” declaration of conformity – MI 50L → 100 D D ST5 S1 (specimen) page 1/2



Figure 4: "EC" declaration of conformity – MI 50L→100 D D ST5 S1 (specimen) page 2/2

2.2. "UKCA" DECLARATION OF CONFORMITY – MI 50L→100 D D ST5 S1

This document is a specimen of the "UKCA" declaration of conformity mirroring the content of the original declaration provided with the machine.

This specimen and the original document may contain data fields which does not apply to the machine. These fields are left blank if not relevant.

See the original certificates for all relevant values for your machine.

UKCA DECLARATION OF CONFORMITY

Manufacturer: **MANITOU BF**
 Address: **430, RUE DE L'AUBINIÈRE - BP 10249
 44158 ANCENIS CEDEX - FRANCE**

Authorized representative: **MANITOU UK**
Ebblake Industrial Estate - Dorset BH 31 6BB
Verwood - United Kingdom

The manufacturer declares that the below described machinery:

MI 50L D D ST5 S1
MI 60 D D ST5 S1
MI 70 D D ST5 S1
MI 80 D D ST5 S1
MI 100 D D ST5 S1

Complies with the following legislation:
The supply of Machinery (Safety) Regulations 2008, as amended

The machine is designed for the lifting of persons:
 Applied procedure: **Non applicable**
 Certificate number: **Non applicable**
 Dated:
 Approved body: **Non applicable**

**Noise Emission in the Environment by Equipment
 for use Outdoors Regulations 2001, as amended**

Applied procedure:
 Approved body:

Sound power level:
 Measured: dB (A)
 Guaranteed: dB (A)

Electromagnetic Compatibility Regulations 2016, as amended

The following designated standards have been addressed:
EN 12895

The following standards or technical guidance have been addressed:
 -

At: Date:
 Name of signatory:
 Position:
 Company:
 Signature:

Figure 5: "UKCA" declaration of conformity – MI 50L→100 D D ST5 S1 (specimen)

2.3. MACHINE MANUFACTURER PLATE

"Designation" Designation	
"Series" Series	
"Power" Power	
"Year of manufacture" Year of manufacture	
"Model year" Model year	
"Max vertical force (on trailer hook)" Max vertical force (on trailer hook)	
"Serial number / Product identification number" Serial number / Product identification number	
"Authorized gross vehicle weight" Authorized gross vehicle weight	
"Unladen mass" Unladen weight	

"Rated capacity" Rated capacity	
"Drag strain" Pulling force	

2.4. ATTACHMENT MANUFACTURER PLATE

"Modele" Model	
"N° série" Serial number	
"Année fabrication" Year of manufacture	
"Masse à vide" Unladen weight	
"Centre de gravité" Centre of gravity	
"Capacité Nominale" Rated capacity	
"Pression service" Working pressure	

2.5. MACHINE SPECIFICATIONS

2.5.1 TECHNICAL DATASHEET MI 50L D D ST5 S1



The specifications given are not binding on the manufacturer and can be modified without prior notification.

Specifications

Table 2. Specifications

	Designation	Unit	Value
1.1	Manufacturer		MANITOU
1.2	Type of model		MI 50L D D ST5 S1
1.3	Drive : battery, diesel, gasoline, LPG, mains		Diesel
1.4	Driving position : manual, walking alongside, standing, seated		Seated
1.5	Nominal load / Load on forks (basic capacity)	Q (t)	5
1.6	Load center of gravity	c (mm)	600
1.7	Distance from the load-bearing surface to centre of front axle	x (mm)	598
1.8	Wheelbase	y (mm)	2300

Weights

Table 3. Weights

	Designation	Unit	Value
2.1	Weight of truck in working order	kg	8810
2.2	Front axle load on loaded truck	kg	12250
2.2.1	Rear axle load on loaded truck	kg	1560
2.3	Front axle load on unloaded truck	kg	4330
2.3.1	Rear axle load on unloaded truck	kg	4480

Tires

Table 4. Tires

	Designation	Unit	Value
3.1	Tire equipment : bandage (V), superelastic (SE), pneumatic (L)		SE
3.2	Size of front wheels	" / mm	8.25-15 14PR
3.3	Size of rear wheels	" / mm	8.25-15 14PR
3.4	Number of front wheels (x = drive wheels)		4x
3.4.1	Number of rear wheels (x = drive wheels)		2
3.5	Front wheel gauge (middle of wheels)	b10 (mm)	1489
3.6	Rear wheel gauge (middle of wheels)	b11 (mm)	1700

Dimensions

Table 5. Dimensions

	Designation	Unit	Value
4.1	Tilt of mast forward	$\alpha(^{\circ})$	6
4.1.1	Tilt of mast backward	$\beta(^{\circ})$	12
4.2	Height mast lowered	h1 (mm)	2500
4.3	Normal free lift	h2 (mm)	160
4.4	Height of lift	h3 (mm)	3000
4.5	Height mast extended	h4 (mm)	4407
4.6	Height of standard overhead guard or cab or cab with air conditioning	h6 (mm)	2430
4.7	Seat height	h7 (mm)	1350
4.8	Height of towing bar	h10 (mm)	710
4.9	Overall length	l1 (mm)	4719
4.10.	Length to face of forks	l2 (mm)	3499
4.11	Total width (overall) – Single tires / Dual tires	b1 (mm)	1990
4.12	Thickness of fork arms	s (mm)	60
4.12.1	Width of fork arms	e (mm)	150
4.12.2	Fork arms length	l (mm)	1220
4.13	Fork carriage to DIN 15173 A/B		FEM4A
4.14	Fork carriage width	b3 (mm)	1700
4.15	Ground clearance of mast	m1 (mm)	190
4.16	Ground clearance at centre of wheelbase	m2 (mm)	270
4.17	Width of aisle for pallet 1000x1200 crossways	Ast (mm)	5030
4.18	Width of aisle for pallet 800x1200 lengthways	Ast (mm)	5230
4.19	Turning radius (position down/up)	Wa (mm)	3230
4.20.	Inner turning radius	b13 (mm)	110

Performances

Table 6. Performances

	Designation	Unit	Value
5.1	Travelling speed laden	km/h	6/12/23
5.1.1	Travelling speed unladen 2WD / 4WD	km/h	6/12/24
5.2	Lifting speed laden	m/s	0.38
5.2.1	Lifting speed unladen	m/s	0.46
5.3	Lowering speed laden	m/s	0.48
5.3.1	Lowering speed unladen	m/s	0.42
5.4	Nominal towing power laden	N	64000
5.4.1	Nominal towing power unladen	N	25400
5.5	Gradeability laden	%	>20
5.5.1	Gradeability unladen	%	>20
5.6	Acceleration time laden	s	-
5.7	Service brake		Hydraulic

Motors

Table 7. Motors

	Designation	Unit	Value
6.1	Engine manufacture / type		Deutz TCD 3.6 L4 (EU Stage V)
6.2	Engine power acc. To ISO 1585	KW	55.4
6.3	Rated speed	tr/min	2300
6.4	No. Of cylinders / displacement	cm3	4/3621
6.5	Fuel consumption acc. To VDI cycle	L/h	6.5

Miscellaneous

Table 8. Miscellaneous

	Designation	Unit	Value
7.1	Hydraulic pressure for attachments	Bar	190
7.2	Oil volume for attachments	L/min	55
7.3	Sound level at driver's ear according to DIN 12053 (overhead guard / cab)	dB (A)	84
7.4	Towing coupling design / DIN type	-	-
7.5	Average weighted acceleration on driver's body (according to standard NF EN 13059)	m/s ²	1.2

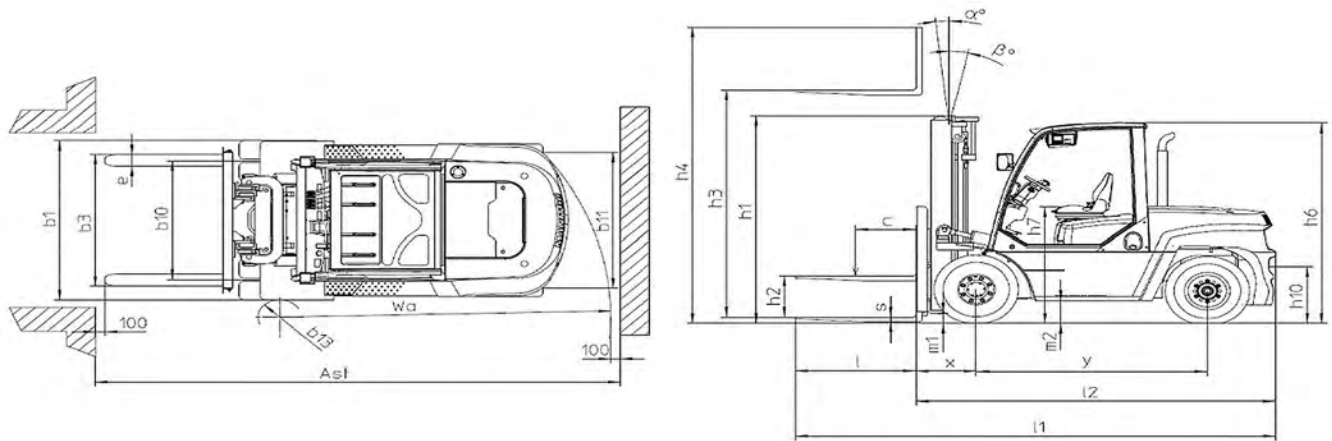

Figure 6: Dimensions diagram

2.5.2 TECHNICAL DATASHEET MI 60 D D ST5 S1



The specifications given are not binding on the manufacturer and can be modified without prior notification.

Specifications

Table 9. Specifications

	Designation	Unit	Value
1.1	Manufacturer		MANITOU
1.2	Type of model		MI 60 D D ST5 S1
1.3	Drive : battery, diesel, gasoline, LPG, mains		Diesel
1.4	Driving position : manual, walking alongside, standing, seated		Seated
1.5	Nominal load / Load on forks (basic capacity)	Q (t)	6
1.6	Load center of gravity	c (mm)	600
1.7	Distance from the load-bearing surface to centre of front axle	x (mm)	598
1.8	Wheelbase	y (mm)	2300

Weights

Table 10. Weights

	Designation	Unit	Value
2.1	Weight of truck in working order	kg	9210
2.2	Front axle load on loaded truck	kg	13340
2.2.1	Rear axle load on loaded truck	kg	1870
2.3	Front axle load on unloaded truck	kg	4130
2.3.1	Rear axle load on unloaded truck	kg	5080

Tires

Table 11. Tires

	Designation	Unit	Value
3.1	Tyre equipment : bandage (V), superelastic (SE), pneumatic (L)		SE
3.2	Size of front wheels	" / mm	8.25-15 14PR
3.3	Size of rear wheels	" / mm	8.25-15 14PR
3.4	Number of front wheels (x = drive wheels)		4x
3.4.1	Number of rear wheels (x = drive wheels)		2
3.5	Front wheel gauge (middle of wheels)	b10 (mm)	1489
3.6	Rear wheel gauge (middle of wheels)	b11 (mm)	1700

Dimensions

Table 12. Dimensions

	Designation	Unit	Value
4.1	Tilt of mast forward	α (°)	6
4.1.1	Tilt of mast backward	β (°)	12
4.2	Height mast lowered	h1 (mm)	2500
4.3	Normal free lift	h2 (mm)	160
4.4	Height of lift	h3 (mm)	3000
4.5	Height mast extended	h4 (mm)	4407
4.6	Height of standard overhead guard or cab or cab with air conditioning	h6 (mm)	2430
4.7	Seat height	h7 (mm)	1350
4.8	Height of towing bar	h10 (mm)	710
4.9	Overall length	l1 (mm)	4729
4.10.	Length to face of forks	l2 (mm)	3529
4.11	Total width (overall) – Single tires / Dual tires	b1 (mm)	1990
4.12	Thickness of fork arms	s (mm)	60
4.12.1	Width of fork arms	e (mm)	150
4.12.2	Fork arms length	l (mm)	1220
4.13	Fork carriage to DIN 15173 A/B		FEM4A
4.14	Fork carriage width	b3 (mm)	1700
4.15	Ground clearance of mast	m1 (mm)	190
4.16	Ground clearance at centre of wheelbase	m2 (mm)	270
4.17	Width of aisle for pallet 1000x1200 crossways	Ast (mm)	5080
4.18	Width of aisle for pallet 800x1200 lengthways	Ast (mm)	5280
4.19	Turning radius (position down/up)	Wa (mm)	3260
4.20.	Inner turning radius	b13 (mm)	110

Performances

Table 13. Performances

	Designation	Unit	Value
5.1	Travelling speed laden	km/h	6 / 12 / 23
5.1.1	Travelling speed unladen 2WD / 4WD	km/h	6 / 12 / 24
5.2	Lifting speed laden	m/s	0.36
5.2.1	Lifting speed unladen	m/s	0.46
5.3	Lowering speed laden	m/s	0.48
5.3.1	Lowering speed unladen	m/s	0.42
5.4	Nominal towing power laden	N	64300
5.4.1	Nominal towing power unladen	N	26700
5.5	Gradeability laden	%	>20
5.5.1	Gradeability unladen	%	>20
5.6	Acceleration time laden	s	-
5.7	Service brake		Hydraulic

Motors

Table 14. Motors

	Designation	Unit	Value
6.1	Engine manufacture / type		Deutz TCD 3.6 L4 (EU Stage V)
6.2	Engine power acc. To ISO 1585	KW	55.4
6.3	Rated speed	tr/min	2300
6.4	No. Of cylinders / displacement	cm ³	4/3621
6.5	Fuel consumption acc. To VDI cycle	L/h	6.5

Miscellaneous

Table 15. Miscellaneous

	Designation	Unit	Value
7.1	Hydraulic pressure for attachments	Bar	190
7.2	Oil volume for attachments	L/min	55
7.3	Sound level at driver's ear according to DIN 12053 (overhead guard / cab)	dB (A)	84
7.4	Towing coupling design / DIN type	-	-
7.5	Average weighted acceleration on driver's body (according to standard NF EN 13059)	m/s ²	1.2

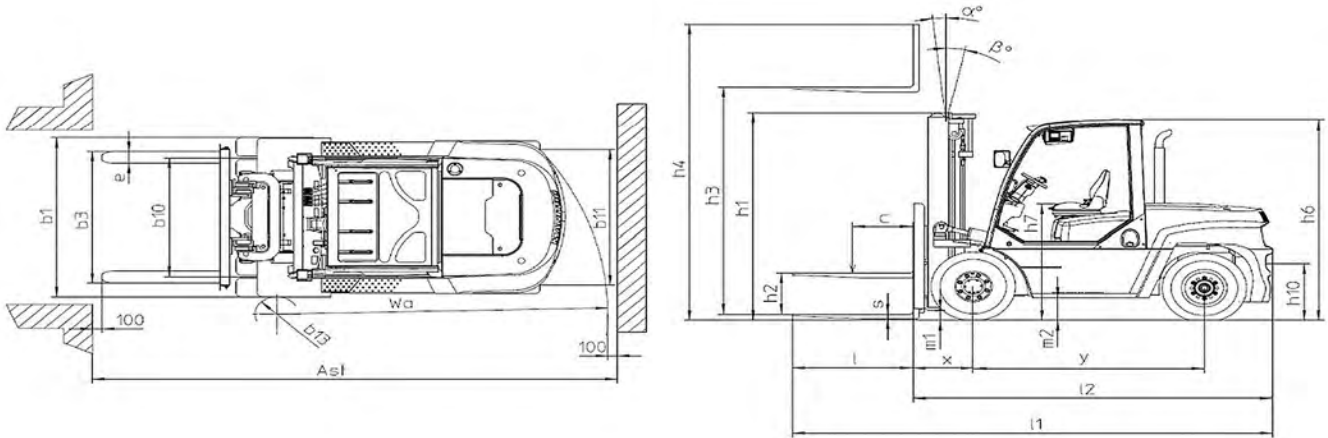

Figure 7: Dimensions diagram

2.5.3 TECHNICAL DATASHEET MI 70 D D ST5 S1



The specifications given are not binding on the manufacturer and can be modified without prior notification.

Specifications

Table 16. Specifications

	Designation	Unit	Value
1.1	Manufacturer		MANITOU
1.2	Type of model		MI 70 D D ST5 S1
1.3	Drive : battery, diesel, gasoline, LPG, mains		Diesel
1.4	Driving position : manual, walking alongside, standing, seated		Seated
1.5	Nominal load / Load on forks (basic capacity)	Q (t)	7
1.6	Load center of gravity	c (mm)	600
1.7	Distance from the load-bearing surface to centre of front axle	x (mm)	603
1.8	Wheelbase	y (mm)	2300

Weights

Table 17. Weights

	Designation	Unit	Value
2.1	Weight of truck in working order	kg	10110
2.2	Front axle load on loaded truck	kg	15290
2.2.1	Rear axle load on loaded truck	kg	1820
2.3	Front axle load on unloaded truck	kg	4120
2.3.1	Rear axle load on unloaded truck	kg	5990

Tires

Table 18. Tires

	Designation	Unit	Value
3.1	Tire equipment : bandage (V), superelastic (SE), pneumatic (L)		SE
3.2	Size of front wheels	" / mm	8.25-15 14PR
3.3	Size of rear wheels	" / mm	8.25-15 14PR
3.4	Number of front wheels (x = drive wheels)		4x
3.4.1	Number of rear wheels (x = drive wheels)		2
3.5	Front wheel gauge (middle of wheels)	b10 (mm)	1489
3.6	Rear wheel gauge (middle of wheels)	b11 (mm)	1700

Dimensions

Table 19. Dimensions

	Designation	Unit	Value
4.1	Tilt of mast forward	$\alpha(^{\circ})$	6
4.1.1	Tilt of mast backward	$\beta(^{\circ})$	12
4.2	Height mast lowered	h1 (mm)	2500
4.3	Normal free lift	h2 (mm)	160
4.4	Height of lift	h3 (mm)	3000
4.5	Height mast extended	h4 (mm)	4407
4.6	Height of standard overhead guard or cab or cab with air conditioning	h6 (mm)	2430
4.7	Seat height	h7 (mm)	1350
4.8	Height of towing bar	h10 (mm)	710
4.9	Overall length	l1 (mm)	4804
4.10.	Length to face of forks	l2 (mm)	3604
4.11	Total width (overall) – Single tires / Dual tires	b1 (mm)	1990
4.12	Thickness of fork arms	s (mm)	65
4.12.1	Width of fork arms	e (mm)	150
4.12.2	Fork arms length	l (mm)	1220
4.13	Fork carriage to DIN 15173 A/B		FEM4A
4.14	Fork carriage width	b3 (mm)	1700
4.15	Ground clearance of mast	m1 (mm)	190
4.16	Ground clearance at centre of wheelbase	m2 (mm)	270
4.17	Width of aisle for pallet 1000x1200 crossways	Ast (mm)	5150
4.18	Width of aisle for pallet 800x1200 lengthways	Ast (mm)	5350
4.19	Turning radius (position down/up)	Wa (mm)	3330
4.20.	Inner turning radius	b13 (mm)	110

Performances

Table 20. Performances

	Designation	Unit	Value
5.1	Travelling speed laden	km/h	6 / 12 / 23
5.1.1	Travelling speed unladen 2WD / 4WD	km/h	6 / 12 / 24
5.2	Lifting speed laden	m/s	0.36
5.2.1	Lifting speed unladen	m/s	0.41
5.3	Lowering speed laden	m/s	0.48
5.3.1	Lowering speed unladen	m/s	0.42
5.4	Nominal towing power laden	N	65000
5.4.1	Nominal towing power unladen	N	27500
5.5	Gradeability laden	%	>20
5.5.1	Gradeability unladen	%	>20
5.6	Acceleration time laden	s	-
5.7	Service brake		Hydraulic

Motors

Table 21. Motors

	Designation	Unit	Value
6.1	Engine manufacture / type		Deutz TCD 3.6 L4 (EU Stage V)
6.2	Engine power acc. To ISO 1585	KW	55.4
6.3	Rated speed	tr/min	2300
6.4	No. Of cylinders / displacement	cm ³	4/3621
6.5	Fuel consumption acc. To VDI cycle	L/h	6.5

Miscellaneous

Table 22. Miscellaneous

	Designation	Unit	Value
7.1	Hydraulic pressure for attachments	Bar	190
7.2	Oil volume for attachments	L/min	55
7.3	Sound level at driver's ear according to DIN 12053 (overhead guard / cab)	dB (A)	84
7.4	Towing coupling design / DIN type	-	-
7.5	Average weighted acceleration on driver's body (according to standard NF EN 13059)	m/s ²	1.2

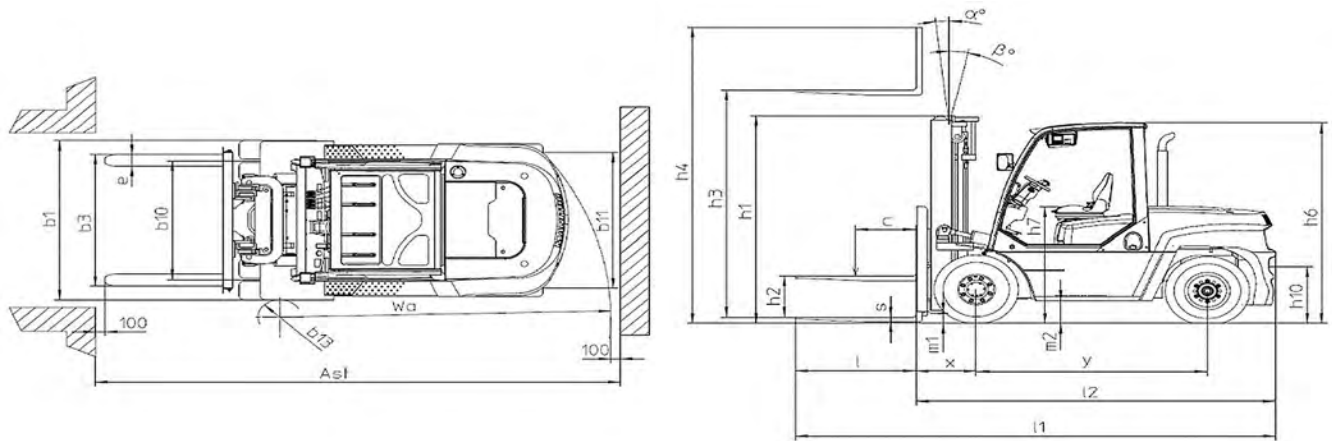

Figure 8: Dimensions diagram

2.5.4 TECHNICAL DATASHEET MI 80 D D ST5 S1



The specifications given are not binding on the manufacturer and can be modified without prior notification.

Specifications

Table 23. Specifications

	Designation	Unit	Value
1.1	Manufacturer		MANITOU
1.2	Type of model		MI 80 D D ST5 S1
1.3	Drive : battery, diesel, gasoline, LPG, mains		Diesel
1.4	Driving position : manual, walking alongside, standing, seated		Seated
1.5	Nominal load / Load on forks (basic capacity)	Q (t)	8
1.6	Load center of gravity	c (mm)	600
1.7	Distance from the load-bearing surface to centre of front axle	x (mm)	714
1.8	Wheelbase	y (mm)	2600

Weights

Table 24. Weights

	Designation	Unit	Value
2.1	Weight of truck in working order	kg	12580
2.2	Front axle load on loaded truck	kg	18370
2.2.1	Rear axle load on loaded truck	kg	2210
2.3	Front axle load on unloaded truck	kg	5210
2.3.1	Rear axle load on unloaded truck	kg	7370

Tires

Table 25. Tires

	Designation	Unit	Value
3.1	Tire equipment : bandage (V), superelastic (SE), pneumatic (L)		SE
3.2	Size of front wheels	" / mm	9-20 14PR
3.3	Size of rear wheels	" / mm	9-20 14PR
3.4	Number of front wheels (x = drive wheels)		4x
3.4.1	Number of rear wheels (x = drive wheels)		2
3.5	Front wheel gauge (middle of wheels)	b10 (mm)	1628
3.6	Rear wheel gauge (middle of wheels)	b11 (mm)	1700

Dimensions

Table 26. Dimensions

	Designation	Unit	Value
4.1	Tilt of mast forward	$\alpha(^{\circ})$	6
4.1.1	Tilt of mast backward	$\beta(^{\circ})$	12
4.2	Height mast lowered	h1 (mm)	2700
4.3	Normal free lift	h2 (mm)	200
4.4	Height of lift	h3 (mm)	3000
4.5	Height mast extended	h4 (mm)	4210
4.6	Height of standard overhead guard or cab or cab with air conditioning	h6 (mm)	2580
4.7	Seat height	h7 (mm)	1350
4.8	Height of towing bar	h10 (mm)	505
4.9	Overall length	l1 (mm)	5504
4.10.	Length to face of forks	l2 (mm)	4004
4.11	Total width (overall) – Single tires / Dual tires	b1 (mm)	2165
4.12	Thickness of fork arms	s (mm)	75
4.12.1	Width of fork arms	e (mm)	160
4.12.2	Fork arms length	l (mm)	1500
4.13	Fork carriage to DIN 15173 A/B		FEM4A
4.14	Fork carriage width	b3 (mm)	2000
4.15	Ground clearance of mast	m1 (mm)	250
4.16	Ground clearance at centre of wheelbase	m2 (mm)	339
4.17	Width of aisle for pallet 1000x1200 crossways	Ast (mm)	5644
4.18	Width of aisle for pallet 800x1200 lengthways	Ast (mm)	5844
4.19	Turning radius (position down/up)	Wa (mm)	3730
4.20.	Inner turning radius	b13 (mm)	1350

Performances

Table 27. Performances

	Designation	Unit	Value
5.1	Travelling speed laden	km/h	6/12/27
5.1.1	Travelling speed unladen 2WD / 4WD	km/h	6/12/26
5.2	Lifting speed laden	m/s	0.38
5.2.1	Lifting speed unladen	m/s	0.4
5.3	Lowering speed laden	m/s	0.43
5.3.1	Lowering speed unladen	m/s	0.39
5.4	Nominal towing power laden	N	65000
5.4.1	Nominal towing power unladen	N	45000
5.5	Gradeability laden	%	>20
5.5.1	Gradeability unladen	%	>20
5.6	Acceleration time laden	s	-
5.7	Service brake		Hydraulic

Motors

Table 28. Motors

	Designation	Unit	Value
6.1	Engine manufacture / type		Deutz TCD 3.6 L4 □EU Stage V□
6.2	Engine power acc. To ISO 1585	KW	85
6.3	Rated speed	tr/min	2200
6.4	No. Of cylinders / displacement	cm ³	4 / 3621
6.5	Fuel consumption acc. To VDI cycle	L/h	9.6

Miscellaneous

Table 29. Miscellaneous

	Designation	Unit	Value
7.1	Hydraulic pressure for attachments	Bar	195
7.2	Oil volume for attachments	L/min	155
7.3	Sound level at driver's ear according to DIN 12053 (overhead guard / cab)	dB (A)	84
7.4	Towing coupling design / DIN type	-	-
7.5	Average weighted acceleration on driver's body (according to standard NF EN 13059)	m/s ²	1.2

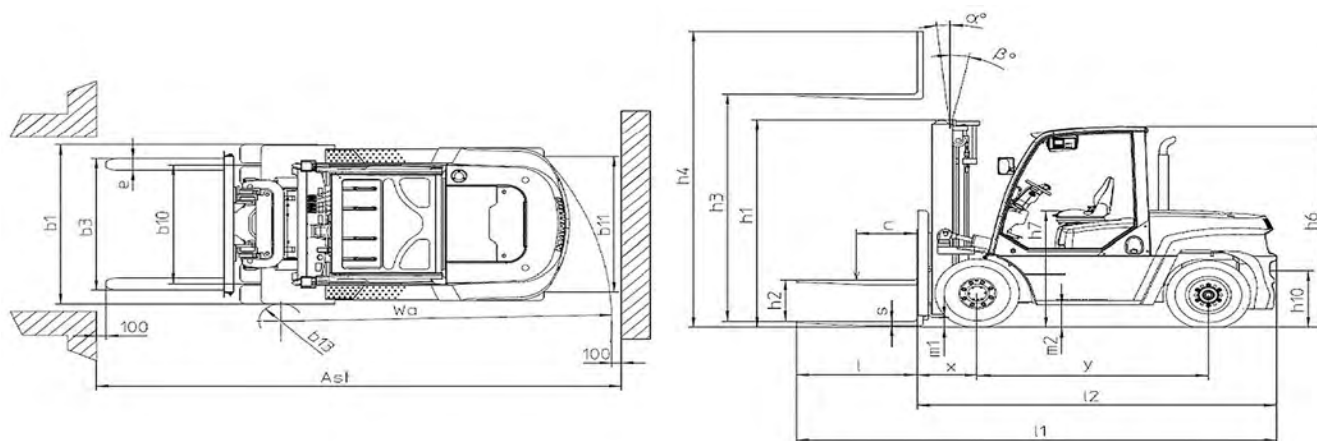

Figure 9: Dimensions diagram

2.5.5 TECHNICAL DATASHEET MI 100 D D ST5 S1



The specifications given are not binding on the manufacturer and can be modified without prior notification.

Specifications

Table 30. Specifications

	Designation	Unit	Value
1.1	Manufacturer		MANITOU
1.2	Type of model		MI 100 D D ST5 S1
1.3	Drive : battery, diesel, gasoline, LPG, mains		Diesel
1.4	Driving position : manual, walking alongside, standing, seated		Seated
1.5	Nominal load / Load on forks (basic capacity)	Q (t)	10
1.6	Load center of gravity	c (mm)	600
1.7	Distance from the load-bearing surface to centre of front axle	x (mm)	726
1.8	Wheelbase	y (mm)	2800

Weights

Table 31. Weights

	Designation	Unit	Value
2.1	Weight of truck in working order	kg	14380
2.2	Front axle load on loaded truck	kg	21900
2.2.1	Rear axle load on loaded truck	kg	2470
2.3	Front axle load on unloaded truck	kg	6820
2.3.1	Rear axle load on unloaded truck	kg	7560

Tires

Table 32. Tires

	Designation	Unit	Value
3.1	Tire equipment : bandage (V), superelastic (SE), pneumatic (L)		SE
3.2	Size of front wheels	" / mm	9-20 14PR
3.3	Size of rear wheels	" / mm	9-20 14PR
3.4	Number of front wheels (x = drive wheels)		4x
3.4.1	Number of rear wheels (x = drive wheels)		2
3.5	Front wheel gauge (middle of wheels)	b10 (mm)	1628
3.6	Rear wheel gauge (middle of wheels)	b11 (mm)	1700

Dimensions

Table 33. Dimensions

	Designation	Unit	Value
4.1	Tilt of mast forward	$\alpha(^{\circ})$	6
4.1.1	Tilt of mast backward	$\beta(^{\circ})$	12
4.2	Height mast lowered	h1 (mm)	2850
4.3	Normal free lift	h2 (mm)	200
4.4	Height of lift	h3 (mm)	3000
4.5	Height mast extended	h4 (mm)	4555
4.6	Height of standard overhead guard or cab or cab with air conditioning	h6 (mm)	2580
4.7	Seat height	h7 (mm)	1350
4.8	Height of towing bar	h10 (mm)	505
4.9	Overall length	l1 (mm)	5736
4.10.	Length to face of forks	l2 (mm)	4236
4.11	Total width (overall) – Single tires / Dual tires	b1 (mm)	2165
4.12	Thickness of fork arms	s (mm)	80
4.12.1	Width of fork arms	e (mm)	160
4.12.2	Fork arms length	l (mm)	1500
4.13	Fork carriage to DIN 15173 A/B		FEM4A
4.14	Fork carriage width	b3 (mm)	2000
4.15	Ground clearance of mast	m1 (mm)	250
4.16	Ground clearance at centre of wheelbase	m2 (mm)	339
4.17	Width of aisle for pallet 1000x1200 crossways	Ast (mm)	5866
4.18	Width of aisle for pallet 800x1200 lengthways	Ast (mm)	6066
4.19	Turning radius (position down/up)	Wa (mm)	3940
4.20.	Inner turning radius	b13 (mm)	1396

Performances

Table 34. Performances

	Designation	Unit	Value
5.1	Travelling speed laden	km/h	6/12/27
5.1.1	Travelling speed unladen 2WD / 4WD	km/h	6/12/26

	Designation	Unit	Value
5.2	Lifting speed laden	m/s	0.32
5.2.1	Lifting speed unladen	m/s	0.34
5.3	Lowering speed laden	m/s	0.43
5.3.1	Lowering speed unladen	m/s	0.39
5.4	Nominal towing power laden	N	72000
5.4.1	Nominal towing power unladen	N	49000
5.5	Gradeability laden	%	>20
5.5.1	Gradeability unladen	%	>20
5.6	Acceleration time laden	s	-
5.7	Service brake		Hydraulic

Motors

Table 35. Motors

	Designation	Unit	Value
6.1	Engine manufacture / type		Deutz TCD 3.6 L4 □EU Stage V□
6.2	Engine power acc. To ISO 1585	KW	85
6.3	Rated speed	tr/min	2200
6.4	No. Of cylinders / displacement	cm3	4 / 3621
6.5	Fuel consumption acc. To VDI cycle	L/h	10.2

Miscellaneous

Table 36. Miscellaneous

	Designation	Unit	Value
7.1	Hydraulic pressure for attachments	Bar	195
7.2	Oil volume for attachments	L/min	155
7.3	Sound level at driver's ear according to DIN 12053 (overhead guard / cab)	dB (A)	84
7.4	Towing coupling design / DIN type	-	-
7.5	Average weighted acceleration on driver's body (according to standard NF EN 13059)	m/s ²	1.2

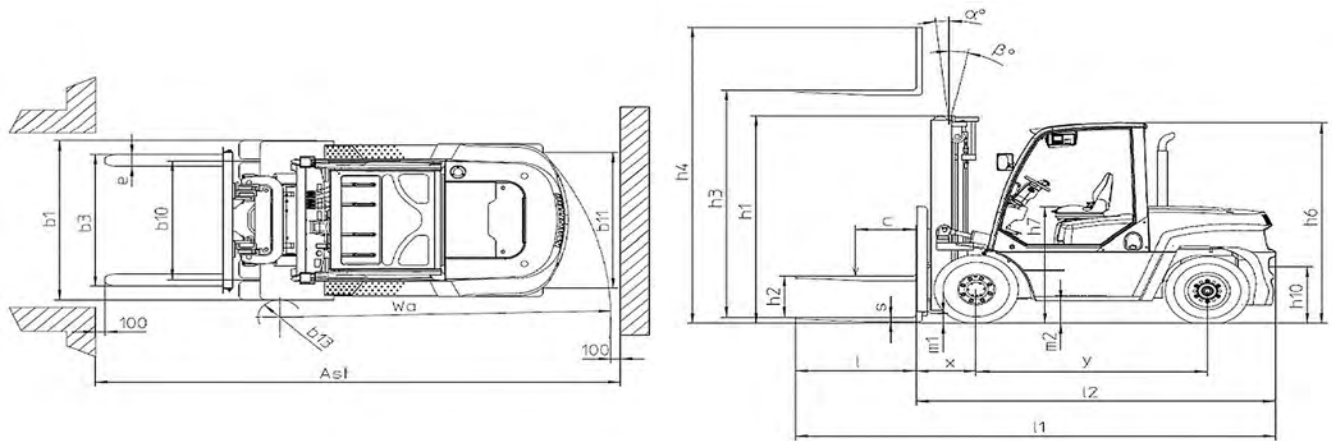

Figure 10: Dimensions diagram

2.5.6 MAST TECHNICAL DATASHEET - MI 50L→60 D D ST5 S1

Mast specifications MI 50L→60 D D ST5 S1

Table 37. Mast specifications MI 50L→60 D D ST5 S1

	Mast fork height (mm)	Free lift H2	Height - mast lowered H1	Height - mast extended with backrest H4	Height mast extended without backrest H4	Tilt range - AV - FWD	Tilt range - AV - FWD
2 Stage wide-view	3000	160	2500	4407	3995	6°	12°
	3300	160	2650	4707	4295	6°	12°
	3600	160	2800	5007	4595	6°	12°
	4000	160	3000	5407	4995	6°	12°
	4500	160	3300	5907	5500	6°	6°
2 Stage full-free-lift	5000	160	3550	6407	6000	6°	6°
	3000	1495	2450	4137	3955	6°	12°
	3300	1645	2600	4437	4255	6°	12°
	3600	1795	2750	4737	4555	6°	12°
3 Stage full-free-lift	4000	1995	2950	5137	4955	6°	12°
	4500	1500	2725	5907	5735	6°	6°
	4800	1600	2825	6207	6035	6°	6°
	5000	1672	2875	6407	6213	6°	6°
	5500	1800	3075	6907	6785	3°	6°
	6000	2000	3225	7407	7235	3°	6°

Capacity with forks MI 50L→60 D D ST5 S1

Table 38. Capacity with forks MI 50L→60 D D ST5 S1

	Height at max capacity (mm)		Load capacity at 500mm (KG)	
	5 T	6 T	5 T	6 T
2 Stage wide-view	3000	3000	5000	6000
	3300	3300	5000	6000
	3600	3600	5000	6000

	Height at max capacity (mm)		Load capacity at 500mm (KG)	
	5 T	6 T	5 T	6 T
	4000	4000	5000	6000
	4500	4500	5000	6000
	5000	5000	5000	6000
2 Stage full-free-lift	3000	3000	5000	6000
	3300	3300	5000	6000
	3600	3600	5000	6000
	4000	4000	5000	6000
3 Stage full-free-lift	4500	4500	4500	5500
	4800	4800	4500	5500
	5000	5000	4500	5500
	5500	5500	4200	5200
	6000	6000	4000	5000

Capacity with side-shift MI 50L→60 D D ST5 S1

Table 39. Capacity with side-shift MI 50L→60 D D ST5 S1

	Height at max capacity (mm)		Load capacity at 500mm (KG)	
	5 T	6 T	5 T	6 T
2 Stage wide-view	3000	3000	4500	5500
	3300	3300	4500	5500
	3600	3600	4500	5500
	4000	4000	4500	5500
	4500	4500	4500	5500
	5000	5000	4500	5500
2 Stage full-free-lift	3000	3000	4500	5500
	3300	3300	4500	5500
	3600	3600	4500	5500
	4000	4000	4500	5500
3 Stage full-free-lift	4500	4500	4000	5000
	4800	4800	4000	5000
	5000	5000	4000	5000
	5500	5500	3700	4700
	6000	6000	3500	4500

2.5.7 MAST TECHNICAL DATASHEET - MI 70 D D ST5 S1

Mast specifications MI 70 D D ST5 S1

Table 40. Mast specifications MI 70 D D ST5 S1

	Mast fork height (mm)	Free lift H2	Height - mast lowered H1	Height - mast extended with backrest H4	Height mast extended without backrest H4	Tilt range - AV - FWD	Tilt range - AV - FWD
2 Stage wide-view	3000	160	2500	4407	4167	6°	12°
	3300	160	2650	4707	4467	6°	12°
	3600	160	2800	5007	4767	6°	12°
	4000	160	3000	5407	5167	6°	12°
	4500	160	3300	5907	5667	6°	6°

	Mast fork height (mm)	Free lift H2	Height - mast lowered H1	Height - mast extended with backrest H4	Height mast extended without backrest H4	Tilt range - AV - FWD	Tilt range - AV - FWD
	5000	160	3550	6407	6167	6°	6°
2 Stage full-free-lift	3000	1335	2450	4137	4115	6°	12°
	3300	1485	2600	4437	4415	6°	12°
	3600	1635	2750	4737	4715	6°	12°
	4000	1835	2950	5137	5115	6°	12°
3 Stage full-free-lift	4500	1500	2725	5907	5735	6°	6°
	4800	1600	2825	6207	6035	6°	6°
	5000	1672	2875	6407	6213	6°	6°
	5500	1800	3075	6907	6785	3°	6°
	6000	2000	3225	7407	7235	3°	6°

Capacity with forks MI 70 D D ST5 S1

Table 41. Capacity with forks MI 70 D D ST5 S1

	Height at max capacity (mm)	Load capacity at 500mm (KG)
	7 T	7 T
2 Stage wide-view	3000	7000
	3300	7000
	3600	7000
	4000	7000
	4500	7000
	5000	7000
2 Stage full-free-lift	3000	7000
	3300	7000
	3600	7000
	4000	7000
3 Stage full-free-lift	4500	6400
	4800	6300
	5000	6300
	5500	6100
	6000	5500

Capacity with side-shift MI 70 D D ST5 S1

Table 42. Capacity with side-shift MI 70 D D ST5 S1

	Height at max capacity (mm)	Load capacity at 500mm (KG)
	7 T	7 T
2 Stage wide-view	3000	6500
	3300	6500
	3600	6500
	4000	6500
	4500	6500
	5000	6500
2 Stage full-free-lift	3000	6500
	3300	6500
	3600	6500
	4000	6500
3 Stage full-free-lift	4500	5900

	Height at max capacity (mm)	Load capacity at 500mm (KG)
	7 T	7 T
	4800	5800
	5000	5800
	5500	5600
	6000	5000

2.5.8 MAST TECHNICAL DATASHEET - MI 80 D D ST5 S1

Mast specifications MI 80 D D ST5 S1

Table 43. Mast specifications MI 80 D D ST5 S1

	Mast fork height (mm)	Free lift H2	Height - mast lowered H1	Height - mast extended with backrest H4	Height mast extended without backrest H4	Tilt range - AV - FWD	Tilt range - AV - FWD
2 Stage wide-view	3000	200	2700	-	4210	6°	12°
	3300	200	2850	-	4510	6°	12°
	3600	200	3000	-	4810	6°	12°
	4000	200	3200	-	5210	6°	12°
	4500	200	3500	-	5710	6°	6°
	5000	200	3750	-	6210	6°	6°
3 Stage full-free-lift	4500	1485	2750	-	5775	6°	6°
	4800	1585	2850	-	6075	6°	6°
	5000	1600	2950	-	6360	6°	6°
	5500	1800	3100	-	6810	3°	6°
	6000	1985	3250	-	7275	3°	6°

Capacity with forks MI 80 D D ST5 S1

Table 44. Capacity with forks MI 80 D D ST5 S1

	Height at max capacity (mm)	Load capacity at 500mm (Kg)
	8 T	8 T
2 Stage wide-view	3000	8000
	3300	8000
	3600	8000
	4000	8000
	4500	8000
	5000	8000
3 Stage full-free-lift	4500	7000
	4800	7000
	5000	6500
	5500	6100
	6000	5600

Capacity with side-shift MI 80 D D ST5 S1

Table 45. Capacity with side-shift MI 80 D D ST5 S1

	Height at max capacity (mm)	Load capacity at 500mm (Kg)
	8 T	8 T
2 Stage wide-view	3000	7600
	3300	7600
	3600	7600
	4000	7600
	4500	7600
	5000	7600
3 Stage full-free-lift	4500	6600
	4800	6600
	5000	6100
	5500	5700
	6000	5200

2.5.9 MAST TECHNICAL DATASHEET - MI 100 D D ST5 S1

Mast specifications MI 100 D D ST5 S1

Table 46. Mast specifications MI 100 D D ST5 S1

	Mast fork height (mm)	Free lift H2	Height - mast lowered H1	Height - mast extended with backrest H4	Height mast extended without backrest H4	Tilt range - AV - FWD	Tilt range - AV - FWD
2 Stage wide-view	3000	200	2850	-	4555	6°	12°
	3300	200	3000	-	4855	6°	12°
	3600	200	3150	-	5155	6°	12°
	4000	200	3350	-	5555	6°	12°
	4500	200	3650	-	6055	6°	6°
	5000	200	3900	-	6555	6°	6°
3 Stage full-free-lift	4500	1305	2850	-	6055	6°	6°
	4800	1405	2950	-	6355	6°	6°
	5000	1505	3050	-	6555	6°	6°
	5500	1655	3200	-	7055	3°	6°
	6000	1805	3350	-	7555	3°	6°

Capacity with forks MI 100 D D ST5 S1

Table 47. Capacity with forks MI 100 D D ST5 S1

	Height at max capacity (mm)	Load capacity at 500mm (Kg)
	10 T	10 T
2 Stage wide-view	3000	10 000
	3300	10 000
	3600	10 000
	4000	10 000
	4500	10 000
	5000	10 000
3 Stage full-free-lift	4500	8500

	Height at max capacity (mm)	Load capacity at 500mm (Kg)
	10 T	10 T
	4800	8500
	5000	8200
	5500	7700
	6000	7000

Capacity with side-shift MI 100 D D ST5 S1

Table 48. Capacity with side-shift MI 100 D D ST5 S1

	Height at max capacity (mm)	Load capacity at 500mm (Kg)
	10 T	10 T
2 Stage wide-view	3000	9600
	3300	9600
	3600	9600
	4000	9600
	4500	9600
	5000	9600
3 Stage full-free-lift	4500	8100
	4800	8100
	5000	7800
	5500	7300
	6000	6600

2.5.10 TIRES – MI 50L D D ST5 S1

Table 49. Front tires

		Pressure (bar)	Load per tire (Kg)	
			Unladen	Laden
ADVANCE	8.25-15-14PR PPS JUM	-	2150	6100
	8.25-15-14PR JUM	-		

Table 50. Rear tires

		Pressure (bar)	Load per tire (Kg)	
			Unladen	Laden
ADVANCE	8.25-15-14PR PPS	-	2250	800
	8.25-15-14PR	-		

2.5.11 TIRES – MI 60 D D ST5 S1

Table 51. Front tires

		Pressure (bar)	Load per tire (Kg)	
			Unladen	Laden
ADVANCE	8.25-15-14PR PPS JUM	-	2050	6650
	8.25-15-14PR JUM	-		

Table 52. Rear tires

		Pressure (bar)	Load per tire (Kg)	
			Unladen	Laden
ADVANCE	8.25-15-14PR PPS	-	2550	950
	8.25-15-14PR	-		

2.5.12 TIRES – MI 70 D D ST5 S1

Table 53. Front tires

		Pressure (bar)	Load per tire (Kg)	
			Unladen	Laden
ADVANCE	8.25-15-14PR PPS JUM	-	2050	7650
	8.25-15-14PR JUM	-		

Table 54. Rear tires

		Pressure (bar)	Load per tire (Kg)	
			Unladen	Laden
ADVANCE	8.25-15-14PR PPS	-	3000	900
	8.25-15-14PR	-		

2.5.13 TIRES – MI 80 D D ST5 S1

Table 55. Front tires

		Pressure (bar)	Load per tire (Kg)	
			Unladen	Laden
ADVANCE	9.00-20-14PR PPS JUM	-		
	9.00-20-14PR JUM	-		

Table 56. Rear tires

		Pressure (bar)	Load per tire (Kg)	
			Unladen	Laden
ADVANCE	9.00-20-14PR PPS	-		
	9.00-20-14PR	-		

2.5.14 TIRES – MI 100 D D ST5 S1

Table 57. Front tires

		Pressure (bar)	Load per tire (Kg)	
			Unladen	Laden
ADVANCE	9.00-20-14PR PPS JUM	-		
	9.00-20-14PR JUM	-		

Table 58. Rear tires

		Pressure (bar)	Load per tire (Kg)	
			Unladen	Laden
ADVANCE	9.00-20-14PR PPS	-		
	9.00-20-14PR	-		

2.5.15 GROUND CONTACT PRESSURE - MI 50L → 100 D D ST5 S1

Table 59. ADVANCE tires

	Pressure (bar)	Load (Kg)	Ground contact pressure (Kg/cm ²)		Ground contact area (cm ²)	
			Hard ground	Soft ground	Hard ground	Soft ground
8.25-15-14PR PPS JUM	-	2050				
		2150				

	Pressure (bar)	Load (Kg)	Ground contact pressure (Kg/cm ²)		Ground contact area (cm ²)	
			Hard ground	Soft ground	Hard ground	Soft ground
		6100				
		6650				
		7650				
8.25-15-14PR JUM	-	2050				
		2150				
		6100				
		6650				
		7650				
8.25-15-14PR PPS	-	800				
		900				
		950				
		2250				
		2550				
		3000				
8.25-15-14PR	-	800				
		900				
		950				
		2250				
		2550				
		3000				
9.00-20-14PR PPS JUM	-					
9.00-20-14PR JUM	-					
9.00-20-14PR PPS	-					
9.00-20-14PR	-					

2.5.16 LOAD CHART

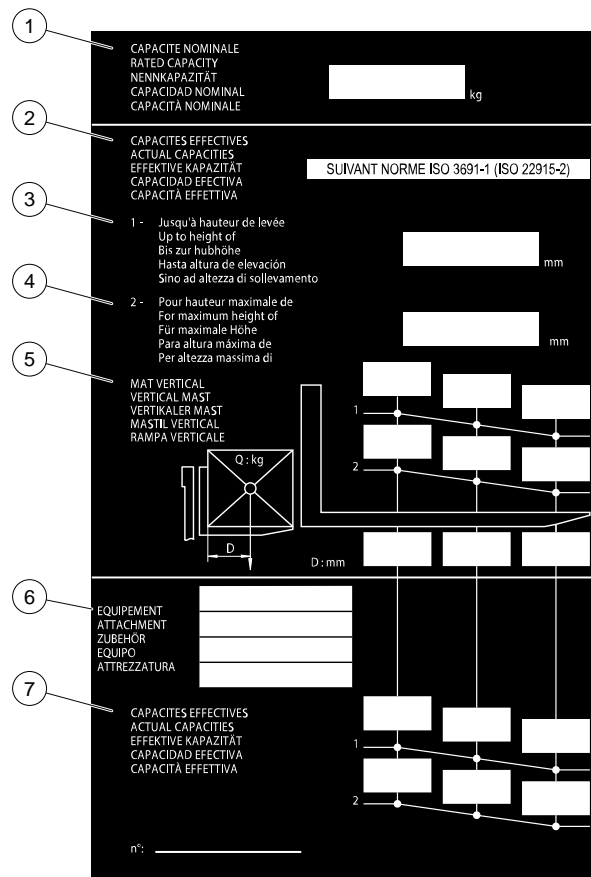

Figure 11: Load chart informations

Marker	Description
1	Rated capacity
2	Actual capacities According to standard ISO 3691-1 (ISO 22915-2)
3	Up to lift height
4	For maximum height of
5	Vertical mast
6	Equipment
7	Actual capacities

2.6. MACHINE COMPONENTS

2.6.1 COMPONENTS LOCATION – MI 50L→100 D D ST5 S1

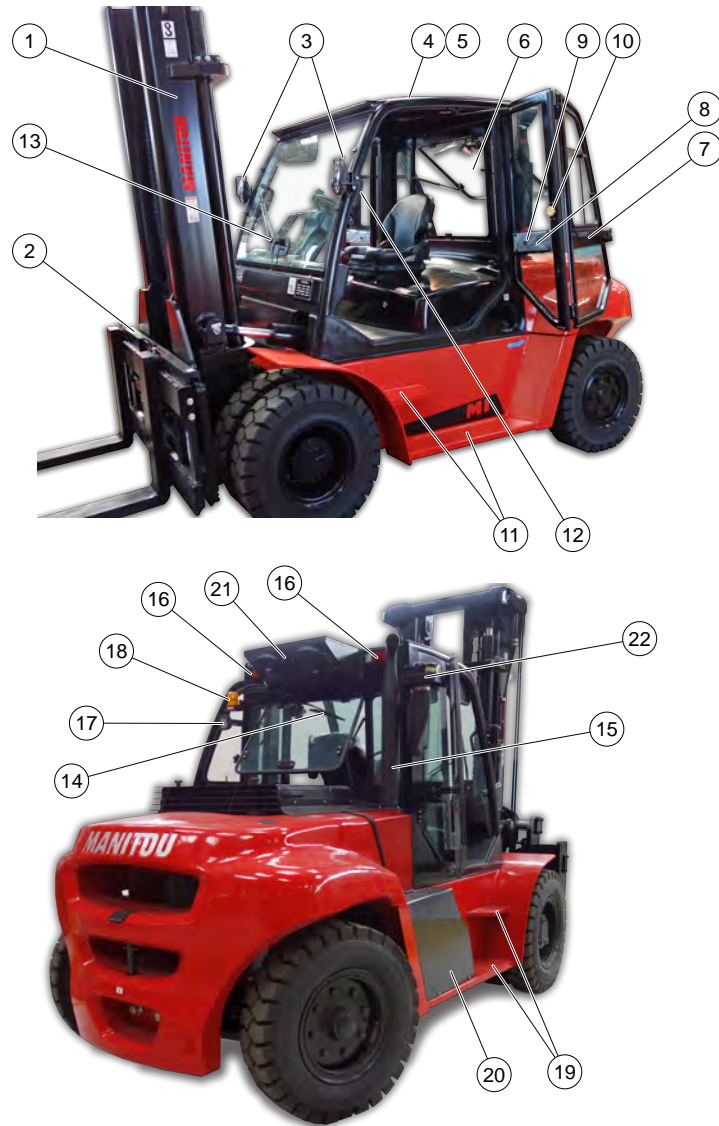

Figure 12: Components location – MI 50L→100 D D ST5 S1

Table 60. List of components – MI 50L→100 D D ST5 S1

Marker	Description	Option
1	Mast	
2	Fork carriage	
3	Front headlights	
4	Overhead guard	
5	Driver's cab	•
6	Rear window	•
7	First side door panel	•
8	Second side door panel	•

Marker	Description	Option
9	Release button for closing the first side door leaf	•
10	Release knob for opening the second side door leaf	•
11	Leftside steps	
12	Driving seat access handle	
13	Front windscreen wiper	•
14	Rear windscreen wiper	•
15	Exhaust pipe	
16	Rear lights	
17	Rear working light	
18	Rotating beacon light	
19	Rightside steps	
20	DEF tank (MI 80→100 D D ST5 S1 only)	
21	Air conditioning unit	•
22	Cyclonic air pre-filter	•

2.6.2 DRIVER'S CAB COMPONENTS
LOCATION – MI 50L→100 D D ST5
S1



Figure 13: Driver's cab components location – MI 50L→100 D D ST5 S1

Table 61. List of driver's cab components – MI 50L→100 D D ST5 S1







Marker	Description	Option
1	Forward/Neutral/Reverse gear selector	
2	Steering wheel	
3	Horn	
4	Ignition switch	
5	Lighting and indicator switch	
6	Lifting hydraulic control lever	
7	Tilting hydraulic control lever	
8	Fork carriage side-shift hydraulic control or Attachment hydraulic control	
9	Emergency stop	

Marker	Description	Option
10	Parking brake lever	
11	Transmission cut-off pedal	
12	Service brake	
13	Accelerator pedal	
14	Switches	
15	Cup holder	
16	Heating control components	•
17	Driver's seat	
18	Internal rear-view mirror	
19	Display	
20	Transmission mode selection switch	
21	Mini-lever armrest	•
22	Air conditioning & temperature adjusting rotary switch	•
23	Indicator light	•
24	Fan speed rotary switch	•

2.7. DISPLAY & CONTROLS

2.7.1 MACHINE SWITCHES AND INDICATOR LIGHTS

Table 62. List of machine switches and indicator lights

Description		Option
Rotating beacon		
Rear working light		
Front working light		
Front windscreen wiper		•
Rear windscreen wiper		•
Front windscreen washer		•
Seatbelt		

2.7.2 MINI-LEVERS CONTROLS

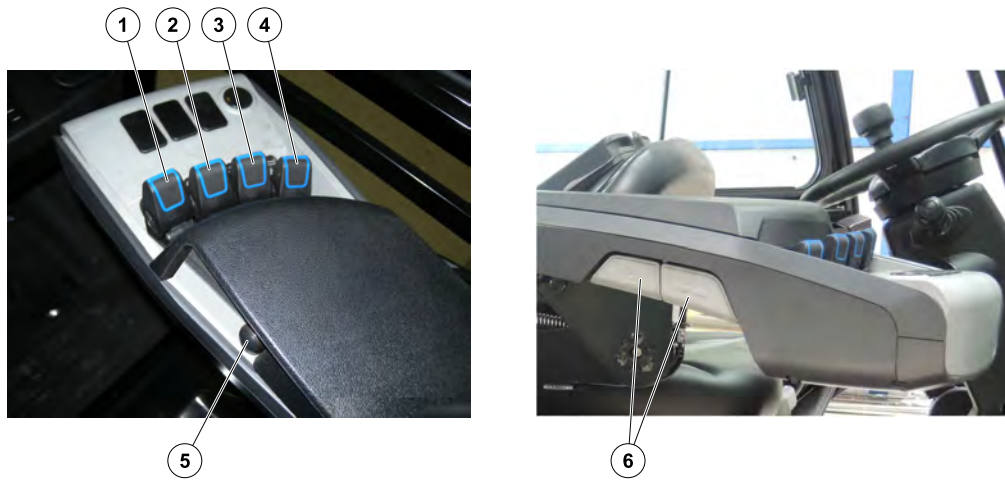

Figure 14: Mini-levers controls

Table 63. List of mini-levers controls

Marker	Description	Option
1	Fork lifting hydraulic	•
2	Mast tilting hydraulic	•
3	Fork carriage side-shift hydraulic	•
4	Hydraulic attachment	•
5	Horn	•
6	Armrest adjustment	•

2.7.3 PV380 CONTROL PANEL

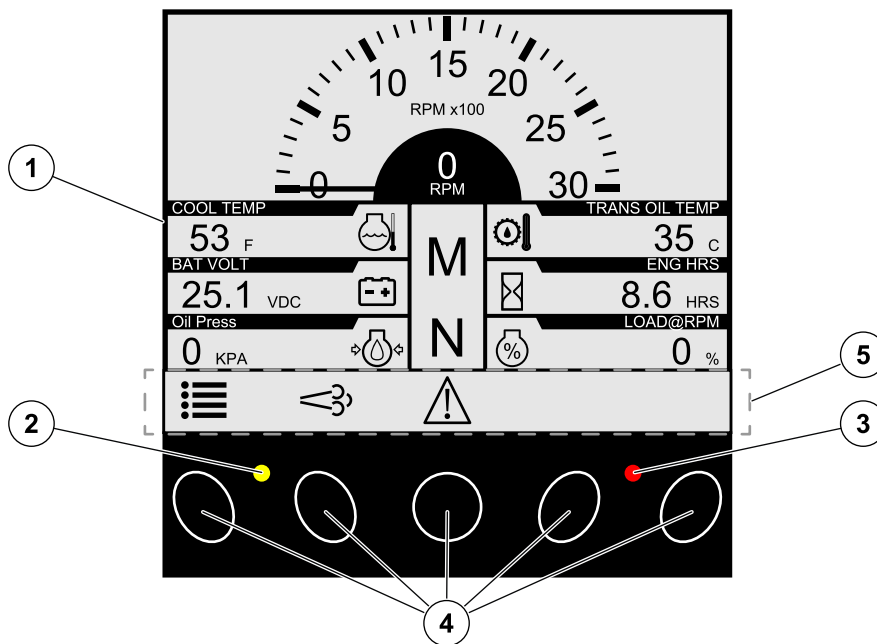







Figure 15: Control panel's components location

Table 64. List of control panel's components

Marker	Designation	Description
1	Display screen	Turned on : machine powered
2	Yellow indicator light	Turned on / Flashing : fault alert
3	Red indicator light	Turned on / Flashing : major fault alert ; engine must be shutdown
4	Display screen control keys	Briefly pressed : activate the control corresponding to the pictogram displayed on the Navigation & control bar (6)
5	Navigation & control bar	Briefly press a display screen control key to display Navigation & control bar
5	Yes	Confirm the request
5	Ok	Confirm the selection
5	Inhibit	Not active
5	Cancel	Cancel the request
5	Settings menu	 Access to dashboard settings adjustment menu
5	Next	 Access to next page/row
5	DPF menu	 Access to "DPF" regeneration menu
5	Previous	 Access to previous page/row
5	Faults menu	 Access to fault code display menu
5	Plus	+ Adjust the setting
5	Minus	- Adjust the setting
5	Exit	 Return to work page

2.7.4 PV380 WORK PAGE

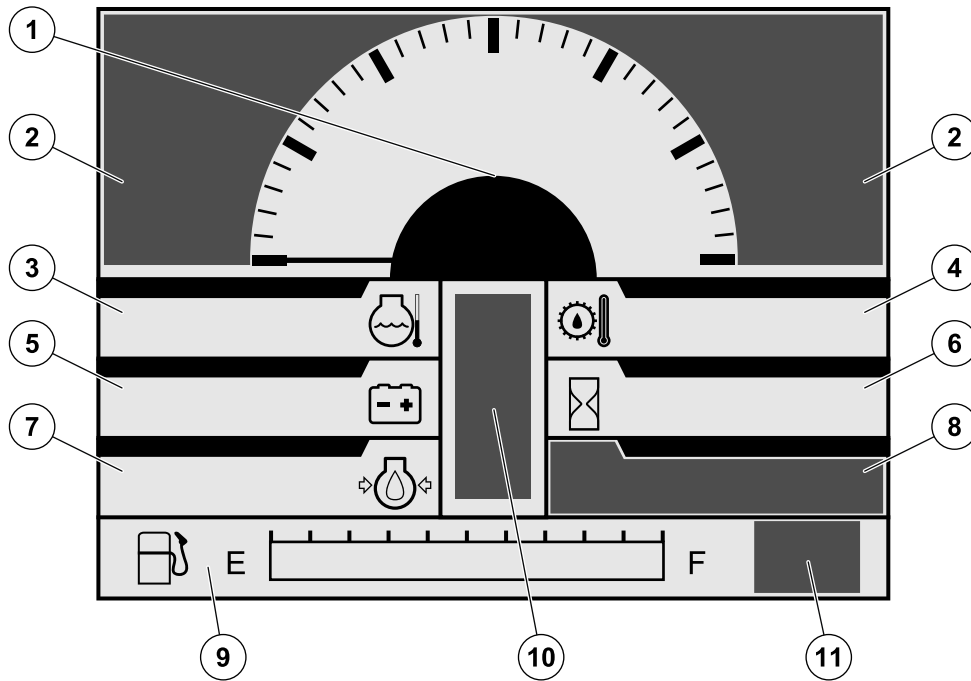































Figure 16: Indicator lights & pictograms location

Table 65. List of indicator lights & pictograms location

Marker	Designation	Description
1	Rev counter	Engine speed (RPM)
2	Engine fault indicator light	 Turned on : engine fault
2	"DEF" fault indicator light	 Turned on : Low "DEF" (Diesel Exhaust Fluid) level  Not used for the machines MI 50 L→70 D D ST5 S1
2	Preheat indicator light	 Turned on : diesel engine preheat in progress
2	Brake system low pressure indicator light	 Turned on : brake system low pressure fault
2	STOP indicator light	 Turned on : major engine fault ; engine must be powered down
2	Restricted DPF regeneration indicator light	 Turned on : DPF (Diesel Particulate Filter) regeneration cannot be started  Only for the machines MI 50 L→70 D D ST5 S1
2	Regeneration "SCR" fault indicator light	 Turned on : Regeneration "SCR" (Selective Catalytic Reduction) fault ; engine must be powered down  Only for the machines MI 80→100 D D ST5 S1
2	Gas temperature fault indicator light	 Turned on : gas temperature fault
2	Air filter clogging indicator light	 Turned on : air filter clogging fault

Marker	Designation		Description
2	DPF saturation indicator light		Turned on : DPF (Diesel Particulate Filter) saturation fault  Only for the machines MI 50 L→70 D D ST5 S1
2	"SCR" saturation indicator light		Turned on : "SCR" (Selective Catalytic Reduction) saturation fault  Only for the machines MI 80→100 D D ST5 S1
2	Regeneration "SCR" shutdown indicator light		Turned on : Regeneration "SCR" (Selective Catalytic Reduction) fault ; engine must be powered down  Not used for the machines MI 50 L→70 D D ST5 S1
3	Engine coolant temperature		Temperature value (°C or °F)
4	Transmission oil temperature		Temperature value (°C or °F)
5	Battery charge level		Battery voltage value (Vdc)
6	Hour meter		Engine operating hours (Hrs)
7	Engine oil pressure		Pressure value (Bar or PSI)
8	Engine load		Engine load rate (%)  Only for the machines MI 50 L→70 D D ST5 S1
8	Diesel Exhaust Fluid "DEF" level		"DEF" tank filling rate (%)  Only for the machines MI 80→100 D D ST5 S1
9	Fuel level		<ul style="list-style-type: none"> • E : Tank empty • F : Tank full
10	Manual transmission mode	M	Displayed : mode activated
10	Automatic transmission mode	A	Displayed : mode activated
10	Forward slow speed gear mode	F1	Displayed : mode activated
10	Forward intermediate speed gear mode	F2	Displayed : mode activated
10	Forward fast speed gear mode	F3	Displayed : mode activated
10	Neutral gear mode	N	Displayed : mode activated
10	Reverse slow speed gear mode	R1	Displayed : mode activated
10	Reverse intermediate speed gear mode	R2	Displayed : mode activated
10	Reverse fast speed gear mode	R3	Displayed : mode activated
11	Parking brake		Turned on : parking brake activated
	Warning indicator light	!	Turned on : critical value

2.7.5 PV380 DASHBOARD SETTING ADJUSTMENT MENU

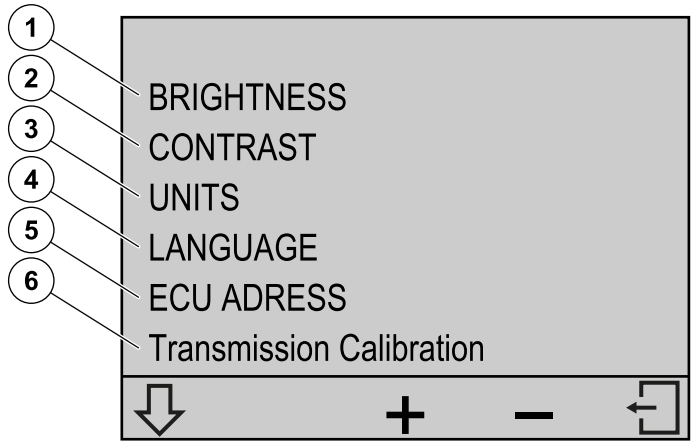

Figure 17: Dashboard setting adjustment menu page

Table 66. List of setting

Marker	Designation	Description
1	BRIGHTNESS	Screen brightness adjustment
2	CONTRAST	Screen contrast adjustment
3	UNITS	Choice of the screen unit
4	LANGUAGE	Choice of the screen language
5	ECU ADRESS	ECU address Information (cannot be changed)
6	Transmission calibration	Calibration menu access denied, consult your dealer

2.7.6 PV380 FAULTS DISPLAY MENU

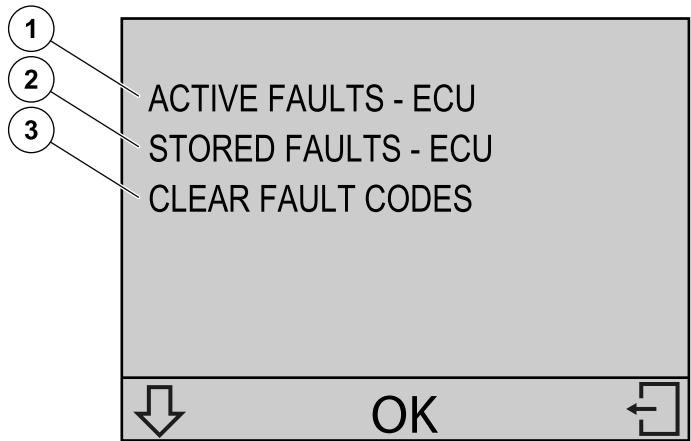

Figure 18: Faults display menu page

Table 67. List of controls

Marker	Designation	Description
1	ACTIVE FAULTS – ECU	Access to list of active faults
2	STORED FAULTS – ECU	Access to list of stored faults
3	CLEAR FAULT CODES	Clear fault codes

3. MACHINE OPERATION

3.1. INSTALLATION AT THE DRIVER'S CAB

3.1.1 GETTING ON/OFF THE MACHINE

⚠ CAUTION

Risk of injury

Do not jump out of the lift truck.

NOTICE

Risk of machine damage

Do not use the steering wheel as point of support.

Always face the lift truck when getting into and out of the driver's cab.

Always enter the driver's cab on the left side of the machine.

Make sure that you always have 3 points of support when getting in and out of the driver's cab.

- Use the driving seat access handle.
- Use the step.
- Use either the engine cover, the driver's seat or the overhead guard as third point of support.

3.1.2 ADJUSTING THE SEAT

⚠ CAUTION

Risk of injury and crushing the hand

Support the back-rest when adjusting the seat.

Be careful when adjusting the seat.

The driver is sitting on the driver's seat.

Weight adjustment

1. Pull the weight adjustment lever fully out.

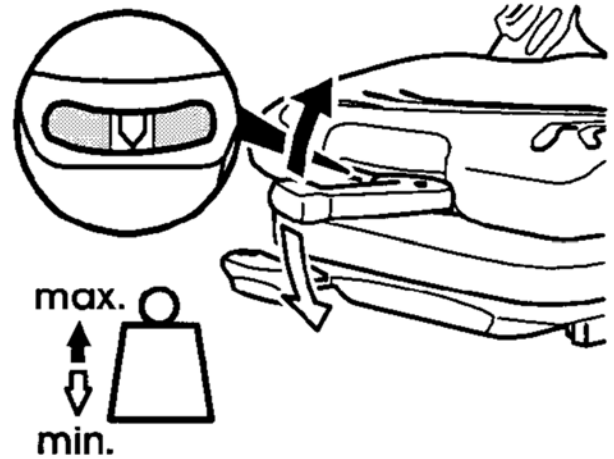

Figure 19: Driver's seat weight adjustment

2. Move the weight adjustment lever up to increase the weight or down to reduce it.



There are ten possible positions between the min. and max. weights.

Before each run, return the lever to the central position.

The max. or min. position is indicated by a freely traveling lever.

The driver's weight is correctly adjusted when the arrow is in the center of indicator.

3. After completing weight adjustment, fully lower the lever.

Longitudinal adjustment

- Adjust the locking lever until you reach the position required.

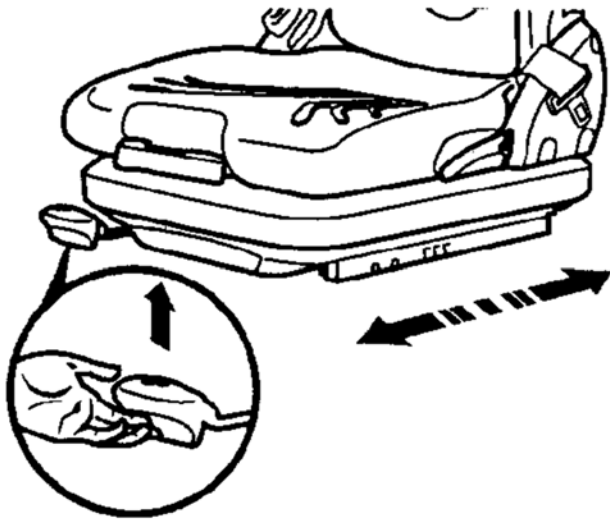

Figure 20: Driver's seat longitudinal adjustment

Lumbar adjustment

- Turn knob to 1 to adjust the height and depth of the lumbar support of the upper part of the back-rest.
- Turn knob to 2 to adjust the height and depth of the lumbar support of the lower part of the back-rest.

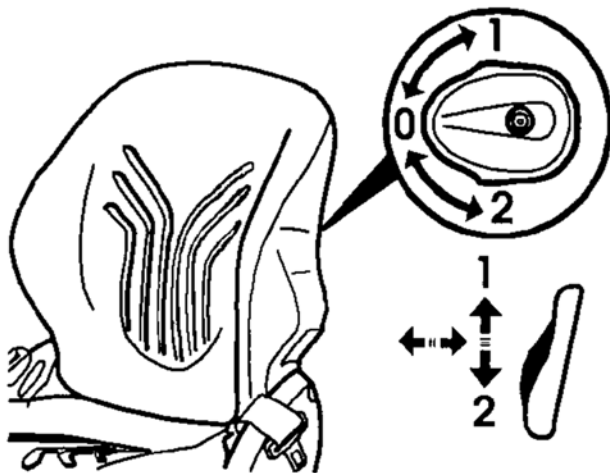

Figure 21: Driver's seat lumbar adjustment

Angle adjustment of the back-rest

1. Support the back-rest.
2. Pull the lever and adjust the back-rest to find the desired position.

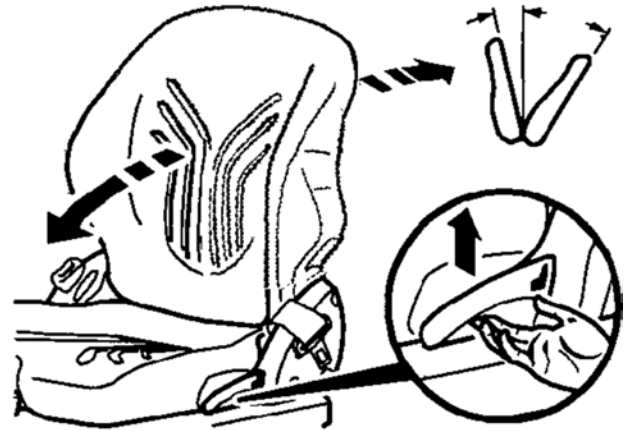

Figure 22: Driver's seat angle adjustment of the back-rest

3.1.3 ADJUSTING THE STEERING WHEEL

1. Pull out the steering wheel tilting knob to adjust the position of the steering wheel.
2. Push back in the steering wheel tilting knob to lock the steering wheel in the desired position.

3.1.4 ADJUSTING THE ARMREST

The armrest is adjustable in height and length.

- Press the button (1) to adjust in height.
- Press the button (2) to adjust in length.



Figure 23: Buttons to adjust the armrest

3.1.5 FASTENING THE SEAT BELT

⚠ DANGER

In no event should the lift truck be used if the seat belt is defective (fixing, locking, cuts, tears, etc.).

Repair or replace the seat belt immediately.

1. Sit correctly on the seat.
2. Check that seat belt is not twisted.
3. Place the seat belt at hip level.
4. Attach the seat belt and check that it locks.
5. Adjust the seat belt to your body shape without squeezing your hip and without over-slack.

3.2. OPERATING THE MACHINE

3.2.1 OPERATING THE MACHINE WITH THE OPERATOR PRESENCE SYSTEM

If the parking brake is released without operator on the seat, a sound alarm will be heard.

If the operator leaves the seat over 2 seconds in the process of handling, a sound alarm will be heard and the handling operation will automatically stop.

Lift truck from 2023–04–15:

If the operator has not fastened the seatbelt when the parking brake is released or in the process of handling, a sound alarm will be heard.

If the operator unfastens the seatbelt and leaves the seat in the process of handling, a sound alarm will be heard and the handling operation will automatically stop.

- Moving the machine forwards or backwards:
 1. Sit down correctly in the driver's seat and fasten the seatbelt
 2. Release the parking brake
 3. Engage forward or reverse movement
- Stopping the machine:
 1. Set the forward/reverse selector to neutral
 2. Apply the parking brake
 3. Unfasten the seatbelt and get off the machine

3.2.2 POWERING UP THE MACHINE

The forward/reverse selector is in neutral position (lamp is lit), the ignition switch is in position (1) and the machine is stationary.

1. Turn the ignition switch to the preheating position (2) for a few seconds until the lamp goes out.

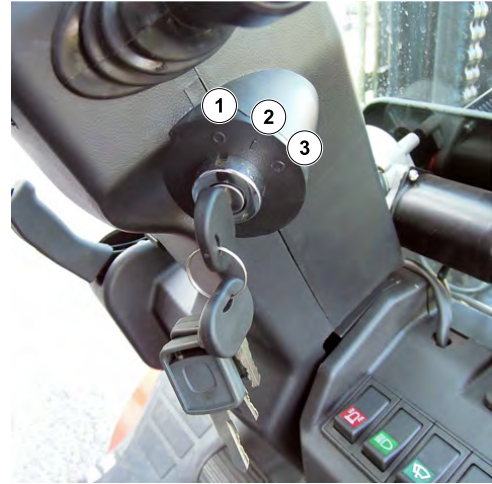

Figure 24: Ignition switch positions

2. Turn the ignition switch to the position (3) to start the engine.

The machine is powered up and the ignition switch is in position (2).

3.2.3 POWERING DOWN THE MACHINE

NOTICE

Risk of depollution system damage (Only for MI 80/100 D D ST5 S1)

Switch off the ignition with the key, wait for 5 minutes in order to purge the Diesel Exhaust Fluid (DEF) system, then operate the emergency stop button

The forward/reverse selector is in neutral position (lamp is lit), the ignition switch is in position (2) and the machine is stationary.

1. Turn the ignition switch to position (1).

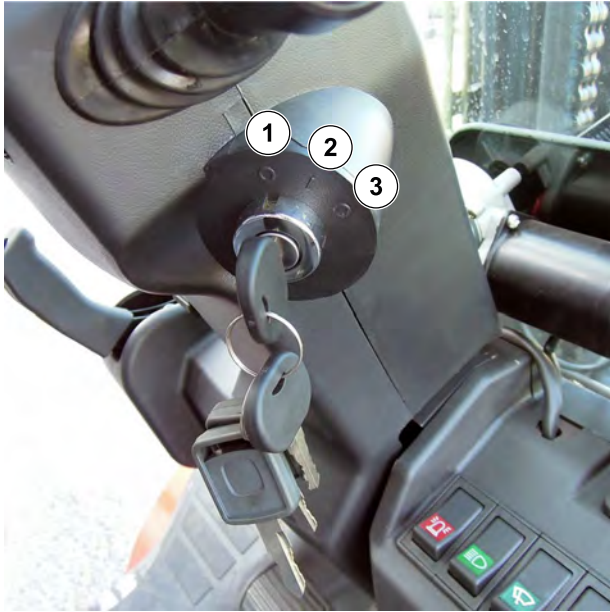

Figure 25: Ignition switch positions

2. Operate the emergency stop button.
The machine is powered down.

3.2.4 OPERATING THE HORN

- Press in the center of the steering wheel.
The horn will sound.

3.2.5 OPERATING THE HORN ON THE MINI-LEVERS

- Press on the button on the side of the mini-lever armrest.
The horn will sound.

3.2.6 OPERATING THE ROTATING BEACON

- Press on the rotating beacon switch to turn the light on and off.

3.2.7 OPERATING THE EMERGENCY STOP BUTTON

⚠ CAUTION

Risk of injury

Be ready for hydraulic movements suddenly stopping

NOTICE

Risk of engine damage

Do not use the emergency stop button to power down the machine

- Press the button to shut down the engine in case of danger.



Pull the button to disable it before restarting the machine.

3.2.8 OPERATING THE HEATER

- Press on the heater switch to turn the heating on and off.

3.2.9 OPERATING THE AIR CONDITIONING CONTROLS

- Turn the rotary switch (1) to adjust the fan speed



Figure 26: Air conditioning controls

- Turn the rotary switch (2) to turn on the air conditioning and to adjust the temperature
The indicator light comes on

3.2.10 DRIVING THE MACHINE

3.2.10.1 Operating the gear selector

Selecting gear mode and speed of movement

- Select the automatic or manual mode



Figure 27: Gear mode selection button



The selected mode is displayed on the dashboard screen.

- Turn the lever to position (1) to select slow speed

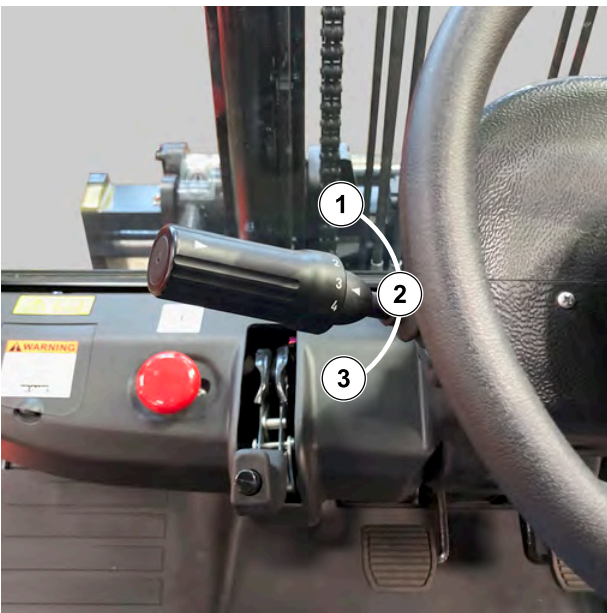

Figure 28: Speed of movement selection

- Turn the lever to position (2) to select intermediate speed
- Turn the lever to position (3) to select fast speed



In automatic mode, the gears are changed automatically up to the selected speed.

In manual mode, the movement of the machine only uses the selected speed.

Selecting the gear

NOTICE

Risk of transmission damage

Do not accelerate while changing gears.
Change gears at speeds below 1km/h.

The gear selector will not work unless the OPS system prerequisites are met.

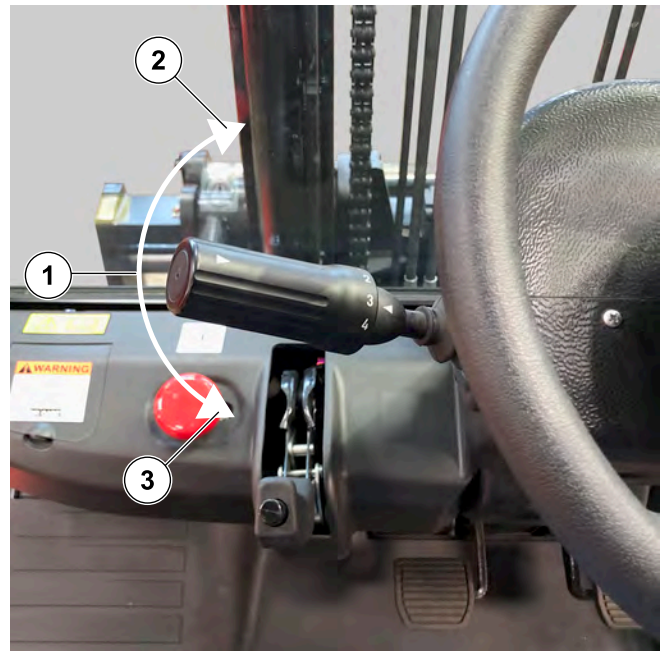

Figure 29: Gear selector

- Neutral position
 1. Stop the machine.
 2. Move the lever to position (1) to select the neutral position.
- Forward drive position
 1. Stop the machine.
 2. Pull lightly and push the lever upwards to select the forward drive position (2).
- Reverse drive position
 1. Stop the machine.
 2. Pull lightly and push the lever downwards to select the reverse drive position (3).
The reversing lights are on and the audible reverse warning is on.

◀ 3.2.1 Operating the machine with the operator presence system, page 61

3.2.10.2 Driving the machine

1. Get on the machine
2. Adjust the seat
3. Adjust the steering wheel
4. Fasten the seat belt
5. Release the parking brake
6. Power up the machine
7. Operate the gear selector to move forwards or backwards

◀ 3.2.10.1 Operating the gear selector, page 62

3.2.10.3 Operating the lights and indicators



Positions (2) and (3) can be used without switching on the ignition

- Put the Switch in position (1) and the lever in central position



Figure 30: Lights and indicators

- The lights and indicators are off
- Put the switch in position (2)
- The sidelights and the rear lights are on
- Put the switch in position (3)
- The headlights and the rear lights are on
- Push the lever (4) upwards
- The left hand indicator lights flash
- Push the lever (4) downwards
- The right hand indicator lights flash

3.2.10.4 Operating the windscreen wipers

- Press on the desired windscreen wiper switch



The location of the switches may vary depending on the options

The desired windscreen wipers are working

3.2.11 HANDLING A LOAD

3.2.11.1 Instructions for Handling a Load

Choice of Attachments

- Only attachments approved by MANITOU can be used on its lift trucks.
- Make sure the attachment is appropriate for the work to be done.
- Make sure the attachment is correctly installed and locked onto the lift truck carriage.
- Make sure that your lift truck attachments work properly.
- Comply with the load chart limits for the lift truck for the attachment used.
- Do not exceed the rated capacity of the attachment.
- Never lift a load in a sling without the attachment provided for the purpose. There are optional solutions; contact your

Weight of Load and Centre of Gravity

⚠ WARNING

It is forbidden to move a load heavier than the effective capacity defined on the lift truck load chart.

For loads with a moving centre of gravity (e.g. liquids), take account of the variations in the centre of gravity in order to determine the load to be handled and be extra vigilant and careful to limit these variations as far as possible.

- Before taking up a load, you must know its mass and its centre of gravity.
- The load chart for your lift truck is valid for a load in which the longitudinal position of the centre of gravity is 500 mm or 600 mm from the base of the forks (according to the model of lift truck). For a higher centre of gravity, contact your dealer

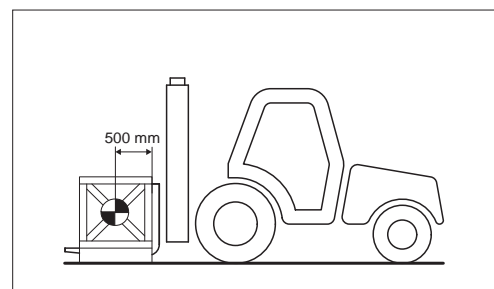

- For irregular loads, determine the transverse centre of gravity before any movement and set it in the longitudinal axis of the lift truck.

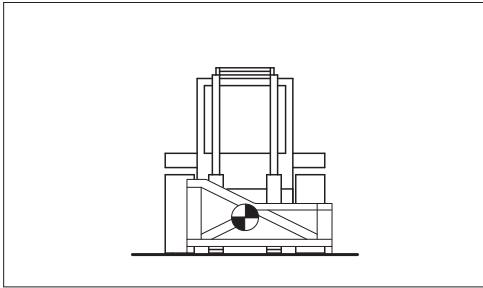

Transverse Attitude of the Lift Truck

The transverse attitude is the transverse slope of the chassis with respect to the horizontal.

Raising the mast reduces the lift truck's lateral stability. The transverse attitude must be set with the mast in down position as follows:

- Position the lift truck so that the bubble in the level is between the two lines.

Picking up a load on the ground

- Approach the lift truck perpendicular to the load, with the forks in a horizontal position.

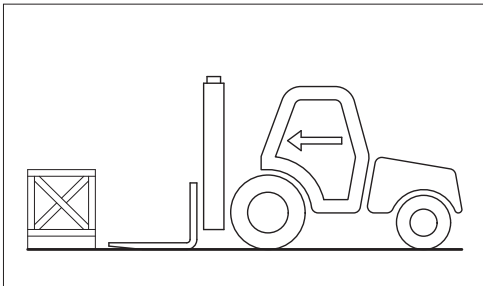

- Approach the lift truck perpendicular to the load, with the forks in a horizontal position.

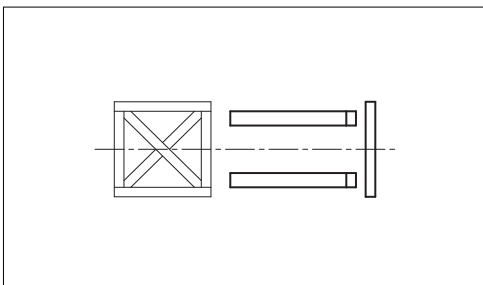

- Adjust the fork spread and centring in connection with the load (optional solutions exist, consult your dealer).

- Never lift a load with a single fork.

⚠ WARNING

Beware of the risks of trapping or crushing limbs when manually adjusting the forks.

- Move the lift truck forward slowly (1) and bring the forks to stop in front of the load, if necessary, slightly lift the mast (2) while taking up the load.
- Bring the load into the transport position.
- Tilt the load far enough backwards to ensure stability (loss of load on braking or going downhill).

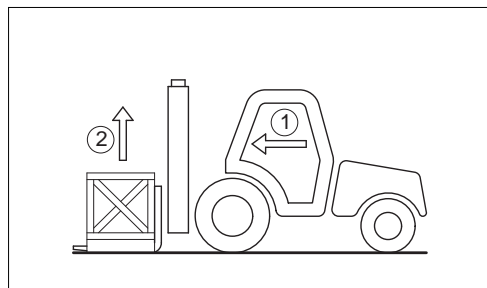

FOR A NON-PALLETISED LOAD

- Tilt the carriage (1) forwards and move the lift truck slowly forwards (2), to insert the fork under the load (block the load if necessary).
- Continue to move the lift truck forwards (2) tilting the carriage (3) backwards to position the load on the forks and check the load's longitudinal and lateral stability.

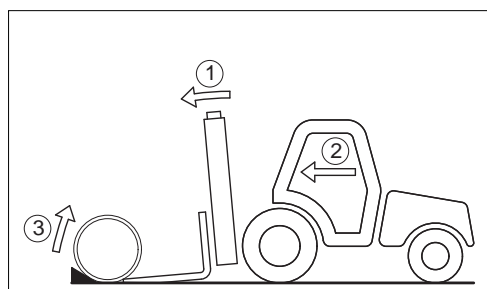

Picking up and laying down a high load on tires

⚠ DANGER

You must not raise the boom if you have not checked the transverse attitude of the lift truck.

Remember: Make sure that the following operations can be performed with good visibility.

PICKING UP A HIGH LOAD ON TYRES

1. Ensure that the forks will easily pass under the load.
2. Keeping the mast vertical (1), advance the lift truck and raise the forks to level with the load (2) .

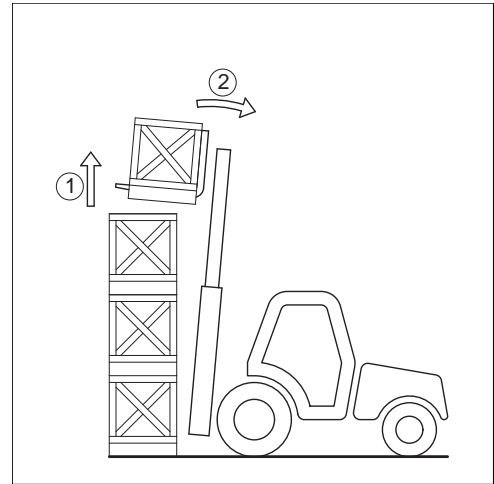
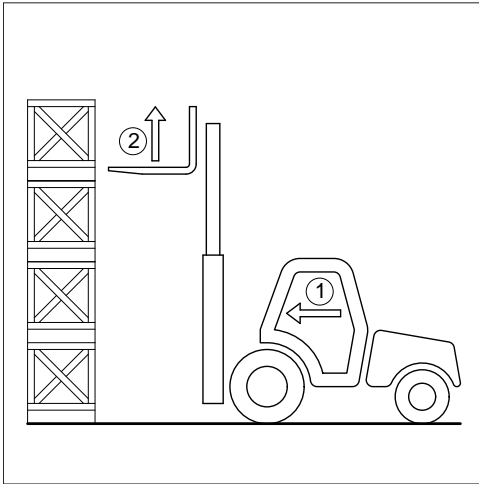

5. Tilt the load sufficiently backwards to ensure its stability.
6. Reverse the lift truck (1) very carefully and gently to free the load. Lower the mast (2) to bring the load into transport position.

3. Manoeuvre carefully and gently to bring the forks to the stop in front of the load. Set the handbrake and place the forward/reverse selector to neutral.

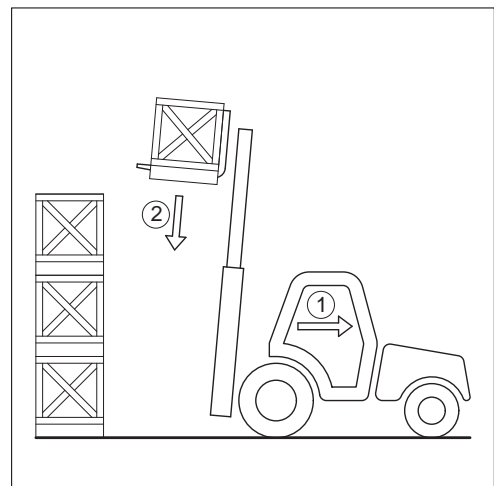
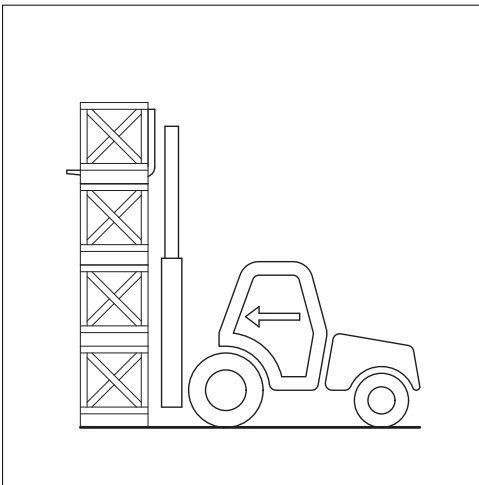

LAYING A HIGH LOAD ON TYRES

1. Approach the load in the transport position in front of the pile.

4. Slightly raise the load (1) and tilt the carriage (2) backwards to stabilise the load.

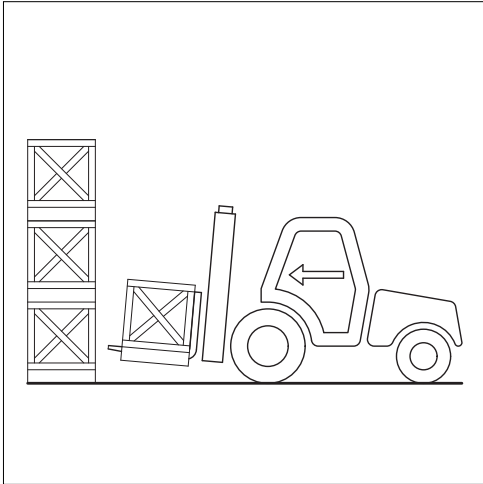

2. Raise the mast (1) until the load is higher than the pile and move the lift truck forward (2) very carefully and gently, until the load is over the pile. Put the handbrake on and set the forward/reverse selector to neutral.

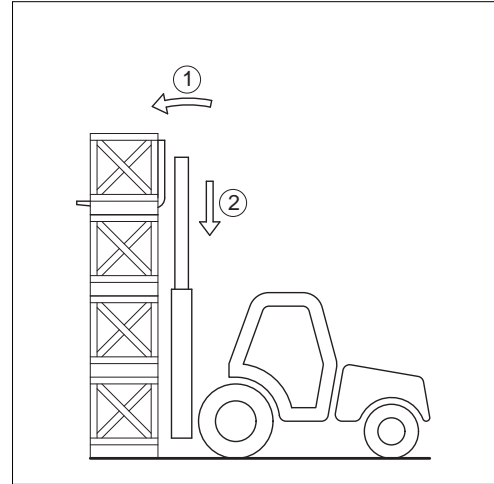

4. Reverse the lift truck (1) very slowly and carefully to release the forks. Then set them into transport position.

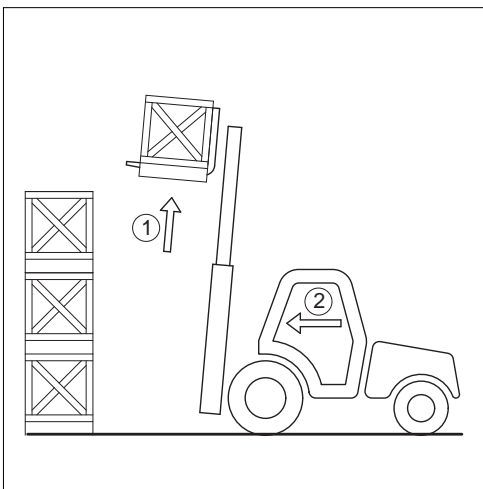

3. Place the load in a horizontal position by tilting the mast forwards (1) and lay it down on the pile (2) while checking the correct positioning of the load .

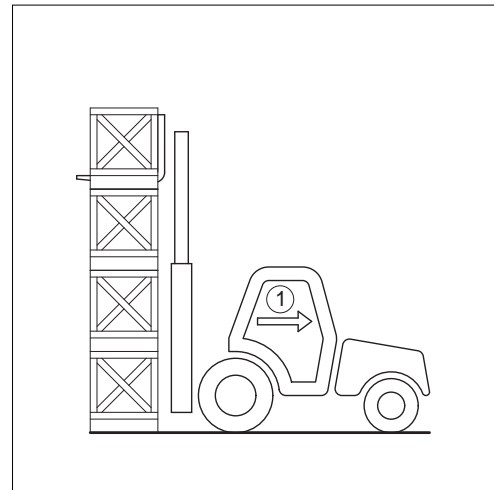

3.2.11.2 Using the hydraulic controls

⚠ WARNING

Machine shaking

Risk of accident

Use the hydraulic controls without jerking

The gear selector will not work unless the OPS system prerequisites are met.

The driver is sat on the seat

Lifting the load

- Move the lever (1) backwards to lift the load

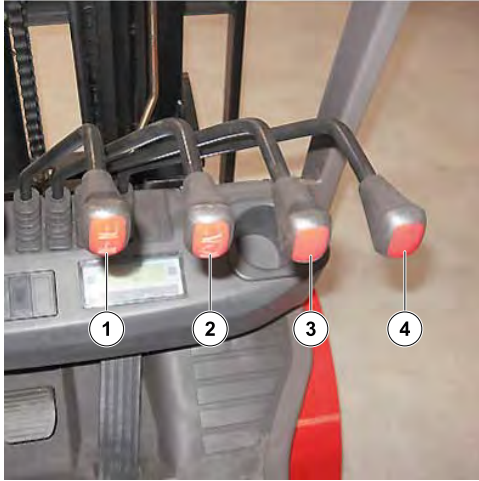

Figure 31: Hydraulic controls

- Move the lever (1) forwards to lower the load

Tilting the mast

- Move the lever (2) backwards to tilt the mast backwards
- Move the lever (2) forwards to tilt the mast forwards

Carriage side-shift

- Move the lever (3) backwards to move sideways to the right
- Move the lever (3) forwards to move sideways to the left

Attachment

- Move the lever (3) forwards or backwards

Additional accessory

- Move the lever (4) forwards or backwards

◀ 3.2.1 *Operating the machine with the operator presence system*, page 61

3.2.11.3 Adjusting the fork spacing

The machine must be unloaded

1. Pull up the adjusting knob and turn it 180 degrees to unlock the fork

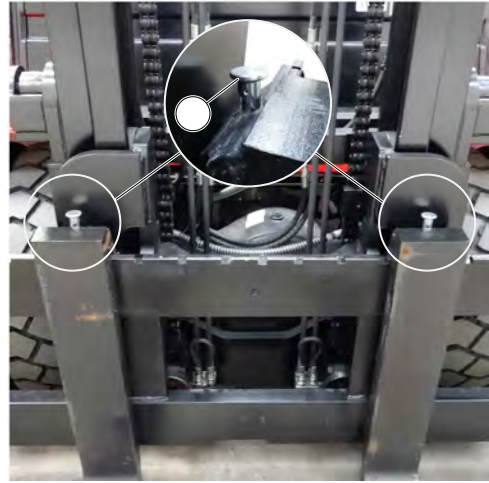

Figure 32: Fork spacing adjustment

2. Slide the forks to the left or the right to adjust them
3. Turn the adjusting knob 180 degrees and push it down to lock the fork

3.2.12 MANAGEMENT OF THE POLLUTION CONTROL SYSTEM

3.2.12.1 Starting the parked regeneration

⚠ DANGER

Risk of suffocation

Park the machine in a safe and adequately ventilated place

NOTICE

Risk of engine damage

Do not stop the exhaust regeneration unless it's absolutely necessary

Do not use any machine functions while the exhaust regeneration is in progress

The DPF saturation indicator light is lit on the work page

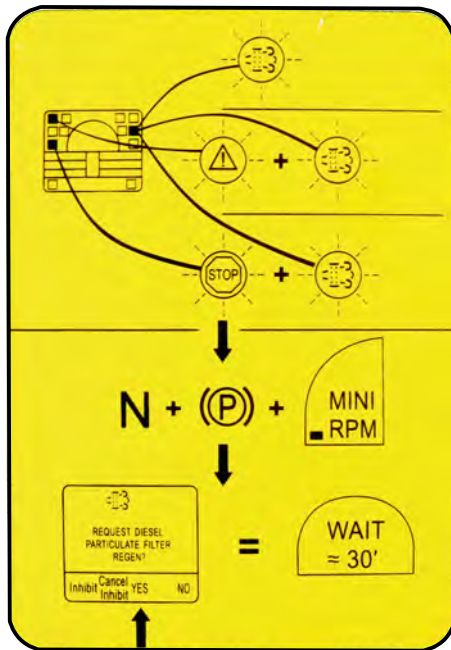





Figure 33: Parked DPF regeneration decal

The fuel is at sufficient level

1. Put the gear selector in neutral position
2. Apply the parking brake
3. Rest the forks on the ground
4. Put the engine in idling speed
5. Access to “DPF” regeneration menu on the control panel
6. Press on “**Request diesel particulate filter regen**” then on “**Yes**” to launch the “DPF” regeneration

 *Stay close to the machine during the exhaust regeneration*

 *The duration of the regeneration procedure is approximately 30 minutes*

 *When finished, the remaining hours before next regeneration will appear on the screen*

3.3. PARKING AND STORING THE MACHINE

3.3.1 PARKING THE MACHINE

1. Move the machine to an approved parking location.
2. Set the wheels straight.

 *Block the wheels if the parking location is on a slope.*

3. Put the gear selector to neutral.

4. Set the parking brake on.
5. Lower the forks to the ground.
6. Turn off the engine and remove the key.

3.3.2 STORING THE MACHINE FOR A SHORT DURATION

1. Wait for the machine to cool down.
2. Check the general state of the machine.

 *Report any damage to the machine.*

3. Check the lubricants levels. Top-up the lubricants levels if necessary.

3.4. TRANSPORT AND LIFTING OF THE MACHINE

3.4.1 LOADING/UNLOADING THE MACHINE

WARNING

Ensure that the safety instructions connected to the platform are respected before the loading of the machine and that the driver of the means of transport is informed about the dimensions and the weight of the machine.

WARNING

Ensure that the platform is of sufficient size and load capacity for transporting the machine. Check also the allowable ground contact pressure of the platform relative to the machine.

- Loading the machine
 1. Block the wheels of the platform.
 2. Attach the loading ramps to the platform in such a way as to give the shallowest possible ramp angle for the machine.
 3. Load the machine parallel to the platform.
 4. Stop the machine.
- Unloading the machine
 1. Block the wheels of the platform.
 2. Attach the loading ramps to the platform in such a way as to give the shallowest possible ramp angle for the machine.
 3. Power up the machine.

4. Unload the machine parallel to the platform.

3.4.2 TYING DOWN THE MACHINE

⚠ WARNING

Risk of machine falling during transport

Stow the machine onto the semi-trailer with sufficiently strong ropes.

1. Fix the chocks to the platform at the front and at the back of each tyre.

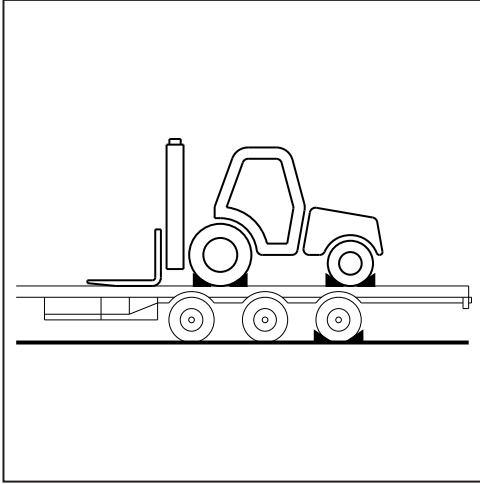

2. Also fix the chocks to the platform on the inside of each tyre.

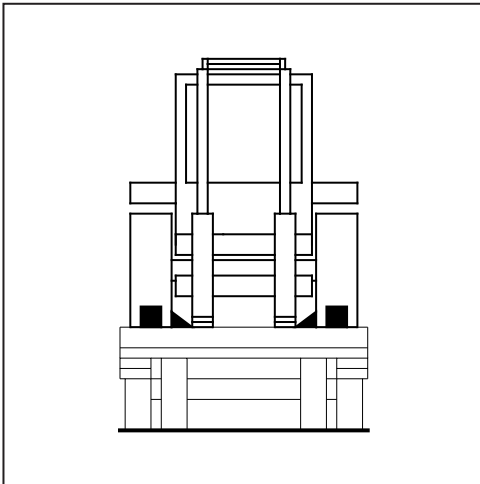

3. Stow the machine onto the semi-trailer with sufficiently strong ropes to the front by passing

above the articulation fittings (1) of the mast and to the back onto the towing pin (2).

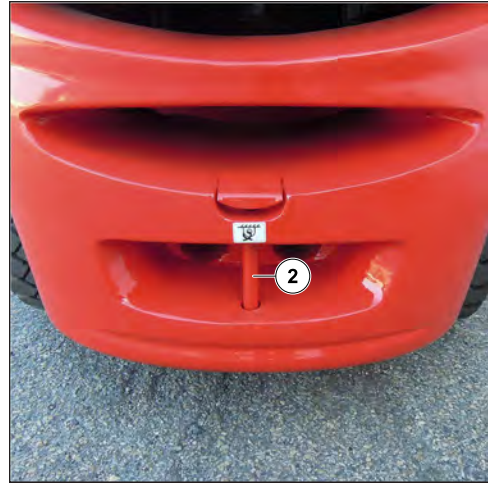
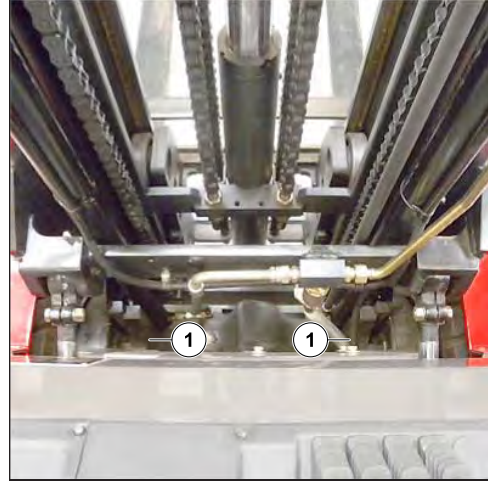

4. Tighten the ropes.

4. MAINTENANCE

4.1. MAINTENANCE COMPONENTS LOCATION - MI 50L→70 D D ST5 S1



Figure 34: Maintenance components location - MI 50L→70 D D ST5 S1

Table 68. Maintenance components location - MI 50L→70 D D ST5 S1

Marker	Description
1	Floor mat and floor engine cover
2	Engine cover key and button
3	Engine cover

Marker	Description
4	Fuel tank cap
5	Mast slinging points
6	Rear slinging points
7	Counterweight
8	Radiator core
9	Windscreen washer fluid tank
10	Cyclonic air pre-filter
11	Air conditioning unit

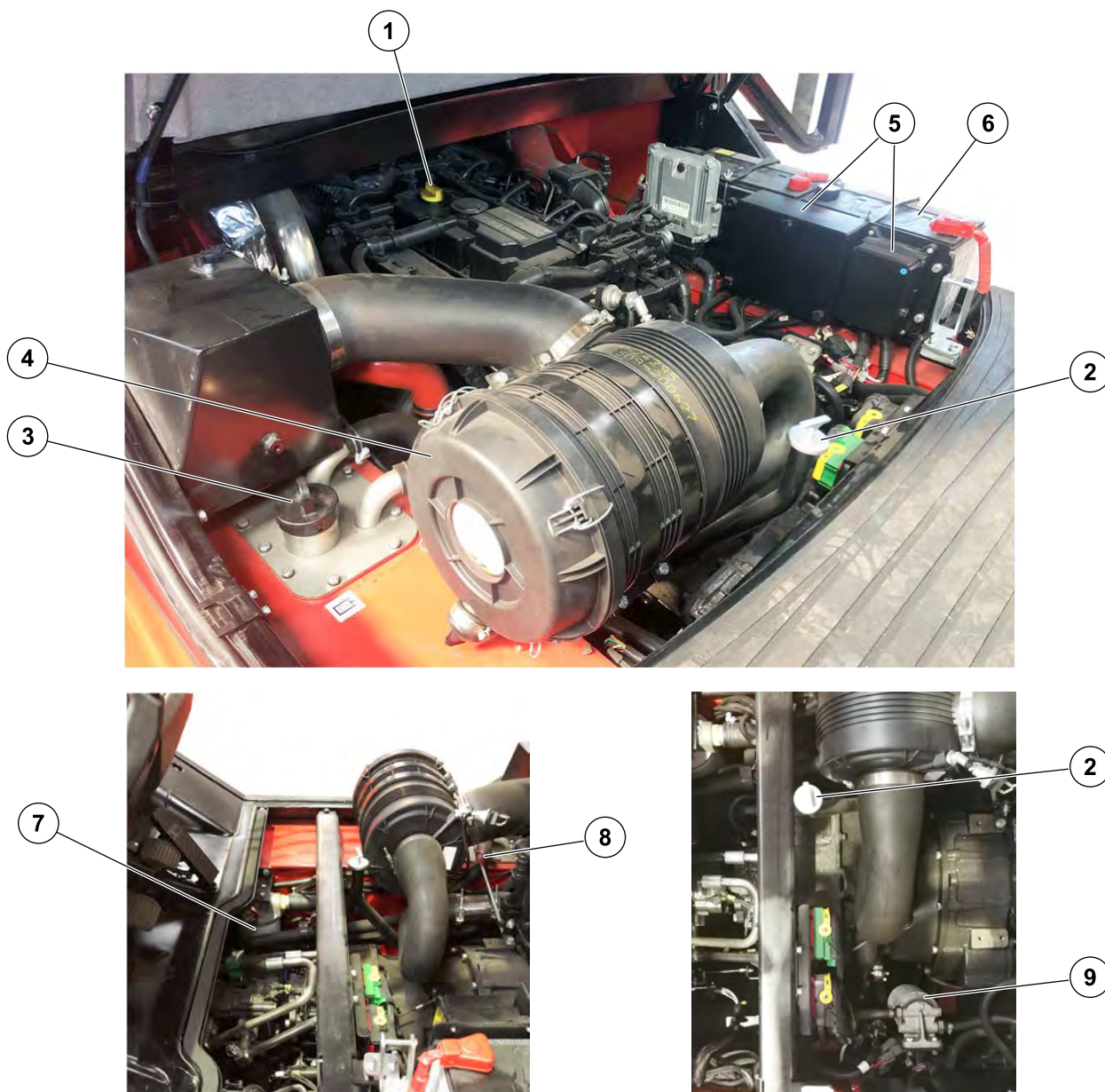

Figure 35: Maintenance components location under the engine cover - MI 50L→70 D D ST5 S1

Table 69. Maintenance components location under the engine cover - MI 50L→70 D D ST5 S1

Marker	Description
1	Engine oil filler cap
2	Transmission oil filler plug
3	Hydraulic fluid tank filler cap
4	Dry air filter
5	Fuse and relay box
6	Battery
7	Hydraulic return oil filter
8	Engine oil gauge
9	Fuel pre-filter

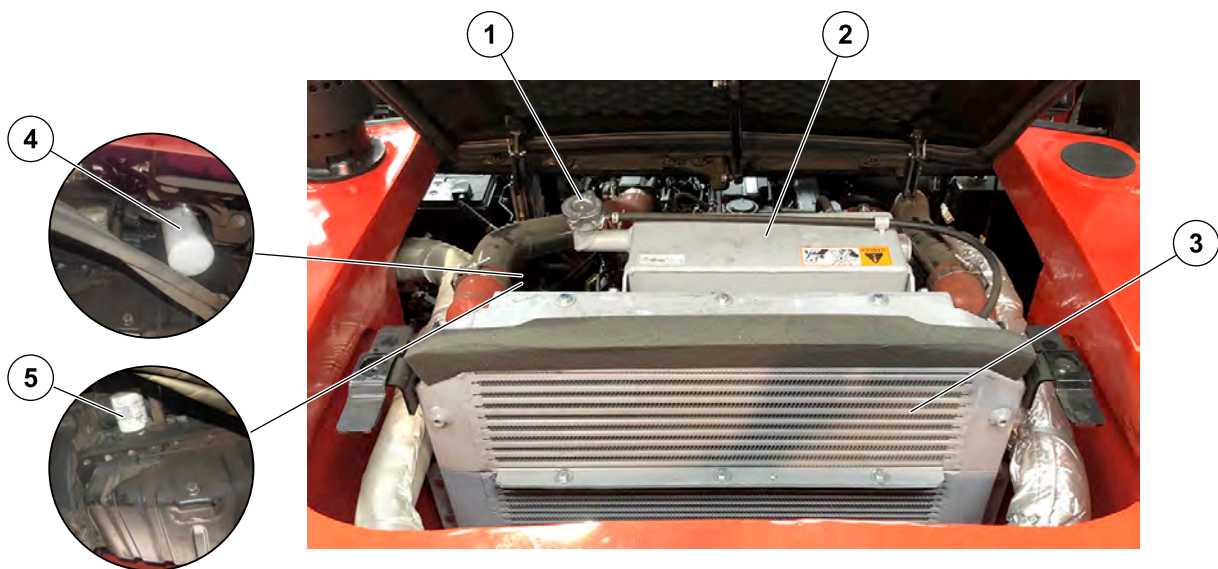

Figure 36: Maintenance components location under the rear cover - MI 50L→70 D D ST5 S1

Table 70. Maintenance components location under the rear cover - MI 50L→70 D D ST5 S1

Marker	Description
1	Coolant tank filler cap
2	Coolant tank
3	Radiator core
4	Fuel filter
5	Engine oil filter

4.2. MAINTENANCE COMPONENTS LOCATION - MI 80→100 D D ST5 S1



Figure 37: Maintenance components location - MI 80→100 D D ST5 S1

Table 71. Maintenance components location - MI 80→100 D D ST5 S1

Marker	Description
1	Floor mat and floor engine cover
2	Engine cover key and button
3	Engine cover
4	Fuel tank cap
5	Mast slinging points
6	Rear slinging points

Marker	Description
7	Counterweight
8	Radiator core
9	Windscreen washer fluid tank
10	Cyclonic air pre-filter
11	Diesel Exhaust Fluid "DEF" tank
12	Air conditioning unit

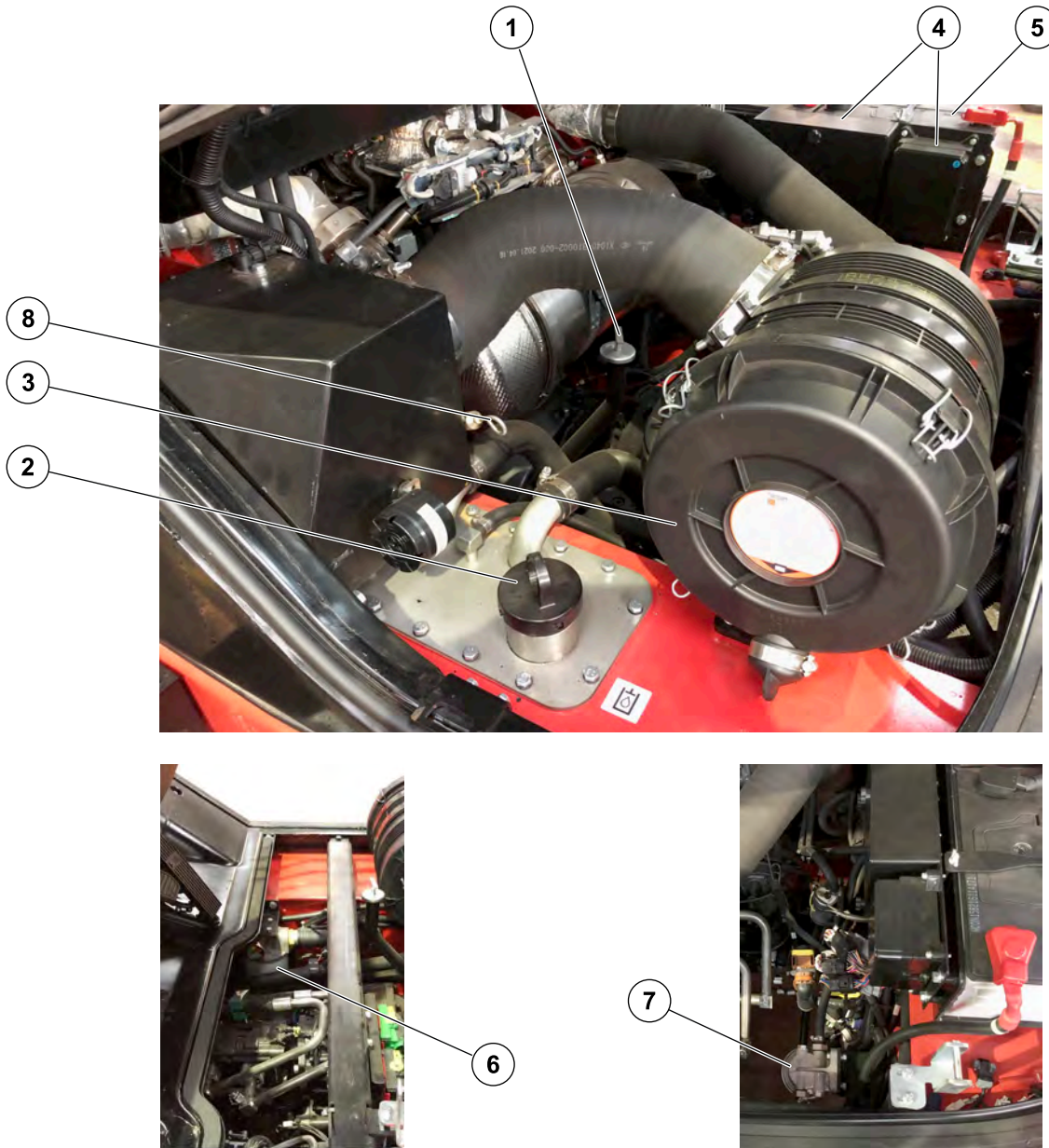

Figure 38: Maintenance components location under the engine cover - MI 80→100 D D ST5 S1

Table 72. Maintenance components location under the engine cover - MI 80→100 D D ST5 S1

Marker	Description
1	Transmission oil filler plug
2	Hydraulic fluid tank filler cap

Marker	Description
3	Dry air filter
4	Fuse and relay box
5	Battery
6	Hydraulic return oil filter
7	Fuel pre-filter

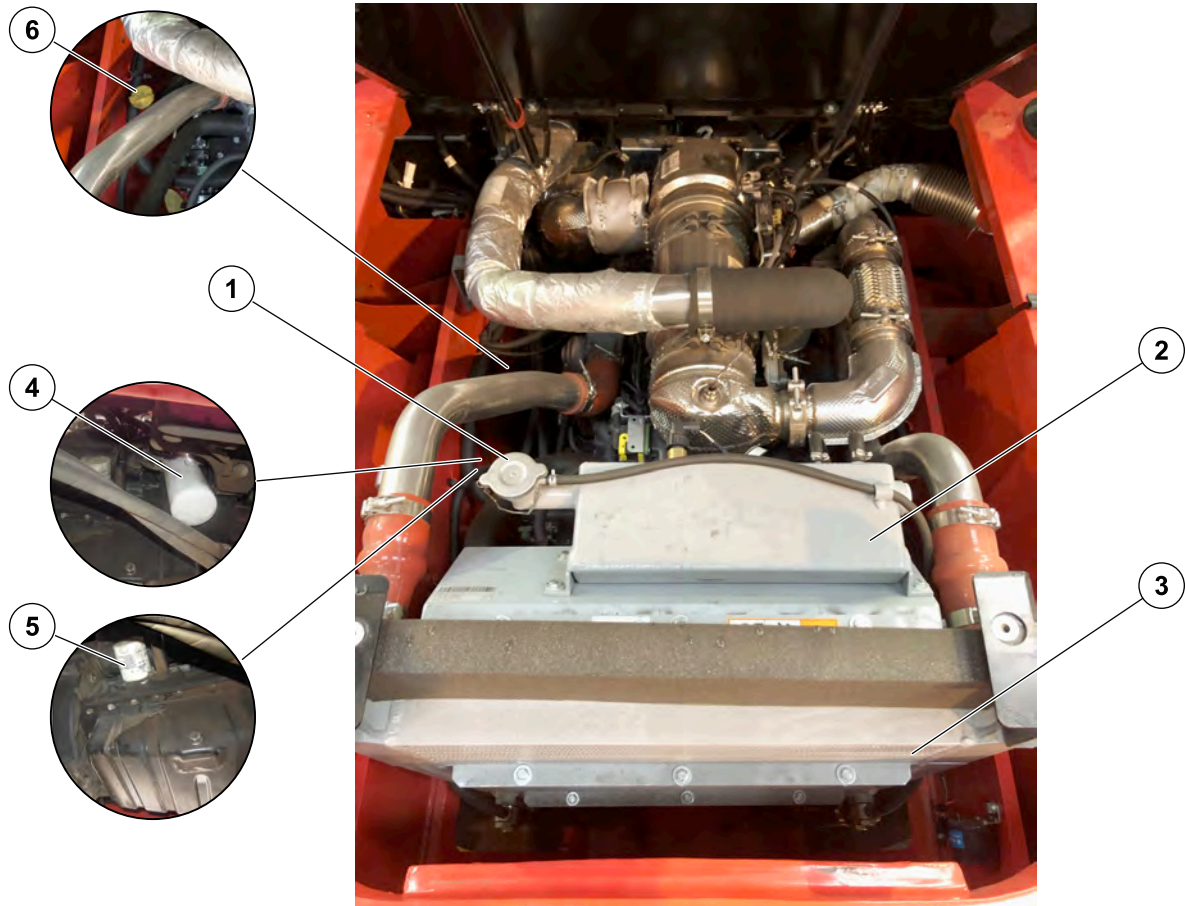

Figure 39: Maintenance components location under the rear cover - MI 80→100 D D ST5 S1

Table 73. Maintenance components location under the rear cover - MI 80→100 D D ST5 S1

Marker	Description
1	Coolant tank filler cap
2	Coolant tank
3	Radiator core
4	Fuel filter
5	Engine oil filter
6	Engine oil filler cap

4.3. OPENING THE ENGINE COVER

On the cab version, open the side doors, the side half-doors and the rear sliding window before lifting the engine cover.



Figure 40: Cab version engine cover opening

If the machine is equipped with mini-levers, retract the armrest.

- Lifting the engine cover
 1. Turn the key (1) counterclockwise.



Figure 41: Key in engine cover lock

2. Push the button on the lock.

3. Keep the button pushed in and gently lift the engine cover until the gas strut safety catch (2) locks in place.



Figure 42: Gas strut safety catch

- Lowering the engine cover
 1. Release the safety catch (2) and gently lower the engine cover.
 2. Check that the engine cover is properly closed.

4.4. OPENING THE REAR COVER - MI 50L → 70 D D ST5 S1

- Unscrew the two thumbscrews (1) and remove the housing (2).



The cover (3) will automatically open once cover (2) is removed.

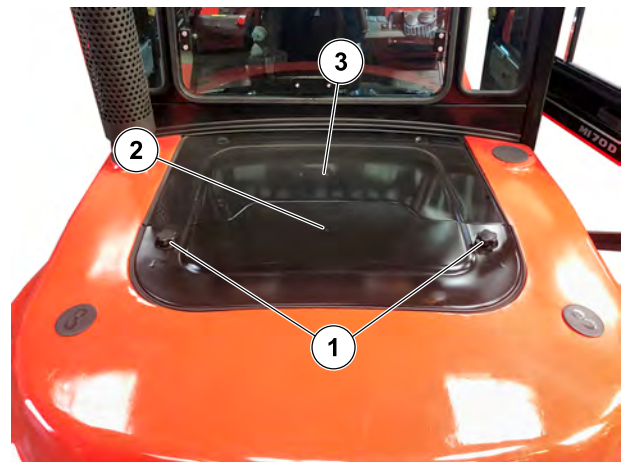

Figure 43: Rear cover opening

4.5. OPENING THE REAR COVER - MI 80→100 D D ST5 S1

1. Unscrew the two thumbscrews (1).

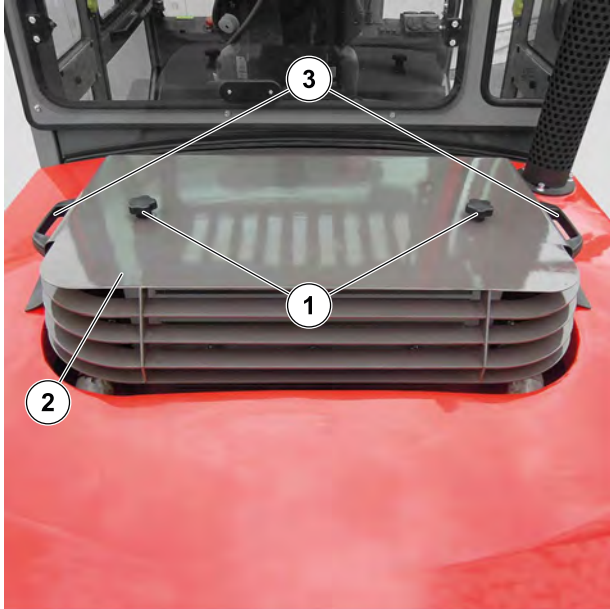

Figure 44: Rear cover opening

2. Gently lift the cover (2) using both handles (3) until the gas strut safety catch (4) locks in place.

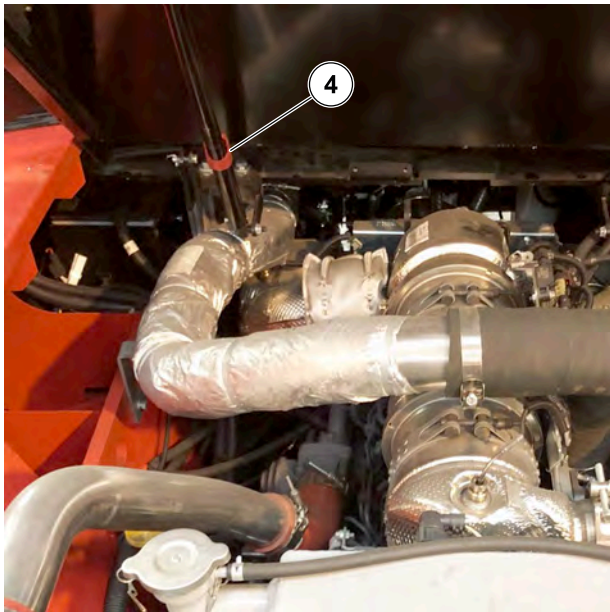

Figure 45: Gas strut safety catch

4.6. ORIGINAL MANITOU SPARE PARTS AND EQUIPMENT

4.6.1 ORIGINAL MANITOU SPARE PARTS AND EQUIPMENT

Our lift trucks must be serviced using original Manitou parts.

4.6.2 BY ALLOWING THE USE OF NON-ORIGINAL MANITOU PARTS, YOU RISK



The use of counterfeit parts or components not approved by the Manufacturer, means you lose the benefit of the contractual guarantee

- Legally - to be held responsible in the event of an accident.
- Technically - to cause operating malfunctions or shorten the life of the lift truck.

4.6.3 BY USING ORIGINAL MANITOU PARTS, YOU BENEFIT FROM

Through its network, MANITOU provides the user with the following,

- Know-how and competence.
- The guarantee of high-quality work.
- Original replacement parts.
- Help with preventive maintenance.
- Efficient help with diagnosis.
- Improvements due to experience feedback.
- Operator training.
- Only the MANITOU network has detailed knowledge of the design of the lift truck and therefore the best technical ability to provide maintenance.



Original replacement parts are distributed exclusively by Manitou and its dealer network. The dealer network list is available on the Manitou web site: www.manitou.com

4.7. MACHINE MAINTENANCE

4.7.1 DAILY AND WEEKLY MAINTENANCE



The operator is authorized to carry out this maintenance

These maintenance operations enables the operator to maintain the machine in a clean and safe condition.

4.7.2 MANDATORY FIRST 500 HOURS OR 6 MONTHS OF SERVICE



This service must be carried out after the first 500 hours of service or within the 6 months following putting the machine into service (whichever occurs first).

4.7.3 PERIODIC MAINTENANCE



The periodic maintenance must be carried out by a professional approved by the Manitou network.

Maintenance Schedule

This schedule enables the operator to keep up with the periodic maintenance of the machine by notifying the total number of hours of operation and the date of the service performed by the professional approved by the MANITOU network.

4.7.4 OCCASIONAL MAINTENANCE AND OPERATION

These maintenance tasks and operations are to be performed as required for the safety and upkeep of the machine.

4.8. MAINTENANCE SCHEDULE

- **1** List of maintenance procedures to be carried out every 500 hours.
- **2** List of maintenance procedures to be carried out every 1,000 hours of service or every 2 years.
- **3** List of maintenance procedures to be carried out every 2,000 hours of service or every 4 years.

SCHEDULE	10 hours or daily	50 hours or weekly	First 6 months	First 500 hours	500 hours or 1 year	1,000 hours or 2 years
PERIODIC MAINTENANCE	See: Daily maintenance or every 10 hours of service.	See: Weekly maintenance or every 50 hours of service.	Mandatory service	Mandatory service + 1	1	1+2
MACHINE COUNTER						
DATE OF SERVICING						
OBSERVATION						

SCHEDULE	1,500 hours or 3 years	2,000 hours or 4 years	2,500 hours or 5 years	3,000 hours or 6 years	3,500 hours or 7 years	4,000 hours or 8 years
PERIODIC MAINTENANCE	1	1+2+3	1	1+2	1	1+2+3
MACHINE COUNTER						

SCHEDULE	1,500 hours or 3 years	2,000 hours or 4 years	2,500 hours or 5 years	3,000 hours or 6 years	3,500 hours or 7 years	4,000 hours or 8 years
DATE OF SERVICING						
OBSERVATION						

SCHEDULE	4,500 hours or 9 years	5,000 hours or 10 years	5,500 hours or 11 years	6,000 hours or 12 years	6,500 hours or 13 years	7,000 hours or 14 years
PERIODIC MAINTENANCE	①	①+②	①	①+②+③	①	①+②
MACHINE COUNTER						
DATE OF SERVICING						
OBSERVATION						

4.9. SERVICING PROGRAM

4.9.1 DAILY AND WEEKLY MAINTENANCE

These maintenance operations enable the operator to maintain the lift truck in a clean and safe condition.



The operator is authorised to carry out this maintenance.

10 hours or daily maintenance

Table 74. 10 hours or daily maintenance

Operation	Description	Note
Check	Machine environment	
Check	Fuel level	
Check	Diesel Exhaust Fluid "DEF" level	Only for machines MI 80→100 D D ST5 S1
Check	Engine oil level	
Check	Coolant level	
Check	Fuel pre-filter	

50 hours or weekly maintenance

Carry out the daily maintenance procedures as well.

Table 75. 50 hours or weekly maintenance

Operation	Description	Note
Check	Tension of the alternator belt	
Check	Tension of the fan belt	
Check	Tension of the air conditioning compressor belt	
Check	Gear box seal	
Check	Front axle differential seal	
Check	Tire pressures	
Check	Wheel nut tightening torques	
Check	Hydraulic oil level	
Check	Windscreen washer fluid level	
Clean	Dry air filter cartridge	
Clean	Radiator core	
Clean	Air conditioning condenser core	

Operation	Description	Note
Grease	Articulations and guides	
Adjust	Tension and alignment of the mast lifting chains	

4.9.2 FIRST MANDATORY SERVICING

This service must be carried out at the first 500 hours of service or within 6 months of the initial start-up of the machine (whichever occurs first).

Mandatory servicing

Table 76. Mandatory servicing

Operation	Description	Note
Grease	Mast lifting chains	
Check	Speeds of hydraulic movements	Consult your dealer
Check	Condition of hoses and flexible pipes	Consult your dealer
Check	Condition of cylinders (leakage, rods)	Consult your dealer
Check	Fork wear	Consult your dealer
Check	Safety belt	
Check	Engine valve clearances	Consult your dealer
Check	Engine silent blocks	Consult your dealer
Check	Gear box silent blocks	Consult your dealer
Check	Condition of wheels and tyres	Consult your dealer
Check	Brakes	Consult your dealer
Check	Condition of wiring harnesses and cables	Consult your dealer
Check	Lights and signals	Consult your dealer
Check	Warning indicators	Consult your dealer
Check	Condition of the rear view mirrors	Consult your dealer
Check	Cab structure	Consult your dealer
Check	Frame structure	Consult your dealer
Check	Condition of attachments	Consult your dealer
Check	Wheel nut tightening torques	Consult your dealer
Check	Radiator	Consult your dealer

4.9.3 PERIODIC MAINTENANCE

The periodic maintenance must be carried out by a professional approved by the Manitou network.

500 hours or 1 year

Carry out the daily and weekly maintenance.

Table 77. 500 hours or 1 year

Operation	Description	Note
Grease	Mast lifting chains	
Replace	Engine oil	
Replace	Engine oil filter	See: Replacing engine oil

Operation	Description	Note
Check	Speeds of hydraulic movements	Consult your dealer
Check	Condition of hoses and flexible pipes	Consult your dealer
Check	Condition of cylinders (leakage, rods)	Consult your dealer
Check	Fork wear	Consult your dealer

1000 hours or 2 years

Carry out the 500 hours service.

Table 78. 1000 hours or 2 years

Operation	Description	Note
Check	Seat belt	
Grease	Service brake pedal axle	
Replace	Fuel filter	
Replace	Fuel pre-filter	
Replace	Dry air filter cartridge	
Replace	Gearbox oil	
Replace	Gearbox oil filter	See: Replacing gearbox oil
Clean	Metal gearbox oil filter	See: Replacing gearbox oil
Replace	Hydraulic oil	
Replace	Hydraulic oil filter	See: Replacing hydraulic oil
Clean	Hydraulic oil tank filter cap	See: Replacing hydraulic oil
Clean	Hydraulic oil tank suction strainers	See: Replace hydraulic oil
Check	Engine speeds	Consult your dealer
Check	Engine valve clearances	Consult your dealer
Check	Engine silent blocks	Consult your dealer
Check	Gear box silent blocks	Consult your dealer
Check	Condition of wheels and tires	Consult your dealer
Check	Brakes	Consult your dealer
Check	Condition of wiring harnesses and cables	Consult your dealer
Check	Lights and signals	Consult your dealer
Check	Warning indicators	Consult your dealer
Check	Condition of the rear view mirrors	Consult your dealer
Check	Cab structure	Consult your dealer
Check	Frame structure	Consult your dealer
Check	Condition of attachments	Consult your dealer

2000 hours or 4 years

Carry out the 500 and 1000 hours service.

Table 79. 2000 hours or 4 years

Operation	Description	Note
Check	Wheel nut tightening torques	
Clean	Fuel tank	
Replace	Coolant	
Replace	Dry air filter safety cartridge	
Replace	Front axle differential oil	

Operation	Description	Note
Check	Radiator	Consult your dealer
Check	Water pump and thermostat	Consult your dealer
Check	Alternator and starter	Consult your dealer
Check	Alternator belt	Consult your dealer
Check	Turbocharger	Consult your dealer
Check	Injection pump	Consult your dealer
Check	Injectors	Consult your dealer
Check	Swivel pins	Consult your dealer
Check	Steering connecting rods	Consult your dealer
Check	Rear axle oscillation	Consult your dealer
Check	Steering	Consult your dealer
Check	Rear axle	Consult your dealer
Check	Brakes wear	Consult your dealer
Check	Mast lifting chains	Consult your dealer
Check	Condition of boom assembly	Consult your dealer
Check	Mast lifting chain pulleys	Consult your dealer
Check	Mast guide rollers	Consult your dealer
Check	Mast bearing rollers	Consult your dealer
Check	Thickness of the mast wearing plates	Consult your dealer
Check	Attachment carriage	Consult your dealer
Check	Hydraulic circuit flow rates	Consult your dealer
Check	Bearings and bushings	Consult your dealer
Clean	Hydraulic oil tank and strainer	Consult your dealer
Clean	Air-conditioning (option)	Consult your dealer

4.10. 10 HOURS OF SERVICE OR DAILY MAINTENANCE

4.10.1 CHECK LIFT TRUCK ENVIRONMENT



Follow the operator instructions.



Particular attention should be paid to accumulations of flammable materials and fuel or lubricant leaks. These significantly increase the risk of fire outbreaks.

1. Carry out a general inspection of the lift truck:
 - 1.1. Fluid leaks or stains on the ground.
 - 1.2. Additional objects on the lift truck and in the driver protection or the cab.

- 1.3. Mounting and adjustment of lights and rear view mirrors.
- 1.4. Mounting and locking of the attachment.
- 1.5. Condition of the tyres, to detect cuts, blisters, wear, etc.
2. According to the conditions of use and the environment, ensure that the lift truck is clean.
 - 2.1. Cleanliness of lights, rear view mirrors, windows and the driver's cab.
 - 2.2. Cleanliness of the engine housing and inside the frame to prevent leaks and build-up of materials (e.g. straw, flour, sawdust, organic waste, etc.).

4.10.2 CHECK THE FUEL LEVEL



Risk of explosion

Never smoke or approach the machine with a flame during filling operations or when the fuel tank is open.

Never refill the fuel tank while the engine is running.

NOTICE

Risk of engine and fuel system damage

Keep the fuel tank well filled to minimise condensation due to atmospheric conditions.

Checking the fuel level

- Visually check the fuel level on the work page



If the level is low, fill up the fuel tank

Filling the fuel tank

- Remove the fuel tank cap.
- Fill the tank with clean, filtered diesel.
- Put back the fuel tank cap.
- Visually check that there is no leakage in the tank and pipes.

◀ 2.7.4 PV380 work page, page 55

◀ 5.1.1 Lubricants & fuel - MI 50L→100 D D ST5 S1, page 108

4.10.3 CHECK THE DIESEL EXHAUST FLUID "DEF" LEVEL

⚠ WARNING

Risk of burn hazard

Wear personal protective equipment (gloves and goggles)

NOTICE

Risk of engine and exhaust system damage

Make sure the "DEF" tank is never empty or at low level.

Checking the "DEF" level

- Visually check the "DEF" level on the work page



If the level is low, fill up the "DEF" tank

Filling the "DEF" tank

- Remove the "DEF" tank cap.
- Fill the tank to the bottom of the filler neck with clean, filtered "DEF".
- Put back the "DEF" tank cap.

- Visually check that there is no leakage in the tank and pipes.

◀ 2.7.4 PV380 work page, page 55

◀ 5.1.1 Lubricants & fuel - MI 50L→100 D D ST5 S1, page 108

4.10.4 CHECK THE ENGINE OIL LEVEL

Put the machine on level ground with the engine stopped, and let the oil settle in the sump.

- Open the engine cover.
- Pull out and clean the dipstick (1).

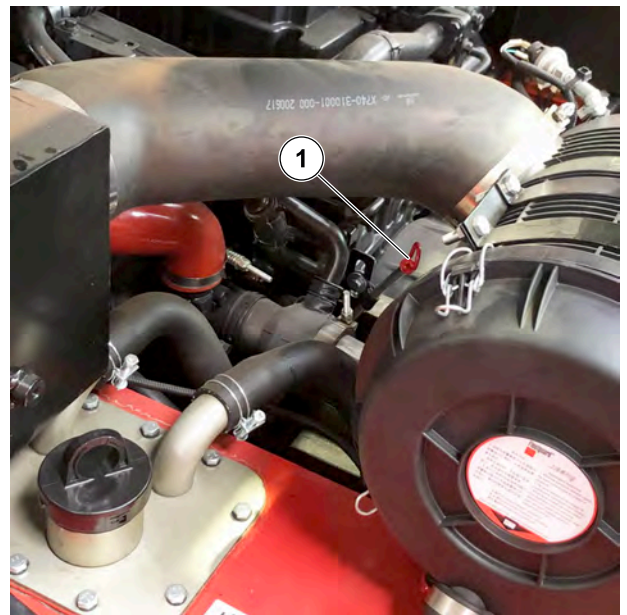

Figure 46: Dipstick - MI 50 L→70 D D ST5 S1



Figure 47: Dipstick - MI 80→100 D D ST5 S1

3. Re-insert the dipstick and remove it again.
4. Check the correct level between the two notches.
5. If necessary, add oil.
6. Remove the engine cover.
7. Open the rear cover.
8. Remove the filler plug (5).

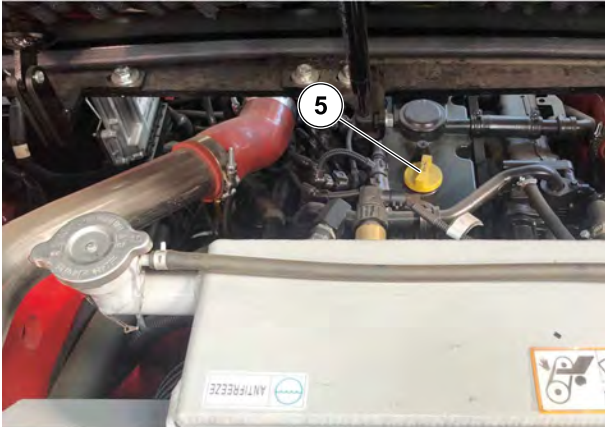

Figure 48: Filler plug - MI 50 L→70 D D ST5 S1



Figure 49: Filler plug - MI 80→100 D D ST5 S1

9. Visually check that there is no leakage or seepage of oil in the engine.
- << 4.3. *Opening the engine cover*, page 76
 - << 4.4. *Opening the rear cover - MI 50L→70 D D ST5 S1*, page 77
 - << 4.5. *Opening the rear cover - MI 80→100 D D ST5 S1*, page 78

4.10.5 CHECK THE COOLANT LEVEL

⚠ WARNING

To avoid any risk of spraying or burning, wait until the engine has cooled down before removing the cooling circuit filler plug.

If the coolant is very hot, add only hot coolant (80 °C).

In an emergency, you can use water as a coolant, then change the cooling circuit liquid as soon as possible.

Place the machine on level ground with the engine stopped, and allow the engine to cool.

1. Open rear cover.
2. Check the correct level in the middle of the gauge (3).
3. If necessary, add coolant.
 - 3.1. Slowly turn the radiator cap (1) up to the safety stop.



Figure 50: Radiator cap & filler port

- 3.2. Allow the pressure and the steam to escape.
 - 3.3. Press down and turn the cap so as to release it.
 - 3.4. Add coolant via filler port (2) up to the middle of gauge (3).
 - 3.5. Lubricate slightly the filler neck in order to facilitate the setting and the removal of the radiator cap.
 - 3.6. Do a visual check to make sure that there is no leakage in the radiator and pipes.
- << 4.4. *Opening the rear cover - MI 50L→70 D D ST5 S1*, page 77
 - << 4.5. *Opening the rear cover - MI 80→100 D D ST5 S1*, page 78

4.10.6 CHECK THE FUEL PRE-FILTER

1. Switch off the machine's ignition.
2. Open the engine cover.
3. Carefully clean the outside of the filter and its holder to prevent dust from getting into the system.
4. Disconnect electrical wiring harness (1) from the fuel pre-filter.

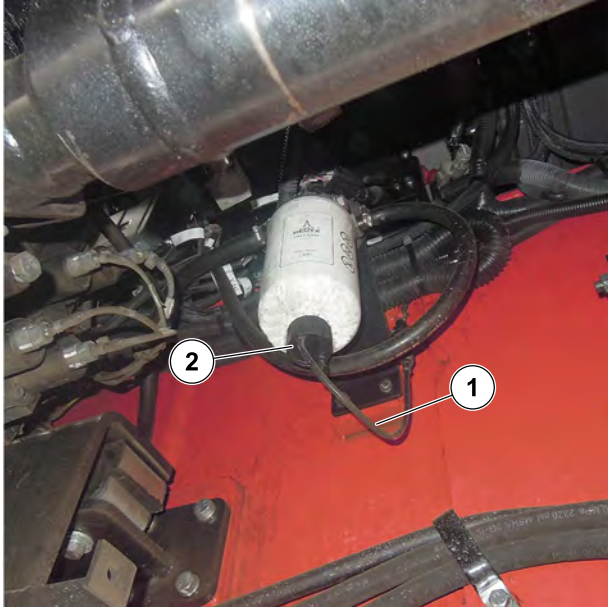

Figure 51: Electrical wiring harness & drain plug

5. Place a container under the drain plug (2).
6. Unscrew the drain plug (2) by two turns.
7. Let the diesel fuel flow out until it is free from impurities and water.
8. Re-tighten drain plug (2) and reconnect the wiring harness (1).
9. Turn on the ignition to power the boost pump and release air from the pre-filter.

◀ 4.3. *Opening the engine cover*, page 76

4.11. 50 HOURS OF SERVICE OR WEEKLY MAINTENANCE

4.11.1 CHECK THE TENSION OF THE ALTERNATOR BELT

NOTICE

If the belt has to be changed, do a check of the tension again after the first 20 hours of operation

The rear cover is open.

1. Do a check of the belt (1) tension between pulleys under normal pressure applied by the thumb (98 N/ 10 kg).

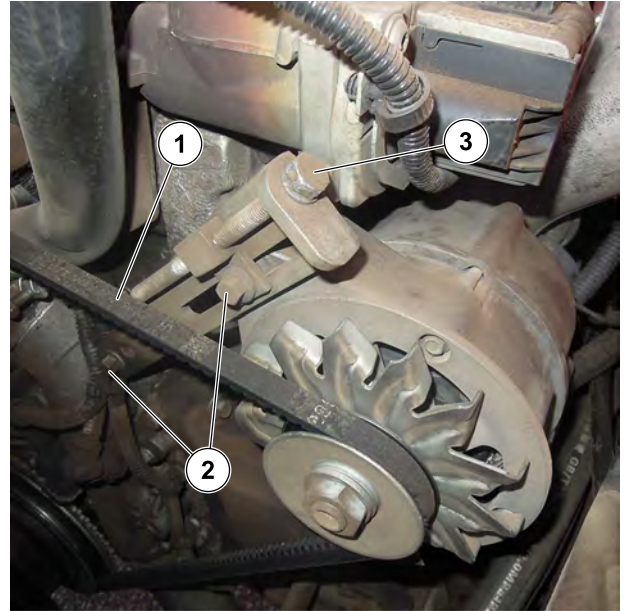
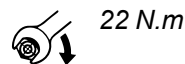

Figure 52: Alternator belt

Belt movement must be between 7 and 10 mm.

2. Adjust if necessary.
3. Loosen screws (2) by two to three turns.
4. Tighten or loosen screw (3) to obtain the required belt tension.
5. Retighten screws (2) :



◀ 4.4. *Opening the rear cover - MI 50L→70 D D ST5 S1*, page 77

◀ 4.5. *Opening the rear cover - MI 80→100 D D ST5 S1*, page 78

4.11.2 CHECK THE TENSION OF THE FAN BELT

NOTICE

If the belt has to be changed, do a check of the tension again after the first 20 hours of operation

The rear cover is open.

1. Do a check of the belt (1) tension between pulleys under normal pressure applied by the thumb (98 N/ 10 kg).

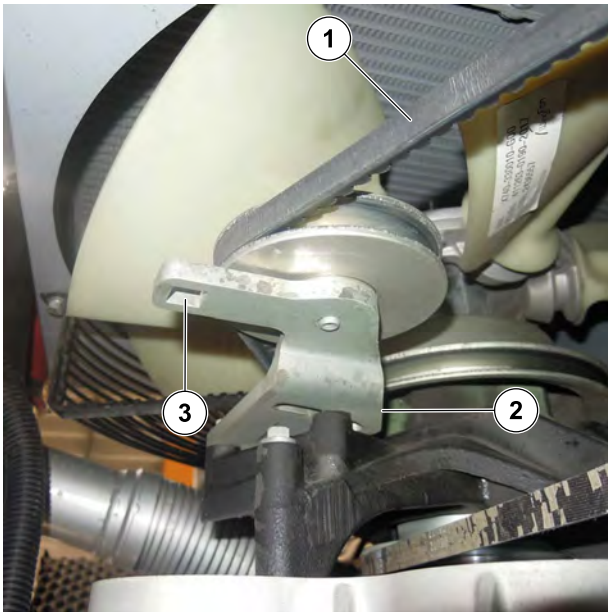
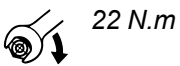

Figure 53: Fan belt

Belt movement must be between 7 and 10 mm.

2. Adjust if necessary.
3. Loosen screw (2) by two to three turns.
4. Use a wrench to swivel the tensioner pulley (3) and obtain the required belt tension.
5. Retighten screw (2) :



- < 4.4. Opening the rear cover - MI 50L→70 D D ST5 S1, page 77
- < 4.5. Opening the rear cover - MI 80→100 D D ST5 S1, page 78

4.11.3 CHECK THE TENSION OF THE AIR CONDITIONING COMPRESSOR BELT

NOTICE

If the belt has to be changed, do a check of the tension again after the first 20 hours of operation

The rear cover is open.

1. Do a check of the belt tension between pulleys under normal pressure applied by the thumb (98 N/ 10 kg).

Belt movement must be between 7 and 10 mm.

2. Adjust if necessary.
3. Loosen screws by two to three turns.
4. Tighten or loosen screw to obtain the required belt tension.
5. Retighten screws :

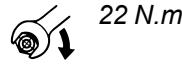

- < 4.4. Opening the rear cover - MI 50L→70 D D ST5 S1, page 77
- < 4.5. Opening the rear cover - MI 80→100 D D ST5 S1, page 78

4.11.4 CHECK THE GEAR BOX SEAL

The machine is on level ground with the engine stopped.

1. Open the engine cover.
2. Remove the floor mat.
3. Remove the metal plate on the floor.
4. Do a visual check for seepage and leaks.
5. If there are any, check the level.
6. Pull out and clean the dipstick (1).

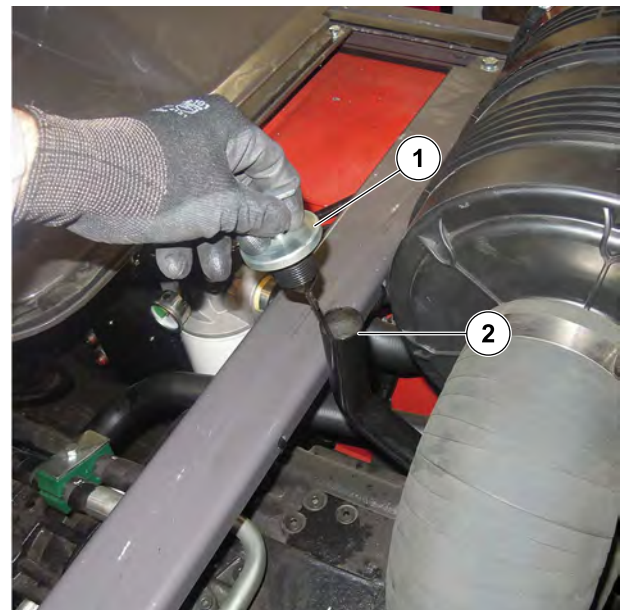

Figure 54: Dipstick & filler hole

7. Reinsert the dipstick and remove it again.
8. Check the correct level between the two notches.
9. If necessary, add oil through the filler hole (2).

- < 4.3. Opening the engine cover, page 76

4.11.5 CHECK THE FRONT AXLE DIFFERENTIAL SEAL

The machine is on level ground with the engine stopped.

1. Do a visual check for seepage and leaks.
2. If there are any, check the level.
3. Raise the mast to gain access to the plug.
4. Remove the level plug (1), the oil should be flush with the edge of the opening.

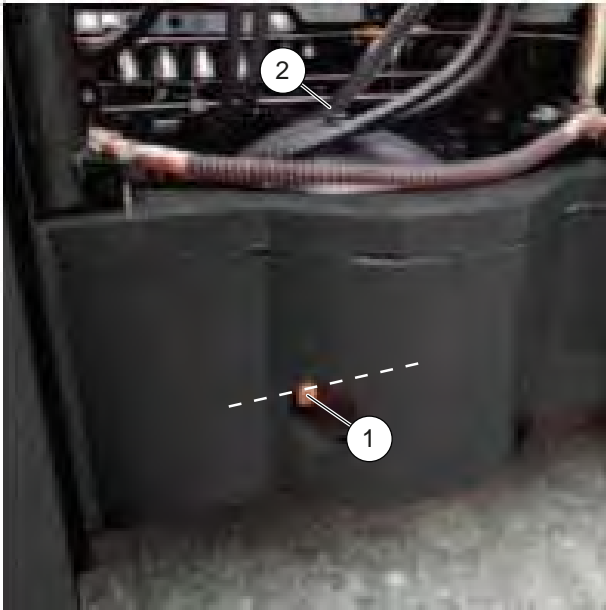
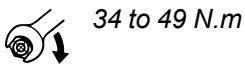

Figure 55: Level plug & filler port

5. If necessary, add oil through the filler port (2).
6. Refit and tighten the plugs :



34 to 49 N.m

4.11.6 CHECK THE TIRE PRESSURES

⚠ WARNING

Air pressure hazard

Use a calibrated pressure gage with an air pipe extension at least 3 meters long.

Keep all persons at a distance during inflation.

Check that the air hose is correctly connected to the tire valve before inflating.

Inflate to the recommended tire pressures.



There is an *OPTIONAL* anti-flat inflation.

1. Check tire pressures.
2. If necessary, restore tire pressure.

◀ 2.5.15 Ground contact pressure - MI 50L→100 D D ST5 S1, page 46

4.11.7 CHECK THE WHEEL NUT TIGHTENING

NOTICE

Deterioration hazard

Follow the instructions



There is an *OPTIONAL* wheel toolkit.

1. Check the presence and torque load of the wheel nuts
2. If necessary, tighten to torque

◀ 4.14.1 Check the wheel nut tightening torques, page 102

4.11.8 CHECK THE HYDRAULIC OIL LEVEL

NOTICE

Risk of malfunctioning of hydraulic controls

Use a very clean funnel and clean the top of the oil can before filling.

Always maintain the oil level at a maximum as cooling depends on the oil flowing through the tank.

The machine is on level ground.

The engine is stopped.

1. Open the engine cover.

2. Remove cap (1).

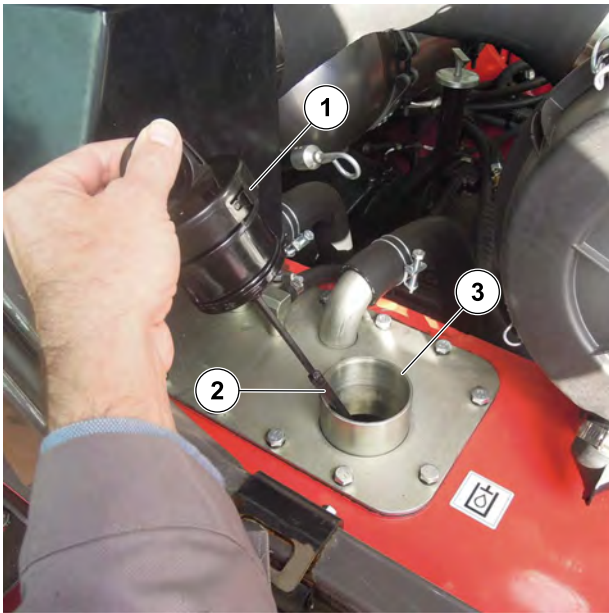
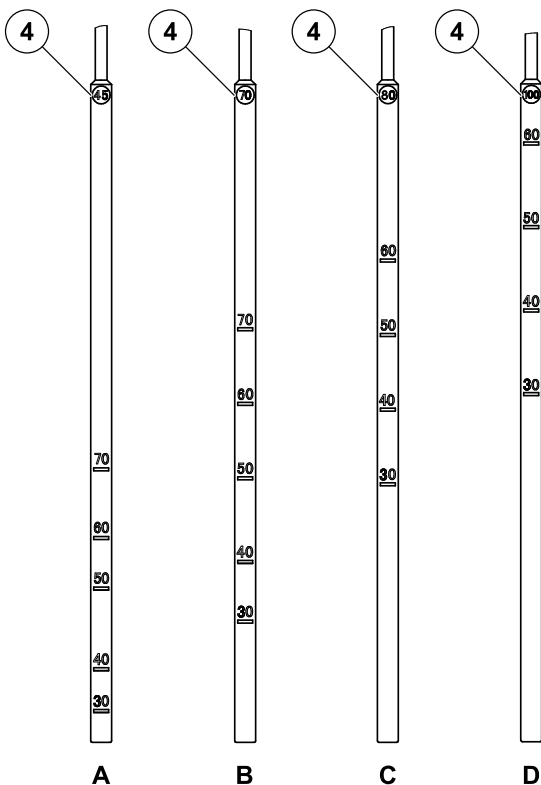

Figure 56: Hydraulic oil cap, dipstick and filler hole

3. Identify the (2) dipstick according to the (4) marking.



Dipstick	Machine	Marking (4)
A	MI 50L D D ST5 S1	45
B	MI 60 D D ST5 S1	70
B	MI 70 D D ST5 S1	70

Dipstick	Machine	Marking (4)
C	MI 80 D D ST5 S1	80
D	MI 100 D D ST5 S1	100

4. Do a visually check of the hydraulic oil level on the (2) dipstick according to the table below :

Table 80. Hydraulic oil level according to mast lifting height

Mast lifting height (mm)	Hydraulic oil level			
	Dipstick A	Dipstick B	Dipstick C	Dipstick D
≤ 3000	70	30		
> 3000 ≤ 4000	70	40		
> 4000 ≤ 5000	70	50		
> 5000 ≤ 6000	74	60		
> 6000 ≤ 7000	74	70		



For machines fitted with a hydraulic attachment (side shift carriage, positioner, etc.) add the equivalent of 25 mm of oil on the dipstick.

5. If necessary, add oil through the filler hole (3).
6. Refit cap (1).
7. Do a visually check to make sure that there is no leakage in the tank and pipes.
8. Do a check of the operation of the hydraulic controls.

Consult your dealer in case of abnormal operation of hydraulic controls

◀ 4.3. Opening the engine cover, page 76

◀ 5.1.1 Lubricants & fuel - MI 50L→100 D D ST5 S1, page 108

4.11.9 CHECK THE WINDSCREEN WASHER FLUID LEVEL

1. Lift up the windscreen washer tank access cover (1).

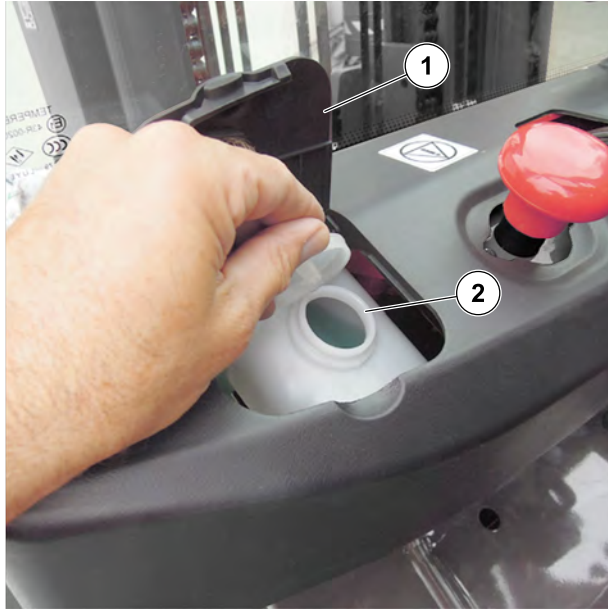

Figure 57: Access cover & filler port

2. Do a visually check of the level.
3. If necessary, add windscreen washer fluid through filler port (2).

4.11.10 CLEANING THE DRY AIR FILTER CARTRIDGE

⚠ DANGER

Dust hazard

Wear safety eyewear during this operation.

NOTICE

Deterioration hazard

If the clogging indicator light comes on, this operation must be carried out as quickly as possible (1 hour maximum).

Do not use the machine with a damaged cartridge or without an air filter.

Clean the cartridge more often when the machine is operating in a dusty environment.

Clean the cartridge in a clean place away from the air filter unit.

Never clean the cartridge by tapping it on a hard surface.

Never wash the dry air filter cartridge.

Never clean or repair the air filter safety cartridge. Replace it with a new one.



Pre-filtration cartridges are available for use in very dusty atmospheres (contact your dealer).

1. Open the engine cover.
2. Release the locks (1) and remove the cover (2).

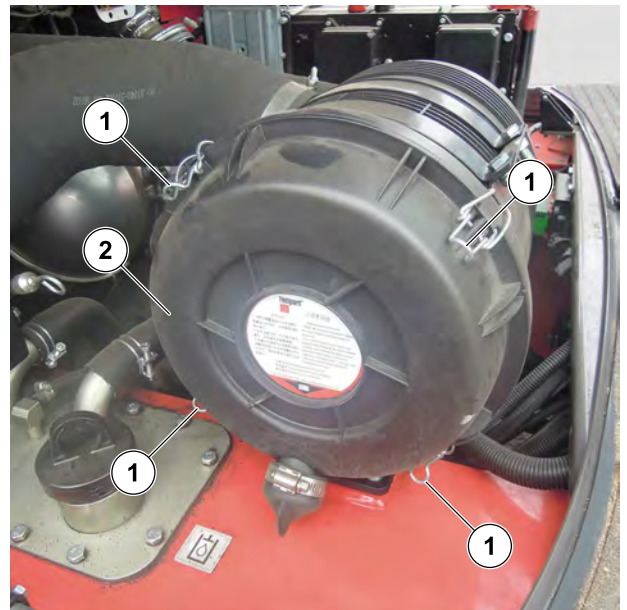

Figure 58: Locked cover

- Gently remove cartridge (3) taking care to avoid spilling the dust.



Figure 59: Cartridge

- Leave the safety cartridge in place.
 - Using a compressed air jet (max. 3 bar), clean the filter cartridge from the top to the bottom and from the inside toward the outside, maintaining a minimum safety distance of 30 mm to avoid damaging the cartridge. Cleaning is completed when there is no more dust escaping from the cartridge.
 - Clean the cartridge seal surfaces with a damp, clean lint-free cloth and grease with a silicone lubricant (MANITOU part no.: 479292).
 - Visually inspect the external condition of the air filter and its mounts.
 - Also check the condition and attachment of the hoses.
- ◀ 4.3. Opening the engine cover, page 76

4.11.11 CLEAN THE RADIATOR CORE

⚠ DANGER

Dust hazard

Wear safety eyewear during this operation.

NOTICE

Deterioration hazard

Clean the radiator core more often when the machine is operating in a polluting environment (e.g. dust, pollen, straw, flour, sawdust, etc.).

Do not use a water jet or high pressure steam.

- Open the rear cover
- Using a soft cloth, clean the radiator in order to remove as much dirt as possible.
- Clean the radiator with jet of compressed air directed from the inside toward the outside. This is the only effective way of removing impurities (opposite direction to the cooling air flow).

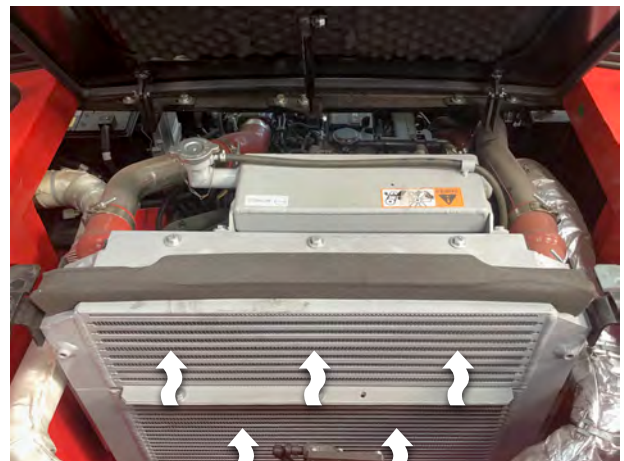

Figure 60: Direction of the compressed air flow through the radiator core

- ◀ 4.4. Opening the rear cover - MI 50L→70 D D ST5 S1, page 77
- ◀ 4.5. Opening the rear cover - MI 80→100 D D ST5 S1, page 78

4.11.12 CLEAN THE AIR CONDITIONING CONDENSER CORE

⚠ DANGER

Dust hazard

Wear safety eyewear during this operation.

NOTICE**Deterioration hazard**

Clean the air conditioning condenser core more often when the machine is operating in a polluting environment (e.g. dust, pollen, straw, flour, sawdust, etc.).

Do not use a water jet or high pressure steam.

1. Visually check whether the condenser is and clean it if necessary.
2. Clean the condenser using a compressed air jet aimed in the same direction as the air flow.



Figure 61: Direction of the compressed air flow through the air conditioning condenser core

3. Clean with the fans running for best results.

4.11.13 GREASE THE ARTICULATIONS AND GUIDES

⚠ DANGER**Crushing or pinching risk**

Switch off the lift truck's ignition.

NOTICE**Deterioration hazard**

In an extremely dusty or oxidizing atmosphere, reduce this interval to every 10 hours of service or every day.

In case of technical faults, consult your dealer.



To be carried out weekly, if the lift truck has been operated for less than 50 hours during the week.

For each grease fitting :

Table 81. List of grease fittings

Marker	Designation	Quantity
1	Articulation axles at the foot of the mast	2
2	Tilt cylinder head axles	2
3	Tilt cylinder foot axles	2
4	Fork carriage	according to model
5	Swivel pins	4
6	Steering connecting rods	2
7	Rear axle oscillation	2
8	Cab door articulation axles	8

1. Clean it.
2. Pump grease.
3. Remove the excess.

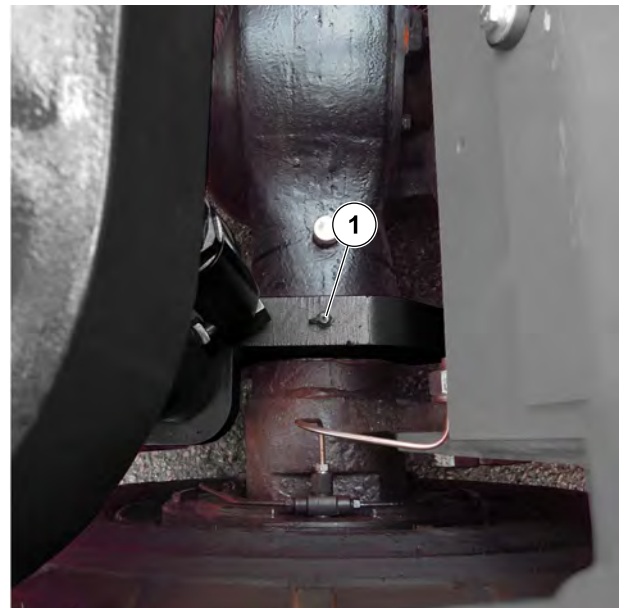

Figure 62: Articulation axles at the foot of the mast

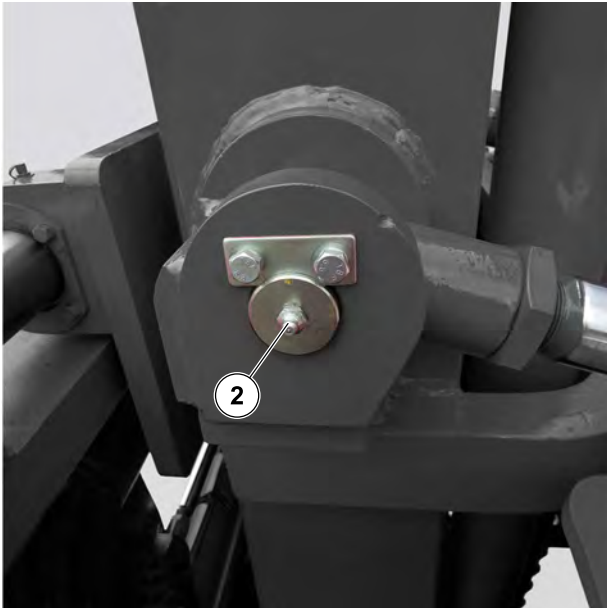

Figure 63: Tilt cylinder head axles

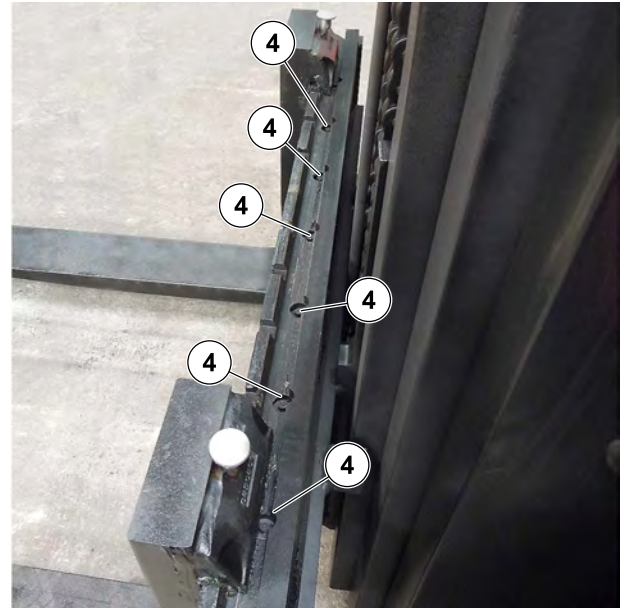

Figure 65: Fork carriage

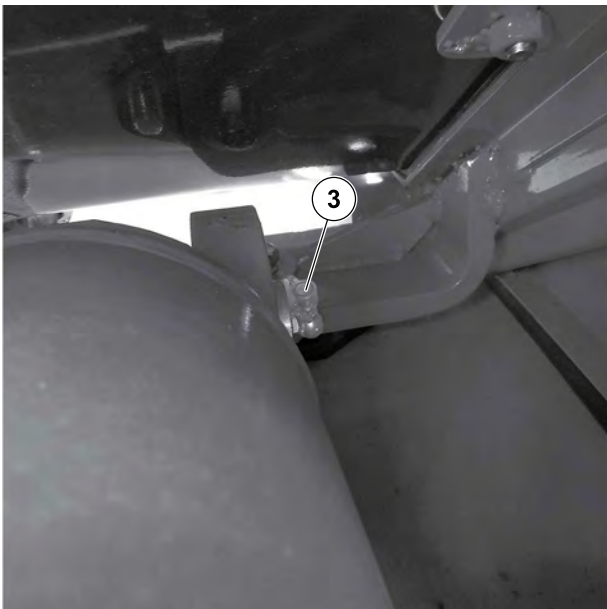

Figure 64: Tilt cylinder foot axles

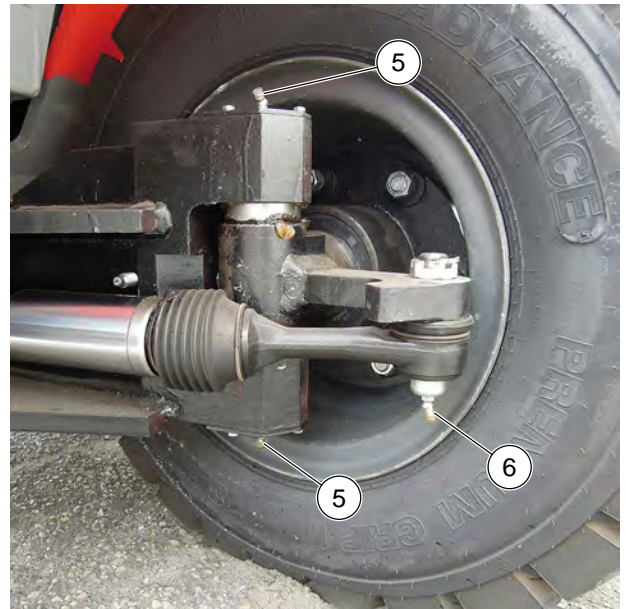

Figure 66: Swivel pins and steering connecting rods

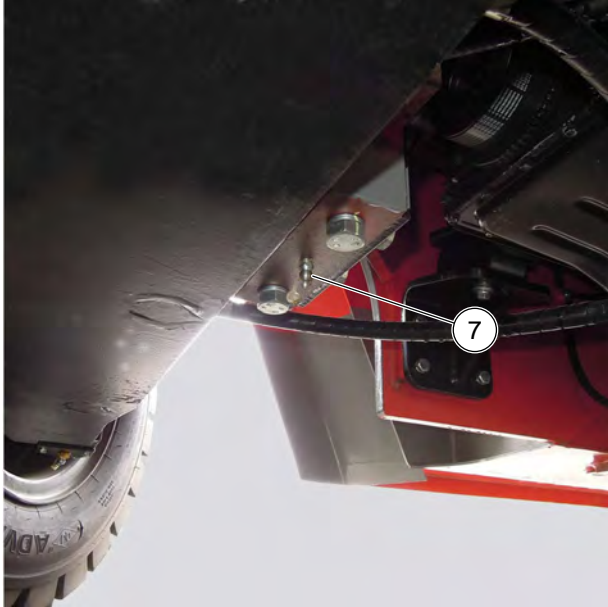

Figure 67: Rear axle oscillation



Figure 68: Cab door articulation axles

4.11.14 ADJUST THE TENSION & ALIGNMENT OF THE MAST LIFTING CHAINS

NOTICE

Deterioration hazard

These checks are important for good working operation of the mast. In case of technical faults, consult your dealer.

Put the lift truck on level ground with the mast in a vertical position and the forks lifted at approximately 200 mm.

1. Visually check the state of the mast and the forks.
2. Check the alignment of the mast lifting chains between the carriage chain fasteners and the chain rollers.
3. Manually verify the chain tension and, if necessary, adjust as indicated below while ensuring that the carriage is perpendicular to the mast.
4. Loosen nut (1).

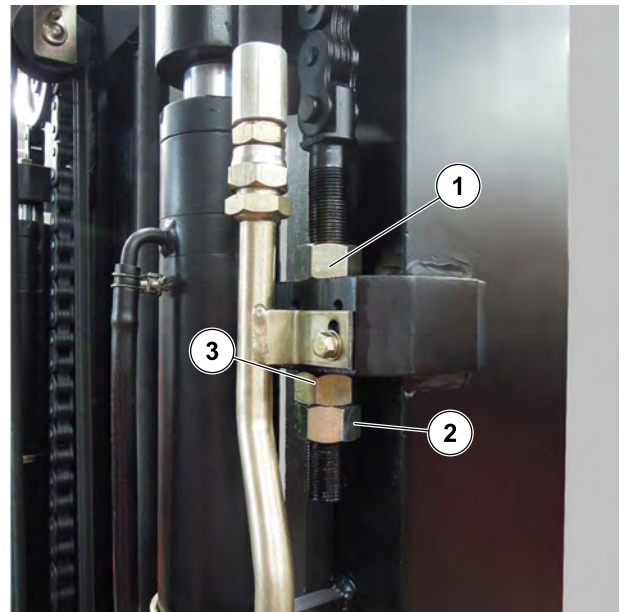

Figure 69: Nuts & the chain tensioner lock nut

5. Loosen the chain tensioner lock nut (2).
6. Adjust the tension by tightening or loosening the nut (3) while checking the alignment of the lifting chains.
7. Then tighten lock nut (2) and nut (3).
8. Retighten the nut (1).

4.12. 500 HOURS OF SERVICE OR 1 YEAR

4.12.1 GREASE THE MAST LIFTING CHAINS

⚠ WARNING

In case of technical faults, consult your dealer.

1. Wipe the mast lifting chains with a clean, lint-free cloth.

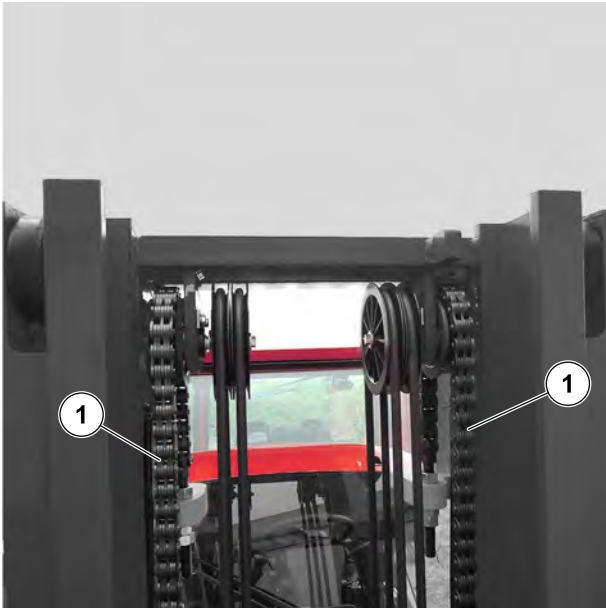

Figure 70: Greasing the mast lifting chains

2. Forcefully brush the chains to get rid of any unwanted material with a hard nylon brush and clean diesel fuel.
3. Clean the chains by means of a paint brush soaked with clean diesel fuel and dry them with a compressed air jet.
4. Check carefully each chain for any signs of wear.
5. Grease the chains sparingly.

◀ 5.1.1 Lubricants & fuel - MI 50L→100 D D ST5 S1, page 108

4.12.2 REPLACE THE ENGINE OIL



Dispose of the drain oil in an ecological manner.

Put the machine on level ground, let the engine run at idle for a few minutes and then stop the engine.

1. Open the rear cover.
2. Clean the areas around the filler plug and oil filter.
3. Draining the oil

- 3.1. Remove the filler plug (1) to make sure that the oil is drained properly.

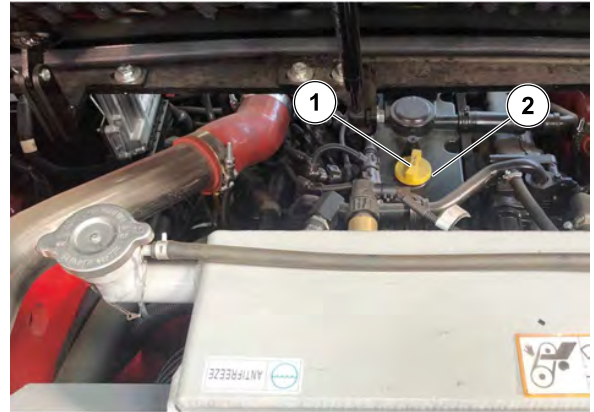

Figure 71: Filler plug & filler port - MI 50L→70 D D ST5 S1

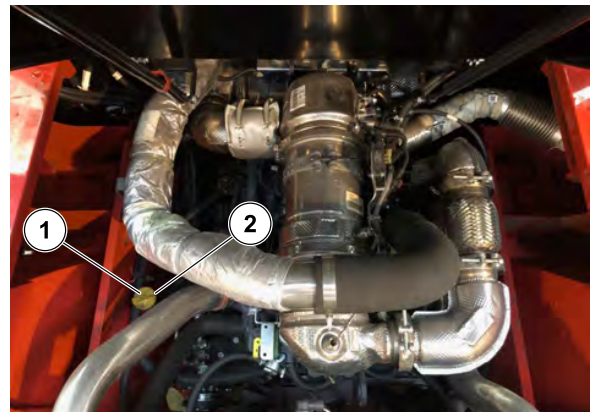

Figure 72: Filler plug & filler port - MI 80→100 D D ST5 S1

- 3.2. Put a container under drain plug (3) and unscrew the plug.



Figure 73: Drain plug & engine oil filter

4. Replacing the engine oil filter

- 4.1. Unscrew and discard the filter (4) together with its seal.
- 4.2. Clean the filter holder with a clean, lint-free cloth.
- 4.3. Lightly oil the seal before refitting the new filter on its bracket.
- 4.4. Tighten the oil filter (4).



15 to 17 N.m

5. Filling with oil

- 5.1. Refit and tighten the drain plug (3).



30 to 40 N.m

- 5.2. Fill up with oil through filler port (2).



For this operation, we recommend that you use a funnel fitted with a hose.

- 5.3. Wait a few minutes to let the oil to flow into the sump.
- 5.4. Start the engine and let it run for a few minutes.
- 5.5. Do a check for possible leaks from the drain plug and the oil filter.
- 5.6. Stop the engine; wait a few minutes.
- 5.7. Open the rear cover.
- 5.8. Do a check of the engine oil level.

◀ 4.4. Opening the rear cover - MI 50L → 70 D D ST5 S1, page 77

◀ 4.5. Opening the rear cover - MI 80 → 100 D D ST5 S1, page 78

◀ 4.10.4 Check the engine oil level, page 84

4.13. 1000 HOURS OF SERVICE OR 2 YEARS

4.13.1 CHECK THE SEAT BELT

⚠ DANGER

If the seat belt is defective (fixing, locking, cuts, tears, etc.), the machine must not be used.

Repair or replace the seat belt immediately.

1. Seat belt with two anchoring points



Check the following points:

- 1.1. Fixing of the anchoring points on the seat.
- 1.2. Cleanliness of the strap and the locking mechanism.
- 1.3. Triggering of the locking mechanism.
- 1.4. Condition of the strap (cuts and curled edges).
2. Reeled seat belt with two anchoring points
 - Check the points listed above before checking the following points:
 - 2.1. The correct winding of the belt.
 - 2.2. Condition of the reel guards.
 - 2.3. Roller locking mechanism when the strap is given a sharp tug.

4.13.2 GREASE THE SERVICE BRAKE PEDAL AXLE

⚠ WARNING

In the event of prolonged use in an extremely dusty or oxidizing atmosphere, reduce this interval to 500 hours of service or every year.

In case of technical faults, consult your dealer.

1. Remove the floor mat.
2. Unscrew the screws (1).

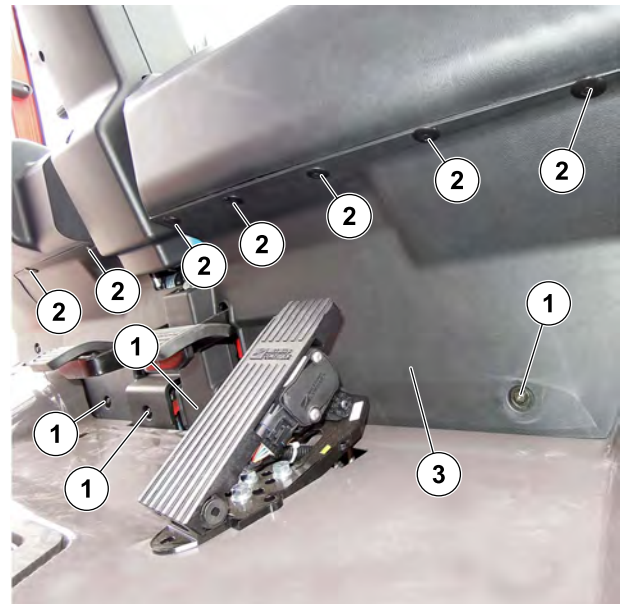

Figure 74: Service brake pedal axle

3. Remove the clips (2) in order to remove the casing (3).

- Clean and grease the grease fitting (4) located at the end of the brake pedal axle and remove unwanted grease.

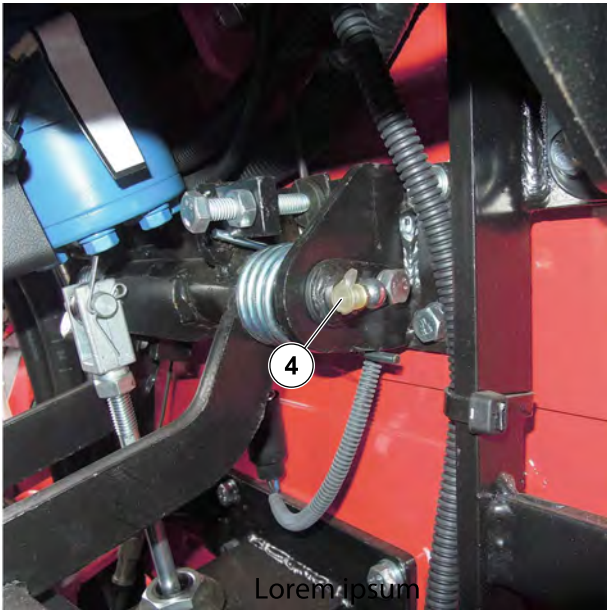

Figure 75: Service brake pedal axle grease fitting

4.13.3 REPLACE THE FUEL FILTER

- Power down the machine.
- Open the engine cover.
- Carefully clean the outside of the filter (1) and its holder to prevent dust from getting into the system.



Figure 76: Fuel filter

- Unscrew and discard the filter (1) together with its seal.

- Clean the inside of the filter (1) head using a brush soaked in clean diesel oil.
- Lubricate the seal of the new filter.
- Refit the new filter onto its support bracket, hand-tighten it only and lock it with a quarter-turn.
- Replace the fuel pre-filter.

◀ 3.2.3 Powering down the machine, page 61

◀ 4.3. Opening the engine cover, page 76

◀ 4.13.4 Replace the fuel pre-filter, page 97

4.13.4 REPLACE THE FUEL PRE-FILTER

- Carefully clean the outside of the pre-filter and its holder to prevent dust from getting into the system.
- Disconnect the wiring harness (1).

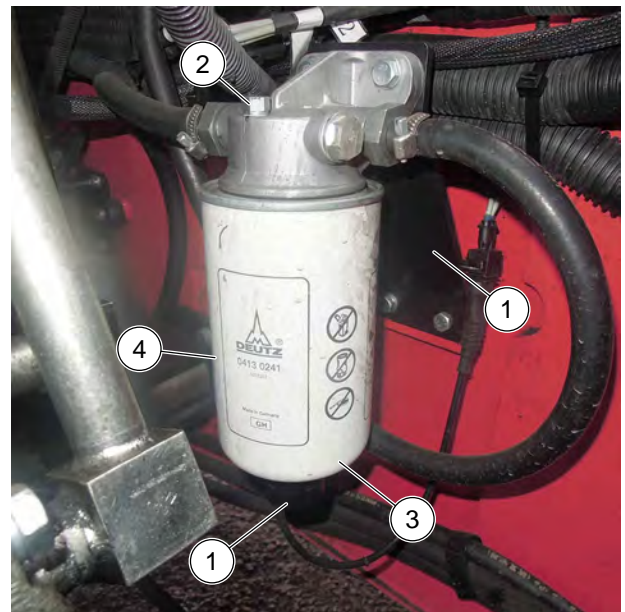

Figure 77: Fuel pre-filter

- Open bleed screw (2) to ensure proper emptying.
- Put a receptacle under the drain plug (3) and unscrew by two to three turns.
- Re-tighten bleed screw (2) once the pre-filter is emptied.
- Unscrew and discard the pre-filter (4) together with its seal.
- Clean the inside of the filter head using a brush immersed in clean diesel oil.
- Lubricate the seal of the new filter.
- Refit the new filter onto its support bracket, hand-tighten it only and lock it with a quarter-turn.
- Reconnect the wiring harness (1).

11. Turn on the machine's ignition and wait for the boost pump to stop to bleed the fuel supply system.

12. Start up the engine and check for leaks.

◀ 3.2.2 Powering up the machine, page 61

4.13.5 REPLACE THE DRY AIR FILTER CARTRIDGE

In very dusty atmospheres, the cartridge replacement frequency must be reduced to 250 hours.

However, there are pre-filtration elements; if necessary, contact your dealer.

⚠ WARNING

Replace the cartridge in a clean location with the engine stopped.

Never operate the machine with the air filter removed or damaged.

1. Open the engine cover.
2. Release the locks (1) and remove the cover (2) .

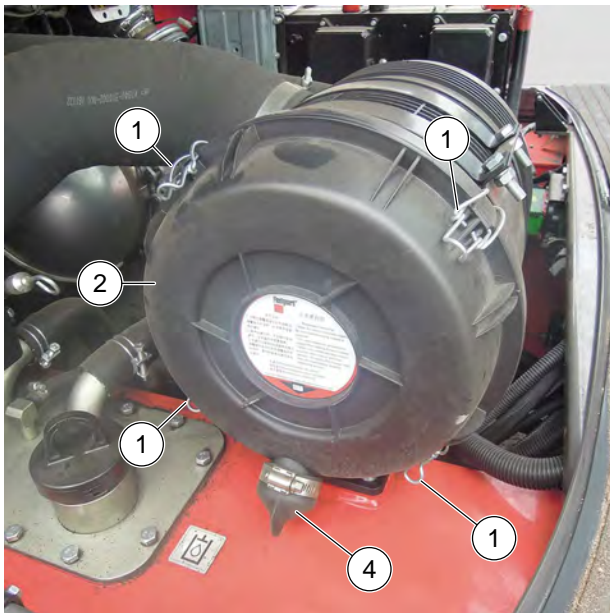

Figure 78: Dry air filter

3. Gently remove the cartridge (3) taking care to avoid spilling of the dust.



Figure 79: Dry air filter cartridge

4. Leave the safety cartridge in place.
5. Carefully clean the parts that follow with a clean, damp, and lint-free cloth:
 - 5.1. The inside of the filter and its cover and the inlet hose.
 - 5.2. The gasket surfaces of the filter and the cover.
6. Check the condition and attachment of the hoses between the air filter and the engine.
7. Check the condition and connection of the clogging indicator on the filter.
8. Check the condition of the new filter cartridge.
9. Introduce the cartridge into the filter axis, pressing on the edges and not the middle.
10. Refit the cover (2), with valve (4) directed downwards.

◀ 4.3. Opening the engine cover, page 76

4.13.6 REPLACE THE GEARBOX OIL

Put the machine on level ground with the engine stopped and the gear box oil still warm.

1. Open the engine cover.
2. Draining the gearbox oil

2.1. Remove gauge (1) to ensure proper emptying.



Figure 80: Gearbox oil gauge - MI 50 L→70 D D ST5 S1

3.1. Unscrew and discard the filter (3) together with its seal.



Figure 82: Gearbox oil filter

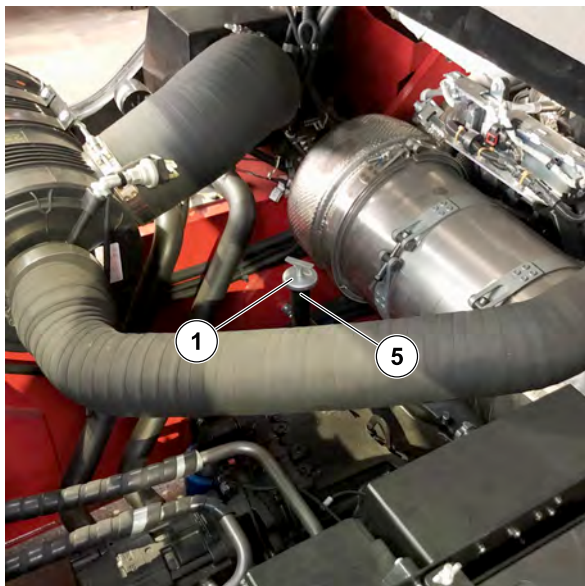

Figure 81: Gearbox oil gauge - MI 80→100 D D ST5 S1

3.2. Lubricate the seal of the new filter.
3.3. Refit the new filter onto its support bracket, hand-tighten it only and lock it with a quarter-turn.

4. Cleaning the metal oil Filter

4.1. Unscrew the filter (4).



Figure 83: Metallic oil filter

2.2. Place a container under drain plug (2) and unscrew the plug.



Dispose of the drain oil in an ecological manner.

3. Replacing the oil filter

4.2. Clean the filter with a compressed air jet.

4.3. Refit the unit.

5. Filling with Oil

5.1. Fill up with oil through filler port (5).

- 5.2. Wait a few minutes to let the oil to flow into the sump.
- 5.3. Reinsert dipstick (1) and remove it again.
- 5.4. Do a check of the correct level between the two marks on the dipstick.
- 5.5. Start the engine and let it run for a few minutes.
- 5.6. Do a check for possible leaks.
- 5.7. Stop the engine, wait a few minutes and do a check of the level on the dipstick.
- 5.8. Top up the level if necessary.

◀ 4.3. *Opening the engine cover*, page 76

◀ 5.1.1 *Lubricants & fuel - MI 50L→100 D D ST5 S1*, page 108

4.13.7 REPLACE THE HYDRAULIC OIL

Put the machine on level ground with the engine stopped and the gear box oil still warm.

NOTICE

It is sometimes necessary to bleed the circuits at the pump inlets when an air bubble has formed during draining. In this case, refer to your dealer.

1. Open the engine cover.

2. Remove the air intake housing (1) to gain access to the inspection cover.



Dispose of the drain oil in an ecological manner.

Before carrying out any work, thoroughly clean the area surrounding the drain plug and the suction cover on the hydraulic tank.

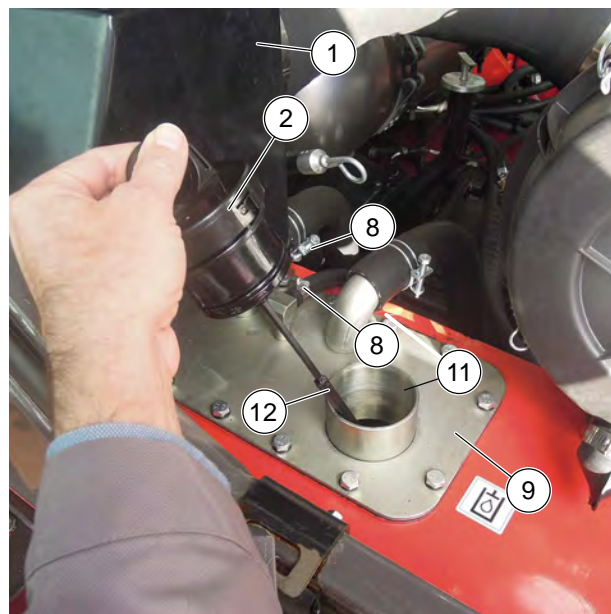

Figure 84: Hydraulic oil replacement

3. Draining the oil

3.1. Remove the filler plug (2) to make sure that the oil is drained properly.

3.2. Put a container under drain plug (3) and unscrew the plug.

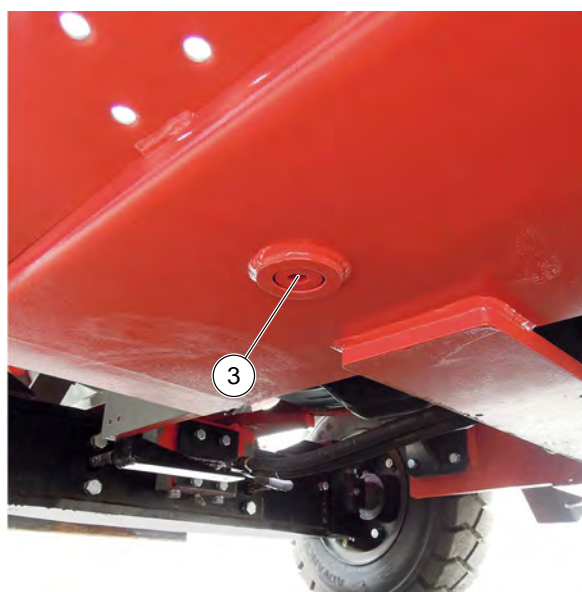

Figure 85: Hydraulic oil drain plug

4. Replacing the oil filter

- 4.1. Carefully clean the outside of the filter and its holder to prevent dust from getting into the system.
- 4.2. Unscrew and discard the filter (4) together with its seal.



Figure 86: Hydraulic oil filter location

- 4.3. Clean the inside of the filter head.
- 4.4. Lubricate the seal of the new filter.
- 4.5. Refit the new filter onto its support bracket, hand-tighten it only and lock it with a quarter-turn.

5. Filter plug cleaning

- 5.1. Remove the cover (5) of filler plug (2) by twisting through a quarter turn.



Figure 87: Filter plug cleaning

- 5.2. Remove and clean the filter (6).
- 5.3. Clean the filter mounting (7).
- 5.4. Refit the unit.

6. Cleaning of strainers

- 6.1. Disconnect the hoses (8).
- 6.2. Remove the access panel (9).
- 6.3. Unscrew the suction strainers (10) in the bottom of the tank.
- 6.4. Clean the strainers with a compressed air jet.
- 6.5. Check the condition of the strainers and replace if necessary.
- 6.6. Refit the unit.

7. Filling with oil

- 7.1. Clean and refit the drain plug (3).

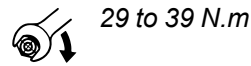

- 7.2. Fill up with oil through filler port (11).
- 7.3. Check the oil level on dipstick (12).
- 7.4. Check for possible leaks at the drain plug.

8. Hydraulic circuit decontamination

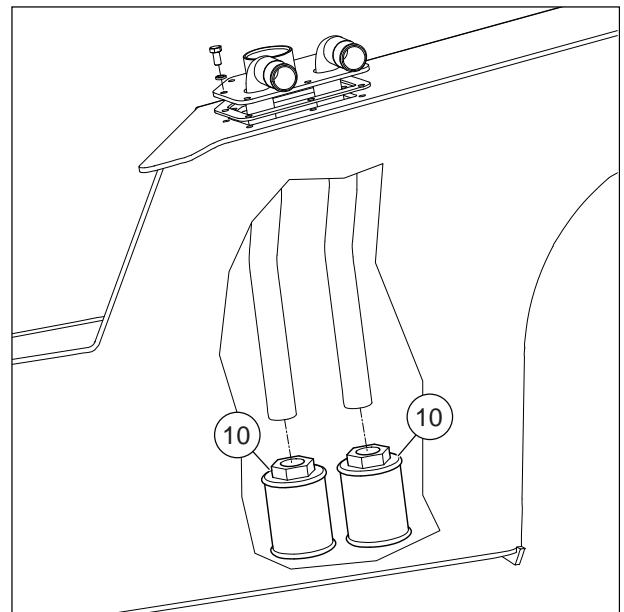

Figure 88: Hydraulic circuit decontamination

- 8.1. Let the engine run (accelerator pedal at mid position) for 5 minutes without using any accessories on the machine, then for 5 more minutes while using all the hydraulic movements (except the steering system and the service brakes).

8.2. Accelerate the engine at full speed for 1 minute, then activate the steering system and the service brakes.

8.3. This operation allows the circuit to be decontaminated by the hydraulic oil filter.

◀ 4.3. *Opening the engine cover*, page 76

◀ 4.11.8 *Check the hydraulic oil level*, page 88

◀ 5.1.1 *Lubricants & fuel - MI 50L→100 D D ST5 S1*, page 108

4.14. 2000 HOURS OF SERVICE OR 4 YEARS

4.14.1 CHECK THE WHEEL NUT TIGHTENING TORQUES

1. Check the condition of the tires to detect cuts, blisters, wear, etc.
2. Check the tightening torque of the wheel nuts with a torque wrench.



Front wheels: 441 to 588 N.m



Rear wheels: 441 to 588 N.m

4.14.2 CLEAN THE FUEL TANK

⚠ DANGER

Do not smoke or approach with a flame during this operation.

Never attempt to carry out welding or any other operation by yourself, as this could cause an explosion or a fire.

1. Put the machine on level ground with the engine stopped.
2. Check any possible leaks in the fuel system and tank.
3. In the event of a leak, never carry out any welding or other operation yourself; speak to your dealer.

4. Remove the filler plug (1) to make sure that the fuel is drained properly.



Figure 89: Filler plug location

5. Put a container under drain plug (2) and unscrew the plug.



Figure 90: Drain plug location

6. Rinse out with 10 litres of clean diesel fuel through filler port (3).
7. Refit and tighten the drain plug (2).



29 to 39 N.m

8. Fill the fuel tank with clean, filtered diesel fuel.

9. Refit the filler plug (1).
10. If necessary, bleed the fuel supply system.

◀ 5.1.1 Lubricants & fuel - MI 50L→100 D D ST5 S1, page 108

4.14.3 REPLACE THE COOLANT

These operations are to be carried out as necessary or every two years at the beginning of winter.

NOTICE

The engine does not contain any corrosion resistor and must be filled during the whole year with a mixture containing 25 % of ethylene glycol-based antifreeze.

1. Put the machine on level ground with the engine stopped and cold.
2. Open the rear cover.
3. Draining the coolant
 - 3.1. Remove the filler plug (1) to make sure that the oil is drained properly.



Figure 91: Filler plug location

- 3.2. Put a container under the lower radiator hose (4) and remove it.

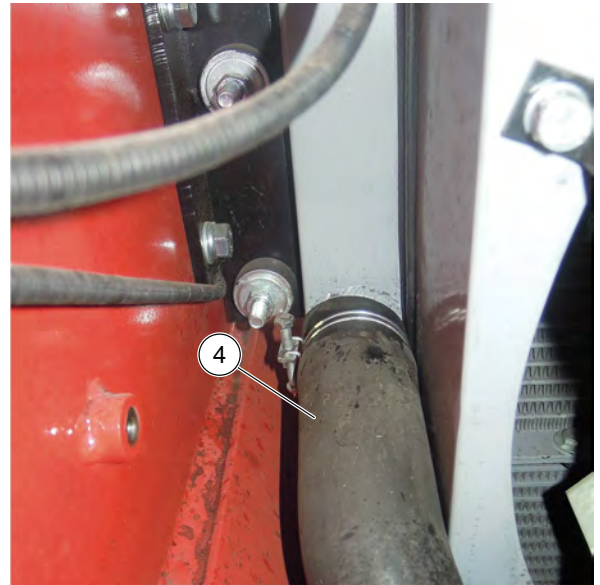

Figure 92: Lower radiator hose location

- 3.3. Let the cooling circuit drain entirely while making sure that the ports do not get clogged.
- 3.4. Check the condition of the hoses as well as the fasteners and change them if necessary.
- 3.5. Clean the circuit with clean water and use a cleaning agent if necessary.
4. Filling with coolant
 - 4.1. Refit the radiator hose (4).
 - 4.2. Slowly fill the system with the coolant through the filler port (2).
 - 4.3. Run the engine at idle for a few minutes.
 - 4.4. Check for any possible leaks.
 - 4.5. Check the coolant level (up to 15 mm below the filler port opening (2)).
 - 4.6. Lubricate slightly the filler neck to facilitate the setting and the removal of the radiator cap.
 - 4.7. Put back the radiator filler cap (1).

◀ 4.4. Opening the rear cover - MI 50L→70 D D ST5 S1, page 77

◀ 4.5. Opening the rear cover - MI 80→100 D D ST5 S1, page 78

◀ 5.1.1 Lubricants & fuel - MI 50L→100 D D ST5 S1, page 108

4.14.4 REPLACE THE DRY AIR FILTER SAFETY CARTRIDGE

NOTICE

The safety cartridge replacement frequency is given for information only.

It must be changed every second time the dry air filter cartridge is changed.

1. Open the engine cover
2. Disassemble the dry air filter cartridge.
3. Carefully remove the dry air filter safety cartridge (1), taking care to avoid spilling the dust.



Figure 93: Dry air filter safety cartridge

4. Clean the gasket surface of the safety cartridge with a clean, damp, lint-free cloth.
5. Check the condition of the new safety cartridge.
6. Introduce the safety cartridge into the filter axis, pressing on the edges and not the middle.
7. Reassembly the dry air filter cartridge.

◀ 4.3. Opening the engine cover, page 76

4.14.5 REPLACE THE FRONT AXLE DIFFERENTIAL OIL

Put the machine on level ground with the engine stopped and the still warm differential oil.

1. Raise the mast to gain access to the plugs.

2. Put a container under drain plug (1) and unscrew the plug.



Figure 94: Drain plug location

3. Remove level plug (2) and fill plug (3) to make sure that the oil is drained properly.

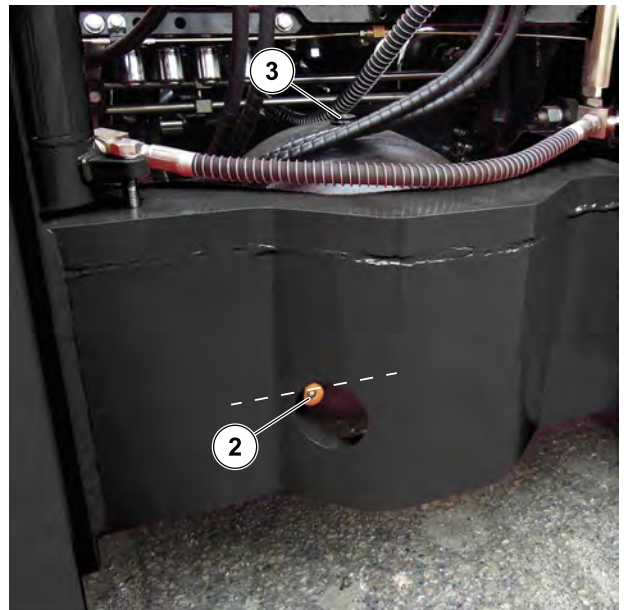

Figure 95: Level plug and fill plug location

4. Refit and tighten the drain plug (1).



34 to 49 N.m

5. Fill up with oil through filler port (3).
6. The level is correct when the oil level is flush with the edge of opening (2).

7. Check for any possible leaks at the drain plug.
8. Refit and tighten the level plug (2) and the filling plug (3).

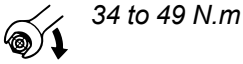

5.1.1 Lubricants & fuel - MI 50L→100 D D ST5 S1, page 108

4.15. OCCASIONAL MAINTENANCE

4.15.1 REPLACE WHEEL

⚠ WARNING

In the event of a wheel being changed on the public highway, secure the lift truck vicinity

1. Stop the lift truck, if possible on firm, level ground.
2. Shut down the lift truck.
3. Switch on the warning lights (option).
4. Immobilise the lift truck in both directions on the axle opposite to the wheel to be changed.
5. Unlock the nuts of the wheel to be changed.
6. Rear wheel

 For this operation, we advise you to use the hydraulic jack (MANITOU Part no. 505507).

- 6.1. Place the jack under the counterweight. It must be situated in the middle and under the flat part of the counterweight.



- 6.2. Lift the wheel until it comes off the ground and put in place the safety block under the axle.
- 6.3. Completely unscrew the wheel nuts and remove them.
- 6.4. Free the wheel by reciprocating movements and roll it to the side.
- 6.5. Slip the new wheel on the wheel hub.

- 6.6. Hand-tighten the nuts, grease them if necessary.
 - 6.7. Remove the security block and lower the lift truck with the jack.
 - 6.8. Tighten the wheel nuts using a torque wrench for the tightening torque.
7. Front wheel
 - 7.1. Lift the carriage and tilt the mast backwards.
 - 7.2. Immobilise under the foot of the mast on the side where the wheel is being changed.
 - 7.3. Tilt the mast forwards to lift the wheel.
 - 7.4. Place wedges under the chassis as near as possible to the wheel.
 - 7.5. Completely unscrew the wheel nuts and remove them.
 - 7.6. Free the wheel by reciprocating movements and roll it to the side.
 - 7.7. Slip the new wheel on the wheel hub.
 - 7.8. Hand-tighten the nuts, grease them if necessary.
 - 7.9. Remove the wedges under the axle and lower the lift truck.
 - 7.10. Tighten the wheel nuts using a torque wrench for the tightening torque.

4.15.2 REPLACE BATTERY

⚠ WARNING

Batteries hazards

Always replace the battery in well-ventilated areas sheltered from sun and rain.

Make sure that the positive terminals can not come into contact with the negative terminals.

Make sure that the positive terminals can not come into contact with metallic parts of the machine.

Do not allow flames or sparks and do not smoke near the battery during maintenance.

Always wear protective clothing, gloves and safety eyewear or face shield during maintenance.

In the event of electrolyte being spilled onto the skin or splashed in the eyes, rinse thoroughly with cold water for 15 minutes and call a healthcare professional.

Replacing a battery

1. Open the engine cover.
2. Identify the faulty battery.
3. Unscrew the nut (1) to release the battery retaining strap (2).

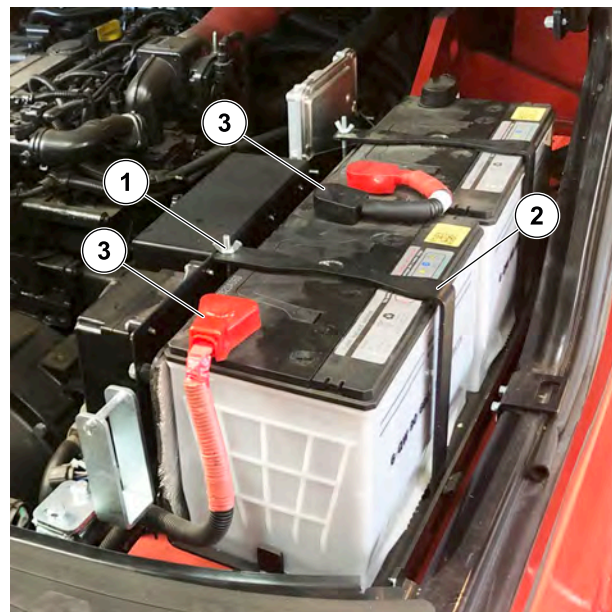

Figure 96: Battery replacement

4. Disconnect the battery terminals (3).
5. Remove the faulty battery.
6. Place a new battery of the same type as the one used for the lift truck, observing the (+) and (-) polarity.
7. Refit the retaining strap (2).

Breakdown repair using a back-up battery

1. Open the engine cover.
2. Bring a back-up battery of the same type as the one used for the machine, together with battery cables.
3. Connect the back-up battery with the battery cables, observing the (-) and (+) polarity.
4. Start the machine and remove the cables as soon as the engine is running.

◀ 4.3. *Opening the engine cover*, page 76

4.16. OCCASIONAL OPERATION

4.16.1 WINCHING/TOWING THE MACHINE

NOTICE

Risk of excessive machine wear

While towing, steering and hydraulic assistance are disabled.

Do not tow the machine at more than 25 km/h.

Operate the steering wheel and pedal slowly avoiding sudden or jerky movements.

1. Place the gear selector in neutral position.
2. Release the parking brake.
3. Switch on the hazard warning lights.
4. Since there will be no steering or braking hydraulic assistance, operate the steering wheel and pedal slowly avoiding sudden or jerky movements.

4.16.2 LIFTING THE MACHINE - MI 50L → 100 D D ST5 S1

1. Take into account the position of the machine center of gravity when lifting.

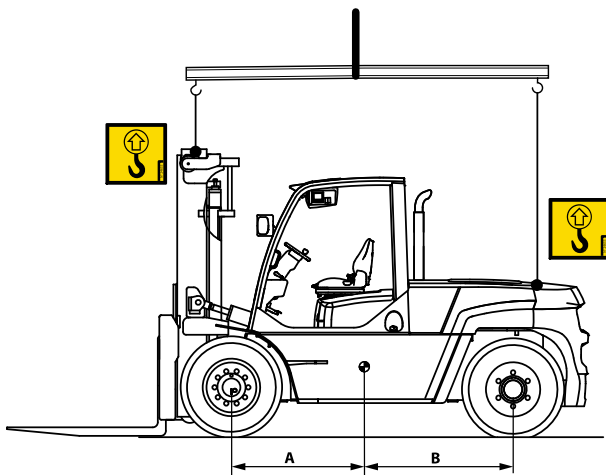

Figure 97: Fastening points

Machine	A (mm)	B (mm)
MI 50L D D ST5 S1	1170	1130
MI 60 D D ST5 S1	1269	1031
MI 70 D D ST5 S1	1363	937
MI 80 D D ST5 S1		
MI 100 D D ST5 S1		

2. Place the hooks in the fastening points provided and around the uprights of the guard.



Figure 98: Mast fastening points



Figure 99: Counterweight fastening points

5. REFERENCES & ATTACHMENTS

5.1. REFERENCES

5.1.1 LUBRICANTS & FUEL - MI 50L→100 D D ST5 S1

Recommended lubricants and fluids

NOTICE

Use the recommended lubricants and fuel:

For topping up, oils may not be miscible.

For oil changes, MANITOU oils are perfectly appropriate.

Diagnostic analysis of oils and Diesel Exhaust Fluid "DEF"

If a service or maintenance contract has been set up with the dealer, a diagnostic analysis of engine, transmission and axle oils may be requested depending on the rate of use.

If the machine is not used for up to 4 months, check the "DEF" quality.



The Diesel Exhaust Fluid quality can be measured using a refractometer (MANITOU Part number 959709).

Beyond 4 months, replace the "DEF".

Recommended fuel specification:

Use a high-quality fuel to obtain optimal performance of the engine.

- Type of diesel fuel EN590
- Type of diesel fuel ASTM D975.

Recommended Diesel Exhaust Fluid "DEF" specification:

- The Diesel Exhaust Fluid must comply with standard ISO 22241-1 with a urea concentration of 32.5%

Machine oils and lubricants

Table 82. Engine

Description	Capacity	Recommendation	Temperature range
Engine	9 Litres	MANITOU Oil API CJ4	
Cooling circuit	23 Litres	Cooling fluid (protection - 25°)	-25 °C / +55 °C
		Cooling fluid (protection - 35°)	-35 °C / +55 °C
Fuel tank MI 50L → 70 D D ST5	110 Litres	Diesel fuel	-20 °C / +55 °C
Fuel tank MI 80 → 100 D D ST5	120 Litres		

Table 83. Mast

Description	Recommendation	Temperature range
Mast lifting chains	MANITOU Lubricant Chain special (aerosol)	-20 °C / +55 °C
Greasing of the mast	MANITOU Grease BLACK multi- purpose	-20 °C / +55 °C

Table 84. Hydraulics

Description	Capacity	Recommendation	Temperature range
Hydraulic oil tank	110 Litres	MANITOU Oil Hydraulic ISO VG 32	-25 °C / +20 °C

Table 85. Transmission

Description	Capacity	Recommendation	Temperature range
Transmission	25 Litres	MANITOU Oil Engine Premium 15W40	-25 °C / +50 °C
Differential / axle MI 50L → 70 D D ST5	6.5 Litres	MANITOU Oil TRANS MECA	-45 °C / +55 °C
Differential / axle MI 80 → 100 D D ST5	15 Litres		

Table 86. Rear axle

Description	Recommendation	Temperature range
Swivel pins	MANITOU Grease BLUE multi-purpose	-25 °C / +55 °C
Steering connecting rod		
Rear axle oscillation		
Rear wheel bearings		

Table 87. Cab

Description	Recommendation	Temperature range
Cab door	MANITOU Grease BLUE multi-purpose	-25 °C / +55 °C
Windscreen washer tank	Windscreen washer liquid	-45 °C / +55 °C

5.1.2 FILTER ELEMENTS & BELTS - MI 50L→100 D D ST5 S1

Table 88. Periodicities of filters and belts

Description	① 500H	② 1000H	③ 2000H
Air filter cartridge		•	
Safety air filter cartridge			•
Fuel filter		•	
Fuel pre-filter		•	
Engine oil filter	•		
Main circuit strainer		•	
Fan belt			•
Alternator belt			•
Hydraulic filter		•	
Hydraulic return oil filter cartridge		•	

5.1.3 FUSES & RELAYS - MI 50L→100 D D ST5 S1

To access fuses and relays, [4.3. Opening the engine cover, page 76](#).

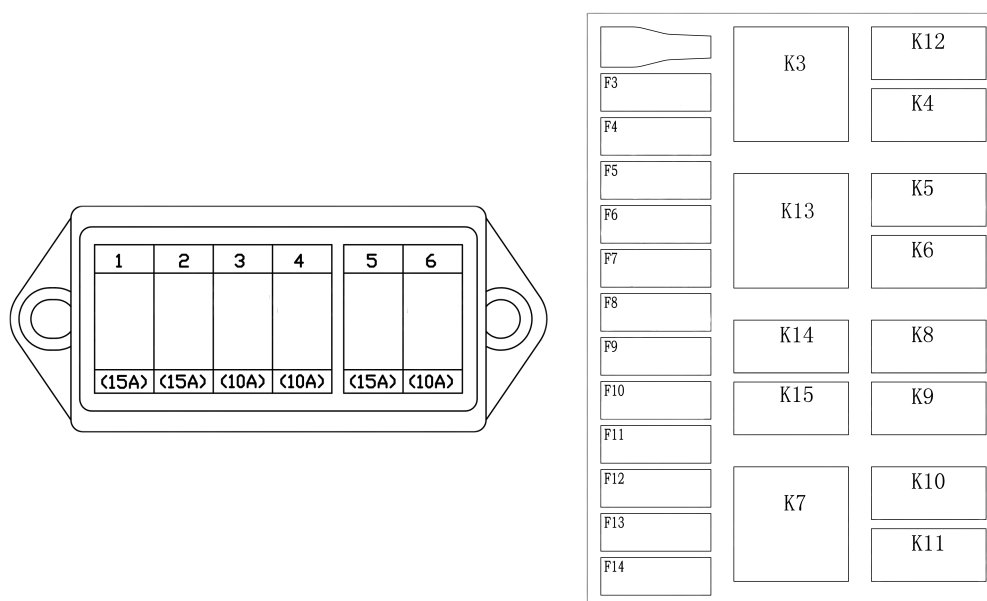

Figure 100: Fuses & relays location

Table 89. List of fuses - MI 50L→100 D D ST5 S1

Fuse	Rating	Description
F3	10A	Engine preheat
F4	30A	Starter
F5	10A	Engine fault code
F6	7.5A	Reversing shift

Fuse	Rating	Description
F7	5A	Gearbox control unit
F8	10A	Dashboard
F9	10A	Rear working light / Rotating beacon light
F10	10A	Stop lights / Indicator lights

Fuse	Rating	Description
F11	10A	Horn
F12	15A	Control unit 1 "SCR"
F13	5A	Control unit 2 "SCR"
F14	30A	Control unit 3 "SCR"
1	15A	Front windscreen wiper
2	15A	Rear windscreen wiper
3	10A	Free
4	10A	Free
5	15A	Free
6	10A	Free

Table 90. List of relays - MI 50L→100 D D ST5 S1

Relay	Description
K3	Starting
K4	Middle
K5	Pump
K6	Reverse gear
K7	Engine preheat
K8	Regeneration "SCR" 1
K9	Regeneration "SCR" 2
K10	Regeneration "SCR" 3
K11	Heat model
K12	Mast
K13	Rotating beacon light
K14	Rear working light
K15	Armrest switch

↳ 4.3. Opening the engine cover, page 76

5.2. ATTACHMENT SPECIFICATIONS

5.2.1 INTRODUCTION

Your lift truck must be used with interchangeable equipment. These items are called: ATTACHMENTS. A wide range of attachments, specially designed and perfectly suitable for your lift truck is available and guaranteed by MANITOU.

NOTICE

Only attachments approved by MANITOU are to be used on our lift trucks. The manufacturer's liability will be denied in case of modification or of attachment adaptation carried out without his knowing it.

The attachments are delivered with a load chart concerning your lift truck. The operator's manual and the load chart should be kept in the places provided in the lift truck. For standard attachments, their use is governed by the instructions contained on this notice.

⚠ WARNING

Maximum loads are defined by the capacity of a lift truck taking account of the attachment's mass and centre of gravity. In the event of the attachment having less capacity than the lift truck, never exceed this limit. All attachments with a suspended load (winch, crane jib, crane jib with winch, hook, etc.) MUST be used with a lift truck equipped with a hydraulic movement cut-out device. In this case, the movement cut-out must be switched on and the transverse attitude perfectly horizontal.

Some particular uses require the adaptation of the attachment which is not provided in the price-listed options. Optional solutions exist, consult your dealer.

5.2.2 TECHNICAL SPECIFICATIONS OF ATTACHMENTS

Standardized forks for MI 50L D/60 D ST5 S1

Table 91. Standardized forks specifications for MI MI 50L D/60 D ST5 S1

PART NUMBER	52522264	52522269	52522270	52525433	
Section	150 X 60 X 1220 mm	150 X 60 X 1520 mm	150 X 50 X 2000 mm	150 X 50 X 2440 mm	
Weight	kg	kg	kg	kg	

Standardized forks for MI 70 D ST5 S1

Table 92. Standardized forks specifications for MI MI 70 D ST5 S1

PART NUMBER	52522432	52522434	52522435	52525436	
Section	150 X 65 X 1220 mm	150 X 65 X 1520 mm	150 X 65 X 2000 mm	150 X 65 X 2440 mm	
Weight	kg	kg	kg	kg	

Standardized forks for MI 80 D ST5 S1

Table 93. Standardized forks specifications for MI MI 80 D ST5 S1

PART NUMBER	52522267	52522271	52522272	
Section	160 X 75 X 1520 mm	160 X 75 X 2000 mm	160 X 75 X 2440 mm	
Weight	kg	kg	kg	

Standardized forks for MI 100 D ST5 S1

Table 94. Standardized forks specifications for MI MI 100 D ST5 S1

PART NUMBER	52522268	52522273	52522274	
Section	160 X 80 X 1520 mm	160 X 80 X 2000 mm	160 X 80 X 2440 mm	
Weight	kg	kg	kg	

Fork protector

Table 95. Fork protector specifications

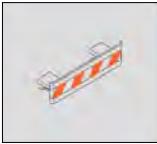
PART NUMBER	227801	

For Support and Service, Contact Your Dealer

